

NutroniK8000
Recorder
Model KSR110/210/310
Operator's Manual

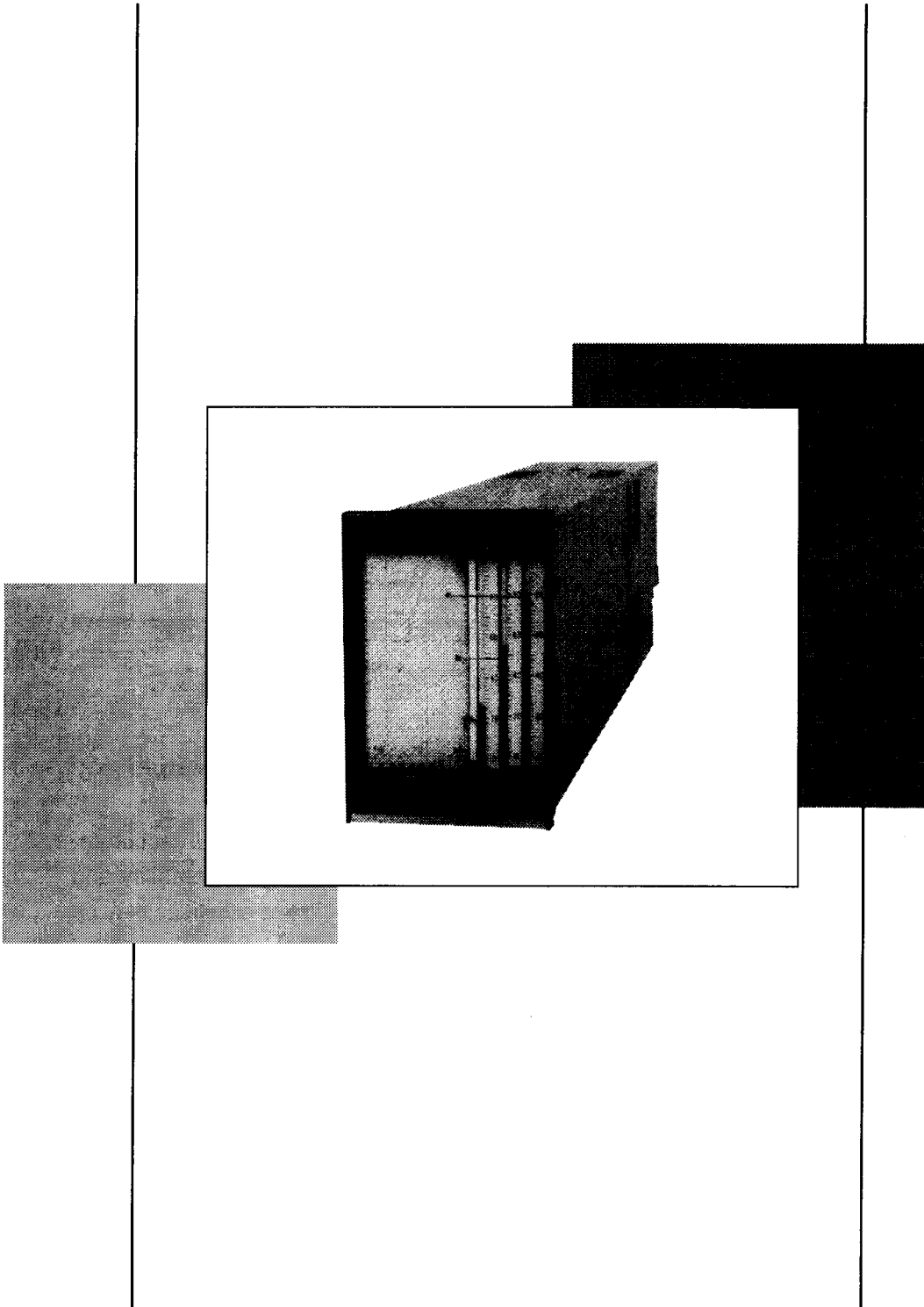

Copyright, Notices and Trademarks

Printed in Japan - © Copyright 1998 by Yamatake Corporation

While this information is presented in good faith and believed to be accurate, Yamatake Corporation disclaims the implied warranties of merchantability and fitness for a particular purpose and makes no express warranties except as may be stated in its written agreement with and for its customer.

In no event is Yamatake Corporation liable to anyone for any indirect, special or consequential damages. The information and specifications in this document are subject to change without notice.

Table of Contents

Section 1. General	1
1.1 Features	1
1.2 Construction	2
Section 2. Specifications	5
2.1 Specifications	5
2.2 Model Number Table	7
Section 3. Operating Principle	9
Section 4. Installation	11
4.1 Installation Method	11
4.2 External connection	11
Section 5. Operation Method	15
5.1 To Pull Out Chassis from Case	15
5.2 Chart Paper Replacement	18
5.3 Ink Injection	22
5.4 Installing the Fiber Tip	24
5.5 Installing the Pen Cartridge	26
5.6 Selecting Chart Drive Speed	27
Section 6. Adjustment and Calibration	29
6.1 Preparation	29
6.2 Adjustment and Calibration	30
6.2.1 Servo Amplifier	30
6.2.2 Internal Monitor Switches	31
Section 7. Maintenance	33
7.1 Routine Maintenance	33

7.2 Replacement of Parts	33
7.2.1 Bezel and Door	33
7.2.2 Chart Drive Mechanism	33
7.2.3 Drive Cable	34
7.2.4 Pen assembly	36
7.2.5 Tape Assembly	37
7.2.6 Chart Motor Assembly	37
7.2.7 Monitor Switch	38
7.2.8 Servo Amplifier PC Board.....	39
7.2.9 Servo Unit.....	39
7.2.10 Pulse Motor	39
7.2.11 Potentiometer	40
7.2.12 Chart Drive PC Board	40
7.2.13 Main Connector Board.....	41
7.2.14 Life Expectancy of Components	41
7.3 Reference Drawings	43

Section 1. General

1.1 Features

The KSR1/KSR2/KSR3 Recorder accepts a 1 to 5V DC input signal and record it on a 100 mm wide recording chart with a cartridge pen. (The recorder is available either as a 1 pen type or 2 pen, or 3 pen type.)

As options, monitor switches (with alarm indicators) is available.

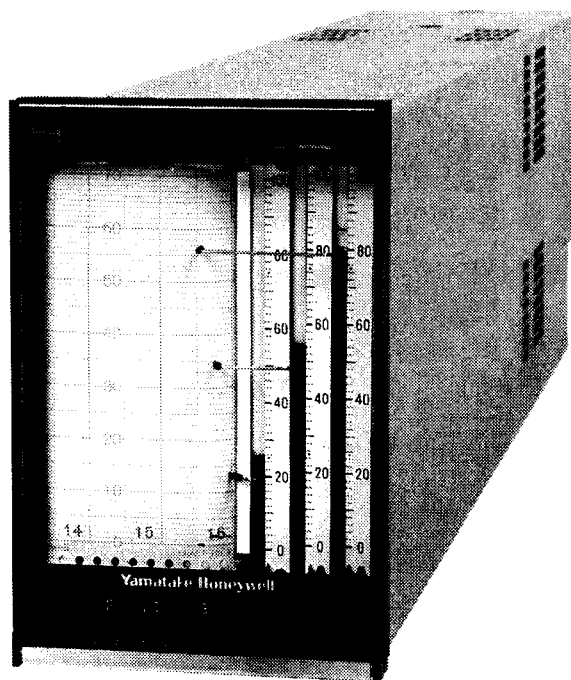

Figure 1-1. External of the Recorder

1.2 Construction

The major components of the recorder are as follows:

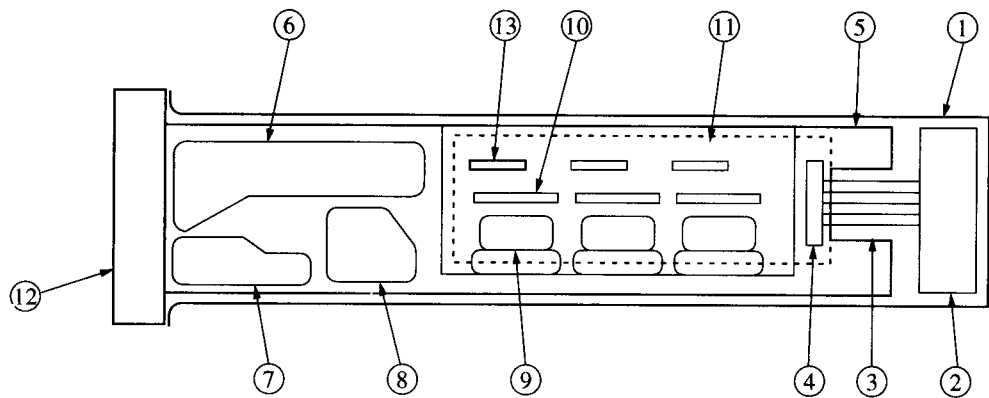
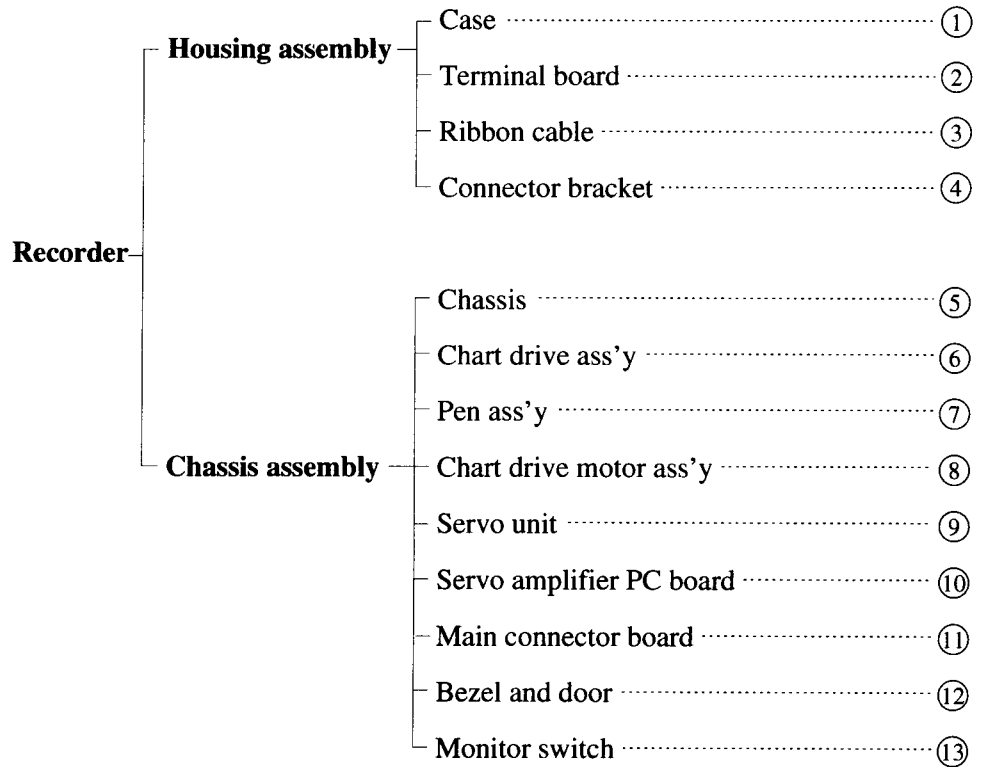

Figure 1-2. Top View of Components Layout

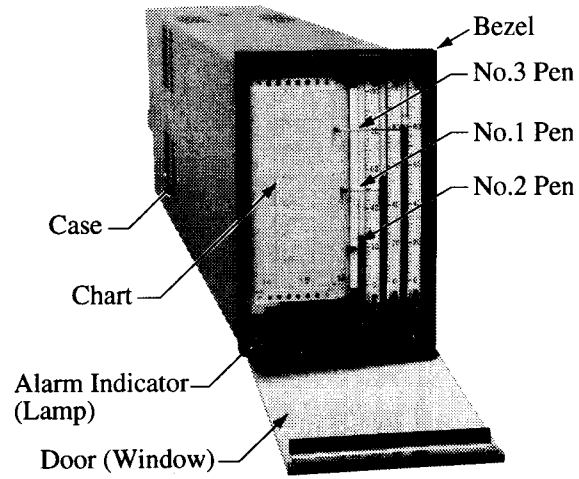

Figure 1-3. Front View (with door open)

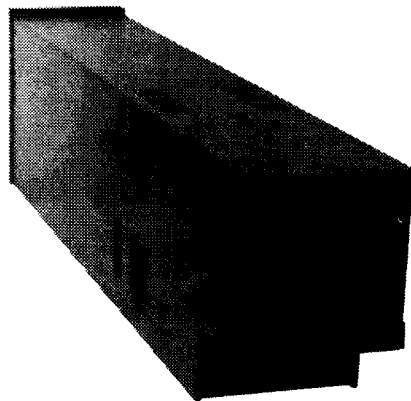

Figure 1-4. Rear View

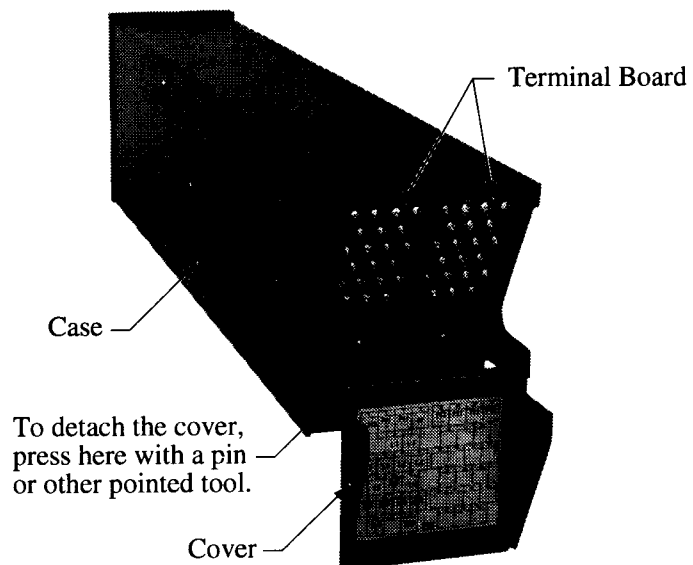

Figure 1-5. Terminal Board and Cover

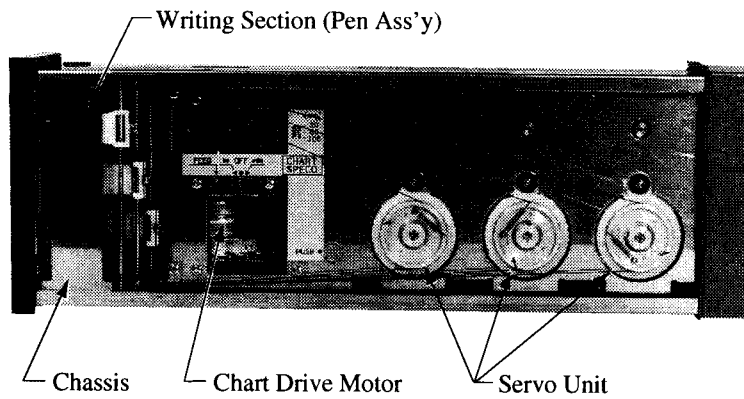

Figure 1-6. Right-hand Side of Chassis (as latch No. 3 engaged)

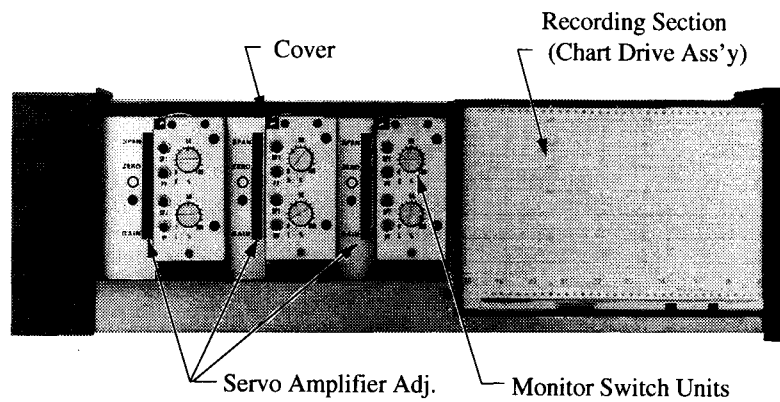

Figure 1-7. Left-hand Side of Chassis (as latch No. 3 engaged)

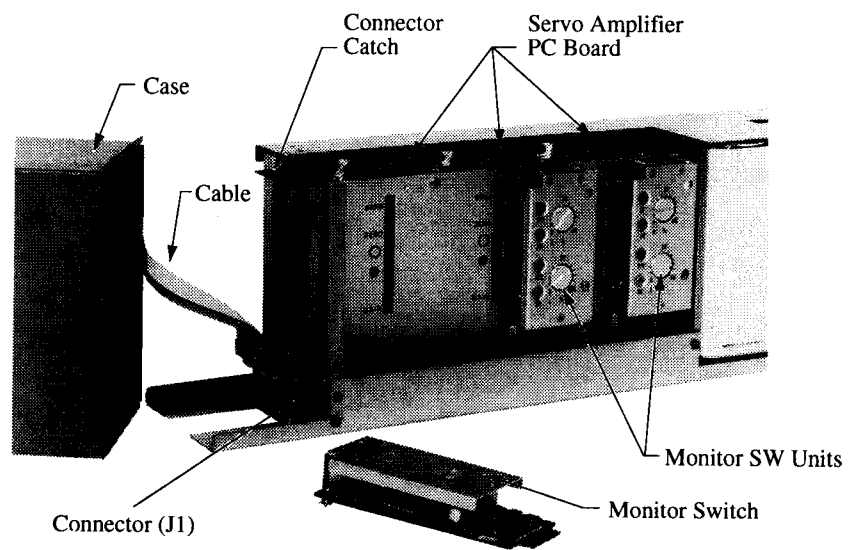

Figure 1-8. Left-hand Side of Chassis (with chassis pulled out and cover removed)

Section 2. Specifications

2.1 Specifications

■ Standard Specifications

Input signal	: 1 to 5V DC
Input bias current	: -1 μ A or less
No. of recording points	: 1 point, 2 points, or 3 points
Scale width	: 100 mm
Pen speed	: 6.0 \pm 1.5 sec/FS
Recording chart paper	
Type of chart	: Strip chart, rolled type
Chart paper width	: 115 mm
Effective recording width	: 100 mm
Chart drive speeds	: 20, 60, 100 mm per hour or minute (six speeds, semi-fixed)
Chart paper length	: 16 meters (to serve one month width 20 mm/hour)
Recording ink	: Fiber-tip pen (disposable type)
Color coding	: Red (#1 PV), blue (#2 PV), green (#3 PV)
Indicating accuracy	: \pm 0.5% FS
Power supply voltage	: 24V DC -10% and +15%
Power consumption (current)	: 1 pen type: 250 mA DC 2 pen type: 370 mA DC 3 pen type: 490 mA DC
Ambient temperature	: 0°C to +50°C (Recommended range of use is +10°C to +40°C)
Ambient humidity	: 10 to 90% RH
Installation	: Indoor panel, flush mount. Horizontal attitude (with rear side down by 60° maximum)
Finish	
Case	: Dark beige (Munsell 10YR4.7/0.5)
Bezel	: Black (Munsell N1.2)
Supply voltage regulation	: \pm 0.3% FS for supply voltage change within a range of 24V DC -10% and +15%
Ambient temperature regulation	: \pm 3% FS for temperature change within a range of 25°C \pm 20°C
Weight	: 8 kg

■ **Selective Items**

Chart motor ON/OFF control contacts: DC 30V, 0.1A

■ **Optional Items**

Alarm indicators

Number of indicated points : 6
ALARM HIGH ; 3 points (red LED)
ALARM LOW ; 3 points (red LED)
Input signal : Dry contact or transistor open collector
Current consumption : 12 mA maximum/lamp, (24V DC)

Internal monitor switch

Number of monitored points : 1 or 2 per input (high or low limit, or high and low limits)
Setting range : 0 to 100%
Setting accuracy : $\pm 5\%$ FS
Type of output signal : Transmitter open collector contact signal
Contact rating : 30V DC, 0.1A max., (resistance load)
Current consumption : 20 mA max. (24V DC)

Current input (Y46) : 4 to 20 mA DC
Y46A ; 1 point input
Y46B ; 2 points input,
Y46C ; 3 points input
input resistance 250 Ω

2.2 Model Number Table

Basic model no.	Selectable item		Options			Description	
	Power supply	Chart motor contacts	Monitor (PV1)	Monitor (PV2)	Monitor (PV3)		
KSR						Recorder	
	110					1-pen recorder	
	210					2-pen recorder	
	310					3-pen recorder	
		-0				DC 24V	
			0			With chart motor ON/OFF-control contacts	
			1			Without chart motor ON/OFF-control contacts	
				-0		Without lamp unit	
				-1		Lamp unit	
				-2		1-point monitor (With lamp unit)	
				-3		2-point monitor (With lamp unit)	
					0	Without lamp unit	
					1	Lamp unit	
					2	1-point monitor (With lamp unit)	
					3	2-point monitor (With lamp unit)	
						0	Without lamp unit
						1	Lamp unit
						2	1-point monitor (With lamp unit)
						3	2-point monitor (With lamp unit)

Notes : When ordering "Y" semi-standard options, please write as:

KSR110Y-01-000 (Y□)

Y46A; 4 to 20mA DC Input (For 1 Pt.)

Y46B; 4 to 20mA DC Input (For 2 Pts.)

Y46C; 4 to 20mA DC Input (For 3 Pts.)

MEMO

Section 3. Operating Principle

The input buffer is a differential amplifier with high input impedance and high common mode rejection ratio (CMRR). It has a filter (adjustable) to eliminate AC noise of the signal line and provides a stabilized 1 to 5V DC signal. This signal is compared with the voltage signal received from the feedback potentiometer. The two signals are null-balanced by the functions of the servo amplifier and pulse motor. The pulse motor is linked to the pen mechanism for ribbon display and pen recording of the signal.

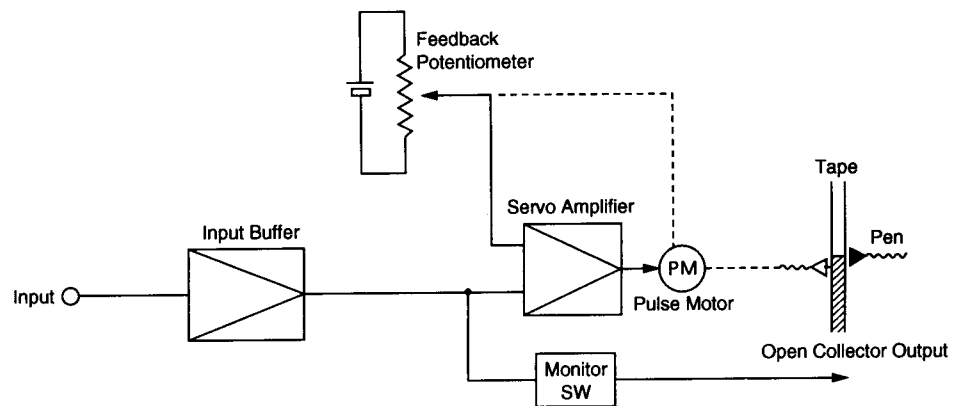

Figure 3-1. Block Diagram of Recorder

■ Principle of Monitor Switch (Option)

The internal monitor switch circuit is comprised of a setting section and a comparator section. The setting section generates a reference voltage a setting voltage of 1 – 5V DC. The comparator section compares the PV input signal with the reference voltage, and drives the transistor by the result of comparison.

■ Internal Monitor Switch

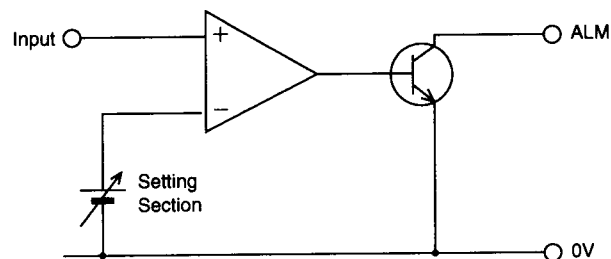

Figure 3-2. Block Diagram of Monitor Switch Circuit

MEMO

Section 4. Installation

4.1 Installation Method

To install the recorder on a panel, proceed as mentioned in the following. (For detail, refer to Section 5 "Operation Method.")

1. Referring to Section 5 "Operation Method," pull out chassis from case and disconnect connector J1 in order to disconnect case from chassis (in order to make the case lighter).
2. Insert case into panel cutout hole, and fix case with clamps supplied.
3. Following in the reverse order the procedure of (1) above, connect connector J1 to chassis and insert chassis into case.

Notes: 1. The recorder is for indoor installation and its chassis is to be pulled forward for servicing. Provide a sufficient space for servicing.

2. Install the recorder in a place where is reasonably free from mechanical vibration.

3. For the panel cutout dimensions, see the drawings at the end of this manual. When a number of mounting holes are cut out closely adjoining in parallel, provide reinforcement to support the recorders.

4. Select a place where the ambient conditions meet those mentioned in Section 2 "Specifications."

4.2 External connection

1. Remove the terminal cover mounted over the rear of the case.
2. Connect the power supply unit and the signal line in accordance with the terminal connection diagram (See the reference drawing attached at the Section 7.3 of this manual).
3. When connecting any load impedance (e.g. the external lamp description) with the alarm contact output, connect the load between the power supply

+ (whether the power supply is commonly used as power for the instrument or it is an separate one) and the alarm contacts + (Terminals ⑬, ⑮, ⑯, ⑰, ⑱ and ⑲).

When driving the integral lamp, shortcircuit between the lamp input terminals (⑥, ⑦, ⑧, ⑨, ⑩ and ⑪) and the alarm contact + the terminal. The lamp is driven from the instrument power in this case. Refer to Figures 4-1 and 4-2.

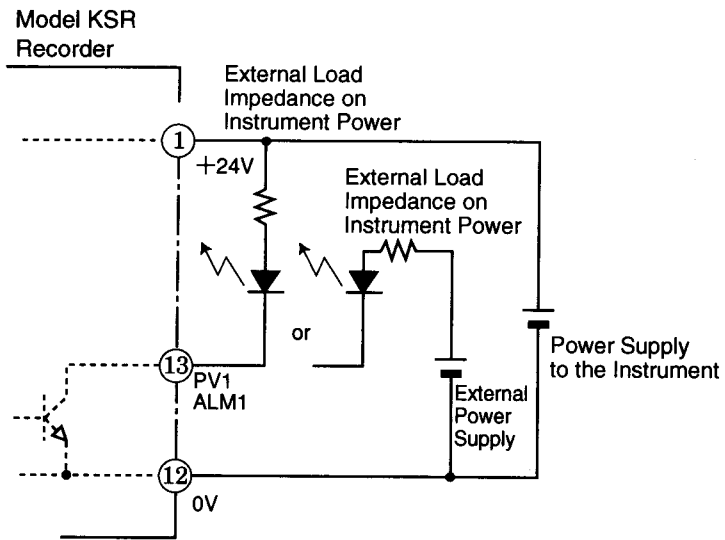

Figure 4-1. Connection Example of Load Impedance

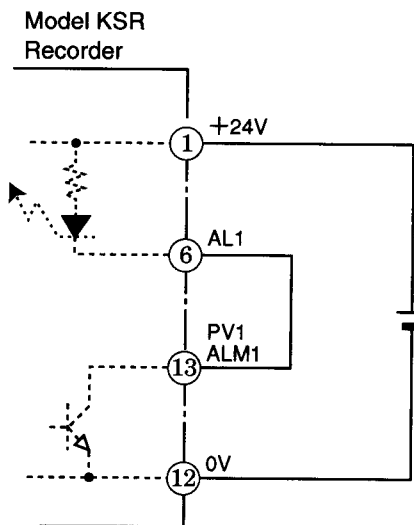

Figure 4-2. Connection Example of Integral Lamps

- Connect the external contact for chart motor start/stop to Terminals ⑳ and ㉔. The chart motor starts when the external contact is turned ON, if the switch SW1 is positioned other than OFF (See Figure 5.21).

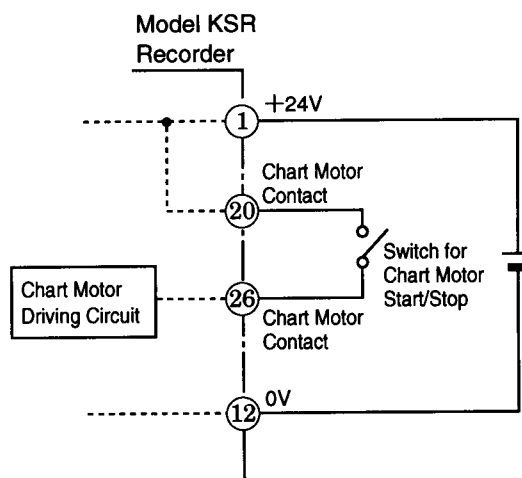

Figure 4-3. Connection of Switch for Chart Mptor Start/Stop

Caution! *The chart paper is apt to be broken, if the recording pen is operated with the chart motor stopped. Refer to Figure 4-3.*

- When the input is electric current (Specification No. Y46), the current signal is converted to voltage one. And a resistance of 250Ω is placed between terminals ㉗ and ㉘, ㉙ and ㉚ and between ㉛ and ㉜ respectively. Each resistance is connected with each of the input terminals of PV1, PV2 and PV3 as required inside the instrument (See Figure 4-4).
Connect the current signal with the input terminals of PV1, PV2 and PV3.

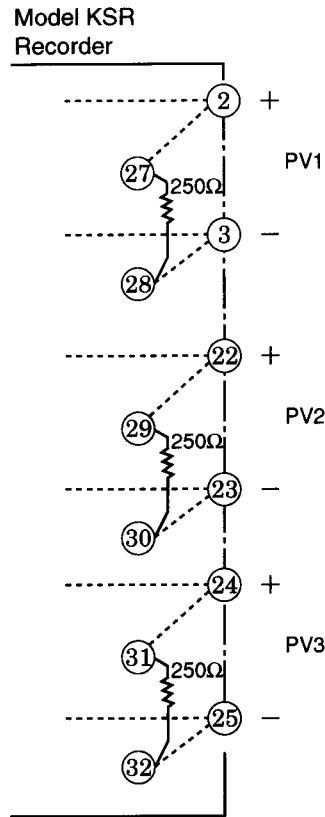
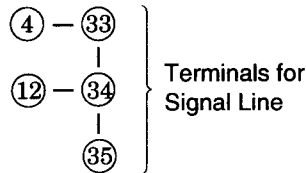

Figure 4-4 . Specifications for Electric Current Input

6. Terminals ④ and ⑫ (common to power supply unit) and terminals ③③, ③④ and ③⑤ (common to signal line) are connected with each other inside the instrument. Refer to Figure 4-5.



The short lines between the terminals denote that the terminals are connected with each other inside the instrument.

Figure 4-5.

Note: When working at the external wiring, refer to "Wiring Procedure No. OM2-2600-0010" for detailed relationship with other instruments in parallel operation.

Section 5. Operation Method

5.1 To Pull Out Chassis from Case

1. Open the door

The door can be readily opened as it is held in position simply with a rubber magnet.

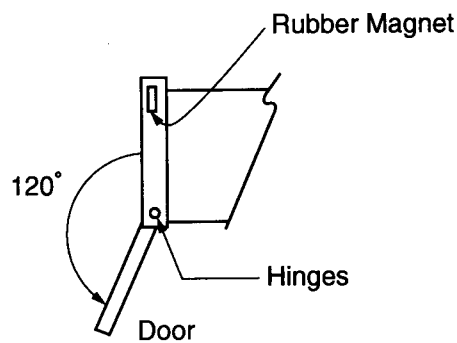

Figure 5-1. Opening the Door

2. Pull out the chassis

- a. Push up the 1st latch located at the bottom of the chassis, and pull out the chassis to the position of the 2nd latch.
- b. Pushing up the 2nd latch on the bottom of the chassis. Pull out the chassis to the 3rd latch position.
- c. Pushing upward the 3rd latch on the bottom of the chassis, disconnect the cable connector from the rear of the chassis. (Figure 5-3-3)

Note: When performing the procedure of steps (b) and (c), hold the chassis with your hand.

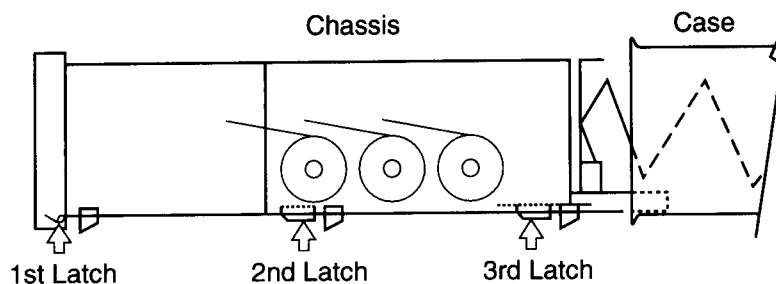

Figure 5-2. Locations of the Latches

3. Remove the chassis completely from the case.
Holding the chassis with one hand, pull up the top of the connector bracket with the other hand. The chassis will be disconnected and the connector bracket will remain in the case.

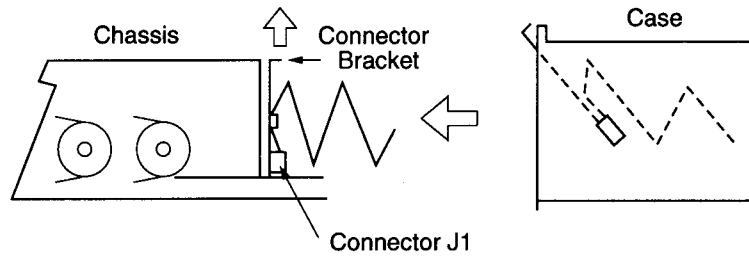

Figure 5-3-1. Connector Bracket

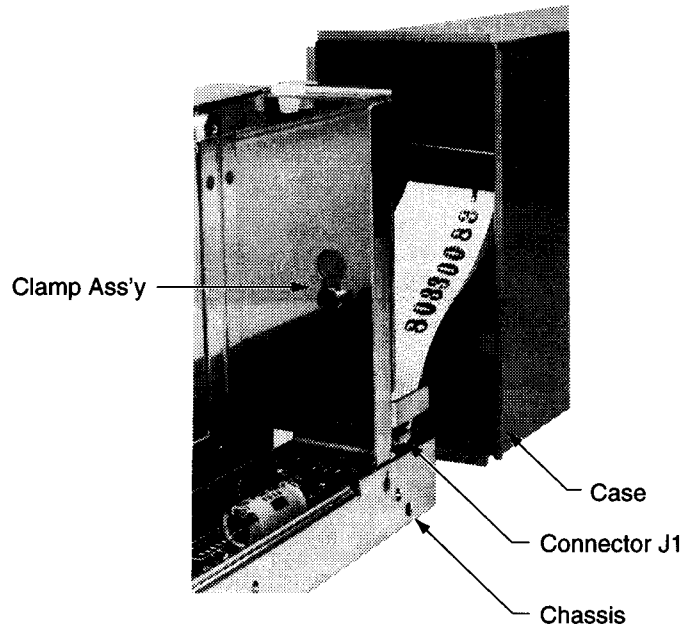

Figure 5-3-2. Clamp Assembly

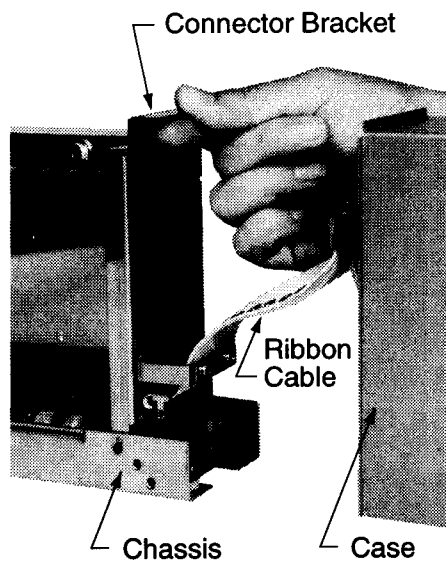

Figure 5-3-3. Pulling up the Connector Bracket

5.2 Chart Paper Replacement

1. Press the latch on the left-hand side as viewed from the chassis front. The chart cartridge will pop out on the opposite side.
-

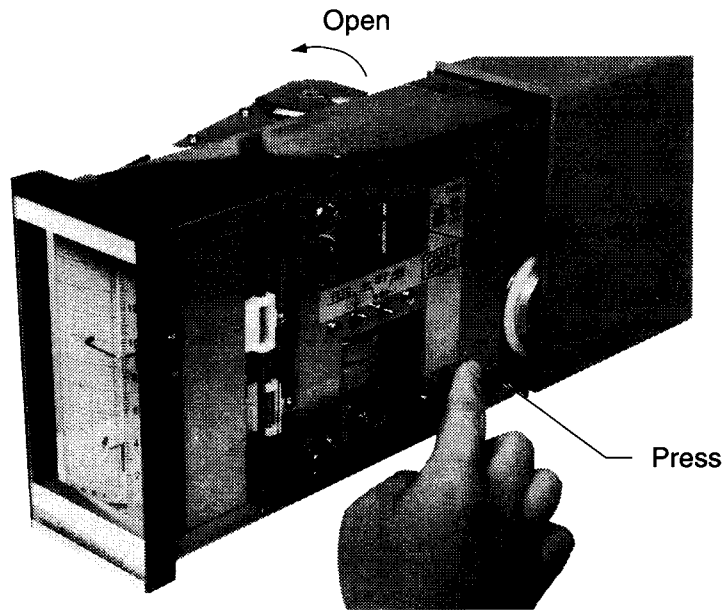

Figure 5-4. Removing the Chart Cartridge (1)

2. **Open the chart cartridge by about 80 degrees**
Holding the chart cartridge with one hand, remove the chart cartridge by pulling up the stud holder with the other hand.
-

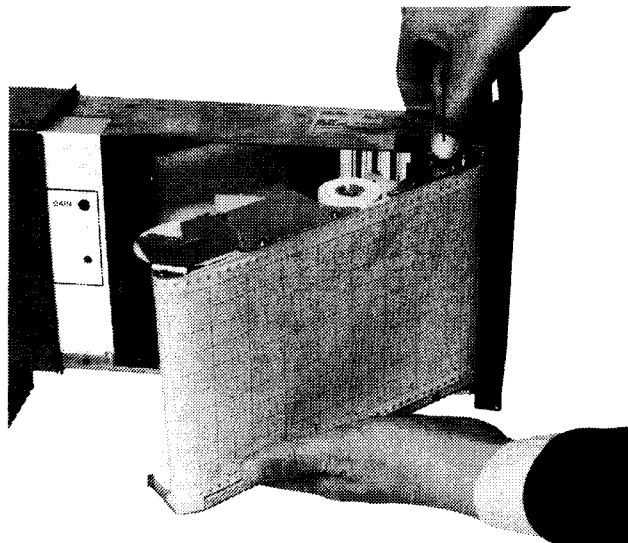

Figure 5-5. Removing the Chart Cartridge (2)

3. Remove the disc of the recorded chart roll

Remove the recorded chart by pulling frontward the disc assembly. The bobbin of the recorded chart is used for the next new chart paper roll for recording. When removing the disc, hold the tube assembly with your hand in order to prevent it from falling down.

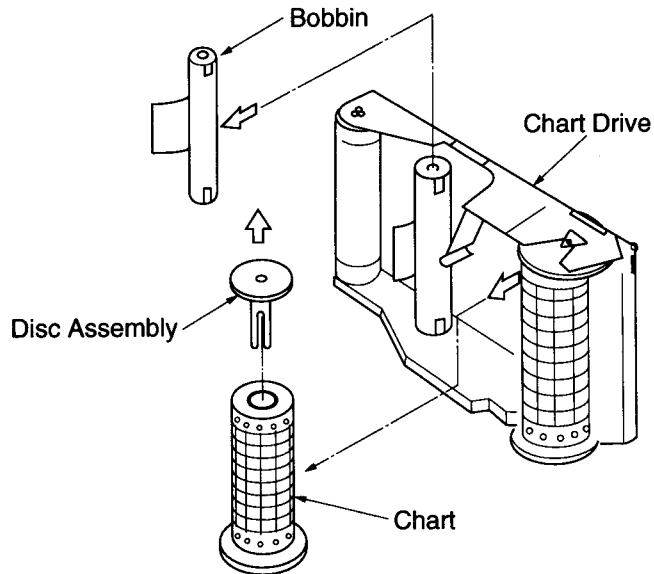

Figure 5-6. Removing the Recorded Chart Paper

4. Install a new chart roll in the chart cartridge

Install on the tube assembly the bobbin that is remaining after the procedure of (3) above. Insert the disc assembly in the tube assembly and make sure that the chart roll is set in the correct position. Install the chart roll in the chart drive assembly.

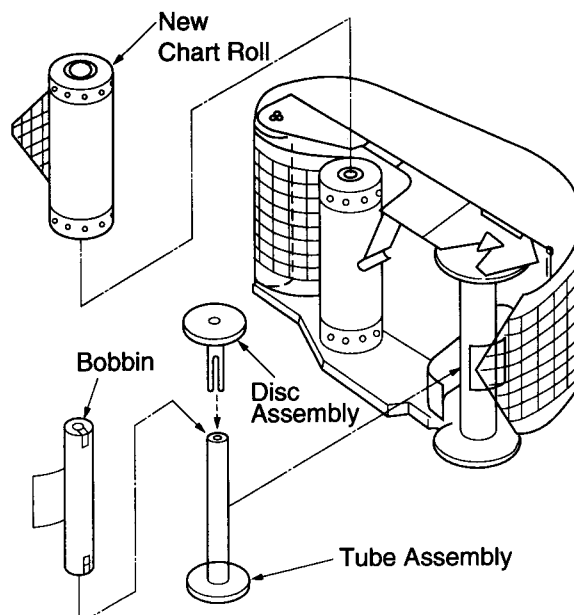

Figure 5-7. Installing Chart Paper (1)

Set the chart paper end to the chart roller of the bobbin and, paying attention so that its end does not extrude, take up chart end by an amount for about one day of operation (about 45 cm).

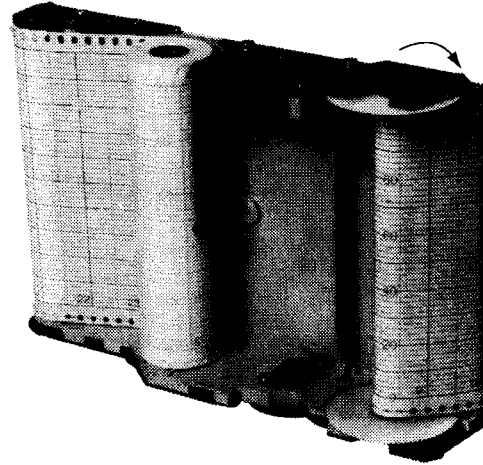

Figure 5-8. Installing Chart Paper (2)

5. Holding the chart cartridge with your hand, open it by approximately 80 degrees, and insert the guide post in the pivot retainer. Next, insert the stud in the stud holder.
-

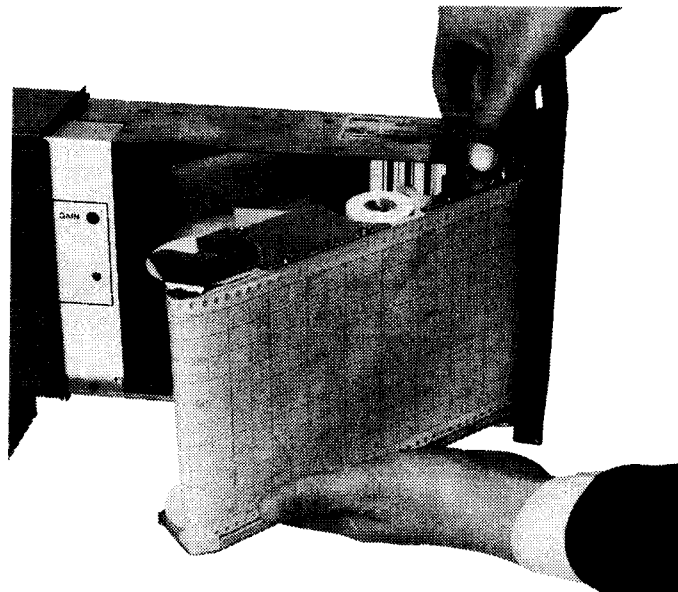

Figure 5-9. Installing the Chart Cartridge in the Chassis (1)

6. Press the cartridge the latch until the cartridge is engaged.
-

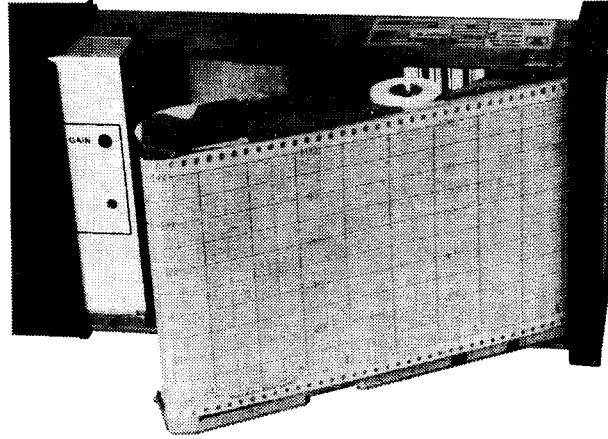

Figure 5-10. Installing the Chart Cartridge in the Chassis (2)
