

Yamatake-Honeywell

OPERATOR'S MANUAL

**DigitroniK Line
PROGRAMABLE CONTROLLER
KMM**

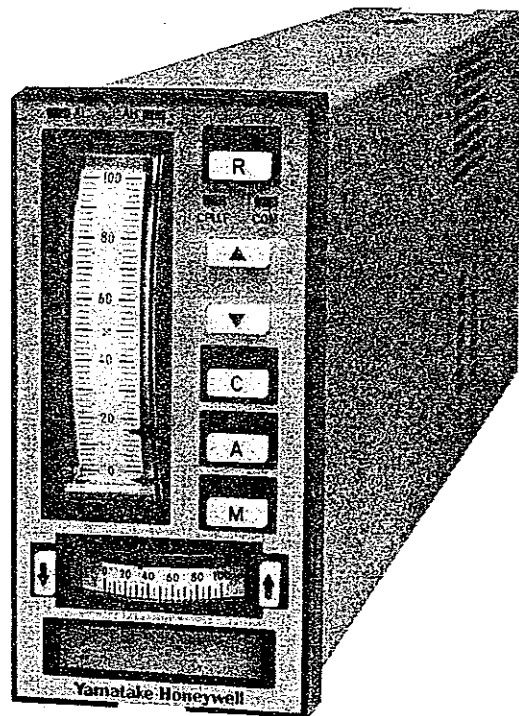

SINGLE STRATEGY CONTROLLER LINE
PROGRAMMABLE CONTROLLER
KMM

1.	GENERAL	1
2.	NOMENCLATURE AND FUNCTIONS OF KMM PANEL ITEMS	2
2.1	Front Panel	2
2.2	Side Panel	5
3.	OPERATION METHOD OF KMM	7
3.1	Front Section of KMM	7
3.2	Operation Method of Data Setting Unit	13
3.3	Auxiliary Switches	38
3.4	Standby Manual Unit	40
3.5	Status Display LED's	45
4.	PREPARATIONS FOR OPERATION OF KMM	46
4.1	Start-up Procedure	46
4.2	Battery Replacement	46
4.3	Electrical Connections	48
4.4	Grounding	57
5.	COMMUNICATIONS FUNCTIONS (OPTIONS)	58
5.1	Types of Communications	58
5.2	Specifying Method of Type of Communications	58
5.3	Types of Communications and Types of Controllers	58
5.4	Computer Mode	58
5.5	Data Which Can be Changed From Communications System	62

1. GENERAL

The DigitroniK Line Programmable Controller (Model KMM) is a digital controller, the level of distribution of functions has been extended to a single control loop in a distributed digital control system. Although compact in construction, it is incorporated with PID control functions and with the various auxiliary arithmetic and control functions.

The Programmable Controller provides an excellent operability which is almost identical with that of the conventional analog instrument, while it allows highly accurate digital setting of control parameters.

The functions to be executed by individual Programmable Controller can be programmed by writing it on the PROM using the Program Loader (KMK 101). For this programming, the required ones can be selected from the pre-stored arithmetic and control functions, and their sequence and their signal flow can be specified as required.

2. NOMENCLATURE AND FUNCTIONS OF KMM PANEL ITEMS

2.1 Front Panel

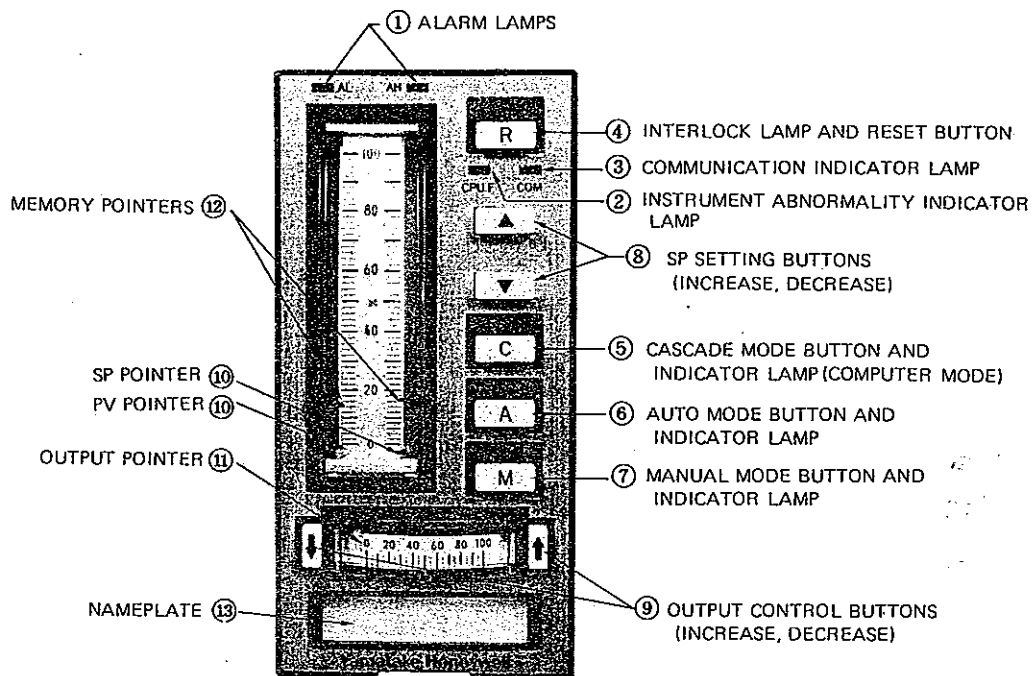

Figure 2.1 Nomenclature of Front Panel Items of KMM

Table 2.1 Functions of Front Panel Items of KMM

No.	Name	Function
①	Alarm lamps (red)	Indicate alarms detected by PVH, PVL or DEV monitors in PID arithmetic unit (selectable with auxiliary switches on side panel). Of the 2PID type instrument, either PID1 or PID2 can be selected (Selectable with switches on side panel).
②	Instrumental abnormality indicator lamp (red)	Lights when KMM has become abnormal and CPU has stopped. Indicates that KMM is in the standby mode. When in this mode, the values indicated by pointers are meaningless.
③	Communication indicator lamp	Lights when in communication operation.
④	Interlock lamp (red and and reset button	When an abnormal state of diagnosis A group (input abnormal), of self diagnostic functions is detected, the lamp lights and the instrument is automatically switched into the interlock manual mode. Also when interlock signal (dedicated DI) is applied the instrument is automatically switched into the interlock manual mode, but in this case the lamp flickers. It lights continuously when the signal is turned off. The lamp goes off as the RESET button is pressed after eliminating the cause of abnormally. When power is turned on (in the initial state), the instrument is in this mode.
⑤	Cascade mode button and indicator lamp (orange)	When this button is pressed, the instrument becomes the cascade mode and this lamp lights. This button is used also to request a computer mode of operation.
⑥	AUTO mode button and indicator lamp (green)	When this button is pressed, the instrument becomes the AUTO mode and the lamp lights. The local set point value can be changed.

No.	Name	Function
⑦	Manual mode button and indicator lamp (red)	When this button is pressed, the instrument becomes the manual mode and the lamp turns on. The output can be manually controlled.
<p>Notes: Model buttons and indications</p> <p>Flickering of a mode indicator lamp denotes transfer to the FOLLOW mode or the destination mode when returning from the FOLLOW mode.</p>		
⑧	SP setting buttons	Buttons for increase (Δ) or decrease (∇) of local set point value. SP setting cannot be done when SP tracking is specified and the instrument is in the manual mode.
⑨	Output control buttons	The analog output can be manually increased with the increase (\uparrow) button or decreased with the decrease (\downarrow) button.
⑩	PV/SP pointers	Indicate the PV signal and SP signal applied to the PID arithmetic unit.
⑪	Output pointer	Indicates the current output.
The displayed signals are as after being subjected to input processing.		
⑫	Memory pointers	Indicate index values of PV and SP when in normal state (steady state) of operation
⑬	Nameplate	---

2.2 Side Panel

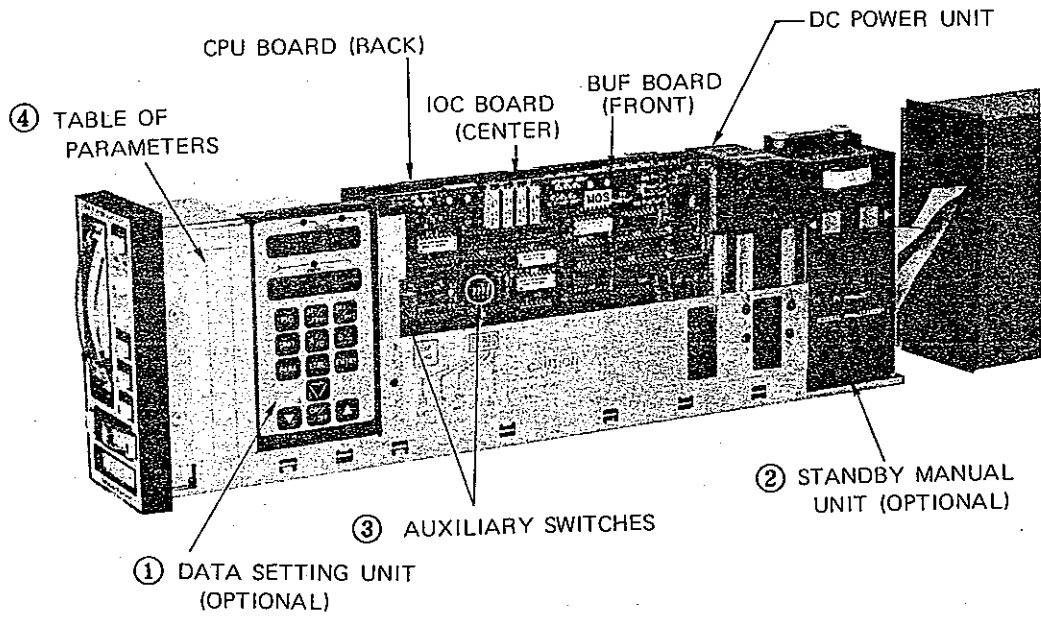

Figure 2.2 Side Panel of KMM

Table 2.2 Functions of Side Panel Items of KMM

No.	Name	Function
①	Data setting unit (optional)	To set control parameters (proportional band, integration time, and derivative time) for PID arithmetic and to change variable parameters, and to indicate the results of PV arithmetic operation and SP. Alarms and results of self diagnosis also are displayed. The data setting unit is detachable. With a single unit, data of other KMM units also can be set. For details, see Subsection 3.2.
②	Standby manual unit (optional)	To manually control the current output when in the standby mode (when in the KMM abnormal state). For details, see Subsection 3.4.
③	Auxiliary switches	For data setting, SP/PV meter indication selection, and other function selection.
④	Table of parameters	To indicate parameter codes and values used for controls.

3. OPERATION METHOD OF KMM

3.1 Front Section of KMM

The basic operation method of the KMM is similar to that of a regular analog controller. For the functions of the instrument front panel items, see Subsection 2.1.

(1) SP Setting

Setting of LSP (local set point) can be done with the SP setting buttons (Δ ∇).

Signals displayed on the meter differ by the type of controller (0 to 3), by the mode of operation, and by the ON/OFF state of the DISP CHG button. The set point indicated by the set point pointer of the meter can be changed by means of the SP setting buttons.

(However, remote SP operation is unavailable.)

Controller Type 0

(1PID Local Type)

Mode \ Pointer	MAN	AUTO
PV pointer	PV1	PV1
SP pointer	LSP1*	LSP1*

*: Can be changed with the SP setting buttons.
(However, it cannot be changed if the PV tracking function is incorporated and the controller is in the MAN mode.)

PV1: PV of PID arithmetic units of primary side

LSP1: Local SP of PID arithmetic unit of primary side

Controller Type 1

(1PID Cascade Type)

Mode \ Pointer	MAN	AUTO	CAS
PV pointer	PV1	PV1	PV1
SP pointer	LSP1* (RSP1)	LSP1* (RSP1)	RSP1

The items enclosed in the parentheses are displayed when the DSP CHG button is pressed.

- *: Can be changed with the SP setting buttons. (However, it cannot be changed if the PV tracking function is incorporated and the controller is in the MAN mode.)

RSP1: Remote SP of PID arithmetic unit of primary side

Controller Type 2

(2PID Local Type)

Mode \ Pointer	MAN	AUTO
PV pointer	PV1 (PV2)	PV1 (PV2)
SP pointer	LSP1* (RSP2)*	LSP1* (RSP2)*

The items enclosed in the parentheses are displayed when the DSP CHG button is pressed.

- *: Can be changed with the SP setting buttons. (However, both LSP1 and LSP2 cannot be changed if the PV tracking function is selected and the controller is in the MAN mode, LSP1 cannot be changed when in the AUTO mode.)

PV2: PV of PID arithmetic unit of secondary side

RSP2: Remote SP of PID arithmetic unit of secondary side

Controller Type 3

(2PID Local Type, with Follow Mode)

Mode \ Pointer	MAN	AUTO	CAS
PV pointer	PV2 (PV1)	PV2 (PV1)	PV1 (PV2)
SP pointer	LSP2* (LSP1)*	LSP2* (LSP1)*	LSP1* (RSP2)

- * Can be changed with the SP setting buttons. (However, LSP1 cannot be changed if PID1 is in the PV tracking operation and the instrument is in the AUTO or MAN mode, or LSP2 cannot be changed if PID2 is in the PV tracking operation and the operation is in the MAN mode.)

LSP2: Local SP of PID arithmetic unit of secondary side.

(2) Control of Output Current

When in the manual mode or interlock manual mode, the output current can be controlled with the output control buttons (↓↑).

(3) Operating Modes of KMM

The KMM has five normal operating modes (MAN, AUTO, CAS, COMP, and FOLLOW modes) and two abnormal operating modes (IM and S modes).

Normal Operating Modes

① MAN (manual mode)

The PID arithmetic unit stops its arithmetic function, the analog output is held, and the output can be controlled with the output control buttons on the instrument front panel. When in this mode, the **[M]** (MAN) lamp on the instrument front panel lights.

② AUTO (automatic mode)

The PID arithmetic unit performs PID arithmetic function with respect to the LSP (local set point) which has been set by the SP control buttons (**[▲]** and **[▼]**) on the instrument front panel. When in this mode, the **[A]** (AUTO) lamp on the instrument front panel lights.

③ CAS (cascade mode)

The PID arithmetic unit performs its PID arithmetic function with respect to an external set point. (in the case of controller Type 2, the output of the primary PID is applied as a target value to the secondary PID arithmetic unit). When in this mode, the **[C]** (CAS) lamp on the instrument front panel lights.

④ COMP (computer mode)

This mode is for SPC control or DDC control with a host computer. The computer mode of operation can be done either in the COMP-AUTO mode (SPC control mode) or in the COMP-MAN mode (DDC control mode). In either case, the **[C]** (CAS) lamp lights.

⑤ FOLLOW (follow mode) (only in the case of Controller Type 3)

The PID arithmetic unit stops its operational function and the output signal follows an external FOLLOW signal (AI2) applied to the instrument. For this mode of operation, a FOLLOW mode switch signal (FLW) and an input signal (FOLLOW signal AI2) which the output signal should follow are needed. When the instrument operation is switched to the FOLLOW mode, the mode lamp corresponding to the mode existed immediately before switching starts flickering; the lamp lights continuously when the FOLLOW mode switching signal is released.

Abnormal Operation Modes

① IM (interlock manual mode)

Instrument operation is transferred into this mode if an analog input rangeover is detected by the diagnostic function when in

the normal (MAN, AUTO, CAS, COMP, or FOLLOW) mode of operation, if the standby mode selector switch is set to the STANDBY state, or if an external interlock signal (INT'K) as an external cause is applied. The apparent functions are the same with those of the manual mode. Once the instrument has fallen into this mode, it cannot be changed to other mode unless the [R] (RST) button is pressed after eliminating the cause of the mode change. (As the [R] (RST) button is pressed, the instrument is reset to the manual mode.)

When in the initial state (when the power is initially turned on after installing the KMM or when the power is turned on again), the instrument is invariably set to this state. When in the manual mode or interlock manual mode, LSP (local set point) can be changed. But LSP cannot be changed in the PV tracking function is selected.

When the instrument is changed into the interlock manual mode by an external cause, the INTERLOCK lamp on the front panel flickers; it lights continuously when the interlock signal is released. When the instrument is changed into this mode by an internal cause, the lamp lights continuously.

2 S (standby mode)

The instrument operation is transferred into this mode if an abnormal state is detected by the self-diagnosis function of KMM when the instrument is in normal operation mode or in the IM mode.

When in this mode, the instrument output (A01) can be controlled with the standby manual unit (optional). Two types of standby manual units are available and either one of them can be installed in the instrument.

1. Preset type (hardware manual)

When changed to the standby mode, the instrument delivers the output of a preset value. Subsequent operation can be done with the standby manual unit.

2. Follow up type (software manual)

When changed to the standby mode, the instrument output is held at the value which existed immediately before changing to the standby mode. Subsequent operation can be done with the output control buttons on the KMM front panel or with the output control knob on the standby manual unit.

Once the instrument has been changed to the standby mode, it cannot be changed to other mode unless the cause of the change is eliminated. (When the instrument is repaired and the power is turned on, the instrument operates in the IM mode.) When the instrument is in the standby mode, the mode is displayed by the [] lamp on the front panel.

CPUF

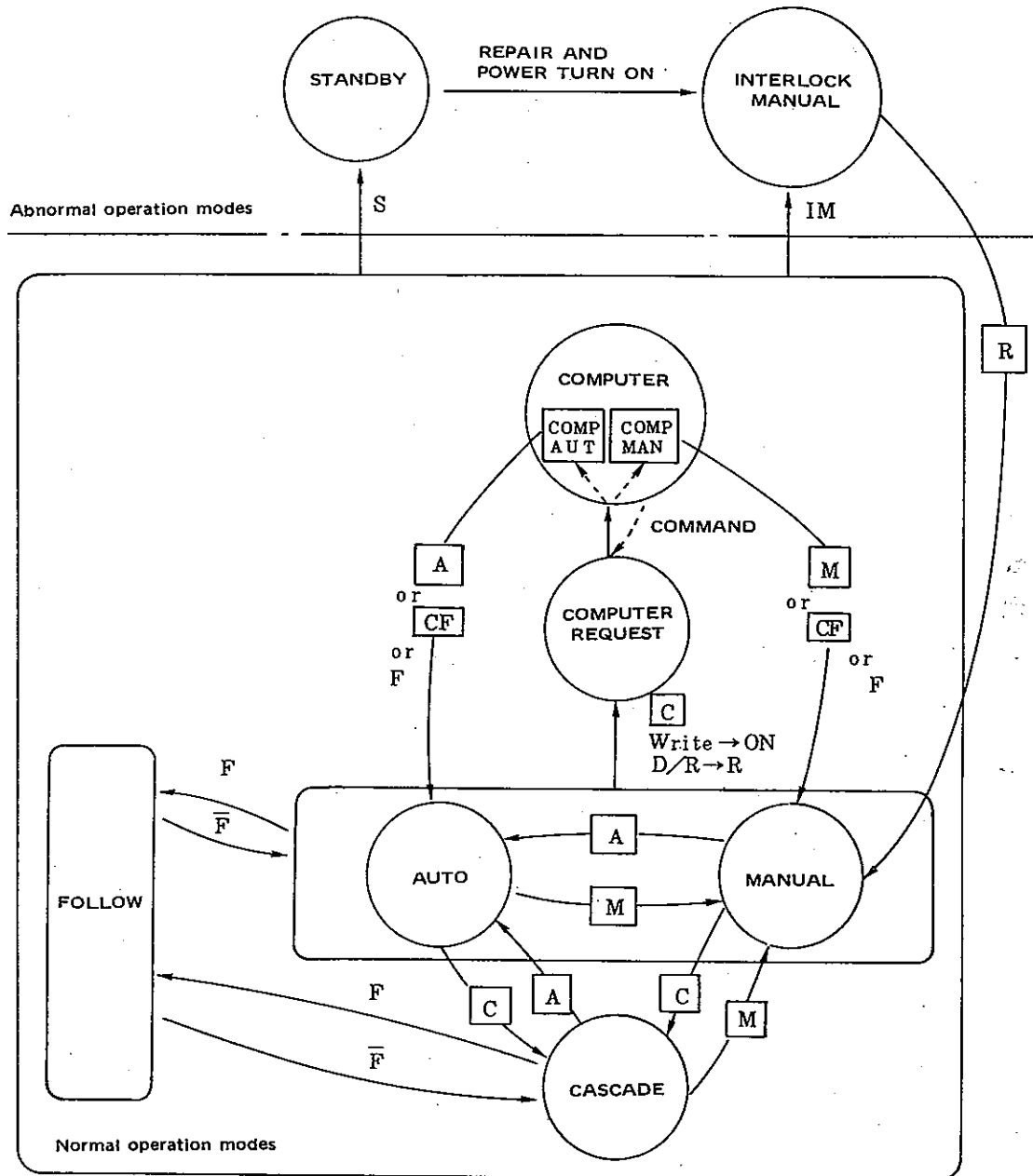

- C** : Cascade (computer) mode button
- A** : AUTO mode button
- M** : MANUAL mode button
- F** : FOLLOW mode select signal (for Controller Type 3 only)
- F̄** : FOLLOW mode select signal release (for Controller Type 3 only)
- IM** : External interlock signal or internal cause
- S** : Instrument abnormal state detection by self diagnosis
- CF** : Computer failure
- R** : Reset button

Figure 3.1 Mode Transfer Chart

(4) Indicator Lamps

The KMM has the following lamps in addition to the mode indicator lamps:

- o Alarm lamps (AH, AL)
- o Instrument abnormality indicator lamp (CPU. F)
- o Interlock lamp
- o Communication indicator lamp (COM)

When the instrument abnormality indicator lamp is turned on, the KMM is changed to the standby mode. (See Subsection 3.4 "Standby Manual Unit.") The cause of abnormality is displayed on the data setting unit. (See Subsection 3.2.3 "Alarm Display and Self-diagnosis Display.")

3.2 Operation Method of Data Setting Unit

The Data setting unit of KMM is installed on the instrument side panel. The unit is a digital setting and display unit which sets data for control and arithmetic operations and display the required data.

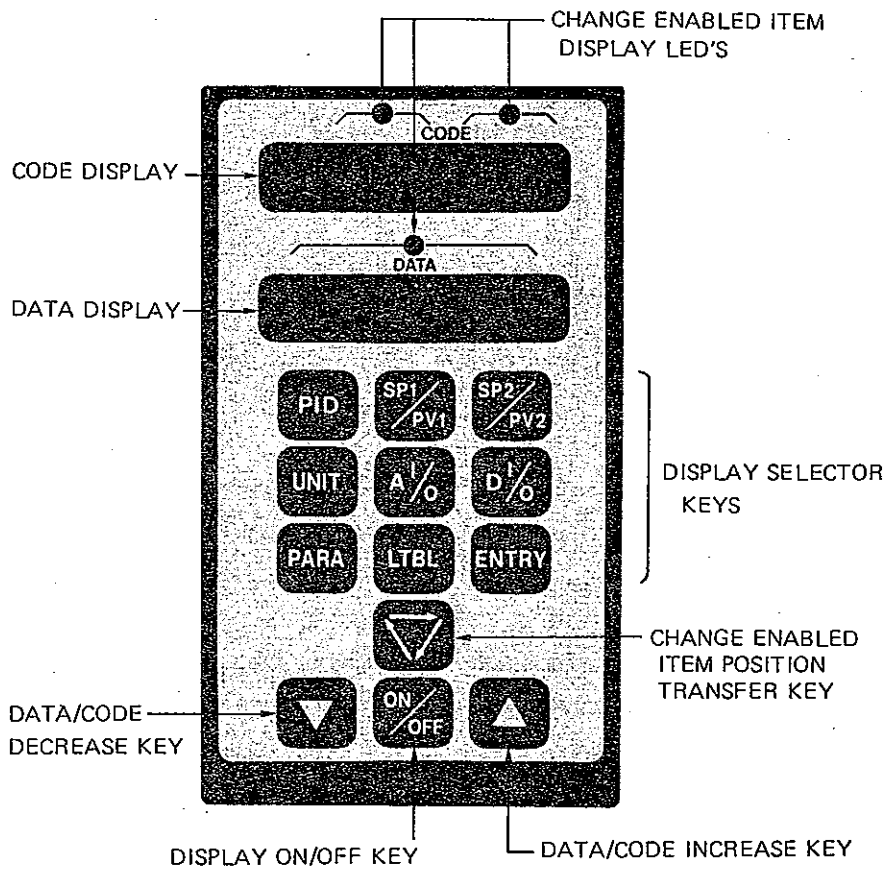



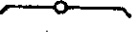

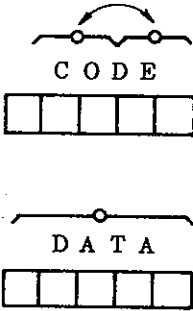
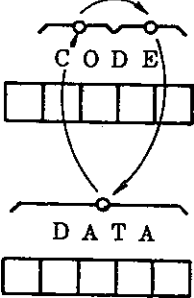





Figure 3.2 Data Setting Unit of KMM

3.2.1 Functions of Keys

Table 3.2 Functions of Keys of Data Setting Unit

Key	Function
PID	To call PID arithmetic operation parameters, etc.
SP1/PV1	<p>To call SP1 (set point value) of PID1 or PV1 (measured process variable value)</p> <div style="display: flex; justify-content: space-around; align-items: center;"> <div style="text-align: center;">  <p>CODE</p> <div style="border: 1px solid black; padding: 2px; width: 100px; margin: 0 auto;">SP1 DISPLAY</div> </div> <div style="text-align: center;">  <p>DATA</p> <div style="border: 1px solid black; padding: 2px; width: 100px; margin: 0 auto;">PV1 DISPLAY</div> </div> </div>
SP2/PV2	<p>To call SP2 (set point value) of PID2 or PV2 (measured process variable value)</p> <div style="display: flex; justify-content: space-around; align-items: center;"> <div style="text-align: center;">  <p>CODE</p> <div style="border: 1px solid black; padding: 2px; width: 100px; margin: 0 auto;">SP2 DISPLAY</div> </div> <div style="text-align: center;">  <p>DATA</p> <div style="border: 1px solid black; padding: 2px; width: 100px; margin: 0 auto;">PV2 DISPLAY</div> </div> </div> <p>For 1PID type instrument, display is -----.</p>
UNIT	To call input/output data of arithmetic unit.
A %	To call analog input/output data.
D %	To call digital input/output.
PARA	To change parameters.
LTBL	To call broken-line data.
ENTRY	To enter data for setting or change. This key is effective when the auxiliary "data entry enable switch" is kept in the "on" (ON) state.

Key	Function
	<p data-bbox="352 360 1318 421">To transfer the lighted position of the change enabled item display LED's.</p> <div style="display: flex; justify-content: space-around; align-items: center;"> <div style="text-align: center;">  <p data-bbox="379 902 724 936">① Display data only</p> </div> <div style="text-align: center;">  <p data-bbox="810 902 1209 965">② Data which can be set or changed</p> </div> </div>
<div style="display: flex; flex-direction: column; align-items: center;"> <div style="margin-bottom: 10px;">  <p data-bbox="113 1160 264 1189">(INCREASE)</p> </div> <div>  <p data-bbox="113 1323 264 1352">(DECREASE)</p> </div> </div>	<p data-bbox="347 1066 1273 1126">To increase or decrease value for data setting and change or for code display and change.</p>
	<p data-bbox="347 1417 951 1447">To turn on or off the display section</p>



3.2.2 Data Call and Change



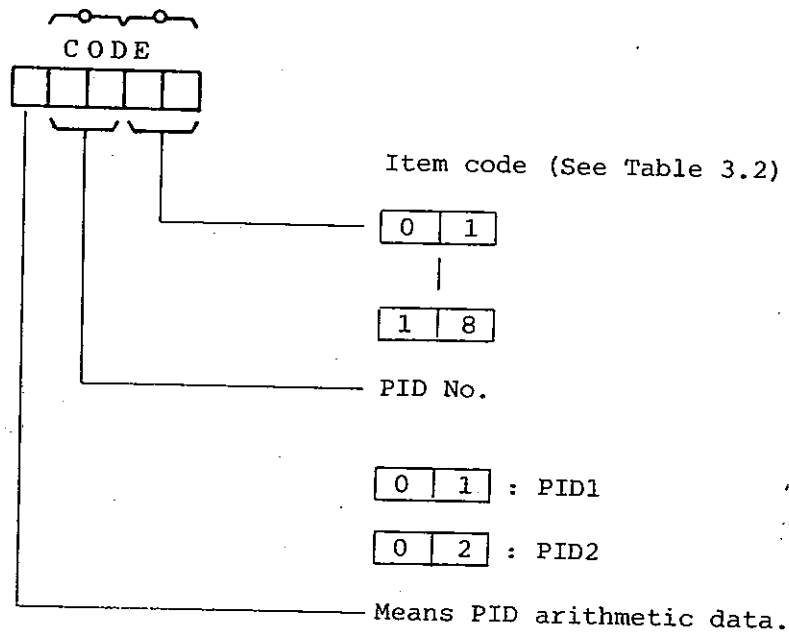

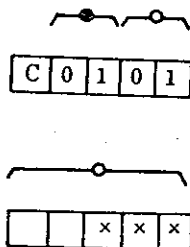

The set control data can be displayed by calling with a code the item required to be displayed. Some control data are for display only; others are for setting change also.

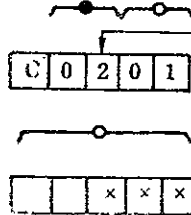

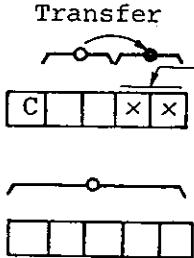

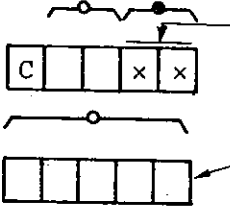

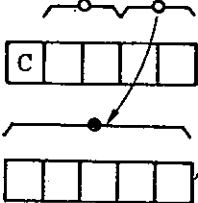
(1) Call and Change Method of PID Arithmetic Parameters

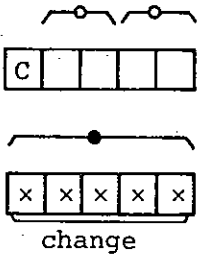

C

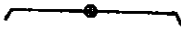

Step No.	Procedure	Display
1	Press the  button.	 <p>"C" of code display part denotes PID. Next "01" denotes PID1. Next "01" denotes 1st parameter (proportional band).</p> <p>Contents of code number "C0101" (proportional band of PID1) are displayed in the data display part.</p>
2	To change parameter of PID2, the  button once. (This procedure is not needed when changing parameter of PID1.)	 <p>Code display part is changed to "C0201" and proportional band of PID2 is displayed in the data display part.</p>

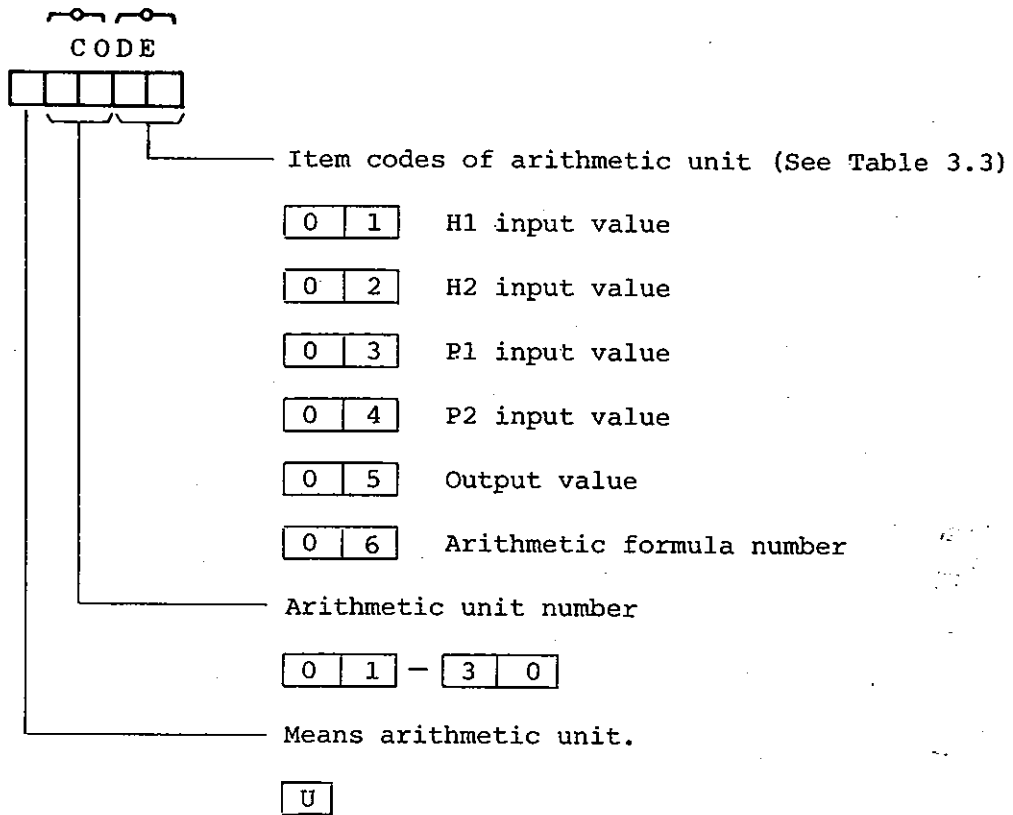

Step No.	Procedure	Display
3	Press once the  button to move the "changeable digit indication LED".	 <p>Transfer</p> <p>Means that two low digits of code display part are changeable. (The two low digits of the code display part denote parameter number. See Table 3.2.)</p>
4	Press the  (or ) button so that parameter number increases (or decreases) and the number of the parameter which is to be changed is displayed.	 <p>The number of the parameter which is to be changed is displayed and the value of the parameter is displayed and the value of the parameter is displayed in the data display part.</p>
5	To change value, press again the  button to move the "changeable digit indication LED" to the data display part.	 <p>The data display part becomes changeable.</p>
6	Change data by pressing the  (or ) button.	 <p>change</p> <p>Display only is changed. Internal data is not changed yet.</p>

Step No.	Procedure	Display
7	<p>Set the "ENT Enable" auxiliary switch on the side panel to the ENT state. (On state)</p>  <p>↑ ENT</p> <p>Then, press the  button.</p>	    <p>As the change request is accepted, display goes off for a short period.</p>

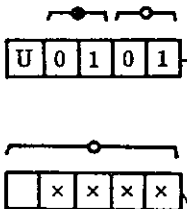
(2) Call Method of Arithmetic Unit

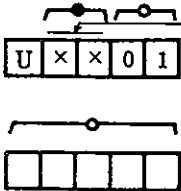

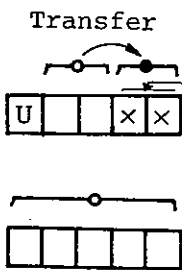

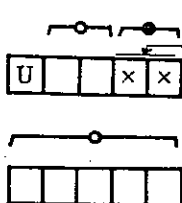



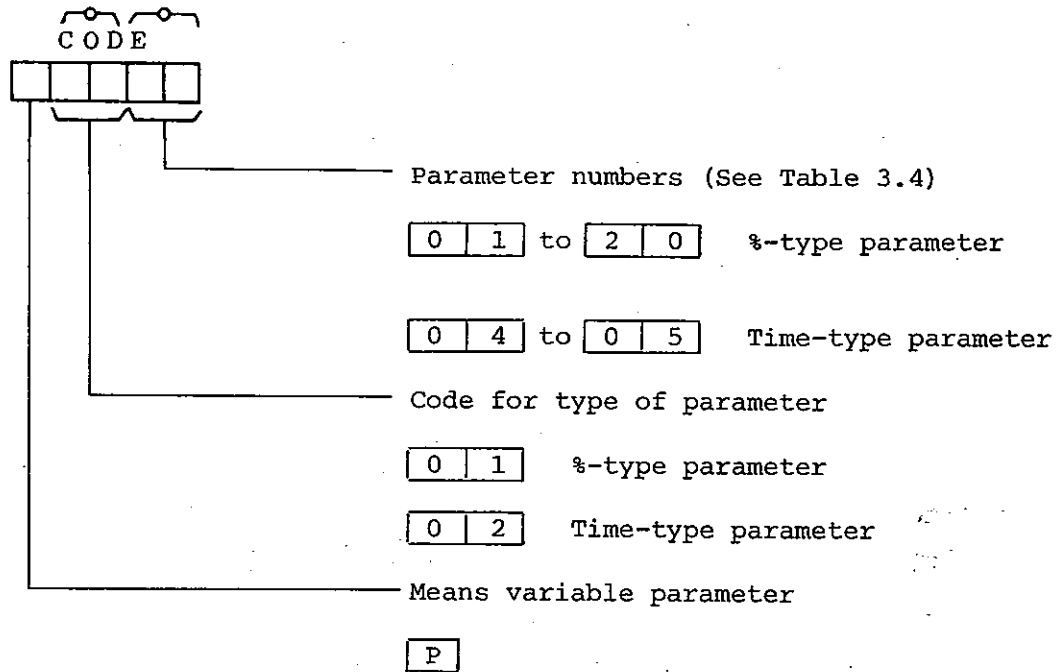

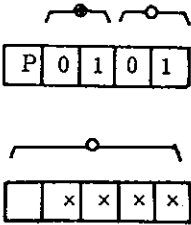

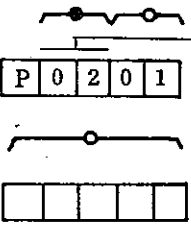

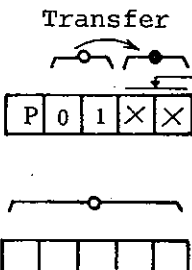
Step No.	Procedure	Display
1	Press the  button.	 <p>"U0101" is displayed in the cord display part. U01 denotes "Arithmetic Unit." The next 01 denotes parameter number 1 "H1 input."</p> <p>"H1 input value" is displayed in the unit of % in the data display part.</p>
2	Select the desired arithmetic unit number by pressing the  (or )	 <p>Arithmetic unit number increases (or decreases).</p>

Step No.	Procedure	Display
3	Press the  to move the "changeable digit indicator LED."	<p>Transfer</p>  <p>Becomes a state that parameter number is changeable.</p>
4	Select the desired parameter number by pressing the  (or ) button.	 <p>As parameter number is set, data is displayed in the data part.</p>
<p>Note: The data items of the arithmetic units are for display only. They cannot be changed.</p>		

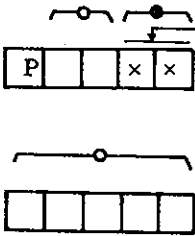
(3) Call and Change Method of Variable Parameters

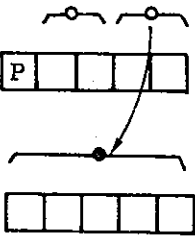

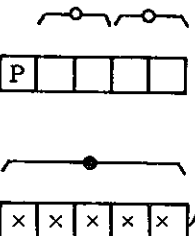

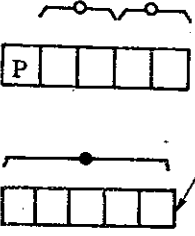



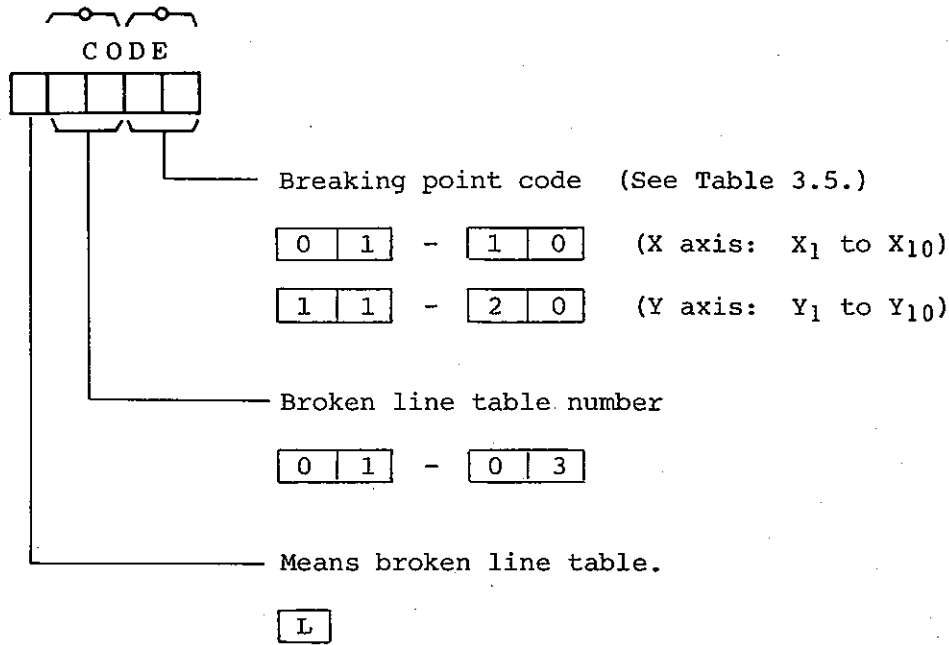

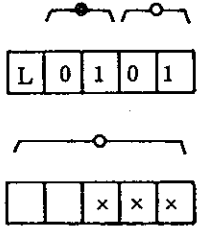

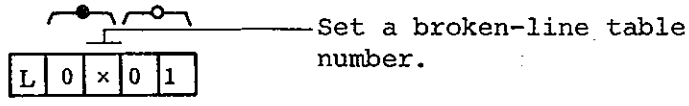

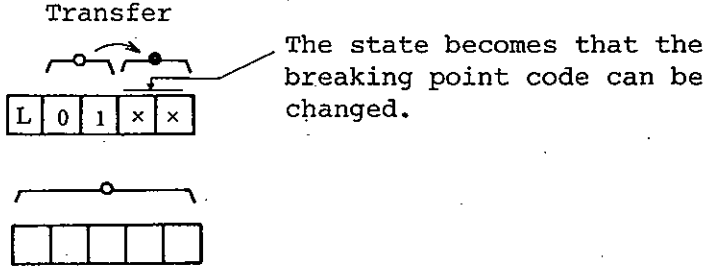
Step No.	Procedure	Display
1	Press the  button.	 <p>%-type parameter is displayed.</p>
2	For a time-type parameter, press also the  button to call "P02XX".	 <p>"02" denotes a time-type</p>
3	Transfer the lighted position of LED by  pressing the button.	 <p>Transfer</p> <p>The state becomes that parameter number is changeable.</p>

Step No.	Procedure	Display
4	Select (call) the desired parameter number by pressing the  (or ) button.	 <p>As the parameter number is set, data is displayed in the data display part.</p>
5	Press  button to transfer the lighted position of LED.	<p>Transfer</p> 
6	Change to the desired data by pressing the  (or ) button.	 <p>Display alone is changed. Internal data is not changed yet.</p>
7	Set the "ENT Enable" auxiliary switch on the side panel to the ENT state (ON state)  ENT Next, press the  button.	 <p>As the change request is accepted, display goes off for a short period.</p>

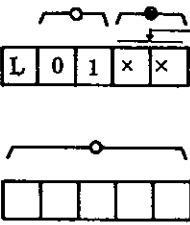
(4) Call and Change Method of Broken Line Table

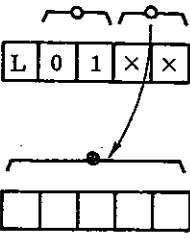

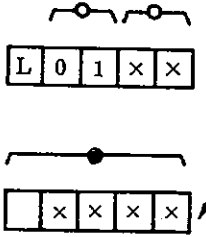
Step No.	Procedure	Display
1	Press the  button.	 <p>Coordinate (X axis) of broken line No. 1 is displayed.</p>
2	To call a broken-line table for No. 2 or No. 3, press the  button and set a broken-line number.	 <p>Set a broken-line table number.</p>
3	Transfer the lighted position of LED by pressing the  button.	<p>Transfer</p>  <p>The state becomes that the breaking point code can be changed.</p>

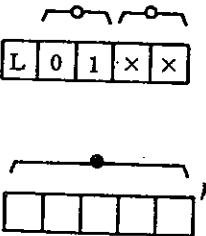
Step No.	Procedure	Display
4	Select the desired breaking point code by pressing the  (or ) button.	 <p>As the breaking point code is set, coordinate of the breaking point is displayed in the data display part.</p>
5	Transfer the lighted position of LED by pressing the  button.	 <p>The state becomes that the coordinate of breaking point can be changed.</p>
6	Change the data to the desired value by pressing the  (or ) button.	 <p>Display of the data display part only is changed. Internal data is not changed yet.</p>
7	Set the "ENT Enable" auxiliary switch to the "ENT" state (ON state).  ENT Then, press the  button.	 <p>As the change request is accepted, display goes off for a short period.</p>

(5) Call Method of SP1/PV1

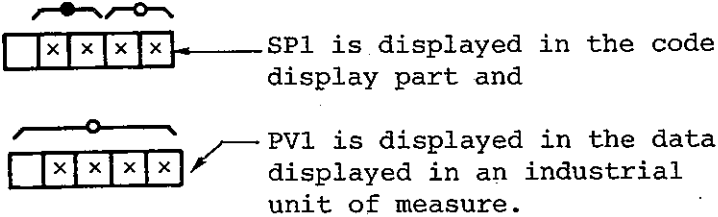
Step No.	Procedure	Display
1	Press the  button.	 <p>SP1 is displayed in the code display part and</p> <p>PV1 is displayed in the data displayed in an industrial unit of measure.</p>

(6) Call Method of SP2/PV2

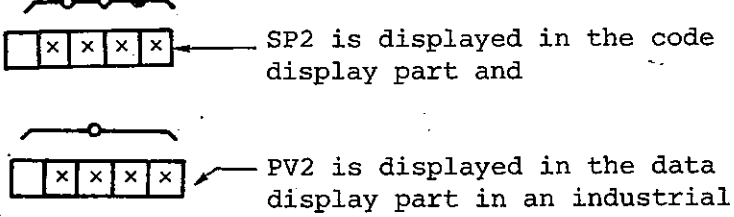



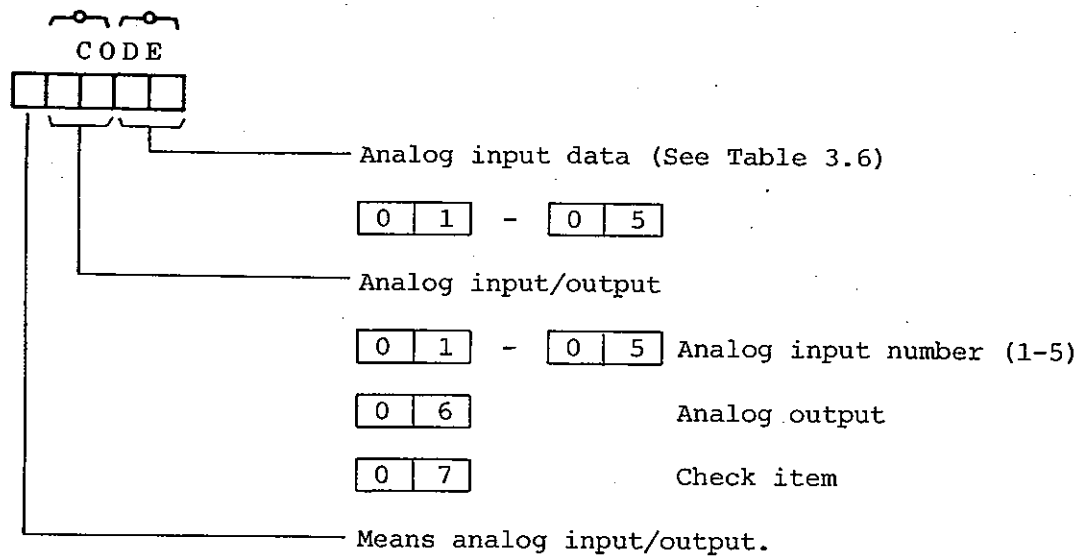

Step No.	Procedure	Display
1	Press the  button.	 <p>SP2 is displayed in the code display part and</p> <p>PV2 is displayed in the data display part in an industrial unit of measure.</p>



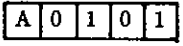
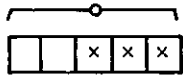

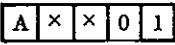

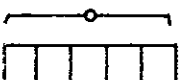

Note: When PID1 alone is used, display of SP2/PV2 is .

(7) Call and Change Method of Analog Input/Output Signals

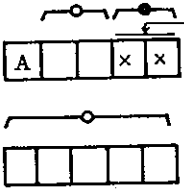

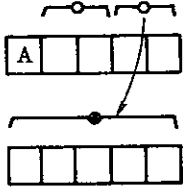
A

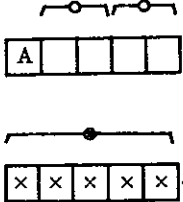
Step No.	Procedure	Display
1	Press the  button.	 
2	To call analog input No. 2, press the  button and set the display to "A02XX"-"A07XX".	 
3	To call other item of data related to the analog input, transfer the lighted position of LED by pressing the  button.	<p>Transfer</p>  

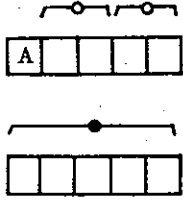
Step No.	Procedure	Display
4	Select the desired item code by pressing the  (or ) button.	 <p>The items indicated by the asterisks are variable.</p> <ul style="list-style-type: none"> 01: Raw input 02: Value after input processing *03: Digital filter value *04: Industrial unit range (low limit) *05: Industrial unit range (high limit)
5	To change data, set "AXXXX" in the code display part and then transfer the lighted position of LED by pressing the  button.	 <p>The state becomes that data can be changed.</p>
6	Change the data to the desired value by pressing the  (or ) button.	 <p>Displayed data only is changed. Internal data is not changed yet.</p>
7	Set the "ENT Enable" auxiliary switch on the side panel to the "ENT" state. (ON state)  Then, press the  button.	 <p>As the change request is accepted, display goes off for short period.</p>

(8) Call Method of Digital Input/Output Signals

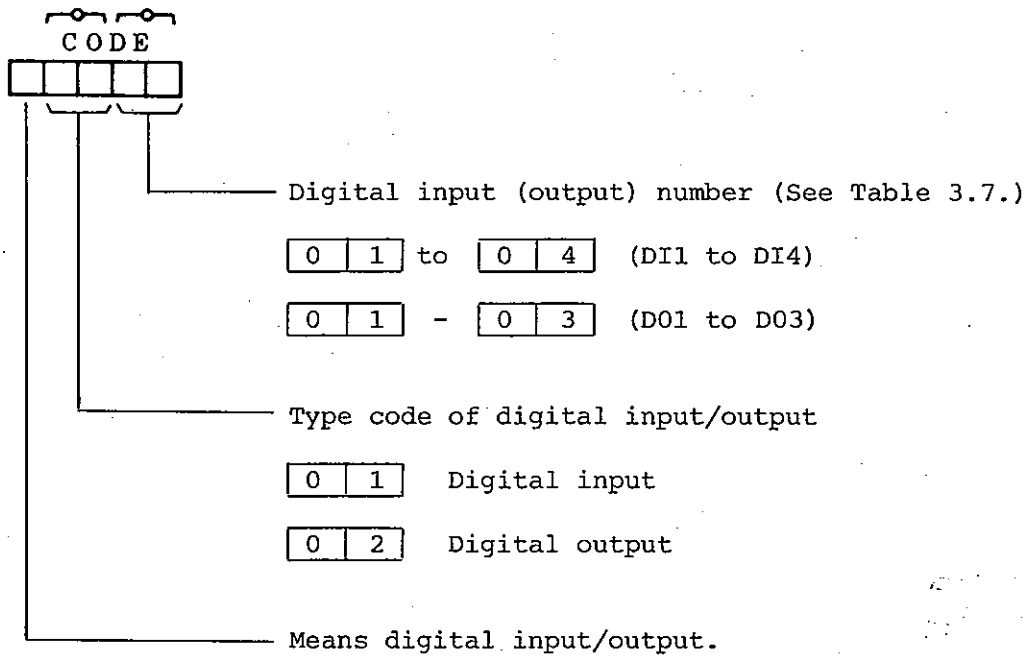

d

Step No.	Procedure	Display
1	Press the button.	<p>The input status of the digital input is displayed.</p> <p>0: OFF 1: ON</p>
2	In the case of digital output press also the button.	
3	Transfer the lighted position of LED by the pressing the button.	<p>Transfer</p> <p>The state becomes that input or output can be changed.</p>



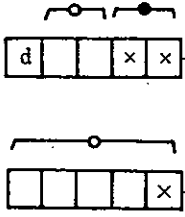
Step No.	Procedure	Display
4	Press the  (or ) button and select a digital input (output) number.	 <p data-bbox="1002 353 1358 414">Digital input (output) number</p> <p data-bbox="1002 481 1394 542">Input (output) status is displayed at data part.</p> <p data-bbox="1002 577 1117 638">0: OFF 1: ON</p>

Table 3.2 Parameter Codes for PID Arithmetic Operation

Code	Contents	Display (setting) Range	Unit	Setting Change
C01xx	PID1	-	-	0
C02xx	PID2	-	-	0
C0x01	Proportional band	0.0 to 799.9	%	0
02	Integration time	0.00 to 99.9	Minute	0
03	Derivative time	0.00 to 99.99	Minute	0
04	Integration limit (low limit)	-699.9 to 799.9	%	0
05	Integration limit (high limit)	-699.9 to 799.9	%	0
06	Ratio	-699.9 to 799.9	%	0
07	Bias	-699.9 to 799.9	%	0
08	Dead zone	-699.9 to 799.9	%	0
09	Output change rate	-699.9 to 799.9	%	0
10	Deviation alarm	-699.9 to 799.9	%	0
11	PV alarm (low limit)	(Industrial unit display)	Industrial unit	0
12	PV alarm (high limit)	(Industrial unit display)	Industrial unit	0
13	PV	-6.9 to 106.9	%	x
14	RSP (remote SP)	-6.9 to 106.9	%	x
15	LSP (local SP)	-6.9 to 106.9	%	x
16	SP (SP for arithmetic operation)	-6.9 to 106.9	%	x
17	Deviation (SP - PV)	-6.9 to 106.9	%	x
18	PID arithmetic opera- tion output	-6.9 to 106.9	%	x