

MX200

SUPER MACHINE CONTROLLER

USER'S MANUAL

Specifications and Installation

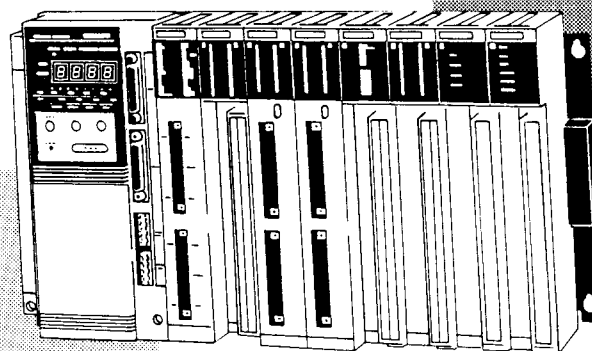

Notes to Users

Please ensure that this manual is handed over to the end user.

This manual is indispensable to first time users of the MX200 controller and should be retained for future reference.

This manual may not be reproduced or transmitted wholly or in part in any form whatsoever without prior permission.

The contents of this manual are subject to change without prior notice.

Great effort has been taken to ensure that the contents of this manual are correct. Should you, however, notice any errors or inconsistencies, we would be grateful if you informed us.

Yamatake - Honeywell shall not be liable for any damages that result from the use of the product.

Printed in Japan © Copyright 1994 by **Yamatake-Honeywell Co. Ltd.**

The MX200 Super Machine Controller, MX100 Machine Controller, MX30 One-Board Machine Controller, ST100/220 Smart Terminal, ASCII Adapter, Remote I/O and POP Adapter are all trademarks of Yamatake - Honeywell.

MS-DOS® is a registered trademark of Microsoft Corporation.

Foreword

Thank you for purchasing the MX200 Super Machine Controller.

This user's manual describes installations, connections, specifications and how to deal with problems that may occur in operating the MX200.

The manual also contains information on how to use the MX200 correctly. It should be read by those who design and maintain devices and operator control panels that use the MX200 controller.

The Role of This Manual

This user manual provides installation and connection methods, inspection procedures, countermeasures to solve problems and hardware specifications needed to install and connect the MX200 Super Machine Controller when it is integrated in other equipment.

All the manuals that accompany the MX200 Super Machine Controller are listed below and followed by a brief outline.

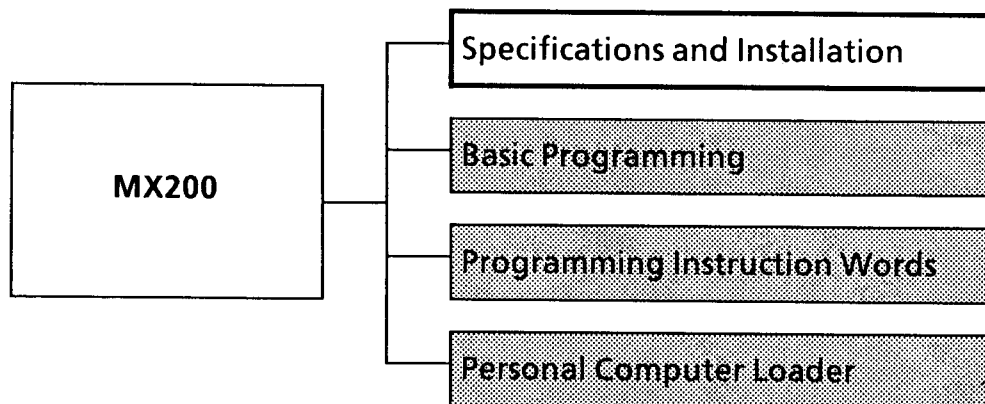

Basic Programming

CP-UM-1562E

This manual contains the basics of program writing and programming techniques and provides information on the register and memory structure of the MX100 and MX200.

Programming Instruction Words

CP-UM-1563E

This manual is required reading for programmers who write programs for the MX200 Super Machine Controller.

It gives detailed explanations of each instruction word and can therefore also be used for reference.

Personal Computer Loader

CP-UM-1602E

This manual is required reading for those who write programs for the MX200 Super Machine Controller.

This manual comes with a loader software package supplied on floppy disks. The loader software package supports the MX100, MX200 and MX30, and runs on a PC-9801 series personal computer. The manual describes how to create an "execution system disk" and how to operate the loader.

Configuration of the User's Manual

As shown in the figure below, the first page of each chapter contains a black tab to facilitate the location of the chapters.

Chapter 1 GENERAL

This chapter describes the features and functions of the MX200 and provides a list of components and information on system configurations.

Chapter 2 PARTS AND FUNCTIONS OF COMPONENTS

This chapter describes the parts and functions of the MX200 base, processor modules and I/O modules.

Chapter 3 INSTALLATION AND WIRING

This chapter covers cautions in installing the MX200, installation environment, installation procedures, input and output circuits for the I/O module and connections to external equipment.

Chapter 4 OPERATION

This chapter describes inspections to be made before operation and how to perform a trial run.

Chapter 5 MAINTENANCE AND INSPECTIONS

This chapter describes inspections and how to replace service parts to keep the controller in good working condition and ensure long service life.

Chapter 6 TROUBLESHOOTING

This chapter provides procedures for solving problems that may occur while operating the MX200.

Chapter 7 SPECIFICATIONS

This chapter provides general specifications, performance specifications, a list of instruction words and external dimensions.

Description of Symbols Used in This Manual

The following symbols are used in this manual.

□ or ○ : Indicates that an LED on an MX200 processor module is on.

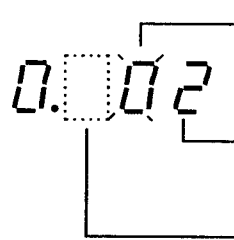

■ or ● : Indicates that an LED on an MX200 processor module is off.

◻ or ◐ : Indicates that an LED on an MX200 processor module is flashing.

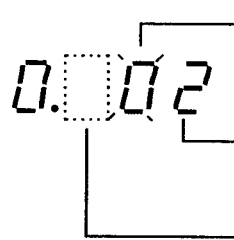
 : Indicates that an item on an MX200 processor module indicator is flashing.

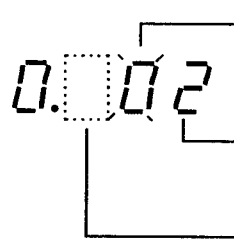
 : Indicates that an item on an MX200 processor module indicator is displayed.

 : Indicates that an item on an MX200 processor module indicator is not displayed.

[DISP]、 [ENTER]、 [RESET]、  、  : Indicates keys on MX200 processor modules.

◇Note◇ Notes contain special-attention text that highlights information on handling or operation procedures. These instructions should be read.

◇Tip◇ Tips provide information on convenient features.

Unpacking and Checking Contents

When you open the package, check the following.

1. Check the model numbers to make sure that you have received all the products you ordered.
2. Check the appearance of the product for damages.
3. Check that all accessories have been delivered.

If any of the ordered products are missing or defective, contact your dealer.

The table below is a list of all the accessories provided with each module. When all the items have been unpacked, make sure that they are not lost or damaged.

Product	Accessories	Quantity	Remarks
Processor modules MX200CP01 MX200CP01T MX200CP01P	Short bar	2	
	Lithium battery MX100BT01	1	Mounted in main unit at factory before shipment
	2 A fuse MX100FS01	2	Spare fuses
I/O modules MX100GT01 MX100GT02 MX100GT31 MX100GT32 MX100GT11 MX100GT12 MX100GT14 MX100GT15 MX100GT75 MX100GT78 MX100PT12 MX100PT42 MX100PT72 MX100PT21 MX100PT22 MX100GP12	I/O identification pins and plugs 511-9999	1 set	6 per set
I/O modules MX100PT01 MX100PT11	I/O identification pins and plugs 511-9999	1 set	6 per set
	5 A fuse MX100FS02	1	
I/O modules MX100GT13 MX100PT13	I/O connector FCN-361J040-AU(main unit)	2	6 per set
	FCN-360C40-B(cover)	2	

Contents

Foreword	
The Role of This Manual	
Configuration of the User's Manual	
Description of Symbols Used in This Manual	
Unpacking and Checking Contents	

Chapter 1 GENERAL

1-1 Features and Functions	1-1
■ Features	1-1
■ Selecting I/O modules	1-4
■ Selecting memory type	1-5
■ Processor module features	1-6
■ Internal memory configuration	1-7
■ I/O registration	1-8
1-2 System Configuration	1-10
■ Basic configuration	1-10
■ Example of package configuration	1-13
■ Loaders	1-16
1-3 List of Components	1-17
■ Model numbers of modules and related components	1-17

Chapter 2 PARTS AND FUNCTIONS OF COMPONENTS

2-1 Base	2-1
2-2 I/O Modules	2-2
■ Main unit	2-2
2-3 Processor Module	2-3
■ Main unit	2-3
■ Description of connectors	2-4
■ Front panel parts and functions	2-8

Chapter 3 INSTALLATION AND WIRING

3-1 Installation Environment	3-1
■ Installation environment	3-1
■ Precautions to be taken in installation	3-2
3-2 Installation	3-3
■ Installation dimensions	3-3
■ Mounting and removing modules	3-4
3-3 Connecting Power Supply	3-7
3-4 Ground Connection	3-9
3-5 RS-485 Connections	3-10
■ RS-485 Connections (terminal nos. 14, 15, 16 and 17)	3-10

3-6	CBL Communication Connections	3-12
	■ Connecting the MX200 using twisted pair cable	3-12
	■ Connecting the MX200 using optical fiber cable	3-14
3-7	I/O Connections	3-15
	■ I/O module connections	3-15
	■ I/O assignment and module terminals	3-16
	■ Connection to input units	3-18
	■ Input circuits	3-20
	■ Output circuits	3-24
3-8	Handling I/O Terminals	3-27
	■ Installing and removing terminals boards	3-27
	■ How to use I/O identification pins	3-28
	■ List of recommended crimp-on lugs	3-31
Chapter 4 OPERATION		
4-1	Checks Prior to Operation	4-1
	■ Checks	4-1
	■ Safety precautions	4-2
4-2	Trial Run Startup Procedures	4-4
	■ Outline	4-4
4-3	PROM Operating Procedures	4-5
	■ Writing to PROM	4-5
	■ Installing a PROM card	4-6
Chapter 5 MAINTENANCE AND INSPECTIONS		
5-1	Inspections	5-1
	■ Cautions to be heeded during maintenance inspections	5-1
	■ Inspections	5-1
	■ Periodic inspections	5-2
5-2	Replacing Parts	5-3
	■ Replacing modules	5-3
	■ Replacing the battery	5-4
	■ Replacing processor module fuse	5-6
	■ Replacing output module fuses	5-7
5-3	List of Service Parts	5-9
Chapter 6 TROUBLESHOOTING		
6-1	Error/Alarm Display and Countermeasures	6-1
6-2	Flow Charts	6-20
	■ Troubleshooting flow charts	6-20

Chapter 7 SPECIFICATIONS

7-1	Specifications	7-1
■	General specifications	7-1
■	Performance specifications	7-2
■	Process module	7-3
■	I/O module specifications	7-5
■	Input modules	7-6
■	Output modules	7-28
■	Base specifications	7-46
7-2	List of Instruction Words	7-47
7-3	Other Specifications	7-48
■	RS-232C cable	7-48
■	Lithium battery	7-49
■	Fuses	7-49
■	PROM	7-50
7-4	External Dimensions	7-51
■	Main unit	7-51
■	Place of installation	7-52
■	External dimensions of processor module	7-53
■	External dimensions of I/O module (16-point and 32-point configurations) ..	7-53
■	External dimensions of I/O module (64-point configuration)	7-54

Index

Chapter 1

GENERAL

This chapter describes the features and functions of the MX200 and provides a list of components and information on system configurations.

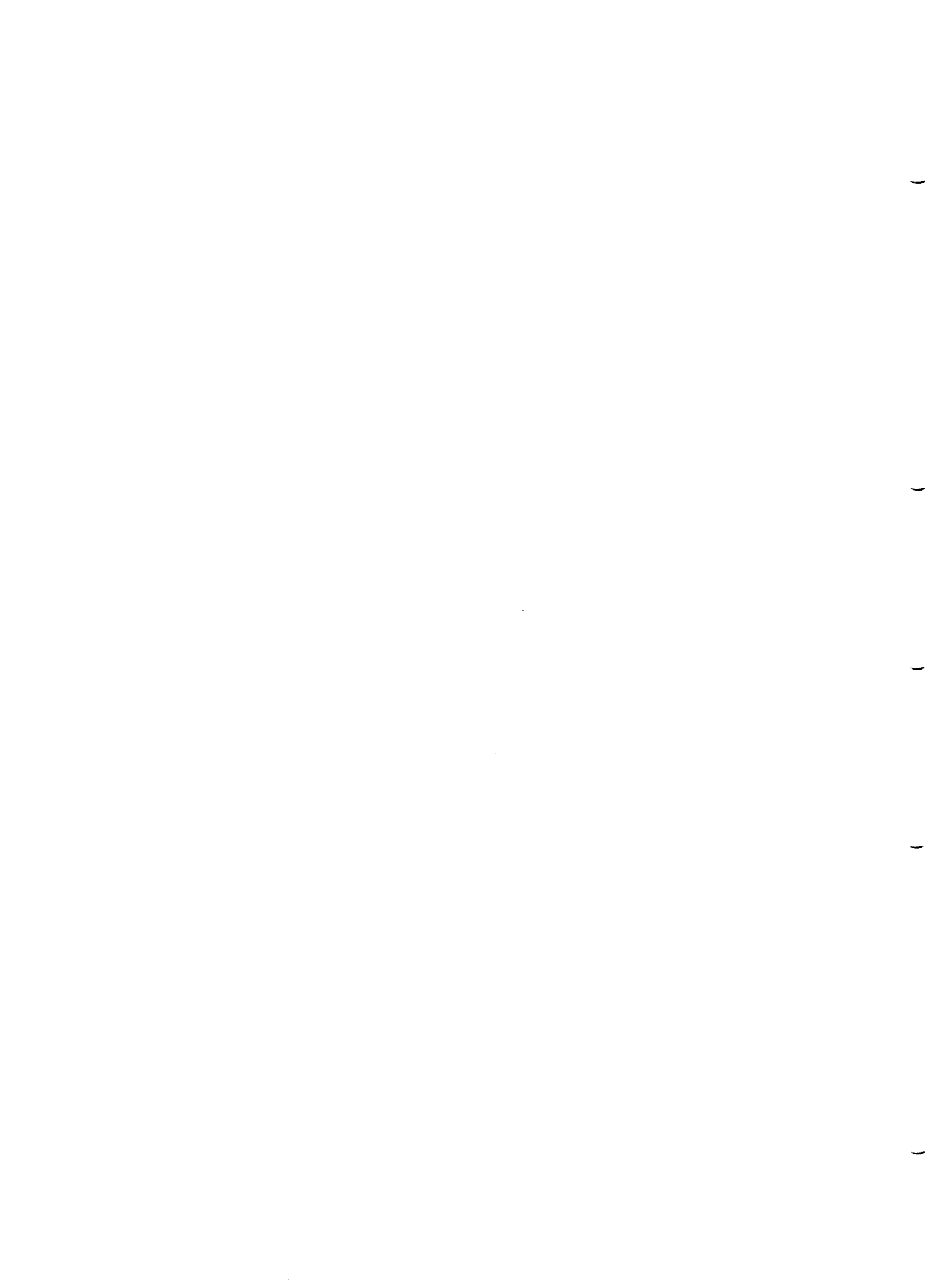

Chapter 1 GENERAL

1-1 Features and Functions

■ Features

● High-speed processing

- The use of a compiler system makes it possible to process both basic and compare instructions in $1.4\mu\text{s}$ and transfer instructions in $1.8\mu\text{s}$. It processes function instructions especially fast making it ideal for controlling intelligent machines that handle a great number of such instructions.
- The MX200 has two 8-bit CPUs, one for executing programs and the other for fetching instructions. This speeds up scanning times and reduces program execution time.

● Superior man-machine interface

- The controller can process a total of 512 I / O processing points (a maximum of 320 input and the same number of output points). In addition, it supports 160 input and 160 output operator's I / O (OP I / O) points which are used by the operation assembly and other man-machine interfaces.

Operation display lamps and operation switches are connected to the operator's I / O to make a user-friendly operation panel. The RS-485 interface for the operator's I / O minimizes the connections that have to be made since only 5 wires are needed.

- All running conditions and settings are displayed by the processor module indicators to facilitate problem diagnosis and countermeasures making the controller easy to use. The following running conditions are displayed:
 - User definition data
 - MX200 addresses
 - Error and alarm codes
 - Setup data
 - Basic display mode selection
 - Timer and counter settings and display mode
 - EEPROM write mode

● Compact configuration

The controller is a high-performance yet compact unit with a depth of a mere 102 mm thanks to the use of state-of-the-art integration technology. Four models of bases having from 2 to 8 slots make it possible to match the machine the controller is used with to set up an optimum system.

● Real-time debugging function

Debugging procedures and programming efficiency have been vastly improved since the controller can be set to stop when a preset condition is met to allow checking. An additional benefit is that debugging hardly slows down the scanning process at all.

- **Backward compatibility with MX100**

All modules including I / O modules, high-speed counters, positioning and other special modules are backward compatible with the MX100. Programs made with the MX100 can be executed on the MX200 which allows you to access the existing program library.

- **Loader**

The PC-9801 series of personal computers or compatibles can be used as loaders for the MX200. Using a personal computer as a loader improves operability and provides sophisticated functions not available to conventional dedicated loaders.

- **Powerful communication functions**

- **ASCII supported as standard**

The processor modules are provided with general-purpose ASCII communications as standard equipment which makes it simpler to write communication programs.

- **Simultaneous execution of programming and host communication.**

Host communication via a personal computer or a smart terminal makes it possible to monitor and set data simultaneous with programming and debugging.

- **OP link supported as standard**

The OP link for the operator's interface allow easy linking of OP I / O and ST100 and ST200 smart terminals.

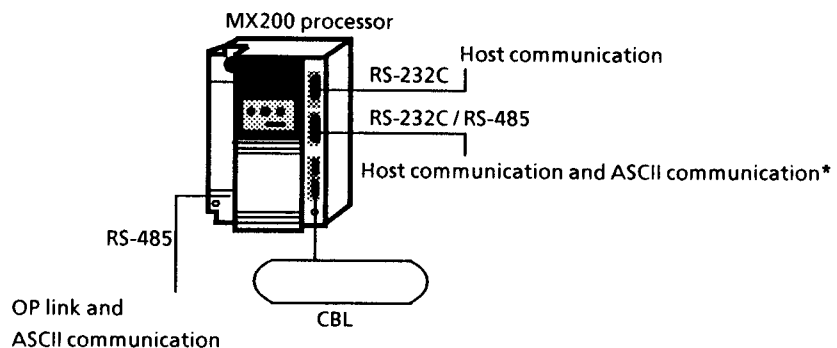

* ASCII communication is performed either via the ASCII connector or the OP I / O terminal.

- **Field network CBL (models MX200CP01T and MX200CP01P)**

The controller comes equipped with a high-speed field network which is ideal for machine internal distributed control. Machine control can thus be adapted as the system is expanded.

- **PROM**

PROMs can be used for running programs. EEPROMs or low-cost EPROMs can be added to the processor module to improve machine performance as need dictates and economy permits.

- **A complete program development environment**

Ladder programming and programming through the use of labels enable the user to adapt existing programs with a minimum of editing.

MCL (Machine Control Language), an ideal combination of C language and ladder language, is another powerful programming tool. These two tools improve programming efficiency as they provide the method that best suits a given application.

- **Library function**

A library function becomes available when a PROM is added to the processor module.

This function is a type of subroutine block that can contain special instructions required by a program and shield the structure of the program software from view.

■ Selecting I / O modules

● Selecting input modules

Both AC and DC input modules are available.

● DC input

The DC input module accepts both 12 V and 24 V.

DC and require an external DC power supply.

This module can handle inputs from low voltage and low power circuits such as push button switches and other operation switches, digital switches and other data input switches, small relays, small micro switches, optical switches and proximity switches.

● AC input

There are two models: a 100 V AC and a 200 V AC model.

Both require an external power supply.

They can accept inputs from circuits that handle comparatively high voltage and power such as limit switches and electromagnetic contactors as well as AC 2-line proximity switches.

● Selecting output modules

AC triac, DC transistor and relay output models are provided.

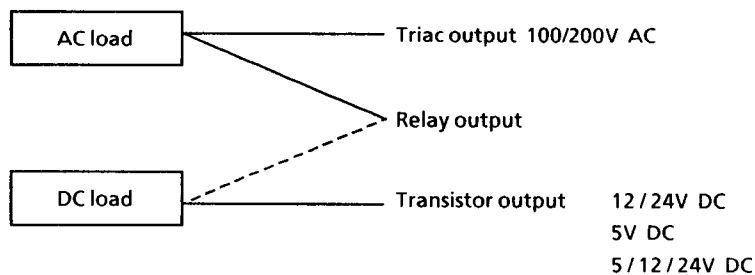

■ Selecting memory type

The user can select from the following three types of memory.

1. RAM (inside the processor module)

The processor module contains RAM memory which is battery backed up to ensure that the data is retained through a power failure. Programs created with a loader are written to RAM which means that programs can easily be edited with the loader, for example, during a trial run. Programs are first loaded in RAM also when a PROM is used.

2. EPROM

EPROM can be installed inside the cover of the processor module. Data can be written to PROM by connecting a PROM writer and a Personal Computer loader. The writing process is performed by following the instructions in the menus displayed on the personal computer screen.

3. EEPROM

An EEPROM can be installed inside the cover of the processor module. Programs created using the processor module indicator keys or programs loaded from the Personal Computer loader can be written to EEPROM. The MX200 is operated using programs stored in EEPROM. Program operation can therefore easily be changed by inserting an EEPROM card storing a different program.

Recommended types of PROM

EPROM		EEPROM	
512K	1M	1M	2M
MBM27C512-15 (Fujitsu, Ltd.) M5M27C512AK-15 (Mitsubishi Electric Corporation)	μ PD27C1001AD-15 (Nippon Electric Co., Ltd.) HN27C101AG-15 (Hitachi, Ltd.)	P28F010-150 (Intel Corporation)	P28F020-150 (Intel Corporation)

◇Note◇

Programs created with an MX100 and stored on a memory card can be downloaded to the MX200 using the following procedure.

Install the memory card in an MX100 handy loader and connect the handy loader to an MX series Personal Computer loader.

First upload the program to the Personal Computer loader. Then connect the computer to the LOAD connector (RS-232C) on the MX200 to download the program.

■ Processor module features

- Built-in power supply

The processor module has its own built-in power supply that provides the circuits with the required +5 V DC. It also powers I / O modules and other special modules.

- Twin CPU configuration

Two high-performance 16-bit CPUs share the workload and functions required by the controller are processed concurrently to yield higher processing speed.

■ Internal memory configuration

The internal memory of the controller contains a relay area, a timer and counter area, a register area and a data table area.

Data is handled in bit units in the relay area and as 16-bit words or as single bits in the register area.

Area	Name	Number	Functions	MX100(for reference)
Relay area	Input relay Output relay Input relays for OP link Output relays for OP link	X000 to X19F Y000 to Y19F X200 to X29F Y200 to Y29F	These relays are assigned to external I/O to transfer data to and from I/O. These relays are assigned to OP links to transfer data to and from OP/IO, etc.	X000 to X09F Y000 to Y09F X200 to X29F Y200 to Y29F
	Auxiliary relays	M000 to M89F		These are internal MX200 controller relays which do not output any data to the outside directly.
	Holding relay	L000 to L49F	These relays back up data during a power failure.	L000 to L49F
	Special relay	M900 to M99F	These relays process various alarms, errors and other known information.	M900 to M99F
Timer and counter area	Timer and counter	T / C000 to T / C255	The timer and the counter are triggered into action when a set time or value has been reached.	T / C000 to T / C199
Register area	Word input register Word output register	R0500 to R0519 R0600 to R0619	These registers are assigned to special function modules and process data in bit units.	R500 to R519 R600 to R619
	Special register	R0900 to R0999		These registers are provided for various self-diagnostic data, error information and other known information. They process data in bit units.
	Data registers	R0000 to R0499 R1000 to R4999	This data area is used for function instructions and processes data in bit units.	R000 to R499
	Link registers	P0000 to P3799 P3800 to P3999	This is a PC link area. This is a PC link setting area which processes data in bit units.	None
Data table area	Data table	#0 to 9998	This program area uses RTBL instructions to read data and WTBL instructions to write data.	#0 to 5999

◇Notes◇

- Output relays not assigned to I/O can be used as auxiliary relays.
- Input and output relays not assigned to I/O can be used as data registers.

■ I/O registration

● General-purpose I/O

I/Os are registered by using a Personal Computer loader or a handy loader. The MX200 processor module automatically reads the data (stored data) in I/O modules in the I/O slots when the power is turned on or when the reset switch is pressed. Assignment is based on two factors, how close an I/O module is to the processor module (location) and when it was installed in the base (timing). Inputs start from X000 and outputs from Y000. Assignments are automatically left justified if there are any unoccupied slots.

Processor module	32 input points X000 X01F	16 output points Y000 Y00F	Unoccupied	16 input points X020 X02F	32 input points Y010 Y02F	
------------------	---------------------------------	----------------------------------	------------	---------------------------------	---------------------------------	--

I/Os exceeding 512 points (a maximum of 320 input points and 320 output points) are ignored. When I/Os are registered by the loader, their data is registered as reference data, and a difference between stored data and the reference data is indicated as an error. If not registered, the stored data is employed as reference data, each time power is turned on. Refer to the MX Series user manual, Personal Computer loader CP-UM-1602E for details.

● Operator's I/O

The I/O for the OP link are registered by setting the number of words required by the number I/O points with the loader. Inputs are assigned from X200, while outputs are assigned from Y200. Note that inputs/outputs exceeding 160 points are ignored.

An alarm is displayed in the following cases.

- No OP I/O response at startup.
- Stored OP I/O data differs from registered data.
- No OP I/O response during operation.

Unless the OP I/Os are assigned with the loader they will not function even if they are connected.

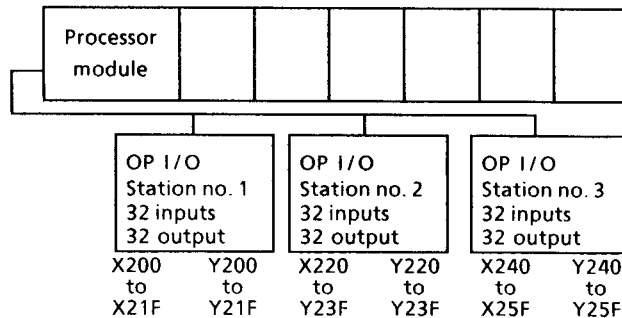

◇Note◇

The processor module does not automatically read the OP I/O data when the OP link I/O is not registered.

● Special Function Modules

Like general-purpose I / Os, these modules are assigned either by a Personal Computer loader or handy loader. The MX200 special function modules are assigned to I / O registers in word units (16 bits). Inputs are assigned to R500-R519 and outputs are assigned to R600 to R619 starting from those closest to the processor module. Assignment starts automatically when the power is turned on or when the reset switch is pressed. Special function modules may be mounted in any I / O slot. After assignment, a missing I / O module is detected by comparing the I / O module data with registered I / O module data (if I / O assignments are registered in the Personal Computer loader) or with the data stored in the processor when the power was turned on or when the RESET switch was pressed.

Processor module		Special function Input 4 words Output 2 words		Special function Input 2 words Output 4 words		
------------------	--	---	--	---	--	--

Input	Output	Input	Output
R0500	R0600	R0504	R0602
to	to	to	to
R0503	R0601	R0505	R0605

See the user's is manual supplied with the special module for details. Special I / O modules denote analog input modules and special function modules.

1-2 System Configuration

■ Basic configuration

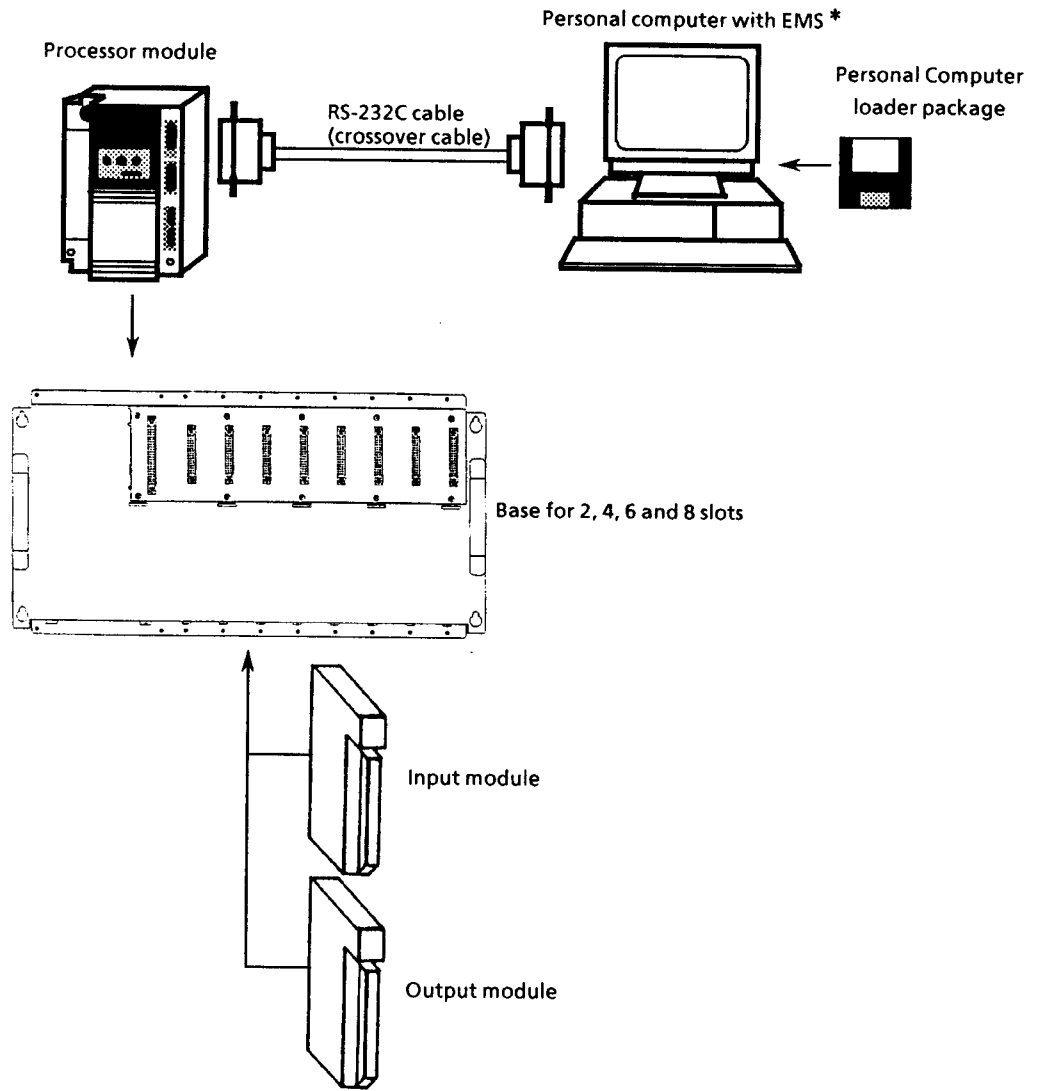

* EMS(Expanded Memory Specification)

The following sections describe system configuration.

- Base

Four different bases having 2, 4, 6 or 8 slots are available for the MX200. This allows the user to set up an optimally configured system as he can select the base with the number of slots that meets his requirements for modules, I/O points and other application needs.

- Processor module

The processor module has a built-in power supply which powers the I/O and special function modules.

There are a total of 512 input and output points (maximum 320 input and a maximum of 320 output points) and a total of 160 operator's I/O (OP I/O) points (160 inputs and 160 outputs) while the program size is 31K.

In addition to processor module RAM, a PROM can also be used as main memory.

- I/O modules

There are a total of 11 input modules:

Two 100V AC, two 200V AC and seven 12/24V DC.

There are 8 output modules:

Two relay output modules, two 100/200V AC triac output modules, three 12/24V DC modules and one 5V DC module.

- Special function modules

There are a great number of special function modules such as high-speed counter modules, positioning modules, analog input modules and analog output modules to meet the needs of a specific application.

● Program memory capacity

As shown in the table below, program memory capacity is displayed in bit units or byte units depending on the device.

Device	Model	Memory capacity	Program size		Remarks
			Ladder	Data table	
RAM (inside processor module)		64K	31K	20K	Instruction words use between 2 to 13 bytes per instruction. Programs where the sum of all instructions is 31K can be stored in RAM. 1K is used for internal processing.
PROM EPROM	MBM27C512-15(Fujitsu, Ltd.) M5M27C512AK-15(Mitsubishi Electric Corporation)	512K 1 Mbits	31K	20K	PROM capacity is indicated in bit units. 512 kbits is 64K. However, the maximum program size when a 1 Mbit PROM is used is still 32K.
EEPROM	μPD27C1001AD-15(Nippon Electric Co., Ltd.) HN27C101AG-15(Hitachi, Ltd.) P28F010-150(Intel Corporation) P28F020-150(Intel Corporation)	1 Mbits 2 Mbits			

◇Note◇

PROM cannot store programs that exceed the program capacity of the processor module (31K).

■ Example of package configuration

● Basic Configuration

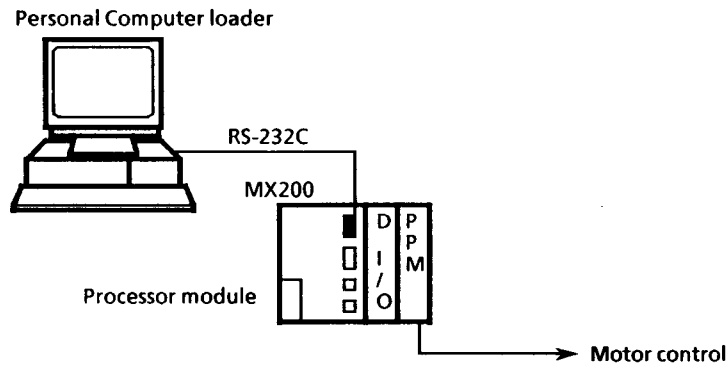

This configuration is used for sequence control, positioning control and data processing using analog input and output.

● Host communication and data link communication

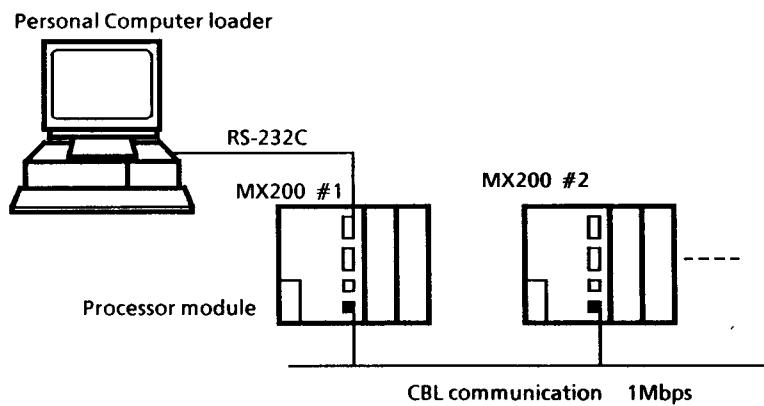

This configuration is used to connect the MX200 to several CBLs (Controller Based Links) to allow PC link and mail communications between the connected units.

Since programs in MX200 #2 can be edited via MX200 #1, the system allows for expansion. Select model MX200CP01T or model MX200C01P for these type of systems.

● Configuration comprising indicator

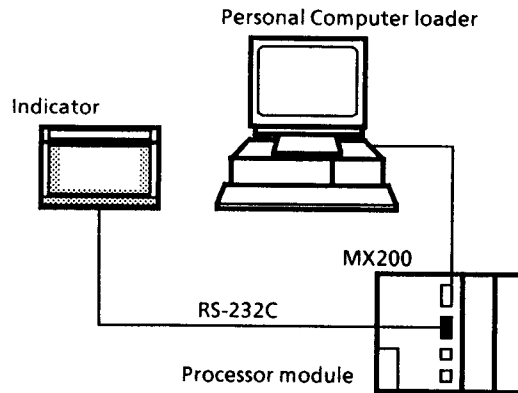

Monitor and data settings can be made through the use of an indicator (Yamatake - Honeywell ST-series) during programming and debugging. When the ST-series of indicators are used with the MX200 during host communication, operation can be performed without a program.

● Connection configuration involving temperature controllers

Ladder program communication is possible when the OP link function of the processor module is switched and temperature controllers are multidrop connected using RS-485 ASCII communication.

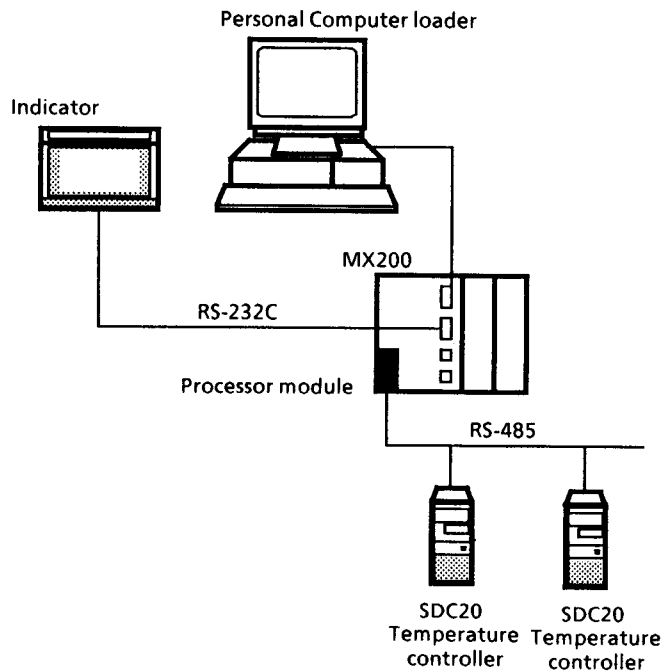

● OP link connection configuration

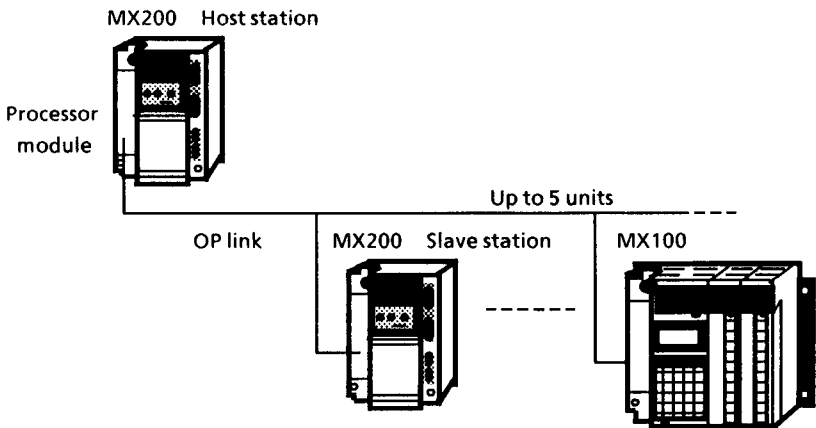

Thirty-two MX200 OP link input/output relays (X200 to X29F and Y200 to Y29F) for host station MX200 and thirty-two MX200 OP link input / output relays (X200 to X21F and Y200 to Y21F) for slave station MX200 can be shared. A total of 5 slave stations can be connected. Operator's I/O (OP I/O) can be connected to the OP link.

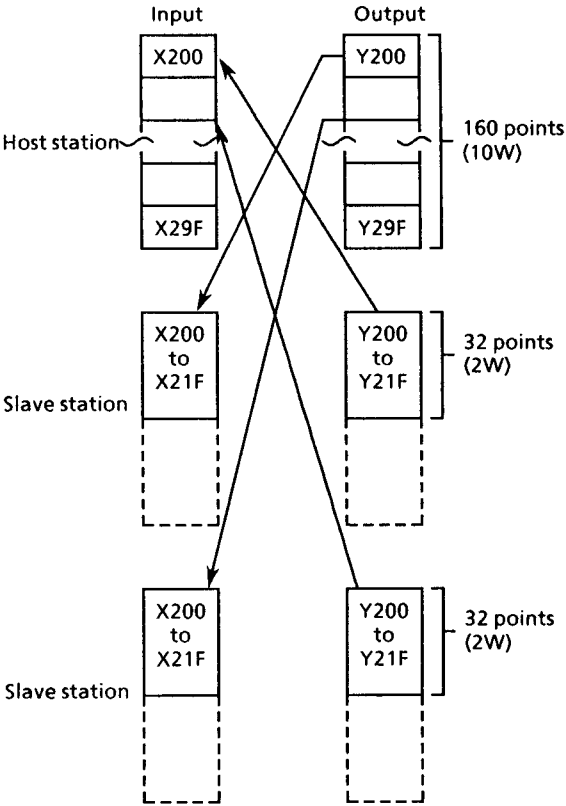

■ Loaders

A Personal Computer loader, a general-purpose personal computer, can be used with the MX200 for creating, debugging, loading and saving programs.

● Personal Computer loaders

A Personal Computer loader comprises a software package on floppy disks and a IBM PC personal computer or compatible machine.

The software package is available on 3.5 inch floppy disks.

◇Note◇

A personal computer used as a Personal Computer loader has to meet the following requirements

- IBM PC or compatible machine
- EMS memory with a minimum of 528K
- MS-DOS 3.3

Refer to the MX-series user's manual Personal Computer loader CP-UM-1602E for further information on personal computer models, detailed specifications and handling.

1-3 List of Components

■ Model numbers of modules and related components

The table below lists modules and peripheral equipment that can be used with the MX200 controller.

● Module model numbers

Product	Model No.	Description
Bases	MX100BS01 MX100BS02 MX100BS03 MX100BS04	Base with 2 I/O slots Base with 4 I/O slots Base with 6 I/O slots Base with 8 I/O slots
Processor modules	MX200CP01 MX200CP01T MX200CP01P	Program size 31K Program size 31K, electric CBL communication connectors Program size 31K, optical CBL communication connectors
Input modules	MX100GT01 MX100GT02 MX100GT31 MX100GT32 MX100GT11 MX100GT12 MX100GT13 MX100GT14 MX100GT15 MX100GT75 MX100GT78	16 points 100V AC delay 35 ms 32 points 100V AC delay 35 ms 16 points 200V AC delay 35 ms 24 points 200V AC delay 35 ms 16 points 12/24V DC delay 15 ms 32 points 12/24V DC delay 15 ms 64 points 12/24V DC delay 1.5 ms, bidirectional 16 points 12/24V DC delay 1.5 ms 32 points 12/24V DC delay 1.5 ms 32 points 12/24V DC delay 1.5 ms, bidirectional 32 points 12/24V DC delay 0.5 ms, bidirectional
Output modules	MX100PT01 MX100PT11 MX100PT12 MX100PT13 MX100PT42 MX100PT72 MX100PT21 MX100PT22	16 points 100/200V DC Triac output 16 points 12/24V DC Transistor output 32 points 12/24V DC Transistor output 64 points 5/12/24V DC Transistor output 32 points 5V DC Transistor output 32 points 12/24V DC Transistor output (PNP) 16 points Relay output 32 points Relay output
Input and output module	MX100GP12	16 input points and 16 output points 12/24V DC
Analog input modules	MX100GT53 MX100GT56	4-channel analog input 0 to 5V/0 to 10V/0 to 20mA 4-channel analog input -5V to 5V/0 to 10V
Analog output module	MX100PT52	2-channel analog output -10V to 10V/0 to 10V/0 to 20mA
Operator's I/O module	MX100MP01	Static, 32 input points, 32 output points, case provided
Special modules	MX100CT61 MX100CM41 MX100CM61 MX100NC11 MX100NC12	High-speed counter RS-232C/RS-485 converter Serial communication module Positioning module pulse output, 1-axis Positioning module pulse output, 2-axis

● Model numbers of related components

Product	Model No.	Description
Personal Computer loader package	MX200SW01 MX200SW02	3.5 inch floppy disk software package to be used with a IBM PC
RS- 232C cables	CBL-RS232T02 CBL-RS232T08	2 m / 8 m cable for connecting to Personal Computer loader
Lithium battery	MX100BT01	Battery for backing up processor module memory
Fuse	MX100FS01 MX100FS02	2 A fuse for processor module 5 A fuse for output module
I/O terminal boards	511-9947 511-9948	16 points 32 points
I/O terminal covers	MX100ST31 MX100ST32	16 points I/O terminal covers (10 covers per set) 32 points
I/O identification pins and plugs	511-9999	

Chapter 2

PARTS AND FUNCTIONS OF COMPONENTS

This chapter describes the parts and functions of the MX200 base, processor modules and I/O modules.

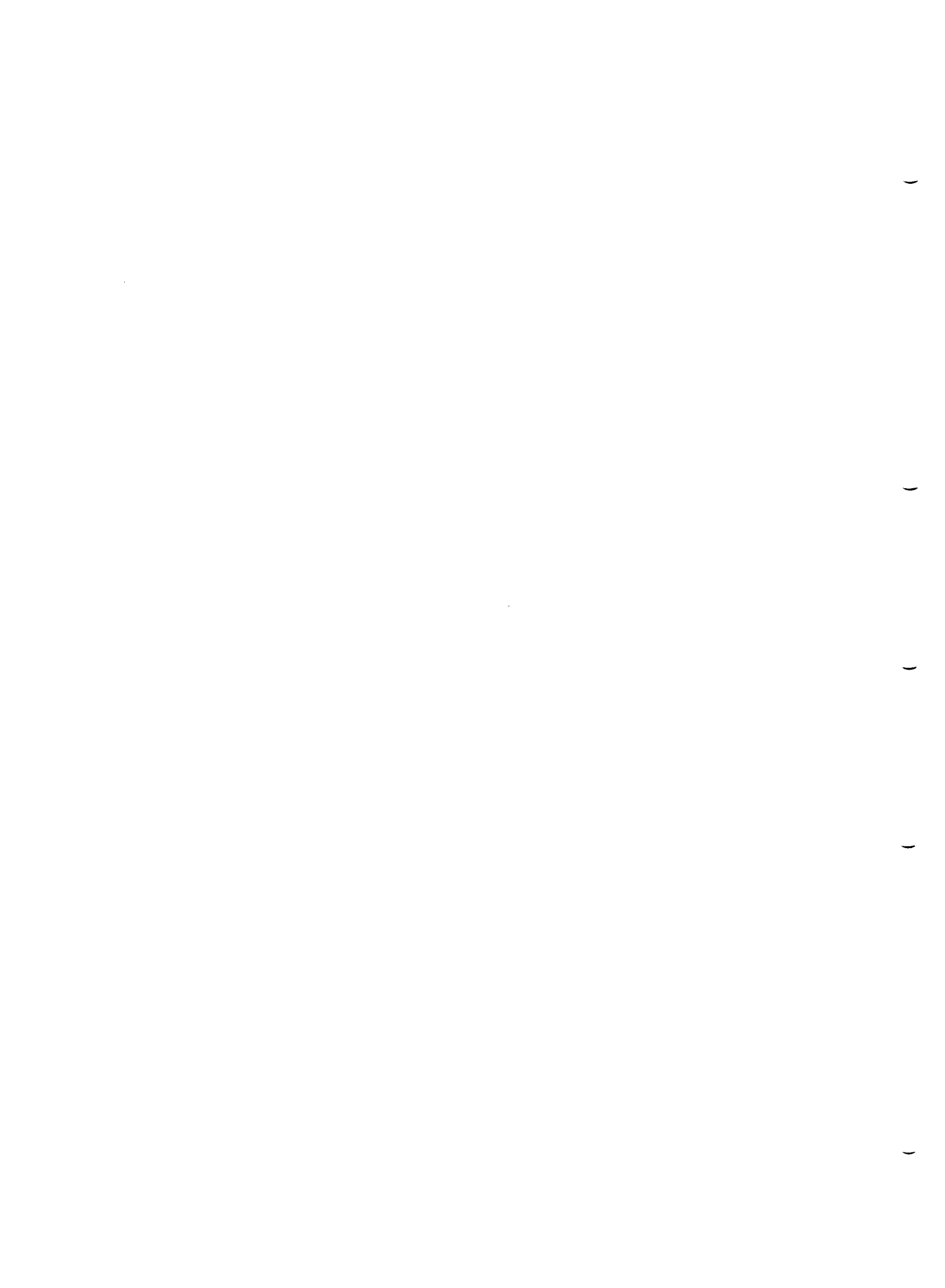

Chapter 2 PARTS AND FUNCTIONS OF COMPONENTS

2-1 Base

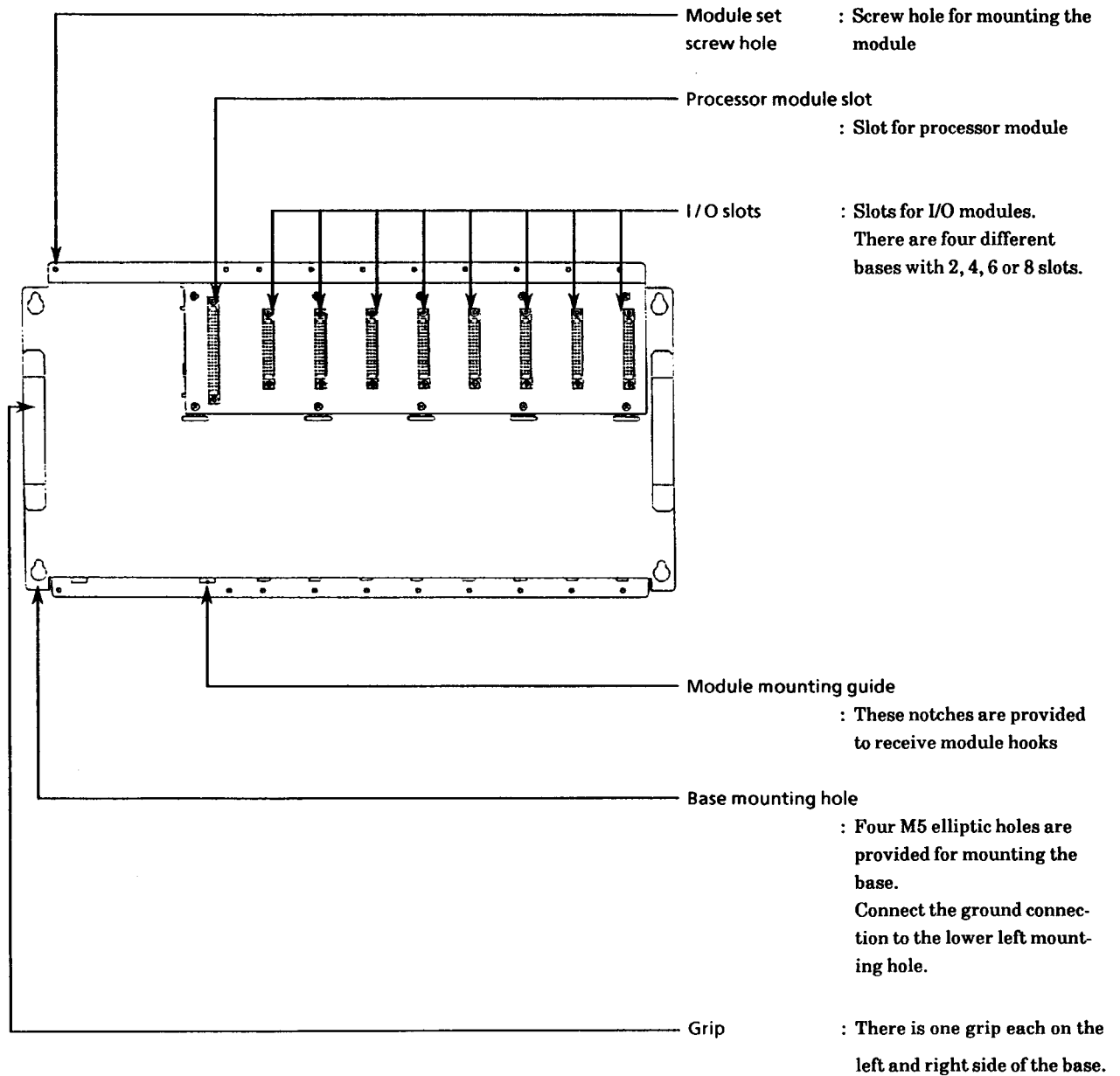

2-2 I/O Modules

■ Main unit

● 16 and 32 point modules

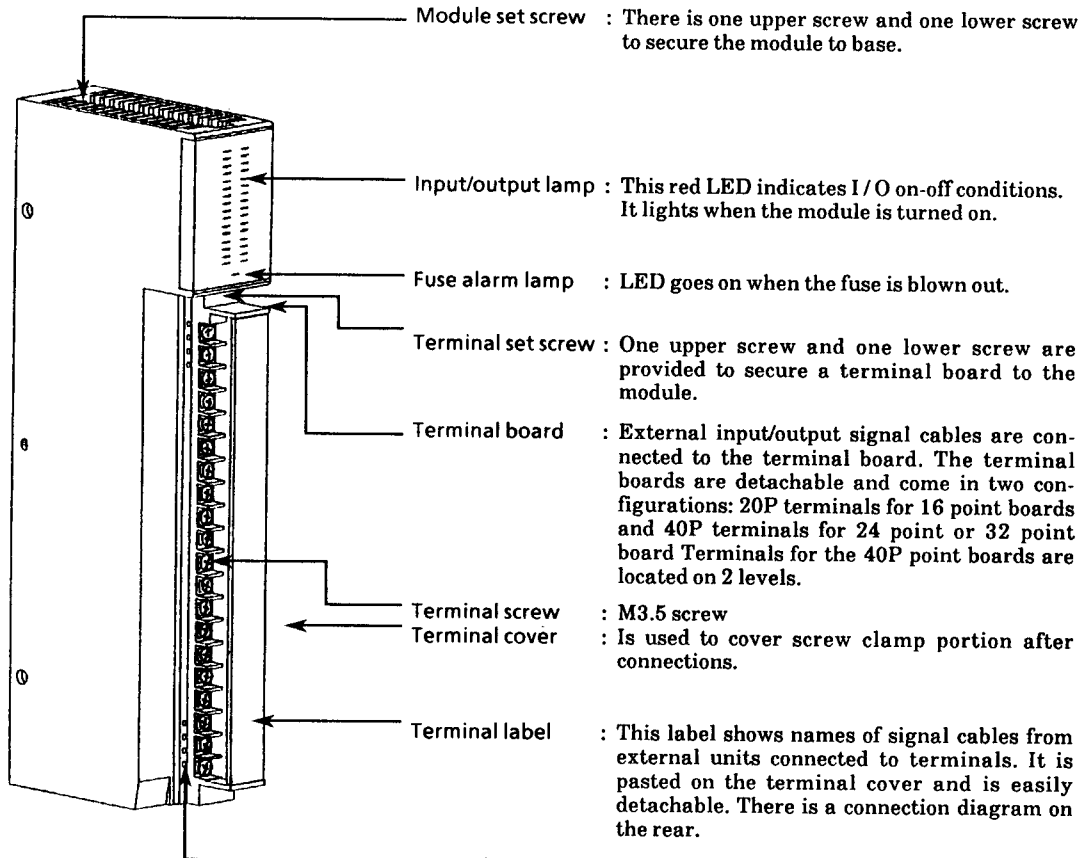

● 64-point module

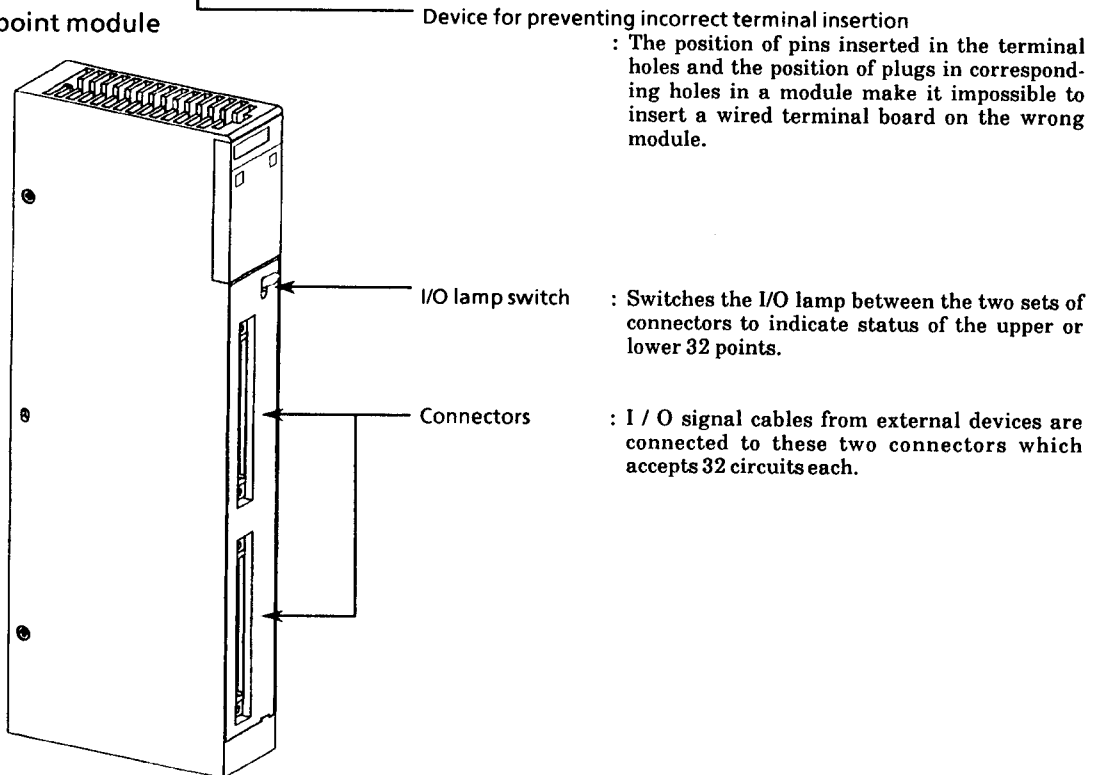

2-3 Processor Module

■ Main unit

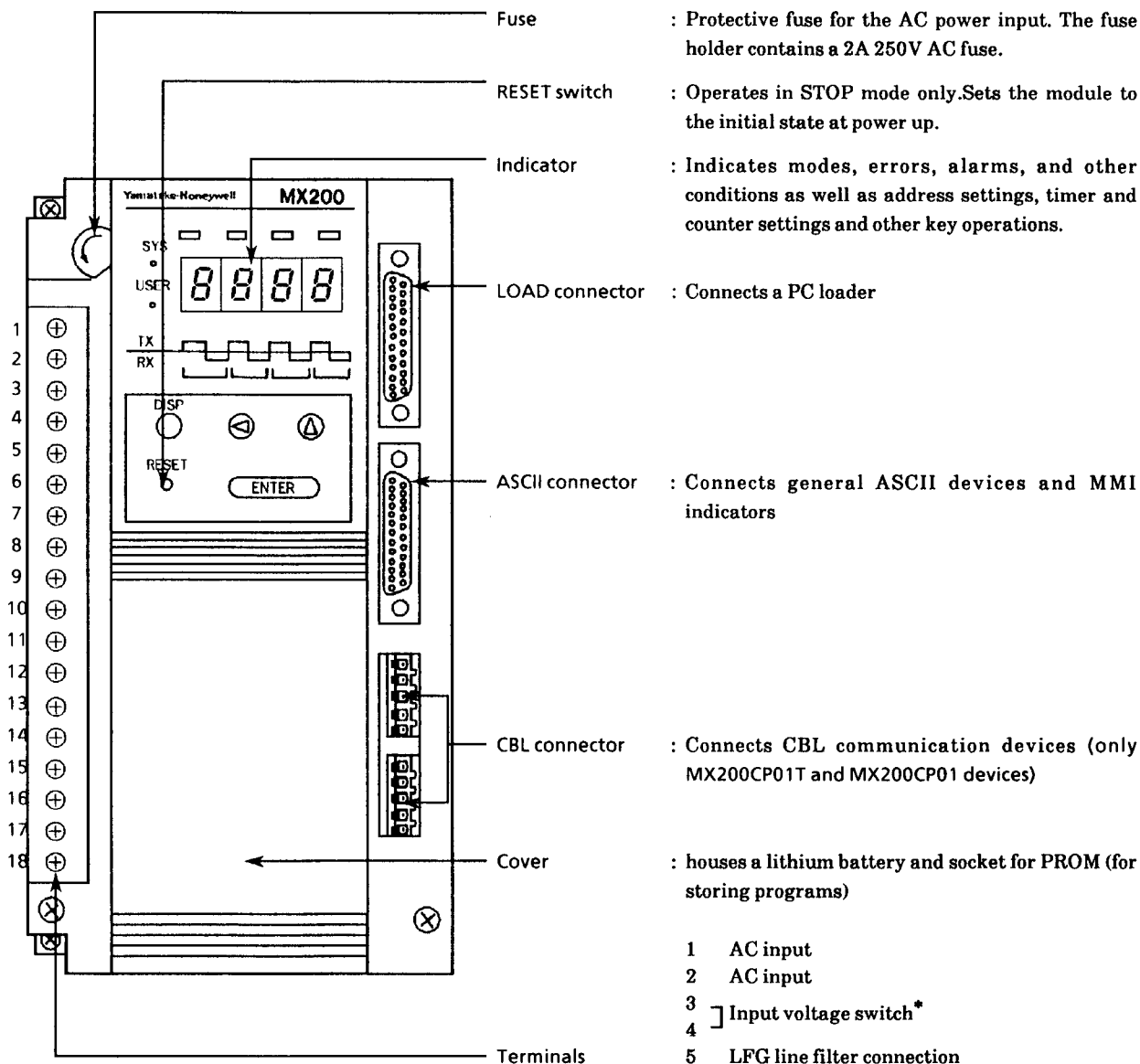

The figure shows the terminals as they appear when the terminal cover is removed.

- Fuse** : Protective fuse for the AC power input. The fuse holder contains a 2A 250V AC fuse.
 - RESET switch** : Operates in STOP mode only. Sets the module to the initial state at power up.
 - Indicator** : Indicates modes, errors, alarms, and other conditions as well as address settings, timer and counter settings and other key operations.
 - LOAD connector** : Connects a PC loader
 - ASCII connector** : Connects general ASCII devices and MMI indicators
 - CBL connector** : Connects CBL communication devices (only MX200CP01T and MX200CP01 devices)
 - Cover** : houses a lithium battery and socket for PROM (for storing programs)
 - Terminals**
 - 1 AC input
 - 2 AC input
 - 3 } Input voltage switch*
 - 4 }
 - 5 LFG line filter connection
 - 6 FG frame ground
 - 7 } RUN input (contact input)
 - 8 } STOP input (contact input)
 - 9 }
 - 10 } Error output
 - 11 } (These contact outputs go off when an error occurs)
 - 12 } Alarm output
 - 13 } (These contact outputs go on when an alarm occurs)
 - 14 SDA RS-485 transfer data
 - 15 SDB
 - 16 RDA RS-485 reception data
 - 17 RDB
 - 18 SG signal ground
- * 100 V terminals when 3-4 are closed
200 V terminals (set at time of shipment) when 3-4 are open

■ Description of connectors

The RS-232C connector is used for making connections to loaders, personal computers or ASCII devices. The RS-232C connector of the processor module is inside a protective cover which has to be removed to access it. The CBL communication connector is used for handling CBL communications. Processor modules come either with electric or optical CBL communication connectors depending on the model number.

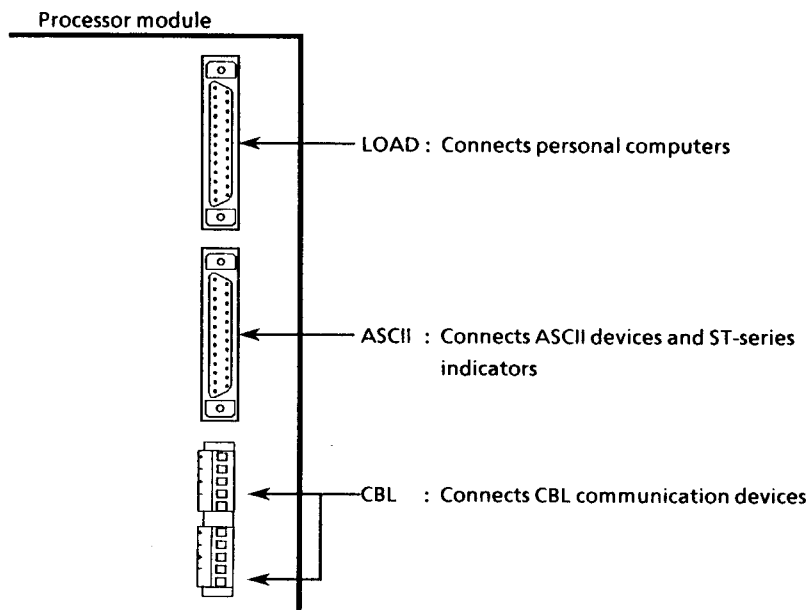

● LOAD connector

This connector is used to connect personal computers using an RS-232C crossover cable.

(Cable model no : CBL-RS232T02 cable : a 2 meter cable
 CBL-RS232T08 cable : an 8 meter cable)

◇Note◇

The LOAD connector on MX200 controllers with CBL communication function (MX200CP01T and MX200CP01P) cannot be used for multidrop connections via an external converter.

● ASCII connector

This connector is used to connect barcode readers and other general purpose ASCII devices and Yamatake - Honeywell's ST-series (Smart Terminal series) of indicators.

Communication without the use of a program is possible when this connector is used between a host computer and the ST-series of indicators.

● CBL connector

This connector is used to connect CBL communication devices.

- MX200CP01T Electric model
Use twisted pair cable to make connections.
- MX200CP01P Optical model
Use a special optical connector to make connections.

● Connector pin arrangement

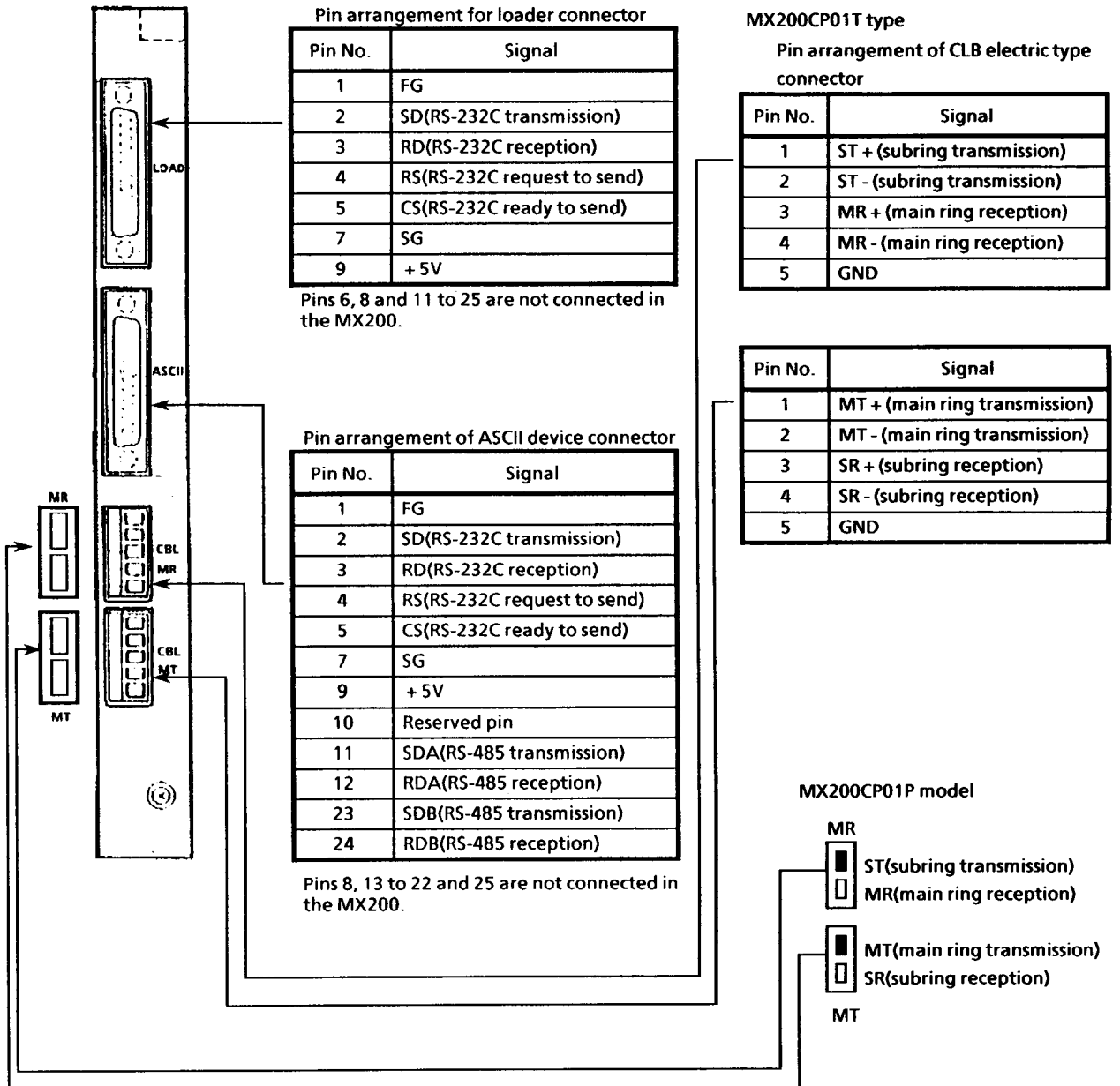

● Notes on using the RUN input and STOP input

When the RUN input is closed (turned on), the controller is set to the RUN mode as soon as it is powered up.

This is called auto start. If the STOP input is closed (turned on) under this condition, the controller is set to the STOP mode and will stay in this mode until the RUN input is closed (turned on) again. The STOP mode can thus not be canceled by opening the STOP input later.

If the RUN input or STOP input is momentarily closed (turned on), the controller is set to the mode where an input was made.

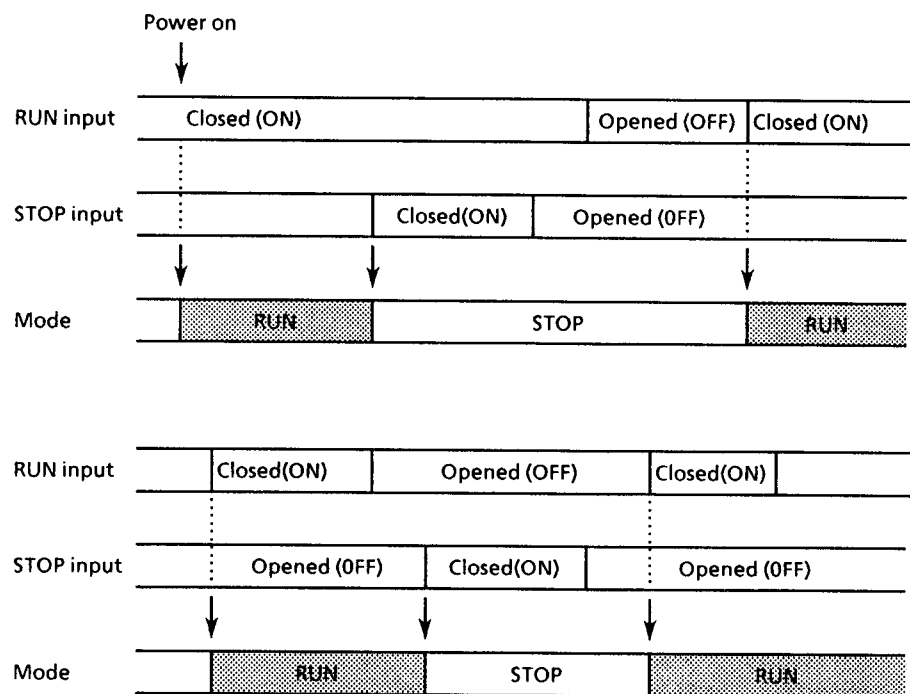

◇Notes◇

- When the STOP input is closed, the STOP mode has priority, and the controller stays in the STOP mode making it impossible to change modes even by closing the RUN input.
- The controller cannot be set to the RUN mode during the compile operation at power up by closing the RUN input. The controller will be set to the RUN mode after the compile operation completes.
- If the RUN input is kept in the closed (auto start) position, the controller will stay in that mode even if a momentary recovery is attempted by resetting it to 0 (restart) using the processor module keys.
- RUN input and STOP input should be set to closed (ON) for 20 ms or longer.

● STATUS changes

The processor modes are related as shown below.

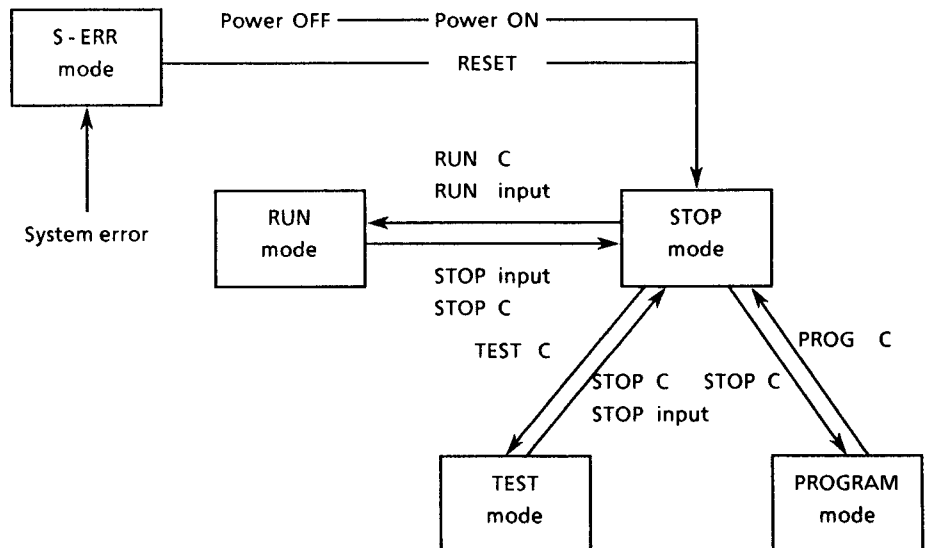

◇ Note ◇

The RUN input and STOP input are contact inputs from the processor module terminal while RUN C, STOP C and PROG C are mode selection commands input from the loader.

The RUN, TEST and PROGRAM modes are accessed via the STOP mode. In STOP mode the output is set to OFF.

Since the MX200 controller uses a compile system, there is a 1 to 3 second wait to allow for the compile operation performed when the following events occur.

- ① When the power is turned on or the RESET button is pressed.
- ② When the PROGRAM mode is exited.
- ③ When the TEST mode is exited.

The RUN and STOP input states of the processor module restrict mode changes.



Refer to the Machine Controller MX series user's manual Personal Computer Loader CP-UM-1602E.

■ Front panel parts and functions

The front panel of the MX200 has 14 LEDs, four 7-segment (4 digit) LEDs and keys to make settings and change or display statuses.

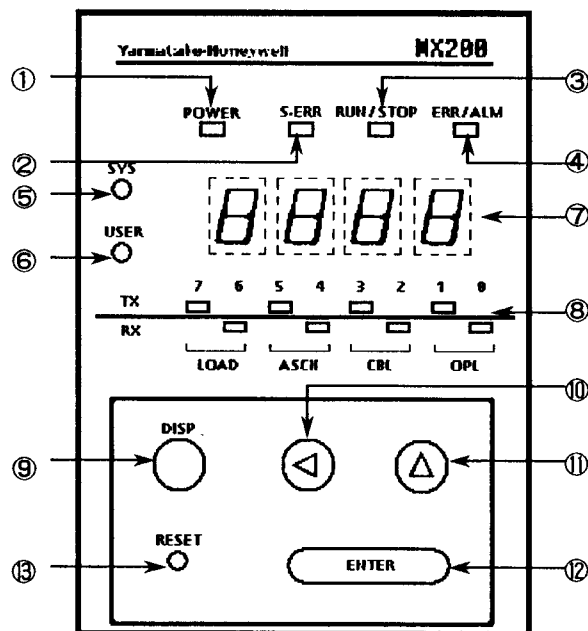
To facilitate operation, the [DISP] key, [ENTER] key and the  cursor control key produce an audible click. A quickly repeated sound is used to alert the user to the fact that he has pressed an invalid key.



- ① POWER LED : Goes on when the power is turned on and goes off when the power is turned off.
- ② S-ERR LED : Goes on to indicate a system error, is otherwise off
- ③ RUN / STOP LED : On in RUN mode, off in STOP mode and flashes in TEST mode.
- ④ ERR / ALM LED : Flashes when an error occurs, on when an alarm is output, flashes when both an error and an alarm are generated and off when no error or alarm has occurred.
- ⑤ SYS LED : On in system mode, off in user mode and flashes during menu selection
- ⑥ USER LED : On in user mode, off in system mode
- ⑦ Indicator : 7-segment, 4-digit LED displays error codes and data
- ⑧ 8-bit data indicator: Displays send and reception status of data for the LOAD connector (RS-232C load connector), ASCII connector (RS-232C or RS-485 ASCII communication connectors), CBL communication and OP link communication.
- ⑨ [DISP] : Returns the indicator to the previous display mode irrespective of current mode (data display or data change).
- ⑩  : Moves cursor to digit which is to be replaced or between menu items.
- ⑪  : Increments or decrements numeric values (for example, 0 -> 1 -> 2 ... 9 -> 0) and moves the cursor.
- ⑫ [ENTER] : Enters set numeric value or menu choice.
- ⑬ [RESET] : Performs a hard reset of the MX200.

MEMO

● Description of display modes

○ / □ = On ● / ■ = Off ○ / □ = Flashes

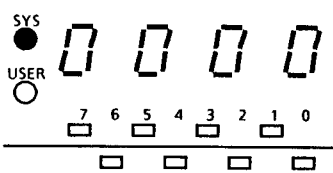
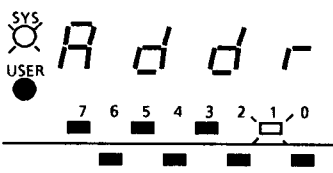
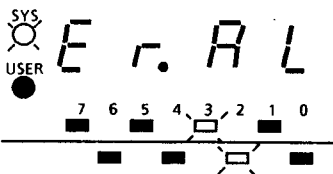
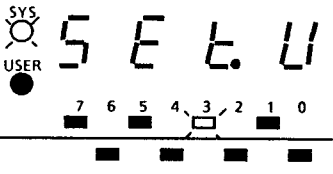
Mode/Status flow	Display status of 7-segment LED and Bit LED indicators	Submode items ENTER section
<p>Power on</p> <p>Initial display</p> <p>[DISP] [DISP]</p>		
<p>MX address display /setting mode</p> <p>ENTER</p>		<p>ENTER</p> <p>This is not a submode. The MX address display/setting items are now directly displayed.</p>
<p>Error alarm display mode</p> <p>ENTER</p>		<p>ENTER</p> <p>Error code display</p> <p>Alarm code display</p>
<p>Communication setup mode</p> <p>ENTER</p>		<p>ENTER</p> <p>Changing processor module mode(RUN/STOP/TEST/PROGRAM)</p> <p>OPL connector communication setup</p> <p>CBL connector communication setup</p> <p>ASCII connector communication setup</p> <p>LOAD connector communication setup</p>

Description of functions, display and settings	Initial values when shipped	Remarks
<p>① Displays the values set in the initial display setting mode. 7-segment LED indicator indicates values in register R0992 8-bit LEDs indicates values of low-order bytes in register R0993</p> <p>② The initial display setting (registration) is specified by register R0991 value.</p>	<p>R0991 = 0000 R0992 = 0000 R0993 = 00FF</p>	
<p>① Sets or changes the MX address.</p>	<p>Address = 1</p>	<p>Range of settings/changes: 1~63、7FH</p>
<p>① Displays error codes(Er□□) or alarm codes(AL□□).</p>		<p>· See Chapter 6, "Troubleshooting."</p>
<p>① Processor module mode Switches between modes(RUN / STOP / TEST / PROGRAM)</p> <p>② Determines communication setup (settings). OPL connector : Selects OPL address, Baud rate, communication format, slave or host setting and connector usage.</p> <p>CBL connector : Selects a reception group for one destination communication (no response) command, PC link status, PC link communication destination group, PC link reception group, PC link reception data, monitoring time and CBL communication format.</p> <p>ASCII connector : Selects Baud rate, data length, parity bit, stop bit, connector usage, connector function selection, full duplex or half duplex, RTS control off or on, RS-232C and RS-485.</p> <p>LOAD connector: Select MX address setting, Baud rate, communication format, operation at momentary recovery, RS-232C and RS-485.</p>	<p>Mode = STOP</p> <p>See page 2-18, "Communication setup mode."</p>	<p>· The communication setup mode is started only when the processor module is in the STOP mode.</p> <p>· Only models MX200CP01T and MX200CP01P can be used with the CBL connector.</p>

○ / □ = On ● / ■ = Off ◊ / ◻ = Flashes

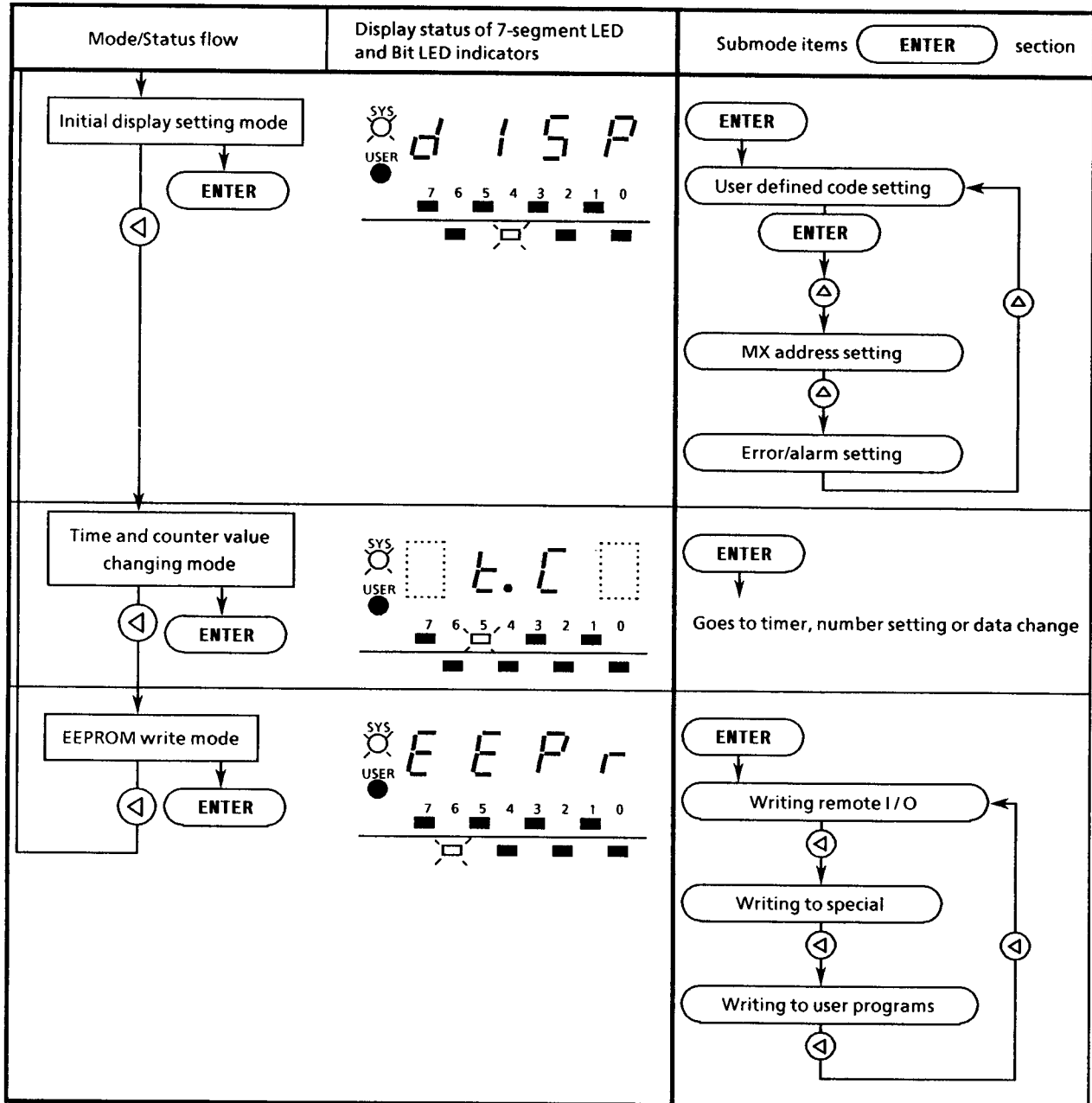

Description of functions, display and settings	Initial values when shipped	Remarks
<p>① One of the following settings can be set and is called up when the controller is powered up or reset.</p> <ul style="list-style-type: none"> ● User code display: Register R0991 is set to 0 or register R0991 is set to 3 or more. ● MX address display Register R0991 is set to 1 ● Error/alarm display Register R0991 is set to 2 	User code setting	If the error/alarm display is set, it is not displayed when modes are changed. This is also true for the MX address display.
<p>① Changes timer or counter numbers or data values that are used in ladder programming.</p>	—	
<p>① Writes the following data to EEPROM</p> <ul style="list-style-type: none"> ● Remote I/O (slave station) data during CBL communication ● Special register data in MX ● User programs 	—	<ul style="list-style-type: none"> · Remote I/O assignments can be made only with MX models MX200CP01T and MX200CP01P. · When a user program is to be written, install an EEPROM in the main unit of the processor module.

● MX address display/setting mode

This mode is used to set MX200 addresses.

- Range of settings 1 (initial setting) - 63
- Make sure that there are no duplicate addresses when an MX200 with CBL communication function (models MX200CP01T or MX200CP01P) is used.

● Operation procedures

The following shows how to set an address of 13.

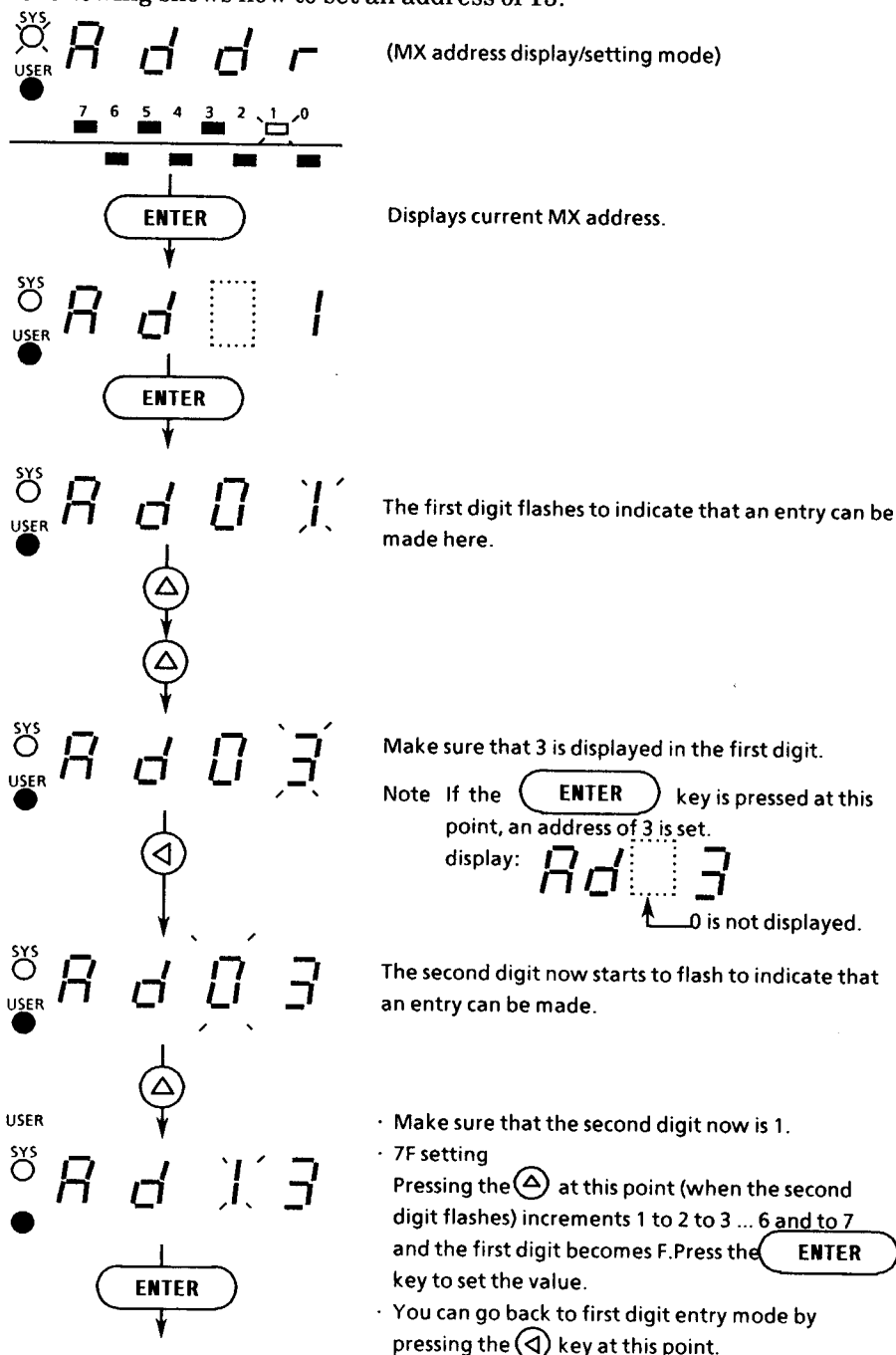

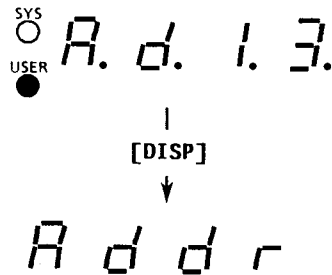

An MX address of 13 has now been set. The dots in the 7-segment LED light to indicate that the current address and the displayed address differ. The write operation to the EEPROM is terminated and when the MX200 controller is powered up again the dots will be off.

◇Tips◇

- This mode is used to display and set the values of register R0950 in the MX200.
- The R0950 value is automatically copied to register R0959 when the MX controller is powered up and actual operation uses R0959 values. Thus although the display changes when the R0950 is rewritten in this mode, the actual address used in operation does not change.
- When new values are to be used in operation, do as follows. Exit this mode, go to the EEPROM write mode and write the new values to one of its special registers. When the MX controller is powered up next time, the displayed address will be valid.

◇Note◇

When an MX200 model with CBL communication function is powered up without making a CBL connection, the CBL communication alarm (AL60) and the CBL communication line trouble (AL65) will be generated. When the CBL function on an MX200 model with CBL communication function is not to be used, cancel the alarms using one of the following two procedures.

Procedure 1 : Set the MX200 address to 7F.

Procedure 2 : Connect the MX200 local station CBL connectors MR and MT to each other.

Below the 8-bit LEDs show additional information for the following error codes.

Error code 1

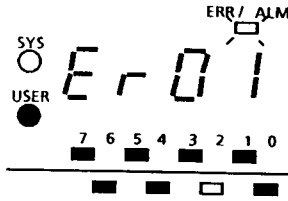

I/O bus error
The bit LED (0-7) that corresponds to the slot position (1-8) where an error occurred goes on.
In the example, the error occurred in slot 3.

Error code 2

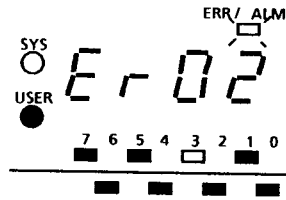

I/O reference error
The bit LED (0-7) that corresponds to the slot position (1-8) where an error occurred goes on.
In the example, the error occurred in slot 4.

Error code 3

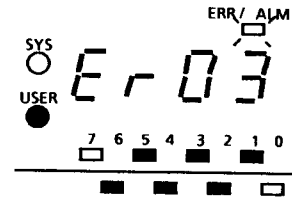

I/O module error
The bit LED (0-7) that corresponds to the slot position (1-8) where an error occurred goes on.
In the example, the error occurred in slots 1 and 8.

Below the 8-bit LEDs show additional information for the following error codes.

Alarm code 3

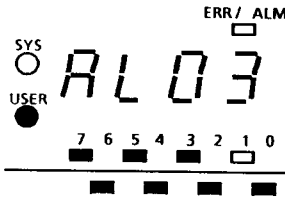

Fuse blown alarm
The bit LED (0-7) that corresponds to the slot position (1-8) which caused the alarm goes on.
In the example, the error occurred in slot 2.

Alarm code 21

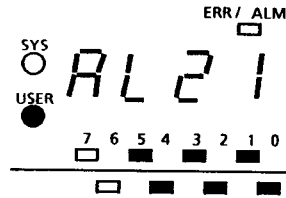

OP I/O communication alarm
The bit LED (0-7) that corresponds to the OP link station number (1-8) which caused the communication error goes on.
In the example, addresses 7 and 8 are abnormal.

Alarm code 22

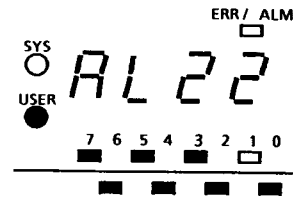

OP I/O communication alarm
The bit LED (0-7) that corresponds to the OP link station number (9-15) which caused the communication error goes on.
In the example, address 10 is abnormal.

Alarm code = 23

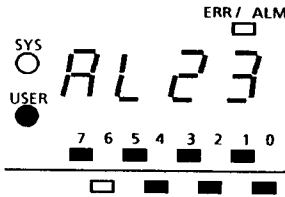

OP I/O reference alarm
The bit LED (0-7) that corresponds to the OP link station number (1-8) which caused the reference alarm goes on.
In the example, address 7 is abnormal.

Alarm code = 24

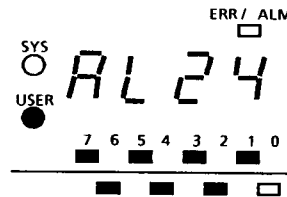

OP I/O reference alarm
The bit LED (0-7) that corresponds to the OP link station number (9-15) which caused the reference alarm goes on.
In the example, address 9 is abnormal.

● Communication setup mode

This mode is used for switching processor module modes (RUN, STOP, TEST and PROGRAM) and communication settings for the different connectors (LOAD connector, ASCII connector, CBL connector and OPI/O terminal).

● Setting flow

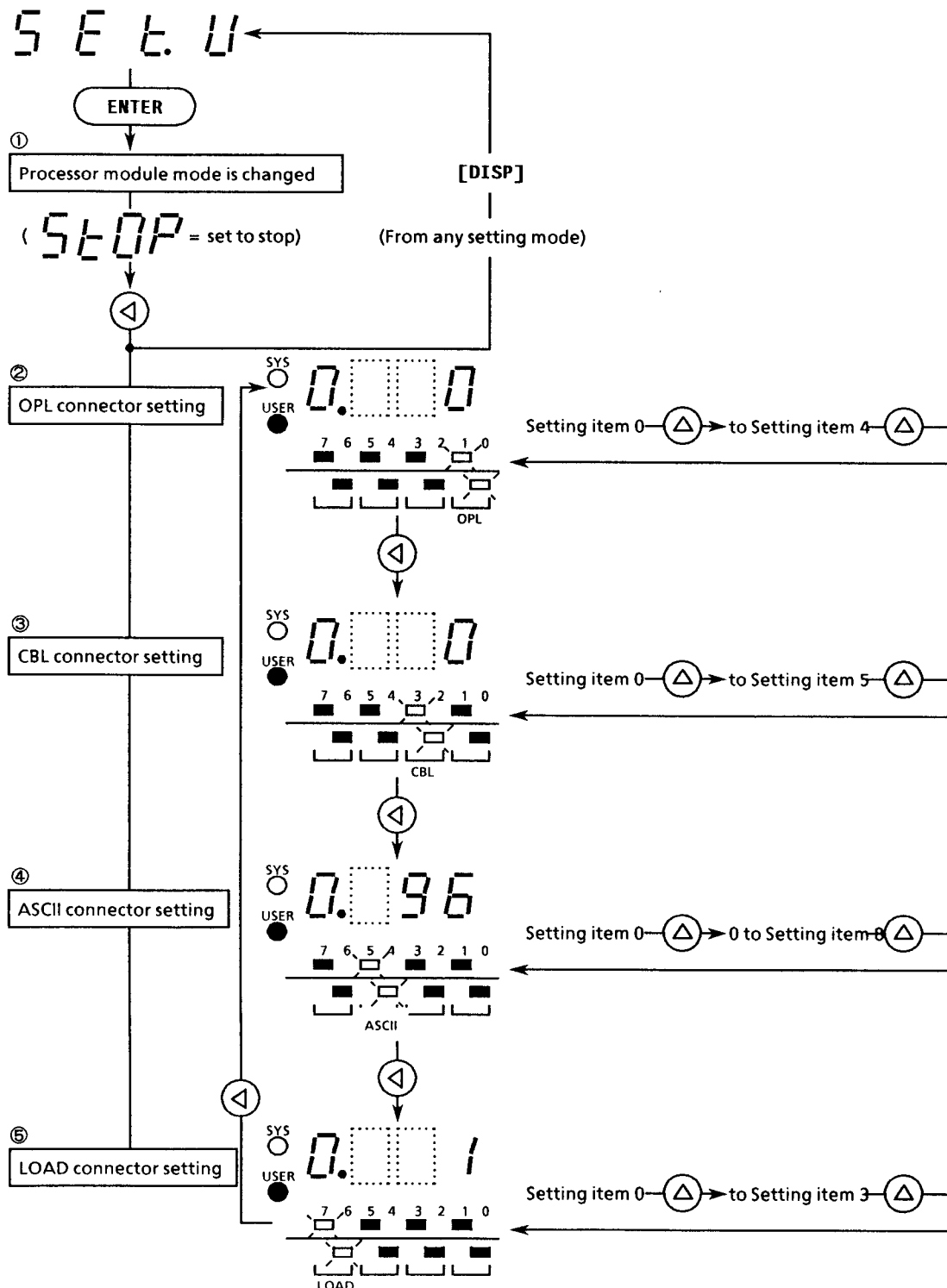

① Mode changes for processor module

Item	Description	Initial value
Changes in processor module modes	<ul style="list-style-type: none"> Selects whether the processor module is to RUN or STOP. 	<p>STOP</p> <p>(STOP)</p>

• Operation procedures

The 7-segment LED displays the current status of the processor module.

S E T U

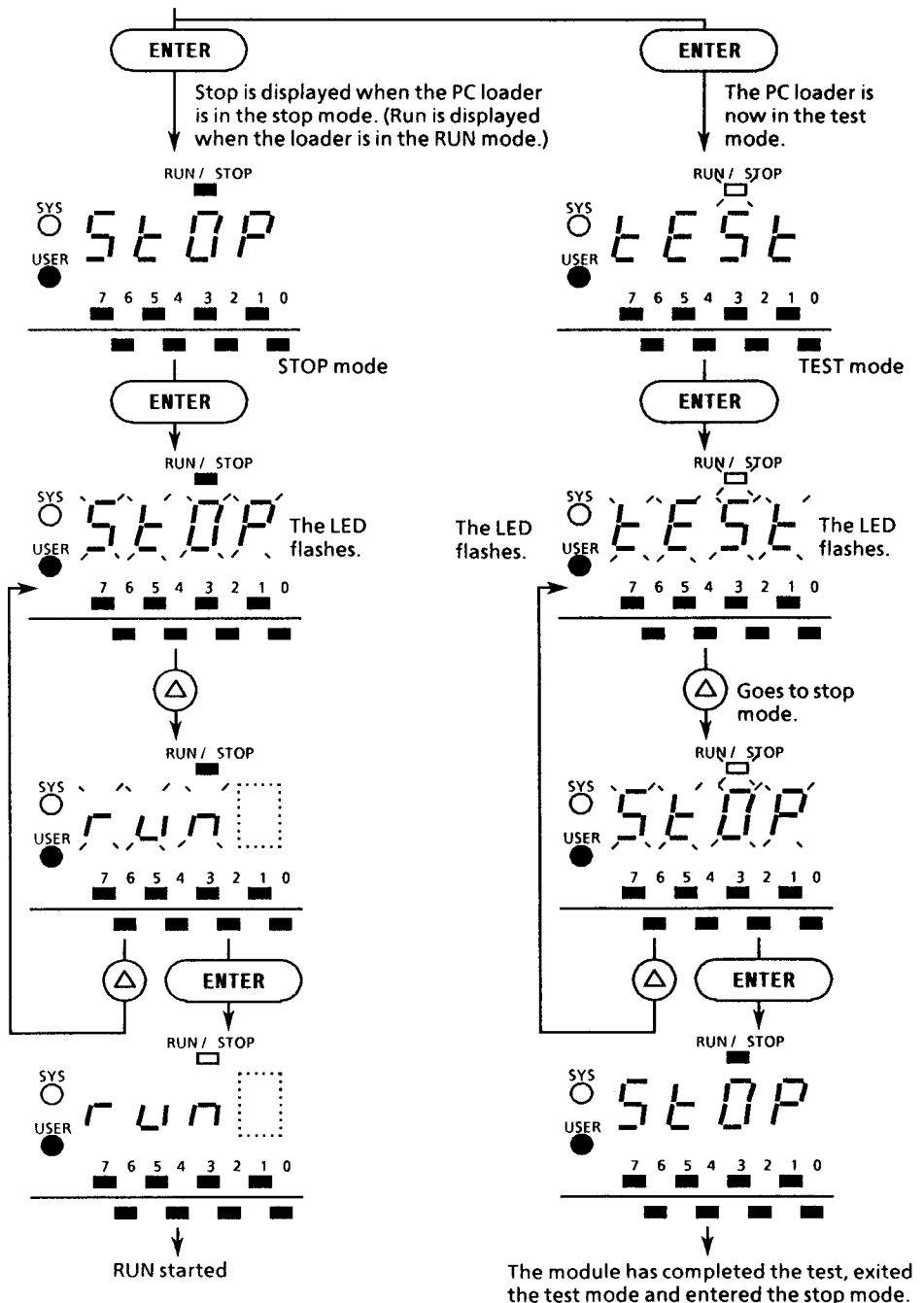

② OP I/O terminal settings

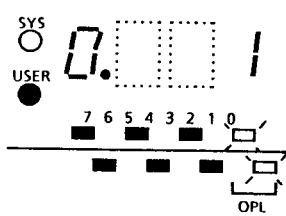
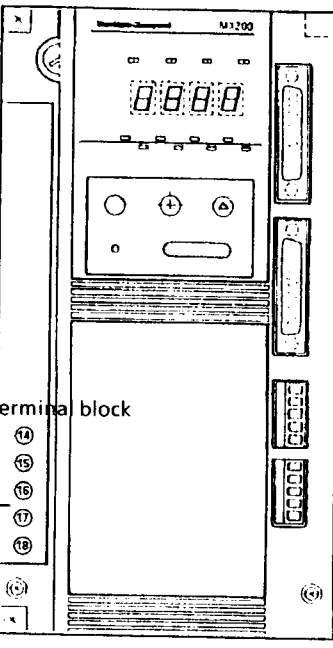
	Setting items	Initial value
<p>OP I/O terminal settings</p>  <p>Bit 0 and bit 1 of the 8-bit LED flashes to indicate that the OP I/O terminal setting mode is selected.</p>  <p>Terminal block</p> <p>OP I/O terminal</p>	<p>Item 0 : Sets the station number of OP link communication (range of setting items: 0-15).</p> <p>Indicates that the terminal is used as an OP link.</p> <p>Item 1: Baud rate selection Selects one of the following Baud rates: 19200bps, 9600bps, 4800bps or 2400bps.</p> <p>Item 2: Communication format selection Sets either 8 data bits, even parity and 1 stop bit or 8 data bits, no parity and 2 stop bits.</p> <p>Item 3: Host (master) or slave selection.</p> <ul style="list-style-type: none"> When the host is selected, the address settings of the OP link communication is ignored. When the slave is selected, make sure that duplicate station numbers for OP link communication are not set. <p>Item 4: OP I/O terminal usage</p> <ul style="list-style-type: none"> Determines whether the terminal is to be used as an OP/I terminal or as an ASCII communication connector. When the terminal is to be used as an ASCII communication connector, perform the settings described in ④ "ASCII Connector Settings." 	<p>Indicates item number.</p> <p>Initial value is 0.</p> <p>Goes to item 1.</p> <p>Indicates 19200bps</p> <p>Goes to item 2.</p> <p>8 data bits, even parity and 1 stop bit.</p> <p>Goes to item 3.</p> <p>Host (master) setting</p> <p>Goes to item 4.</p> <p>Indicates that the terminal is used as an OP link.</p> <p>Goes to item 1 (announced by a beep).</p>

Operation and Setting Procedures

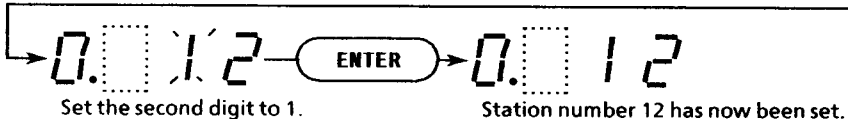
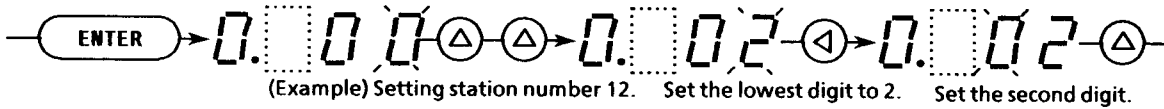

- Numbers are incremented with the Δ key (9-> 1-> 0).
- Use the \leftarrow key to go between digits.
- When the number of a station is a single digit number, a 0 is not displayed in the second digit.
- Station number 0 can be used for the host (master) only.

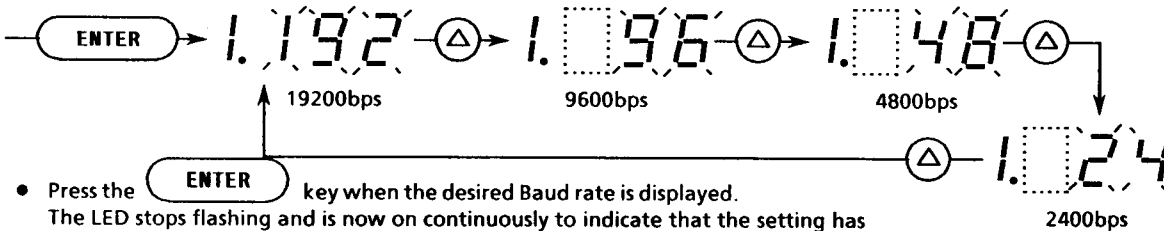

- Press the **ENTER** key when the desired Baud rate is displayed. The LED stops flashing and is now on continuously to indicate that the setting has been made.

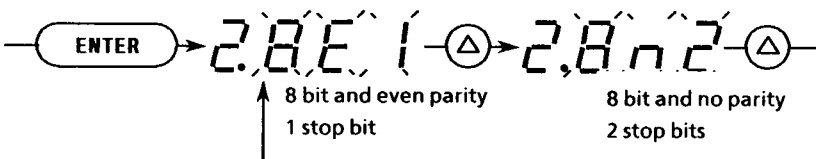

- Press the **ENTER** key when the desired communication format is displayed. The LED stops flashing and is now on continuously to indicate that the setting has been made.

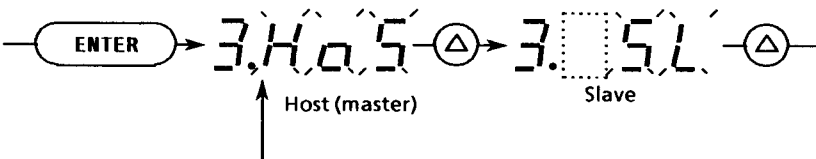



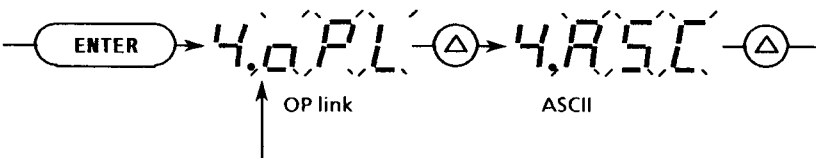





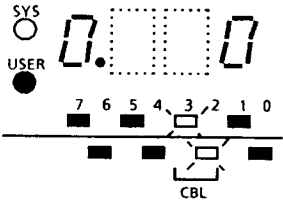
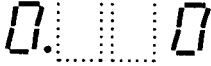

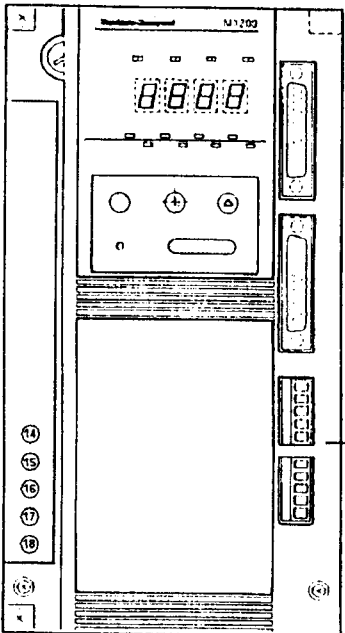
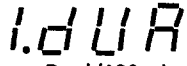

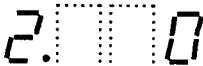
- Press the **ENTER** key when the desired setting is displayed. The LED stops flashing and is now on continuously to indicate that the setting has been made.

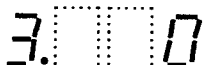

- Press the **ENTER** key when the desired setting is displayed. The LED stops flashing and is now on continuously to indicate that the setting has been made.

③ CBL connector settings

	Settings	Initial value
<p>CBL connector settings</p>  <p>Bit 2 and 3 on the 8-bit LED indicator flashes to indicate that the CBL connector setting mode is selected.</p>	<p>Item 0: Sets communication to 1 destination (no response), or to reception/no reception of broadcast commands in the CBL communication function, and enters a group number if reception is selected.</p>	<p>Indicates item number</p>  <p>0 indicates no reception</p>  <p>Goes to item 1.</p>
 <p>CBL connector</p>	<p>Item 1: Selects processor link and the amount of reception data to be received during a remote communication. Dual receives a 100 words. Single receives 50 words.</p>	 <p>Dual (100 w)</p>  <p>Goes to item 2.</p>
	<p>Item 2: Sets the number of send destination groups during processor linking. 0 = no transmission 1 = Destination group 1 2 = Destination group 2 3 = Destination group 3</p>	 <p>No transmission</p>  <p>Goes to item 3.</p>
	<p>Item 3: Determines which reception group is to be set for the processor link.</p>	 <p>No reception</p>  <p>Goes to item 4.</p>
<p>*This setting can be made only on models MX200 CP01T and MX200CP01P.</p>	<p>Item 4: Sets the monitoring time of reception data during processor linking. Set 500 ms or 1 second.</p>	 <p>500ms</p>  <p>Goes to item 5</p>
	<p>Item 5: Selects the CBL communication format.</p>	 <p>NRZ format</p>  <p>Goes to item 0.</p>

Operation and Setting Procedures

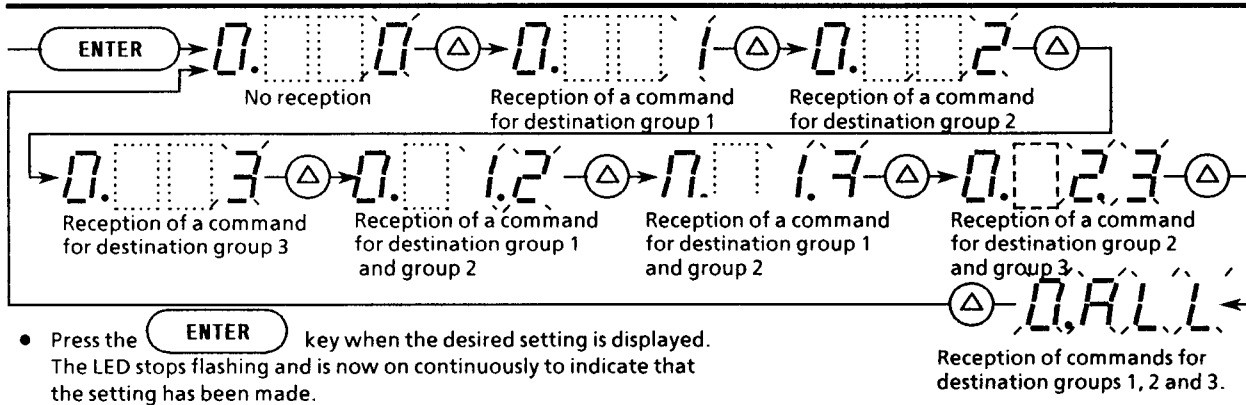

- Press the **ENTER** key when the desired setting is displayed. The LED stops flashing and is now on continuously to indicate that the setting has been made.

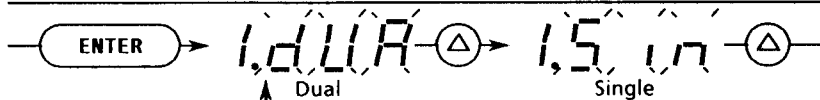

- Press the **ENTER** key when the desired setting is displayed. The LED stops flashing and is now on continuously to indicate that the setting has been made.

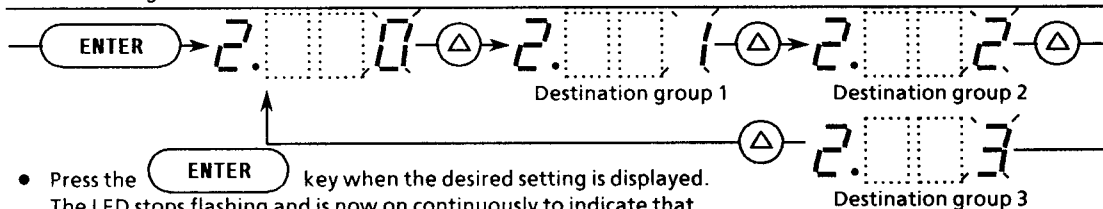

- Press the **ENTER** key when the desired setting is displayed. The LED stops flashing and is now on continuously to indicate that the setting has been made.

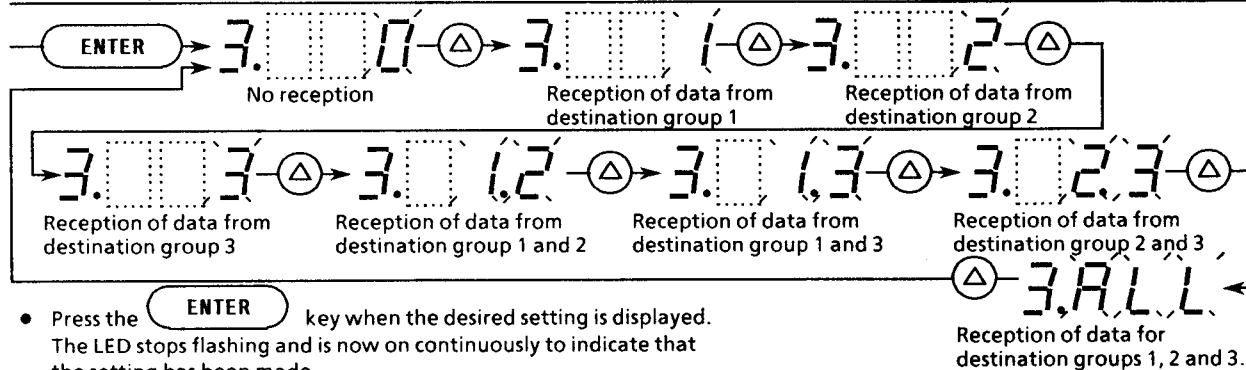

- Press the **ENTER** key when the desired setting is displayed. The LED stops flashing and is now on continuously to indicate that the setting has been made.

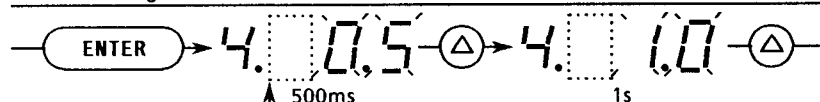

- Press the **ENTER** key when the desired setting is displayed. The LED stops flashing and is now on continuously to indicate that the setting has been made.

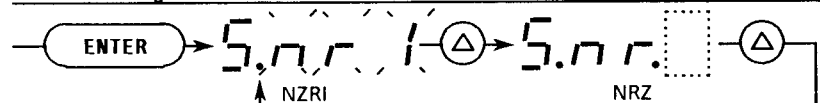

- Press the **ENTER** key when the desired setting is displayed. The LED stops flashing and is now on continuously to indicate that the setting has been made.

④ ASCII connector settings

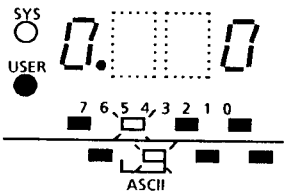
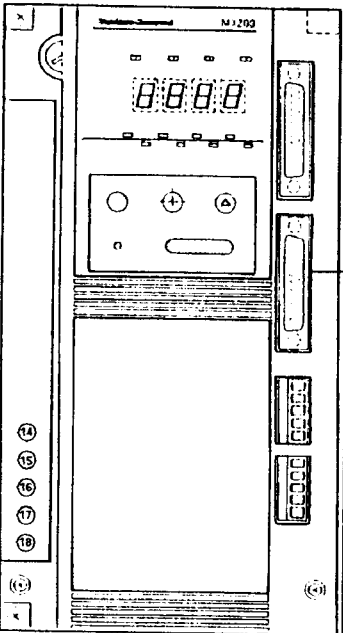
	Setting items	Initial value
<p>ASCII connector settings</p>  <p>Bit 4 and bit 5 on the 8-bit LED flashes to indicate that the ASCII connector setting mode is selected.</p>	<p>Item 0: Baud rate selection Selects one of the following Baud rates: 19200bps, 9600bps, 4800bps, 2400bps, 1200bps, or 600bps.</p>	<p>Indicates item number.</p> <p>0.96 9600bps</p> <p>↑</p> <p>△</p> <p>↓</p> <p>Goes to item 1.</p>
	<p>Item 1: Data length selection Selects data length. Set either 7 bits or 8 bits.</p>	<p>1.8b 8 bits</p> <p>↑</p> <p>△</p> <p>↓</p> <p>Goes to item 2.</p>
	<p>Item 2: Parity bit selection. Selects no parity, even parity or odd parity.</p>	<p>2.EP Even parity</p> <p>↑</p> <p>△</p> <p>↓</p> <p>Goes to item 3.</p>
	<p>Item 3: Stop bit selection Selects 1 or 2 stop bits.</p>	<p>3.15 1 stop bit</p> <p>↑</p> <p>△</p> <p>↓</p> <p>Goes to item 4.</p>
	<p>Item 4: ASCII connector usage Determines whether it is to be used as an ASCII connector or as a host communication connector.</p>	<p>4.ASC ASCII connector</p> <p>↑</p> <p>△</p> <p>↓</p> <p>Goes to item 5.</p>
 <p>ASCII connector</p>	<p>Item 5: Selection of devices to be connected to the ASCII connector. Selects general-purpose device or device supporting Yamatake communication protocol. (Example: Digitronic, ST-series)</p>	<p>5.9En General purpose device</p> <p>↑</p> <p>△</p> <p>↓</p> <p>Goes to item 6.</p>
	<p>Item 6: Communication format for RS-485 Selects 5-line (full duplex) or 3-line (half duplex).</p>	<p>6.5 5-line (full duplex) communication</p> <p>↑</p> <p>△</p> <p>↓</p> <p>Goes to item 7.</p>

Operation and Setting Procedures

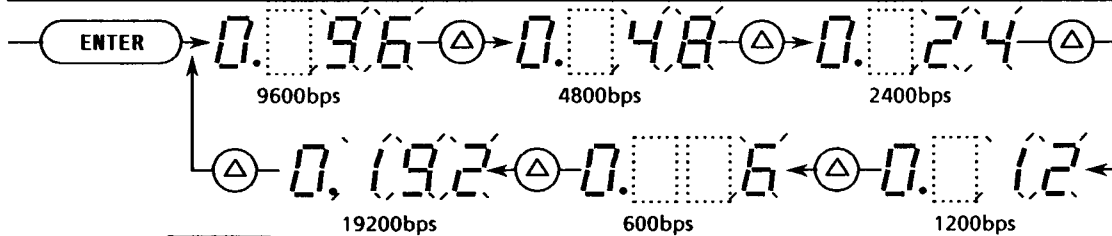

- Press the **ENTER** key when the desired setting is displayed. The LED stops flashing and is now on continuously to indicate that the setting has been made.

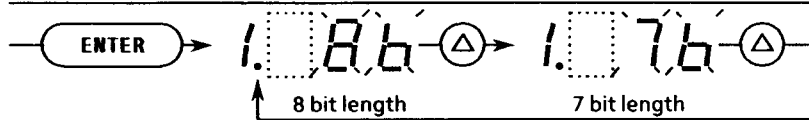

- Press the **ENTER** key when the desired setting is displayed. The LED stops flashing and is now on continuously to indicate that the setting has been made.

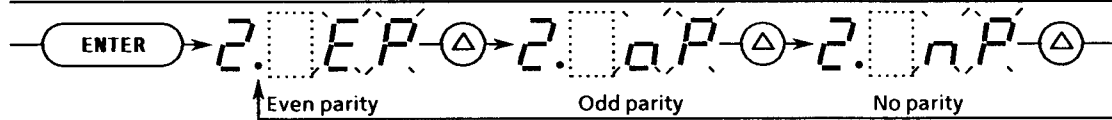

- Press the **ENTER** key when the desired setting is displayed. The LED stops flashing and is now on continuously to indicate that the setting has been made.

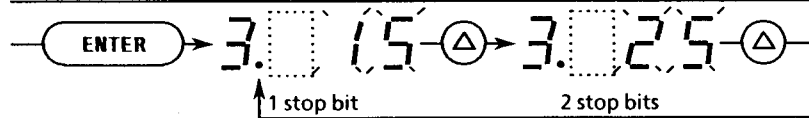

- Press the **ENTER** key when the desired setting is displayed. The LED stops flashing and is now on continuously to indicate that the setting has been made.

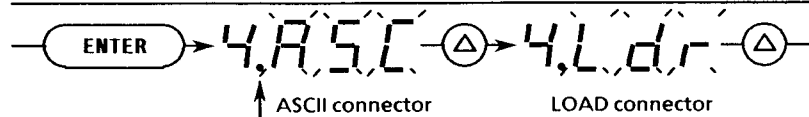

- Press the **ENTER** key when the desired setting is displayed. The LED stops flashing and is now on continuously to indicate that the setting has been made.

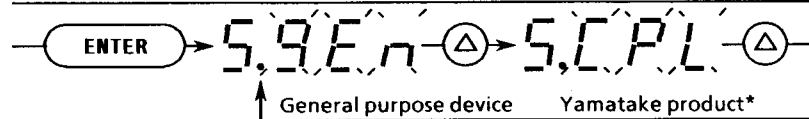

* Check the communication format of a device before connecting it. (Connect a host communication device.)

- Press the **ENTER** key when the desired setting is displayed. The LED stops flashing and is now on continuously to indicate that the setting has been made.

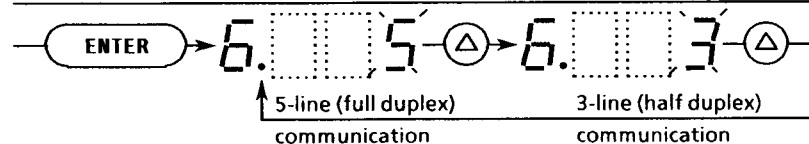

- Press the **ENTER** key when the desired setting is displayed. The LED stops flashing and is now on continuously to indicate that the setting has been made.

	Setting items	Initial value
	Item 7: Determines whether RTS control of RS-232C is to be set or not.	<p>7.nnn</p> <p>No RTS control</p> <p>⬇</p> <p>Goes to item 8.</p>
	Item 8: Determines whether RS-232C or RS-485 is to be used for the ASCII connector.	<p>8.232</p> <p>RS-232C</p> <p>⬇</p> <p>Goes to item 0 (announced by a beep).</p>