

TDC 3000 BASIC

Advanced Multifunction Controller (A-MC)

Introduction

The Advanced Multifunction Controller (A-MC) is able to handle a wide variety of continuous, batch and hybrid processes. The A-MC contains the hardware and software necessary to receive analog, digital and pulse inputs from field devices, perform control computations according to the assigned algorithms and control sequences, and provides the resulting analog and digital outputs to the field. Also, the Smart Transmitter Digital Communication Module (STDCM) allows digital communication with Yamatake's smart field instruments. One A-MC is able to handle up to the following numbers of signals:

- Analog inputs: 32
- Analog outputs: 72
- Digital inputs: 256
- Digital outputs: 144
- Pulse inputs: 64
- Smart transmitter digital communication: 16 transmitters max.

Communication among A-MCs (up to 16 units) is accomplished through a redundant EC-Link. The A-MC can be hooked up to a TDC 3000 Data Hiway through a Hiway Internal Cable (HIC) and a Hiway Cable Interface (HCIM). The Input/Output Module (IOM) can be connected to the controller through a high-speed duplex serial bus (X-bus). The input/output field signals are connected to the I/O Module via the Front Terminal Block (FTB) on the module's front or the Remote Terminal Panel (RTP), which is connected to the module through a dedicated cable.

The field inputs and outputs can also be connected through the signal converter (SystempaK).

The A-MC can be optionally provided with an Uninterrupted Automatic Control (UAC) function by employing a redundancy structure for the control modules, communication module and I/O modules. The UAC function greatly enhances system availability and reliability.

Functions

The A-MC provides the following functions:

- Modulating Control
- The A-MC receives analog or smart field instrument inputs, per-



Advanced Multifunction Controller

forms control computations with the assigned algorithms, and provides the resultant analog control signals to field devices.

- I/O Monitoring
- The A-MC monitors analog and digital input/output, pulse (counter) input and smart field device input signals, and generates alarm signals.
- Logic Control
- The A-MC performs 11 types of logic operation (AND, OR, etc.) on signals from its respective logic blocks.
- Sequence Control
- The A-MC enables high-level operational control or sequence control by employing a dedicated process control language, CL/MC, or a Sequence Oriented Procedural Language, SOPL.
- Communication

The A-MC can be hooked up to a TDC 3000 Data Hiway to communicate with an Enhanced Operator Station (EOS III, EOS III-J), or other preferred devices on the hiway. Communication among different A-MC units is performed through the EC-link to allow exchange of the input/output and control-related information. It is also hooked up to a TDC 3000 Local Control Network (LCN) via a Hiway Gateway (HG) and the data hiway.

The EC-link can be extended up to 100 meters and connected to up to 8 A-MCs. The Data Hiway can be extended up to 1.5 km (with coaxial cables for one branch) and can connect up to 31 A-MCs for remote

monitoring and control operation. By employing optical cables, the Data Hiway can be extended up to 5 km per branch. (3 branches/Data Hiway, max.)

- Smart Transmitter Communication
- The Smart Transmitter Digital Communication Module (STDCM) enables digital communication with smart field instruments like the differential transmitter ST 3000. It provides high precision process variable (PV) transmission as well as utilizing multivariable information and the diagnostic results of field devices. The STDCM can process smart field instrument inputs as well as conventional analog inputs.
- Self-Diagnostics
- The A-MC self-diagnoses the above functions periodically. If a failure is detected, it is immediately indicated by the LED indicators on the Multifunction Control Module (MCM) and the contents of the failure are displayed on the Operator Station.
- Uninterrupted Automatic Control (UAC)

The entire A-MC communication system (including Data Hiway, EC-link and internal buses) offers redundancy as a standard feature. As an optional feature, a redundancy structure is also available for the Multifunction Control Module, the Hiway Interface Module, the Analog Input Module, Analog Output Module, Pulse Input Module, and Smart Transmitter Digital Communication Module. The redundancy structure greatly enhances system availability and reliability.

bility since, should the current module (primary module) fail, the standby module (reserve module) is immediately and automatically brought into operation.

Structure

The A-MC consists of a base plate, backplane, and modules. The base plate can be installed in a standard

TDC cabinet using an adaptor.

The combination of base plate and backplane is called the base unit, into which functional modules are installed.

Figure 1 shows the base units and corresponding functional modules. The module location in Figure 1 shows the mounting numbers of the modules. The I/O slot means the processing unit for the optional I/O on the software of

the A-MC (the optional I/O in the A-MC is divided into 16 slots to allow sequential processing).

The modules which make up a nonredundancy A-MC structure are shown in Table 1 and Figures 1 and 2, and those which make up a redundancy structure are shown in Table 2 and Figure 3.

Table 1. A-MC Structure (nonredundancy)

Base Unit	Module Location	Resident Modules	Option	
Base Unit	12	Multifunction Control Module (MCM)		
	11	Hiway Interface Module (HIM)		
	10	Analog Output Module (AOM)		
	9	Hi-Level Analog Input Module (HAIM) or Smart Transmitter Digital Communication Module (STDCM)		
	8			Optional I/O Modules (For I/O Modules and their locations, see Figure 1.)
	7			
	6			
	5			
	4			
	3			
	2			
	1			

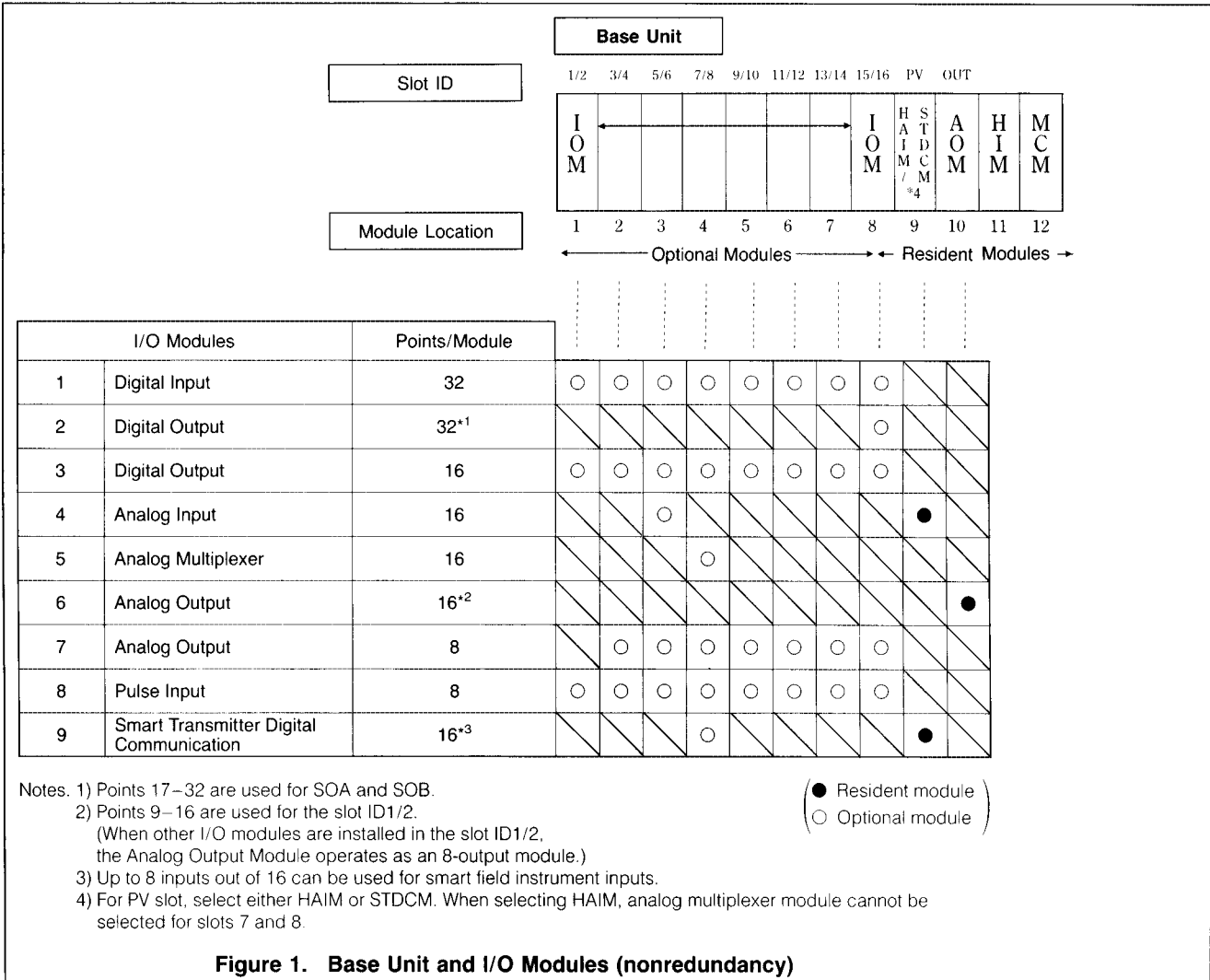
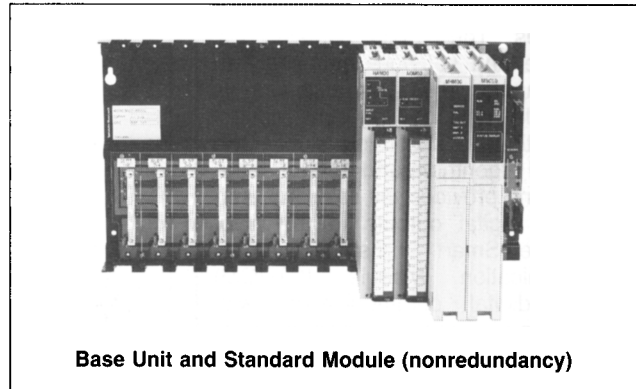

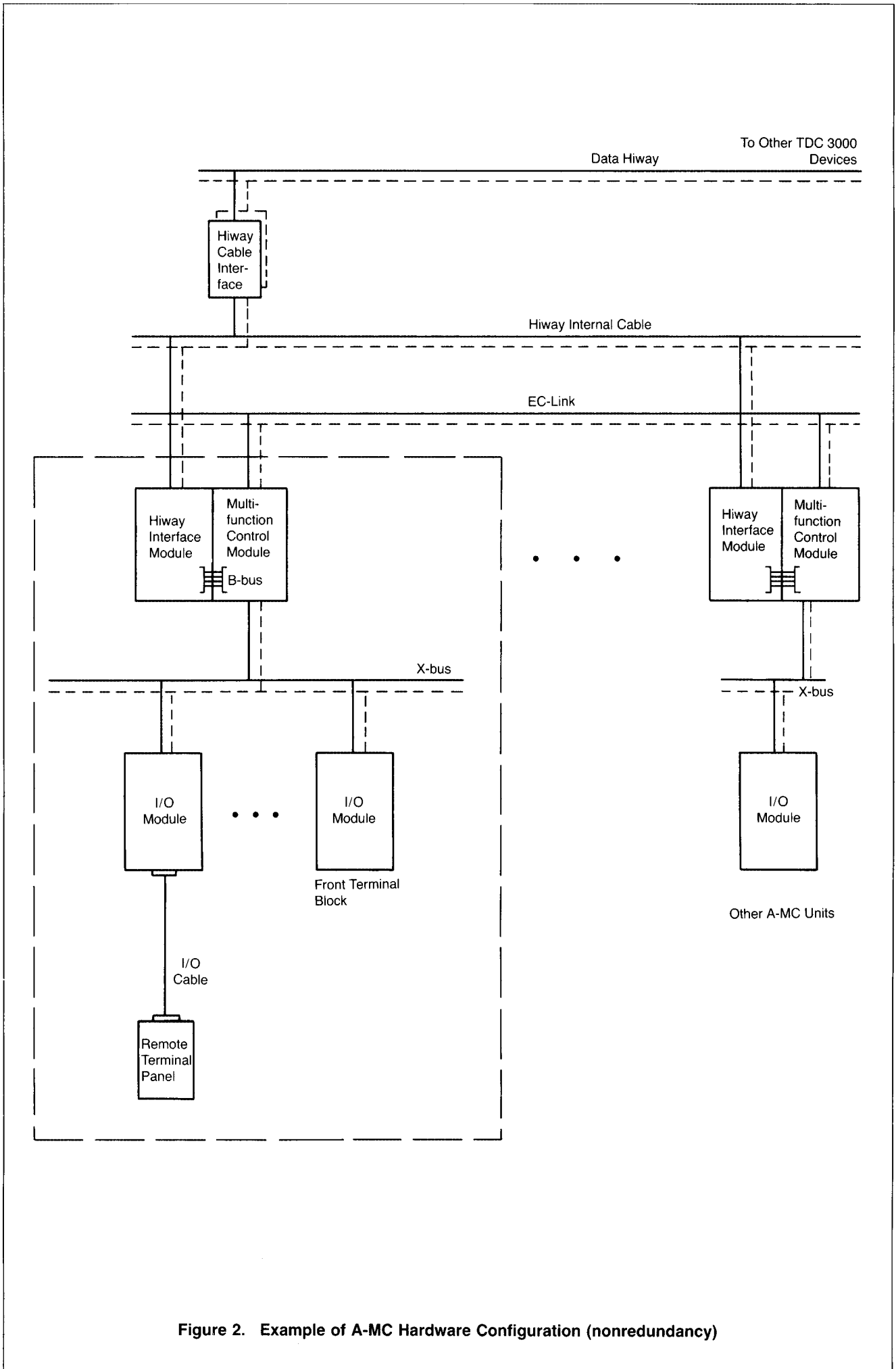
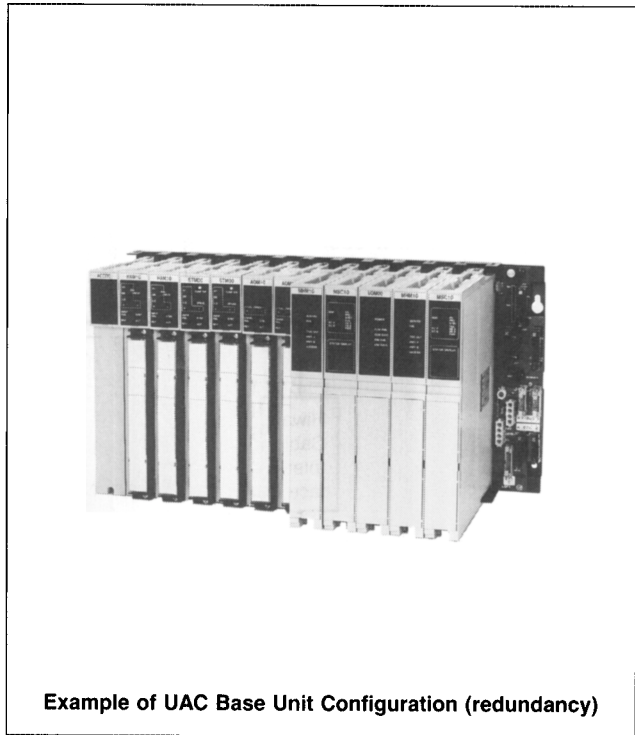

Figure 2. Example of A-MC Hardware Configuration (nonredundancy)

Table 2. A-MC Configuration (redundancy)

Base Unit	Module Location	Resident Modules	Option	
UAC Base Unit	12	Multifunction Control Module (MCM): primary	/	
	11	Hiway Interface Module (HIM): primary		
	10	UAC Director Module (UDM)		
	9	Multifunction Control Module (MCM): reserve		
	8	Hiway Interface Module (HIM): reserve		
	7	Analog Output Module (AOM): primary		
	6			AOM: reserve
	5	Hi-level Analog Input Module (HAIM): primary Smart Transmitter Digital Communication Module (STDCM)		
	4			HAIM: reserve/ STDCM: reserve
	3			Optional I/O Modules (See Figure 3.)
2				
	1	Not used.		
I/O Base Unit	12 to 1		Optional I/O Modules (See Figure 3.)	



Example of UAC Base Unit Configuration (redundancy)

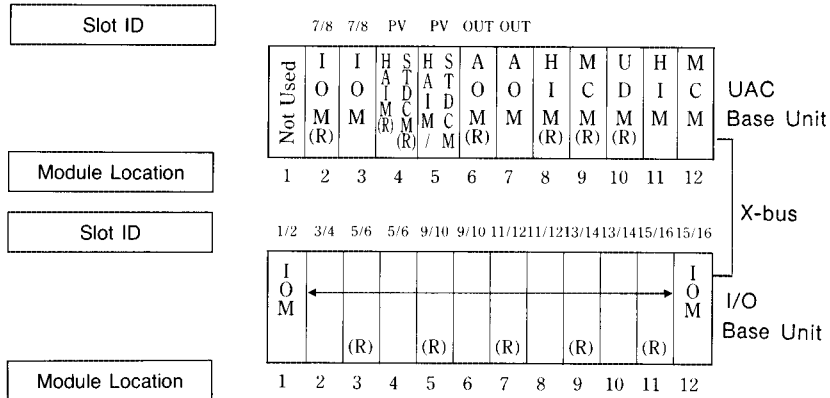

* The I/O Base Unit is an optional for use when the number of I/O modules exceeds the UAC Base Units limit. The slots marked with "(R)" are for reserve modules. The analog input and analog output modules, pulse input modules and Smart Transmitter Communication Module can be backed up with reserve I/O modules under the conditions indicated below.

I/O Module	Points/Module	Slot ID										PV	OUT	
		1/2	3/4	5/6	7/8	9/10	11/12	13/14	15/16					
1 Digital Inputs	32	○	○	○	○	○	○	○	○	○	○	○	○	○
2 Digital Outputs	32 ¹	○	○	○	○	○	○	○	○	○	○	○	○	○
3 Digital Outputs	16	○	○	○	○	○	○	○	○	○	○	○	○	○
4 Analog Inputs	16	○	○	○	○	○	○	○	○	○	○	○	○	○
5 Analog Outputs	16 ²	○	○	○	○	○	○	○	○	○	○	○	○	○
6 Analog Outputs	8	○	○	○	○	○	○	○	○	○	○	○	○	○
7 Pulse Inputs	8	○	○	○	○	○	○	○	○	○	○	○	○	○
8 Smart Transmitter Digital Communication	16 ³	○	○	○	○	○	○	○	○	○	○	○	○	○

● Resident module
○ Optional module

- Notes. 1) Points 17–32 are used for SOA and SOB.
 2) Points 9–16 are used for slot ID1/2. (When other I/O modules are installed in slot ID1/2, the analog output module operates as an 8-output module.)
 3) Up to 8 inputs out of 16 can be used for smart field instrument inputs.
 4) Select either HAIM or STDCM for PV slot. Use the same module type for the primary and the secondary.

Figure 3. UAC Base Unit and I/O Modules (redundancy)

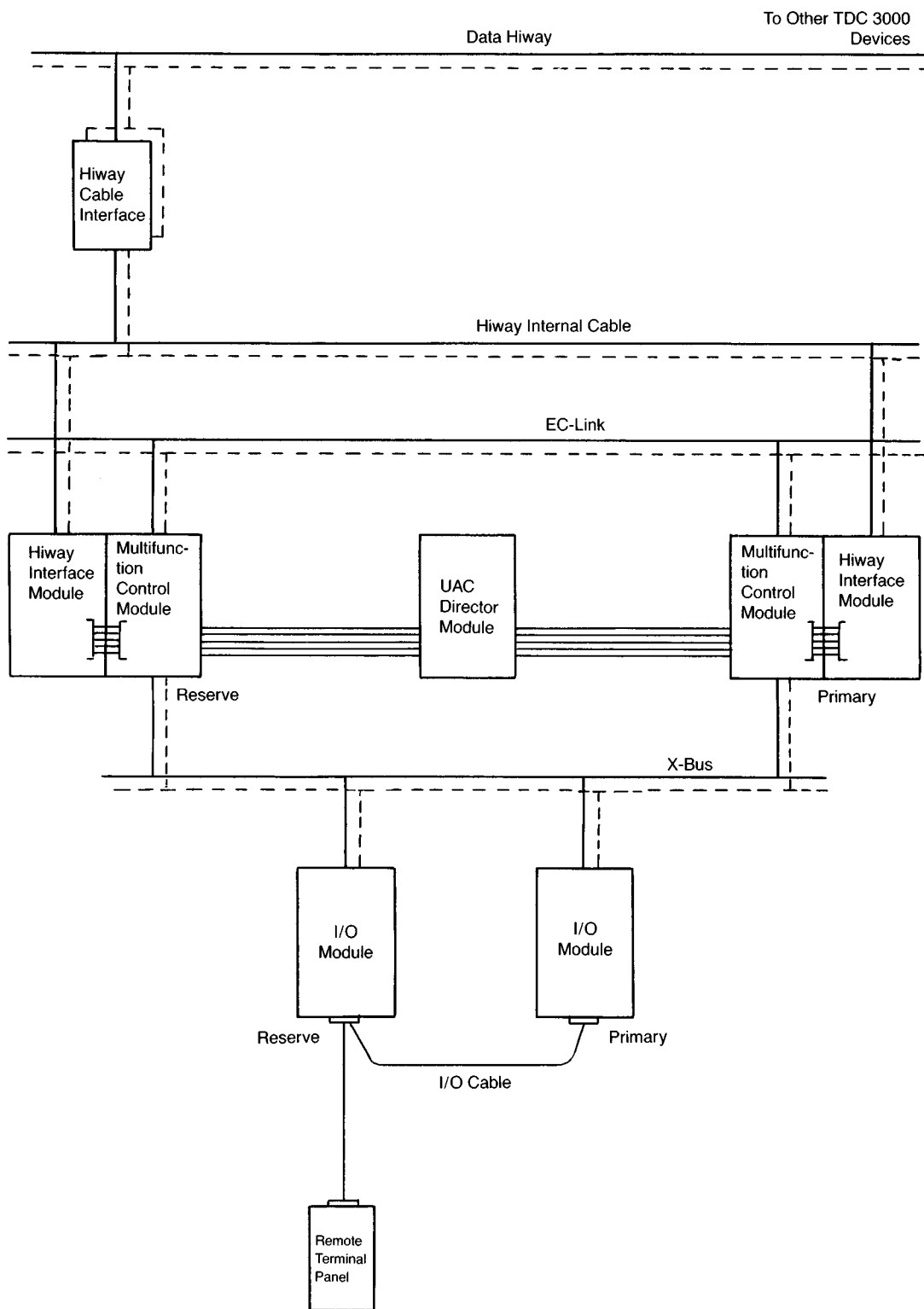

Figure 4. Example of A-MC Hardware Configuration (redundancy)

Multifunction Control Module (MCM)

The Multifunction Control Module is the main component of the A-MC. It contains the CPU, RAM, EPROM, X-bus interface, EC-Link interface, DC/DC regulators, and shutdown timer. LEDs mounted on the Multifunction Control Module provide status information.

Hiway Interface Module (HIM)

The Hiway Interface Module (HIM) enables the A-MC to communicate with other TDC 3000 Data Hiway devices such as the Enhanced Operator Station III and the Hiway Gateway. The HIM connects to redundant Hiway Internal Cables (HIC) which in turn are connected to the TDC 3000 Data Hiway through redundant Hiway Cable Interfaces (HCIM).

The Hiway address of the A-MC is set by switches behind the HIM front panel. The A-MC occupies 2 Hiway addresses. LEDs mounted on the HIM provide status information.

UAC Director Module (UDM)

The UDM directs module switching and transfers data bases for the UAC function. It acts also as a local interface, with a UAC status indicator LED and manual selector switches.

Hiway Cable Interface (HCIM)

The Hiway Cable interface (HCIM) connects the Data Hiway to the A-MC's Hiway Internal Cables (HIC) and converts HIC signals from/to Data Hiway signals.

I/O Modules (IOM)

There are three types of modules —one for analog inputs/outputs, one

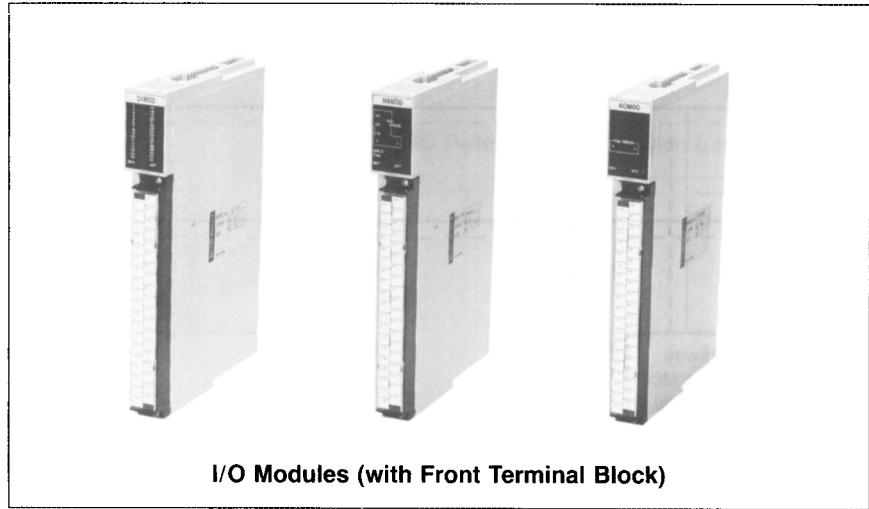
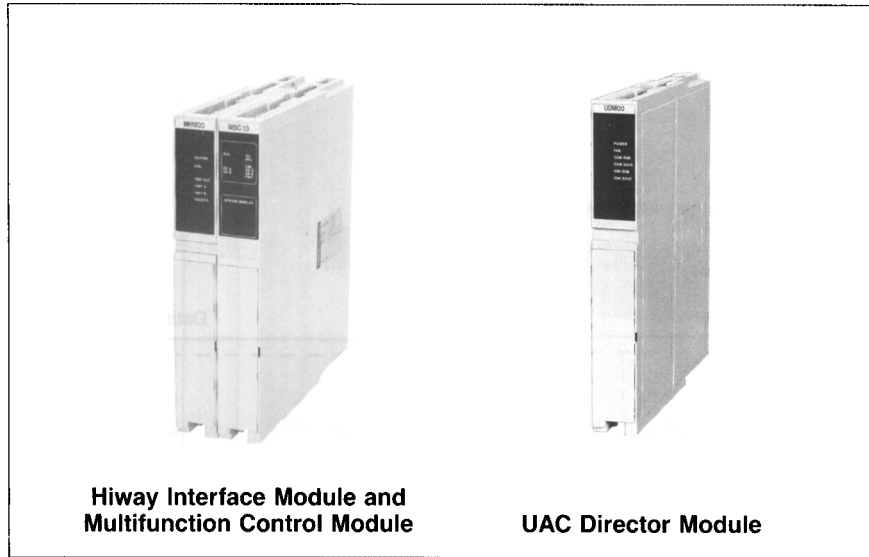

for digital inputs/outputs, and another one for pulse inputs. All of them operate on a 24 Vdc power supply. They

have LEDs to indicate the input/output signal status and the module status (READY, ACTIVE STANDBY or FAIL).

Table 3. A-MC I/O Module List

	Name	Model No.	Description	Redundancy
Standard package module	Analog input module	J-HAM10	1 to 5 V input, 16 points/module	A
	Smart transmitter digital communication module	J-STM00	1 to 5 V input, 16 points/module (Up to 8 inputs can be used for digital communication with the Smart Transmitter.) Select J-HAM10 or J-STM00.	A
	Analog output module	J-AOM10	4 to 20 mA output, 16 points/module	A
Optional module	Analog input module	J-HAM10	1 to 5 V input, 16 points/module Used as an optional analog input for redundancy configurations.	A
	Analog multiplexer module	J-HMM00	1 to 5 V input, 16 points/module Used as an optional analog input for nonredundancy configurations.	N/A
	Smart transmitter digital communication module	J-STM00	1 to 5 V input, 16 points/module (Up to 8 inputs can be used for digital communication with the Smart Transmitter.)	A
	Analog output module	J-AOM10	4 to 20 mA output, 8 points/module (Use 8 outputs of same module as standard package.)	A
	Digital input module	J-DIM00	24 Vdc input (dry contact), 32 points/module	N/A
	Digital input module	J-DIM10	48 Vdc input (dry contact), 32 points/module	N/A
	Digital output module	J-DOM00	Semiconductor (open-collector) output, 16 points/module	N/A
	Digital output module	J-DOM10	Semiconductor (open-collector) output, 32 points/module One A-MC uses one module.	N/A
	Digital output module	J-DOM20	Relay (C-contact) output, 16 points/module The relay is packed on the module.	N/A
	Pulse input module	J-PIM00	24 Vdc input (dry contact), 8 points/module Up to 5 kHz Voltage pulse can be used by combining with the auxiliary device.	A
Accessory module	J-ACC00	Module for space slot	---	

EC-Link Adaptor (ECLA)

When the EC-Link is mounted between the cabinets, it uses the EC-Link Adaptor (ECLA). The ECLA is directly mounted on the cabinet. TB1 and TB2 connect the external EC-Link and the terminator.

Field Termination

Input and output connection terminals to the field are designed to cope with a wide range of wiring requirements. The Front Terminal Block (FTB) termination type allows direct connection of field wiring to the front end of the I/O modules. The Remote Terminal Panel (RTP) allows connection between the terminal panel mounted in the cabinet or the relay terminal panel and the I/O modules via a dedicated cable (up to 100 m). The field signals can be connected to the terminal through the systempaK signal converter.

It provides a total of 9 types of RTPs depending on the kinds of inputs and outputs: for digital input/output, digital output, analog input, analog output, pulse input and extended digital output. One type of FTB allows connection to a range of inputs and outputs. The remote terminal panel for analog output (for standby manual) provides the connector to connect the

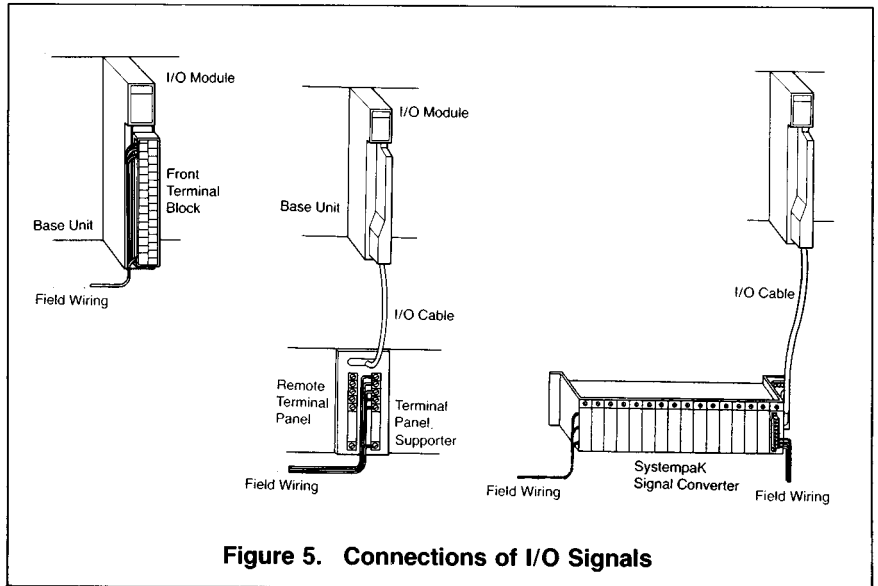
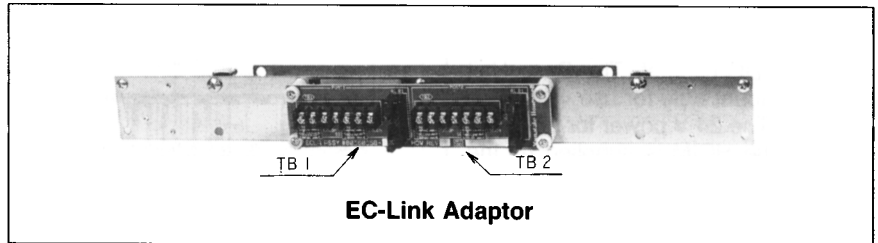

Figure 5. Connections of I/O Signals

standby manual unit. The RTP for analog input provides the transmitter power supply, current limiter circuit and current-voltage conversion resistor.

Table 4. Remote Terminal Panel

Name	Model No.	Available I/O module Combination	Description
Analog input RTP	J-RTP10	J-HAM10 J-HAM00 J-STM00	Transmitter power supply available (24 Vdc) With current limiter circuit 16 inputs, 4 to 20 mA or 1 to 5 V (Selectable for each input)
Analog output RTP	J-RTP20	J-AOM10	16 or 8 outputs can be used. 4 to 20 mA
	J-RTP30	J-AOM10	Standby manual unit can be connected in conjunction with the RTP20
Digital input RTP	J-RTP00	J-DIM00 J-DIM10	32 inputs, dry contact input
Digital output RTP	J-RTP00	J-DOM00 J-DOM10	16 outputs, open-collector output 32 outputs, open-collector output
	J-RTP40	J-DOM00	32 outputs, open-collector output (One J-RTP40 requires 2 modules of J-DOM00.)
	J-RTP80	J-DOM20	16 outputs, relay output (Relay is on the DO module (not on the RTP.))
Extended digital output RTP	J-ETP00	J-DOM00	16 outputs, relay output (Relay is on the RTP and open collector is corrected to a relay output.)
Pulse input RTP	J-ETP50	J-PIM00	8 inputs, dry contact input

Auxiliary terminal

In addition to the terminal for field input/output, this terminal provides devices which display external system status, initialize UAC backup by an external contact input, and judge power interruptions and failures.

The Base Unit Terminal (J-BTP00) provides the contact outputs to show the UAC backup state and UAC disable state and the contact inputs to initialize the UAC backup and restart after an interruption. The Power Down Monitor (J-PDM00) monitors the ac power supply and commands the restart procedure to the A-MC by comparing actual ac interruption time with the interruption definition time. Connection between the Power Down Monitor and the A-MC Base Unit is accomplished through the Base Unit Terminal.

Power Supply and Grounding Requirements

AC Power Requirements	Type: J-STX5□/6□ Voltage: ac 105/115/230 V ±15% Frequency: 50/60 Hz ±1 Hz
DC Power Requirements	Voltage: 22 to 30 V Ripple: 0.8 Vp-p Interruptions: <1 ms
Grounding Requirements	One grounding point for each of the following is required. <ul style="list-style-type: none"> • Protective ground (FG) Class 3 • System ground (SG) Class 1 or Special Class 3

Mounting and Dimensions

The A-MC can be mounted in a standard TDC cabinet. The Base Unit is a rack-mount type for use with a 19-inch rack. The 24 V power for the Base Unit and the HCIM is supplied by the exclusive cable through a distributor panel installed in the cabinet. The Remote Terminal Panel (RTP) can be installed in the cabinet mounting brackets (sub-panel). The HCIM and ECLA can be directly installed in the TDC cabinet.

The dimensions of the above devices are shown in Figures 6 through 10.

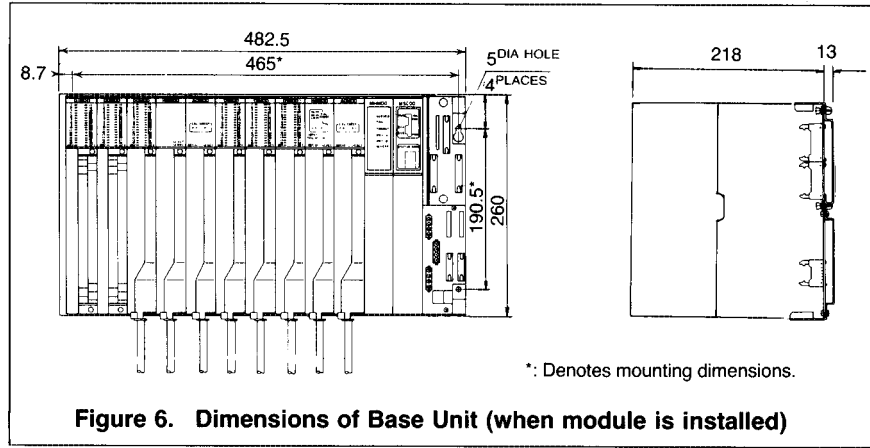

Figure 6. Dimensions of Base Unit (when module is installed)

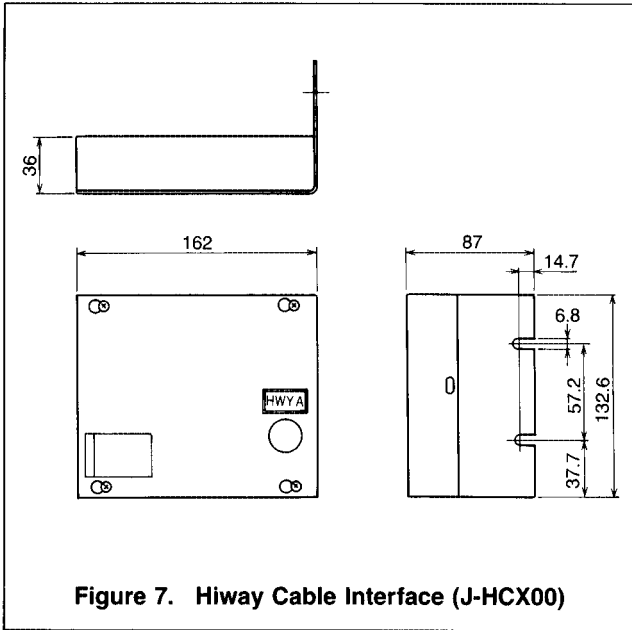

Figure 7. Hiway Cable Interface (J-HCX00)

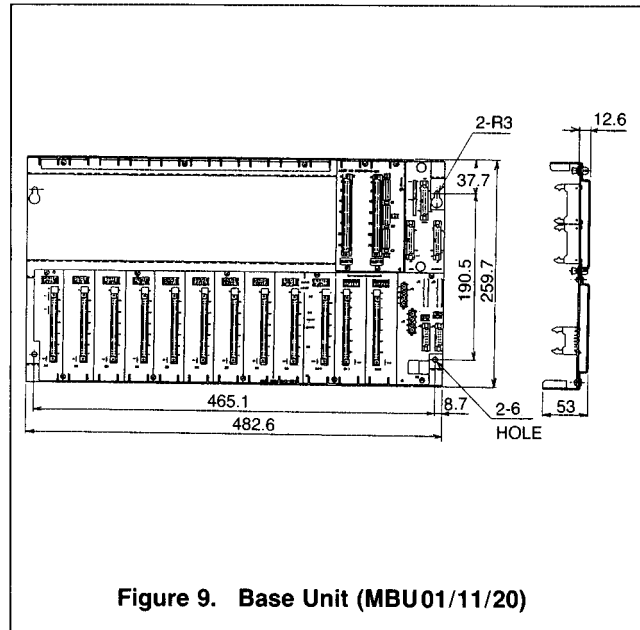

Figure 9. Base Unit (MBU01/11/20)

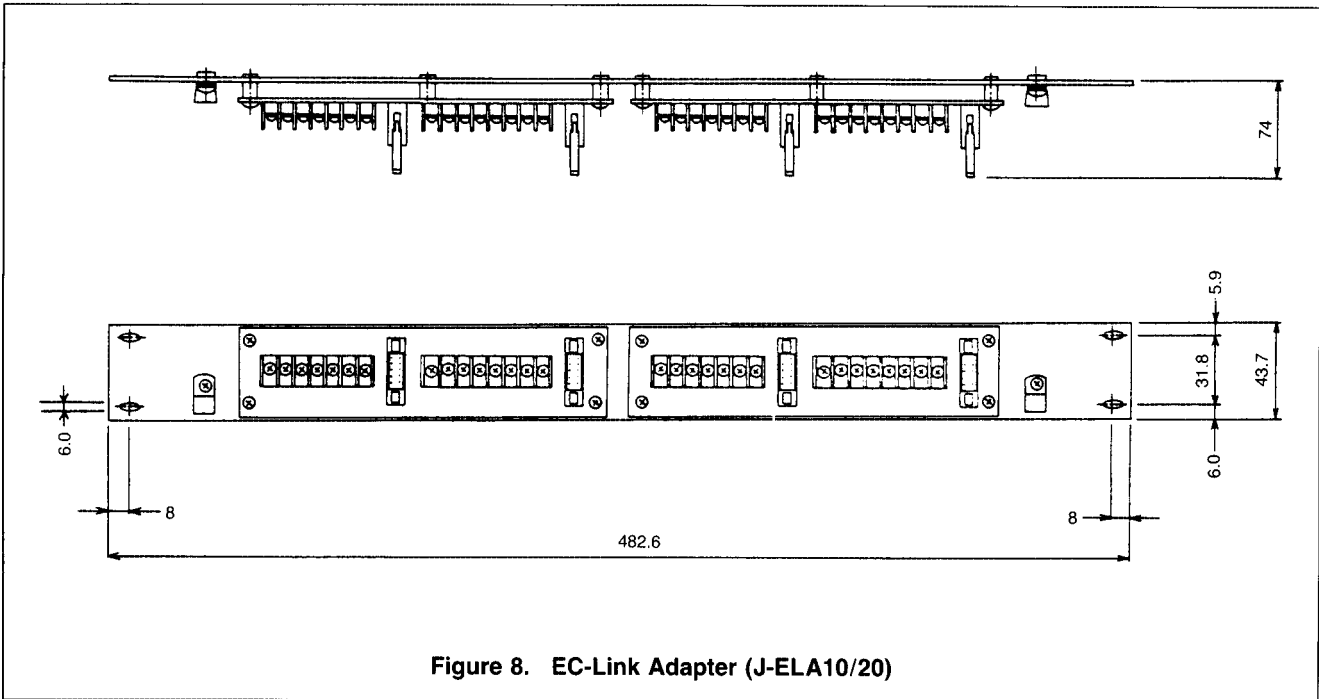
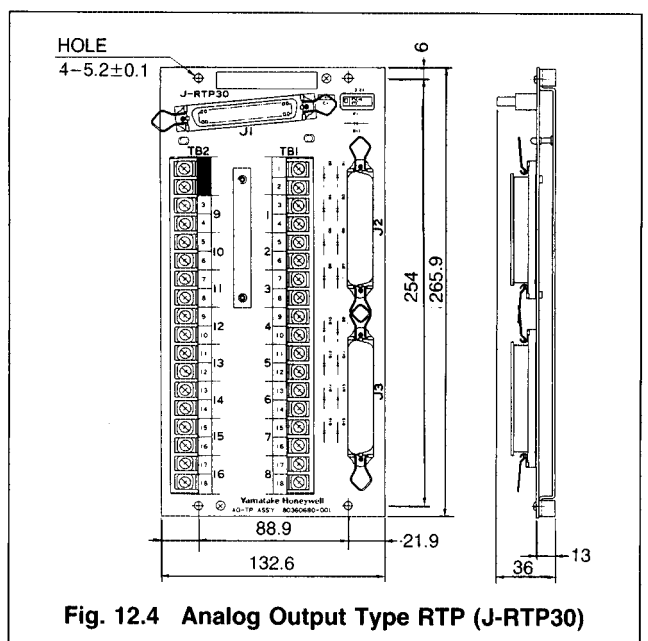
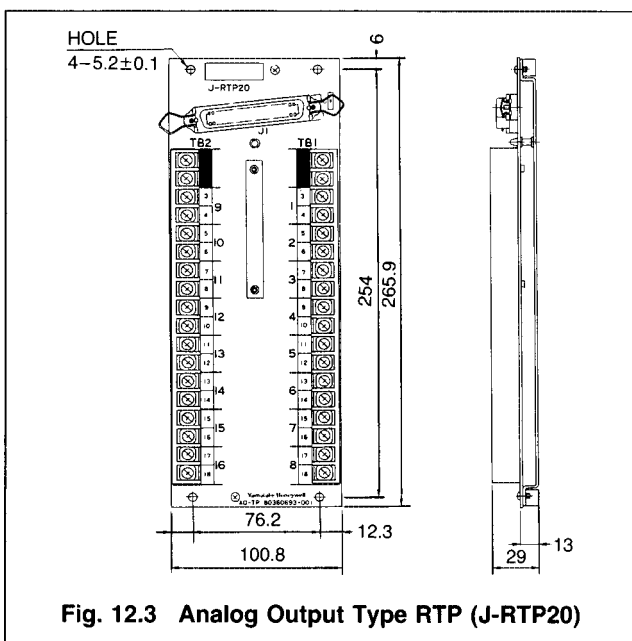
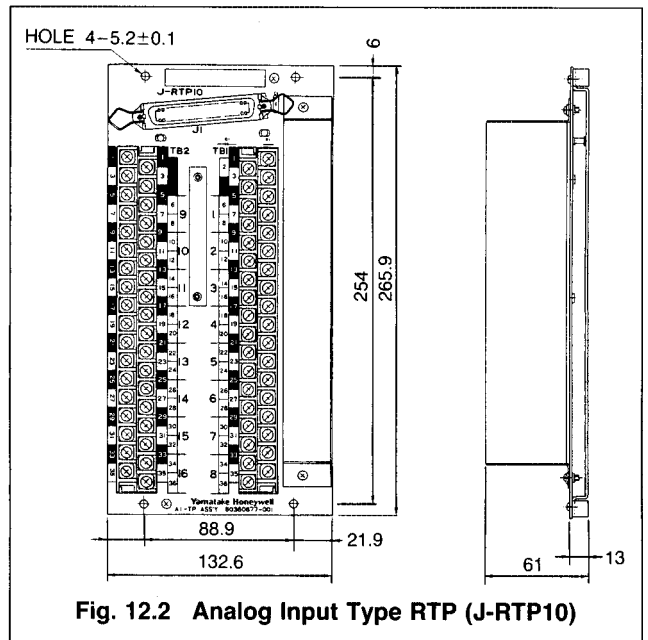
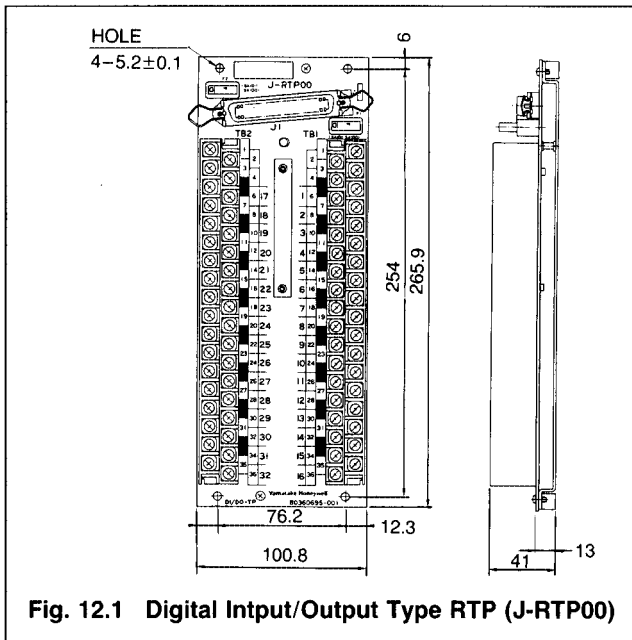
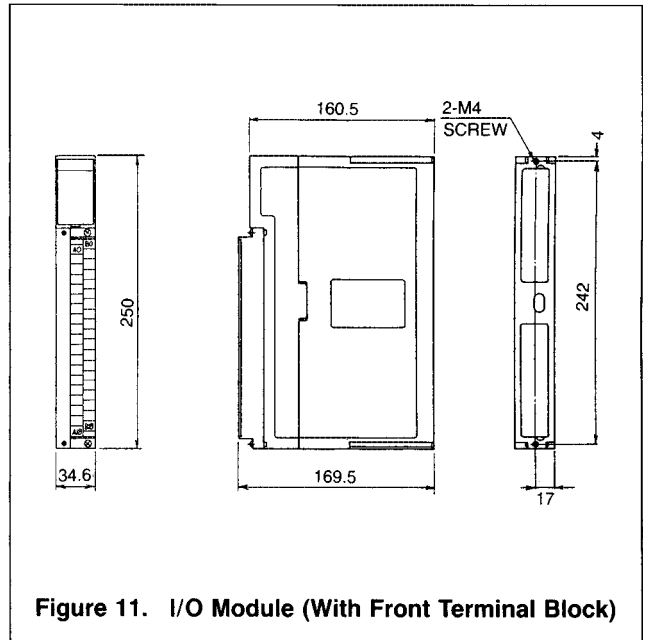
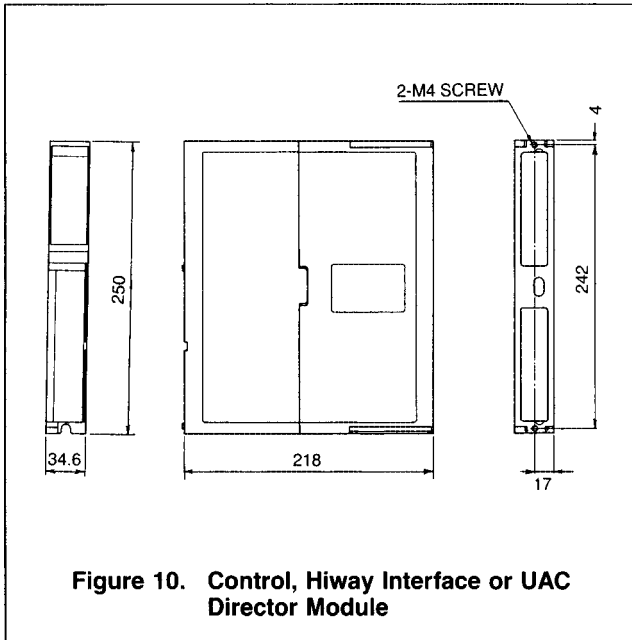

Figure 8. EC-Link Adapter (J-ELA10/20)



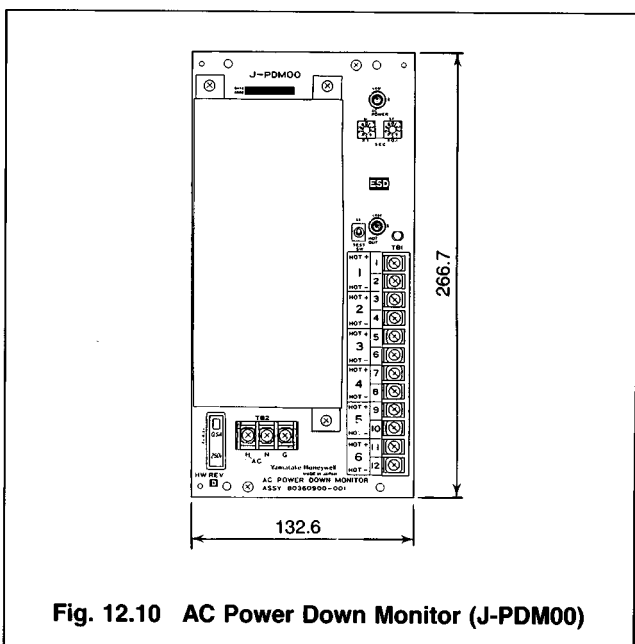
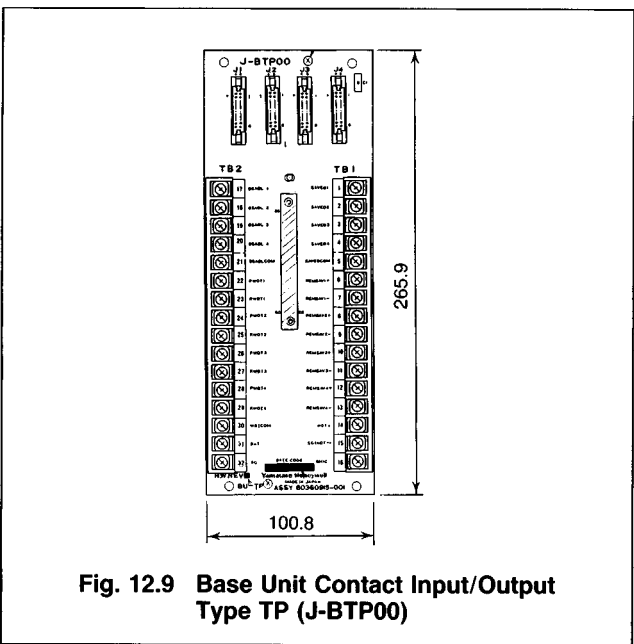
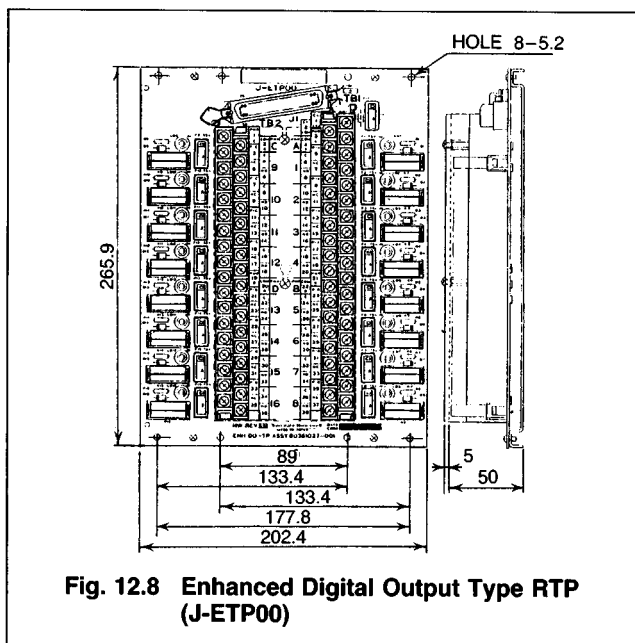
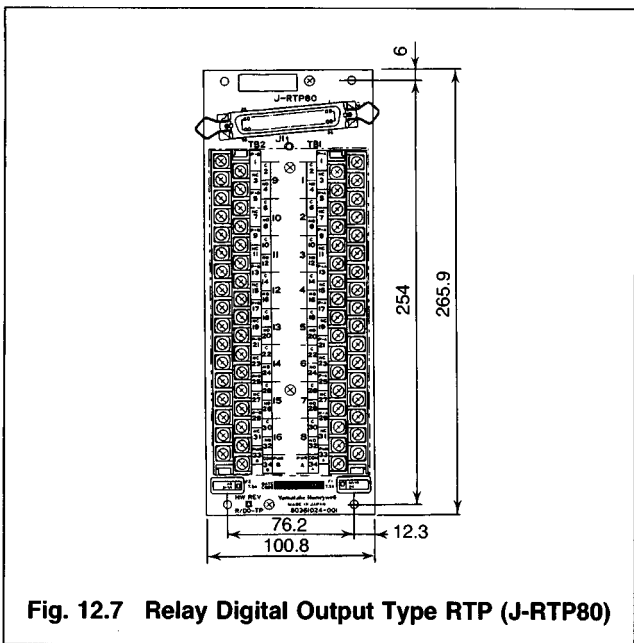
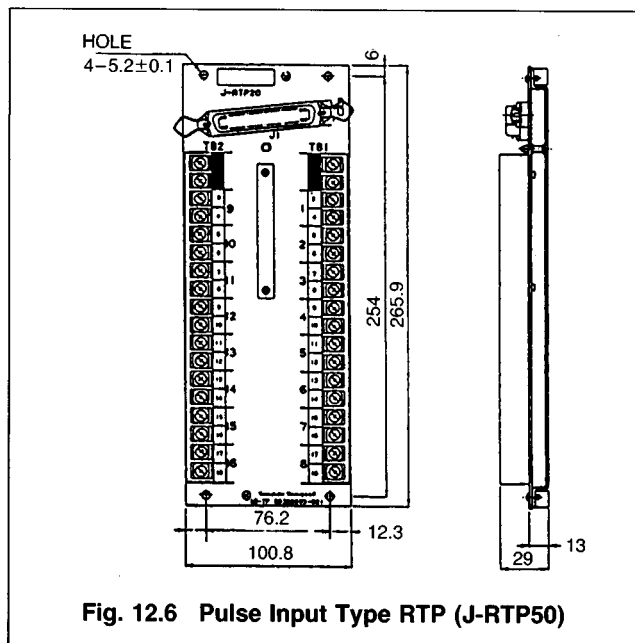
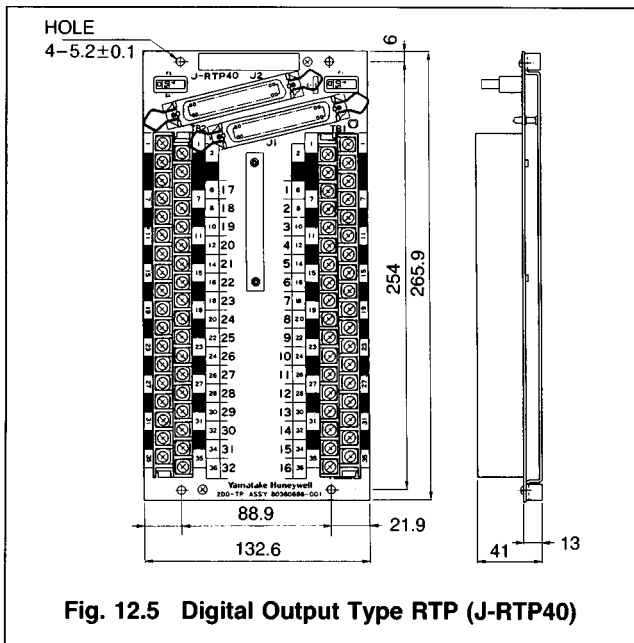

Figure 12. Dimensions of Remote Terminal Panels

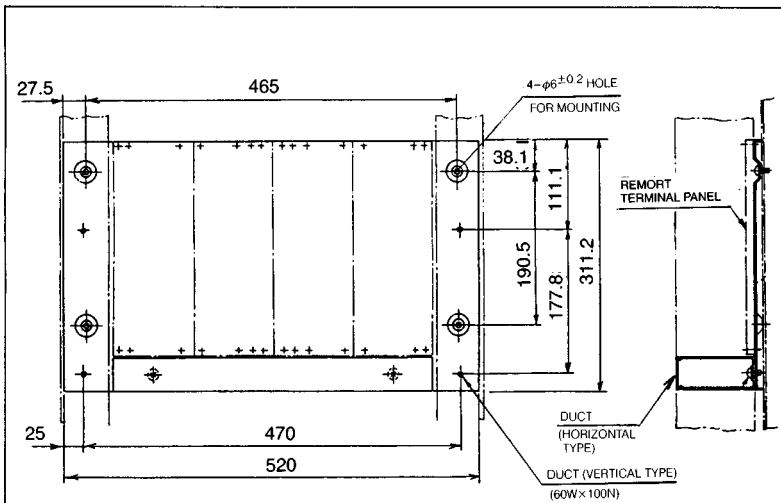

Fig. 13 Terminal Panel Supporter (J-TPX10)

Note) The J-TPX10 is provided when mounting the terminal panel on cabinets other than the TDC 3000 standard cabinet, including the mounting framework and the duct for field wiring.

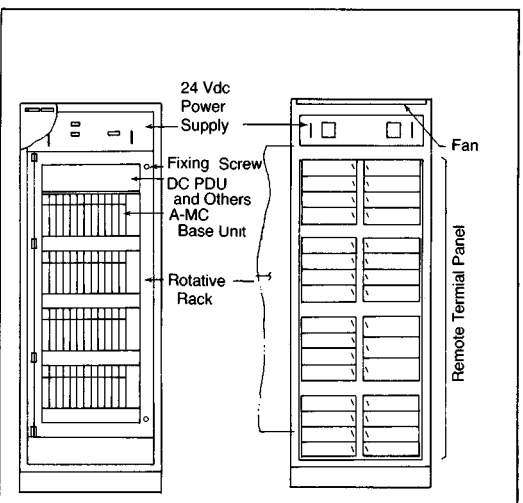

Fig. 14 System Installed in Cabinet

Specification

Table 6. Environmental Conditions

Item		Reference Band	Normal Band	Operative Limits	Transportation Storage
Ambient Temperature	Range (°C)	25±2	10 to 40	0 to 50	-40 to +70
	Rate of Change (°C/minute)	0	0.25	1	5
Relative Humidity	(% RH)	45±5	10 to 90	5 to 90	5 to 95
Vibration	Frequency (Hz)	0	0 to 60	0 to 60	0 to 60
	Acceleration (g)	0	0.1	0.2	0.5
	Amplitude (mm p-p)	0	0.75	0.75	—
Mechanical Shock	Acceleration (g)	0	1	5	25
	Duration (msec)	0	30	30	30
Barometric Pressure	(cmHg)	53 to 78	53 to 78	53 to 78	28 to 78

* The above specifications are for the A-MC Controller as an independent unit.

Table 7. Input Power Requirements

Model No. *2	Module Name	Power Consumption mA (at 24 Vdc)	Inrush Current A (at 24 Vdc)
J-MSC10	Multifunction Control Module (MCM)	195	5
J-MHM10	Hiway Interface Module (HIM)	320	—
J-UDM00	UAC Director Module (UDM)	200	5
J-HCX00	Hiway Cable Interface (HCIM)	120	8
J-HAM10/HAF10	Analog Input Module (HAIM)	130	3
J-HMM10/HMF10	High Level Analog Multiplexer Module (HMUXM)	60	3
J-STM00/STF00	Smart Transmitter Digital Communication Module (STDCM)	130	3
J-AOM10/AOF10	Analog Output Module (AOM)	480*1	3
J-DIM00/DIF00	Digital Input Module (DIM)	60	3
J-DIM10/DIF10	48V Digital Input Module (DIM)	60	3
J-DOM00/DOF00	Digital Output Module (DOM), 16 points	60	3
J-DOM10/DOF10	Digital Output Module (DOM), 32 points	90	3
J-DOM20/DOF20	Relay Digital Output Module (DOM)	250	3
J-PIM00/PIF00	Pulse Input Module (PIM)	130	3

Note. *1) The value includes the output currents of the 16 output points (20 mA per point). Other input/output modules do not include externally supplied I/O power.

*2) On model numbers of I/O modules, J-□□□□□ is for the Remote Terminal Panel and J-□□□□□ is for a module with the Front Terminal Block.

Table 8. Performance Specifications

	Item	Specification
Analog Input	Module Types	J-HAM10/HAF10, J-HMM10/HMF10
	Points/Module	16
	Points/Controller	32
	Input Circuit	Differential, non-isolated, with redundant multiplexer
	Input Signal	1 to 5 Vdc
	Input Range (FS)	0.726 to 5.276 Vdc (–6.9 to 106.9%)
	A/D Conversion Resolution	0.01% (14-bit A/D conversion)
	Conversion Reference Accuracy	±0.1% FS
	Effect of Temperature Coefficient Due to Offset	±0.005%/°C
	Effect of Supply Voltage	±0.01%/V (change from nominal 24 Vdc)
	Common Mode Voltage	–3 Vdc to +5.5 Vdc
	Common Mode Rejection Ratio (CMRR)	60 dB min.
	Scan Frequency per Point	0.5 sec.
	Transmitter Power Supply	Can be supplied to each point via RTP (A-MC Power)–(1.5+0.01ℓ)V, ℓ≤100 m (ℓ: I/O cable length) A-MC power is 25.5 Vdc when J-STX type TDC power supply.
	Transmitter Power Current Limiter	Can be limited to each point by AI adapter
Limit Current when Short-Circuit	30±3 mA (24 Vdc)	
Input Impedance	1 MΩ or greater (When system power is OFF) 5 MΩ or greater (When system power is ON)	
Automatic Drift Compensation	Available for offset (zero point) and gain (span) during running mode	
Analog Output	Module Types	J-AOM10/AOF10
	Points/Module	8 (when used as an optional I/O module) 16 (when used in OUT slot)
	Points/Controller	72 (maximum)
	Output Signal	4 to 20 mA DC (0 to 100%)
	Output Range	2.9 to 21.1 mA (–6.9 to 106.9%)
	Output Accuracy	±0.35% FS
	Resolution	±0.05% FS (12-bit D/A conversion)
	Effect of Temperature Coefficient Due to Offset	±0.025% FS/°C
	Effect of Supply Voltage	±0.1% FS/V (change from nominal 24 Vdc)
	Maximum Load	750 ohms (at 21.5 Vdc)
	Security	Output current loopback check— when MCM is abnormal, the output is held.
Scan Frequency per Point	0.5 sec.	
Smart Field Device Input	Module Types	J-STM00/STF00
	Points/Module	16 (up to 8 smart field devices)
	Points/Controller	32 (up to 16 smart field devices)
	Input Circuit	Differential input type, nonisolation, redundant multiplexer circuit
	Input Signal	1 to 5 Vdc
	Input Range (FS)	0.726 to 5.276 Vdc (–6.9 to 106.9%) (in analog input)
	A/D Conversion Resolution	0.01% FS (14-bit A/D conversion) (in analog input)
	Conversion Reference Accuracy	±0.1% FS (in analog input)
	Effect of Temperature Coefficient Due to Offset	±0.005%/°C (in analog input)
	Effect of Supply Voltage	±0.01%/V (change from nominal 24 Vdc)
	Communication Protocol	Yamatake-Honeywell DE (Digital Enhancement) Protocol
	Transmission Rate	216.478BPS±1%

	Item	Specification.
Smart Field Device Input (cont'd)	Transmission Data	Status flag, floating point data <ul style="list-style-type: none"> • Transmitter diagnosis status • Abnormality processing configuration (PV: burnout high, burnout low or final good value holding, control: output holding, manual mode or control continued) • PV configuration: single range, dual range, or multivariable • First process variable (PV), or second variable (SV)
	PV Value Accuracy (in DE communication)	Same accuracy as transmitter (for example, 0.075% of indication for differential pressure transmitter ST3000 (equivalent to JTD220))
	Allowable Common Mode Voltage	-3 to +5.5 Vdc
	Common Mode Rejection Ratio (CMRR)	60 dB or greater
Digital Input	Module Types	J-DIM00/DIF00
	Points/Module	32
	Points/Controller	256 (maximum)
	Isolation	Optical Isolation with photocoupler
	Common	16 points/common
	Input Circuit	Bidirectional (current source/current sink) (16 points selectable)
	Input Power Supply	Nominal: 24 Vdc Operable Range: 15 to 30 Vdc
	• When FTB is used	Nominal: 24 Vdc Operable Range: (15+0.015ℓ)~30 Vdc
	• When RTB is used	ℓ ≤ 100 m (ℓ: I/O cable length)
	Input Signal	ON: 13 Vdc or greater, or 3 mA or greater OFF: 4 Vdc or greater, or 0.7 mA or greater
	Input Impedance	4.2 kΩ
Scan Frequency per Point	0.5 sec.	
Detectable Signal Pulse Width	Status input: 0.5 sec. } Latched input: 30 msec. } 16 points Selectable	
Response Time	10 msec.	
48 V Digital Input	Module Types	J-DIM10/DIF10
	Points/Module	32
	Points/Controller	256 (maximum)
	Isolation	Photocoupler
	Common	16 points
	Input Circuit	Bidirectional (current source/current sink) (16 point selectable)
	Input Power Voltage (for FTB)	Rating: 48 Vdc, operating range: 38 to 58 Vdc
	Input Power Voltage (for RTP)	Rating: 48 Vdc, operating range: (38+0.015 ℓ) Vdc to 58 Vdc
		ℓ ≤ 100 m, ℓ: I/O cable length
	Input Signal	ON: 35 Vdc or greater, or 3 mA or greater OFF: 4 Vdc or greater, or 1.5 mA or less
	Input Impedance	11.3 kΩ
	Scan Frequency (per point)	0.5 sec.
	Detectable Signal Pulse Width	0.5 sec. (status input) } 30 msec. (latch input) } 16 points selectable
Response Time	10 msec.	
Dielectric Strength	1500 Vac for 1 minute (between EXCOM and SG, between EXCOMA and EXCOMB)	

	Item	Specification
Digital Output	Module Types	Solid-state outputs: J-DOM00/DOF00, D-DOM10/DOF10
	Points/Module	16 (DOM00/DOF00), 32 (DOM10/DOF10)
	Points/Controller	144 (maximum)
	Scan Frequency per Point	0.5 sec.
	Output Functions*	Latched (status) output or timed (one-shot) output, 8 points selectable
	DO Pulse Width	25 msec. to 1 sec. Resolution: 25 msec. Can be specified per 8 points.
	Security	Output held or unpowered state with MCM failure. (Selectable per module) *: Timed output not available for outputs 17 to 32 of J-DOM10/DOF10.
	Isolation	Optical isolation with photocoupler
	Common	16 points/common
	Output Load Voltage	Open collector
	• When FTB is used	Nominal: 24 Vdc, Operable Range: 15 to 30 Vdc
	• When RTB is used	Nominal: 24 Vdc, Operable Range: (15+0.015l')~30 Vdc l' ≤ 100 m (l': I/O cable length)
	Load Current	I ≤ 4 A (I: Maximum load current per common) 0.5 A max. (per point) 4 A max. (per common)
	Peak Load Current	1 A
Off Peak Current	0.1 mA or less (at 30 Vdc)	
ON Voltage (when front terminals used)	1.5 V or less (at 0.5 A)	
ON Voltage (when RTP is used: Terminals between RTP load and COM)	1.5+(i+l/8)×0.11l' (V) where i: Maximum load current (≤0.5 A) per one objective channel l: Maximum load current (≤4 A) per common l': I/O cable length (≤ 50 m) Example: when l' = 10 cm and load current of each of the points is 0.1 A $1.5+(0.1+\frac{0.1 \times 1.6}{8}) \times 0.11 \times 10 = 1.83 \text{ (V)}$	
Relay Digital Output	Module Types	J-DOM20/DOF20
	Points/Module	16
	Points/Controller	128 (maximum)
	Scan Frequency	0.5 sec.
	Output Types	Latch (status) output or pulse (one-shot) output 8 points output
	DO Pulse Width	8 points selectable, 25 msec. to 1 sec., 25 msec. resolution
	Security	Output holding at MCM abnormality, or de-energizing state (module selectable)
	Contact Specification	<ul style="list-style-type: none"> • For RTP80, or I/O cable: Transfer output (C-contact) × 16 channels • For FTB: Transfer × output (C-contact) × 4 channels, Make (A-contact) × 12 channels • For RTP, or I/O cable: 250 Vac, 1.5 A (resistive load) 125 Vac, 1.5 A (resistive load)
Contact Ratings		

	Item	Specification
Relay Digital Output (cont'd)	Contact Ratings (cont'd)	30 Vdc, 1.5 A (resistive load) 125 Vdc, 0.1 A (resistive load) 250 Vac, 1.5 A (inductive load, power factor 0.4) 125 Vac, 1.5 A (inductive load, power factor 0.4) 30 Vdc, 1.0 A (inductive load, L/R=100 ms) 125 Vdc, 0.2 A (inductive load, L/R=7 ms) 125 Vdc, L/R=100 ms cannot be used. • For FTB: 250 Vac, 3.0 A (resistive load) 125 Vac, 3.0 A (resistive load) 30 Vdc, 3.0 A (resistive load) 125 Vdc, 0.1 A (resistive load) 250 Vac, 1.5 A (inductive load, power factor 0.4) 125 Vac, 1.5 A (inductive load, power factor 0.4) 30 Vdc, 1.0 A (inductive load, L/R=100 ms) 125 Vdc, 0.2 A (inductive load, L/R=7 ms) 125 Vdc, L/R=100 ms cannot be used.
	Maximum Contact Open-Close Voltage	250 Vac, 125 Vdc
	Maximum Contact Open-Close Voltage/Current	5 Vdc/10 mA Between contacts: 1500 Vac for 1 minute Between contact and SG: 1500 Vac for 1 minute
	Operating Time	10 msec
	Recovery Time	10 msec
Extended Digital Output	Module Type	J-ETP00
	Do Module used	J-DOM00
	Points/Terminal Panel	16
	Contact Specification	Transfer output (C-contact) × 16 channels (1 contact/channel)
	Contact Ratings	250 Vac, 5.0 A (resistive load) 125 Vac, 5.0 A (resistive load) 30 Vdc, 5.0 A (resistive load) 125 Vdc, 0.1 A (resistive load) 250 Vac, 2.0 A (inductive load, power factor 0.4) 125 Vac, 2.0 A (inductive load, power factor 0.4) 30 Vdc, 1.0 A (L/R=100 ms) 125 Vdc, 0.1 A (L/R=100 ms)
	Maximum Contact Open-Close Voltage	250 Vac, 125 Vdc
	Minimum Contact Open-Close Voltage/Current	50 Vdc/10 mA
	Dielectric Strength	Between contacts: 1500 Vac for 1 minute Between contact and SG: 1500 Vac for 1 minute
	Operating Time	10 msec
	Recovery Time	10 msec
	Excitation Power Voltage	24 Vdc ± 6 Vdc
Excitation Current	350 mA maximum (per ETP in 24 Vdc)	
Low-Speed Pulse (Counter) Inputs	Module Type	J-DIM00/DIF00/DIM10/DIF10
	Points/Module	8
	Points/Controller	64 (maximum)
	Pulse Rate	0 to 15Hz
	ON/OFF Period	ON: 33 msec. or greater OFF: 33 msec. or greater
	Scan Frequency per Point	0.5 sec.

	Item	Specification
High-Speed Pulse (Counter) Inputs	Module Type	J-PIM00/PIF00
	Points/Module	8
	Points/Controller	64 (maximum)
	Isolation	Optical isolation with photocoupler
	Common	8 points/common
	Input Circuits	Current source type
	Input Power Supply	
	• when FTB is used	Nominal: 24 Vdc Operable Range: 15 to 30 Vdc
	• when RTP is used	Nominal: 24 Vdc Operable Range: (15+0.015ℓ) to 30 Vdc ℓ ≤ 100 m (ℓ: I/O cable length)
	Input Signals	Contact signals or open collector signals ON: 13 Vdc or greater, or 3 mA or greater OFF: 5 Vdc or greater, or 1.2 mA or greater
	Pulse Rate	5 kHz maximum
Input Filter Constants	A) 10 μs (up to 5 kHz) B) 10 ms (up to 20 Hz) Selectable for each input point	
ON/OFF Time	A) ON: 0.1 ms or greater, OFF: 0.1 ms or greater (When filter A is used) B) ON: 25 ms or greater, OFF: 25 ms or greater (When filter B is used)	
Scan Period	0.5 sec.	

Table 9. Auxiliary Terminal Specification

Type	Item	Specification																
Base Unit Terminal	Model No.	J-BTP00																
	Number of Support Units/Terminal	4 A-MCs/terminal																
	Number of points/terminal	Digital outputs: 16 <ul style="list-style-type: none"> • Control module CPU reset output (WDT): 8 (primary/secondary) • Control module backup state (SAVED): 4 • UAC disable state (DSABL): 4 Digital input: 6 <ul style="list-style-type: none"> • Remote save input (REMSNAV): 4 • Hot restart demand input (HOT-RESTART): 1 • Computer shed input (BMIC): 1 																
	Digital Output <ul style="list-style-type: none"> • Output Circuit Configuration • Isolation • Common • External Power • Load Current • Peak Current • Leak Current • Voltage at Transistor on State • Dielectric Strength Digital Input <ul style="list-style-type: none"> • Input Circuit • Input Signal Range 	Open-collector output Optical isolation WDT signal, SAVED signal, DSABL signal: same common for emitter (-) side Voltage range: +15 to 30 Vdc (recommended: 24 V) 0.5 A maximum 1.0 A maximum 0.1 mA maximum (at 40 Vdc) 1.0 V maximum (at 0.5 A) 1500 Vdc Photocoupler Input <table border="1" style="margin-left: 20px;"> <thead> <tr> <th></th> <th>REMSAV signal</th> <th>HOT-RESTART signal</th> <th>BMIC signal</th> </tr> </thead> <tbody> <tr> <td>Resistance at ON state</td> <td>2 KΩ or less</td> <td>1 KΩ or less</td> <td>100 Ω or less</td> </tr> <tr> <td>Resistance at OFF state</td> <td>1 MΩ or greater</td> <td>1 MΩ or greater</td> <td>1 MΩ or greater</td> </tr> <tr> <td>Input impedance</td> <td>2 KΩ</td> <td>4.5 KΩ</td> <td>430 Ω</td> </tr> </tbody> </table>		REMSAV signal	HOT-RESTART signal	BMIC signal	Resistance at ON state	2 K Ω or less	1 K Ω or less	100 Ω or less	Resistance at OFF state	1 M Ω or greater	1 M Ω or greater	1 M Ω or greater	Input impedance	2 K Ω	4.5 K Ω	430 Ω
	REMSAV signal	HOT-RESTART signal	BMIC signal															
Resistance at ON state	2 K Ω or less	1 K Ω or less	100 Ω or less															
Resistance at OFF state	1 M Ω or greater	1 M Ω or greater	1 M Ω or greater															
Input impedance	2 K Ω	4.5 K Ω	430 Ω															
Power down Monitor	Model No.	J-PDM00																
	Number of Supporting Units	40 A-MCs maximum																
	Number of Inputs	1																
	Input Signal	100 Vac, 50/60 Hz																
	Number of Outputs	6																
	Output Signal <ul style="list-style-type: none"> • ON Voltage • OFF Leak Current • Isolation • Output Holding Setting of Interruption Judgement Time Accuracy of Interruption Judgement Time	Transistor output (30 V, 600 mA), on at interruption detection 2 V or less 0.1 mA or less Photocoupler isolation 3.5 \pm 1 sec. (from acknowledgement of startup) 0.6 to 9.9 sec. (can be set by 0.1 sec.) \pm 0.1 sec.																

Table 10. Communication Specifications**(1) Highway internal cable**

Item	Specification
Maximum Length	40 m
Maximum Drop Number (number of HIMs)	32/HCIM
Signal Level	RS485: Balance (differential) type, nonisolation
Communication Speed	250K bits/sec
Maximum Common Mode Voltage	+12 V, -7 V
Terminal Resistance	150Ω (depending resistor on the Base Unit)

(2) EC-Link

Item	Specification
Maximum Length	100 m
Number of A-MCs	Up to 16
Maximum Drop Number	32
Signal Level	RS485: Balance (differential) type, nonisolation
Communication Speed	500K bits/sec
Maximum Common Mode Voltage	+12 V, -7 V
Terminal Resistance	75Ω: with diode (depending on the ECLT)

Table 11. Weight of Modules

Number	Type	Item	Weight	Number	Type	Item	Weight
1	J-MBU01	Base unit	2.75	19	J-ACC00	Accessory module	0.30
2	J-MBU11	UAC base unit	2.75	20	J-FTB00	Front terminal	0.15
3	J-MBU20	I/O base unit	2.75	21	J-RTP00	Remote terminal panel	0.80
4	J-BCA00	Base unit contact input/output adaptor	0.11	22	J-RTP10	Remote terminal panel	1.20
5	J-MS010	Control module	1.25	23	J-RTP20	Remote terminal panel	0.60
6	J-MHM10	Hiway interface module	1.10	24	J-RTP30	Remote terminal panel	0.80
7	J-HCX00	Hiway cable interface module	0.75	25	J-RTP40	Remote terminal panel	0.95
8	J-UDM00	UAC director module	0.95	26	J-RTP50	Remote terminal panel	0.60
9	J-HAM10	Analog input module	0.85	27	J-RTP80	Remote terminal panel	0.80
10	J-HMM00	Analog multiplexer module	0.55	28	J-AAU00	AI adaptor unit	0.07
11	J-AOM10	Analog output module	0.85	29	J-PDM00	Power down monitor	1.20
12	J-DIM00	Digital input module	0.60	30	J-BTP00	Base unit contact input/output terminal panel	0.65
13	J-DIM10	48V Digital input module	0.60	31	J-PDP00	Distribution panel	0.72
14	J-DOM00	Digital output module	0.60	32	J-ETP00	Extended digital output terminal panel	1.60
15	J-DOM10	Digital output module	0.60	33	J-ELA00	EC-Link adaptor	0.48
16	J-DOM20	Relay digital output module	0.60	34	J-ELA10	EC-Link adaptor	0.34
17	J-PIM00	High speed pulse input module	0.70	35	J-ELA20	EC-Link adaptor	0.40
18	J-STM00	Smart transmitter digital communication module	0.80				

Note) The weight of the J-XXFXX is calculated by adding the equivalent J-XXMXX to the weight of the J-FTB00.

Specifications are subject to change without notice.

YAMATAKE

Yamatake Corporation

Totate International Building
2-12-19 Shibuya
Tokyo 150-8316
Tel : 81-3-3486-2506
Fax : 81-3-3486-2503

Yamatake-SIC Control Systems Co., Ltd.	: China	86-10-6326-9844/55
Shanghai Yamatake Jinshan Control Instruments Co., Ltd.	: China	86-21-5793-5334
Yamatake (Thailand) Co., Ltd.	: Thailand	66-2-210-0900~7
Yamatake Philippines, Inc.	: Philippines	63-2-817-6452
PT. Yamatake Berca Indonesia	: Indonesia	62-21-230-5537/5539
Yamatake Controls Singapore Pte. Ltd.	: Singapore	65-778-5966
YCV Corporation	: U.S.A.	1-602-548-1800

Savemation

Saving through Automation

Yamatake Industrial Systems Co.,Ltd.

URL : <http://www.yamatake.co.jp/>

9809-Y/Y

This has been printed on recycled paper.