

FL2R/S Series

DC 2-wire Type Square Proximity Sensors

FEATURES

This DC 2-wire Type Square Proximity sensor Can Be Directly Connected to Programmable Controllers and N.C. Units.

Wide Range of Models Available.

- Reduced wiring costs.
- Stable sensing area displayed by setting indicator. (on N.O. output type only)
- Wide range of models available. (4/7/12/20mm, top/side, N.O./N.C.)
- High-speed response. (1.5kHz 4mm, 1kHz AT 7mm)
- Different-frequency types that are only slightly influenced by mutual interference available for all models.
- High seal capabilities. (IP67)
- Enhanced circuit protection. (surge absorption, loadshort-circuit, reverse connection)

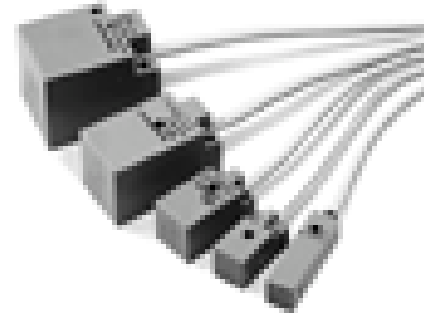

click



ORDER GUIDE

- Standard (pre-leaded) model (cord length 1m)



Actuation method	Appearance		Sensing distance	Sensing face	Operation mode	Setting indication	Catalog listing
	Sensor package style	Dimensions					
High-frequency oscillating type (unshielded)		12 × 12 × 45	4mm	Top	N.O.	○	FL2S-4J6HD
					N.C.		FL2S-4K6H
		15 × 15 × 32	4mm	Side	N.O.	○	FL2S-4J6SD
					N.C.		FL2S-4K6S
		20 × 20 × 38	7mm	Top	N.O.	○	FL2R-4J6HD
					N.C.		FL2R-4K6H
		30 × 30 × 52.5	12mm	Side	N.O.	○	FL2R-4J6SD
					N.C.		FL2R-4K6S
		40 × 40 × 53	20mm	Top	N.O.	○	FL2R-12J6HD
					N.C.		FL2R-12K6H
				Side	N.O.	○	FL2R-12J6SD
					N.C.		FL2R-12K6S
			Top	N.O.	○	FL2R-20J6HD	
				N.C.		FL2R-20K6H	
			Side	N.O.	○	FL2R-20J6SD	
				N.C.		FL2R-20K6S	

Note 1: Different-frequency types also available for all models. The catalog number of different-frequency types are appended with the letters “-F”. Example: Different-frequency type of **FL2R-4J6HD** is expressed as **FL2R-4J6HD-F**.

“Different-frequency type” is a type having an oscillation frequency different to that of the standard type to reduce the influence of mutual interference. Select this type when mounting two or more proximity sensors close to each other.

Note 2: Bend-resistant cord type “-R” are also available. For details, contact your nearest Yamatake dealer.

● Pre-leaded connector model (cord length 30cm)

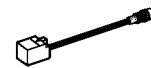
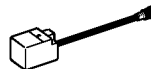
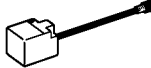
Actuation method	Appearance		Sensing distance	Sensing face	Operation mode	Setting indication	Catalog listing
	Sensor package style	Dimensions					
High-frequency oscillating type (unshielded)		12 × 12 × 45	4mm	Top	N.O.	○	FL2S-4J6HD-CN03
					N.C.		FL2S-4K6H-CN03
		15 × 15 × 32	4mm	Side	N.O.	○	FL2S-4J6SD-CN03
					N.C.		FL2S-4K6S-CN03
		20 × 20 × 38	7mm	Top	N.O.	○	FL2R-4J6HD-CN03
					N.C.		FL2R-4K6H-CN03
		30 × 30 × 52.5	12mm	Side	N.O.	○	FL2R-4J6SD-CN03
					N.C.		FL2R-4K6S-CN03
		40 × 40 × 53	20mm	Top	N.O.	○	FL2R-7J6HD-CN03
					N.C.		FL2R-7K6H-CN03
				Side	N.O.	○	FL2R-7J6SD-CN03
					N.C.		FL2R-7K6S-CN03
			Top	N.O.	○	FL2R-12J6HD-CN03	
				N.C.		FL2R-12K6H-CN03	
			Side	N.O.	○	FL2R-12J6SD-CN03	
				N.C.		FL2R-12K6S-CN03	
			Top	N.O.	○	FL2R-20J6HD-CN03	
				N.C.		FL2R-20K6H-CN03	
			Side	N.O.	○	FL2R-20J6SD-CN03	
				N.C.		FL2R-20K6S-CN03	

Note 1: Different-frequency types also available for all models. The catalog number of different-frequency types are appended with the letters “-F”.
 Example: Different-frequency type of **FL2R-4J6HD-CN03** is expressed as **FL2R-4J6HD-CN03F**.
 “Different-frequency type” is a type having an oscillation frequency different to that of the standard type to reduce the influence of mutual interference. Select this type when mounting two or more proximity sensors close to each other.

SPECIFICATIONS

Item	Catalog listing			
	FL2S-4□6□(-CN03) FL2R-4□6□(-CN03)	FL2R-7□6□(-CN03)	FL2R-12□6□(-CN03)	FL2R-20□6□(-CN03)
Actuation method	High-frequency oscillating type (unshielded)			
Rated supply voltage	12/24Vdc			
Rated sensing distance	4 ± 0.4mm	7 ± 0.7mm	12 ± 1.2mm	20 ± 2mm
Usable setting distance	0 to 2.8mm	0 to 4.9mm	0 to 8.4mm	0 to 14mm
Standard target object	18 × 18mm, 1mm thick iron	25 × 25mm, 1mm thick iron	40 × 40mm, 1mm thick iron	50 × 50mm, 1mm thick iron
Differential travel	15% max. of sensing distance			
Operating voltage range	10 to 30Vdc			
Leakage current	1mA max.			
Control output	Switching current: 4 to 100mA max. Voltage drop: 3.3V max., Output dielectric strength: 30Vdc			
Operating frequency	1.5kHz	1kHz	800Hz	300Hz
Hysteresis	0.05mm max.			
Temperature characteristics	±10% max. for the range of -25 to +70°C when taking +25°C as standard temperature in sensing distance			
Supply voltage characteristics	±1% max. with ±15% voltage fluctuation with rated supply voltage as standard voltage in sensing distance			
Indicator lamps	N.O. type: Operation indication: Lights (red or green) at output Setting indication: Lights (green) in stable sensing area N.C. type: Operation indication: Goes out (red) in sensing area			
Operating temperature range	-25 to +70°C			
Storage temperature range	-25 to +70°C			
Storage humidity range	35 to 95% RH			
Insulation resistance	50MΩ min. (at 500Vdc)			
Dielectric strength	500Vac, 50/60Hz for 1 minute			
Vibration resistance	10 to 55Hz, 1.5mm peak-to-peak amplitude, 2 hrs in X, Y and Z directions			
Shock resistance	490m/s ² 10 times in X, Y and Z directions			
Protection	IP67 (IEC standard)			
Weight	Approx. 40g	Approx. 50g	Approx. 110g	Approx. 160g
Circuit protection	Surge absorption, load short-circuit protection, reverse connection protection			
Wiring method	Pre-leaded connector, pre-leaded			
Case material	ABS resin			
Connector material	Housing	Polyester elastomer		
	Holder	Glass-lined polyester resin		
	Contact	Gold-plated brass		

● Installation Instructions No.: CP-UM-3119E

ABOUT SETTING INDICATION

The proximity sensor can detect objects reliably by bringing the proximity sensor close to the target object and setting the sensor at the position where the indicator lamp changes from red to green.

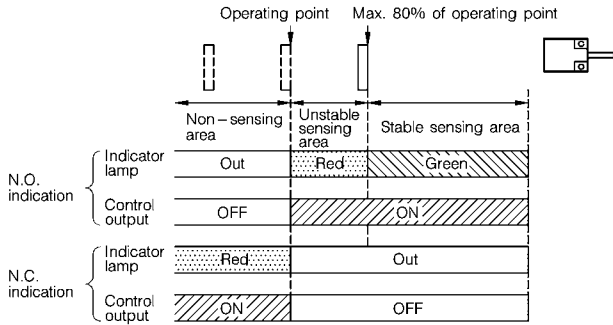

Note: When the target object is made of a different material such as aluminum, copper and stainless steel to the standard target object (iron), the setup point where the indicator lamp changes color is shorter than 80% maximum.

WIRING DIAGRAM

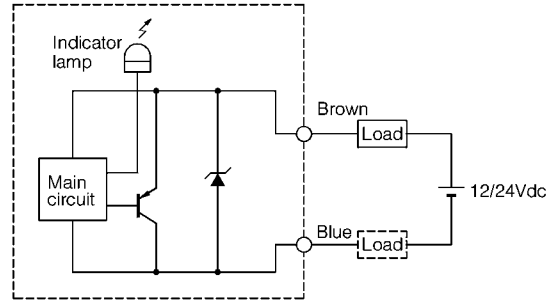

The load can be connected to either of the power supplies.

SENSING AREA DIAGRAM (typical examples)

FL2-4□6□/FL2R-7□6□

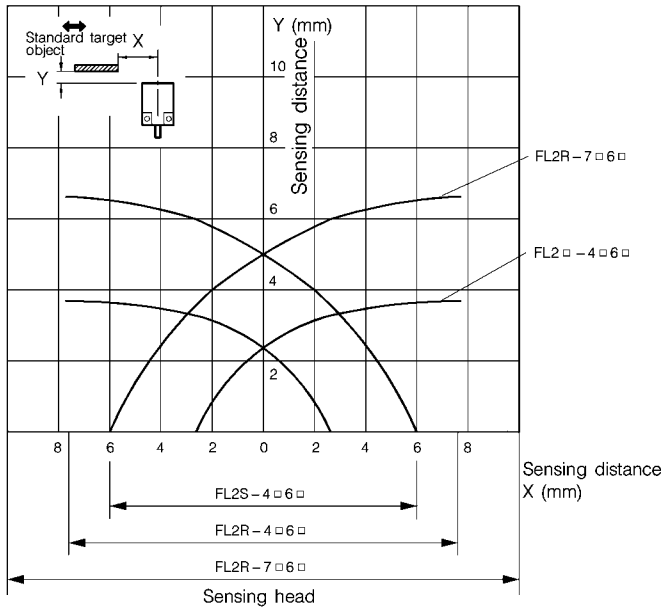

FL2R-12□6□/FL2R-20□6□

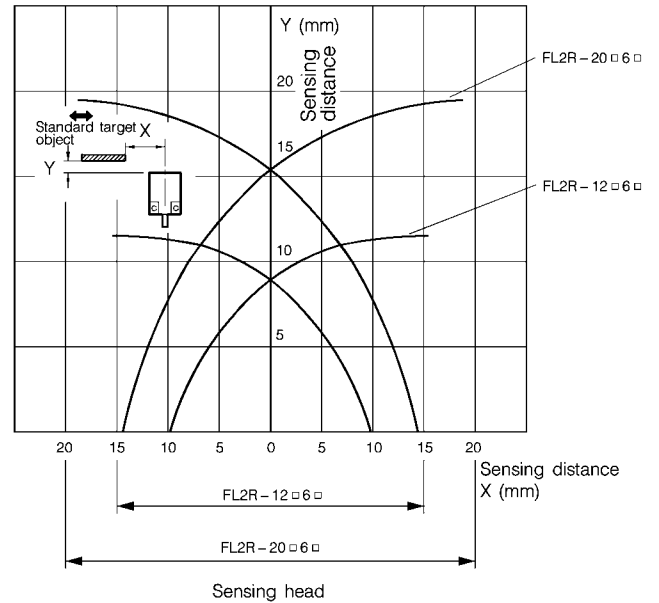

SENSING DISTANCE ACCORDING TO MATERIAL & SIZE OF OBJECT (typical examples)

FL2S-4□6□/FL2R-4□6□

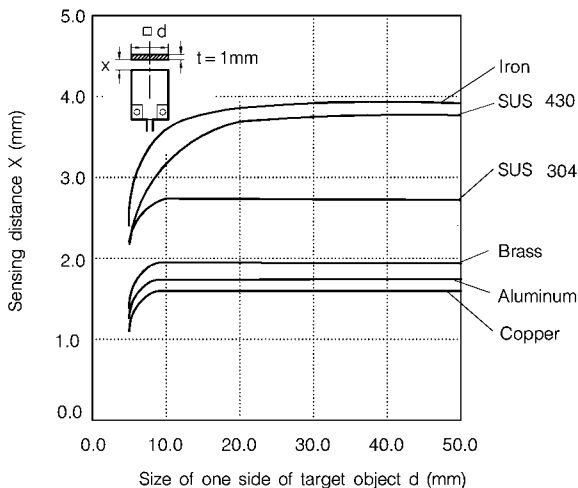

FL2R-7□6□

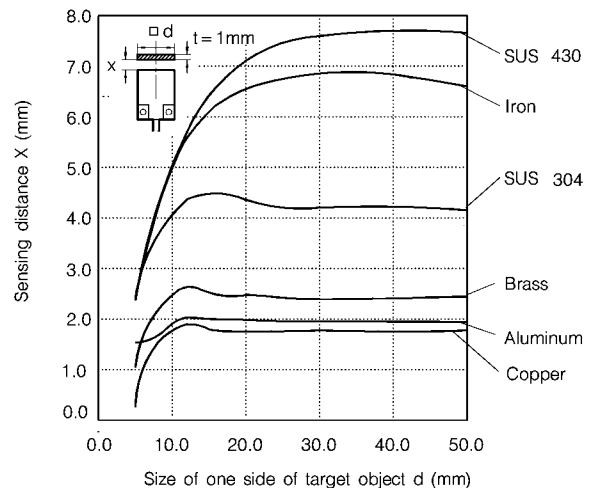

FL2R-12□6□

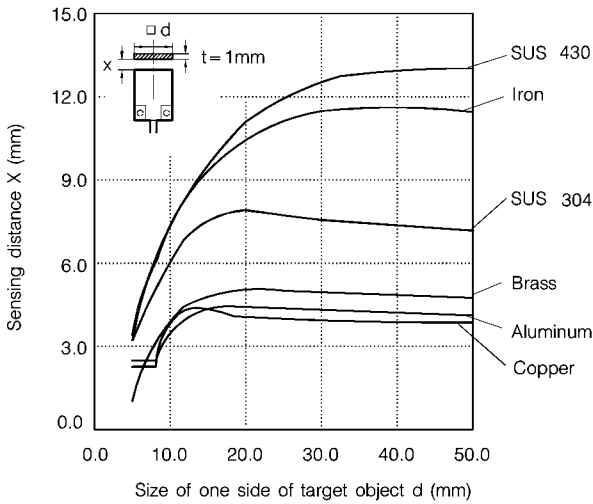

FL2R-20□6□

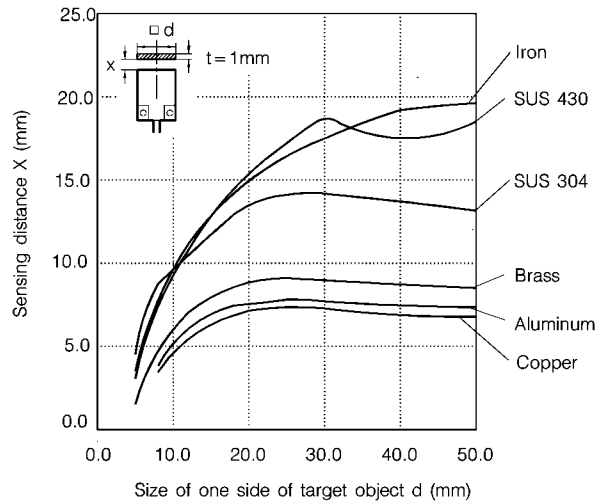

VOLTAGE DROP CHARACTERISTICS (typical example)

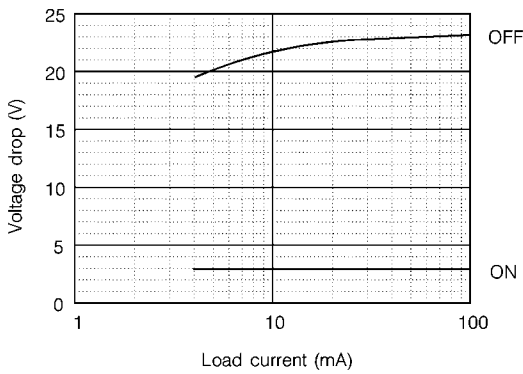

LEAKAGE CURRENT CHARACTERISTICS (typical example)

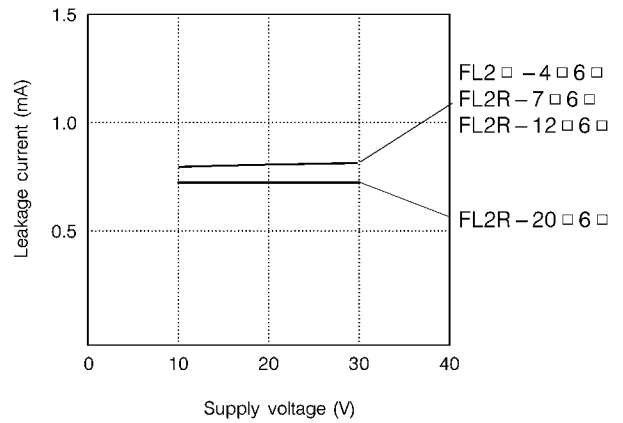

EXTERNAL DIMENSIONS

● Standard (pre-leaded) model

FL2S-4□6H□

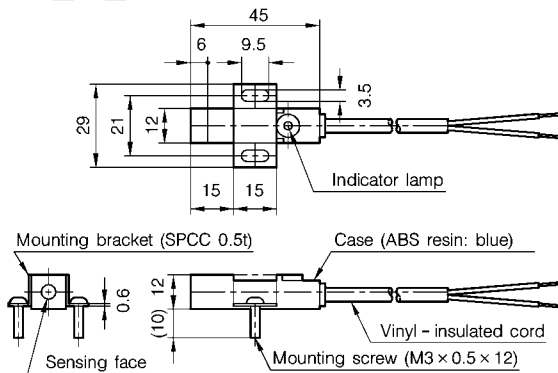

- Vinyl-insulated cord (oil-resistant: 0.3mm², 27/0.12, 2-core) 4.2mm dia.
- Note:** A mounting bracket and two mounting screws are provided.
The case color of different-frequency types "-F" is green.

FL2S-4□6S□

(unit: mm)

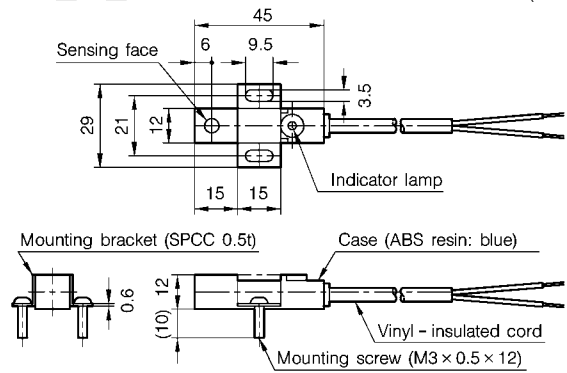

- Vinyl-insulated cord (oil-resistant: 0.3mm², 27/0.12, 2-core) 4.2mm dia.
- Note:** A mounting bracket and two mounting screws are provided.
The case color of different-frequency types "-F" is green.

FL2R-4 6H

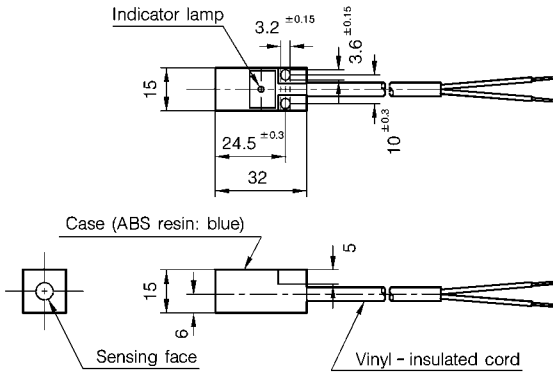

- Vinyl-insulated cord (oil-resistant: 0.3mm², 27/0.12, 2-core) 4.2mm dia. The case color of different-frequency types “-F” is green.

FL2R-4 6S

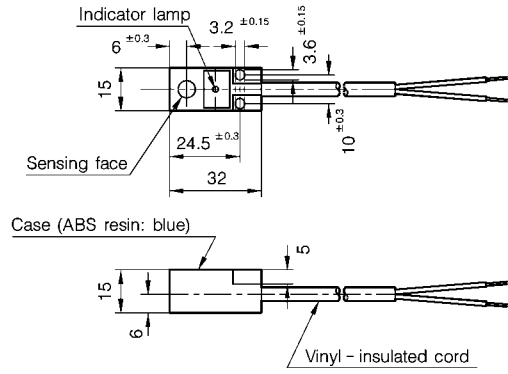

- Vinyl-insulated cord (oil-resistant: 0.3mm², 27/0.12, 2-core) 4.2mm dia. The case color of different-frequency types “-F” is green.

FL2R-7 6H

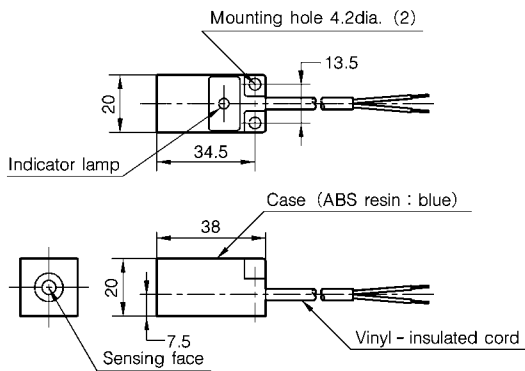

- Vinyl-insulated cord (oil-resistant: 0.3mm², 27/0.12, 2-core) 4.2mm dia. The case color of different-frequency types “-F” is green.

FL2R-7 6S

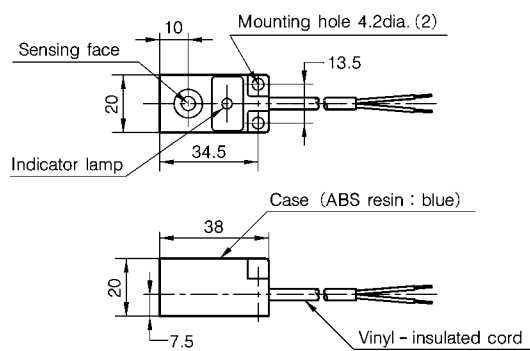

- Vinyl-insulated cord (oil-resistant: 0.3mm², 27/0.12, 2-core) 4.2mm dia. The case color of different-frequency types “-F” is green.

FL2R-12 6H

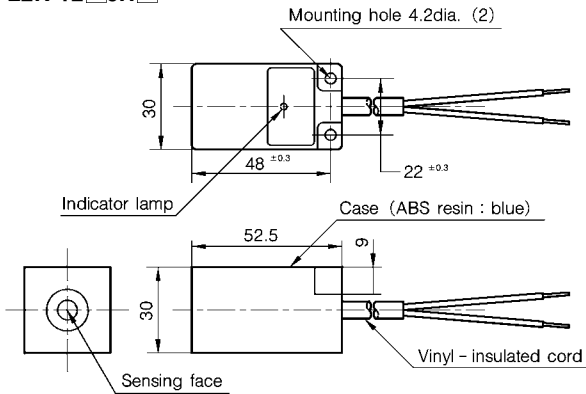

- Vinyl-insulated cord (oil-resistant: 0.5mm², 20/0.18, 2-core) 5.7mm dia. The case color of different-frequency types “-F” is green.

FL2R-12 6S

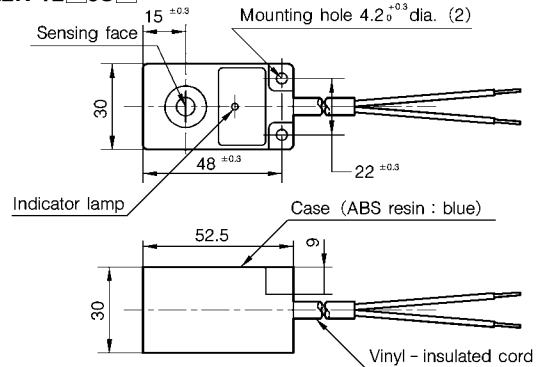

- Vinyl-insulated cord (oil-resistant: 0.5mm², 20/0.18, 2-core) 5.7mm dia. The case color of different-frequency types “-F” is green.

FL2R-20 6H

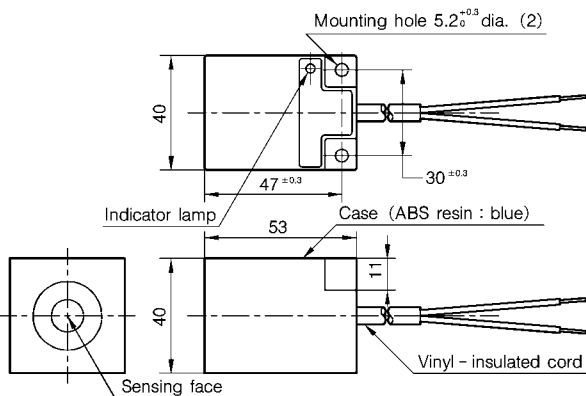

- Vinyl-insulated cord (oil-resistant: 0.5mm², 20/0.18, 2-core) 5.7mm dia. The case color of different-frequency types “-F” is green.

FL2R-20 6S

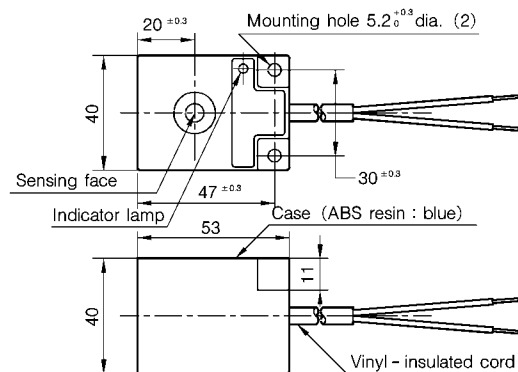

- Vinyl-insulated cord (oil-resistant: 0.5mm², 20/0.18, 2-core) 5.7mm dia. The case color of different-frequency types “-F” is green.

(unit: mm)

- Pre-leaded connector model
(connector external dimensions)

FL2□-□□6□□-CN03

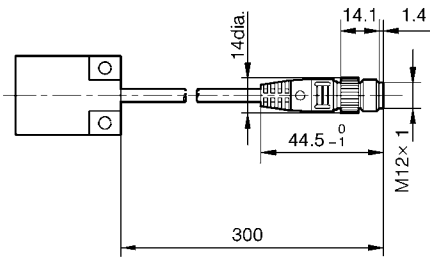

- Mounting bracket (ordered separately)

FL2-PA5

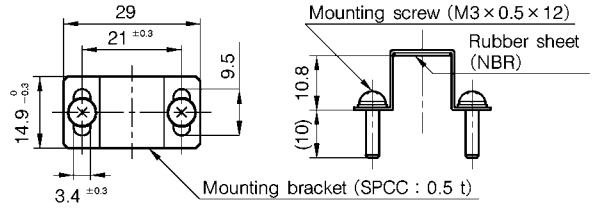

FL2-PA12

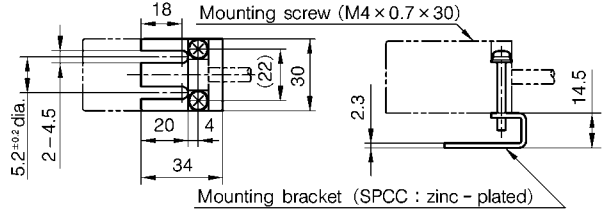

MOUNTING BRACKET (sold separately)

Mounting brackets are made of iron.
Two screws and two washers are provided for each bracket.

Catalog listing	Applicable models
FL2-PA5	FL2S-4□6□
FL2-PA12	FL2R-12□6□

Note: FL2-PA5 is provided with the proximity sensor.

WIRING

- Standard (pre-leaded) model
- Wiring to programmable controller

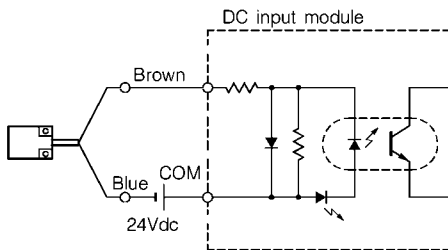

- Wiring to relay load

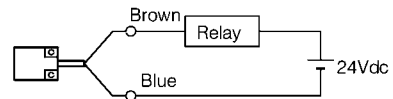

- Wiring to transistor circuit

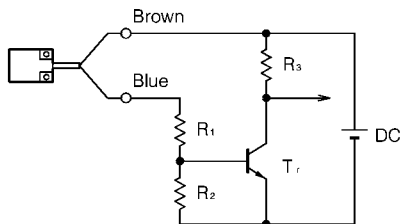

- Wiring to C-MOS circuit

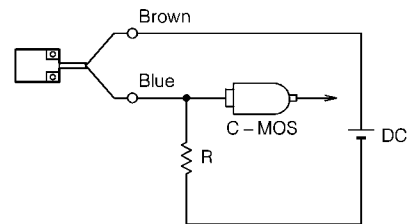

- Pre-leaded connector model

The connectors have four pins. Contacts are laid out as follows.
(Lead colors are for when the PA5 is used.)

Body side

PA5 connector side

N.O. (normally open) type

N.C. (normally closed) type

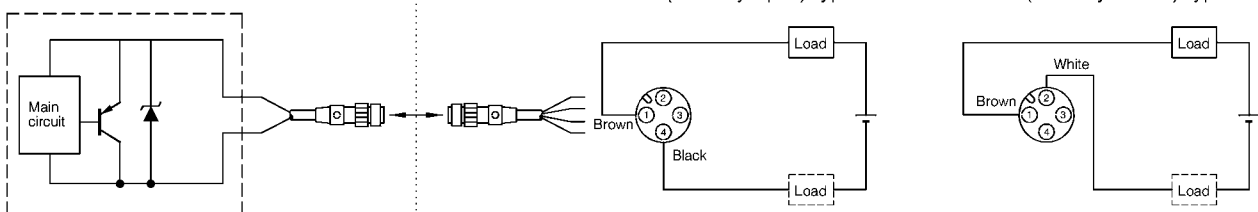

CONNECTOR SPECIFICATIONS Note 1

Item	Specifications
Insulation resistance	100M Ω min. (at 500Vdc)
Dielectric strength	1,500Vac for 1 minute (across contacts, and contacts and connector housing)
Initial contact resistance	40m Ω max. (excluding code conductor-intrinsic when energized by 3A on a male-female contact combination)
Connector withstand stress	0.4 to 4.0N (per contact)
Number of connector insertions	50 times
Connector tightening strength	0.8N-m min. (Note. 2)
Cord pullout strength	100N min.
Vibration resistance	10 to 55Hz, 1.5mm peak-to-peak amplitude, 2 hrs in X, Y and Z directions
Shock resistance	300m/s ² , 3 times in X, Y and Z directions
Protection	IP67
Operating temperature range	- 10 to + 70°C
Storage temperature range	- 20 to + 80°C
Operating humidity range	95%RH max.
Material	Contact: gold-plated brass Contact holder: glass-lined polyester resin Housing: polyester elastomer Coupling: Ni-plated brass O-ring: NBR

Note 1: Specifications assume Yamatake male/female connectors.

Note 2: The recommended torque is 0.4 to 0.6N-m.
If fastened poorly, the IP67 protection is lost, or looseness occurs.
Fasten the connector securely by hand.

CONNECTION CORD WITH CONNECTOR

Be sure to use **PA5** Series cord with **VA** connector when connecting a pre-leaded connector or connector sensors.

● PA5 Series cord with VA connector

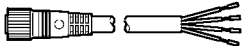
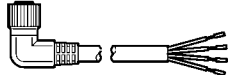
Shape	Power supply	Cord length	Catalog listing	Lead color
	dc	2m	PA5-4ISX2HK	1-brown, 2-white, 3-blue, 4-black
		5m	PA5-4ISX5HK	
		2m	PA5-4ILX2HK	
		5m	PA5-4ILX5HK	

PA5 Series cord with VA connector

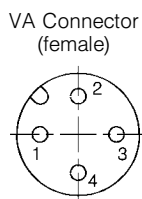
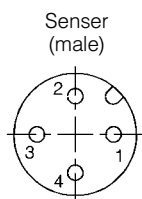
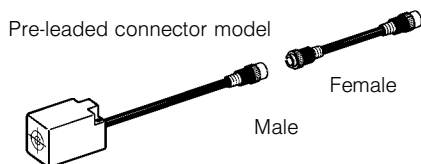

● Fastening the connector

Align the grooves of the connectors and turn the fastening screw of the **VA** connector of the **PA5** cord by hand until it fits tightly with the screw on the sensor side.

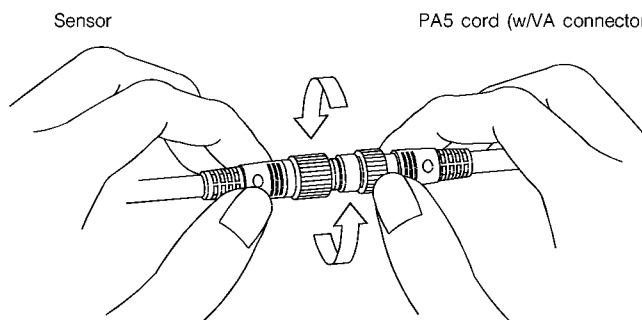

PRECAUTIONS

● Mounting

Tighten the screws to the torque shown below.

Catalog listing	Allowable tightening torque (N-m)	Recommended screw diameter
FL2S- 4□6□	0.5	Screw provided
FL2R- 4□6□	0.5	M3
FL2R- 7□6□	0.5	M4
FL2R-12□6□	0.5	M4
FL2R-20□6□	0.5	M5

● Influence of surrounding metal

Metal other than the object surrounding the sensor may influence operating characteristics. Maintain the following space between the switch and surrounding metal.

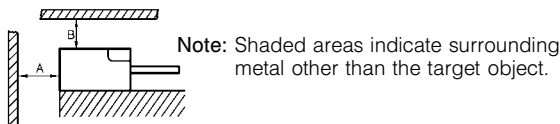

Catalog listing	A (mm)	B (mm)
FL2S- 4□6H	20	10
FL2S- 4□6S	10	20
FL2R- 4□6H	20	10
FL2R- 4□6S	10	20
FL2R- 7□6H	30	15
FL2R- 7□6S	15	30
FL2R-12□6H	50	25
FL2R-12□6S	25	50
FL2R-20□6H	80	40
FL2R-20□6S	40	80

● Mutual interference prevention

When mounting proximity sensors in parallel or facing each other, mutual interference may cause the sensor to malfunction. Maintain at least the spaces indicated in the figures above.

When standard frequency types and different-frequency types “-F” are used alternately in a row, maintain at least the spaces indicated in parentheses “()” for dimensions A and B in the table below.

Side sensing type

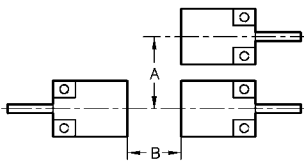

Front sensing type

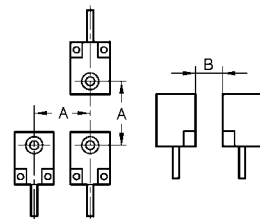

Catalog listing	A (mm)	B (mm)
FL2S- 4□6□	30(15)	40(20)
FL2R- 4□6□	30(15)	40(20)
FL2R- 7□6□	80(40)	80(40)
FL2R-12□6□	120(60)	120(60)
FL2R-20□6□	200(100)	200(100)

● Cautions during series or parallel connection

(1) Series connection (AND connection)

- When connecting two or more proximity sensors in series, erroneous output (1 to 3ms) may occur without the rated current being supplied to each of the sensors. For this reason, series connection of proximity sensors is not recommended. However, if proximity sensors must be connected in series, a resistor of 10kΩ must be provided in parallel to each of the sensors. However, note that the maximum leakage current in a series connection will be 3.5mA.

Operation lag also will occur, resulting in increased voltage drop, and the operation indicator lamp will not light.

$$\text{Operation lag} = 40\text{ms} \times (\text{number of series connections} - 1)$$

$$\text{Voltage drop} = \text{voltage drop of single sensor} \times \text{number of series connected sensors}$$

(2) Parallel connection (OR connection)

- When connecting two or more proximity sensors in parallel, leakage current increases as follows, and may result in faulty load restore.
(Leakage current = Leakage current of single sensor × number of series connected sensors)
- When two or more sensors turn ON in a parallel connection, one (or some) of the sensors may not indicate operation. This is not an abnormality.

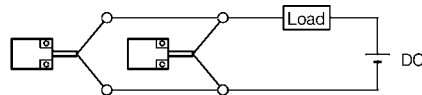

● Relay loads

The voltage drop of the **FL2R/S** Series is 3.3V. Pay attention to this voltage drop when using a relay load. (With 12Vdc relays, switching is not possible.)

● Operation at power ON

After the power is turned ON, it takes 40ms or less until the proximity sensor is ready for sensing.

When the load and the proximity sensor use different power supplies, be sure to turn the proximity sensor ON before turning the load ON.

● Influence of leakage current

Minimal current flows as leakage current for operating the circuits even when the proximity sensor is OFF.

Take sufficient care when restoring connected loads.

● Minimum cord bending radius (R)

The minimum bending radius (R) of the cord is 3 times cord diameter, take care not to excessively bend the cord beyond this radius. Also, do not excessively bend the cord within 30mm of the cord lead-in port.



RESTRICIONS ON USE

This product has been designed, developed and manufactured for general-purpose application in machinery and equipment. Accordingly, when used in applications outlined below, special care should be taken to implement a fail-safe and/or redundant design concept as well as a periodic maintenance program.

- Safety devices for plant worker protection
- Start/stop control devices for transportation and material handling machines
- Aeronautical/aerospace machines
- Control devices for nuclear reactors

Never use this product in applications where human safety may be put at risk.

YAMATAKE

Specifications are subject to change without notice.

Yamatake Corporation
Advanced Automation Company

International Business Headquarters

Totate International Building

2-12-19 Shibuya Shibuya-ku

Tokyo 150-8316 Japan

URL:<http://www.yamatake.com>

This has been printed on 100% recycled paper.

(01)

Printed in Japan (SP)

1st Edition: Issued in Apr., 2002

2nd Edition: Issued in Oct., 2003