

FE8B Series High Seal Diecast Photoelectric Sensors

FEATURES

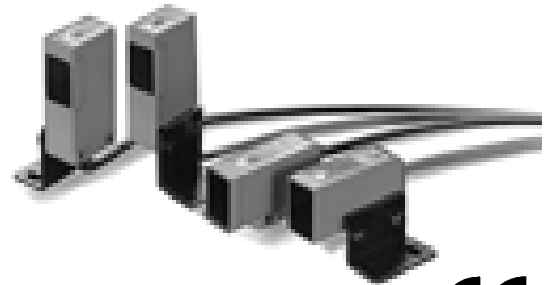

Rugged Housing, IP67 Sealing, Self-diagnostic Output and External Diagnostic Function Are Also Available.

- Compact: 16×21×45mm
- Rugged zinc diecast ultraminiature housing.
- Epoxy potted IP67 sealing.
- Light quantity drop or optical-axis shifting can be prevented in advance by use of self-diagnostic indication and output function. (Thru scan)
- Photoelectric sensor can be checked at start-up of line by use of external diagnostic function. (Thru scan)
- Lens is protected by glass.



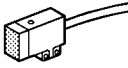

ORDER GUIDE

- Standard type (cord 2m)

Shape	Detection method	Scanning distance	Power supply	Output mode	Operating mode							Catalog listing
					Light operated	Dark operated	Selectable	Sensitivity adjustment	Self-diagnostic indication	Self-diagnostic output	External diagnostic	
Horizontal 	Thru scan	5m	10 to 28Vdc	NPN Open collector	-	-	○	-	○	-	-	FE8B-TC6
		7m			-	-	○	○	-	-	FE8B-TC6G	
	Retroreflective	0.1 to 2m			-	○	-	○	○	-	-	FE8B-TA6P
		0.3m			-	-	○	-	○	-	-	FE8B-TMC6
	Diffuse scan	0.5m			-	-	○	-	○	-	-	FE8B-RC6
		0.5m			-	-	○	○	○	-	-	FE8B-DC6
Vertical 	Thru scan	5m			-	-	○	-	○	-	-	FE8B-TC6V
		7m			-	-	○	○	-	-	FE8B-TC6VG	
	Retroreflective	0.1 to 2m			-	○	-	○	○	-	-	FE8B-TA6VP
		0.3m			-	-	○	-	○	-	-	FE8B-TMC6V
	Diffuse scan	0.5m			-	-	○	-	○	-	-	FE8B-RC6V
		0.5m			-	-	○	○	○	-	-	FE8B-DC6V
				-	-	○	○	-	-	FE8B-DLC6V		

ATTACHMENT (sold separately)

Name	Shape	Contents	Catalog listing	Application model
Small reflector for polarized retroreflective model		A small reflector used when the mounting space of the reflector is not sufficient. To be ordered separately from FE8B .	FE-RR15	FE8B Polarized retroreflective model
Reflector for polarized retroreflective model		To be ordered separately from FE8B .	FE-RR8	

SPECIFICATIONS

Detection method	Thru scan		Retroreflective	Diffuse scan	
Catalog listing	FE8B-TC6(G) FE8B-TC6V(G) FE8B-TA6P FE8B-TA6VP	FE8B-TMC6 FE8B-TMC6V	FE8B-RC6 FE8B-RC6V	FE8B-DC6 FE8B-DC6V	FE8B-DLC6 FE8B-DLC6V
Supply voltage	10 to 28Vdc				
Current consumption	Max 30mA (35mA for products with the self-diagnostic function)				
Scanning distance	5m	7m	0.1 to 2m (reflector: FE-RR8)	0.3m	0.5m
Object	9dia. min. (opaque materials)		50×50mm min. (opaque materials)	Transparent and opaque materials	
Standard target object	—			White paper 20×20cm	
Operation angle	Both emitter and receiver: 3 to 20°		Body: 2 to 10°	—	
Differential	—			20% max. of scanning distance	
Output mode	NPN transistor (open collector)				
Control output	Output switching current: Max. 100mA (resistive load), output dielectric strength: Max. 30V, residual voltage: Max. 1V (at 100mA switching current)				
Self-diagnostic output	Operation mode: Output transistor ON at: incoming of unstable light. Output mode: NPN transistor/open collector. Output switching current: Max. 50mA (resistive load), residual voltage: Max. 1V (at 50mA switching current)				
External diagnostic function	When an input control terminal is connected to the plus terminal of power supply, the light emitter stops the light emitting.				
Response time	ON/OFF time 5ms max.	ON/OFF time 30ms max.	ON/OFF time 5ms max.		
Light emitter	Infrared LED				
Output indicator (self-diagnostic indication)	Light operated (stable light input: green, unstable light input: red), OFF when light is blocked., Power indicator of thru scan emitter: red				
Ambient light resistance	Incandescent lamp: 3,000lux max., Sun light: 10,000lx max.				
Temperature range	-20 to +60°C				
Storage temperature	-40 to +70°C				
Humidity range	35 to 85% RH (non-condensing)				
Insulation resistance	Min. 20MΩ (with 500Vdc megger)				
Dielectric strength	500Vac for one minute				
Vibration resistance	1.5mm double amplitude, 10 to 55Hz in each of X, Y and Z directions for 2 hours				
Shock resistance	490m/s ² in each of X, Y and Z direction 10 times				
Protection	IP67 (IEC Standard)				
Wiring method	Pre-leaded				
Cord	4.2mm dia., 0.2mm ² (11/0.16) section area, 2m long sheath color/No. of cores: Gray/3 leads (thru scan model: Black/2-cores)				
Material	Case: Zinc diecast, Lens: PMMA resin (protected by glass)				
Weight	Approx. 105g (both emitter and receiver for thru scan type), body only with cable				
Others	Reverse power connection protection, False operation protectin at power supply (approx. 70ms), Output short protection				

- Installation Instructions No.: CP-UM-3045E

SELF-DIAGNOSTIC INDICATION

Indication is red when the receiving light quantity is in unstable incoming light area.

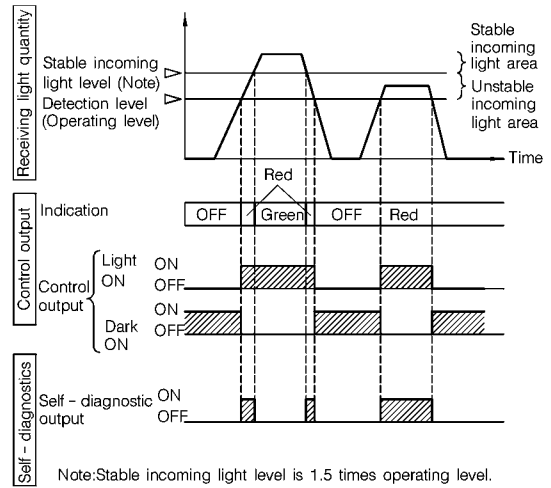

CHARACTERISTICS

- Relative light receiving level
- Thru scan

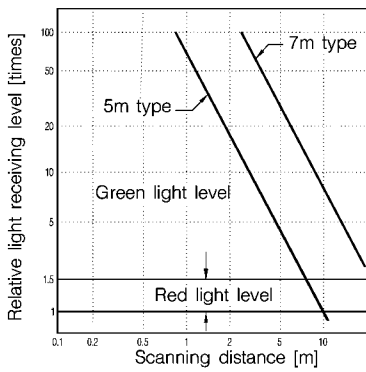

- Retroreflective

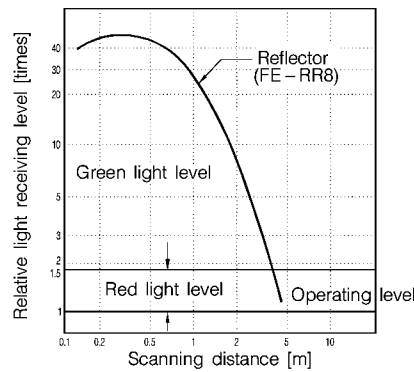

- Diffuse scan

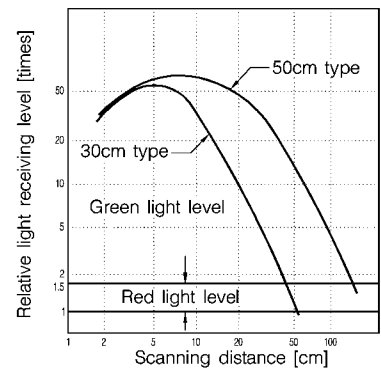

- Parallel motion distance
- Thru scan model

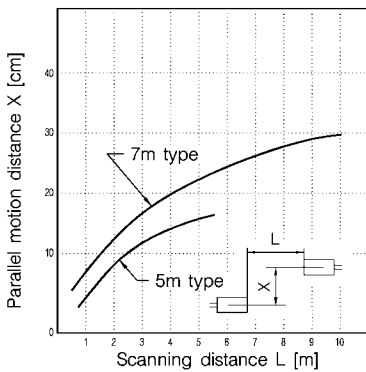

- Retroreflective

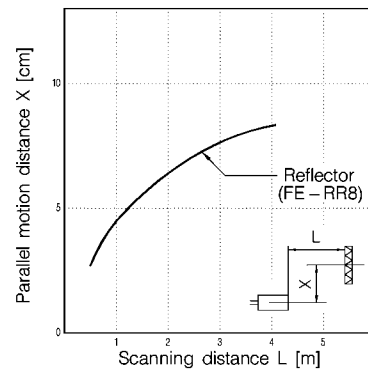

- Detection area
- Diffuse scan

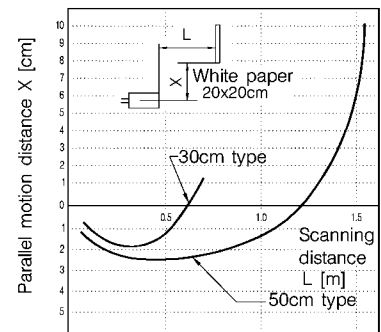

- Scanning distance vs target object size
- Diffuse scan

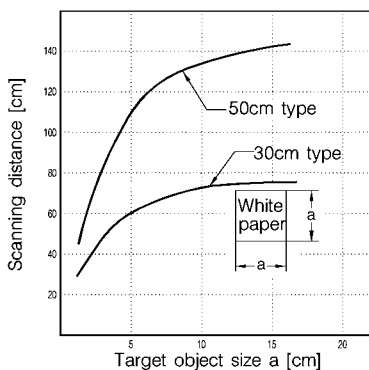

EXTERNAL DIMENSIONS

● Horizontal model

(unit: mm)

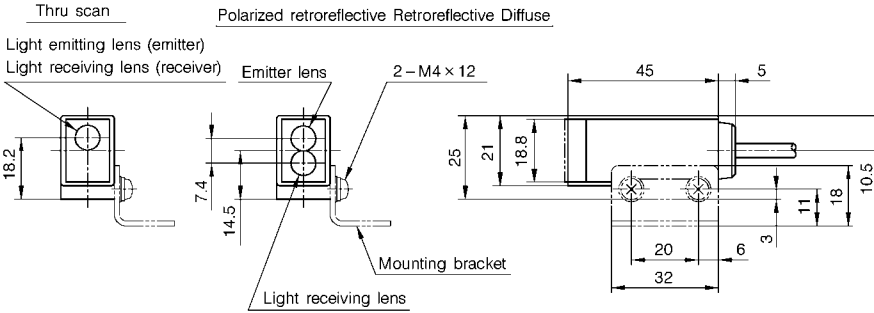
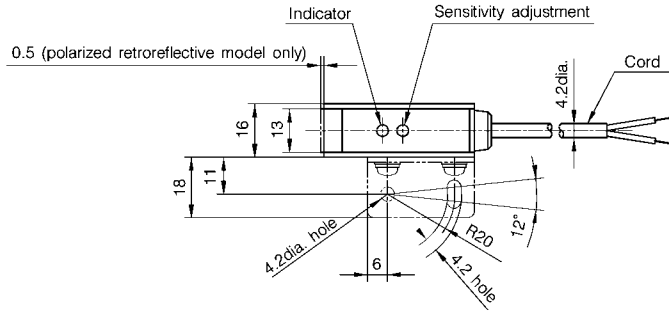

Notes: Mounting bracket, screws and screwdriver are provided.

Lens effective diameter: 9dia.

Products which have sensitivity adjustment feature have a sensitivity level adjustment pot. A screwdriver is provided for adjusting the pot.

● Vertical model

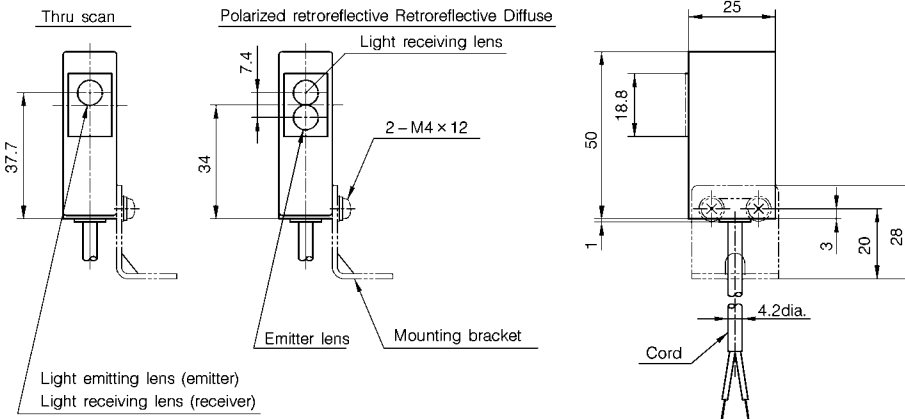
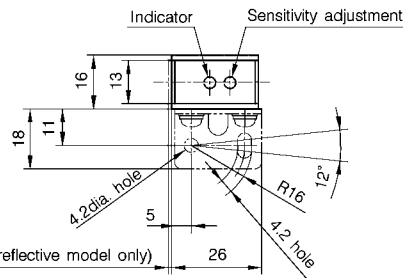

Notes: Mounting bracket, screws and screwdriver are provided.

Lens effective diameter: 9dia.

Products which have sensitivity adjustment feature have a sensitivity level adjustment pot. A screwdriver is provided for adjusting the pot.

● Reflector (option)

● FE-RR8

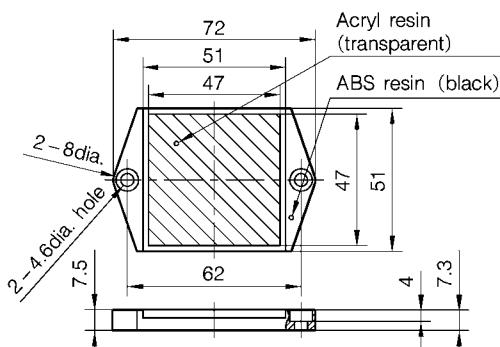

● FE-RR15

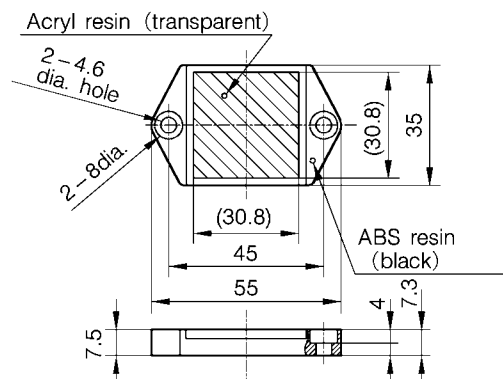

- Mounting bracket for horizontal model (attachment)
- FE-PA8B1

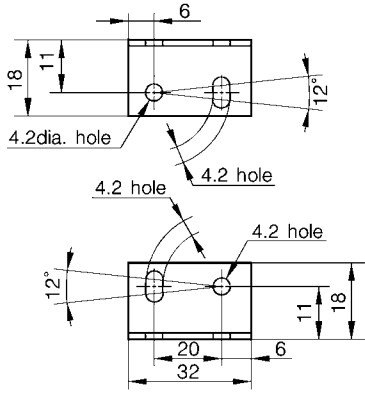

- Mounting bracket for vertical model (attachment)
- FE-PA8B2 (unit: mm)

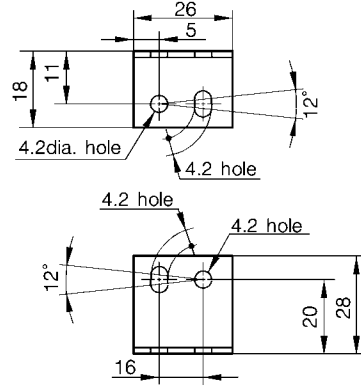

OUTPUT CIRCUIT DIAGRAM

- Thru scan receiver, polarized retroreflective and diffuse scan models

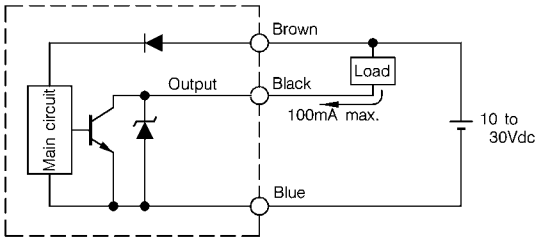

- Thru scan emitter

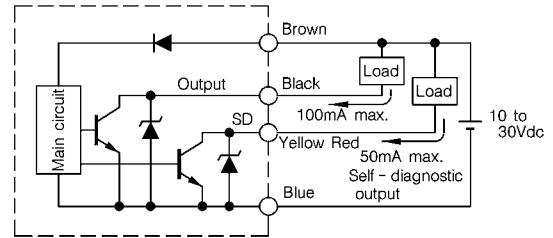

- Thru scan emitter with self-diagnostic output

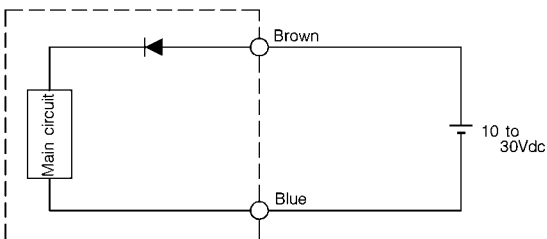

- Thru scan emitter with external diagnostic input

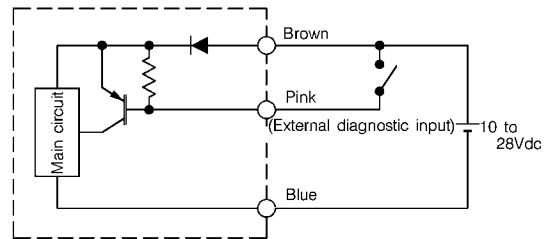

BASIC INSTRUCTIONS

● Optical axis adjustment for thru scan models polarized retroreflective models

Align the emitter and receiver (the main unit and the reflector for retroreflective models).

● Sensitivity adjustment for diffuse scan models

The scanning distance of diffuse scan models depends on the size, material, and reflectance of the target object. Adjust its sensitivity using the following procedure:

(1) When no target object is present, gradually lower the sensitivity from the maximum. The position where the operating indicator LED goes out is "A". If the lamp does not illuminate even when the sensor is set to the maximum, the maximum position will be "A".

(2) Introduce a target object and gradually raise the sensitivity from the minimum. The position where the operating indicator lamp illuminates is "B".

(3) Set the sensitivity equidistant "C", "A" and "B".

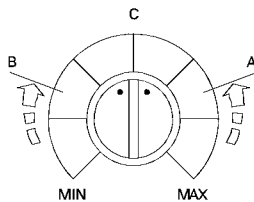

Note: Do not increase the sensitivity too far. If it is turned beyond the scale range, adjustment will become impossible.

● Handling

- Do not swing a photoelectric sensor by its cable.
- Do not pull the lead with too much force. The maximum tensile strength is 49N.
- Do not impact or damage the lens or body.
- Do not expose to water or oil. Do not use outdoors or in an environment where chemicals are used (e.g. organic solvents, acid, alkali).
- Tighten the connectors firmly by hand.
- The bending radius (R) of the cord should be at least 30mm.

● Wiring instructions

- Do not lay photoelectric sensor leads in the same conduit tube with a high voltage or power cable. Surge and electrical noise can cause destruction or incorrect operation.
- Use a lead of at least 0.3mm². The lead length should not be over 100m.
- If a generic switching regulator is used, ground its frame. Otherwise, switching noise may cause incorrect operation.
- If a load generates a rush current (like a capacitive load or a lamp load), insert a current limiting resistor between the load and the output. The output short-circuit protection circuit may be actuated.



RESTRICIONES ON USE

This product has been designed, developed and manufactured for general-purpose application in machinery and equipment. Accordingly, when used in applications outlined below, special care should be taken to implement a fail-safe and/or redundant design concept as well as a periodic maintenance program.

- Safety devices for plant worker protection
- Start/stop control devices for transportation and material handling machines
- Aeronautical/aerospace machines
- Control devices for nuclear reactors

Never use this product in applications where human safety may be put at risk.

YAMATAKE

Specifications are subject to change without notice.

Yamatake Corporation
Advanced Automation Company

International Business Headquarters

Totate International Building

2-12-19 Shibuya Shibuya-ku

Tokyo 150-8316 Japan

URL:<http://www.yamatake.com>

This has been printed on 100% recycled paper.

(01)

Printed in Japan (SP)

1st Edition: Issued in Apr., 2002

2nd Edition: Issued in Oct., 2003