

# SL1 Series

Mechanical life of 20 million operations.  
Robust long-life and maintenance-free compact horizontal-type limit switches with IP67 seal.



- Mechanical life exceeds 20 million operations, owing to a 2-piece spring mechanism
- High sensitivity (M.D. = 0.1mm)
- Superior seal: oil-resistant/immersion-proof type (JIS) and IP67 (IEC). O-ring and integral diaphragm seal are built in
- Small, space-saving body can be tightly gang-mounted
- UL/CSA/CE/CCC-certified models are available



CLICK

## PERFORMANCE

	Item	Details
Standards	Compliance	JIS C 8201-5-1/IEC 60947-5-1
	Certification	UL 508/CSA C22.2 No. 14/EN 60947-5-1/GB14048.5-2001 (except high oil- and heat-resistance types)
Structure	Contact form	Single-Pole Double-Throw (SPDT; refer to contact diagram below)
	Contact type	Standard load type: pure silver rivet Low current load type: gold-plated rivet
	Terminal type	M3 screw
	Protective structure	IP67 (IEC 60529, JIS C 0920)
	Pollution level	3
Electrical performance	Electrical rating	See Table 1.
	Rated frequency	45 to 65Hz and D.C.
	Insulation resistance	Between non-continuous terminals: 100MΩ Between each terminal and non-live metal parts: 100MΩ
	Rated insulation resistance (Ui)	250V Dielectric strength between each terminal and non-conducting metal parts: 2,000Vac (50 to 60Hz, 5s, leak current 1mA)
	Dielectric strength between contacts	1,000Vac (50 to 60Hz, 5s, leak current 1mA)
	Rated impulse dielectric strength (Uimp)	2,500V
	Switching overcurrent	Category II (60204-1)
	Initial contact resistance	Silver contacts: 50mΩ max. (6 to 8Vdc 1A, voltage drop method) Gold-plated contacts: 100mΩ max. (6 to 8Vdc 0.1A, voltage drop method)
	Contact minimum allowable load	Silver contacts: 5mA 24Vdc, 10mA 12Vdc Gold-plated contacts: 5mA 5Vdc
	Rated thermal current (Ith)	Silver contacts: 5A Gold-plated contacts: 1A (Temperature increase: 65°C max.)
	Short-circuit protection	M10A(IEC 60127) (TÜV) Instant blowing fuse, 10A (silver contacts) or 3A (gold contacts) (CQC)
Conditional rated short-circuit current	1,000A (power factor 0.5 to 0.7)	
Mechanical performance	Actuator strength	Withstands load 5 times O.F. (operating direction for 1 minute)
	Terminal strength	Withstands tightening torque of 0.6N·m for 1 minute
	Impact resistance (malfunction)	300m/s <sup>2</sup> , contact opening for 1ms max. in free position and total travel position
	Vibration resistance (malfunction)	1.5mm peak-to-peak amplitude for 2 continuous hours Contact opening for 1ms max. in free position and total travel position
	Allowable operating speed	0.02mm/s to 0.5m/s. 0.02mm/s to 0.25m/s on the SL1-B Series
	Operating frequency	120 operations/minute. (60 operations/min for cold- and weather-resistant / high oil and heat resistance type).

Life	Mechanical	Min. 20 million operations. Min. 2 million operations for the SL1-B Series. Min. 1 million operations for cold- and weather-resistant type. Min. 2 million operations for high oil and heat resistance type. (All values assume overtravel (O.T.) of 1/3 to 2/3 the rated amount.)
	Electrical	Standard load type: Min. 2 million operations (125Vac 1A) Min. 300,000 operations (250Vac 5A, 48Vdc 2A, 30Vdc 5A) Low current load type: Min. 5 million operations (125Vac-0.1A, 48Vdc-0.1A)
Ambient operating conditions	Temperature	Standard type: -10 to +70°C Cold and weather resistant type: -40 to +70°C -30 to +70°C for SL1-B High oil and heat resistance type: 0 to 120°C
	Humidity	Max. 98% RH
Recommended tightening torque	Body	1.3 to 1.7N·m (M4 hexagon socket head bolt)
	Terminal screw	0.4 to 0.6N·m (M3 binding head machine screw)
	Panel mounting nut	4 to 6N·m (M14 hexagonal nut)

●Table 1. Electrical rating

Item	Contact material	JIS/IEC/EN	UL/CSA
Standard load type	Silver	AC-15:3A-250V AC-12:5A-250V DC-12:2A-48V	5A-250V ac General Use Load 5A-30V dc
Low current load type	Gold-plated	AC-12:0.1A-125V DC-12:0.1A-48V	0.1A-125V ac General Use Load 0.1A-30V dc

●Reference ratings (Since values can vary due to operating environment and type of load, verify them on an operating unit.)

Standard load model with silver contacts

AC rating	125Vac				250Vac			
	Resistance	Induction	Electric motor		Resistance	Induction	Electric motor	
			N.C.	N.O.			N.C.	N.O.
Current (A)	5	3	1	2	5	3	0.5	1

Low current load type with gold-plated contacts

AC rating	115Vac	
	Resistance	Induction
Current (A)	0.1	—

DC rating	8Vdc		14Vdc		30Vdc		115Vdc		230Vdc	
	Resistance	Induction	Resistance	Induction	Resistance	Induction	Resistance	Induction	Resistance	Induction
Current (A)	5	3	5	3	5	3	0.5	0.1	0.25	0.05

DC rating	8Vdc	14Vdc	30Vdc	
	Resistance	Induction	Resistance	Induction
Current (A)	0.1	—	0.1	—

Note: "Induction" refers to a load having a power factor of 0.4 and time constant of 7ms (DC). "Electric motor" refers to a load having a value of six times the inrush current.

CONTACT FORM

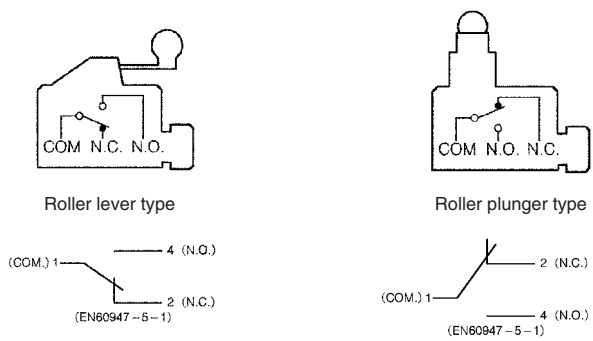







STANDARDS

	Approving body	Standard	File No.
Certification	UL	UL 508 CSA C22.2 No.14	E 96090
	TÜV	EN 60947-5-1	R2-50006349
	CQC	GB 14048.5-2001	2003010305083850

## ORDER GUIDE







### ● Without cable

Actuator		Basic catalog listing*2	Options			
Name	Shape		Low current load K *2	Cold- and weather-resistant L *2	Cold- and weather-resistant + low current load KL *2	High temperature and high oil resistance V
Roller plunger		SL1-A	SL1-AK	SL1-AL	SL1-AKL	SL1-AV
Boot seal roller plunger		SL1-B	SL1-BK	SL1-BL	—	SL1-BV
Cross roller plunger		SL1-D	SL1-DK	SL1-DL	SL1-DKL	SL1-DV
Long roller plunger		SL1-E	SL1-EK	SL1-EL	—	SL1-EV
Plunger		SL1-H	SL1-HK	SL1-HL	SL1-HKL	SL1-HV
Short roller lever		SL1-P	SL1-PK	SL1-PL	SL1-PKL	SL1-PV

\*1: Use with SL1-PA12.

\*2: UL/C-UL/CE/CCC-certified model.

### ● With cable

Actuator		Options			
Name	Shape	No resin filling A:Cable exits on right B:Cable exits on left	With resin filling X:Cable exits on right Y:Cable exits on left	No resin filling+low current load A:Cable exits on right B:Cable exits on left	Resin filling+low current load X:Cable exits on right Y:Cable exits on left
		Roller plunger		SL1-A□G*	SL1-A□G*
Boot seal roller plunger		SL1-B□G*	SL1-B□G*	SL1-BK□G*	SL1-BK□G*
Cross roller plunger		SL1-D□G*	SL1-D□G*	SL1-DK□G*	SL1-DK□G*
Long roller plunger		SL1-E□G*	SL1-E□G*	SL1-EK□G*	SL1-EK□G*
Plunger		SL1-H□G*	SL1-H□G*	SL1-HK□G*	SL1-HK□G*
Short roller lever		SL1-P□G*	SL1-P□G*	SL1-PK□G*	SL1-PK□G*



\*Asterisk ( \* ) after G indicates selectable cable length (1/2/3/5m).

\*Model with indicator is available for SL1 switches with cable, except for those without resin filling.

Options		
High temperature and high oil resistance + low current load KV	Without cover N *1,2	Without cover + low current load KN *1,2
SL1-AKV	SL1-AN	SL1-AKN
—	—	SL1-BKN
—	SL1-DN	SL1-DKN
—	SL1-EN	—
—	SL1-HN	SL1-HKN
SL1-PKV	SL1-PN	—

Options			
Resin filling+AC indicator X:Cable exits on right Y:Cable exits on left	Resin filling+DC indicator X:Cable exits on right Y:Cable exits on left	Resin filling+low current load +AC indicator X:Cable exits on right Y:Cable exits on left	Resin filling+low current load +DC indicator X:Cable exits on right Y:Cable exits on left
SL1-AE□G*	SL1-AF□G*	SL1-AKE□G*	SL1-AKF□G*
SL1-BE□G*	SL1-BF□G*	SL1-BKE□G*	SL1-BKF□G*
SL1-DE□G*	SL1-DF□G*	SL1-DKE□G*	SL1-DKF□G*
SL1-EE□G*	SL1-EF□G*	SL1-EKE□G*	SL1-EKF□G*
SL1-HE□G*	SL1-HF□G*	SL1-HKE□G*	SL1-HKF□G*
SL1-PE□G*	SL1-PF□G*	SL1-PKE□G*	SL1-PKF□G*

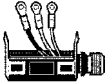
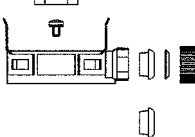
## AUXILIARY PARTS

Name	Appearance	Specifications	Catalog listing
PA5 Series connector cover		For DC type, 3 leads	SL1-PA5I3
Terminal cover set		Cover, panel mounting nuts (2), cap nut, washer and seals (for 5.8 to 7.8mm dia. cable and for 7.9 to 9.6mm dia. cable)	SL1-PA12
Seal		for 7.9 to 9.6mm dia. cable (set of 10): Standard type: NBR containing PVC.	SL1-PA22
		for 7.9 to 9.6mm dia. cable (set of 10): Cold- and weather-resistant type: fluorosilicone rubber.	SL1-PA23
		for 7.9 to 9.6mm dia. cable (set of 10): High temperature and high oil resistance type: fluorocarbon rubber.	SL1-PA24

### Connector for SL1 Series

Switches in the SL1 Series can be modified into the connector type by attaching the SL1-PA5I3 onto the SL1 switch body, as shown below. Either replace the terminal cover of the SL1 standard type switch with a sealed connector with cable, or use the switch without a terminal cover.

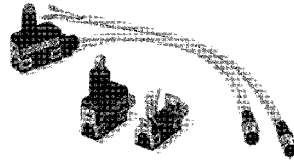

### Assembly method

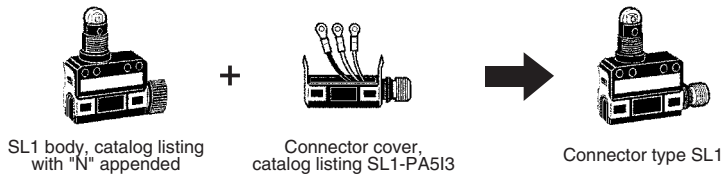

### Wiring diagrams

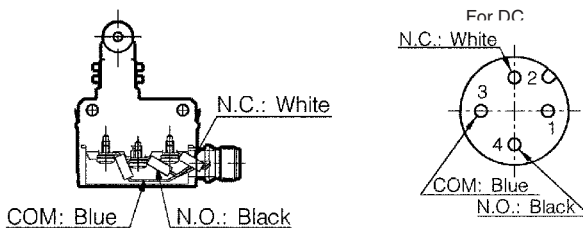

### External dimensions

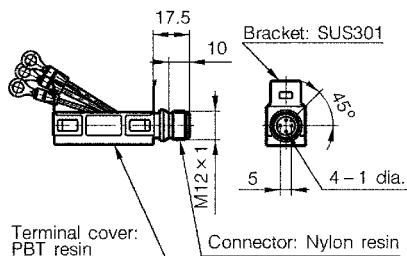

## Electrical life

### ● Normal load type

#### Contacts used for AC

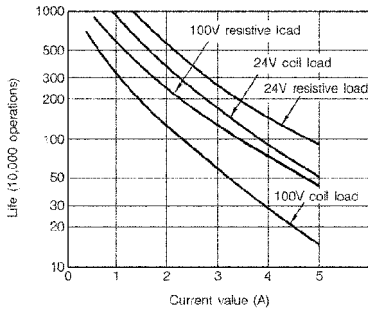

#### Contacts used for DC

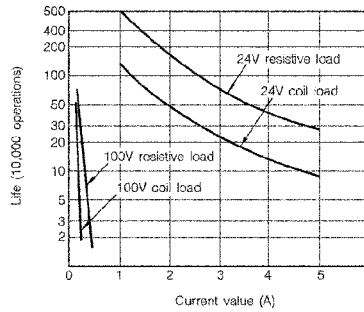

### ● Low current load type

#### Contacts used for AC

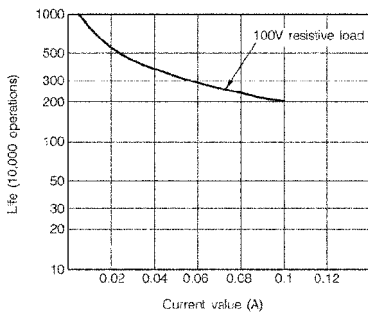

#### Contacts used for DC

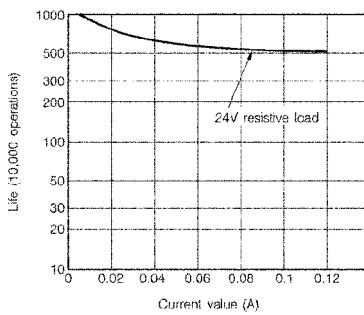

## STRUCTURAL DIAGRAM

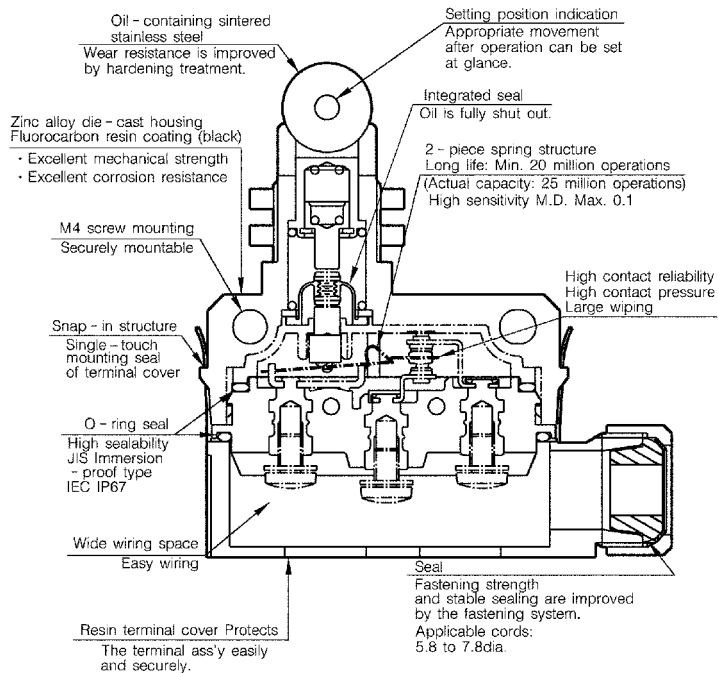

**Roller plunger type**



Catalog listing	SL1-A□□
Operating force O.F. (max. N)	11.8
Release force R.F. (min. N)	4.9
Pretravel P.T. (max. mm)	1.5
Overtravel O.T. (min. mm)	3
Movement differential M.D. (max. mm)	0.1
Operating position O.P.(mm)	31.4±0.8

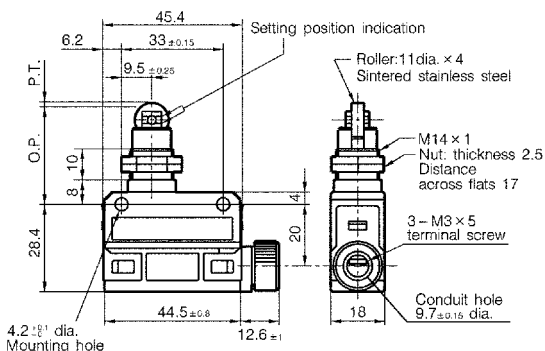

**Boot seal roller plunger type**



Catalog listing	SL1-B□□
Operating force O.F. (max. N)	11.8
Release force R.F. (min. N)	4.9
Pretravel P.T. (max. mm)	1.5
Overtravel O.T. (min. mm)	3
Movement differential M.D. (max. mm)	0.1
Operating position O.P.(mm)	41.4±0.8

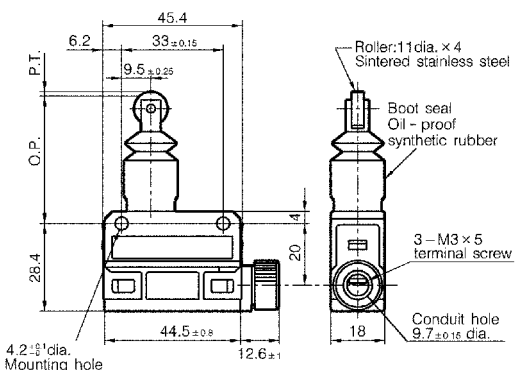

**Cross roller plunger type**



Catalog listing	SL1-D□□
Operating force O.F. (max. N)	11.8
Release force R.F. (min. N)	4.9
Pretravel P.T. (max. mm)	1.5
Overtravel O.T. (min. mm)	3
Movement differential M.D. (max. mm)	0.1
Operating position O.P.(mm)	31.4±0.8

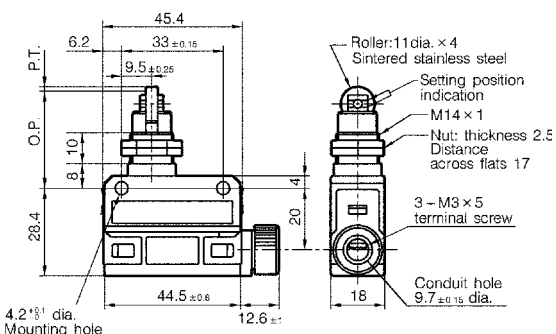

## Long roller plunger type



Catalog listing	SL1-E□□
Operating force O.F. (max. N)	11.8
Release force R.F. (min. N)	4.9
Pretravel P.T. (max. mm)	1.5
Overtravel O.T. (min. mm)	3
Movement differential M.D. (max. mm)	0.1
Operating position O.P.(mm)	41.4 $\pm$ 0.8

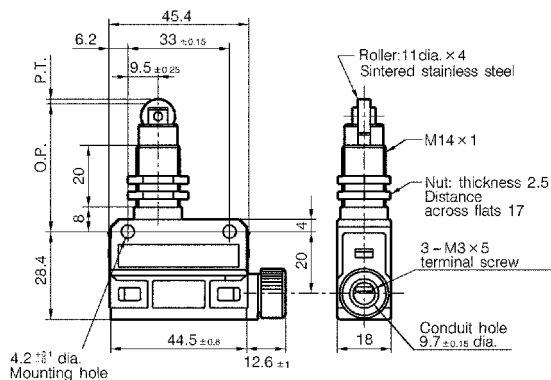

## Plunger type



Catalog listing	SL1-H□□
Operating force O.F. (max. N)	11.8
Release force R.F. (min. N)	4.9
Pretravel P.T. (max. mm)	1.5
Overtravel O.T. (min. mm)	3
Movement differential M.D. (max. mm)	0.1
Operating position O.P.(mm)	25.4 $\pm$ 0.8

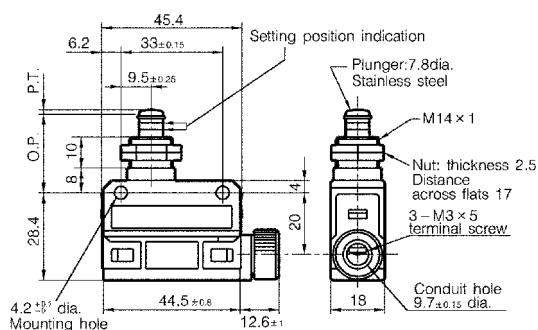

## Short roller lever type



Catalog listing	SL1-P□□
Operating force O.F. (max. N)	4.0
Release force R.F. (min. N)	0.78
Pretravel P.T. (max. mm)	2
Overtravel O.T. (min. mm)	4
Movement differential M.D. (max. mm)	0.3
Operating position O.P.(mm)	23.1 $\pm$ 0.8

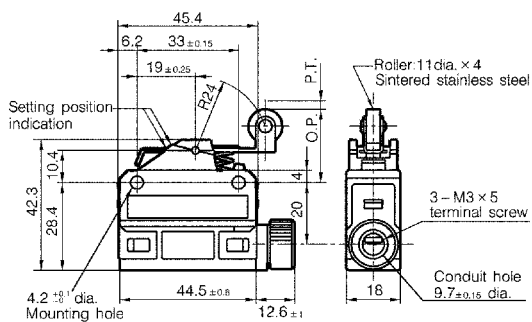

# PRECAUTIONS FOR USE

## 1. Preparing lead wire tips

Cut and strip the lead wire tip as illustrated below, and use a round crimp-type terminal lug having an M3 insulating sleeve. A bare crimp-type terminal lug will cause a short-circuit. If a bare crimp-type terminal lug must be used, insulate it with a sleeve or the like, or point the terminal lugs in opposite directions to prevent a short-circuit.

Lead wire connection direction and recommended cutting sizes (unit: mm)

### 1.1 For 3-core wires

- An example of standard connection using crimp-type terminal lug, having an insulation sleeve

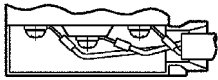

- An example of insulating a bare crimp-type terminal lug with a mark tube or the like



Mark tube or the like

- ✗ A wrong example of using a bare crimp-type terminal lug



Short circuit

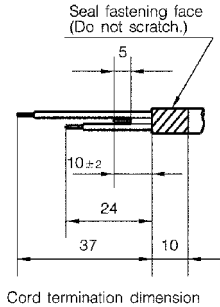

Cord termination dimension

### 1.2 For 2-core wires

(unit: mm)

- An example of reversing the direction of a bare crimp-type terminal lug

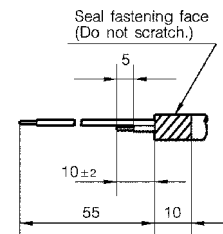
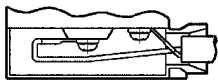

Cord termination dimension

## 2. Wiring

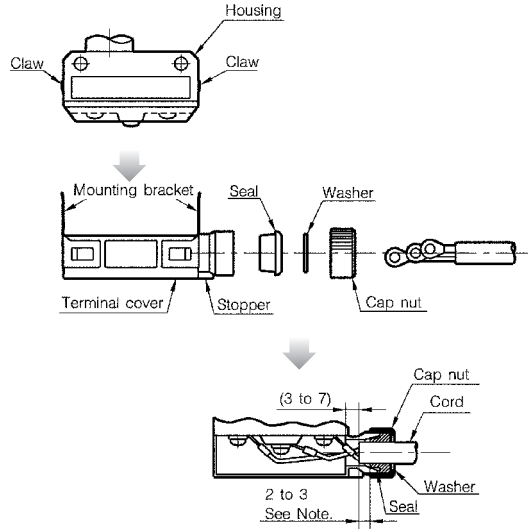

Note: Assemble these components so that the cable sheath protrudes 2 to 3mm from the end of the seal.

- Add components to the cable in the order: cap nut, washer, seal and terminal cover.
- Make sure that the mounting bracket on the terminal cover is held by the catches of the housing in this snap-in structure. Then tighten with the cap nut.
- To remove the terminal cover, release the snap-in structure with a screwdriver by expanding the mounting bracket on one side.
- The cable can be drawn out rightward or leftward by changing the mounting direction of the terminal cover.
- Be careful since the terminal layout differs for the (roller) lever type and (roller) plunger type, as illustrated below.

(roller) lever type

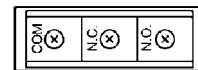

(roller) plunger type

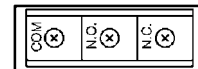

- A seal suitable for a cable diameter of 5.8 to 7.8mm is attached to the terminal cover at the factory. If a cable of a different diameter is used, use replacement seal **SL1-PA22**, **SL1-PA23** or **SL1-PA24** (sold separately). To ensure a good seal, be sure to use a seal matching the diameter of the cable. If a question arises, please contact your nearest Yamatake sales agent.