

LS Series

General purpose limit switches with robust construction in an extensive range of models, for use in a wide range of applications.









- UL/CSA/EN (CE) /GB (CCC) certified
- 2-circuit double break basic switch with rugged die-cast aluminum case
- Oil-, water- and dust-proof structure (IP67 protective structure)
- Wide range of options available: with neon lamp, with LED lamp, built-in gold-plated contacts, with double seal, corrosion-resistant, heat-resistant, cold-resistant, spatter-guarded, connector type, etc
- Operation position setting indicator (roller lever and roller plunger types)



CLICK

LIST OF MODELS

Appearance		Roller lever	Plunger	Side roller plunger	Roller plunger	Fork lever lock	Non-directional operating rod lever	Reference page for individual specifications
Model								
General purpose	<input type="checkbox"/> LS□-J	○	○	○	○	○	○	D-019
Spatter-guarded	<input type="checkbox"/> LS□□-JW□	○	—	—	○	—	—	D-045
Ultra long life	1LS-J7□□	○	—	—	—	—	—	D-052
Weather resistant	1LS-J8□□	○	—	—	—	—	—	D-060
All stainless steel	1LS□-J401	○	—	—	—	—	—	D-064

STANDARD, GENERAL PURPOSE COMPACT TYPE

Most versatile LS compact limit-switch model, used in a wide range of applications.



- Wide range of models includes standard, high sensitivity, high overtravel, T.T. 90°, light operation and lock operation types.
- Wide range of actuator types.
- Certified compliance with a variety of international standards (UL/CSA, EN 60947-5-1, etc.)
- CCC-marked product with ground lead.
- Connector/prelead connector also available.
- With LED lamp (12V to 125Vac/dc). Neon lamp also available.
- Wide range of models includes double-sealed, corrosion-resistant, heat-resistant, and cold-resistant types.
- Low current load model also available.

STANDARDS COMPLIANCE

Certifying Body	Standard	File No.
UL	UL 1054	E 37559
CSA	CSA C22.2 No.55	LR 61643
TÜV	EN 60947-5-1	R 9451261
CQC	GB14048.5-2001	2003010305083775

*To be changed to UL508.

Item	Model	Roller lever	Plunger	Side roller plunger	Roller plunger	Fork lever lock	Non-directional operation type				
	Catalog listing	1LS□-J□□□	2LS□-J□	3LS1-J	5LS□-J	6LS□-J	8LS□-J				
Standards	Compliance	JIS C 4508/JIS C 8201-5-1, IEC 60947-5-1									
	Certification *1	UL/CSA, EN 60947-5-1, GB 14048.5-2001									
Structure	Contact form	2-circuit double break									
	Contact type	Standard load	Silver, rivet								
		Low current load	Gold-plated silver, rivet								
	Terminal type	M4 screw (binding head machine screw with toothed washer), DIN 4-pin connector (M12 size), preloaded									
	Protective structure	IP67 (IEC60529, JIS C 0920)									
Pollution level	3 (EN 60947-5-1)*2										
Electrical performance (1): General characteristics	Electrical rating	See page D-024.									
	Dielectric strength	Between non-continuous terminals	: 1,000Vac, 50/60Hz for 1 minute (standard operating characteristics type)								
		Between each terminal and non-live metal part	: 600Vac, 50/60Hz for 1 minute (roller lever, high sensitivity characteristics type)								
		Between each terminal and ground	: 2,000Vac, 50/60Hz for 1 minute. : 2,000Vac, 50/60Hz for 1 minute (only G-type products with ground terminals).								
	Insulation resistance		Min. 100MΩ (by 500Vdc megger)								
		Initial contact resistance	Standard load	Max. 50mΩ (6 to 8Vdc, thermal current 1A, voltage drop method)							
	Low current load		Max. 100mΩ (6 to 8Vdc, thermal current 0.1A, voltage drop method)								
	Connector	Max. 40mΩ (excluding fixed resistance such as cable)									
	Contact voltage/min.current	24V 10mA, 12V 20mA (standard load), 5V 10mA (low current load)									
	Electrical performance (2) EN60947-5-1 GB140 48.5-2001	Rated operating voltage	240Vac, 30Vdc								
Rated thermal current (Ith)		Silver contacts: 10A. Gold-plated contacts: 1A.									
Rated frequency		45 to 65Hz and DC									
Short-circuit protection		TÜV F10A fuse (IEC 60127) / CQC instant blowing fuses: silver contacts 15A, gold contacts 3A									
Rated insulating voltage (Ui)		250Vac									
Rated conditional short-circuit current		1,000A									
Switching overvoltage		Category III (IEC 60204-1)									
Rated impulse dielectric strength (Uimp)		Between each terminal and ground, and between terminals: 2,500V.									
Mechanical performance	Actuator strength	Withstands load 5 times O.F. for 1 minute (in operating direction)									
	Terminal strength	Withstands tightening torque of 1.5N·m for 1 minute									
	Impact resistance	Model	High sensitivity roller lever type	200m/s ² in free and total travel positions							
			Light operation roller lever & non-directional roller lever types	200m/s ² in total travel position							
			Non-directional operation type	300m/s ² in total travel position							
			Models other than the above	300m/s ² in free and total travel positions							
			Contact opening for 1ms max. in free and total travel positions								
	Vibration resistance	Model	1.5mm peak-to-peak amplitude, frequency 10 to 55Hz, for 2 continuous hours								
			High sensitivity roller lever type & non-directional type	In total travel position							
			Models other than the above	In free and total travel positions							
Contact opening for 1ms max. in free and total travel positions											
Allowable operating speed	Model	Other than on the right	1LS19-J	2LS1-J	2LS-J6	3LS1-J	5LS1-J/5LS7-J	8LS3-J	8LS125-J	8LS152-J	
		Max.	0.5m/s	0.5m/s	0.5m/s	0.2m/s	0.3m/s	0.5m/s	0.5m/s	0.3m/s	0.3m/s
Min.	1.7mm/s	0.4mm/s	1.0mm/s	1.0mm/s	0.5mm/s	0.2mm/s	10mm/s	50mm/s	20mm/s		
Operating frequency	At max. speed, actuator is not damaged. At min. speed, contact instability lasts 0.1s max. Light operation roller lever/ heat-resistant/ cold-resistant: max. 60 operations/minute, Models other than the above: max. 120 operations/minute										
Cable pullout strength	Min. 100N										
Life	Mechanical life	Model	Other than on the right			1LS-J50, 2LS-J6, cold-resistant type		3LS1-J		6LS□J, heat-resistant type	
		Life	Min. 10 million operations			Min. 1 million operations		Min. 5 million operations		Min. 2 million operations	
	(At 1/3 to 2/3 of the rated overtravel.)										
	Electrical life	Model	Standard load built-in switch			Standard load double seal built-in switch			Low current load built-in switch		
Life		Min. 500,000 operations at rated load			Min. 200,000 operations at rated load			Min. 2 million operations at rated load			
Operating frequency: Above conditions must be satisfied at 20 operations/minute.											
Ambient operating conditions	Temperature	Standard model (standard load and low current load) : -10 to +70°C (freezing not allowed)									
		Double seal type : 1LS19-JS: 0 to +70°C (freezing not allowed)									
		: 2LS, 3LS, 5LS, 8LS125-JS: +5 to +70°C (freezing not allowed)									
		Double seal type other than above: -5 to +70°C (freezing not allowed)									
		Heat-resistant type : -10 to +120°C (freezing not allowed)									
Cold-resistant type : -40 to +70°C (freezing not allowed)											
Humidity	Max. 98% RH*3										
Recommended tightening torque	Body	5 to 6N·m (M5 hexagon socket head bolt)									
	Lever	4 to 5.2N·m (M5 hexagon socket head bolt)									
	Terminal	1.0 to 1.4N·m (M4 binding head machine screw)									
	Cover	1.3 to 1.7N·m (M4 small round head screw)									
	Head	0.8 to 1.2N·m (M3.5 small round head screw)									
	Cap nut	2 to 3N·m (M22 screw for 3LS)									
	Piano wire lever	0.6 to 0.8N·m (M3 hexagon head set screw)									
Connector tightening torque	0.4 to 0.6N·m (M12 ring)										

Notes: Mechanical performance values for the roller lever type are for lever length of 38.1mm.





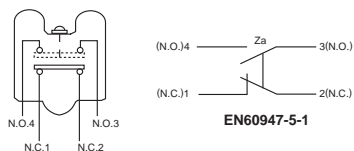





*1. Some models do not fall under this category. *2. EN 60947-5-1 and GB 14048.5-2001 applies only to G-type products with a ground terminal. *3. Max. 95% RH for connector and preloaded connector types

● Contact type 2-circuit double break



ORDER GUIDE

● Switch body (contact your dealer for models not listed in the following table)

Actuator		Operating characteristics			Basic catalog listing	Options			
		Max. O.F. (operating force)	Max. P.T. (pretravel)	Min. T.T. (total travel)		With LED lamp, 12 to 125Vac/dc EC	With neon lamp, 100/200Vac E	Double seal S	
Name	Shape								
Roller lever		13.4N	Standard model 20°	Standard travel50°	1LS1-J	1LS1-JEC	1LS1-JE	1LS1-JS	
			High sensitivity 5°	Standard travel35°	1LS19-J	1LS19-JEC	1LS19-JE	1LS19-JS	
		8.9N	Standard model 20°	High overtravel75°	1LS-J500	1LS-J500EC	1LS-J500E	1LS-J500S	
			High sensitivity 10°	High overtravel75°	1LS-J550	1LS-J550EC	1LS-J550E	1LS-J550S	
			Standard model 30°	High overtravel90°	1LS-J50	1LS-J50EC	1LS-J50E	1LS-J50S	
Adjustable roller lever*1		13.4N	Standard model 20°	Standard travel50°	1LS3-J	1LS3-JEC	1LS3-JE	1LS3-JS	
		8.9N	Standard model 20°	High overtravel75°	1LS-J503	1LS-J503EC	1LS-J503E	1LS-J503S	
			High sensitivity 10°	High overtravel75°	1LS-J553	1LS-J553EC	1LS-J553E	1LS-J553S	
Light operation rod lever*2		1.4N	Standard model 20°	Standard travel50°	1LS10-J	1LS10-JEC	1LS10-JE	1LS10-JS	
Lever-less type		13.4N *1	Standard model 20°	Standard travel50°	1LS2-J	1LS2-JEC	1LS2-JE	1LS2-JS	
			High sensitivity 5°	Standard travel35°	1LS9-J	1LS9-JEC	—	—	
		8.9N *1	Standard model 20°	High overtravel75°	1LS-J501	1LS-J501EC	1LS-J501E	1LS-J501S	
			High sensitivity 10°	High overtravel75°	1LS-J551	1LS-J551EC	1LS-J551E	1LS-J551S	
			Standard model 30°	High overtravel90°	1LS-J51	1LS-J51EC	1LS-J51E	1LS-J51S	
1.4N *2	Standard model 20°	Standard travel50°	1LS23-J	—	1LS23-JE	—			
Plunger		26.7N	1.65mm	8.05mm	2LS1-J	2LS1-JEC	2LS1-JE	2LS1-JS	
Ball plunger		26.7N	1.7mm	5.7mm	2LS-J6	2LS-J6EC	2LS-J6E	—	
Side roller plunger		40.1N	2.77mm	8.37mm	3LS1-J	3LS1-JEC	3LS1-JE	3LS1-JS	
Roller plunger		26.7N	1.7 mm	7.3 mm	5LS1-J	5LS1-JEC	5LS1-JE	5LS1-JS	
Boot seal roller plunger		15.7N	1.7 mm	7.3 mm	5LS7-J	5LS7-JEC	5LS7-JE	5LS7-JS	
Fork lever lock		8.9N	60°	90°	6LS1-J	6LS1-JEC	6LS1-JE	6LS1-JS	
		8.9N	60°	90°	6LS3-J	6LS3-JEC	6LS3-JE	6LS3-JS	
Non-directional operation type		Spring rod	1.4N	28.6mm	—	8LS3-J	8LS3-JEC	8LS3-JE	8LS3-JS
		Steel wire light operation	0.28N	55mm	—	8LS125-J	8LS125-JEC	8LS125-JE	8LS125-JS
		Coil spring	1.4N	28.6mm	—	8LS152-J	8LS152-JEC	8LS152-JE	8LS152-JS

*1. Values are for lever length of 38.1mm.



*2. Values are for lever length of 141.2mm.

 UL/CSA-approved products

 UL/CSA/CE/CCC-approved products

Options								
Double seal + LED SEC	Double seal + neon lamp SE	Low current load K	EN/GB-compliant with GND terminal G	EN/GB-compliant with GND + LED GEC	EN/GB-compliant with GND + LED & dbl seal SGEC	Corrosion-resistant type M	Heat-resistant type H	Cold-resistant type L
1LS1-JSEC	1LS1-JSE	1LS1-JK	1LS1-JG	1LS1-JGEC	1LS1-JSGEC	1LS1-JM	1LS1-JH	1LS1-JL
1LS19-JSEC	1LS19-JSE	1LS19-JK	1LS19-JG	1LS19-JGEC	1LS19-JSGEC	1LS19-JM	1LS19-JH	1LS19-JL
1LS-J500SEC	1LS-J500SE	1LS-J500K	1LS-J500G	1LS-J500GEC	1LS-J500SGEC	1LS-J500M	1LS-J500H	1LS-J500L
1LS-J550SEC	1LS-J550SE	1LS-J550K	1LS-J550G	1LS-J550GEC	1LS-J550SGEC	1LS-J550M	1LS-J550H	—
1LS-J50SEC	—	1LS-J50K	1LS-J50G	1LS-J50GEC	1LS-J50SGEC	—	1LS-J50H	—
1LS3-JSEC	1LS3-JSE	1LS3-JK	1LS3-JG	1LS3-JGEC	1LS3-JSGEC	1LS3-JM	1LS3-JH	1LS3-JL
1LS-J503SEC	1LS-J503SE	1LS-J503K	1LS-J503G	1LS-J503GEC	1LS-J503SGEC	1LS-J503M	1LS-J503H	1LS-J503L
1LS-J553SEC	—	1LS-J553K	1LS-J553G	1LS-J553GEC	1LS-J553SGEC	—	—	—
1LS10-JSEC	1LS10-JSE	1LS10-JK	1LS10-JG	1LS10-JGEC	1LS10-JSGEC	—	—	—
—	—	—	—	1LS2-JGEC	1LS2-JSGEC	1LS2-JM	1LS2-JH	—
—	—	1LS9-JK	—	1LS9-JGEC	1LS9-JSGEC	—	—	—
—	—	1LS-J501K	—	1LS-J501GEC	1LS-J501SGEC	—	—	1LS-J501L
1LS-J551SEC	—	—	—	1LS-J551GEC	1S-J551SGEC	—	—	—
—	—	1LS-J51K	—	1LS-J51GEC	1LS-J51SGEC	—	—	1LS-J51L
—	—	—	—	—	—	—	—	—
2LS1-JSEC	2LS1-JSE	2LS1-JK	2LS1-JG	2LS1-JGEC	2LS1-JSGEC	2LS1-JM	2LS1-JH	—
2LS-J6SEC	2LS-J6SE	2LS-J6K	2LS-J6G	2LS-J6GEC	2LS-J6SGEC	—	—	—
3LS1-JSEC	3LS1-JSE	3LS1-JK	3LS1-JG	3LS1-JGEC	3LS1-JSGEC	—	—	3LS1-JL
5LS1-JSEC	5LS1-JSE	5LS1-JK	5LS1-JG	5LS1-JGEC	5LS1-JSGEC	—	5LS1-JH	5LS1-JL
5LS7-JSEC	5LS7-JSE	5LS7-JK	5LS7-JG	5LS7-JGEC	5LS7-JSGEC	—	—	—
6LS1-JSEC	6LS1-JSE	6LS1-JK	6LS1-JG	6LS1-JGEC	6LS1-JSGEC	—	—	—
6LS3-JSEC	—	6LS3-JK	6LS3-JG	6LS3-JGEC	6LS3-JSGEC	—	—	—
8LS3-JSEC	—	8LS3-JK	8LS3-JG	8LS3-JGEC	8LS3-JSGEC	—	8LS3-JH	—
8LS125-JSEC	8LS125-JSE	8LS125-JK	—	8LS125-JGEC	8LS125-JSGEC	—	—	—
8LS152-JSEC	8LS152-JSE	8LS152-JK	—	8LS152-JGEC	8LS152-JSGEC	—	—	8LS152-JL

●Connector type switch body

Actuator		Operating characteristics			Options			
		Max. O.F. (operating) force	Max. P.T. (pretravel)	Min. T.T. (total travel)	Connector +LED EC-PD	Preleaded connector +LED EC-PD03	Connector+ double seal+LED SEC-PD	Preleaded connector +dbl seal+LED SEC-PD03
Name	Shape							
Roller lever		13.4N	Standard model 20°	Standard travel 50°	1LS1-JEC-PD	1LS1-JEC-PD03	1LS1-JSEC-PD	1LS1-JSEC-PD03
			High sensitivity 5°	Standard travel 35°	1LS19-JEC-PD	1LS19-JEC-PD03	1LS19-JSEC-PD	1LS19-JSEC-PD03
		8.9N	Standard model 20°	High overtravel 75°	1LS-J500EC-PD	1LS-J500EC-PD03	1LS-J500SEC-PD	1LS-J500SEC-PD03
			High sensitivity 10°	High overtravel 75°	1LS-J550EC-PD	1LS-J550EC-PD03	1LS-J550SEC-PD	1LS-J550SEC-PD03
Roller plunger		26.7N	1.7 mm	7.3 mm	5LS1-JEC-PD	5LS1-JEC-PD03	5LS1-JSEC-PD	5LS1-JSEC-PD03
Boot seal roller plunger		15.7N	1.7 mm	7.3 mm	5LS7-JEC-PD	5LS7-JEC-PD03	5LS7-JSEC-PD	5LS7-JSEC-PD03

●Resin filled type

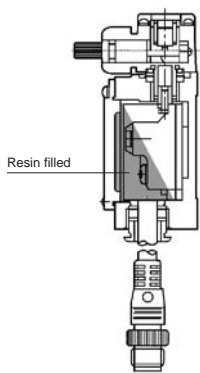

Resin filling

- Double-seal type has a sealed internal switch
- Places where coolant might seep, like the body cover and conduit, are filled with epoxy resin.
- Resin filling plus an ultra long life limit switch, for enhanced reliability.

		PT	TT	Base catalog listing	Catalog listing		
					DC preleaded connector, 30cm + LED	DC preleaded connector, 30cm	Preleaded connector with 4 assignable pins, 30cm + LED
Standard LS	Roller lever	Standard model 20°	75°	1LS-J500	1LS-J500SEC-MD03	1LS-J500S-MD03	1LS-J500SEC-MP03
		High sensitivity 10°	72°	1LS-J550	1LS-J550SEC-MD03	1LS-J550S-MD03	1LS-J550SEC-MP03
	Roller plunger	1.7mm	7.3mm	5LS1-J	5LS1-JSEC-MD03	5LS1-JS-MD03	5LS1-JSEC-MP03
	Boot seal roller plunger	1.7mm	7.3mm	5LS7-J	5LS7-JSEC-MD03	5LS7-JS-MD03	5LS7-JSEC-MP03
Long life LS	Roller lever	Standard model 20°	50°	1LS-J700	1LS-J700SEC-MD03	1LS-J700S-MD03	1LS-J700SEC-MP03
		High sensitivity 5°	35°	1LS-J710	1LS-J710SEC-MD03	1LS-J710S-MD03	1LS-J710SEC-MP03
		Standard model 20°	75°	1LS-J720	1LS-J720SEC-MD03	1LS-J720S-MD03	1LS-J720SEC-MP03
		High sensitivity 10°	72°	1LS-J730	1LS-J730SEC-MD03	1LS-J730S-MD03	1LS-J730SEC-MP03

Note: Specifications and dimensions are the same as those of the base catalog listing.

ELECTRICAL RATING

●2-circuit double break

Indicator type	None		100/200Vac with neon lamp		12 to 125Vac/dc with LED lamp	
Model	Catalog listing	Electrical rating	Catalog listing	Electrical rating	Catalog listing	Electrical rating
General-purpose	<input type="checkbox"/> LS <input type="checkbox"/> -J	125, 250, 480Vac 10A 125Vac 1/2HP 250Vac 1HP 125Vdc 0.8A 250Vdc 0.4A	<input type="checkbox"/> LS <input type="checkbox"/> -JE	125, 250Vac 5A	<input type="checkbox"/> LS <input type="checkbox"/> -JEC	125Vac 5A 125Vdc 0.8A
General-purpose, double seal	<input type="checkbox"/> LS <input type="checkbox"/> -JS	125, 250Vac 5A 125Vac 1/8HP 250Vac 1/4HP 125Vdc 0.8A 250Vdc 0.4A	<input type="checkbox"/> LS <input type="checkbox"/> -JSE	125, 250Vac 5A	<input type="checkbox"/> LS <input type="checkbox"/> -JSEC	125Vac 5A 125Vdc 0.8A
General-purpose, gold plated contacts	<input type="checkbox"/> LS <input type="checkbox"/> -JK	125Vac 0.1A 30Vdc 0.1A	<input type="checkbox"/> LS <input type="checkbox"/> -JKE	125Vac 0.1A	<input type="checkbox"/> LS <input type="checkbox"/> -JKEC	125Vac 0.1A 30Vdc 0.1A
General-purpose (high sensitivity)	1LS19-J 1LS-J55 <input type="checkbox"/>	125, 250, 480Vac 10A 125Vac 1/8HP 250Vac 1/4HP 125Vdc 0.4A 250Vdc 0.2A	1LS19-JE 1LS-J55 <input type="checkbox"/> E	125, 250Vac 5A	1LS19-JEC 1LS-J55 <input type="checkbox"/> EC	125Vac 5A
General-purpose (high sensitivity), dbi seal	1LS19-JS 1LS-J55 <input type="checkbox"/> S	125, 250Vac 5A 125Vac 1/8HP 250Vac 1/4HP	1LS19-JSE 1LS-J55 <input type="checkbox"/> SE	125, 250Vac 5A	1LS19-JSEC 1LS-J55 <input type="checkbox"/> SEC	125Vac 5A
General-purpose, DC connector/ preloaded connector	—	—	—	—	<input type="checkbox"/> LS <input type="checkbox"/> -JEC-PD <input type="checkbox"/> LS <input type="checkbox"/> -JEC-PD03	30Vdc 3A
General-purpose, AC connector/ preloaded connector	—	—	—	—	<input type="checkbox"/> LS <input type="checkbox"/> -JEC-PA <input type="checkbox"/> LS <input type="checkbox"/> -JEC-PA03	125Vac 3A 30Vdc 3A

●EN/GB-compliant model ratings (G type, with ground terminal)

	Application category	Rating	Rated thermal current (Ith)
Standard load type	AC-15	3.0A 240Vac	10A
	DC-12	0.4A 30Vdc	10A
Low current load type	AC-12	0.1A 125Vac	1A
	DC-12	0.1A 30Vdc	1A

●Reference rating (Ratings fluctuate according to the operating environment and type of load. Verify values on an actual operating unit.)

AC rating	125Vac				250Vac				480Vac	
Typical model: 1LS1-J	Resistance	Induction	Electric motor		Resistance	Induction	Electric motor		Resistance	Induction
	10	6	N.C.	N.O.			N.C.	N.O.		
DC rating	8Vdc		14Vdc		30Vdc		115Vdc		230Vdc	
Typical model: 1LS1-J	Resistance	Induction	Resistance	Induction	Resistance	Induction	Resistance	Induction	Resistance	Induction
	10	6	10	6	6	4	0.8	0.2	0.4	0.1

Note: "Induction" refers to a load having a power factor of 0.4 and time constant of 7ms (DC). "Electric motor" refers to a load having a value of six times the inrush current.

LIFE VS. LOAD CURRENT CHARACTERISTICS

● 1LS□-J/5LS□-J

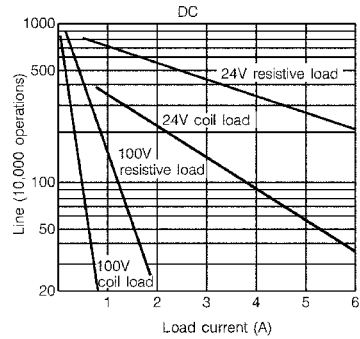
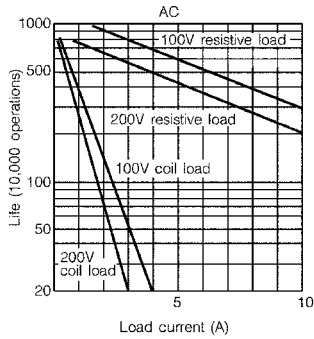



Operating frequency 1,800 operations/h

CONNECTORS

● LS Series connectors

Models (e.g. 2LS□-J□, 8LS□-J) for which a complete model No. is not given can be modified into the connector type by attaching the separate parts indicated below to a standard LS Series body.

Catalog listing	Name	Appearance	Power supply	Number of leads	
				2 leads	4 leads
LS-PA5A2	PA5 Series sealed connector with cable	  2-lead type 4-lead type	AC	○	—
LS-PA5A4				—	○
LS-PA5D2			DC	○	—
LS-PA5D4				—	○

Assembly method

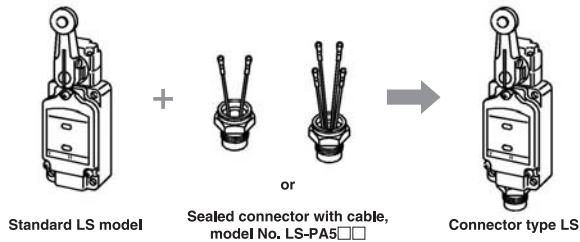

Wiring method

2-lead type: catalog listing LS-PA5□2

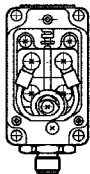

N.O. wiring



N.C. wiring * Note

4-lead type: catalog listing LS-PA5□4

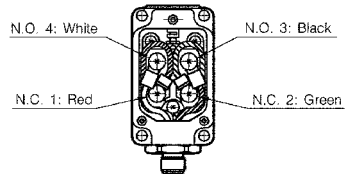



Connector		Internal switch
Contact No.	Lead color	Terminal No.
1	—	—
2	—	—
3	Black	NO.3
4	White	NO.4

Connector		Internal switch
Contact No.	Lead color	Terminal No.
1	Red	NO.1 (N.C.)
2	Green	NO.2 (N.C.)
3	Black	NO.3 (N.O.)
4	White	NO.4 (N.O.)

*Even in an N.C. wiring connection, N.C. contact assignments are Nos. 3 and 4.

●Preleaded connector for LS Series

Models (e.g. 2LS□-J□, 8LS□-J) for which a complete model No. is not given can be modified into the preleaded connector type by attaching the separate parts indicated below to a standard LS Series body.

Catalog listing	Name	Appearance	Power supply	Cable length	Number of leads
PA5-4IBX03HK4-E	PA5 Series connector cable		DC	30cm	4
PA5-4JBX03HK4-E			AC		
PA1-A10PF	Sealed connector		—	—	—

Assembly method

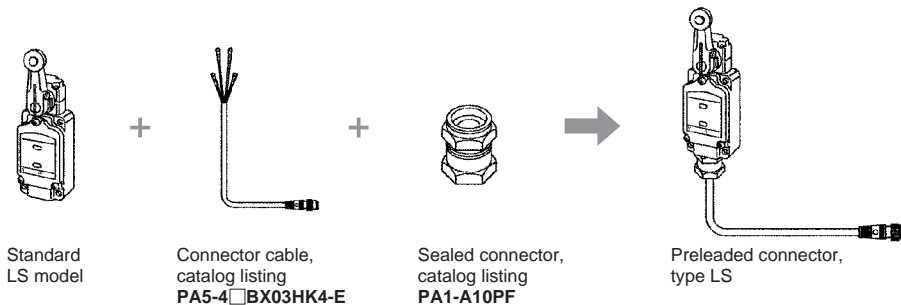

Wiring method

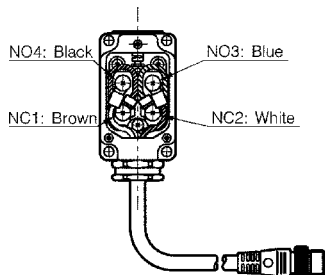



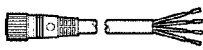

●PA5 connectors for connector-type limit switches

Appearance	Power supply	Cable features	Cable length	Catalog listing	Lead color
	DC	Oil-resistant, flexible UL2464 flame-resistant, EN-compliant	2m	PA5-4ISX2MK-E	1: brown, 2: white, 3: blue, 4: black
			5m	PA5-4ISX5MK-E	1: brown, 2: white, 3: blue, 4: black
	AC		2m	PA5-4JSX2MK-E	1: brown, 2: white, 3: blue, 4: black
			5m	PA5-4JSX5MK-E	1: brown, 2: white, 3: blue, 4: black

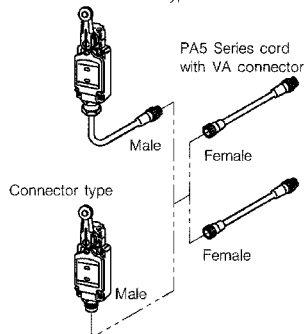
●Contact pin layout and lead color

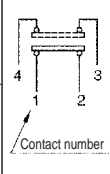
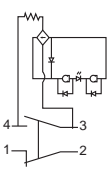
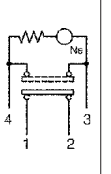
Pre-leaded connector type



Connector cable	Connector appearance		Pin layout			
			Without indicator lamp	With LED indicator lamp	With neon indicator lamp	Lead colors
AC cable: -PA -PA03	Switch side (male)	Connector side (female)				1: brown (N.C.) 2: white (N.C.) 3: blue (N.O.) 4: black (N.O.)
DC cable: -PD -PD03	Switch side (male)	Connector side (female)				

Note: The shape of the connector plugs and sockets is different for AC and DC cables, which are not mutually compatible.

The contact assignments of limit switches comply with Nippon Electric Control Equipment Industries Association standards (NECA 4202).

●Connector section specifications^{*1}

Item	Details	
Operating voltage/ current range	For AC type	Min. 5V 5mA. Max. 250Vac 3A.
	For DC type	Min. 5V 5mA. Max. 125Vdc 3A.
Insulation resistance	Min. 100MΩ (by 500Vdc megger)	
Dielectric strength	1,500Vac for 1 minute (between contacts, and between contacts and connector housing)	
Initial contact resistance	Max. 40mΩ (when 3A current is supplied to connected male and female connectors. Semiconductor lead-specific resistance not included)	
Mating/unmating force	0.4 to 4.0N per contact	
Mating cycles	50	
Connector nut tightening torque	Max. 0.8N·m ²	
Cable pullout strength	Min. 100N	
Vibration resistance	10 to 55Hz, 1.5mm peak-to-peak amplitude, 2 hours each in X, Y and Z directions	
Impact resistance	300m/s ² , 3 times each in X, Y and Z directions	
Protective structure	IP67 (IEC 529)	
Operating temperature	-10 to +70°C (freezing not allowed)	
Storage temperature	-20 to +80°C	
Operating humidity	Max. 95% RH	
Material	Contact	Gold-plated brass
	Contact holder	Glass-lined polyester resin
	Housing	Polyester elastomer
	Coupling	Brass (For DC, Ni-plated. For AC, orange coating)
O-ring	NBR (nitrile rubber)	
Recommended tightening torque	0.4 to 0.6N·m	
Connector cable	Catalog listing for DC	PA5-4ISX□MK-E ^{*3}
	Catalog listing for AC	PA5-4JSX□MK-E ^{*3}
	Nominal cross-sectional area, No. of leads	
	0.5mm ² , 4 leads	

*1. Specifications assume the use of a Yamatake connector (PA5 Series), and apply to 2-circuit double break switches (general-purpose and ultra long-life types).

*2. Tighten firmly by hand. If the connector is not tightened firmly, IP67 protection may be lost, or the connector may come loose.

*3. The number corresponding to □ in the catalog listing indicates the cable length (2 = 2m, 3 = 3m, and 5 = 5m).

●Connector dimensions

Sealed connector with LS-PA5□2 2-lead cable

(unit: mm)

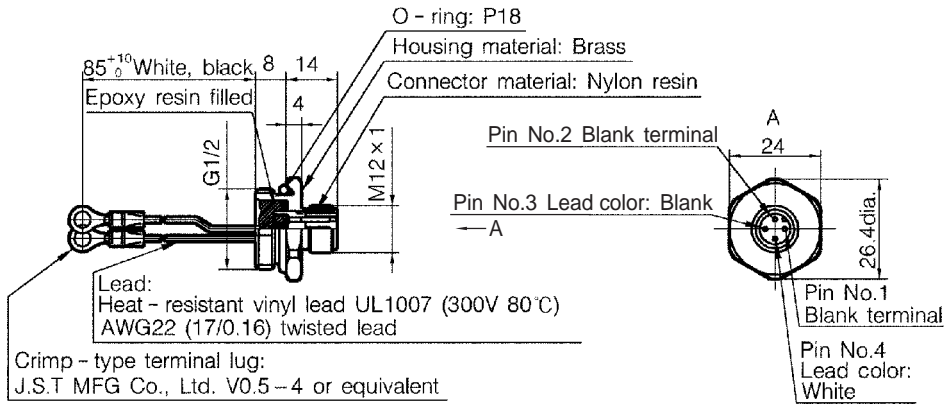

Sealed connector with LS-PA5□4 4-lead cable

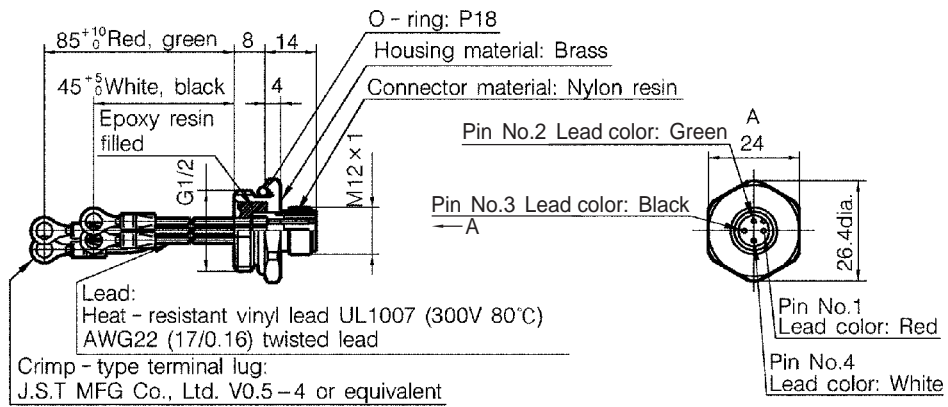

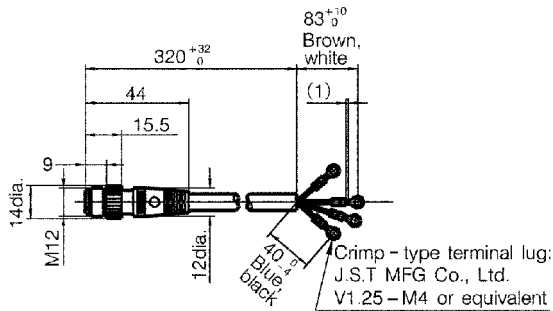

PA5-4□BX03HK4-E connector cable

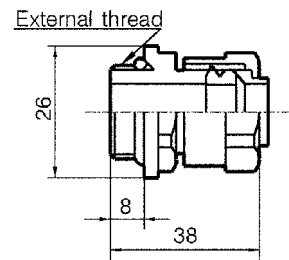

PA1-A10PF sealed connector

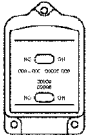

INDICATOR LAMP

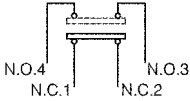
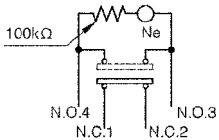
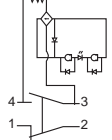
Option	Without indicator lamp	With 100/200Vac neon lamp	With 12 to 125V LED lamp for AC or DC
Catalog listing	□LS□-J	□LS□-JE	□LS□-JEC
Lamp cover front side	—		
Circuit diagrams			
Notes	—	Notes To ensure lighting of the neon lamp, use 75Vac min.	Notes The voltage indicator lamp (red LED) is 12 to 125V. The indicator lamp operates on either AC or DC power.
Lamp cover catalog listing (replacement part)		LS-29PA1	LS-29PAEC
Specifications	Operating voltage	100 to 200Vac	12 to 125V, AC or DC
		100Vac	200Vac
	Thermal current	Approx. 0.5mA	Approx. 1.5mA
	Resistance	100kΩ	33kΩ

● Connection/operation of lamp cover

When set to light in FREE position

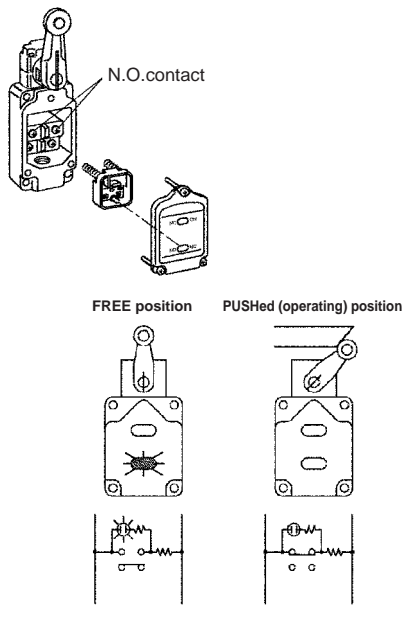

When set to light in PUSHed (operating) position (PUSH)

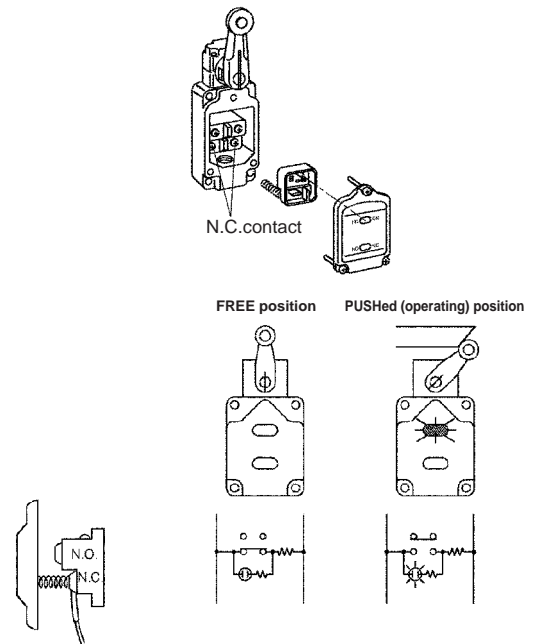

Series connection

Up to six switches can be connected in series when the power is 100V. Programmable controllers can also be connected in series. The brightness of the LED lamp is fixed regardless of the power, as light is generated by a built-in fixed current diode. (Note that neon lamp type "E" Series switches cannot be connected in series at 100V.)

PC connection possible

The leakage current when the limit switch is not operating is 0.6mA maximum. The PC will not malfunction due to dim lighting of the LED. Moreover, a fixed-current diode is built in to ensure fixed LED brightness regardless of the voltage.

Roller lever type



Standard type
Heat-resistant type
Cold-resistant type

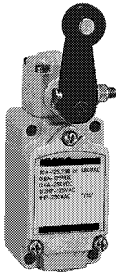

Corrosion-resistant type

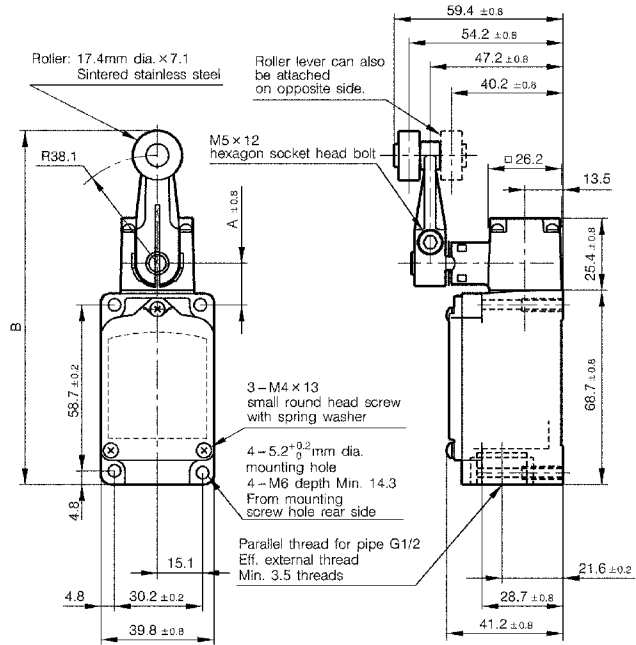

Catalog listing	2-circuit double break	Standard type (-10 to +70°C)	1LS1-J	1LS19-J	1LS-J500	1LS-J550	1LS-J50	
		Heat-resistant type (-10 to +120°C)	1LS1-JH	1LS19-JH	1LS-J500H	1LS-J550H	1LS-J50H	
		Cold-resistant type (-40 to +70°C)	1LS1-JL	1LS19-JL	1LS-J500L	—	—	
		Corrosion-resistant type (-10 to +70°C) ^{*1}	1LS1-JM	1LS19-JM	1LS-J500M	—	—	
Operating characteristics		Standard travel, standard characteristics	Standard travel, high sensitivity	High overtravel, standard characteristics	High overtravel, high sensitivity	High overtravel, 90° T.T.		
Certification		UL/CSA (excluding types H, L)					—	
O.F.	(Max. N)	13.4			8.9			
R.F.	(Min. N)	2.2			0.98		0.98	
P.T.	(Max. °)	20	5 ⁺² ₀	20	10 ⁺² ₋₁		30	
O.T.	(Min. °)	30	30	55	62		60	
M.D.	(Max. °)	12	3	12	5		15	
T.F.	(Max. N)	17.9		—	—		—	
Section A dimensions		14.7 ± 0.8					17.2 ± 0.8	
Section B dimensions		125 ^{REF}					127.5 ^{REF}	

Note *1. Exactly the same as 1LS1-J except for different lever shape. For details on the lever shape, see 6PA78-JM (page D-041).

Adjustable roller lever type

(unit: mm)

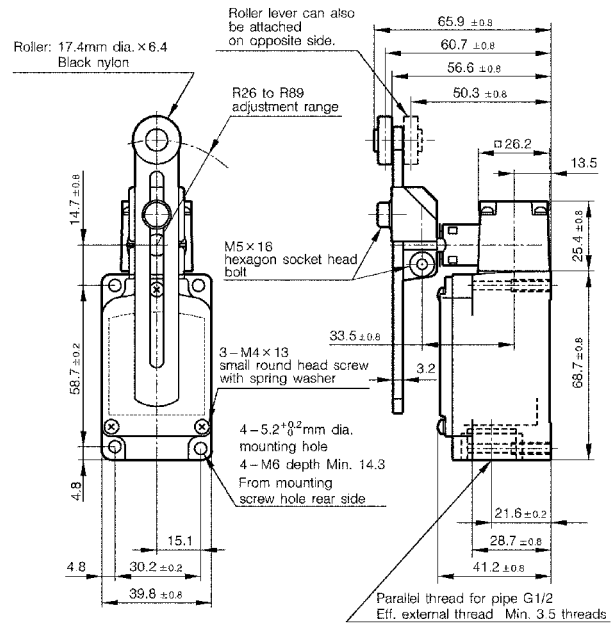
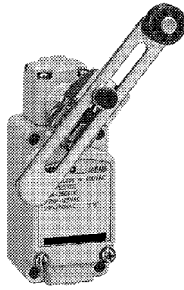

Catalog listing	Standard type	1LS3-J	1LS-J503	1LS-J553
Heat-resistant (-10 to +120°C)	—	—	1LS-J503H	—
Cold-resistant (-40 to +70°C)	1LS3-JL	1LS-J503L	—	—
Corrosion resistant	1LS3-JM	1LS-J503M	—	—
Operating characteristics	Standard travel, standard characteristics	High overtravel, standard	High overtravel, high sensitivity	
UL/CSA	○(excluding types H, L)			
*O.F. (Max. N)	13.4	8.9	8.9	
*R.F. (Min. N)	2.2	0.98	0.98	
P.T. (Max. °)	20	20	10 ⁺² / ₁	
O.T. (Min. °)	30	55	62	
M.D. (Max. °)	12	12	5	
*T.F. (Max. N)	17.9	—	—	

*At lever length of 38.1mm. Roller lever length can be adjusted from 26 to 89mm.

Light operation rod lever type

(unit: mm)

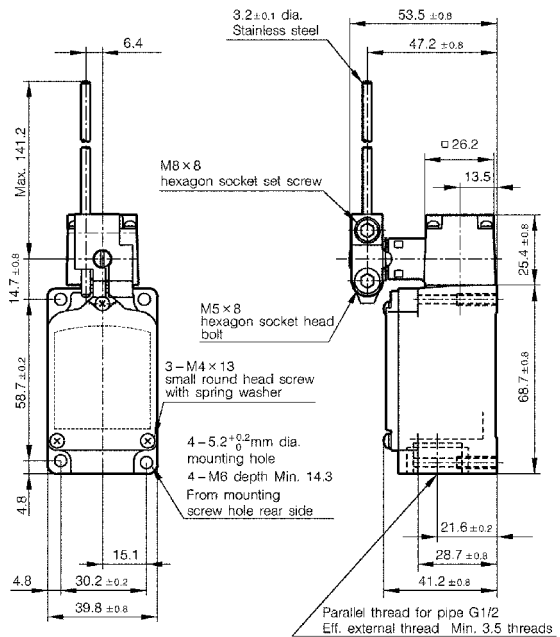
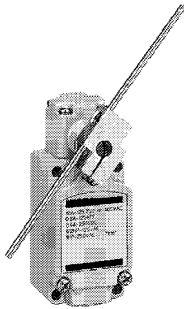

Catalog listing	1LS10-J
Operating characteristics	Standard travel, Standard characteristics
UL/CSA	○
*O.F. (Max. N)	1.4
*R.F. (Min. N)	0.27
P.T. (Max. °)	20
O.T. (Min. °)	30
M.D. (Max. °)	12
*T.F. (Max. N)	2.0

*At lever length of 141.2mm.

Fork lever lock operation type

(unit: mm)

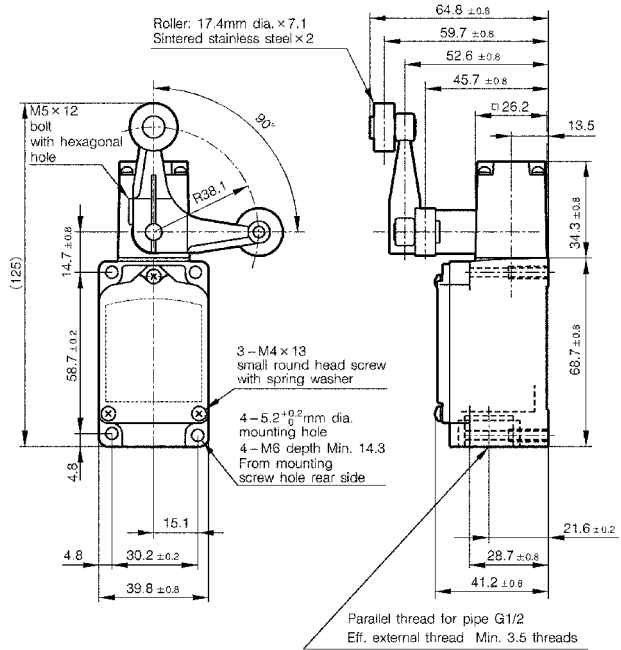
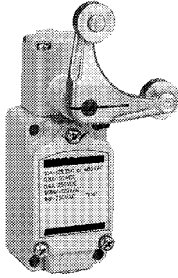

Actuator type	Fork lever lock operation type		
	Roller opposite side	Roller same side	No roller lever
Catalog listing	6LS1-J	6LS3-J	6LS2-J
UL/CSA	○		
O.F. (Max. N)	13.4		
P.T. (Max. °)	60		
O.T. (Min. °)	30		
T.T. (°)	90±10		
Mechanical reverse angle (° max)	55		

Note: Values for the lever-less type assume a lever length of 38.1mm.

Plunger type

(unit: mm)

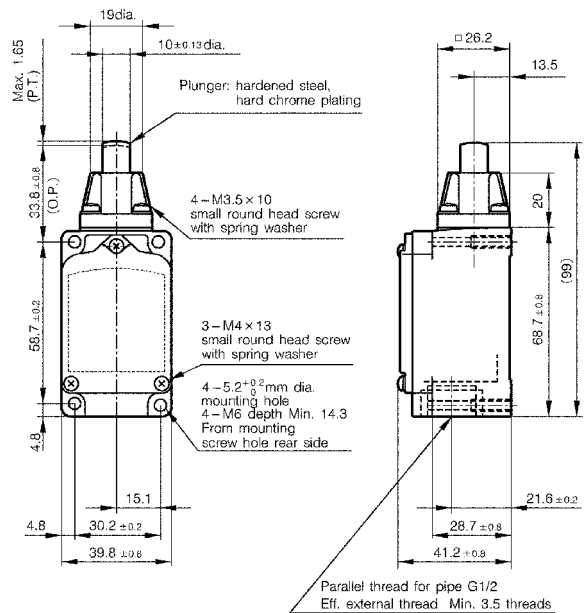
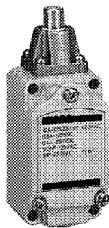

Catalog listing	Standard type	2LS1-J
	Heat-resistant	2LS1-JH
UL/CSA	○(excluding types H, M)	
O.F. (Max. N)	26.7	
R.F. (Min. N)	8.9	
P.T. (Max. mm)	1.65	
O.T. (Min. mm)	6.4	
M.D. (Max. mm)	0.51	

Ball plunger type

(unit: mm)

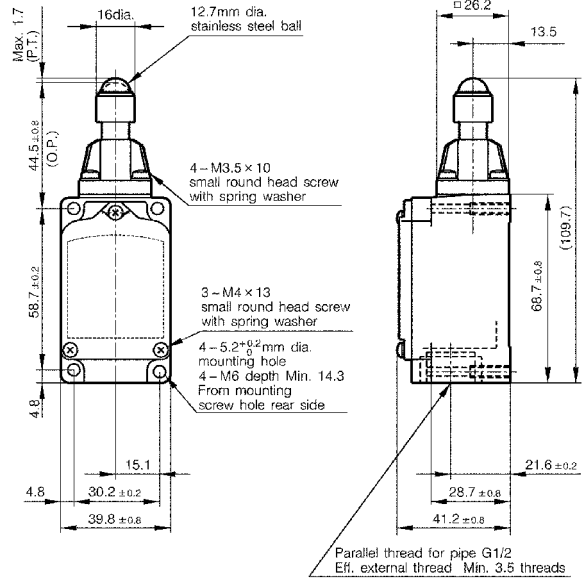
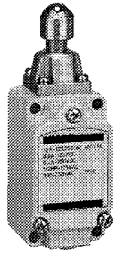

Catalog listing	2LS-J6
UL/CSA	○
O.F. (Max. N)	26.7
R.F. (Min. N)	8.9
P.T. (Max. mm)	1.7
O.T. (Min. mm)	4.0
M.D. (Max. mm)	0.51

Roller plunger type

(unit: mm)

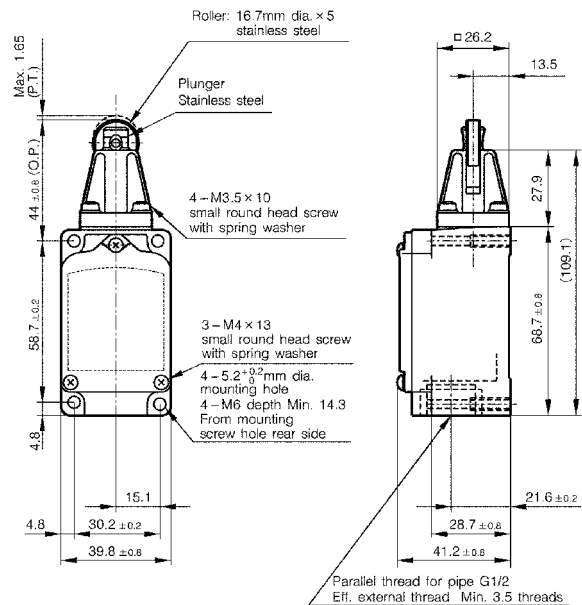
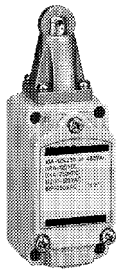

Catalog listing	Standard type	5LS1-J
	Heat-resistant	5LS1-JH
	Cold-resistant	5LS1-JL
UL/CSA	○(excluding types H, L)	
O.F. (Max. N)	26.7	
R.F. (Min. N)	8.9	
P.T. (Max. mm)	1.7	
O.T. (Min. mm)	5.6	
M.D. (Max. mm)	0.51	

Boot seal roller plunger type

(unit: mm)

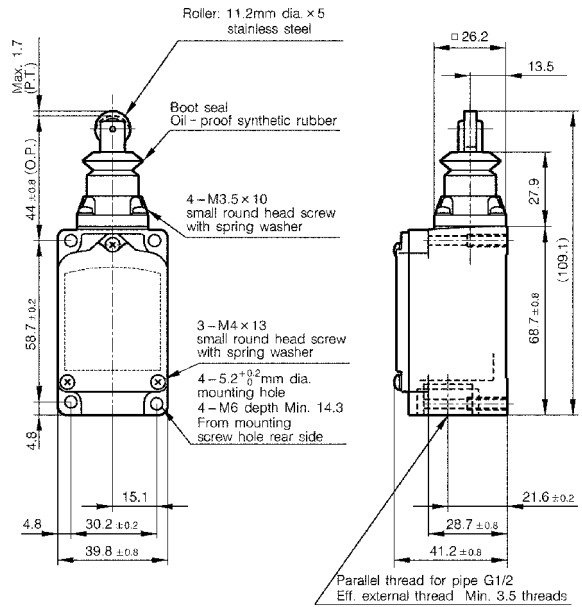
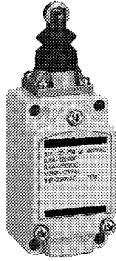

Catalog listing	5LS7-J
UL/CSA	○
O.F. (Max. N)	15.7
R.F. (Min. N)	4.4
P.T. (Max. mm)	1.7
O.T. (Min. mm)	5.6
M.D. (Max. mm)	0.51
R.T. (Min. mm)	0.38

Side roller plunger

(unit: mm)

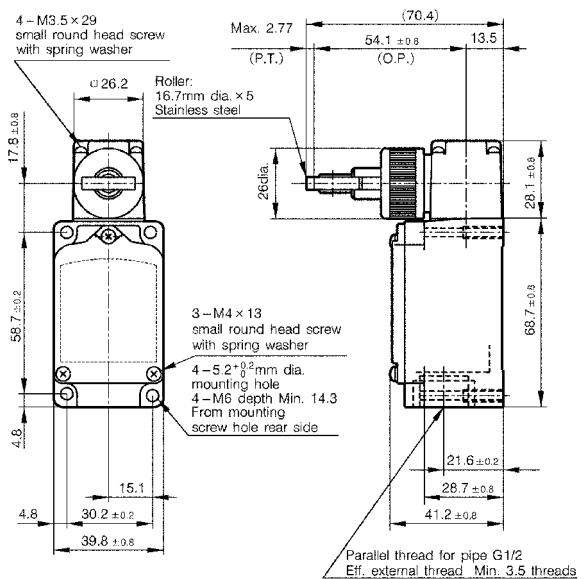
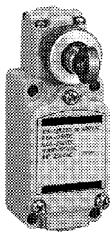

Catalog listing	3LS1-J
UL/CSA	○
O.F. (Max. N)	40.1
R.F. (Min. N)	8.9
P.T. (Max. mm)	2.77
O.T. (Min. mm)	5.6
M.D. (Max. mm)	1.02

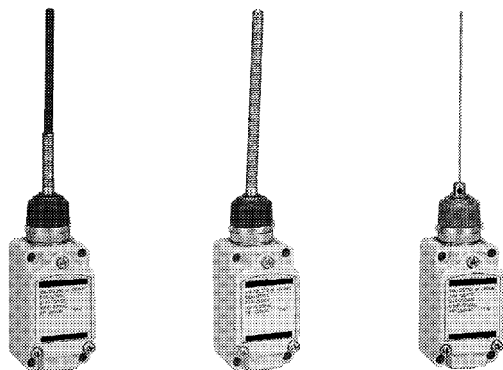

8LS3-J 8LS152-J 8LS125-J

Actuator type		Non-directional operation type		
		Spring rod	Coil spring	Steel wire
Catalog listing	Standard type	8LS3-J	8LS152-J	8LS125-J
	Heat-resistant	8LS3-JH	—	—
	Cold-resistant	—	8LS152-JL	—
UL/CSA		○(excluding H and L types)		
O.F. (Max. N)		1.4		0.28
P.T. (Max. mm)		28.6		55

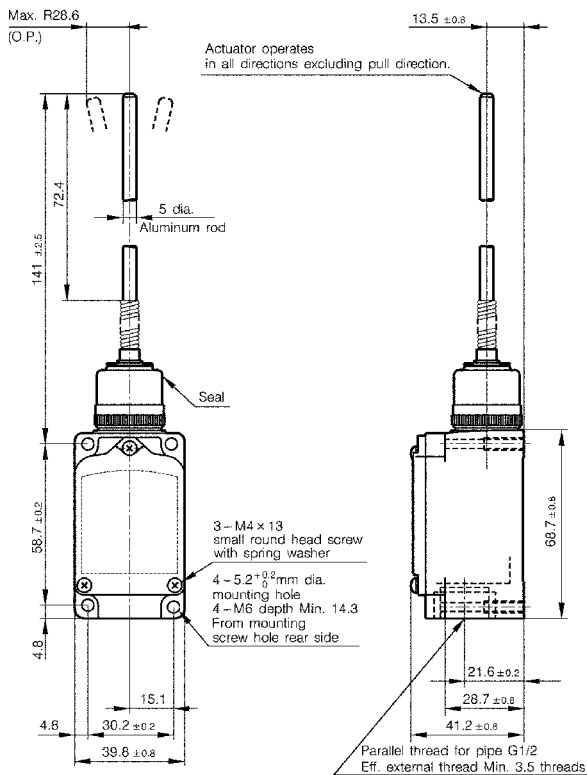

8LS3-J

8LS125-J

8LS152-J

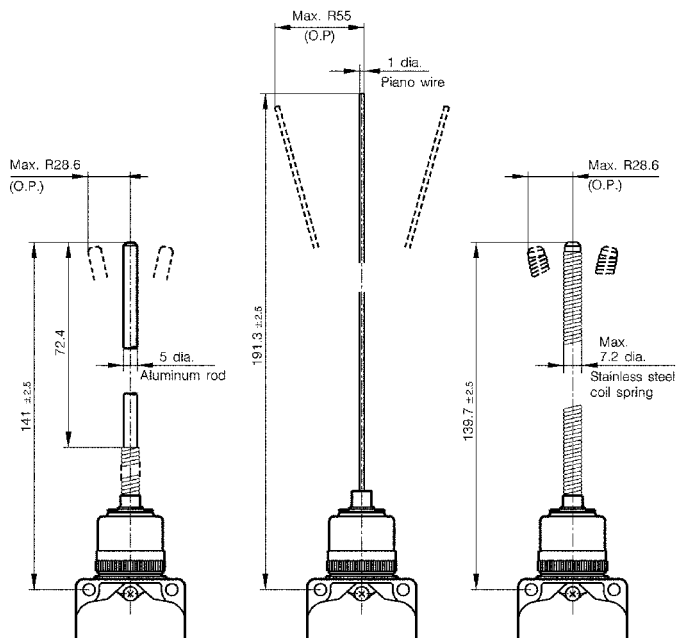

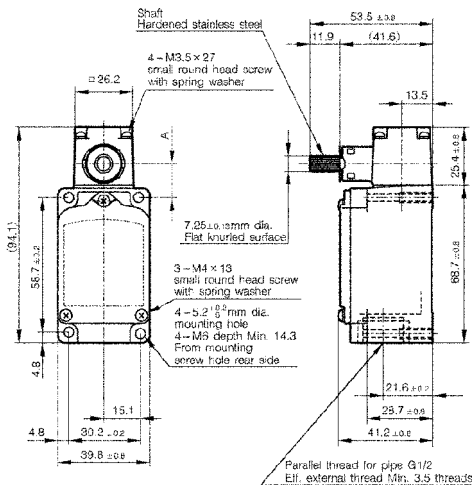
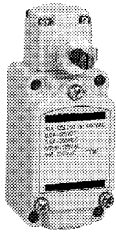

Catalog listing	Standard type	1LS2-J	1LS9-J	1LS-J501	1LS-J551	1LS23-J	1LS-J51
	Heat-resistant	1LS2-JH	—	—	—	—	—
	Cold-resistant	—	—	1LS-J501L	—	—	1LS-J51L
	Corrosion resistant	1LS2-JM	—	—	—	—	—
Operating characteristics	Standard travel, standard characteristics	Standard travel, high sensitivity	High overtravel, standard type	High overtravel, high sensitivity	Standard travel, light operation, standard characteristics	High overtravel, 90° T.T.	
Certification	UL/CSA (excluding types H, L)						
O.F. (Max. N•m)	0.52			0.34		0.22	0.34
R.F. (Min. N•m)	0.086			0.038		0.029	0.019
P.T. (Max. °)	20	5 ⁺² ₀	20	10 ⁺² ₀	20	30	
O.T. (Min. °)	30	30	55	62	30	60	
M.D. (Max. °)	12	3	12	5	12	15	
T.F. (Max. N•m)	0.69			—		0.29	—
Catalog listing with lever	1LS1-J	1LS19-J	1LS-J500	1LS-J550	1LS10-J	1LS-J50	
Section A dimensions				14.7±0.8		17.2±0.8	

Roller lever type with indicator lamp (typical catalog listing 1LS1-JEC)

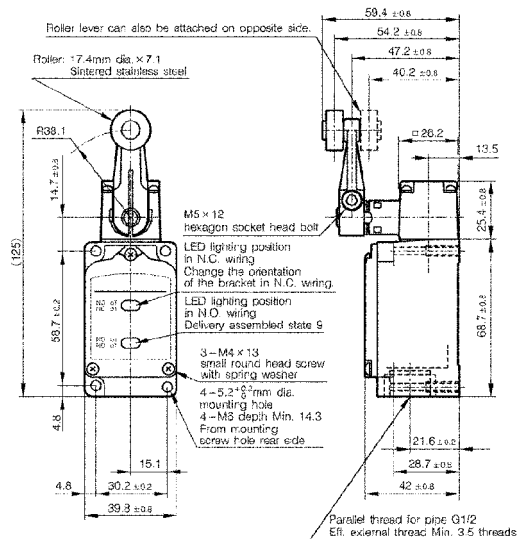
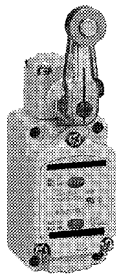

Catalog listing	1LS1-JEC	
UL/CSA	○	
O.F. (Max. N)	13.4	
R.F. (Min. N)	2.2	
P.T. (Max. °)	20	
O.T. (Min. °)	30	
M.D. (Max. °)	12	
T.F. (Max. N)	17.9	

*Values for other catalog listings are the same, although the actuators differ.

Boot seal roller plunger type

(unit: mm)

Basic catalog listing	5LS7-J	
Quick connector for DC	5LS7-JEC-PD	
O.F.	(Max. N)	15.7
R.F.	(Min. N)	4.4
P.T.	(Max. mm)	1.7
O.T.	(Min. mm)	5.6
M.D.	(Max. mm)	0.51

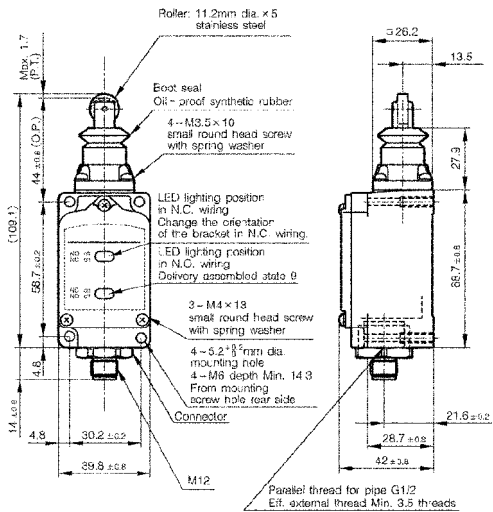

● **Preloaded connector type**

Roller lever type

(unit: mm)

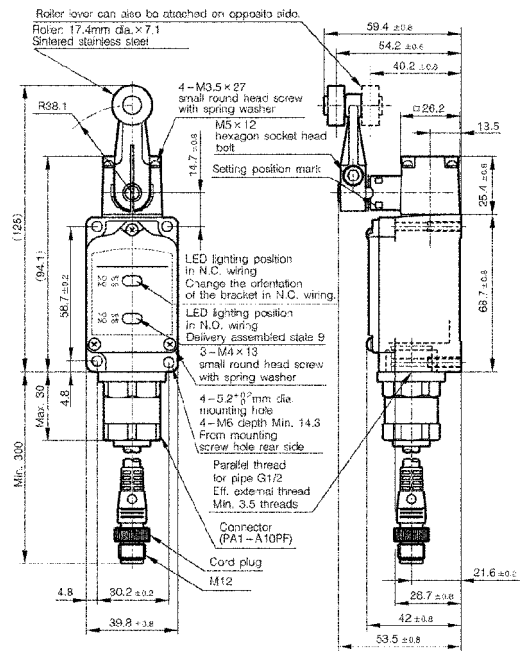

Basic catalog listing	1LS1-J	1LS19-J	1LS-J550
Preloaded connector for DC, cable length 0.3m	1LS1-JEC-PD03	1LS19-JEC-PD03	1LS-J550EC-PD03
Operating characteristics	Standard travel, standard characteristics	Standard travel, high sensitivity	High overtravel, high sensitivity
O.F.	(Max. N)	13.4	8.9
R.F.	(Min. N)	2.2	0.98
P.T.	(Max. °)	20	10 ⁺² ₀
O.T.	(Min. °)	30	62
M.D.	(Max. °)	12	3

Roller plunger type

(unit: mm)

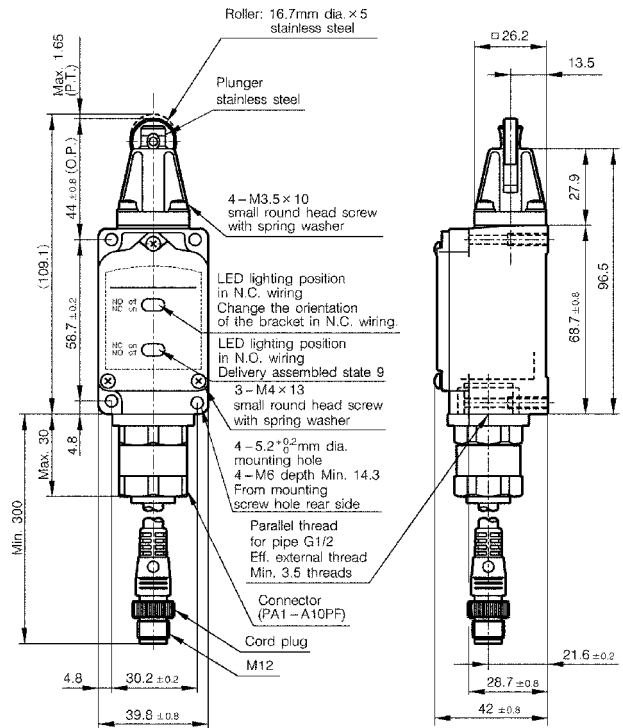

Basic catalog listing		5LS1-J
Preleaded connector for DC, cable length 0.3m		5LS1-JEC-PD03
O.F.	(Max. N)	26.7
R.F.	(Min. N)	8.9
P.T.	(Max. mm)	1.65
O.T.	(Min. mm)	5.6
M.D.	(Max. mm)	0.51

Boot seal roller plunger type

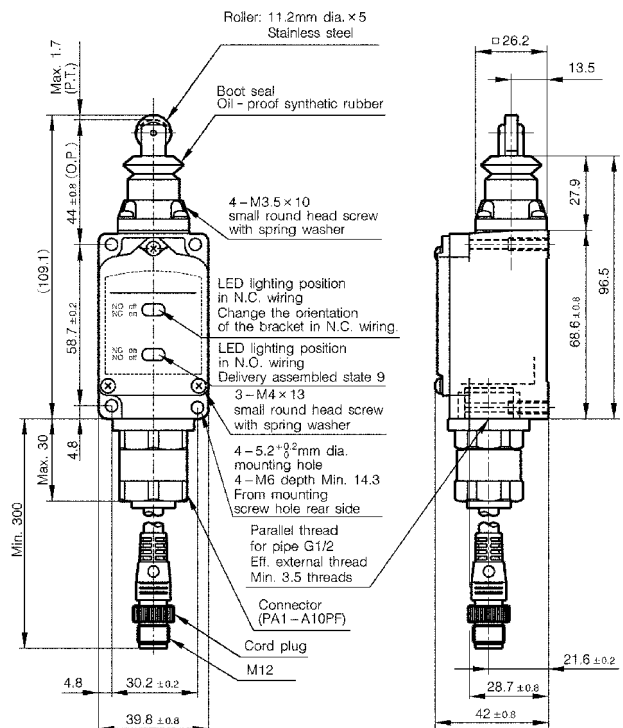

(unit: mm)



Basic catalog listing		5LS7-J
Preleaded connector for DC, cable length 0.3m		5LS7-JEC-PD03
O.F.	(Max. N)	15.7
R.F.	(Min. N)	4.4
P.T.	(Max. mm)	1.7
O.T.	(Min. mm)	5.6
M.D.	(Max. mm)	0.51

Auxiliary parts

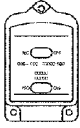









●Lamp cover

Catalog listing	LS-29PA1 (standard type)	LS-9PAW (spatter-guarded)	LS-29PAEC (standard type)	LS-9PAWC (spatter-guarded)
Specifications	Neon lamp for 100/200Vac		LED lamp for 12 to 125Vac/dc	
Appearance				

●Shaft cover

Catalog listing	Material	Shape
PA-J206	NBR	
PA-J252	Silicone rubber	(10 pieces per set)

●Auxiliary actuators

Catalog listing	Appearance	Compatible switch	Lever length(mm)	Lever tightening method and material
6PA78-J		1LS Series	38.1	M5 hexagon socket head bolt. Chrome molybdenum steel.
6PA-J148				M5 hexagon socket head bolt. Stainless steel.
6PA78-JW (spatter-guarded)				M5 lock nut. Distance across flats 8mm. Stainless steel.
6PA78-JM (stainless steel)				M5 double lock nut. Distance across flats 8mm. Stainless steel.
6PA-J45				
6PA-J45W (spatter-guarded)				
LS-6PA79-201			50	M5 hexagon socket head bolt. Stainless steel.
PA-J11			60	M5 hexagon socket head bolt. Chrome molybdenum steel.
6PA44-J			26 to 89	M5 hexagon socket head bolt. Chrome molybdenum steel.
LS-6PA58				M5 hexagon socket head bolt. Stainless steel.
6PA-J54			26 to 89	M5 double lock nut. Distance across flats 8mm. Stainless steel.
6PA63-J			304.6	M5 hexagon socket head bolt. Chrome molybdenum steel.
6PA-J40			255	M5 lock nut. Distance across flats 8mm.
6PA43-J		1LS10-J Series	141.2 max.	M5 hexagon socket head bolt. Chrome molybdenum steel.
6PA-J176				M5 hexagon socket head bolt. Stainless steel.
6PA74-J (rollers on same side)		6LS Series	38.1	M5 hexagon socket head bolt. Chrome molybdenum steel.
6PA80-J (rollers on both sides)				M5 hexagon socket head bolt. Chrome molybdenum steel.

Lamp cover

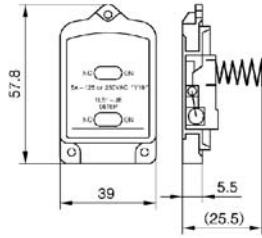

**LS-29PA1, LS-9PAW
LS-29PAEC, LS-9PAWC**

Auxiliary actuators

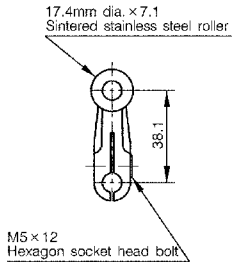

**6PA-J148, 6PA78-J
6PA78-JW**

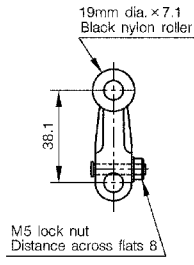

6PA78-JM

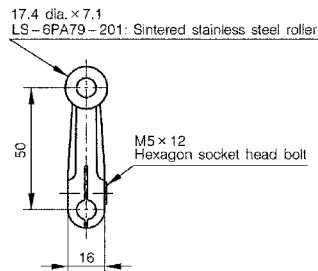

LS-6PA79-201

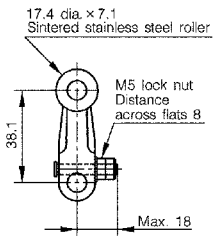

**6PA-J45
6PA-J45W**

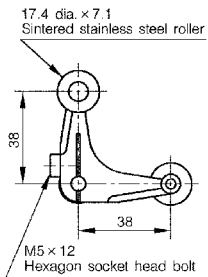

6PA80-J

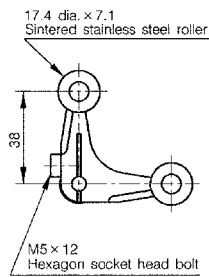

6PA74-J

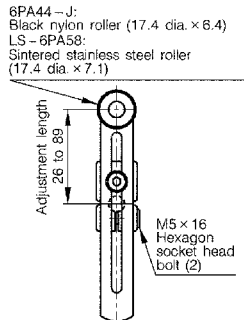

**6PA44-J
LS-6PA58**

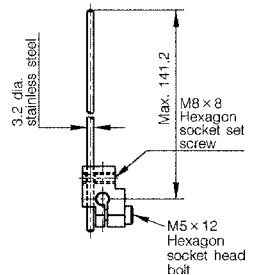

**6PA43-J
6PA-J176**

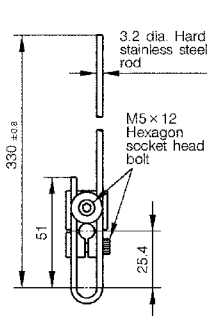

6PA63-J

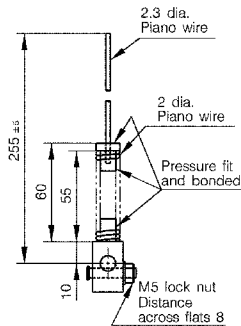

6PA-J40

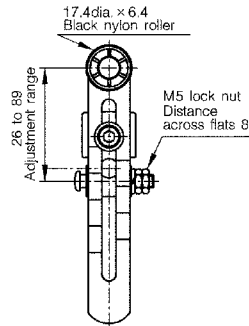

6PA-J54

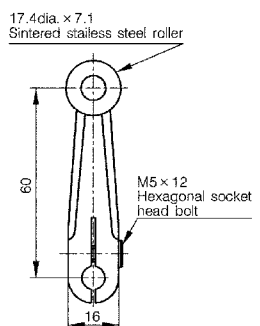

PA-J11

WHEN USING LS SERIES LIMIT SWITCHES

1. Changing the position of the operating head

The operating head can be set to four positions. To set to the desired position, remove the four head tightening screws and rotate the head 90° to one of the four different positions. When changing the direction of the operating head, change the direction of the internal plunger at the same time. The roller plunger can be set to one of two different positions 90° apart.

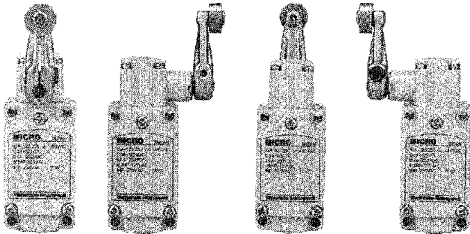

2. Changing the operating direction of roller lever type

The operation direction can be set to three sequences (excluding 1LS-J500, 1LS-J550 and 1LS-J50). Lever type limit switches can be set to operate electrically when moved either clockwise or counterclockwise by changing the direction of the internal stepped plunger.

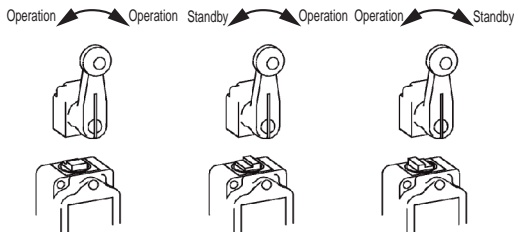

3. Indicating the operation set position on the roller lever type

Excessive or insufficient pushing of the lever can be eliminated to ensure stable prolonged use by setting so that the pointer that rotates with the lever enters the head's protrusion zone. The position of the protrusion zone varies with different model types, such as standard, high sensitivity, and 90° T.T. types.

3.1 Standard type (1LS1-J□, 1LS-J50□Series)

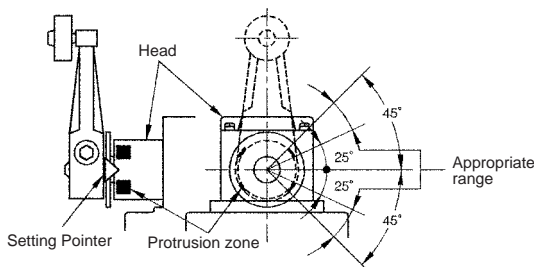

3.2 High-sensitivity type (1LS19-J□, 1LS-J55□Series)

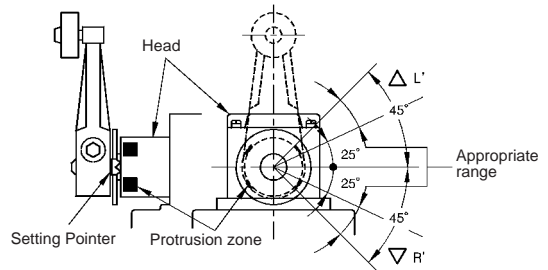

4. Indicating the operation set position of roller plunger type (5LS1-J□)

The indentation on the roller plunger is for preventing excessive or insufficient plunger operation. Determine the position of the actuating element so that the indentation on the plunger fits into the top surface of the bushing.

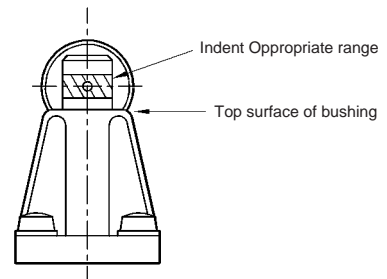

5. How to set the actuating element

5.1 Roller lever type

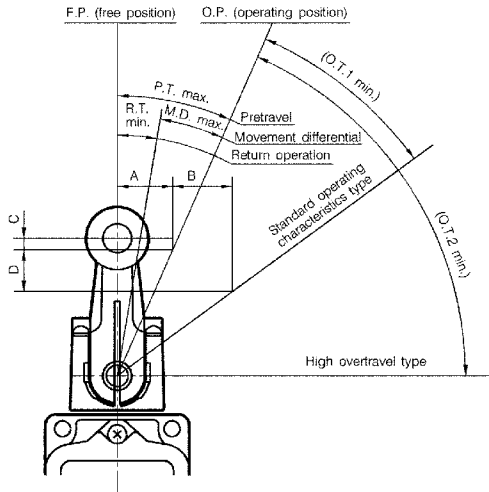

Symbol	Operating angle (°)				
Model	P.T.	O.T.1	O.T.2	R.T.	M.D.
1LS1-J□	20	30	—	5	12
1LS19-J□	5 ⁺² ₀	30	—	1.5	3
1LS-J500□	20	—	55	5	12
1LS-J550□	10 ⁺² ₋₁	—	62	5	5

Symbol	Operating force (N)			動作距離 (mm)			
	O.F.	R.F.	T.T.F.	A	B	C	D
1LS1-J□	13.4	2.2	17.9	13.0	16.1	2.3	11.3
1LS19-J□	13.4	2.2	17.9	3.3	18.5	0.1	6.7
1LS-J500□	8.9	0.98	—	13.0	23.8	2.3	25.9
1LS-J550□	8.9	0.98	—	6.6	29.6	0.6	25.7

Key to the abbreviations used in the above tables:

- P.T. : Pretravel
- O.T. 1 : Overtravel (standard switch)
- O.T. 2 : Overtravel (high overtravel switch)
- R.T. : Return operation
- M.D. : Movement differential
- O.F. : Operating force
- R.F. : Release force
- T.T.F. : Total travel force

5.2 Height from switch mounting hole to actuating element

Roller lever type

For roller lever type switches, we recommend setting the distance from the switch mounting hole to the actuating element as shown below.

Example: 1LS1-J (unit: mm)

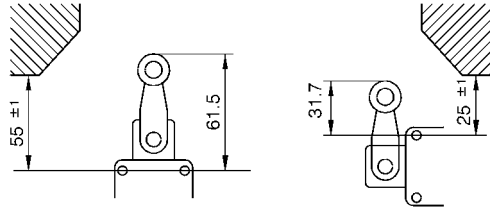

Roller plunger type

For roller plunger type switches, we recommend setting the distance from the switch mounting hole to the actuating element as shown below.

Example: 5LS1-J (unit: mm)

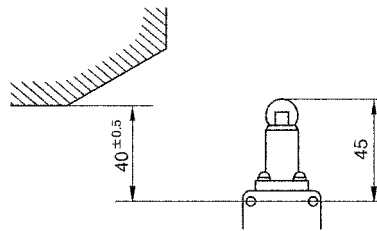

6. Handling the connector and prelead connector

6.1 Tightening the fixing cap ring and outside screw lock ring

If the screw of the mating part is made of resin, the threads can easily be damaged when the connector is first tightened. When assembling the connector, align the center of the cores, push in as far as possible, and then turn to tighten.

Be sure to tighten fully by hand. The recommended tightening torque is 0.4 to 0.6N·m. Use of a tightening tool may damage the connector. If the connector is not tightened firmly, IP67 protection may be lost, or the connector may come loose.

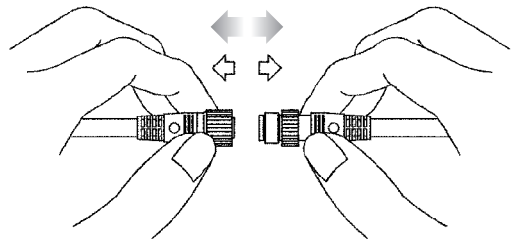

6.2 Inserting and removing connectors

Before inserting or removing connectors, be sure to turn the power OFF. When removing, hold the connector itself--do not pull by the cable.

6.3 Cautions when bending cables

The minimum bend radius (R) of the cable is 80mm. Allow sufficient cable for bends.

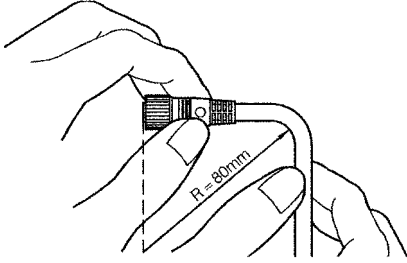

6.4 Installation of connector type switches

(unit: mm)

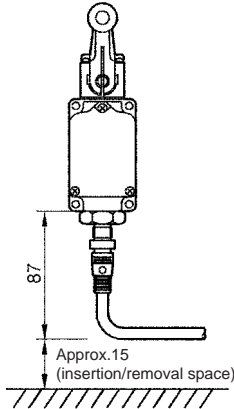

6.5 Cautions when replacing connectors

When removing connectors to replace the switch or cable, wipe the connector and the surrounding area thoroughly to remove any water. After removing the connector, do not allow it to be immersed in chemicals or powder, or to be dropped. If the connector is immersed in a fluid, allow it to fully dry before connecting again. If the connector is dropped in powder, wipe it off completely before connecting again. Failure to observe these precautions may result in a short circuit or a failed connection.

7. Other

7.1 Protective structure

- IP67 protection does not assure complete waterproofing. Switch should not be in constant contact with water.
- Avoid use where external force is applied at all times on the connecting section of the connector.
- Do not use the body as a step or place heavy objects on top of it.

7.2 Ensuring a good seal

- When general-purpose limit switches are used in locations subject to splashing by water, oil, dirt and dust, or chips, water or oil sometimes enters the switch from the conduit due to capillary action. For this reason, be sure to use a sealed connector compatible with the cable.
- When the screws in the head or covers are loosened to change the operating direction of the switch, or the relationship between switch operation and the indicator lamp (lamp ON during switch standby / during switch operation), tighten the screws to the recommended tightening torque to ensure a good seal.

Recommended tightening torque

Cover: 1.3 to 1.7N·m (M4 screw)

Head: 0.8 to 1.2N·m (M3.5 screw)

7.3 Attaching switches

- Tighten each of the parts on the limit switch according to the appropriate tightening torques listed in the performance tables. Overtightening damages screws and other parts. On the other hand, insufficient tightening of screws lowers the effectiveness of the seal and reduces various performance characteristics.
- Do not leave or use covers and conduit parts open. Water, dirt, or dust may enter, which causing malfunction.
- Prevent impact to the lever body and head. Failure to do so might deform the actuator or cause defective switch return.
- Do not use silicone rubber electrical lead insulation, silicone adhesive or grease containing silicone. Doing so might result in defective electrical conductivity.

7.4 Wiring

- Do not perform wiring with the power ON. Doing so might cause electric shock, or the machine may start unexpectedly, causing an accident.
- Use crimp-type terminal lugs with covered insulation for electrical leads to prevent contact with covers and housings. If a crimp-type terminal lug contacts a cover, the cover may no longer shut or a ground fault may occur.
- Use sealed connectors (PA1 Series, etc. sold separately) or flexible tubing (PA3 Series) with IP67 or equivalent seal for conduits.
- Firmly tighten covers and conduits. If covers and conduits are not sufficiently tightened, the seal will be impaired and switch performance will no longer be assured.

7.5 Adjusting switches

- Do not apply excessive force (5 times O.F.) to the actuator beyond the total travel position. Doing so might damage the switch.
- Keep overtravel between 1/3 to 2/3 of the rated value. Small overtravel might cause the contacts to rattle due to vibration and impact, or may result in defective contact.