

Explosion-Proof Packing Connectors (Standard)

Model no.	Protective pipe dimensions	Compatible cable diameter
2PA-JEX108L	G1/2	φ7.5~8.5
2PA-JEX109L		φ8.5~9.5
2PA-JEX110L		φ9.5~10.5
2PA-JEX111L		φ10.5~11.5
2PA-JEX112L		φ11.5~12.5
2PA-JEX113L		φ12.5~13.5
2PA-JEX208L	G3/4	φ7.5~8.5
2PA-JEX209L		φ8.5~9.5
2PA-JEX210L		φ9.5~10.5
2PA-JEX211L		φ10.5~11.5
2PA-JEX212L		φ11.5~12.5
2PA-JEX213L		φ12.5~13.5

Auxiliary Actuators

Type	Shape	Lever length	Model no.	Roller material	Lever material	Method of attaching lever
roller lever		38.1mm	6PA-J63	Black nylon	Corrosion-resistant aluminum	Hexagon socket head bolt
		38.1mm	6PA-J78	Brass	Corrosion-resistant aluminum	Hexagon head bolt
		38.1mm	LS-6PA44-002	Black nylon	Stainless	Hexagon socket head bolt
		38.1mm	LS-6PA44-004	Brass	Stainless	Hexagon socket head bolt
		30mm	6PA-J105	Black nylon	Corrosion-resistant aluminum	Hexagon socket head bolt
		30mm	LS-6PA107	Brass	Corrosion-resistant aluminum	Hexagon socket head bolt
		30mm	LS-6PA44-102	Black nylon	Stainless	Hexagon socket head bolt
		30mm	LS-6PA44-104	Brass	Stainless	Hexagon socket head bolt
Adjustable roller lever		26.0~89.0mm	6PA-J79	Black nylon	Stainless/ Corrosion-resistant aluminum	Hexagon socket head bolt
		26.0~89.0mm	6PA-J119	Brass	Stainless/ Corrosion-resistant aluminum	Hexagon socket head bolt

Please read the "Terms and Conditions" from the following URL before ordering or use:

<http://www.azbil.com/products/bi/order.html>

Specifications are subject to change without notice.

Yamatake Corporation
Advanced Automation Company

1-12-2 Kawana, Fujisawa
Kanagawa 251-8522 Japan
URL:<http://www.azbil.com/>

Printed in Japan. (ED)
1st Edition: Issued in Jan.2011

No part of this publication may be reproduced or duplicated without the prior written permission of Yamatake Corporation.

Explosion-Proof Switches Compliant with IEC Standards

Vertical Explosion-Proof Switches

LX7000 Series

2-Point Detection Explosion-Proof Switches

VCX-7000 Series

Ex d e IIC T6 certified



Meets Global Standards

Limit Switches Compliant with IEC Explosion-Proof Standards



Meeting global standards through continued safe and reliable product performance

Through a combination of explosion-proof internal switches and a housing with an increased-safety explosion-proof structure, these limit switches have been certified as explosion-proof (Ex de IIC T6).

Product Lineup

A wide range of actuators

The roller lever actuator can be used in combination with all general-purpose limit switch levers.

Compliant with a range of cable lead-in types

- Conduit type: screw-in conduit and lead-in insulated cable
- Packing type (TIIS explosion-proof product) : cable lead-in using explosion-proof packing connectors
- For products that have been certified as explosion-proof by international standards, metric fine screw threads[※] are also available for use in combination with cable glands that comply with IEC explosion-proof standards.

[※]M20×1.5 for the LX7000 series, and M25×1.5 for the VCX-7000 series.

IEC Explosion-Proof Standards Compliance

IEC explosion-proof standards are increasingly being accepted as global standards. Because we ensure compliance with IEC standards, our switches have also been certified as meeting Japanese explosion-proof standards, as well as those of other areas such as Europe and Asia (China, South Korea).

External Standards

	TIIS/NK (Japan)	NEPSI (China)	KOSHA (South Korea)	ATEX (Europe)	IECEX ^(※)
LX7000 series	●	●	●	●	●
LX7000-R series	●	—	—	—	—
VCX-7000 series	●	●	●	●	●
VCX-7000-R series	●	—	—	—	—

[※]IECEX: Valid in certain IECEX member countries. Please check whether applicable.

Outstanding Explosion-Proof Performance

Ex de IIC T6 certified

By combining internal switches having an explosion-proof structure with a housing having an increased-safety explosion-proof structure, these switches meet IIC T6 explosion-proof standards and can be used in hydrogen gas atmospheres. They can also be used in Zone 1 (hazardous area) applications.

Explosion-Proof Performance: IEC Explosion-Proof Standards Explosive Gas Group Classification and Temperature Levels

Temperature level	T1	T2	T3	T4	T5	T6
Maximum surface temperature of electrical device	450°C	300°C	200°C	135°C	100°C	85°C
Technological standards (group classification)	IIA	Ammonia	Ethanol	Hexane	Acetaldehyde	Ethyl nitrite
		Carbon monoxide	Butanol	Gasoline		
	Ethane	Butane	Kerosene	Trimethylamine		
IIB	Toluene	Acetylacetone	Pentane			
	Propane	Vinyl chloride				
	Methane					
IIC	Hydrogen cyanide	Furane	Dimethyl ether			
	Acrylonitrile	Ethyl acrylate	Cyclohexane			
	Coal gas	Ethylene	Isoprene			
	Hydrogen	Acetylene			Carbon dioxide	Ethyl nitrate

Installation Environment

Reliable and robust for outdoor installation

With an aluminum alloy housing, anti-corrosion treatment, and baked finish, these switches are weather-resistant. Silicone rubber has been used in sealing materials for its excellent weather-proofing properties, and all external screws are made of stainless steel.

Corrosion-Resistant

Corrosion-resistance prevents salt damage

The housing uses a corrosion-resistant aluminum alloy, with further anti-rust treatment and a baked acrylic finish to prevent corrosion rust, affording improved workability during maintenance and checks.

LX7000 series: Available for all models having a 1LX, 2LX or 5LX head.

VCX-7000 series: Available for all models.

Results of 300 hours of salt spray testing

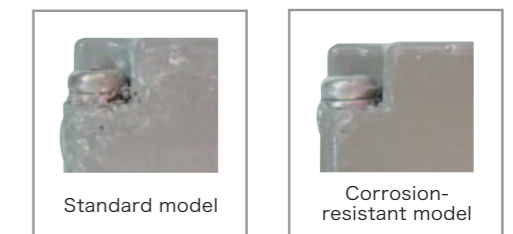

Reliable Switching of Very Low Loads

Switches with gold contacts are available to prevent the corrosion of contacts by atmospheric gases and other elements.

Easily-Removable Cover

When the housing and cover were redesigned to make an explosion-proof container with increased safety, the cover was made so that it can be mounted and removed easily, without pinching wires between the cover and housing during wiring or inspections.

Note: The stipulations for joint surface gap depths and gaps that prevent flame from spreading have been relaxed on increased-safety explosion-proof enclosures, but they can be used for Zone 1 and Zone 2 applications.

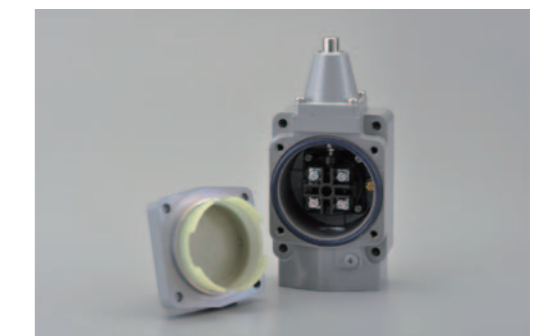



Vertical Explosion-Proof Switches Compliant with IEC Standards

LX7000 Series







- Five different head types are available (roller lever, plunger, roller plunger, fork lever lock, nondirectional movement) according to customer requirements for movement mechanisms. In addition, for the roller lever type, selection can be made from general-purpose limit switch levers according to attachment conditions.
- For the LX7000 series, head orientation can be changed to either front, back, left or right (4-directional).
- For the roller lever type (1LX), the plunger type (2LX) and the roller plunger type (5LX), corrosion-resistant switches are available (see page 3 for details).
- A corrosion-resistant explosion-proof packing connector is also available for use in combination with the increased-safety packing corrosion-resistant type.

Note: Please contact one of our sales representatives for information on corrosion-resistant types.

External standards	Explosion-proof structure	Approval no.
TIIS (Japan)	Ex d e IIC T6	TC18776/TC18778*
NEPSI (China)	Ex d e IIC T6	GYJ101011
KOSHA (South Korea)	Ex d e IIC T6 IP67	09-AV4BO-0327
ATEX (Europe)	II 2G Ex d e IIC T6	KEMA09ATEX0107
IECEX	Ex d e IIC T6 Gb	IECEX KEM 09.0040
NK (shipping)	Ex d e IIC T6	09T608 (type test no.)

*TC18776 for 1LX, TC18778 for non-1LX

Model Numbers

Head type	Actuator	Cable lead-in	Contact material	External standards				
				TIIS·NK	NEPSI	KOSHA	ATEX	
Roller lever	Standard roller lever 	G1/2	Silver alloy	1LX7001-J	1LX7001-P	1LX7001-S	1LX7001	
			Gold-plated	1LX7001-JK	1LX7001-PK	1LX7001-SK	1LX7001-K	
		Increased-safety packing	Silver alloy	1LX7001-R				
			Gold-plated	1LX7001-RK				
		M20	Silver alloy		1LX7001-Q	1LX7001-V	1LX7001-C	
			Gold-plated		1LX7001-QK	1LX7001-VK	1LX7001-CK	
	No lever	G1/2	Silver alloy	1LX7002-J	1LX7002-P	1LX7002-S	1LX7002	
			Gold-plated	1LX7002-JK	1LX7002-PK	1LX7002-SK	1LX7002-K	
		Increased-safety packing	Silver alloy	1LX7002-R				
			Gold-plated	1LX7002-RK				
		M20	Silver alloy		1LX7002-Q	1LX7002-V	1LX7002-C	
			Gold-plated		1LX7002-QK	1LX7002-VK	1LX7002-CK	
Adjustable roller lever 	G1/2	Silver alloy	1LX7003-J	1LX7003-P	1LX7003-S	1LX7003		
		Gold-plated	1LX7003-JK	1LX7003-PK	1LX7003-SK	1LX7003-K		
	Increased-safety packing	Silver alloy	1LX7003-R					
		Gold-plated	1LX7003-RK					
	M20	Silver alloy		1LX7003-Q	1LX7003-V	1LX7003-C		
		Gold-plated		1LX7003-QK	1LX7003-VK	1LX7003-CK		
Plunger	Plunger 	G1/2	Silver alloy	2LX7001-J	2LX7001-P	2LX7001-S	2LX7001	
			Gold-plated	2LX7001-JK	2LX7001-PK	2LX7001-SK	2LX7001-K	
		Increased-safety packing	Silver alloy	2LX7001-R				
			Gold-plated	2LX7001-RK				
		M20	Silver alloy		2LX7001-Q	2LX7001-V	2LX7001-C	
			Gold-plated		2LX7001-QK	2LX7001-VK	2LX7001-CK	
	Roller plunger 	G1/2	Silver alloy	5LX7001-J	5LX7001-P	5LX7001-S	5LX7001	
			Gold-plated	5LX7001-JK	5LX7001-PK	5LX7001-SK	5LX7001-K	
		Increased-safety packing	Silver alloy	5LX7001-R				
			Gold-plated	5LX7001-RK				
		M20	Silver alloy		5LX7001-Q	5LX7001-V	5LX7001-C	
			Gold-plated		5LX7001-QK	5LX7001-VK	5LX7001-CK	
Fork lever lock 	G1/2	Silver alloy	6LX7001-J	6LX7001-P	6LX7001-S	6LX7001		
		Gold-plated	6LX7001-JK	6LX7001-PK	6LX7001-SK	6LX7001-K		
	Increased-safety packing	Silver alloy	6LX7001-R					
		Gold-plated	6LX7001-RK					
	M20	Silver alloy		6LX7001-Q	6LX7001-V	6LX7001-C		
		Gold-plated		6LX7001-QK	6LX7001-VK	6LX7001-CK		
Nondirectional movement 	G1/2	Silver alloy	8LX7001-J	8LX7001-P	8LX7001-S	8LX7001		
		Gold-plated	8LX7001-JK	8LX7001-PK	8LX7001-SK	8LX7001-K		
	Increased-safety packing	Silver alloy	8LX7001-R					
		Gold-plated	8LX7001-RK					
	M20	Silver alloy		8LX7001-Q	8LX7001-V	8LX7001-C		
		Gold-plated		8LX7001-QK	8LX7001-VK	8LX7001-CK		

Notes:

- Please contact one of our sales representatives for information on model numbers with IECEx certification.

LX7000 Series Specifications

Item	Head type				
	Roller lever 1LX7000-□□	Plunger 2LX7001-□□	Roller plunger 5LX7001-□□	Fork lever lock 6LX7001-□□	Nondirectional movement 8LX7001-□□
Structure	Contact form				
	2-circuit double break (2CKT-DB×1)				
	Terminal type				
	M4 pan head screw with square washer				
	Contact material				
Silver/gold-plated rivet					
Explosion-proof structure					
Internal switch: d (explosion-proof), housing: e (increased-safety explosion-proof)					
Protective structure					
IP67 (IEC 60529, JIS C 0920)					
Electrical performance	Electrical rating				
	Silver: 5A at 250 Vac, 0.8A at 125 Vdc, 0.4 A at 250 Vdc Gold-plated: 0.1A at 125 Vac, 0.1 A at 30 Vdc				
	Dielectric strength				
	Between continuous terminals: 600 Vac, 50/60 Hz for 1 minute Between each terminal and non-live metal part: 2000 Vac, 50/60 Hz for 1 minute Between each terminal and ground: 2000 Vac, 50/60 Hz for 1 minute				
	Insulation resistance				
	Min. 100 MΩ (by 500 Vdc megger)				
Mechanical performance	Initial contact resistance				
	Silver: max. 50 MΩ (6-8 Vdc, thermal current 1 A, measured by voltage drop method) Gold-plated: max. 100 MΩ (6-8 Vdc, thermal current 0.1 A, measured by voltage drop method)				
	Recommended min. contact operating voltage/current				
Silver: 10 mA at 24 V, 20 mA at 12 V Gold-plated: 10 mA at 5 V					
Life	Actuator strength				
	Withstands loads 5 times O.F. (operating direction for 1 minute)				
	Terminal strength				
	Withstands tightening torque of 1.5 N-m for 1 minute				
	Impact resistance				
200 m/s ² , contacts open for 1 ms max. in free position and total travel position*1					
Mechanical performance	Vibration resistance				
	1.5 mm peak-to-peak amplitude, frequency 10 to 55 Hz, 2 h continuously, contacts open for 1 ms max. in free position and total travel position				
	Allowable operating speed				
At min. speed, unstable state of contacts lasts for 0.1 s max. At max. speed actuator is not damaged.					
Operating frequency	Max. 120 operations/minute		30 operations/minute	120 operations/minute	
	Mechanical		Min. 4 million operations (with overtravel at 70 to 100% of rated value)	Min. 2 million operations	Min. 4 million operations
Electrical	Silver: min. 200,000 operations, 5 A at 250 Vac, 0.8 A at 125 Vdc, 0.4 A at 250 Vdc (Min. 500,000 operations, 1 A at 250 Vac, 0.2 A at 125 Vdc, 0.1 A at 250 Vdc) Gold-plated: min. 2 million operations, 0.1 A at 125 Vac, 0.1 A at 30 Vdc				
	Operating temperature				
-10 to +60°C (no freezing allowed)					
Environment	Operating humidity				
	45-85%RH				
	Storage temperature				
	-10 to +60°C				
	Storage humidity				
	Max. 98% RH (with conduit section plug inserted)				
Group and temperature class					
IIC T6					
Hazardous area classification					
Zone 1 and Zone 2 hazardous areas					
Recommended tightening torque	Body				
	5-6 N-m (M5 hexagon socket head bolt)				
	Cover				
	5-6 N-m (M5 hexagon socket head bolt with spring washer)				
	Head				
	1.3-1.7 N-m (M4 pan head screw head with spring washer)				
	Terminals				
1.3-1.7 N-m (M4 pan head screw with square washer)					
Lever					
4-5.2 N-m (M5 hexagon socket head bolt)					
Internal ground					
1.3-1.7 N-m (M4 binding head machine screw with spring washer)					
External ground					
1.3-1.7 N-m (M4 binding head machine screw with spring washer)					
Applicable cable size	Terminals	Stranded cable	Nominal cross-sectional area 0.5mm ² to 1.5mm ² (AWG20 to AWG16)		
		Single cable	Nominal cross-sectional area 0.5mm ² to 1.5mm ² (AWG20 to AWG16)		
	Internal ground		Uses M4 crimp-type terminal with insulating coating		
	External ground		Uses M4 crimp-type terminal Cables with a nominal cross-sectional area of up to 4mm ² can be connected		

*1: Not in free position for 8LX
*2: When dock angle is 30° for 5LX.

External Dimensions

Standard roller lever type 1LX7001-□□

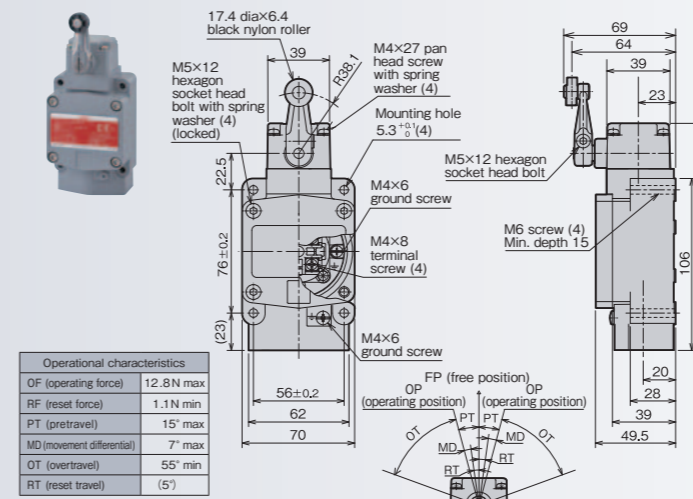

Adjustable roller lever type 1LX7003-□□

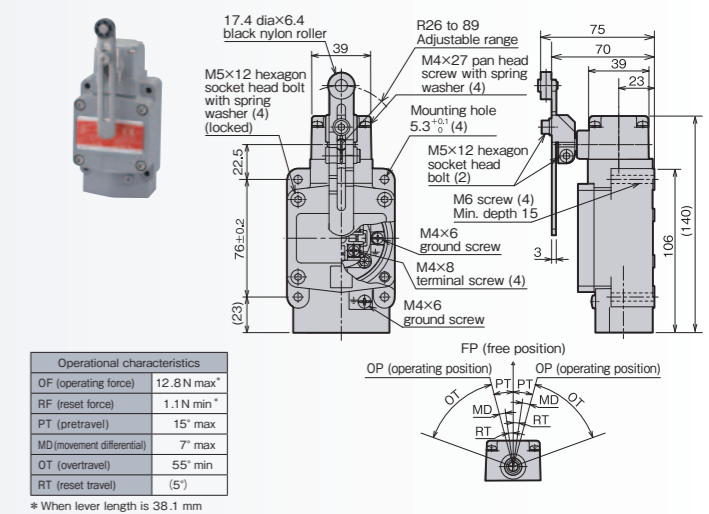

Plunger type 2LX7001-□□

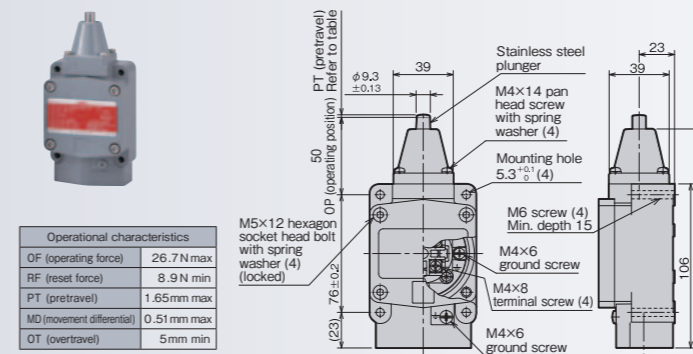

Roller plunger type 5LX7001-□□

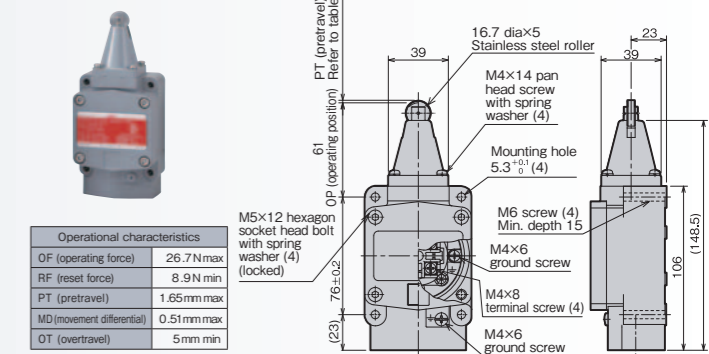

Fork lever lock type 6LX7001-□□

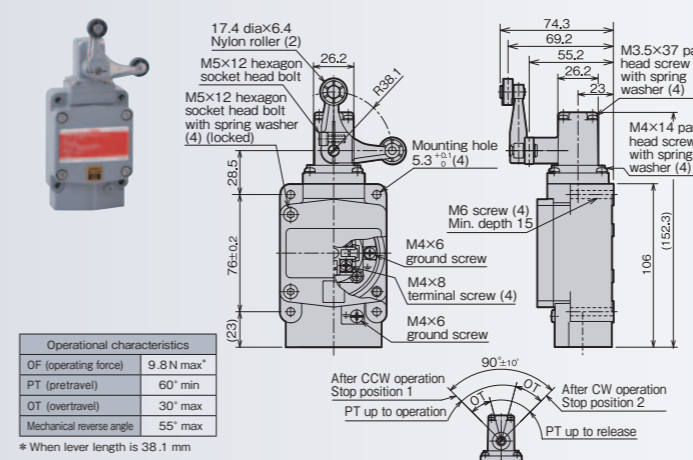

Nondirectional movement type 8LX7001-□□

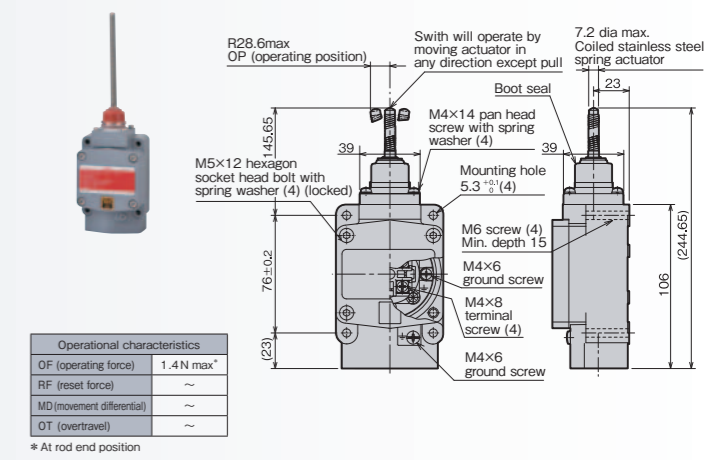

Circuit diagram

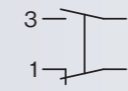

Detailed terminal diagram

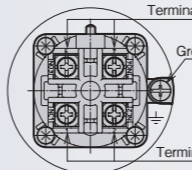

Terminal connections

Terminal no.	Type
1	N.C.
2	N.C.
3	N.O.
4	N.O.

Conduit section details

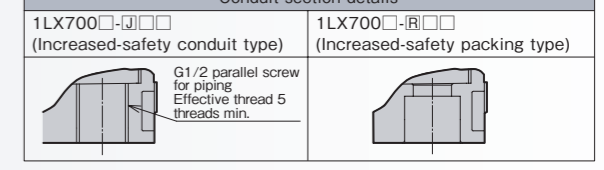

※ Tolerance for dimensions is ± 0.8 unless otherwise stated.



2-Point Detection Explosion-proof Switches Compliant with IEC Standards





VCX-7000 Series

- The center-neutral switch has different internal switches that move in accordance with the direction of the actuator movement. The simultaneous operation type switch has 2 internal switches that move simultaneously, and do not depend on the direction of the actuator movement.
- Actuators can be selected from general-purpose limit switch levers according to attachment conditions.
- The head orientation of the center-neutral switch can be switched to front or back (2-directional) and the head orientation of the simultaneous operation type can be switched to front, back, left or right (4-directional).
- For the VCX-7000 series, the corrosion-resistant type is available for all model numbers (see page 3 on corrosion resistance for more details).
- A corrosion-resistant explosion-proof packing connector is also available for use in combination with the increased-safety packing corrosion-resistant type.

Note: Please contact one of our sales representatives for detailed specifications on the corrosion-resistant type.

External standards	Explosion-proof structure	Approval no.
TIIS (Japan)	Ex d e IIC T6	TC18291
NEPSI (China)	Ex d e IIC T6	GYJ101010
KOSHA (South Korea)	Ex d e IIC T6 IP67	09-AV4BO-0326
ATEX (Europe)	II 2G Ex d e IIC T6	KEMA08ATEX0080
IECEX	Ex d e IIC T6	IECEX KEM 08.0032
NK (shipping)	Ex d e IIC T6	08T614 (type test no.)

Model Numbers

Head type	Actuator	Cable lead-in	Contact material	External standards			
				TIIS·NK	NEPSI	KOSHA	ATEX
Center-neutral type	Standard roller lever 	G3/4	Silver alloy	VCX-7001-J	VCX-7001-P	VCX-7001-S	VCX-7001
			Gold-plated	VCX-7001-JK	VCX-7001-PK	VCX-7001-SK	VCX-7001-K
		Increased-safety packing	Silver alloy	VCX-7001-R			
			Gold-plated	VCX-7001-RK			
		M25	Silver alloy		VCX-7001-Q	VCX-7001-V	VCX-7001-C
			Gold-plated		VCX-7001-QK	VCX-7001-VK	VCX-7001-CK
	No lever	G3/4	Silver alloy	VCX-7002-J	VCX-7002-P	VCX-7002-S	VCX-7002
			Gold-plated	VCX-7002-JK	VCX-7002-PK	VCX-7002-SK	VCX-7002-K
		Increased-safety packing	Silver alloy	VCX-7002-R			
			Gold-plated	VCX-7002-RK			
		M25	Silver alloy		VCX-7002-Q	VCX-7002-V	VCX-7002-C
			Gold-plated		VCX-7002-QK	VCX-7002-VK	VCX-7002-CK
Adjustable roller lever 	G3/4	Silver alloy	VCX-7003-J	VCX-7003-P	VCX-7003-S	VCX-7003	
		Gold-plated	VCX-7003-JK	VCX-7003-PK	VCX-7003-SK	VCX-7003-K	
	Increased-safety packing	Silver alloy	VCX-7003-R				
		Gold-plated	VCX-7003-RK				
	M25	Silver alloy		VCX-7003-Q	VCX-7003-V	VCX-7003-C	
		Gold-plated		VCX-7003-QK	VCX-7003-VK	VCX-7003-CK	
Simultaneous operation type	Standard roller lever 	G3/4	Silver alloy	VCX-7101-J	VCX-7101-P	VCX-7101-S	VCX-7101
			Gold-plated	VCX-7101-JK	VCX-7101-PK	VCX-7101-SK	VCX-7101-K
		Increased-safety packing	Silver alloy	VCX-7101-R			
			Gold-plated	VCX-7101-RK			
		M25	Silver alloy		VCX-7101-Q	VCX-7101-V	VCX-7101-C
			Gold-plated		VCX-7101-QK	VCX-7101-VK	VCX-7101-CK
	No lever	G3/4	Silver alloy	VCX-7102-J	VCX-7102-P	VCX-7102-S	VCX-7102
			Gold-plated	VCX-7102-JK	VCX-7102-PK	VCX-7102-SK	VCX-7102-K
		Increased-safety packing	Silver alloy	VCX-7102-R			
			Gold-plated	VCX-7102-RK			
		M25	Silver alloy		VCX-7102-Q	VCX-7102-V	VCX-7102-C
			Gold-plated		VCX-7102-QK	VCX-7102-VK	VCX-7102-CK
Adjustable roller lever 	G3/4	Silver alloy	VCX-7103-J	VCX-7103-P	VCX-7103-S	VCX-7103	
		Gold-plated	VCX-7103-JK	VCX-7103-PK	VCX-7103-SK	VCX-7103-K	
	Increased-safety packing	Silver alloy	VCX-7103-R				
		Gold-plated	VCX-7103-RK				
	M25	Silver alloy		VCX-7103-Q	VCX-7103-V	VCX-7103-C	
		Gold-plated		VCX-7103-QK	VCX-7103-VK	VCX-7103-CK	

Notes:

- Please contact one of our sales representatives for information on model numbers with IECEx certification.

VCX-7000 Series Specifications

Item		Specifications	
Structure	Contact form	Single-pole double-throw (SPDT)×2	
	Terminal type	M3.5 pan head screw with square washer	
	Contact material	Silver: rivet. Gold alloy: cross-point	
	Explosion-proof structure	Internal switch: d (explosion-proof), housing: e (increased-safety explosion-proof)	
	Protective structure	IP67 (IEC 60529, JIS C 0920)	
Electrical performance	Electrical rating	Silver: 5A at 250 Vac, 0.4A at 125 Vdc, 0.2 A at 250 Vdc Gold alloy: 0.1 A at 125 Vac, 0.1 A at 30 Vdc	
	Dielectric strength	Between continuous terminals: 600 Vac, 50/60 Hz for 1 minute Between non-continuous terminals: 2,000 Vac, 50/60 Hz for 1 minute Between each terminal and non-live metal part: 2000 Vac, 50/60 Hz for 1 minute Between each terminal and ground: 2000 Vac, 50/60 Hz for 1 minute	
	Insulation resistance	Min. 100 MΩ (by 500 Vdc megger)	
	Initial contact resistance	Silver: max. 50 MΩ (6-8 Vdc, thermal current 1 A, measured by voltage drop method) Gold alloy: max. 100 MΩ (6-8 Vdc, thermal current 0.1 A, measured by voltage drop method)	
	Recommended min. contact operating voltage/current	Silver: 10 mA at 24 V, 20 mA at 12 V Gold alloy: 10 mA at 5V	
	Mechanical performance	Actuator strength	Withstands loads 5 times O.F. (operating direction for 1 minute)
Terminal strength		Withstands tightening torque of 0.6N-m for 1 minute	
Impact resistance		200 m/s ² , contacts open for 1 ms max. in free position	
Vibration resistance		1.5 mm peak-to-peak amplitude, frequency 10 to 55 Hz, 2 h continuously, contacts open for 1 ms max. in free position and total travel position	
Allowable operating speed		0.3 mm/s to 0.5 m/s At min. speed, unstable state of contacts lasts for 0.1 s max. At max. speed actuator is not damaged.	
Operating frequency		Max. 120 operations/minute	
Life	Mechanical	Min. 2 million operations (with overtravel at 70 to 100% of rated value)	
	Electrical	Silver: min. 30,000 operations, 5 A at 250 Vac, 0.4 A at 125 Vdc, 0.2 A at 250 Vdc (Min. 100,000 operations, 3 A at 250 Vac, 0.4 A at 30 Vdc, 0.2 A at 125 Vdc, 0.1 A at 250 Vdc) Gold alloy: min. 2 million operations, 0.1 A at 125 Vac, 0.1 A at 30 Vdc	
Environment	Operating temperature	-10 to +60°C (no freezing allowed)	
	Operating humidity	45-85%RH	
	Storage temperature	-10 to +60°C	
	Storage humidity	Max. 98% RH (with conduit section plug inserted)	
	Group and temperature class	IIC T6	
	Hazardous area classification	Zone 1 and Zone 2 hazardous areas	
Recommended tightening torque	Body	5-6 N-m (M5 hexagon socket head bolt)	
	Cover	5-6 N-m (M5 hexagon socket head bolt with spring washer)	
	Head	1.3-1.7 N-m (M4 pan head screw head with spring washer)	
	Terminals	0.8-1.2 N-m (M3.5 pan head screw with square washer)	
	Lever	4-5.2 N-m (M5 hexagon socket head bolt)	
	Internal ground	0.4-0.6 N-m (M3 binding head machine screw with toothed washer)	
	External ground	1.3-1.7 N-m (M4 binding head machine screw with spring washer)	
Applicable cable size	Terminals	Stranded cable	Nominal cross-sectional area 0.5mm ² to 1.5mm ² (AWG20 to AWG16)
		Single cable	Nominal cross-sectional area 0.5mm ² to 1.5mm ² (AWG20 to AWG16)
	Internal ground	Uses M3 crimp-type terminal with insulating coating	
	External ground	Uses M4 crimp-type terminal Cables with a nominal cross-sectional area of up to 4mm ² can be connected	

External Dimensions

Standard roller lever type

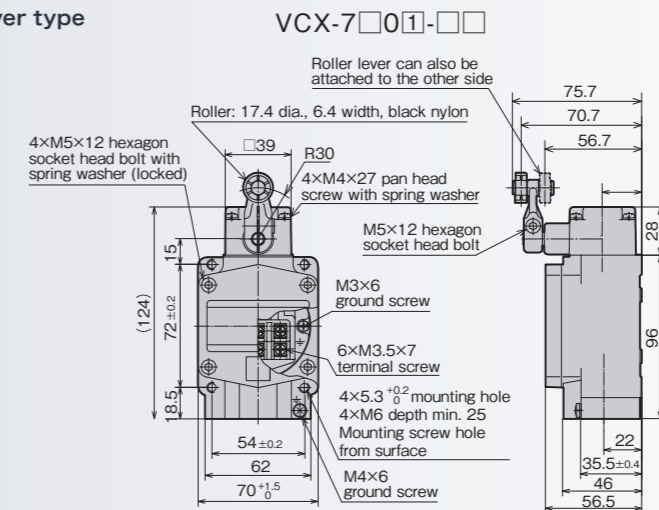

Notes:
*The diagrams above show the shape for brass rollers. For nylon roller shape, see the VCX-7003-□□ diagrams below.

Operational characteristics	Model no.	VCX-700□-□□
OF (operating force)		15.7N max
RF (reset force)		2.2N min
RT (reset travel)		10° max
MD (movement differential)		3° max
OT (overtravel)		35° min
2-switch simultaneous operation		—

Adjustable roller lever type

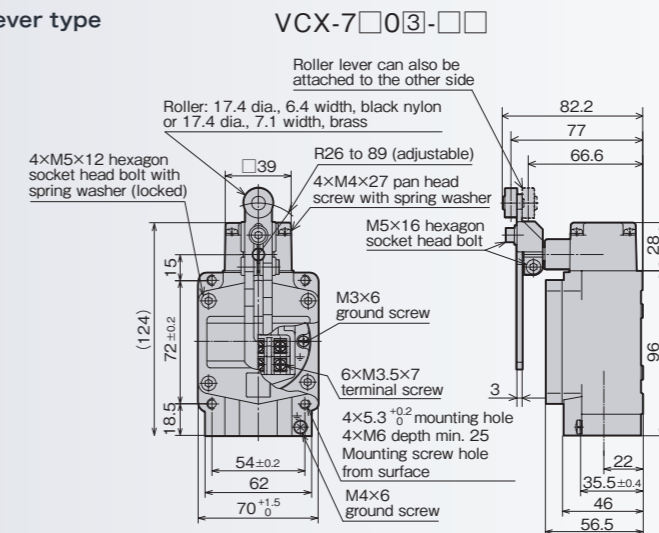

Notes:
*The diagrams above show the shape for nylon rollers. For brass roller shape, see the VCX-7001-□□ diagrams below.
*Tolerance for dimensions is ± 0.8 unless otherwise stated.

Operational characteristics	Model no.	VCX-710□-□□
OF (operating force)		15.7N max*
RF (reset force)		2.2N min*
RT (reset travel)		12° max
MD (movement differential)		3° max
OT (overtravel)		35° min
2-switch simultaneous operation		3° max

*When lever length is 38.1 mm

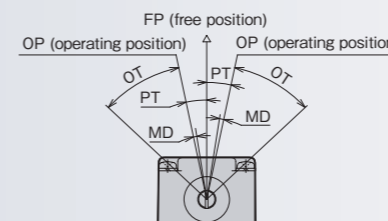

Detailed terminal diagram

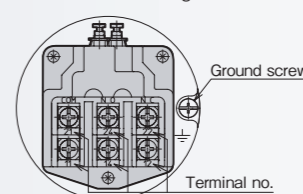

Terminal connections

Switch 1		Switch 2	
Terminal no.	Type	Terminal no.	Type
11	COM	21	COM
12	N.C.	22	N.C.
14	N.O.	24	N.O.

