

**NOTES**

- 1. SWITCH: MICRO SWITCH JISC4505
- 2. SWITCHING SYSTEM

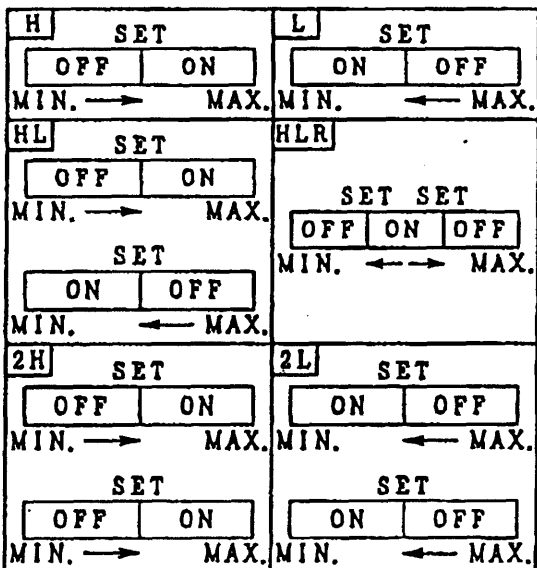

MASS: ABOUT 2.5 kg

**3. ELECTRICAL RATING**

RESISTANCE LOAD	INDUCTIVE LOAD
125V AC 15A	125V AC 15A
250V AC 15A	250V AC 15A
30V DC 2A	30V DC 1A
125V DC 0.5A	125V DC 0.05A

POWER FACTOR: 0.4 MIN.  
TIME CONSTANT: 7ms MAX.

- 4. INDICATION ACCURACY: ± 1.5% F.S.
- 5. SETTING ACCURACY: ± 3% F.S.
- 6. SWITCHING ACCURACY: 1% F.S.

USE		QUANTITY OF SWITCH
GENERAL	CORROSION PROOF	
JM21-1M1	JM21-1M3	1
JM21-2M1	JM21-2M3	2

DWG. No.

					APPD. <i>T. Doso</i>	SCALE $\frac{1}{3}$	TITLE	PRESSURE GAUGE WITH MICRO SWITCH	SHEET NO.
					CHKD. <i>K. Kojima</i>				JM21- 1M1 1M3 2M1 2M3
	<i>Rewrite</i>	<i>Sep. 8 '95</i>	<i>T. SOHMA</i>	<i>T. Doso</i>	DRAWN <i>T. SOHMA</i>	3RD-ANGLE			
REVISION	DATE	DRAWN	APPD.	DATE	OCT. 27 '92				