

FL7M-A Series

Aluminum-chip Immunity DC 2-wire Type Cylindrical Proximity Sensors

FEATURES

Workpieces Reliably Sensed Even if Aluminum or Cast Iron Chips Accumulate on the Sensing Head.

- This DC 2-wire type proximity sensor can be directly connected to programmable controllers and N.C. units. This reduces wiring costs.
- Stable sensing area displayed by setting indicator. (Green/red LED lights red at N.C.)
- Indicator lamp can be confirmed even from the rear side. (pre-leaded model, pre-leaded connector model)
- High seal capabilities. (IP67)
- Aluminum can be sensed at 2mm by the M12, at 2.5mm by the M18 and at 5mm by the M30. (typical values)



click



ORDER GUIDE

Appearance		Sensing distance	Operation mode	Setting indication	Cord characteristics	Catalog listing
Sensor package style	O.D.				Oil resistance	
	M12	2mm	N.O.	○	○	FL7M-2J6AD
			N.C.		○	FL7M-2K6A
	M18	4mm	N.O.	○	○	FL7M-4J6AD
			N.C.		○	FL7M-4K6A
	M30	8mm	N.O.	○	○	FL7M-8J6AD
			N.C.		○	FL7M-8K6A
	M12	2mm	N.O.	○	○	FL7M-2J6AD-CN03
			N.C.		○	FL7M-2K6A-CN03
	M18	4mm	N.O.	○	○	FL7M-4J6AD-CN03
			N.C.		○	FL7M-4K6A-CN03
	M30	8mm	N.O.	○	○	FL7M-8J6AD-CN03
			N.C.		○	FL7M-8K6A-CN03

OPTIONAL ACCESSORIES (sold separately)

Name	Shape	O.D.	Catalog listing
Mounting bracket		For M12	FL-PA112
		For M18	FL-PA118
		For M30	FL-PA130
Protective cover		For M12	FL-PA12
		For M18	FL-PA18
		For M30	FL-PA30

SPECIFICATIONS

Catalog listing		FL7M-2J6AD, FL7M-2K6A	FL7M-4J6AD, FL7M-4K6A	FL7M-8J6AD, FL7M-8K6A
Actuation method		High-frequency oscillation type (shielded)		
Rated sensing distance		2±0.2mm	4±0.4mm	8±0.8mm
Usable sensing distance		0 to 1.4mm	0 to 2.8mm	0 to 5.6mm
Standard target object		12×12mm, 1mm thick iron	30×30mm, 1mm thick iron	54×54mm, 1mm thick iron
Differential travel		20% max. of sensing distance		
Rated supply voltage		12/24Vdc		
Operating voltage range		10 to 30Vdc		
Leakage current		0.55mA max.		
Output operation mode		J: N.O., K: N.C.		
Control output		Switching current: 3 to 100mA, voltage drop: 3V max., output dielectric strength: 30Vdc		
Operating frequency		500Hz	100Hz	60Hz
Temperature characteristics		±10% max. for the range -25 to +70°C	±10% max. for the range of 0 to +50°C, or +25°C max. for the range of -25°C to +70°C when 25°C is taken as standard temperature in sensing distance	
Supply voltage characteristics		±2.5% max. with ±15% voltage fluctuation with rated supply voltage as standard voltage in sensing distance		
Indicator lamps		N.O. type: Operation indication: Lights (red or green) at output Setting indication: Lights (green) in stable sensing area N.C. type: Operation indication: Goes out (red) in sensing area		
Operating temperature range		-25 to +70°C		
Storage temperature range		-25 to +70°C		
Operating humidity range		35 to 95%RH max.		
Insulation resistance		50MΩ min. (at 500Vdc)		
Dielectric strength		500Vac, 50/60Hz for 1 minute		
Vibration resistance		10 to 55Hz, 1.5mm peak-to-peak amplitude, 2 hrs in X, Y and Z directions		
Shock resistance		490m/s ² 10 times in X, Y and Z directions		
Protection		IP67		
Weight (pre-leaded model)		Approx. 60g	Approx. 130g	Approx. 250g
Circuit protection		Surge absorption, load short-circuit protection, reverse connection protection		
Wiring method		Pre-leaded, pre-leaded connector		
Material	Sensor	Case	Ni-plated brass	
		Sensing face	PBT	
	Connector	Housing	Polyester elastomer	
		Holder	Glass-lined polyester resin	
		Contact	Gold-plated brass	

- Installation Instructions No.: CP-UM-3076E

ABOUT SETTING INDICATION

The proximity sensor can detect objects reliably by bringing the proximity sensor close to the target object and setting the sensor at the position where the indicator lamp changes from red to green.

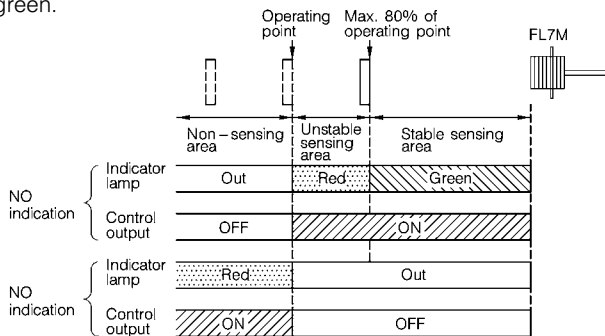

Note: When the target object is made of a different material such as aluminum, copper and stainless steel to the standard target object (iron), the setup point where the indicator lamp changes color is shorter than 80% maximum.

SENSING AREA DIAGRAM (typical example)

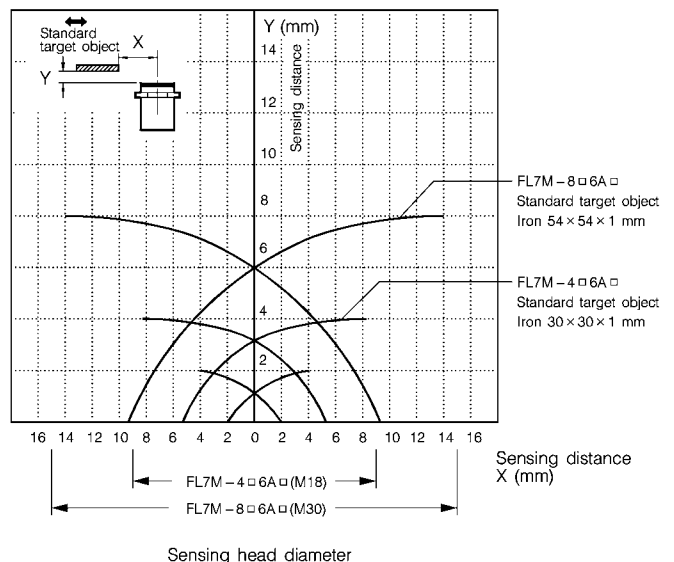

WIRING DIAGRAM

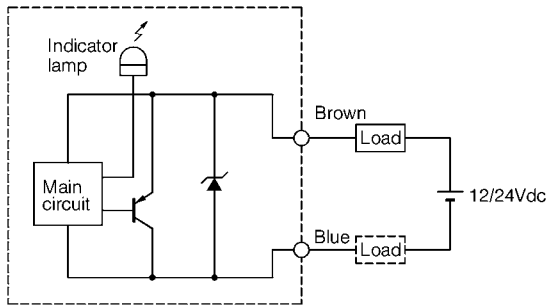

The load can be connected to either of the power supplies.

SENSING DISTANCE ACCORDING TO MATERIAL & SIZE OF OBJECT (typical examples)

FL7M-2 6A

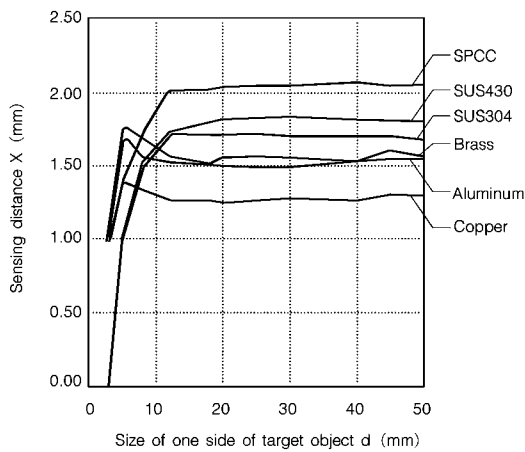

FL7M-4 6A

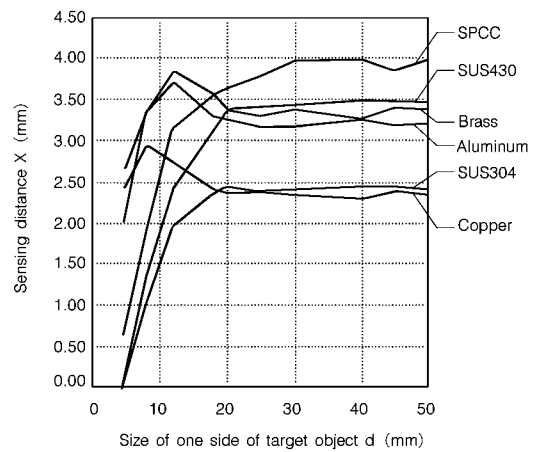

FL7M-8 6A

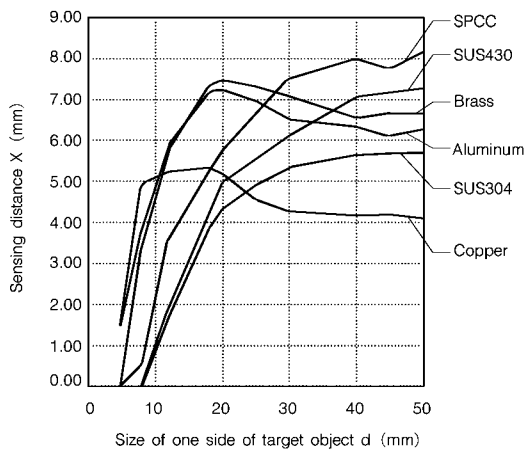

VOLTAGE DROP CHARACTERISTICS (typical example)

● 24Vdc

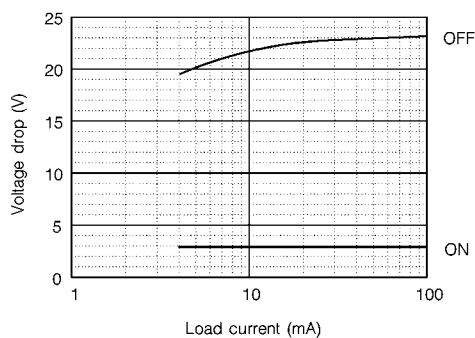

LEAKAGE CURRENT CHARACTERISTICS (typical example)

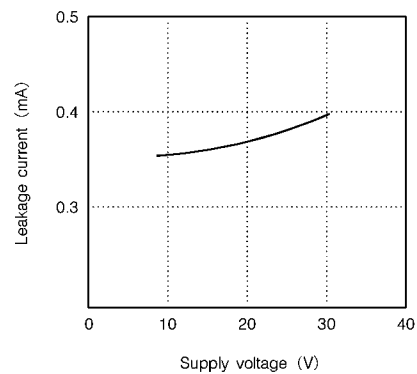

EXTERNAL DIMENSIONS

● Standard (pre-leaded) model

FL7M-2□**6A**□

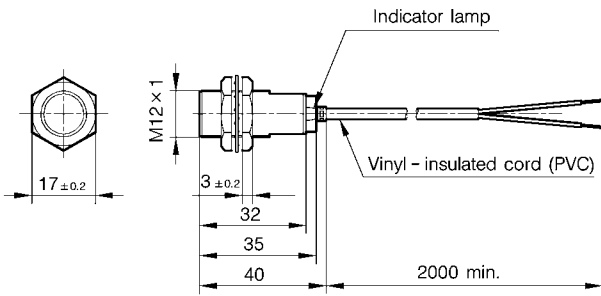

Vinyl-insulated cord (oil-resistant: 0.3mm², 27/0.12dia., 2-core)
4.1mm dia.
Cap color: blue

FL7M-4□**6A**□

(unit: mm)

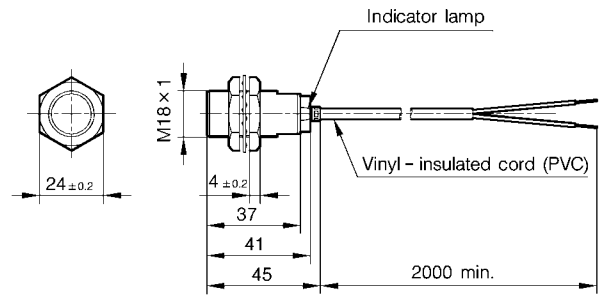

Vinyl-insulated cord (oil-resistant: 0.3mm², 27/0.12dia., 2-core)
4.1mm dia.
Cap color: blue

FL7M-8□**6A**□

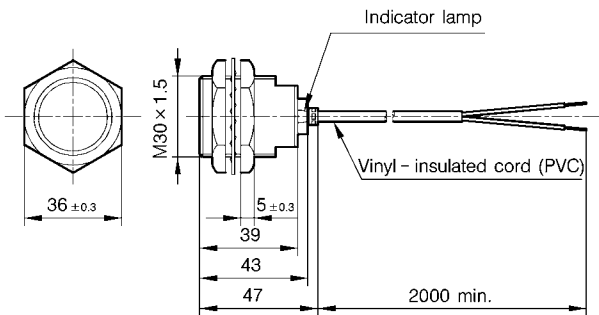

Vinyl-insulated cord (oil-resistant: 0.3mm², 27/0.12dia., 2-core)
4.1mm dia.
Cap color: blue

● Connector model

FL7M-2□**6A**□**CN03**

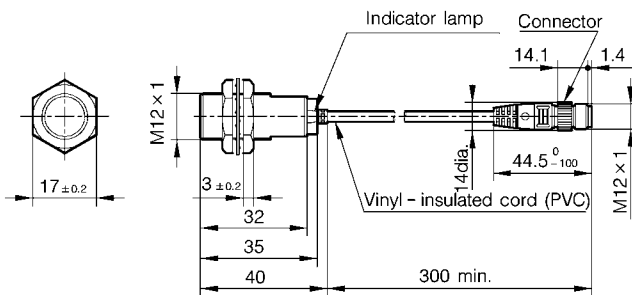

Cap color: blue

FL7M-4□**6A**□**CN03**

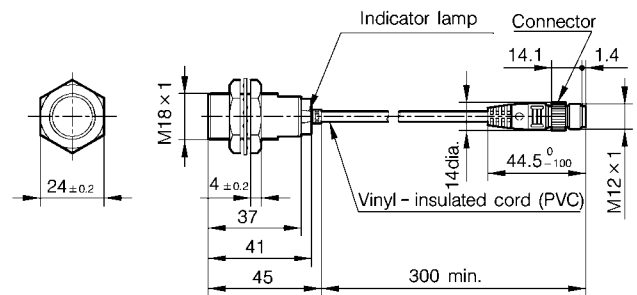

Cap color: blue

FL7M-8□**6A**□**CN03**

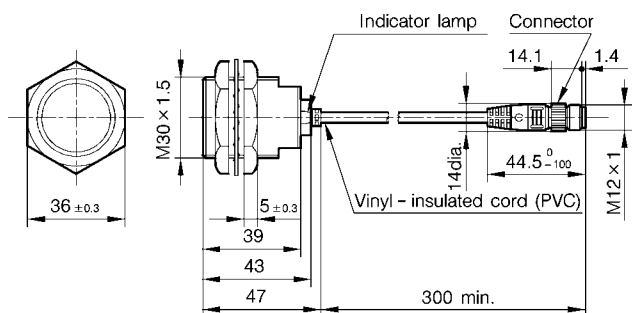

Cap color: blue

MOUNTING BRACKET (sold separately)

Mounting brackets are made of polyacetal resin.
Two screws and two washers are provided for each bracket.

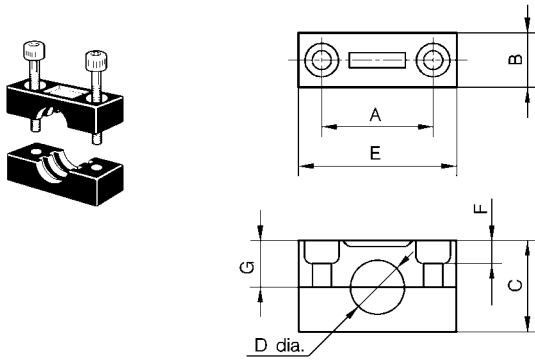

FL-PA118 and **FL-PA130** screw holes are oblong.

Catalog listing	Dimensions (mm)							Screw dimensions	
	A	B	C	D	E	F	G	Diameter	Neck
FL-PA112	25	12	20	12	36	6	9.5	M4	25
FL-PA118	30/32	15	30	18	45	7.5	14.5	M5	35
FL-PA130	40/45	15	50	30	60	10	24.5	M5	55

• Allowable tightening strength of bracket

Catalog listing	Allowable tightening strength (N-m)
FL-PA112	0.98
FL-PA118	1.5
FL-PA130	1.5

PROTECTIVE COVER (sold separately)

Protective covers (material: polyacetal resin) are available for shielded models. Select a model according to the sensor's external dimensions.

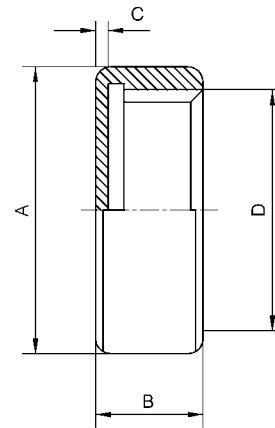

Catalog listing	Dimensions (mm)			
	A	B	C	D
FL-PA12	14dia.	5	$0.5^{+0.2}_{-0.1}$	M12 × 1
FL-PA18	21dia.	6	$0.5^{+0.2}$	M18 × 1
FL-PA30	33dia.	8	$1.5^{+0.2}$	M30 × 1.5

WIRING

- Standard (pre-leaded) model
- Wiring to programmable controller

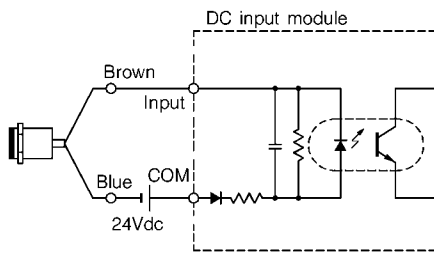

- Wiring to transistor circuit

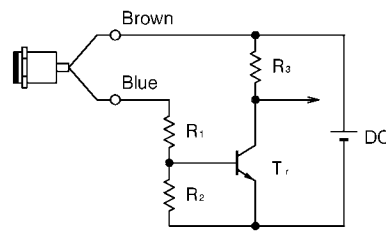

- Wiring to relay load

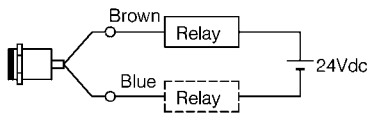

• Connector model, pre-leaded connector model (Lead colors are for when the PA5 is used.)

The connectors have four pins. Contacts are laid out as follows:

Body side

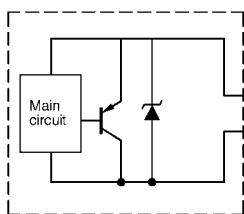

PA5 connector side

N.O. (normally open) type

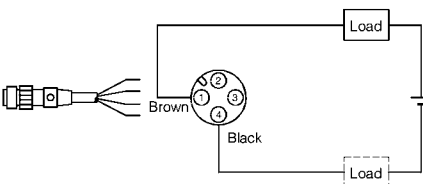

N.C. (normally closed) type

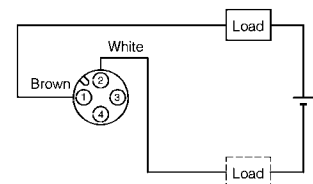

CONNECTOR SPECIFICATIONS Note 1

Item	Specifications
Insulation resistance	100MΩ min. (at 500Vdc)
Dielectric strength	1,500Vac for 1 minute (across contacts, and contacts and connector housing)
Initial contact resistance	40mΩ max. (excluding code conductor-intrinsic when energized by 3A on a male-female contact combination)
Connector withstand stress	0.4 to 4.0N (per contact)
Number of connector insertions	50 times
Connector tightening strength	0.8N-m min. (Note 2)
Cord pullout strength	100N min.
Vibration resistance	10 to 55Hz, 1.5mm peak-to-peak amplitude, 2 hrs in X, Y and Z directions
Shock resistance	300m/s ² , 3 times in X, Y and Z directions
Protection	IP67
Operating temperature range	- 10 to +70°C
Storage temperature range	- 20 to +80°C
Operating humidity range	95%RH max.
Material	Contact: gold-plated brass Contact holder: glass-lined polyester resin Housing: polyester elastomer Coupling: Ni-plated brass O-ring: NBR

Note 1: Specifications assume Yamatake **PA5** Series with **VA** connectors.

Note 2: The recommended torque is 0.4 to 0.6N-m.
If fastened poorly, the IP67 protection is lost, or looseness occurs.
Fasten the connector securely by hand.

CONNECTION CORD WITH CONNECTOR

Be sure to use **PA5** Series cord with **VA** connector when connecting a pre-leaded connector or connector sensors.

• PA5 Series cord with VA connector

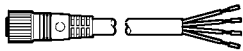
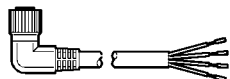
Shape	Power supply	Cord length	Catalog listing	Lead color
	dc	2m	PA5-4ISX2HK	1-brown, 2-white, 3-blue, 4-black
		5m	PA5-4ISX5HK	
		2m	PA5-4ILX2HK	
		5m	PA5-4ILX5HK	

PA5 Series cord with VA connector

Pre-leaded connector model

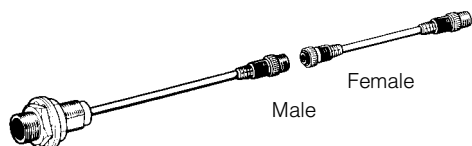

Female
Male

Connector model



Male

Sensor
(male)

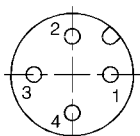

VA Connector
(female)

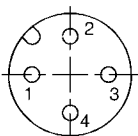

• Fastening the connector

Align the grooves of the connectors and turn the fastening screw of the **VA** connector of the **PA5** cord by hand until it fits tightly with the screw on the sensor side.

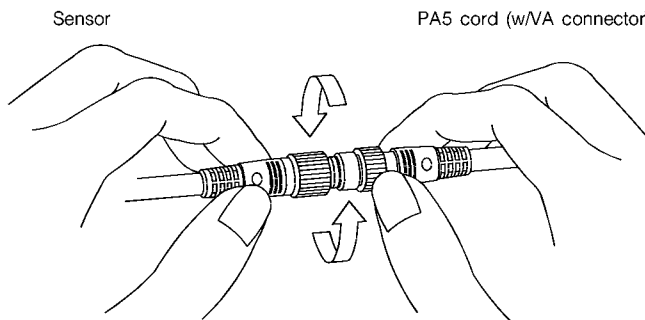

PRECAUTIONS

• Mounting

The allowable tightening torque varies according to the distance from the tip of the sensing head.

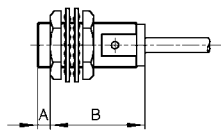

Catalog listing	A dimensions (mm)	Allowable tightening torque (N-m)	
		A	B
FL7M-2□6A□	10	20	30
FL7M-4□6A□	0	—	70
FL7M-8□6A□	0	—	150

Note: The table shows the allowable strength when toothed washers (provided) are used.

• Influence of surrounding metal:

Metal other than the target object surrounding the sensor may influence operating characteristics. Maintain the following space between the sensor and surrounding metal.

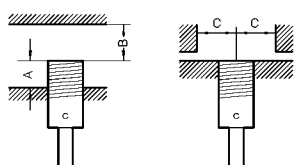

A: Dimension to tip (sensing face) of proximity sensor from mounting surface

B: Dimension to front iron plate from tip (sensing face) of proximity sensor

C: Dimension to front iron plate of proximity sensor when A=0

Shaded areas indicate surrounding metal other than the target object.

Catalog listing	A (mm)	B (mm)	C (mm)
FL7M-2□6A□	0	6	9
FL7M-4□6A□	0	20	13.5
FL7M-8□6A□	0	40	22.5

• Mutual interference prevention

When mounting proximity sensors in parallel or facing each other, mutual interference may cause the sensor to malfunction. Maintain at least the spaces indicated in the figures below.

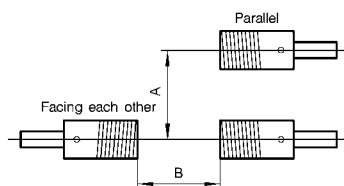

Catalog listing	A (mm)	B (mm)
FL7M-2□6A□	20	30
FL7M-4□6A□	35	50
FL7M-8□6A□	70	100

• Cautions during series or parallel connection

(1) Series connection (AND connection)

When connecting two or more proximity sensors in series, erroneous output (1 to 3ms) may occur without the rated current being supplied to each of the sensors. For this reason, series connection of proximity sensors is not recommended. However, if proximity sensors must be connected in series, a resistor of 10kΩ must be provided in parallel to each of the sensors. However, note that the maximum leakage current in a series connection will be 3.5mA.

Operation lag also will occur, resulting in increased voltage drop, and the operation indicator lamp will not light.

$$\text{Operation lag} = 40\text{ms} \times (\text{number of series connections} - 1)$$

$$\text{Voltage drop} = \text{voltage drop of single sensor} \times \text{number of series connected sensors}$$

(2) Parallel connection (OR connection)

When connecting two or more proximity sensors in parallel, leakage current increases as follows, and may result in faulty load restore.

$$(\text{Leakage current} = \text{Leakage current of single sensor} \times \text{number of series connected sensors})$$

When two or more sensors turn ON in a parallel connection, one (or some) of the sensors may not indicate operation. This is not an abnormality.

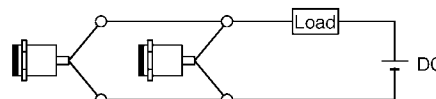

• Relay loads

The voltage drop of the FL7M-A Series is 3.5V. Pay attention to this voltage drop when using a relay load. (With 12Vdc relays, switching is not possible.)

• Operation at power ON

After the power is turned ON, it takes 40ms or less until the proximity sensor is ready for sensing.

When the load and the proximity sensor use different power supplies, be sure to turn the proximity sensor ON before turning the load ON.

• Influence of leakage current

Minimal current flows as leakage current for operating the circuits even when the proximity sensor is OFF.

Take sufficient care when restoring connected loads.

• Minimum cord bending radius (R)

The minimum bending radius (R) of the cord is 3 times cord diameter, take care not to excessively bend the cord beyond this radius. Also, do not excessively bend the cord within 30mm of the cord lead-in port.

ALUMINUM CHIPS AND CAST IRON CHIPS

The sensing signal is not output even if aluminum and cast iron chips are attached and pressing against the sensing face. However, the sensing signal is sometimes output in the following instances:

● FL7M-2□6A□

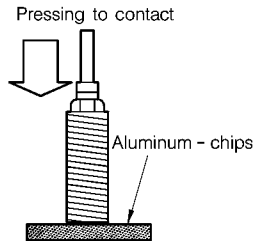

Length of one side alminum chip	FL7M-2J6AD
0.1mm max.	OFF
0.5mm Approx.	OFF
2mm max.	OFF or ON
4mm min.	OFF

● FL7M-4□6A□, FL7M-8□6A□

(1) Chip size (d) × size of sensing face (D)

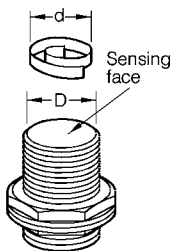

When chips are sensing surface at ratio $d \geq \frac{2}{3}D$

(2) When chips are pressed against sensing face



Catalog listing	Dimensions	D (mm)
FL7M-4J6AD, FL7M-4K6A		16
FL7M-8J6AD, FL7M-8K6A		28



RESTRICIONS ON USE

This product has been designed, developed and manufactured for general-purpose application in machinery and equipment. Accordingly, when used in applications outlined below, special care should be taken to implement a fail-safe and/or redundant design concept as well as a periodic maintenance program.

- Safety devices for plant worker protection
- Start/stop control devices for transportation and material handling machines
- Aeronautical/aerospace machines
- Control devices for nuclear reactors

Never use this product in applications where human safety may be put at risk.

YAMATAKE

Specifications are subject to change without notice.

Yamatake Corporation
Advanced Automation Company

International Business Headquarters

Totate International Building
 2-12-19 Shibuya Shibuya-ku
 Tokyo 150-8316 Japan
 URL: <http://www.yamatake.com>

This has been printed on 100% recycled paper.

(01)

Printed in Japan (SP)

1st Edition: Issued in Apr., 2002

2nd Edition: Issued in Oct., 2003