

Smart Recorder Dot Printing Model SRF106

User's Manual Installation/Operation

Thank you for purchasing the Smart Recorder Dot Printing Model SRF106 . This manual contains information for ensuring correct use of the SRF106. It also provides necessary information for installation, maintenance, and troubleshooting.

This manual should be read by those who design and maintain devices that use the SRF106.

Be sure to keep this manual nearby for handy reference.

Yamatake Corporation

RESTRICTIONS ON USE

This product has been designed, developed and manufactured for general-purpose application in machinery and equipment.

Accordingly, when used in applications outlined below, special care should be taken to implement a fail-safe and/or redundant design concept as well as a periodic maintenance program.

- Safety devices for plant worker protection
- Start/stop control devices for transportation and material handling machines
- Aeronautical/aerospace machines
- Control devices for nuclear reactors

Never use this product in applications where human safety may be put at risk.

REQUEST

Ensure that this User's Manual is handed over to the user before the product is used.

Copying or duplicating this User's Manual in part or in whole is forbidden. The information and specifications in this User's Manual are subject to change without notice.

Considerable effort has been made to ensure that this User's Manual is free from inaccuracies and omissions.

If you should find any inaccuracies or omissions, please contact Yamatake Corporation.

In no event is Yamatake Corporation liable to anyone for any indirect, special or consequential damages as a result of using this product.

© 1994 Yamatake Corporation ALL RIGHTS RESERVED

Smart Recorder SRF106 and Smart Loader Package SLP-F10 are trademarks of Yamatake Corporation.

SAFETY PRECAUTIONS

■ About Icons

Safety precautions are for ensuring safe and correct use of this product, and for preventing injury to the operator and other people or damage to property. You must observe these safety precautions. The safety precautions described in this manual are indicated by various icons.

As the following describes the icons and their meanings, be sure to read and understand the descriptions before reading this manual:



WARNING

Warnings are indicated when mishandling this product might result in death or serious injury to the user.







CAUTION

Cautions are indicated when mishandling this product might result in minor injury to the user, or only physical damage to this product.







■ Examples

	<p>Triangles warn the user of a possible danger that may be caused by wrongful operation or misuse of this product.</p> <p>These icons graphically represent the actual danger. (The example on the left warns the user of the danger of electric shock.)</p>
	<p>White circles with a diagonal bar notify the user that specific actions are prohibited to prevent possible danger.</p> <p>These icons graphically represent the actual prohibited action. (The example on the left notifies the user that disassembly is prohibited.)</p>
	<p>Black filled-in circles instruct the user to carry out a specific obligatory action to prevent possible danger.</p> <p>These icons graphically represent the actual action to be carried out. (The example on the left instructs the user to remove the plug from the outlet.)</p>

WARNING

	Before removing/mounting or wiring the SRF106, be sure to turn the power OFF. Touching electrically charged parts on the SRF106 such as terminals by mistake might cause electric shock.
	Before connecting the SRF106 to the measurement target or external control circuits, make sure that a protective ground terminal is connected to the SRF106. Failure to do so might cause electric shock or fire.
	The black-headed screw on the right of the main unit is for ground protection. Never remove this screw. Doing so might cause electric shock.
	To prevent danger before you replace the clock backup battery, turn the power OFF, and disconnect the SRF106 from its power supply.

CAUTION

	Wire the SRF106 according to predetermined standards. Also wire the SRF106 using designated power leads according to recognized installation methods. Failure to do might cause electric shock, fire or faulty operation.
	Use the SRF106 within the operating ranges recommended in the specifications (temperature, humidity, voltage, vibration, shock, atmosphere, etc.). Failure to do so might cause faulty operation.
	Do not block ventilation holes. Doing so might cause faulty operation.
	Do not disassemble the SRF106, nor touch components inside the SRF106. Doing so might cause electric shock or faulty operation.
	Do not touch internal components during use or immediately after turning the power OFF. Doing so might cause burns.
	Do not touch moving parts during operation. Doing so might cause injury.
	Do not operate the keys with a propelling pencil or sharp-tipped object. Doing so might cause faulty operation.

SAFETY REQUIREMENT



To reduce risk of electrical shock which could cause personal injury, follow all safety notices in this documentation.



This symbol warns the user of a potential shock hazard where hazardous live voltages may be accessible.

- If the equipment is used in a manner not specified by the manufacturer, the protection provided by the equipment must be impaired.
- Do not replace any component (or part) not explicitly specified as replaceable by your supplier.
- All wiring must be in accordance with local norms and carried out by authorized experienced personnel.
- The protective conductor terminal must be connected before any other wiring (and disconnected last).
(Class I:IEC536)

EQUIPMENT RATINGS

Supply voltages	: 100 to 240Vac (allowable voltage: 90 to 250Vac)
Frequency	: 50/60Hz
Power or current ratings	: 30VA maximum
Fuse	: 2A 250V~Time-lag (IEC127)
Sound pressure level	: 80dB(A)maximum (at a position of 1 meter from the equipment)

EQUIPMENT CONDITIONS

Do not operate the instrument in the presence of flammable liquids or vapors. Operation of any electrical instrument in such an environment constitutes a safety hazard.

Temperature	: 0 to 50°C
Humidity	: 30 to 90%RH
Vibration	: Frequency 0 to 100Hz Acceleration 0.98m/s ² maximum
Installation category	: CategoryII (IEC664-1, EN61010-1)
Pollution degree	: Pollution degree 2
Environmental condition	: Permanently connected equipment, Indoor use, Panel mounted equipment

EQUIPMENT INSTALLATION

The recorder must be mounted into a panel to limit operator access to the rear terminals.

Specification of common mode voltage:

The common mode voltages of all I/O except for main supply are less than 30Vr.m.s. 42.4V peak and 60Vdc.

CONFORMED STANDARD

EN61010-1, EN50081-2, EN50082-2

! Handling Precautions

When the carrying handle kit is installed, the recorder does NOT conform to the standard EN61010-1.

CAUTION

Danger of explosion if battery is incorrectly replaced.

Replace only with the same or equivalent type recommended by the manufacturer.

Dispose of used batteries according to the manufacturer's instructions.

Unpacking

■ Check the Contents of the Package

Make sure that the package contains all of the items on the packing list below.

Name	Q'ty	Remarks
Body	1	
Folding chart (50-sections)	1	
Ink ribbon cassette	1	
Fuse	1	
Mounting bracket	1	

■ About Non-use of Transportation Fastening Screws

Transportation fastening screws are not used as the structure of this product is such that the chassis (inner part of the recorder) is fastened to the case by screws.

■ Never Remove the Black-headed Screw on the Main Unit

WARNING



The black-headed screw on the right of the main unit is for ground protection. Never remove this screw. Doing so might cause electric shock.

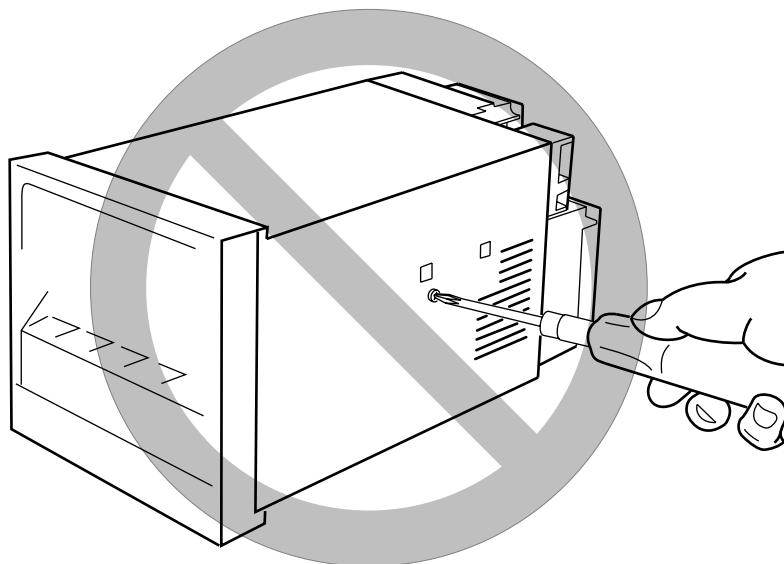

The Role of This Manual

In all, three manuals have been prepared for the SRF106. Read the manual according to your specific requirements. The following lists all the manuals that accompany the SRF106 and gives a brief outline of the manual. If you do not have the required manual, contact Yamatake Corporation or your dealer.

For details on the SRF100 pen printing models (SRF101/102/103), refer to “Pen Printing Model Smart Recorder SRF101/102/103 User’s Manual, Installation/Operation (CP-UM-1667E).”

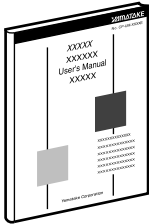

Installation/Operation Manual

Manual No.CP-UM-1666E

This manual.

This manual is required reading for those who use the SRF106, those who design hardware for integrating the SRF106 into operator control panels, those who carry out maintenance, and those who operate instruments in which the SRF106 is integrated.

It describes how to install and wire the SRF106 for integrating into instruments, method of operation, maintenance and inspection, troubleshooting, and hardware specifications.

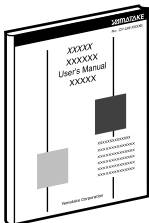

Digitronik CPL Communications Manual SRF101/102/103/106/201/202/203

Manual No.CP-UM-1668E

The SRF101/102/103/106/201/202/203 can communicate with other equipment via the RS-485 or RS-232C interfaces.

This manual is required reading for those who use the CPL communication functions of the SRF101/102/103/106/201/202/203.

It briefly describes CPL communications, how to wire the SRF101/102/103/106/201/202/203, communication procedures, communication data for the SRF101/102/103/106/201/202/203, troubleshooting and communication specifications.

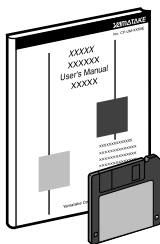

Smart Loader Package SLP-F10/F20

Manual No.CP-UM-5067E

This manual is packaged with the SLP-F10/F20.

Running the SLP-F10/F20 package on a personal computer enables you to set up SRF100/200 parameters on the personal computer. This manual describes operations on the personal computer.

This manual is the common manual of the SLP-F10 and the SLP-F20.

Organization of This User's Manual

This manual is organized as follows:

Chapter 1. INTRODUCTION

This chapter describes SRF106 applications and features, and gives a list of catalog numbers.

Chapter 2. NAMES & FUNCTIONS OF PARTS

This chapter describes the names and functions of parts on the SRF106.

Chapter 3. INSTALLATION & WIRING

This chapter describes precautions, siting conditions and installation method when installing the SRF106 into devices, and how to connect to peripheral equipment.

Chapter 4. PREPARATION & OPERATION

This chapter describes checks to carry out before operating the SRF106 and daily operation procedure.

Chapter 5. BASIC CONFIGURATION

This chapter describes the basic setup details of the SRF106.

Chapter 6. DETAILED CONFIGURATION

This chapter describes all items that can be set using the operation keys.

Chapter 7. SETUP EXAMPLE

This chapter describes how to set up the SRF106 using actual examples.

Chapter 8. MAINTENANCE

This chapter describes inspection items and how to replace maintenance parts to ensure prolonged use of the SRF106.

Chapter 9. TROUBLESHOOTING

This chapter describes points to check when the SRF106 is not working properly and how to remedy trouble that might occur.

Chapter 10. SPECIFICATIONS

This chapter describes the general specifications, performance specifications and external dimensions of the SRF106.

APPENDICES

Contents

SAFETY PRECAUTIONS	
SAFETY REQUIREMENT	
Unpacking	
The Role of This Manual	
Organization of This User's Manual	
Conventions Used in This Manual	

Chapter 1. INTRODUCTION

1-1 Applications and Features	1-1
■ Features	1-1
■ Optional Functions	1-2
1-2 Model Selection Guide	1-3
■ Model Listing	1-3
■ Related Parts Model Listing	1-3

Chapter 2. NAMES & FUNCTIONS OF PARTS

2-1 Main Unit	2-1
■ Overall Schematic and Names of Parts	2-1
■ Terminals on Rear Side	2-2
2-2 Display Setup Unit	2-3
■ Operation Display and Operation Keys	2-3
■ Configuration Unit and Operation Keys	2-4





Chapter 3. INSTALLATION & WIRING

3-1 Installation Site	3-1
■ Siting Conditions	3-1
3-2 Installation	3-2
■ Installation Dimensions	3-2
■ Installation Procedure	3-2
3-3 Wiring Precautions	3-3
■ Description of Symbols on Terminal Layout Label	3-3
■ Noise Countermeasures	3-4
■ Recommended Crimped Terminal	3-4
3-4 Connecting the Power Supply and Ground	3-5
3-5 I/O Signal Leads	3-6
■ Wiring Analog Inputs	3-7
■ Wiring Event Outputs (optional function)	3-7
■ Wiring External Switch Inputs (optional function)	3-8
■ Connecting the RS-485 Interface (optional function)	3-9
■ Connecting the RS-232C Interface (optional function)	3-10

Chapter 4. PREPARATION & OPERATION

4-1	Preparation (loading the chart and ink ribbon cassette)	4-1
■	Loading (replacing) the Chart	4-1
■	Loading (replacing) the Ink Ribbon Cassette	4-4
4-2	Operation	4-6
■	Turning the Power ON	4-6
■	Starting/stopping Recording	4-6
■	Feeding the Chart	4-7
■	Selecting the Display Mode	4-7
■	Recording a Specific Table	4-8
■	Other Displays and Operations	4-9
■	Printout Details	4-10

Chapter 5. BASIC CONFIGURATION

5-1	Introduction	5-1
5-2	Basic Key Operation at Setup, Configuration Lock and Extended Menu	5-2
■	Basic Key Operations at Setup	5-2
■	Canceling the Configuration Lock	5-4
■	Switching the Extended Menu ON/OFF	5-5
5-3	Changing Event Setting Values	5-6
■	Starting Setup	5-6
■	Selecting the Target Channel No.	5-6
■	Selecting the Target Event No.	5-7
■	Enabling Changing of Event Setting Values	5-7
■	Entering the Setting Value Using the ▲/▶ Keys, and Pressing the  key	5-7
5-4	Changing the Chart Feed Speed	5-8
■	Starting Setup	5-8
■	Changing the Chart Feed Speed	5-8
■	Pressing the  key	5-9
■	Chart Feed Speed No. and Chart Feed Speed	5-9
5-5	Changing the Date/Time	5-10
■	Starting Setup	5-10
■	Changing the Date	5-10
■	Pressing the  key	5-11
■	Changing the Time	5-11
■	Pressing the  key	5-11
5-6	Printing Lists	5-12
■	Stopping Recording	5-12
■	Starting Setup	5-12
■	Selecting the List to be Printed	5-13
■	Pressing the  key	5-13
■	Stopping List Printing Midway	5-13

Chapter 6. DETAILED CONFIGURATION

6-1	Introduction	6-1
6-2	Configuration Data and Factory Settings	6-2
	■ Event Setup (individual channels): EVNT	6-2
	■ Chart Feed Speed Setup: SPD	6-2
	■ Date/Time Setup: CLK	6-2
	■ Scale Setup (individual channels): SCL	6-2
	■ System Setup: SYS	6-3
	■ Range Setup: RNG	6-3
6-3	Event Setup	6-4
	■ Event Setup	6-4
	■ Description of Event Setup Items	6-5
6-4	Chart Feed Speed Setup	6-6
	■ Chart Feed Speed Setup	6-6
	■ Description of Chart Feed Speed Setup Items	6-7
6-5	Date/Time Setup	6-8
	■ Date/Time Setup	6-8
6-6	System Setup	6-10
	■ System Setup	6-10
	■ Description of System Setup Items	6-11
6-7	Range Setup	6-12
	■ Range Setup	6-12
	■ Description of Range Setup Items	6-13
6-8	Scale Setup	6-16
	■ Scale Setup	6-16
	■ Description of Scale Setup Items	6-17
	■ Making and Mounting an Analog Scale	6-18
6-9	Range Code Table	6-20
6-10	Character Code Table	6-21
6-11	External Switch Inputs (Optional Functions)	6-22
	■ Default Function Assignments	6-22
	■ List of Functions Settable Using the Smart Loader Package (SLP-F10)	6-22
	■ Detecting External Switch Input	6-22
6-12	Printout Messages	6-23
	■ Printout Message Defaults	6-23
	■ Characters That Can be Set by the Smart Loader Package (SLP-F10)	6-23
6-13	About Digital Printing Priority	6-24
	■ Printing Control during a Print Conflict	6-24
	■ Simultaneous Printing Control	6-24

Chapter 7. SETUP EXAMPLES

7-1	Setup Example 1	7-1
■	Setup Items	7-1
■	Procedure	7-4
■	Actual Setup	7-4
7-2	Setup Example 2	7-10
■	Setup Items	7-10
■	Procedure	7-11
■	Actual Setup	7-11
7-3	Setup Example 3	7-19
■	Setup Items	7-19
■	Procedure	7-20
■	Actual Setup	7-20

Chapter 8. MAINTENANCE

8-1	Periodic Inspection	8-1
■	Faint Recording or Printing	8-1
■	Incorrect Feeding of Chart, Paper Jam	8-1
■	Insufficient Remaining Chart	8-1
■	Alarm Code “AL03” Displayed	8-1
■	Alarm Code Other Than “AL03” Displayed	8-1
8-2	Replacing the Clock Backup Battery	8-3
8-3	Replacing the Fuse	8-6
8-4	Chart Illumination Lamp	8-7
8-5	Measuring the Display Accuracy of Analog Inputs	8-8
■	Equipment Required for Measurement	8-8
■	Measurement Environment	8-8
■	Procedure	8-8
8-6	Adjusting the Dot Position	8-10
■	About Recording Accuracy	8-10
■	About Standard Conditions	8-10
■	Procedure	8-11

Chapter 9. TROUBLESHOOTING

9-1	Alarm Display and Descriptions	9-1
9-2	Remedying Trouble	9-4

Chapter 10. SPECIFICATIONS

10-1 Specifications	10-1
■ General Specifications	10-1
■ Performance Specifications	10-2
10-2 Input Types, Ranges and Display Accuracy	10-6
10-3 External Dimensions	10-8

APPENDICES

■ Appendix Contents	App.-1
■ How to Use the Setup Sheets	App.-1
■ Setup Details	App.-2
■ User Setup Field	App.-3
■ Setup Details	App.-4
■ User Setup Field	App.-5
■ Setup Details	App.-6
■ User Setup Field	App.-7

Conventions Used in This Manual

The following conventions are used in this manual:



Handling Precautions

: Handling Precautions indicate items that the user should pay attention to when handling the SRF106.



Note

: Notes indicate useful information that the user might benefit by knowing.

(1), (2), (3)
[1], [2], [3]

: The numbers with the parenthesis indicate steps in a sequence or indicate corresponding parts in an explanation.

Chapter 1. INTRODUCTION

1 - 1 Applications and Features

This full multi-input, 6 dot printing, high-function recorder accommodates a 100mm wide chart. This recorder offers the dual features of functions and operating ease as a recorder for various equipment and instrumentation. It also supports event output, external switch inputs, chart illumination lamp and communications, as optional functions.

■ Features

- Any combination of inputs and recording scales can be freely set.
DC voltage, thermocouple, resistance temperature detector (RTD)
- Three recording formats are provided and can be freely selected:
 - Trend recording
 - Trend + tabulation recording
 - Trend + schedule demand recording
- Three measurement methods are provided and can be selected to each channel:
 - Measurement value (PV value)
 - Deviation value between channels
 - Deviation value from fixed value
- Universal power supply allows use anywhere:
100 to 240Vac, 50/60Hz
- Wide range of printing functions:
 - Measurement value (PV value)
 - Channel No.
 - Tag (6 characters per channel)
 - Engineering unit (6 characters per channel)
 - Recording scale (2 types, upper/lower limit values)
 - Chart feed speed
 - Event status (details, time of occurrence/restoration)
 - Time marker
 - Date
 - Time (h:min)
- Printing at the following start conditions is possible:
 - Date
 - Time (h:min)
 - Recording format
 - Chart feed speed
 - Recorder ID No.
- Demand printing also is possible.
Printing is started by the  key or external switch input (option), and time (h:min) and measurement values (PV value) are printed.
- When trend + schedule demand recording is selected as the recording format, the measurement value (PV value) of up to four preset times can automatically be printed.
- Messages (six characters each for up to four messages) can be printed together with time (h:min) data by the remote switch.
- Event occurrence and reset are printed together with time (h:min) data.

- Printing of “Date/Time (h:min)”, “Scale” and “Event” can be disabled in the settings.
- Two list printing modes are available for printing setup data: print specified list and print all lists.
- Upscale, downscale or OFF can be set as the thermocouple burnout setting for each input channel.
- Setup data is protected in EEPROM when the power is OFF.
- The recorder is constructed so that the print section is tilted forwards so that movements in the latest trends can be easily seen.

■ Optional Functions

The following optional functions are available:

- Relay outputs (6 outputs; SPDT relay output)
- External switch inputs (remote switch input)
(4; Recording ON/OFF, Demand printing, Chart feed, Print messages No.1 to No.4, Chart feed speed/Scale selection)
- Chart illumination lamp (cold cathode fluorescent light)
- Communications (RS-485, RS-232C)

1 - 2 Model Selection Guide

■ Model Listing

Basic model No.	Power	Input	Option 1	Option 2	Option 3	Addition 1	Addition 2	Specifications
SRF106								100mm 6-dot recorder
	A							100 to 240Vac
		S						Full multi-input (standard specification)
			0					None
			1					Event relay (6)
			2					Event relay (6) + external switch inputs (4)
				0				None
				1				RS-485
				2				RS-232C
					0			None
					1			Chart illumination lamp provided
						0		None
						D		Inspection certificate provided
						T		Tropical treatment
						B		Tropical treatment + Inspection certificate provided
							0	None

■ Related Parts Model Listing

● Consumables

Name	Model No.	Application Range (example)	Remarks
Folding chart (40-sections)	81409977-004	0 to 160, 0 to 200, 0 to 400 0 to 800	10 packets, 16m
Folding chart (50-sections)	81406088-001	0 to 100%	10 packets, 16m
Folding chart (60-sections)	81409977-002	0 to 30, 0 to 120, 0 to 300, 0 to 600	10 packets, 16m
Folding chart (70-sections)	81409977-003	0 to 14, 0 to 700, 0 to 1400 -20 to +50	10 packets, 16m
Folding chart (75-sections)	81409977-005	0 to 150, 100 to 250, 0 to 750	10 packets, 16m
Folding chart (Recycled paper) (50-sections)	81409977-001	0 to 100%	10 packets, 16m
Clean paper chart (50-sections)	81407115-001	For clean room, 0 to 100%	10 packets, 12m
Ink ribbon cassette	81406107-001	—	1 cassette

● Optional Parts

Name	Model No.	Remarks
Add-on optional unit EV (6)	81446645-001	EV: Event relay
Add-on optional unit EV (6) + RSW (4)	81446645-002	RSW: External switch input
Add-on optional unit EV (6) + RSW (4) + RS-232C	81446645-003	
Add-on optional unit EV (6) + RSW (4) + RS-485	81446645-004	
Add-on optional unit RS-232C	81446645-007	
Carrying handle kit	81446424-001	Power cable supplied
250Ω resistor (accuracy ±0.02%)	81401325	1 p'ce
250Ω resistor (accuracy ±0.05%)	81446642-001	2 p'ces
Cross connection cable for RS-232S interface	CBL232FNZ02	1 p'ce 2m

● Maintenance Parts

Name	Model No.	Remarks
Standard tag plate	81406080-001	10 p'ces
DIN type tag plate	81406080-002	10 p'ces
Fuse	81446289-001	10 p'ces
Mounting bracket	81446291-001	1 set (2 brackets)
Replacement door	81446340-001	W/ pin and spring
Chart cassette	81446341-001	Unit ass'y component
Chart holding spring	81446342-001	Stainless steel component
Chart guide	81446343-001	Plastic formed component (transparent)
Option terminal cover	81446427-002	
Analog input terminal cover	81446428-002	
Power terminal cover	81446429-001	
M3.5 free terminal screw	81446441-002	10 p'ces
Power cable	81446475-001	

● Smart Loader Package SLP

Name	Model No.	Remarks
Smart Loader Package	SLP-F10 * * *	

Chapter 2. NAMES & FUNCTIONS OF PARTS

2 - 1 Main Unit

■ Overall Schematic and Names of Parts

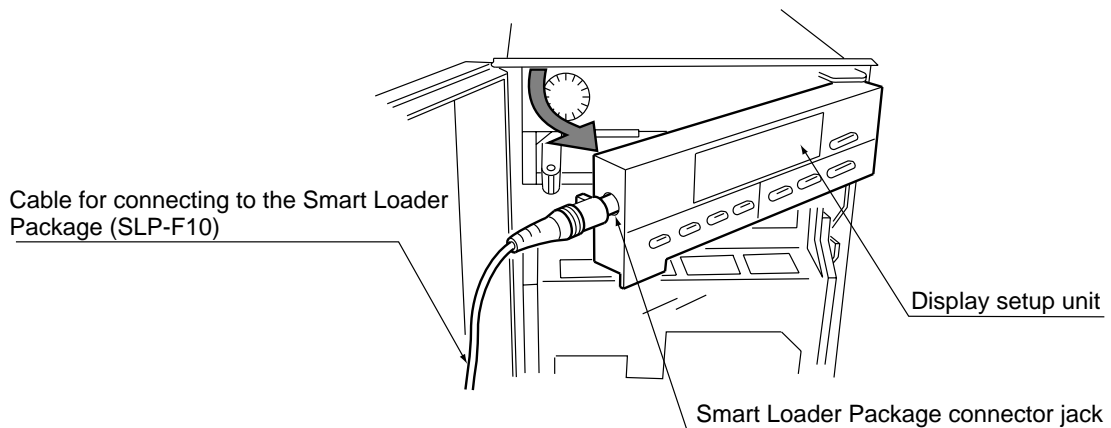
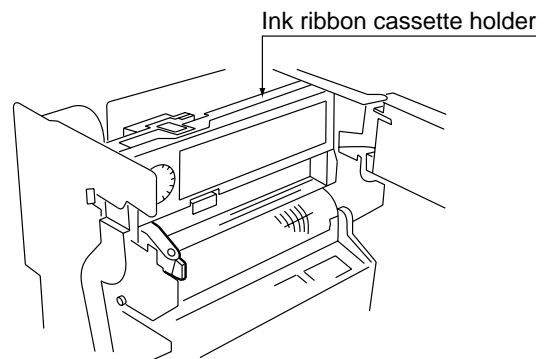
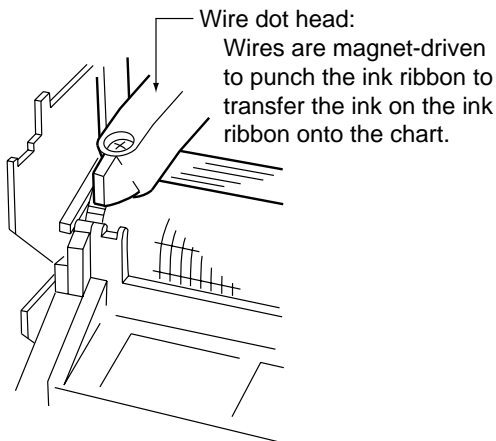
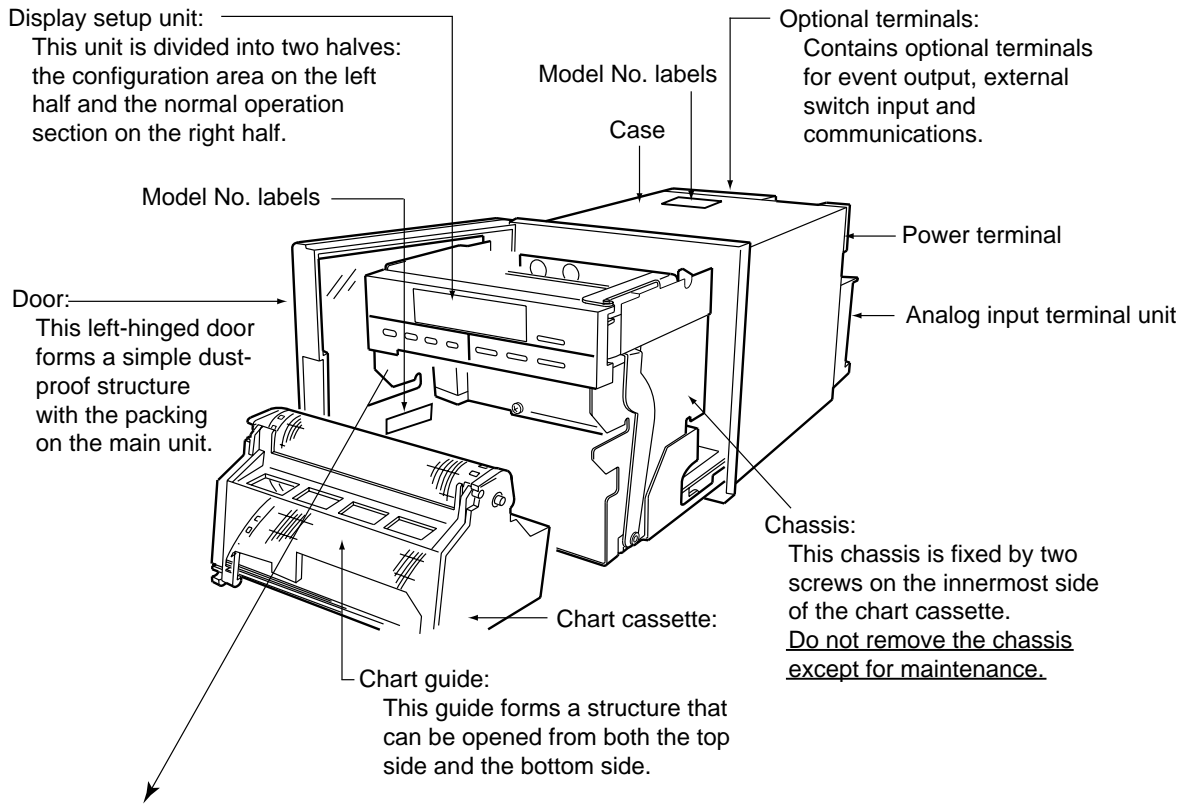

■ Terminals on Rear Side

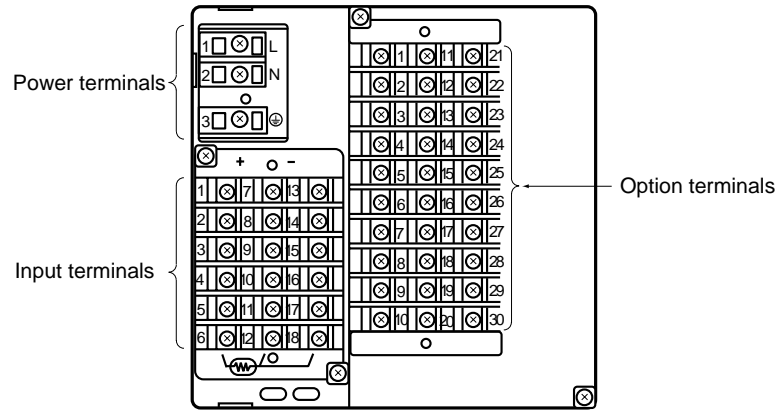

For details on signals connected to terminals, see Chapter 3. INSTALLATION & WIRING.

2 - 2 Display Setup Unit

■ Operation Display and Operation Keys

The following describes the operation panel on the display setup unit.

● Operation keys

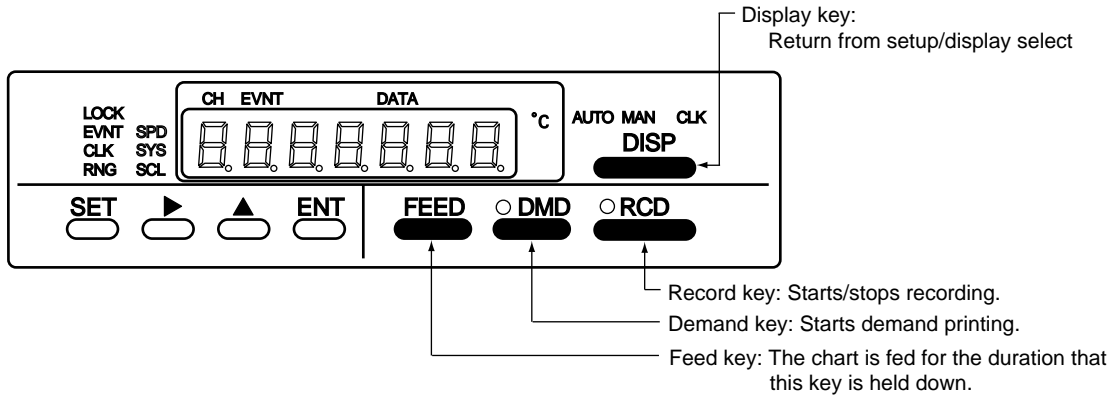

● Operation display

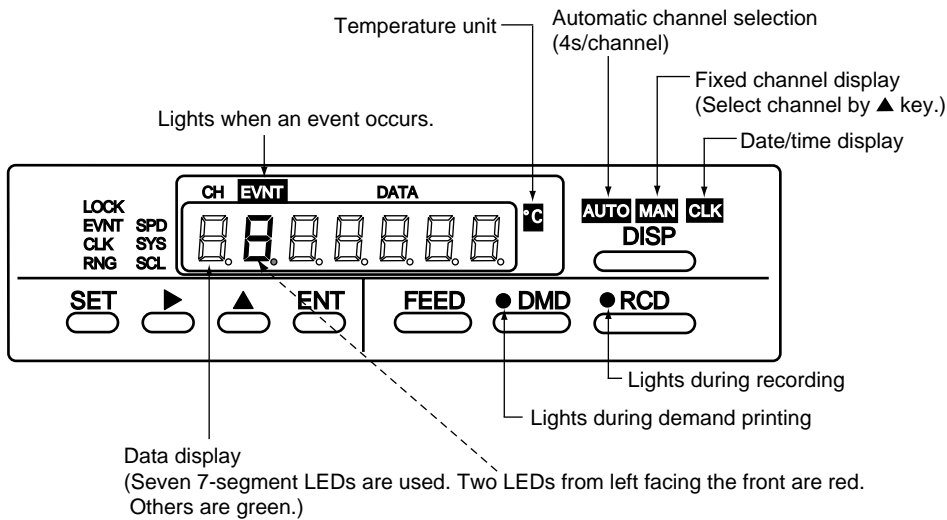

Display examples



AUTO or MAN indicates PV input value.
The example on the left shows a value of 18.0 for channel 1.

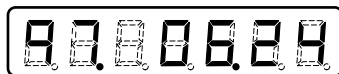

CLK indicates the date.
The example on the left shows the date June (06) 24th (24) 1997 (97)
In this example, the 7 in 97 is displayed red.



CLK indicates the time.
The example on the left shows the time 13:28 .

■ Configuration Unit and Operation Keys

The following describes the configuration unit on the display setup unit:

● Setup keys

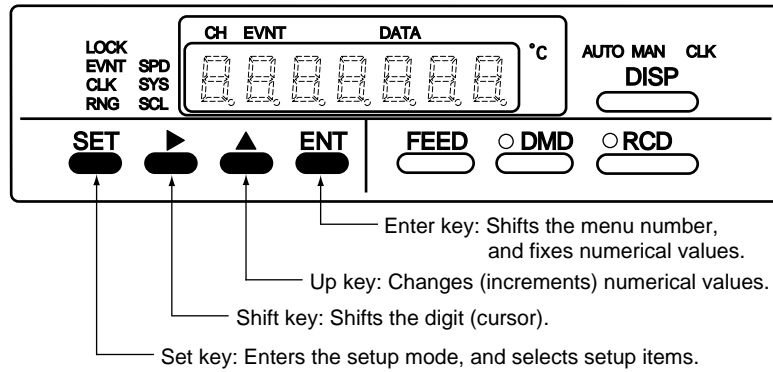

● Setup display

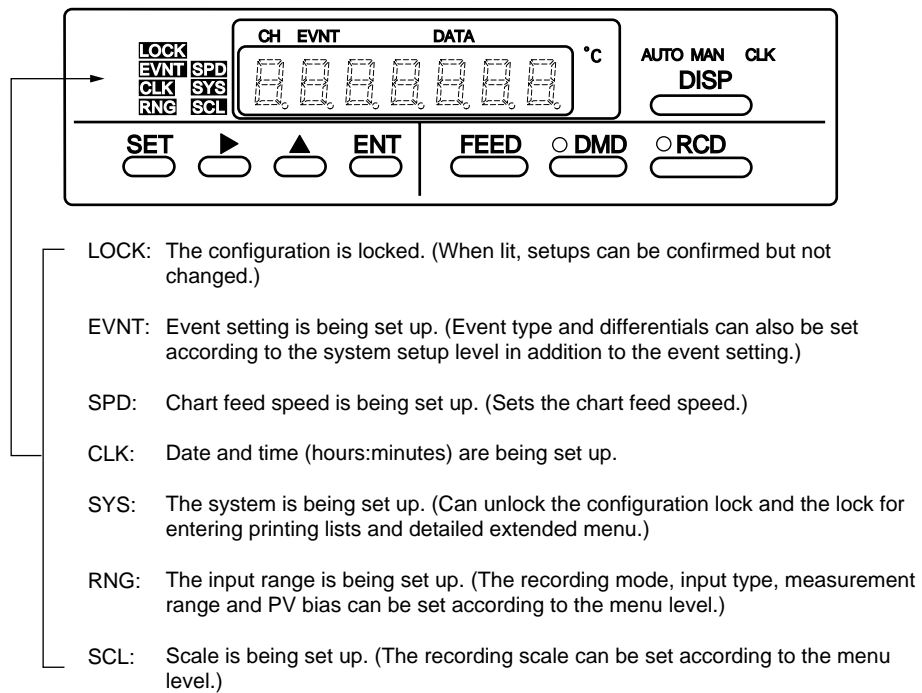

Display examples

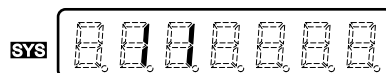

Setting configuration lock in the system setup level

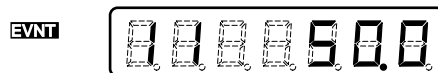

Checking or setting events:
In the example on the left, the setting of event setup 1 on channel 1 is 50.0.



Checking or setting the chart feed speed:
In the example on the left, the chart feed speed 1 setting 5 is 40mm/h.

Chapter 3. INSTALLATION & WIRING

3 - 1 Installation Site

■ Siting Conditions

The SRF106 is for indoor installation only. Install the SRF106 at a location that satisfies the following conditions:

- (1) Locations that are hardly subject to temperature change. Locations close to room temperature
- (2) Locations that are not subject to corrosive gas
- (3) Locations whose humidity is neither too low nor too high
- (4) Locations that are hardly subject to mechanical vibration
- (5) Locations that are hardly subject to dust or oil smoke
- (6) Locations that are hardly subject to the influence of electrical noise
- (7) Locations that are not subject to magnetic fields

! Handling Precautions

- Keep the mounting angle to within 0 to 30° from the bottom rear (bottom rear angle) or to within 0 to 3° from the top rear (top rear angle).
- Use a panel of at least 2mm in thickness for mounting the SRF106.

● When mounting from bottom rear

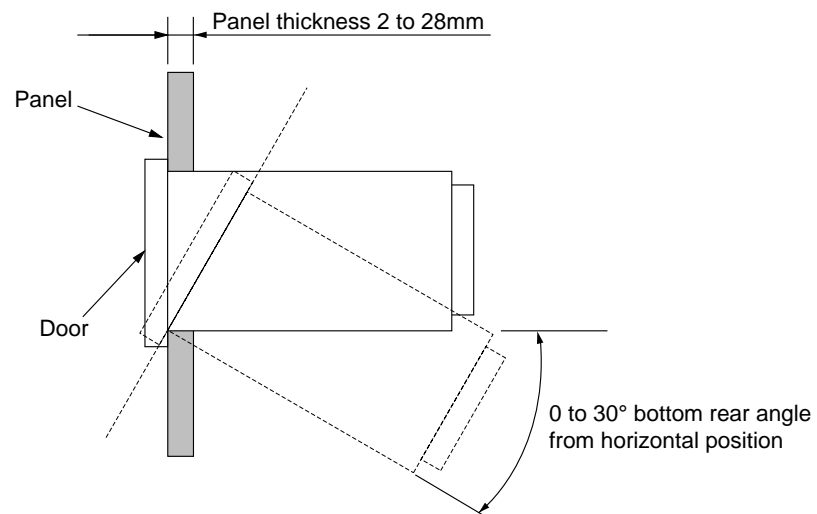

● When mounting from top rear

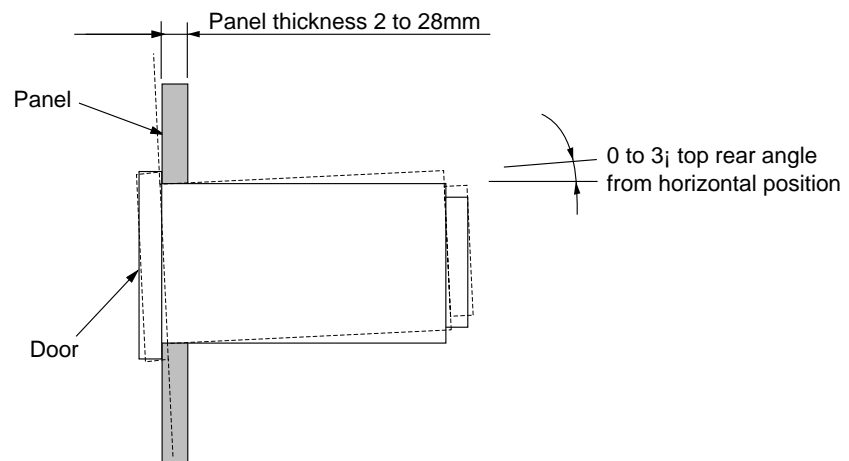

3 - 2 Installation

■ Installation Dimensions

The panel cutout dimensions are as follows:

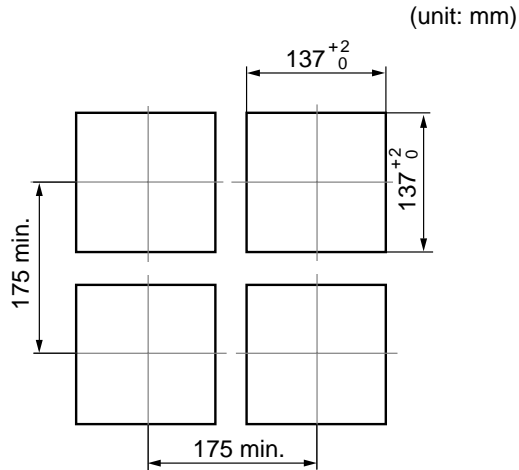

■ Installation Procedure

Use one of the mounting holes at the top, bottom, left or right of the case when mounting the SRF106.

- (1) Remove the seal covering the mounting hole to be used.
- (2) Insert the main unit case from the panel front.
- (3) Install the SRF106 onto the panel using the mounting brackets (provided).

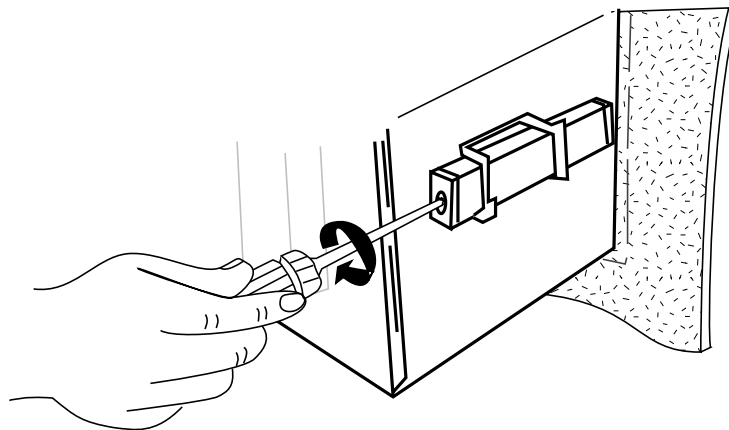







! Handling Precautions





- Remove the seal from only the mounting hole to be used when installing the SRF106. Do not remove the seals from the other mounting holes where the mounting bracket is not to be installed. These seals prevent dust from entering the case.
- The recommended tightening torque for the mounting bracket is 1.0 to 1.5N•m. Tightening the mounting bracket with a torque higher than this might deform the case or damage the mounting fixture.

3 - 3 Wiring Precautions

WARNING





-  Before wiring the SRF106, be sure to turn the power OFF. Failure to do so might cause electric shock depending on the power voltage.
-  Before connecting the SRF106 to the measurement target or external control circuits, make sure that a protective ground terminal is connected to the SRF106. Failure to do so might cause electric shock or fire.
-  Before wiring the SRF106, also turn the power supply for the event leads OFF. Power is sometimes supplied to the event leads even if the SRF106 power is OFF, which might cause electric shock depending on the power voltage.
-  After wiring the leads to terminals, do not allow lead clippings to fall into mounting bracket holes or ventilation holes. Failure to do so might cause internal circuits to short-circuit or cause a fire.
-  Before wiring the SRF106, check the model numbers of instruments (including options) and terminal numbers on the affixed labels. When you have finished wiring, check the numbers again. Wiring the wrong lead to the wrong terminal might damage the main unit or cause a fire.
-  Be sure to attach the terminal cover after wiring the SRF106. Failure to do so might cause electrical shock. If you lose the terminal cover, attach an equivalent countermeasure or obtain a maintenance part.

CAUTION

-  Do not use unused terminals on the SRF106 as relay terminals.
-  Use crimped solderless terminals that fit on M3.5 or M4 screws.
-  Adopt sufficient noise countermeasures to prevent malfunction caused by electrical noise.
-  Maintain a distance of at least 50cm between input signal leads and power leads of 100V or more. Also, do not pass these leads through the same piping or wiring duct.

■ Description of Symbols on Terminal Layout Label

The following table describes the meaning of symbols indicated on the terminal layout label on the SRF106:

Symbol	Meaning
	Alternating current (AC)
	Protective ground
	Danger of electric shock
	Caution

■ Noise Countermeasures

Digital equipment is easily influenced by electrical noise. Conditions that are not a problem on analog equipment might cause digital equipment to become damaged or malfunction.

When wiring, pay sufficient attention to the following items to prevent the influence of electrical noise:

⚠ CAUTION



Maintain a distance of at least 50cm between input signal leads and power leads of 100V or more. Also, do not pass these leads through the same piping or wiring duct.

● Noise generating sources

Generally, the following generate electrical noise:

- (1) Relays and contacts
- (2) Solenoid coils, solenoid valves
- (3) Power lines (in particular, 100Vac min.)
- (4) Induction loads
- (5) Motor commutators
- (6) Inverters
- (7) Phase angle control SCR
- (8) Wireless communications equipment
- (9) Welding equipment
- (10) High-voltage ignition equipment

● Noise reducing countermeasures

- Provision of a CR filter for fast-rising noise
(Recommended CR filter: Yamatake Corporation Model No. 81446365-001)
- Provision of a varister for noise with a high wave height. However, note that the varister may become short-circuited when trouble occurs. Pay attention to this when providing a varister on the SRF106.

Recommended varister:

Yamatake Corporation Model No. 81446366-001 (100V)
81446367-001 (200V)

■ Recommended Crimped Terminal

Use crimped solderless terminals that conform to the following dimensions:

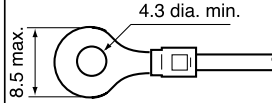
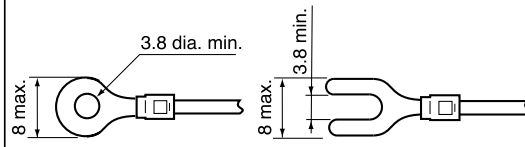
Terminal Name	Screw Dia.	Applicable Crimped Terminal (unit: mm)
Power terminals - Ground terminal	M4	 <p>4.3 dia. min. 8.5 max.</p>
Input terminal Relay output terminals (optional function) External switch input terminals (optional function) Communications terminal (optional function)	M3.5	 <p>3.8 dia. min. 8 max. 3.8 min.</p>

⚠ Handling Precautions

- The recommended tightening torque for used terminal screws is 1N•m and 0.4N•m for unused terminal screws. Tightening terminal screws using a torque higher than this might damage the terminal screws.
- When wiring with crimped solderless terminals, take care to prevent contact with adjacent terminals.

3 - 4 Connecting the Power Supply and Ground

- Use 600V vinyl-insulated power lead (JIS C 3307) as the power supply lead.
- Obtain the SRF106 power supply from a single-phase instrumentation power supply not subject to excess noise.
- If the power supply generates excessive noise, add an insulating transformer, and use a line filter.
(Recommended line filter: Yamatake Corporation 81446364-001)
- Keep the wiring from the line filter as short as possible. Bundling this wiring together is effective against electrical noise.
- After providing anti-noise countermeasures, do not bundle primary and secondary power leads together, or pass them through the same piping or wiring duct.

Connect the SRF106 by one-point grounding to the protective ground terminal. Do not perform any jump wiring. When it is difficult to ground shielded cables, prepare a separate ground terminal (earth bar).

- Grounding type: Lower than 100Ω
- Grounding conductor: Annealed copper wire more than 2mm^2 (AWG14) or equivalent or thicker wire
- Grounding conductor length: Max. 20m

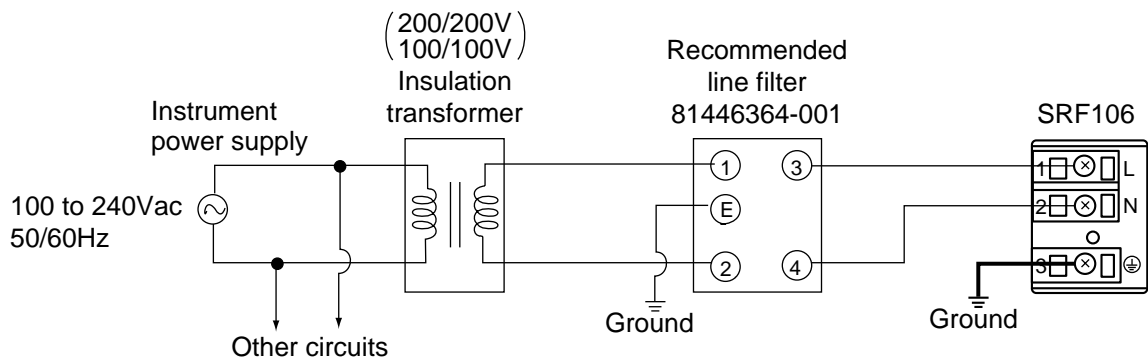

⚠ Handling Precautions

Take rush current into consideration when installing a power switch or use outside the SRF106.

3 - 5 I/O Signal Leads

(1) Thermocouple input signal lead

When the input is a thermocouple, connect the bare thermocouple lead to the terminal. If the thermocouple is located a long way from the SRF106, or the thermocouple is connected to a terminal, extend the connection using a compensating lead and then connect to the terminal. Use shielded compensating leads only.

(2) Resistance temperature detector (RTD)

- Use the three conductors.
- For the conductor, use JKEV-SB (JCS-364) shielded instrument polyethylene insulated vinyl sheath cable or equivalent product. (This is generally referred to as “twisted shielded cable for instruments.”)
- The wiring resistance is 10Ω or less per conductor.
- Balance the resistances of the three conductors so that they are the same values.

(3) Analog inputs other than thermocouple and resistance temperature detector (RTD) and digital I/O leads

- Use twisted shielded cable for instruments.
- Shielded, multi-core microphone cord (MVVS) can be used if there is little electromagnetic induction.



Note

- Use no-voltage contact inputs, and assign these contacts for minute currents. (input no-load voltage: approx. 5V, input short-circuit current: approx. 6mA)
- Hold contact signals for 0.5s or more.



Handling Precautions

Be careful not to short-circuit across communications terminals SDA and SDB, or across RDA and RDB. Otherwise, this might damage the communications path.

■ Wiring Analog Inputs

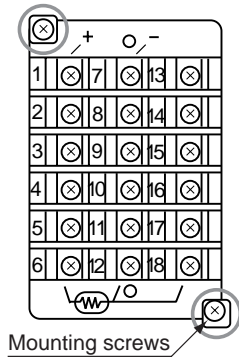

! Handling Precautions
Do not remove/disconnect the Analog Input Terminal Units. If removed damage may result.

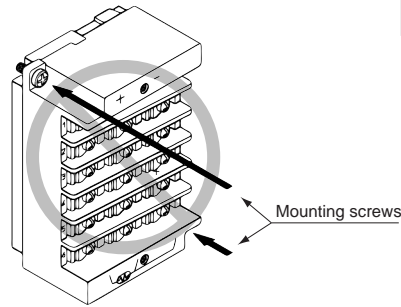

	Channel No.	Terminal No.		
Input terminals	1	1	7	13
	2	2	8	14
	3	3	9	15
	4	4	10	16
	5	5	11	17
	6	6	12	18
Connection	DC voltage			
	Thermocouple			
	Resistance temperature detector			

■ Wiring Event Outputs (optional function)

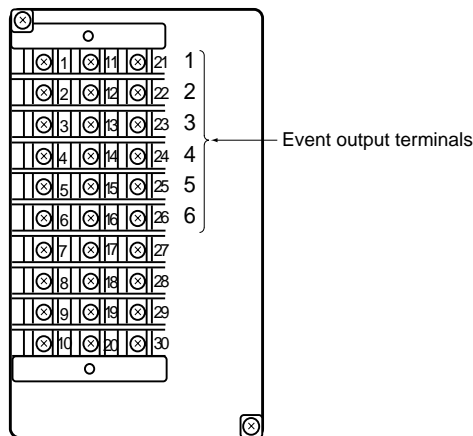

	Relay No.	Terminal No.		
Event output terminals	1	1	11	21
	2	2	12	22
	3	3	13	23
	4	4	14	24
	5	5	15	25
	6	6	16	26
Connection	Function	NO	C	NC
	Example: Lighting of lamp when event occurs			
Connection	Example: Lighting of lamp during normal operation			

■ Wiring External Switch Inputs (optional function)

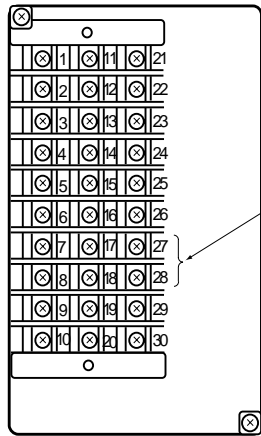

External switch input terminals

Input Terminals	Terminal No.		
	7	17	27
	8	18	28
Connection	<p>External switch input 1 External switch input 2</p> <p>7 No.1 17 Common 27 No.2</p> <p>(internally connected at terminal)</p>		
	<p>No.3 Common No.4</p> <p>8 No.3 18 Common 28 No.4</p> <p>External switch input 3 External switch input 4</p>		

■ Connecting the RS-485 Interface (optional function)

Read this item when you are using a model that supports the RS-485 communications function. The SRF106 is a slave station.

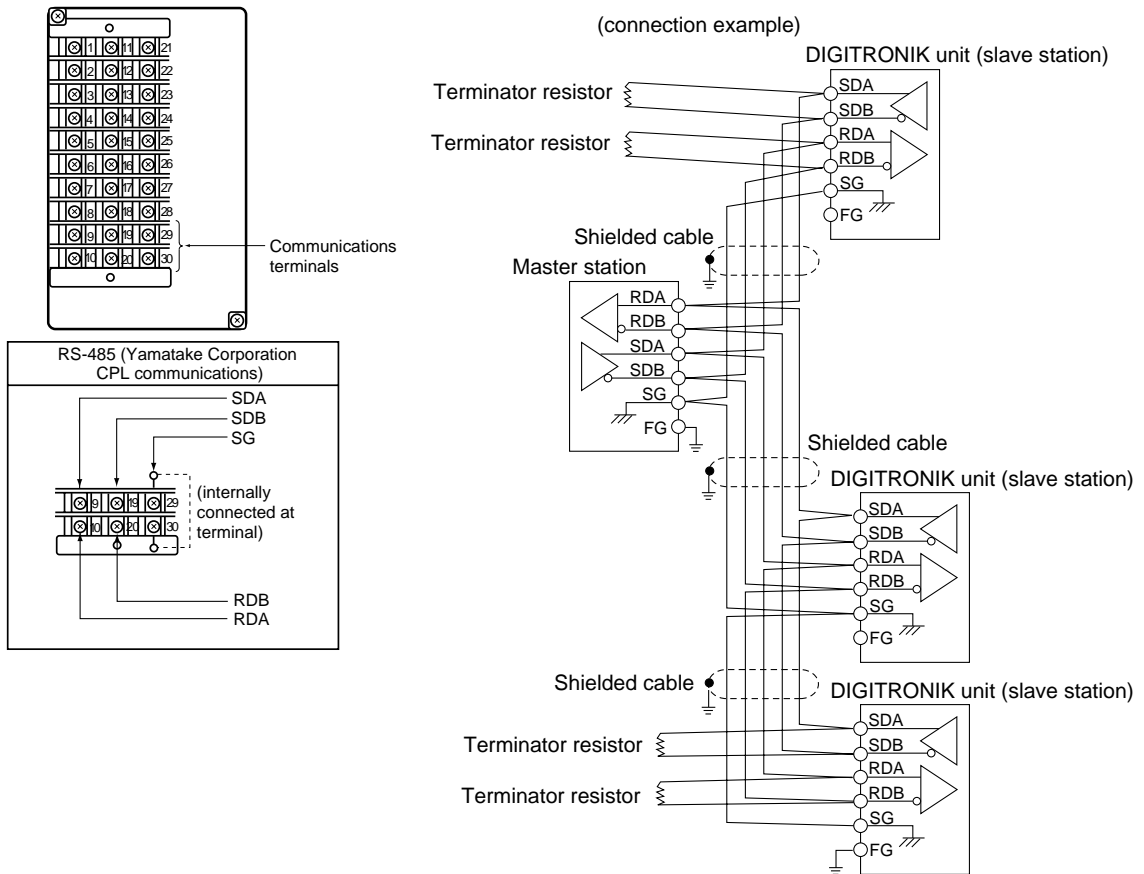

Provide terminators of resistance $150\Omega \pm 5\%$, 1/2W min. at both ends of the communications path.

Grounding of the shielded FG terminal should be carried out at only one end and not both ends.

■ Connecting the RS-232C Interface (optional function)

Read this item when you are using a model that supports the RS-232C communications function.

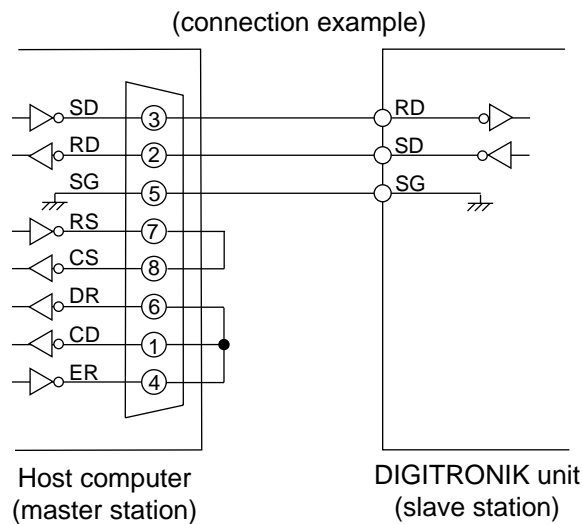
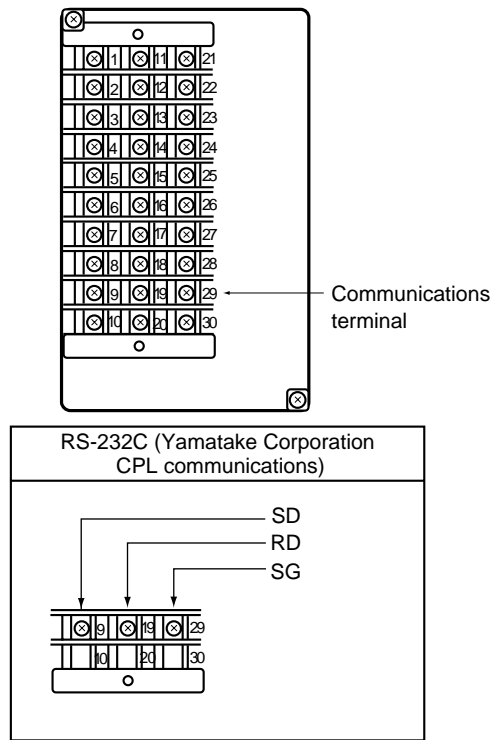

Note

Cable model No.: CBL232FNZ02

(2m cable for RS-232C, 9pin D-Sub socket contact—crimp-type terminal lug)

Chapter 4. PREPARATION & OPERATION

4 - 1 Preparation (loading the chart and ink ribbon cassette)

Before you start operation, load the folded chart (simply called “chart” from here on) and the ink ribbon cassette.

! Handling Precautions

Load the chart and ink ribbon cassette either with the power OFF or the recorder in a recording stop state.

To set the recorder to a recording stop state, press the  key. Recording stops, and the RCD LED goes out.

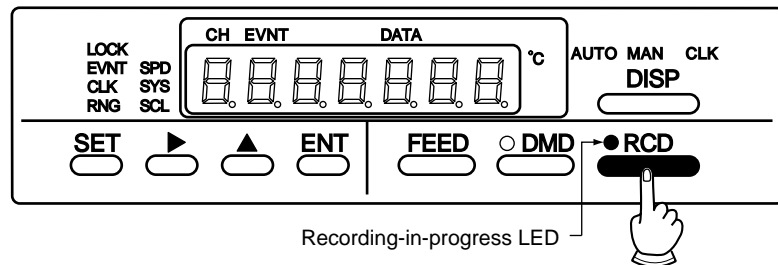

If the LED is lit, press the  key to set the recorder to a recording stop state.

■ Loading (replacing) the Chart

- (1) Before you load the chart, lightly fan the chart as shown in the figure below:



- (2) Open the door, and draw out the load lever on the chart cassette towards you.

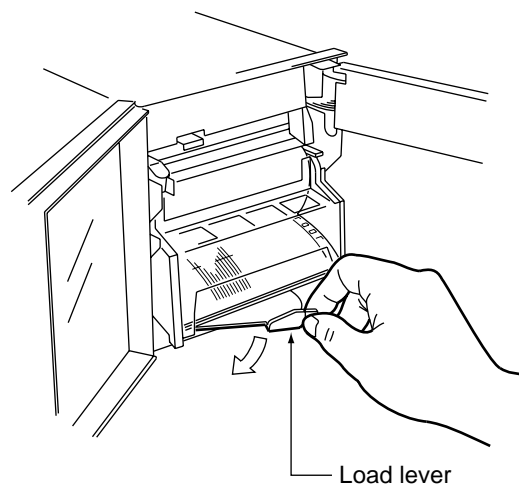

- (3) Draw out the chart cassette.

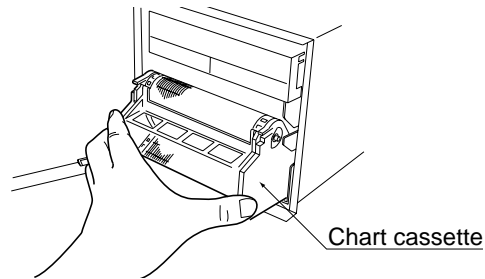

- (4) Open out the chart guide (made of transparent plastic) using its bottom side as a fulcrum.

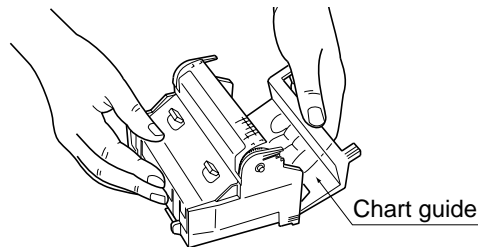

! Handling Precautions

The chart guide opens out from both the top and the bottom. Open out the chart guide from the top side, for example, when replacing the chart. On the other hand, open out the chart guide from the bottom side to check the recorded details during recording. By opening the chart guide in this way, you can prevent the chart from rising up.

- (5) Open out the chart holder springs (made of stainless steel) while pressing down on the orange rubber grips slightly with your fingers to release the chart holder springs from the grooves on the left and right (that is, to unlock the latches).

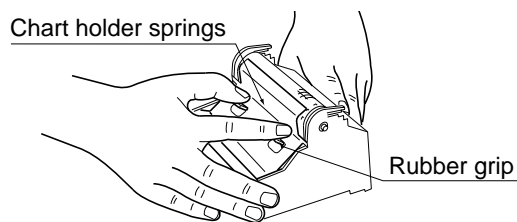

! Handling Precautions

Take care not to deform the spring section at the end of the chart holding springs.

- (6) Insert the chart into the chart holder making sure of the direction that the chart faces, and draw its leading edge out towards the chart guide.

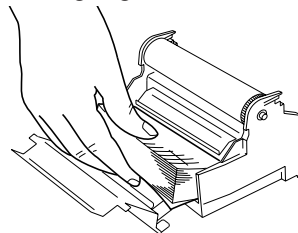

! Handling Precautions

A chart feed error will occur if the chart is not loaded correctly.

(7) Fit three to five folds from the leading edge of the chart on the tray on the chart guide side, and correctly align them on the sprockets.

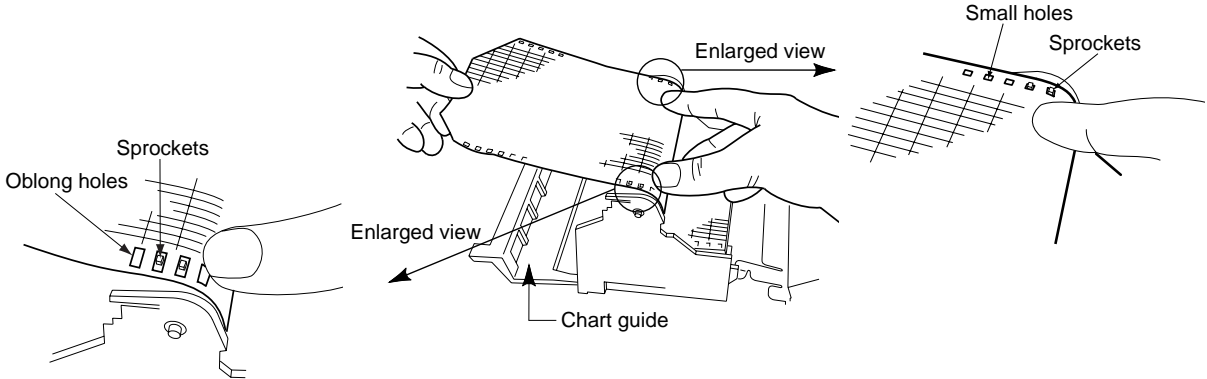

(8) Press in the chart holding springs as far as the latches on the left and right to load the chart.

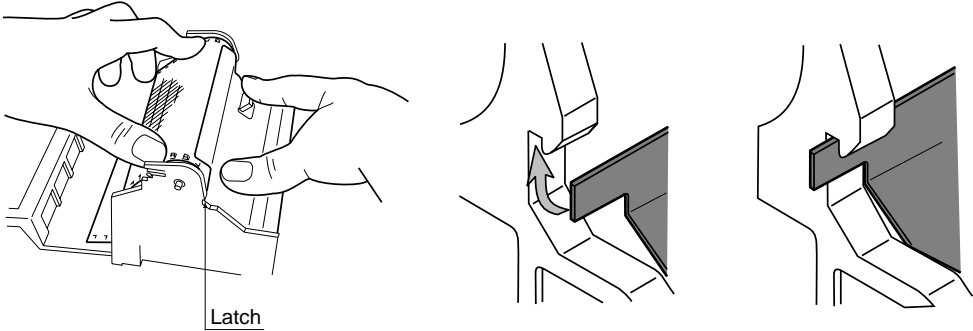

! Handling Precautions

Take care not to deform the spring sections at the end of the chart holding springs when returning them to their original positions.

(9) Push in the chart guide so that the left and right latches are firmly hooked, and close the chart guide.

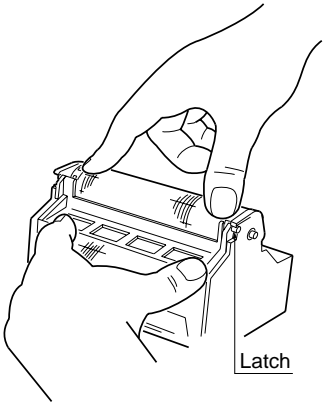

! Handling Precautions

Make sure that the time line on the chart is parallel with the top edge of the chart guide when viewed from the front.

- (10) Gently push the chart cassette into the body as far as possible, and then press in the load lever.

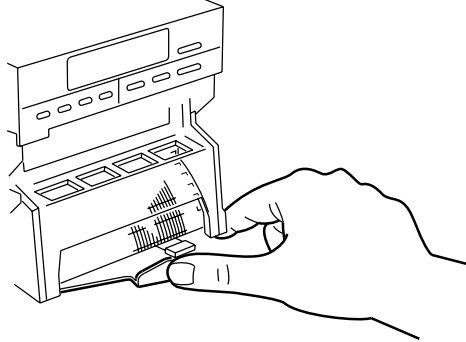

! Handling Precautions

- Before you start recording after you have removed and re-attached the chart cassette, press the **FEED** key to feed the chart about one fold to make sure that the chart is being fed correctly.

📖 Note

For details on the chart part No., see “ 1-2 Model Selection Guide” (page 1-3)

■ Loading (replacing) the Ink Ribbon Cassette

- (1) Open the door and open the display setup unit towards you by pulling on the protrusion at the bottom left of the unit.

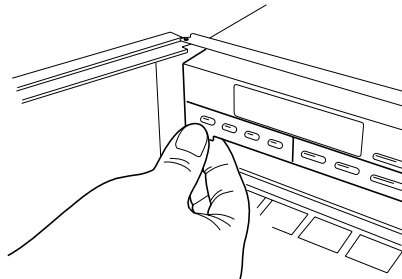

- (2) To replace the ink ribbon cassette, remove the old ink ribbon cassette. Push the release knob at the bottom left of the ink ribbon cassette up and swing the ink ribbon cassette out from the right side.

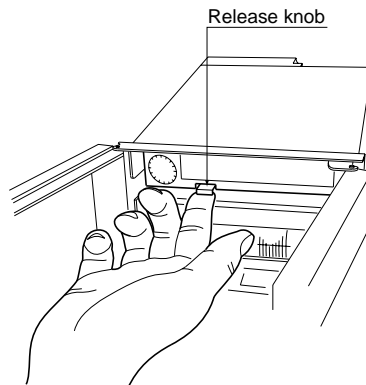

- (3) Insert the protrusion on the right of the new ink ribbon cassette into the hole on the ink ribbon cassette holder, and push in the release knob until you hear it click into place. The release knob enters the holder more easily if you push it in while rotating the ribbon feed knob.

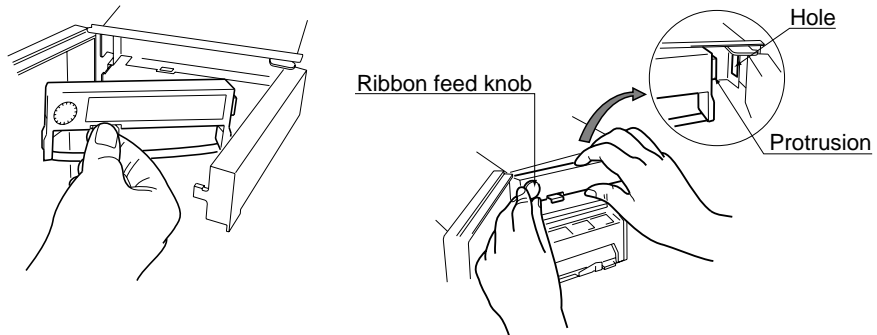

- (4) Make sure that the ink ribbon is inserted correctly between the wire dot head and the chart.

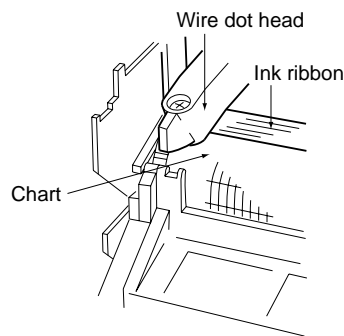

- (5) Check the ink ribbon for any slack. If there is any slack, turn the power OFF, and turn the ribbon feed knob on the ink ribbon cassette in the direction of the arrow (clockwise) to take up the slack.

! Handling Precautions

- You cannot turn the ribbon feed knob on the ink ribbon cassette when the power is ON.
- The ribbon will not be fed smoothly if the ink ribbon cassette is not loaded correctly. This may result in color drift or the ribbon becoming entangled in the wire dot head.
- When you are not using the recorder for a long time, remove the ink ribbon cassette, put it in a vinyl bag and seal the bag to prevent the ribbon from drying. If the ink dries, prints will be faint or recording may no longer be possible.

- (6) Return the display setup unit to its original position.

📖 Note

Model No. of ink ribbon cassette: 81406107-001 (1 p'ce)

4 - 2 Operation

■ Turning the Power ON

The recorder's power switch is located at the top right on the front when you open the door. Pressing the power switch turns the power ON, and pressing it again turns the power OFF. The internal check is automatically carried out within 60s of turning the power ON, and the recorder then enters the normal operating mode.

During the internal check, the display changes as follows:

All LEDs light, followed by the model No. indication, version indication and LED successive lighting.

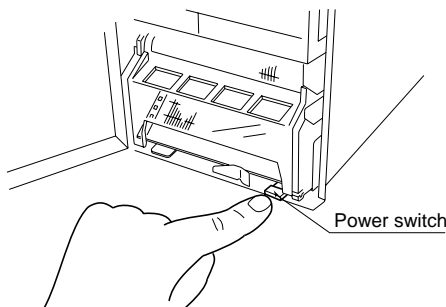

■ Starting/stopping Recording

To start/stop recording, press the **RCD** key.

If you press the **RCD** key, the LED on the key lights and recording starts.

If you press this key again, the LED goes out, and recording stops.

When recording starts, the following items are printed out. This is called "initial printing."

- Year/Month/Date (last two digits of Western calendar)
- Time (h/min)
- Recording format
- Chart feed speed
- Recorder ID No. (The ID No. is not printed when "00" is set as the ID No.)

However, initial printing is not carried out when the power is turned OFF and then ON again in a recording start state.

At this time, the chart is automatically fed about 1mm, and then recording is resumed. The same operation is carried out in the event of an instantaneous power interruption.

The recording stop/start state is held in memory even if the power is OFF. The same status is returned to when power is next turned ON.

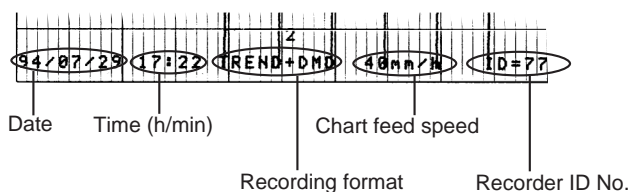
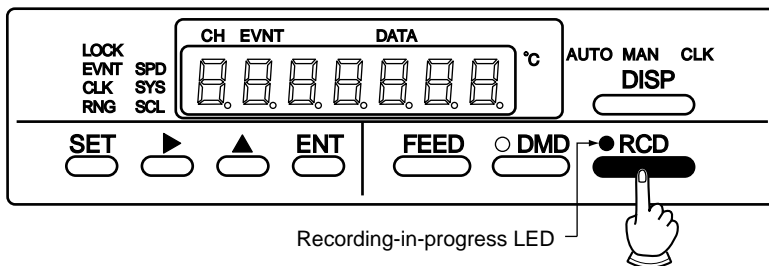

■ Feeding the Chart

To feed the chart forwards when recording is stopped, hold down the **FEED** key. To stop chart feed, release your finger from the key.

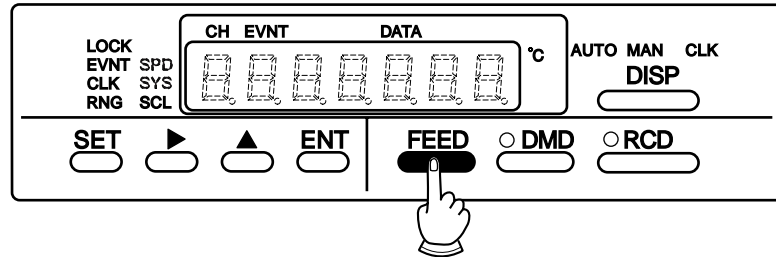

! Handling Precautions

- You cannot operate the **FEED** key during recording.
- You cannot feed the chart backwards. To feed the chart backwards, remove the chart cassette, manually fold back the chart to its original position, and load the chart cassette into the main unit again.

■ Selecting the Display Mode

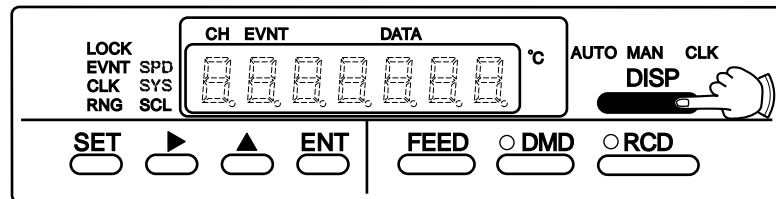

You can select four display modes by pressing the **DISP** key.

◇ AUTO indicator

This mode successively displays the PV value of each channel at 4s intervals.

◇ MAN indicator

This mode displays the PV value of specific channels. To move to the next channel, press the **▲** key.

◇ CLK indicator (year/month/date)

This mode displays the date.

◇ CLK indicator (time)

This mode displays the time.

■ Recording a Specific Table

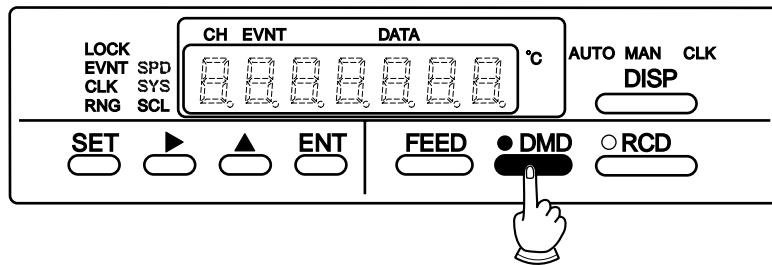

You can record a table (tabulation) of current PV values by pressing the **DMD** key.

During recording : A table of PV values is recorded overlaying trend data. The tabulation time varies according to the chart feed speed.

During recording stop : Tabulation starts immediately, and ends in about 1min.

To cancel tabulation midway, press the **DMD** key again.

Pressing this key immediately stops tabulation. If you press this key during a recording stop, tabulation starts. If you press the **RCD** key during tabulation, recording starts after tabulation ends.

(recording example when the **DMD** key is pressed during recording)

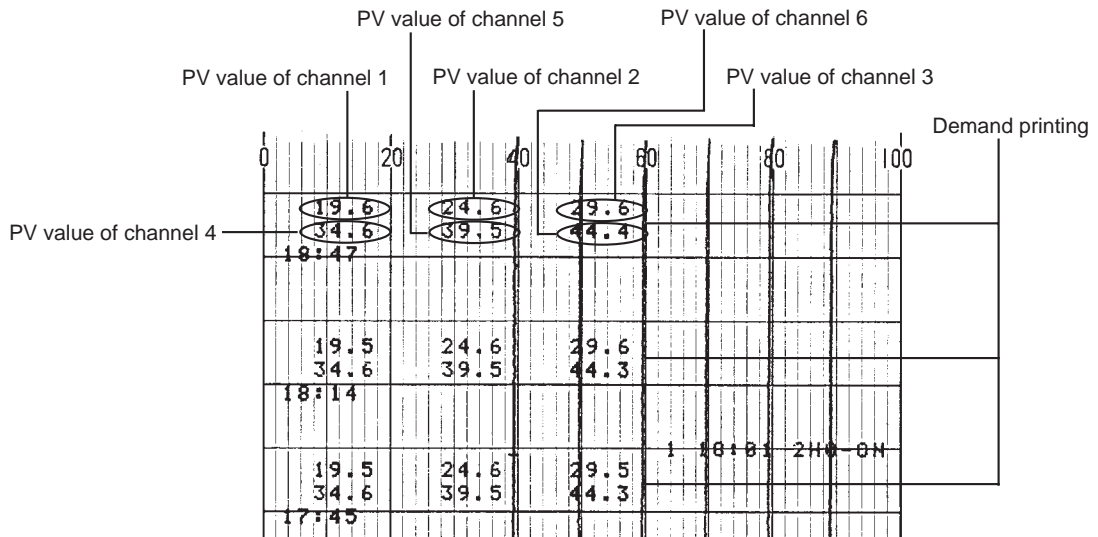

(recording example when the **DMD** key is pressed during a recording stop and the **RCD** key is pressed during tabulation)

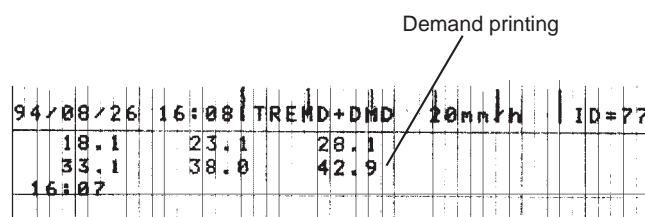

■ Other Displays and Operations

● Display when an event occurs

When an event occurs, the EVNT red LED lights.

When the display mode is set to AUTO or MAN, the status of the event is displayed for the channel where the event occurred.



(Example)

The **H** (HIGH) event occurs on channel 1
(PV value: 520.4)

 : HIGH (upper limit) event

 : LOW (lower limit) event

 : HIGH and LOW occur simultaneously

● Configuration lock

“Configuration lock” is a feature for preventing the user from changing configuration setups by mistake. When the configuration is locked, setups can be confirmed but not changed.

When the configuration is locked, the LOCK LED lights. For details on how to cancel configuration lock, see ■ Canceling the Configuration Lock (page 5-4).

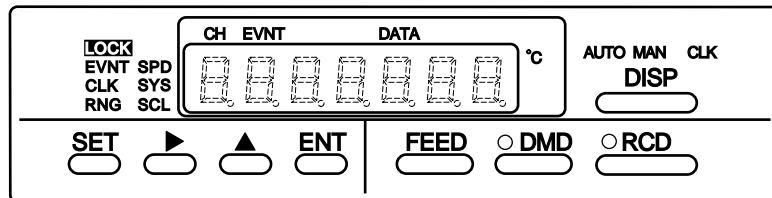

Printout Details

Printout messages (purple)

Note

For details, see 6-12 Printout Messages (page 6-23).

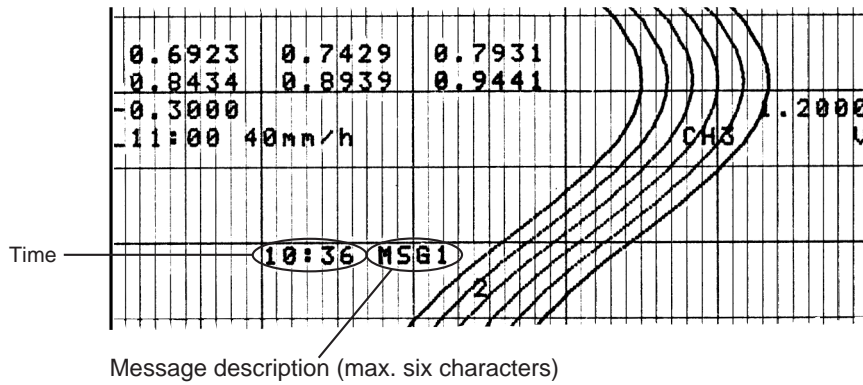

Example of trend + tabulation recording

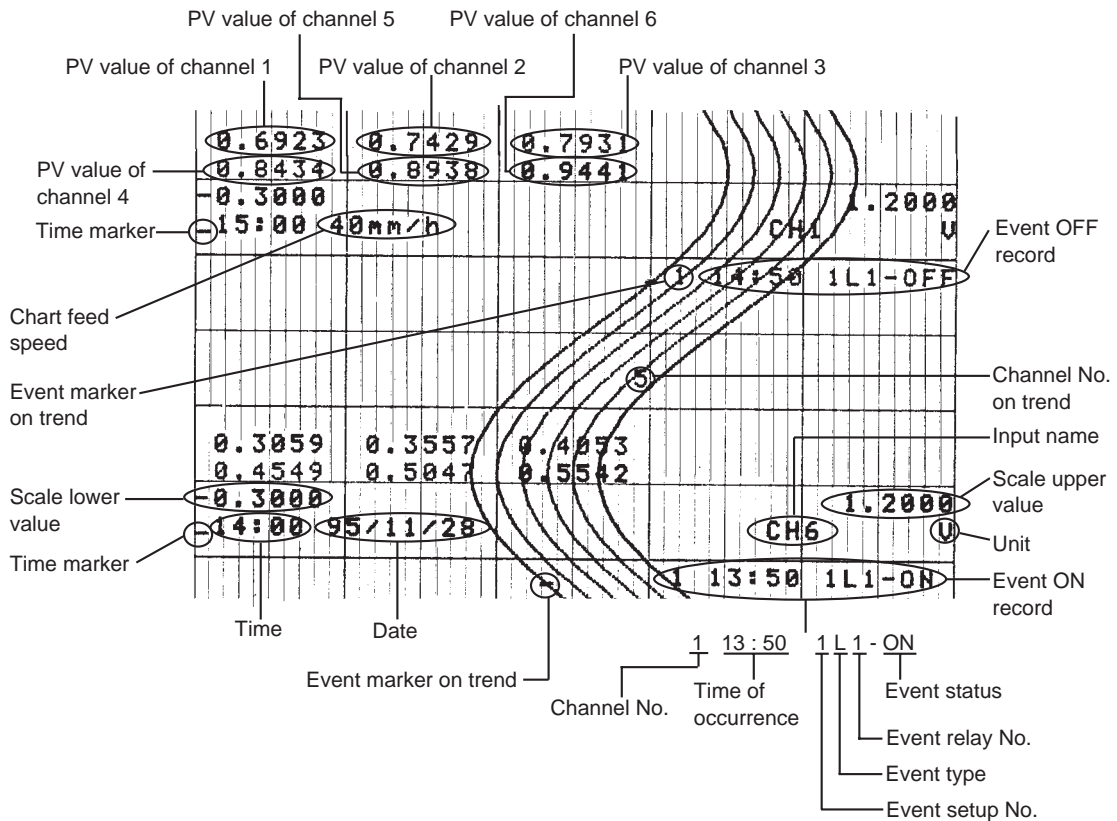

Chapter 5. BASIC CONFIGURATION

5 - 1 Introduction

To use the SRF106, you must first select the input range type, and set the recording scale, chart feed speed and other items. This setup is called “configuration.”

Configuration is sometimes already set up by the device manufacturer in which the SRF106 is integrated. If the SRF106 has not been configured or you want to change the configuration setups, refer to Chapter 6, DETAILED CONFIGURATION.

On the SRF106, configuration is divided into two stages:

- For personnel who normally operate the SRF106
- For personnel who initially set up the SRF106.

This chapter describes the setup items listed below whose settings are changed relatively often in normal operation. When the extended menu is set to OFF, four setup items (event setting value, chart feed speed, date/time and list printing) can be set. This chapter describes these setup items.

When the extended menu is set to ON, input range type, recording scale, recording format selection, event type and system setup can also be set. Chapter 6, DETAILED CONFIGURATION describes all of these setup items.

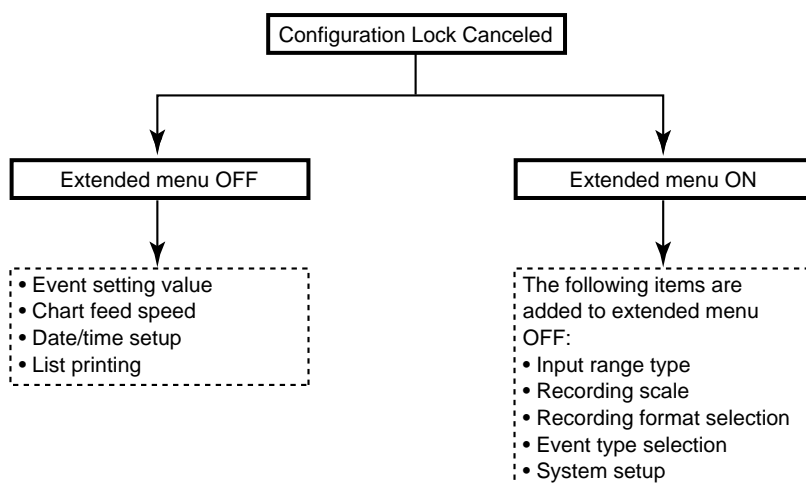

Note

When the configuration is locked, setups can be displayed for confirmation but not changed. (The configuration lock can be canceled at any time.)

Handling Precautions

Data setups can be changed during recording. However, note that once range type or other items are changed, display or recording sometimes malfunctions temporarily.

5 - 2 Basic Key Operations at Setup, Configuration Lock and Extended Menu

■ Basic Key Operations at Setup

This section describes common operations at setup.

- To start configuration setup

Press the  key.

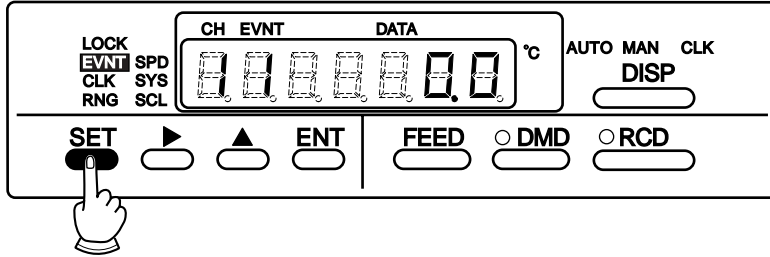

- To change configuration items

Press the  key to advance to the next display number.

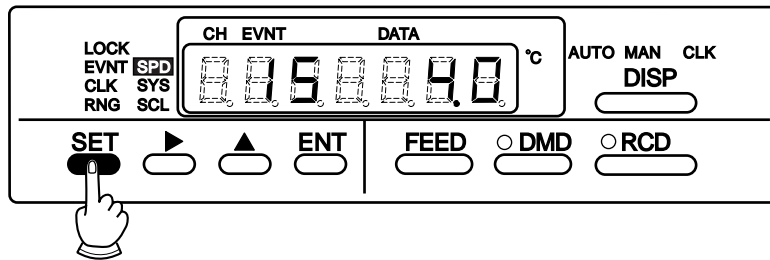

- To quit configuration

Pressing the  key in any situation quits configuration.

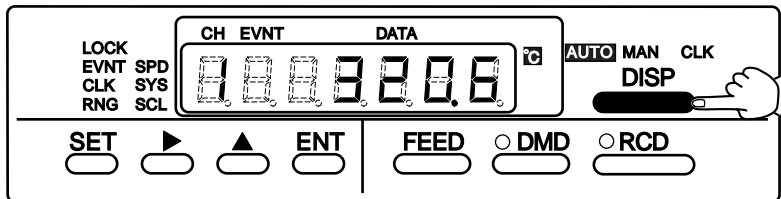

● To advance to the next display number

When you press the **ENT** key, the setting value is stored and the setup procedure advances to the next step.

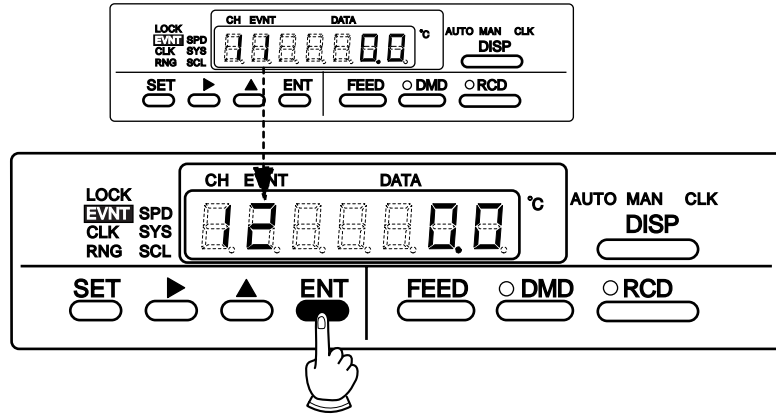

Note

If you have not changed the numerical values of a setup item, pressing the **ENT** key shifts the display number without changing the setup.

● To change data

Shift the cursor (blinking digit) using the **▶** key, press the **▲** key to fix the data, and set the data with the **ENT** key.

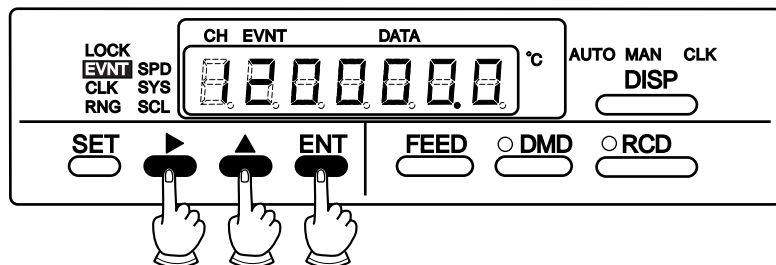

Note

To cancel changing of data midway, press either of the following keys without pressing the **ENT** key. Any changes made to the currently displayed data at this time are implemented.

DISP key: Quits configuration

SET key: Advances to the next setup.

■ Canceling the Configuration Lock

When the configuration is locked, the LOCK LED lights and the configuration setup cannot be changed. To cancel configuration lock, follow the procedure below:

- Press the **SET** key to select SYS.

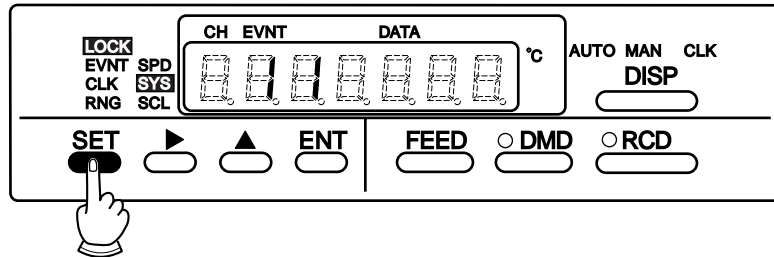

- Change the configuration lock setting from “1” to “0” in display No.1.

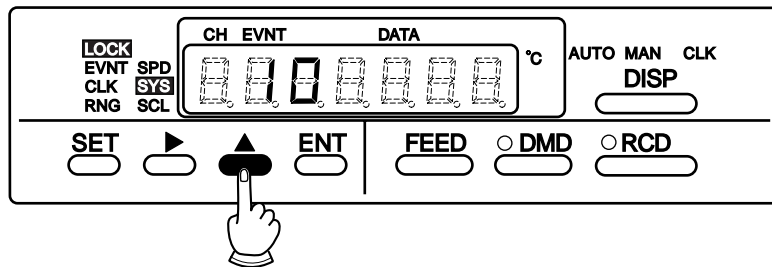

- Press the **ENT** key.

The LOCK LED goes out to indicate that the configuration lock is canceled.

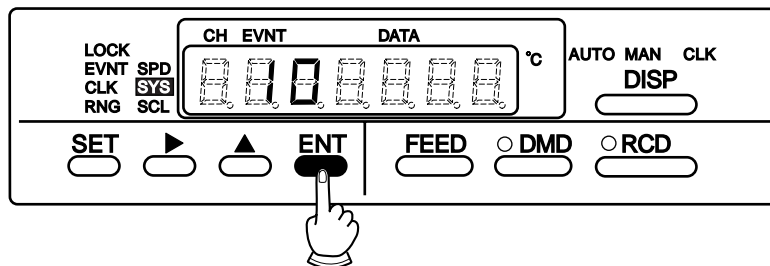

■ Switching the Extended Menu ON/OFF

To set initial settings such as range type and recording scale on the SRF106, turn the extended menu ON.

- Press the  key to select display No.3.

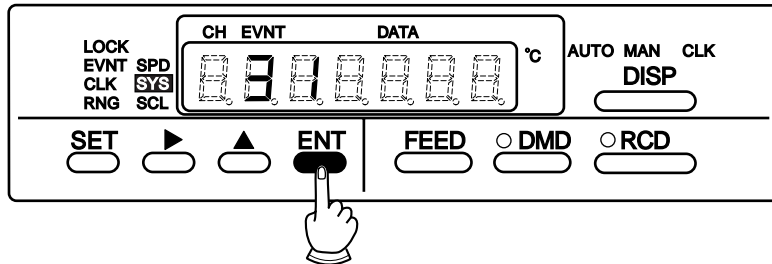

- Change the extended menu setting from "1 (ON)" to "0 (OFF)".

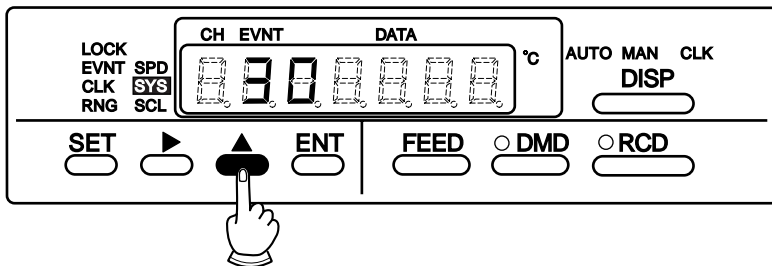

- Press the  key.

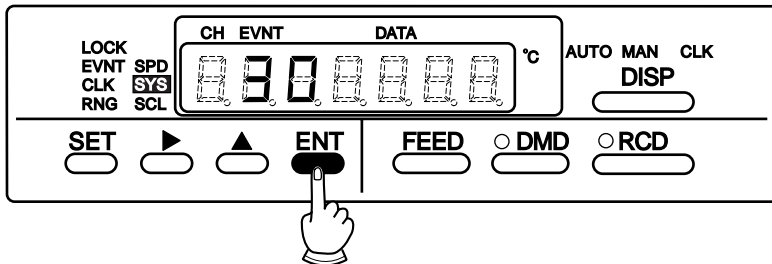

5 - 3 Changing Event Setting Values

! Handling Precautions

Event setting values are displayed only when “H” or “L” is set as the event type.

For details on how to set up event types, see 6-3 Event Setup (page 6-4). The decimal point position of event setting values is the decimal point position determined by the range code in the case of range codes 10 onwards. In the case of range code 00 to 06 voltage inputs, this becomes the engineering range decimal point position, range setup procedure display No.8 (page 6-3).

■ Starting Setup

Press the **SET** key to select EVNT. (Make sure that the EVNT LED lights.)

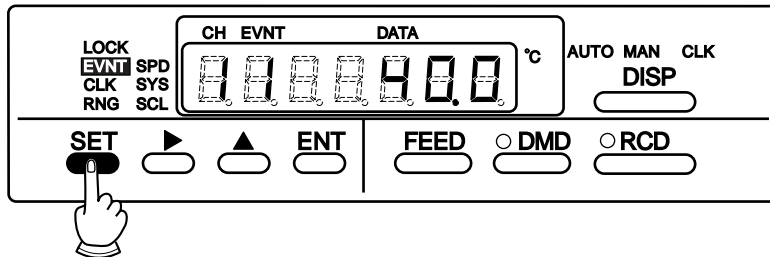

■ Selecting the Target Channel No.

Select the channel No. to be set using the ▲ key.

The following example shows the display setup unit when channel 2 is selected:

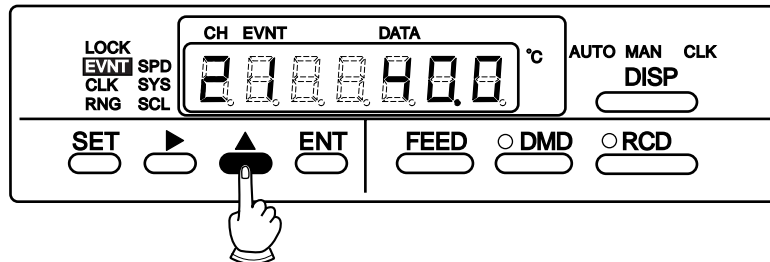

■ Selecting the Target Event No.

Up to four events can be set to a single channel. Select which event No. is to be set. Event No.1 will be displayed with the target channel selected.

After you have entered the setting value, press the **ENT** key. Event No.2 is displayed.

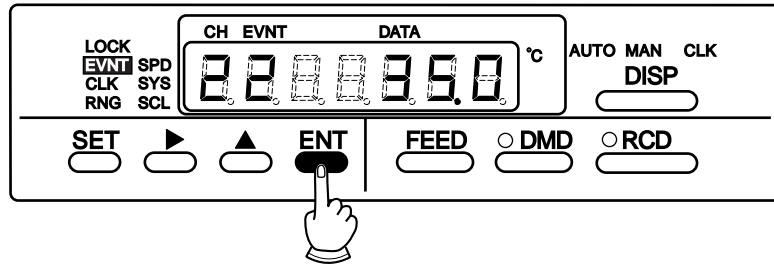

Note

If you press the **ENT** key without setting any value, the next event No. will be selected.

■ Enabling Changing of Event Setting Values

- When you can select the target event No. of the target channel, you can change that event setting value. If you press the **▶** key, the cursor moves from the CH display to the uppermost digit of the setup item at DATA.

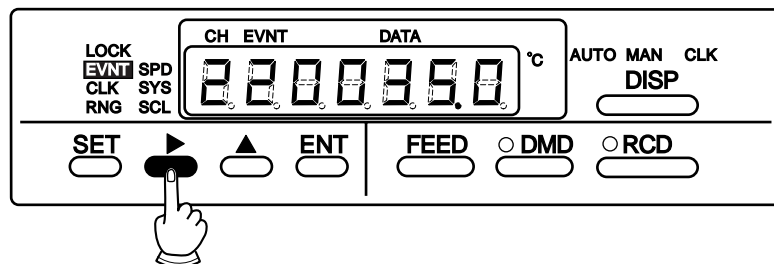

■ Entering the Setting Value Using the **▲/▶** Keys, and Pressing the **ENT** key

Enter event setting values using the **▲** or **▶** keys.

When you have set the numerical values, press the **ENT** key. This registers the setting value to memory, and automatically advances the display to the next event number.

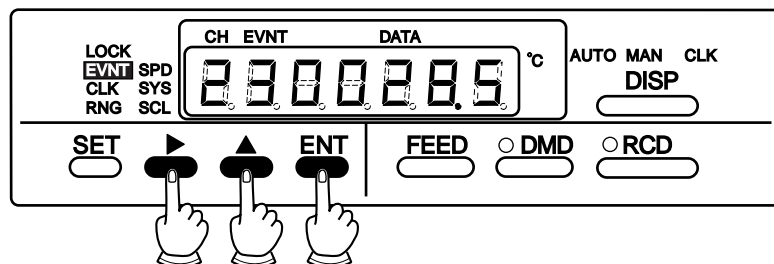

5 - 4 Changing the Chart Feed Speed

Handling Precautions

Chart feed speed 2 is displayed only when the extended menu is turned ON.

■ Starting Setup

- Press the  key to select SPD. (Make sure that the SPD LED lights.)

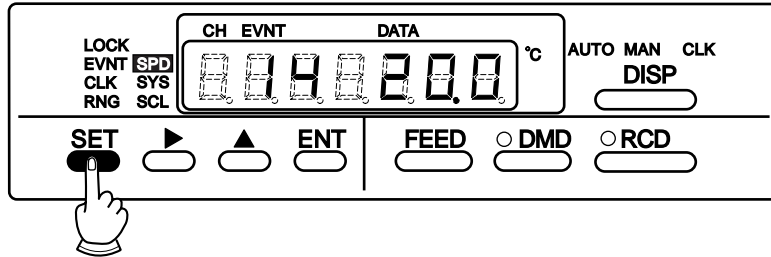

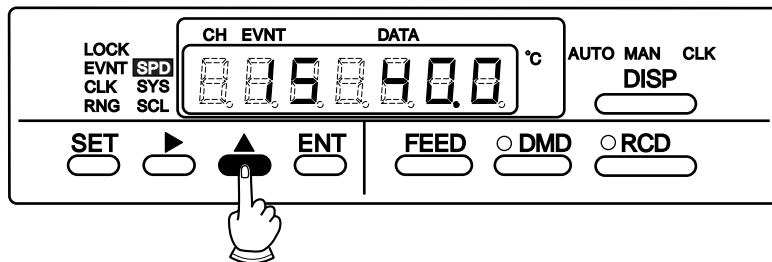

■ Changing the Chart Feed Speed

- Press the  key to select the target chart feed speed No. The chart feed speed corresponding to that chart feed speed No. is displayed to the right of the No.



■ Pressing the key

- When the  key is pressed, the cursor stops blinking momentarily, and the setting value is registered to memory. The chart feed speed is changed when the next scan executed by pressing the  key starts to be printed.

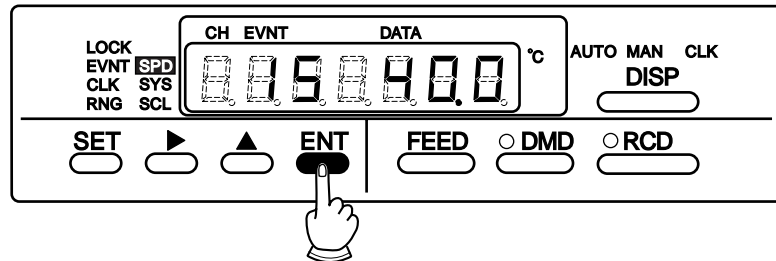

■ Chart Feed Speed No. and Chart Feed Speed

Chart Feed Speed No.	Chart Feed Speed Setting Display (mm/h)	Tabulation Recording Interval (trend + tabulation)
1	2.5	12h
2	5	12h
3	10	4h
4	20	2h
5	40	1h
6	60	1h
7	120	1h
8	240	Tabulation OFF

5 - 5 Changing the Date/Time

! Handling Precautions

If both the date and time are in error, all DATA LEDs will blink when you press the **ENT** key to notify that entry is no longer possible. If this happens, press any key to return to the entry display.

The number of seconds in the time setting is reset (so that counting starts from “00”) when you press the **ENT** key, only when the numerical values for the time setting are changed. If you press the **ENT** key without making any changes to the numerical values for the time setting, the date setting display will be redisplayed, and the number of seconds will not be reset.

■ Starting Setup

Press the **SET** key to select CLK. The LED for the selected items lights. Make sure that the CLK LED lights.

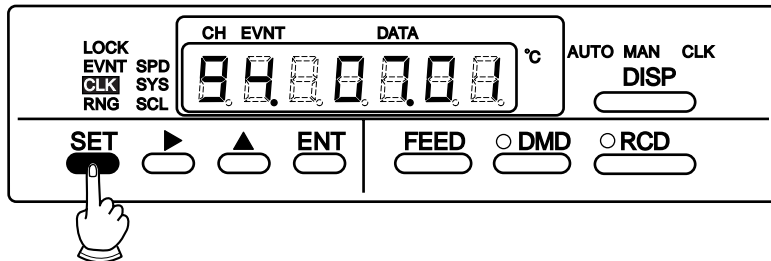

■ Changing the Date

The date is arranged in order year (lower two digits of Western calendar), month, then day. Shift the cursor to the part of this item that you want to change using the **▶** key, and change the numerical value using the **▲** key. Leap years in dates are automatically adjusted. To set the year “2000”, enter “00” as the year.

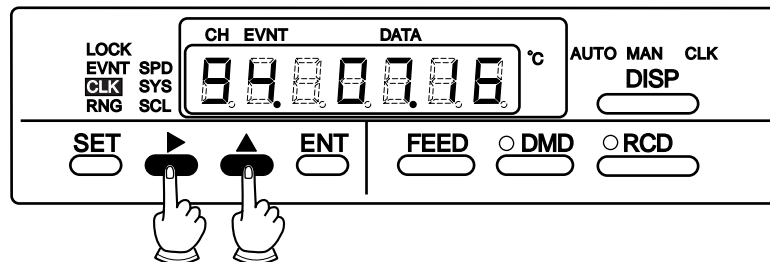

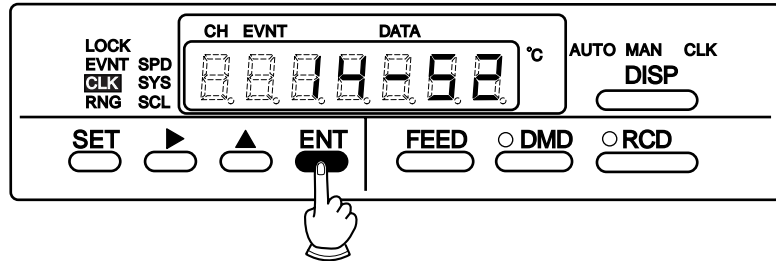

■ Pressing the key

- When the  key is pressed, the display advances to the time setup display.



■ Changing the Time

The time is arranged in order hours (24h clock) then minutes. Shift the cursor to the part of this item that you want to change using the  key, and change the numerical value using the  key.

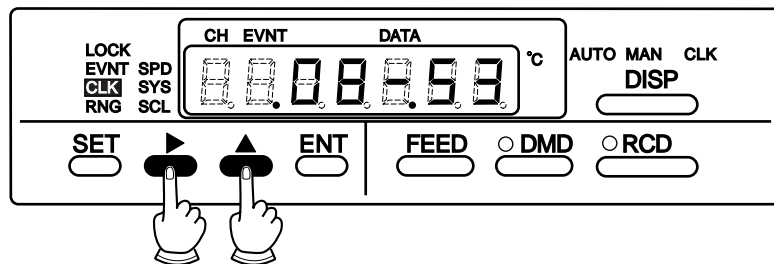

■ Pressing the key

- When the  key is pressed, the display advances to the date setup display.

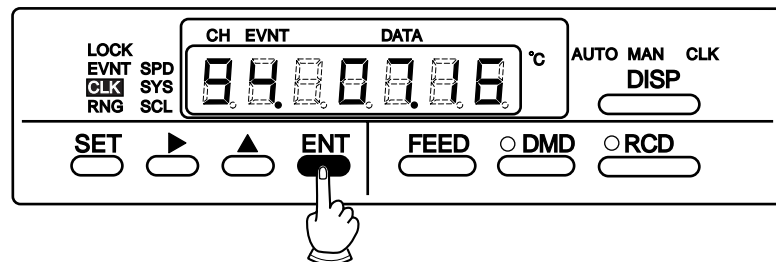

5 - 6 Printing Lists

Lists are printed for checking or saving setup details. There are two list printing modes, print specified list and print all list. The print specified list mode prints the minimum required information such as input type and recording scale, and event setting value. Whereas, the print all list mode prints all set details. To automatically start recording after printing a list, press the  key after you started printing the list. At this time, the RCD LED lights.

Handling Precautions

Printing of lists cannot be set unless recording has stopped. It takes about 4min to print a specified list and about 14min to printing an all list.

■ Stopping Recording

- Press the  key to stop recording midway.

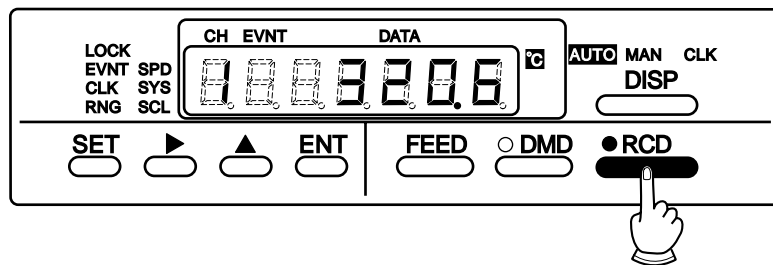

■ Starting Setup

- Press the  to select SYS. Make sure that the SYS LED lights.

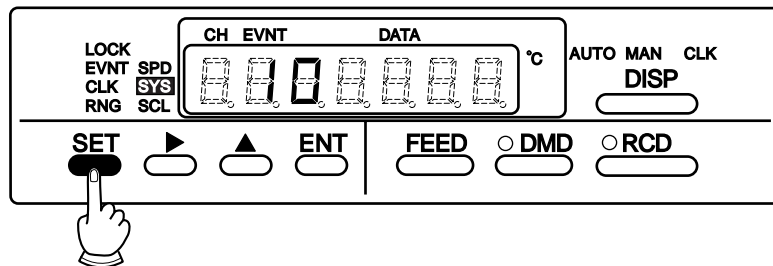

- Press the  key at display No.2 (printing lists) to continue setup.

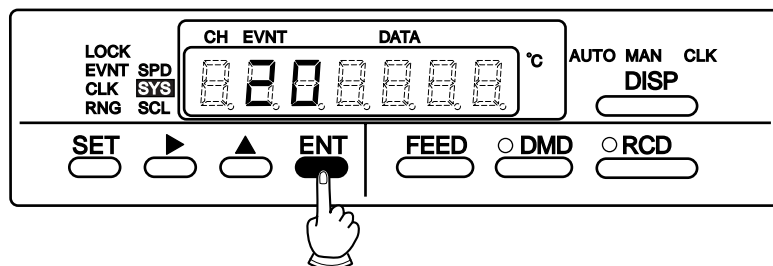

■ Selecting the List to be Printed

- Press the ▲ key to select 1 (specified list) or 2 (all list).
The following example shows how to print specified lists.

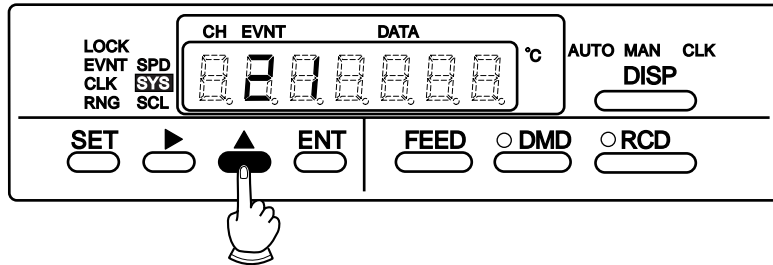

■ Pressing the key

- Press the  key to start printing the list.

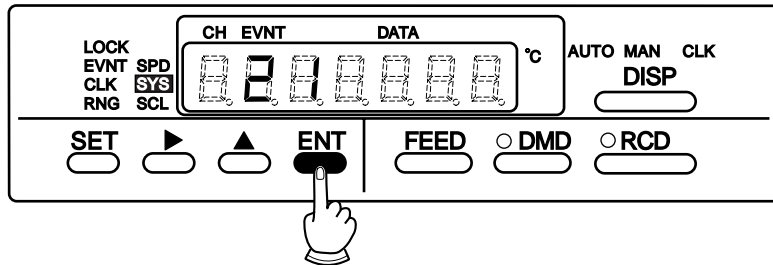

■ Stopping List Printing Midway

- The setup advances to display No.2. Press the ▲ key to select 0. Press the  key to stop printing the list.

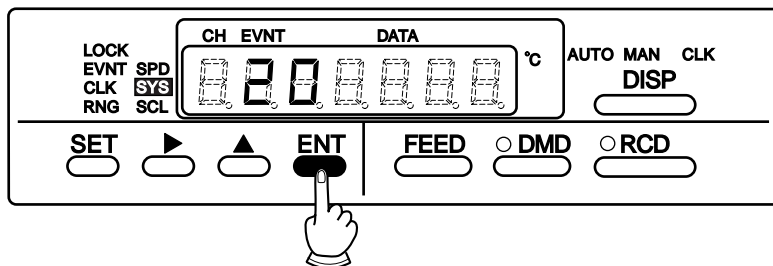

(example of specified list printing)

Date, Time, Recording format, Chart feed speed, Recorder ID No.

94/08/26 11:16 TREND+DMD 20mm/h ID=27						
CH	RANGE	CODE	SCALE		UNIT	
	EVENT1		EVENT2	EVENT3	EVENT4	
01	26:T			0.0	50.0	°C
	OFF		OFF	OFF	OFF	
02	26:T			0.0	50.0	°C
	OFF		OFF	OFF	OFF	
03	26:T			0.0	50.0	°C
	OFF		OFF	OFF	OFF	
04	26:T			0.0	50.0	°C
	OFF		OFF	OFF	OFF	
05	26:T			0.0	50.0	°C
	OFF		OFF	OFF	OFF	
06	26:T			0.0	50.0	°C
	OFF		OFF	OFF	OFF	

CH No., Range code, Recording scale lower limit, Recording scale upper limit, Unit No.1 event setting value, No.2 event setting value, No.3 event setting value, No.4 event setting value

(example of all lists printing)

Date, Time, Recording format,
Configuration lock ON/OFF, Chart
feed speed, Recorder ID No.,
Recording color selection, Extended
menu ON/OFF, Time + scale
printing ON/OFF

Input range type, Recording mode,
Input calculation type, Burnout, PV
bias reference channel, Fixed value
for deviation, Measurement range
(upper/lower value), Engineering
range (upper/lower value)

No.1 scale upper/lower value, No.2
scale upper/lower value, Scale
switching method, Auto-switching
point setting value, Auto-switching
differential setting value

```

97701/21 19:38 TREND+DND LOCK OFF ID#00
COLOR:STD MENU:STD CHARTSP1: 20mm/h
RCDCLOCK:ON SCALE:ON SP2:240mm/h
** RANGE **
CH MODE RANGE CODE CALC DEV CH/DATA
0 MEAS RANGE 40 PU BIAS 80 BURN OUT
ENG. RANGE TAG
01 RCD 20:R 1760.0 NORMAL 0.0 OFF
0.0 1760.0 TEMP-1
02 RCD 40:Pt100 650.0 NORMAL 0.0 OFF
-200.0 650.0 1440cm
2&MP-2
03 RCD 40:Pt100 650.0 NORMAL 0.0 OFF
-200.0 650.0 TEMP-3
04 RCD 40:Pt100 650.0 NORMAL 0.0 OFF
-200.0 650.0 TEMP-4
05 RCD 05:25V-LIN 5.000 NORMAL 0.0 OFF
1.000 5.000 10.0 TEMP-5
0.0 10.0
06 OFF 20 40 60 80 100
-200.0 1370.0 NORMAL 0.0 OFF
23:K UP TEMP-6
-200.0 1370.0
** SCALE **
CH SCALE1 CHG TYPE UNIT
SCALE2 POINT DIFF
01 0.0 1600.0 OFF °C
02 0.0 200.0 OFF °C
03 0.0 200.0 OFF °C
04 0.0 200.0 OFF °C
05 0.0 10.0 OFF k
06 0.0 1200.0 OFF °C
    
```

ROM revision No.

Channel No. tag

(continued on next page)

(example of all lists printing)

** EVENT **							
CH	NO	2SP	TOP	DOFF	RCD	RELAY	1450
01	1	40.0	HIGH	2.0	ON	OFF	
	2	20.0	LOW	2.0	ON	OFF	
	3	0.0	OFF	0.0	ON	OFF	
	4	0.0	OFF	0.0	ON	OFF	
02	1	35.0	OFF	0.0	ON	OFF	
	2	0.0	OFF	0.0	ON	OFF	
	3	0.0	OFF	0.0	ON	OFF	
	4	0.0	OFF	0.0	ON	OFF	
03	1	0.0	OFF	0.0	ON	OFF	
	2	0.0	OFF	0.0	ON	OFF	
	3	0.0	OFF	0.0	ON	OFF	
	4	0.0	OFF	0.0	ON	OFF	
04	1	0.0	OFF	0.0	ON	OFF	
	2	0.0	OFF	0.0	ON	OFF	
	3	0.0	OFF	0.0	ON	OFF	
	4	0.0	OFF	0.0	ON	OFF	
05	1	0.0	OFF	60.0	ON	OFF	100
	2	20.0	OFF	0.0	ON	OFF	
	3	0.0	OFF	0.0	ON	OFF	
	4	0.0	OFF	0.0	ON	OFF	
06	1	0.0	OFF	0.0	ON	OFF	
	2	0.0	OFF	0.0	ON	OFF	
	3	0.0	OFF	0.0	ON	OFF	
	4	0.0	OFF	0.0	ON	OFF	
MSB1:RCD on 2:RCDoff 3:skin< 4:skin> SCH.DMD1=09:00 2=17:00 COM R5485 R/W ADR:0 HADR:0 x x P33 DI ASSIGN NO1:1 NO2:2 NO3:3 NO4:4							

No.1 to No.4 event type, No.1 to No.4 relay No., No.1 to No.4 event setting value, Event differential setting value, Event printing ON/OFF selection

Message printing, Schedule demand time, DI function settings, Communications parameters

- Note 1) Input calculation type is printed as follows:
- | | |
|----------------------------------------------------------|-------------|
| Setting | Printout |
| 1: PV | NORMAL |
| 2: Channel deviation (reference channel—current channel) | DEV (CH.—) |
| 3: Channel deviation (current channel—reference channel) | DEV (—CH.) |
| 4: Fixed value deviation (fixed value—current channel) | DEV (DATA—) |
| 5: Fixed value deviation (current channel—fixed value) | DEV (—DATA) |
- Note 2) When the input calculation type is set to PV, both the reference channel and fixed value for deviation are not printed. When the input calculation type is set to channel deviation, reference channels targeted for deviation are printed, and when set to fixed value deviation, the fixed value for deviation is printed.
- Note 3) When the range code is set to thermocouple or resistance temperature detector, the engineering unit upper and lower limits are not printed.
- Note 4) When the scale switching method is set to “0” (OFF), the following items are not printed:
- No.2 scale 0% value and 100% value
 - Auto-switching point setting value
 - Auto-switching differential setting value
- Note 5) When the scale switching method is set to “2” (switching by external method), the following items are not printed:
- Auto-switching point setting value
 - Auto-switching differential setting value
- Note 6) On models that do not support the event output optional function, relay Nos. No.1 to No.4 are not printed.
- Note 7) The schedule demand time is printed only when the recording format is set to schedule demand.
- Note 8) On models that do not support the external switch inputs (optional function), the DI function setting is not printed.
- Note 9) Communications parameters are printed only on models that support communications (optional function).

Chapter 6. DETAILED CONFIGURATION

6 - 1 Introduction

This chapter describes how to set up configuration items that are initially set on the SRF106.

Set up configuration items with configuration lock unlocked (display No.1 in SYS setup).

If the extended menu is set to ON (display No.3 in SYS setup), you can also set up the range type, recording scale, recording format, event type and system setup.

Handling Precautions

- Configuration can be set up also during recording. However, if the range type or other setup items are changed, recording sometimes becomes temporarily abnormal.
- The Smart Handy Loader is needed to set the following functions. These functions cannot be set on the SRF106 alone:
 - Reference contact temperature compensation ON/OFF
 - External switch input function assignment extension (factory setting "ON")
 - Message printing details (factory setting "ON")

Note

For details on event setting values, chart feed speed, date/time setup and list printing to be configured with the extended menu OFF, see "Chapter 5. BASIC CONFIGURATION."

6 - 2 Configuration Data and Factory Settings

■ Event Setup (individual channels): EVNT

*: The setup level can be changed by switching the extended menu ON/OFF. For details, see page 6-1.

Display No.	Setup Item	Setup Description	*Extended Menu		Factory Setting
			OFF	ON	
1	No.1 event setting value	-19999 to +29999	<input type="radio"/>	<input type="radio"/>	0
2	No.2 event setting value	-19999 to +29999	<input type="radio"/>	<input type="radio"/>	0
3	No.3 event setting value	-19999 to +29999	<input type="radio"/>	<input type="radio"/>	0
4	No.4 event setting value	-19999 to +29999	<input type="radio"/>	<input type="radio"/>	0
5	No.1 event type selection	0 (OFF)/1 (LOW)/2 (HIGH)		<input type="radio"/>	0 (-): (OFF)
6	No.2 event type selection	0 (OFF)/1 (LOW)/2 (HIGH)		<input type="radio"/>	0 (-): (OFF)
7	No.3 event type selection	0 (OFF)/1 (LOW)/2 (HIGH)		<input type="radio"/>	0 (-): (OFF)
8	No.4 event type selection	0 (OFF)/1 (LOW)/2 (HIGH)		<input type="radio"/>	0 (-): (OFF)
5	No.1 event output relay No.	0 to 6		<input type="radio"/>	0
6	No.2 event output relay No.	0 to 6		<input type="radio"/>	0
7	No.3 event output relay No.	0 to 6		<input type="radio"/>	0
8	No.4 event output relay No.	0 to 6		<input type="radio"/>	0
5	No.1 event recording ON/OFF	0 (OFF)/1 (ON)		<input type="radio"/>	1 (ON)
6	No.2 event recording ON/OFF	0 (OFF)/1 (ON)		<input type="radio"/>	1 (ON)
7	No.3 event recording ON/OFF	0 (OFF)/1 (ON)		<input type="radio"/>	1 (ON)
8	No.4 event recording ON/OFF	0 (OFF)/1 (ON)		<input type="radio"/>	1 (ON)
9	No.1 event differential	0 to 29999		<input type="radio"/>	0
A	No.2 event differential	0 to 29999		<input type="radio"/>	0
B	No.3 event differential	0 to 29999		<input type="radio"/>	0
C	No.4 event differential	0 to 29999		<input type="radio"/>	0

■ Chart Feed Speed Setup: SPD

Display No.	Setup Item	Setup Description	*Extended Menu		Factory Setting
			OFF	ON	
1	No.1 chart feed speed	1 to 8 (2.5/5/10/20/40/60/120/240)	<input type="radio"/>	<input type="radio"/>	4 (20)
2	No.2 chart feed speed	1 to 8 (2.5/5/10/20/40/60/120/240)		<input type="radio"/>	4 (20)

■ Date/Time Setup: CLK

Setup Item	Setup Description	*Extended Menu		Factory Setting
		OFF	ON	
Date		<input type="radio"/>	<input type="radio"/>	Close to Japan standard time
Time		<input type="radio"/>	<input type="radio"/>	Close to Japan standard time

■ Scale Setup (individual channels): SCL

Display No.	Setup Item	Setup Description	*Extended Menu		Factory Setting
			OFF	ON	
1	No.1 scale lower limit	-19999 to +29999		<input type="radio"/>	0.0
2	No.1 scale upper limit	-19999 to +29999		<input type="radio"/>	100.0
3	Scale switching method selection	0 (OFF), 1 (automatic), 2 (RSW or communications)		<input type="radio"/>	0
4	No.2 scale lower limit	-19999 to +29999		<input type="radio"/>	0.0
5	No.2 scale upper limit	-19999 to +29999		<input type="radio"/>	100.0
6	Auto-switching point	-19999 to +29999		<input type="radio"/>	0
7	Auto-switching differential	0 to 29999		<input type="radio"/>	0

■ System Setup: SYS

Display No.	Setup Item	Setup Description	*Extended Menu		Factory Setting
			OFF	ON	
1	Configuration lock	0 (OFF)/1 (ON)	<input type="radio"/>	<input type="radio"/>	0 (OFF)
2	List printing	0 (stop list printing), 1 (start specified list printing), 2 (start all list printing)	<input type="radio"/>	<input type="radio"/>	0 (stop)
3	Extended menu entry	0 (OFF)/1 (ON)	<input type="radio"/>	<input type="radio"/>	0 (OFF)
4	Recording format	1 (trend), 2 (trend + tabulation), 3 (trend + schedule demand)		<input type="radio"/>	2 (trend + tabulation)
5	Recorder ID No.	0 to 99		<input type="radio"/>	0
6	Recording time ON/OFF	0 (OFF)/1 (ON)		<input type="radio"/>	1 (ON)
7	Scale recording ON/OFF	0 (OFF)/1 (ON)		<input type="radio"/>	1 (ON)
8	Recording color selection (STD/DIN)	1 (STD)/2 (DIN)		<input type="radio"/>	1 (STD)
9	Communications access rights	1 (read)/2 (read/write)		<input type="radio"/>	2 (read/write)
A	Device address	0 to 127 (setting to "0" inhibits communications)		<input type="radio"/>	0
	Communications method	1: 4800bps, 8bits, even parity, 1 stop bit 2: 4800bps, 8bits, no parity, 2 stop bits 3: 9600bps, 8bits, even parity, 1 stop bit 4: 9600bps, 8bits, no parity, 2 stop bits		<input type="radio"/>	1
B	Schedule demand selection	0 (OFF)/1 (#1)/2 (#1, 2)/3 (#1, 2, 3)/4 (#1, 2, 3, 4)		<input type="radio"/>	0 (OFF)
C	No.1 schedule demand time	0:00 to 23:59		<input type="radio"/>	00: 00
D	No.2 schedule demand time	0:00 to 23:59		<input type="radio"/>	00: 00
E	No.3 schedule demand time	0:00 to 23:59		<input type="radio"/>	00: 00
F	No.4 schedule demand time	0:00 to 23:59		<input type="radio"/>	00: 00

■ Range Setup: RNG

Display No.	Setup Item	Setup Description	*Extended Menu		Factory Setting
			OFF	ON	
1	Recording mode	0 (OFF), 1 (display), 2 (display + recording)	<input type="radio"/>	<input type="radio"/>	2 (display + recording)
2	Range code	Selectable from all codes	<input type="radio"/>	<input type="radio"/>	05 ($\pm 5V$)
3	Input calculation type	1 (PV)/ 2 (reference channel-current channel)/ 3 (current channel-reference channel)/ 4 (fixed value-current channel)/ 5 (current channel-fixed value)/		<input type="radio"/>	1 (PV)
4	Reference channel	1 to 6		<input type="radio"/>	1
5	Burnout	0 (OFF), 1 (UP), 2 (DOWN)		<input type="radio"/>	0 (OFF)
6	Measurement range lower limit	-19999 to +29999		<input type="radio"/>	1.000
7	Measurement range upper limit	-19999 to +29999		<input type="radio"/>	5.000
8	Engineering range decimal point	0 (xxxx) to 4 (x.xxxx)		<input type="radio"/>	1 (xxxx.x)
9	Engineering range lower limit	-19999 to +29999		<input type="radio"/>	0.0
A	Engineering range upper limit	-19999 to +29999		<input type="radio"/>	100.0
B	Fixed value for deviation	-19999 to +29999		<input type="radio"/>	0
C	PV bias	-19999 to +29999		<input type="radio"/>	0
D	Engineering unit (UNIT)	6 characters		<input type="radio"/>	Blank
E	Input tag name setting (TAG)	6 characters		<input type="radio"/>	CH1 to 6 (shift to right)

6 - 3 Event Setup

■ Event Setup

The event type, event relay No., event recording ON/OFF and event differential can be set only when the extended menu is ON. These settings, however, can be changed with the extended menu OFF.

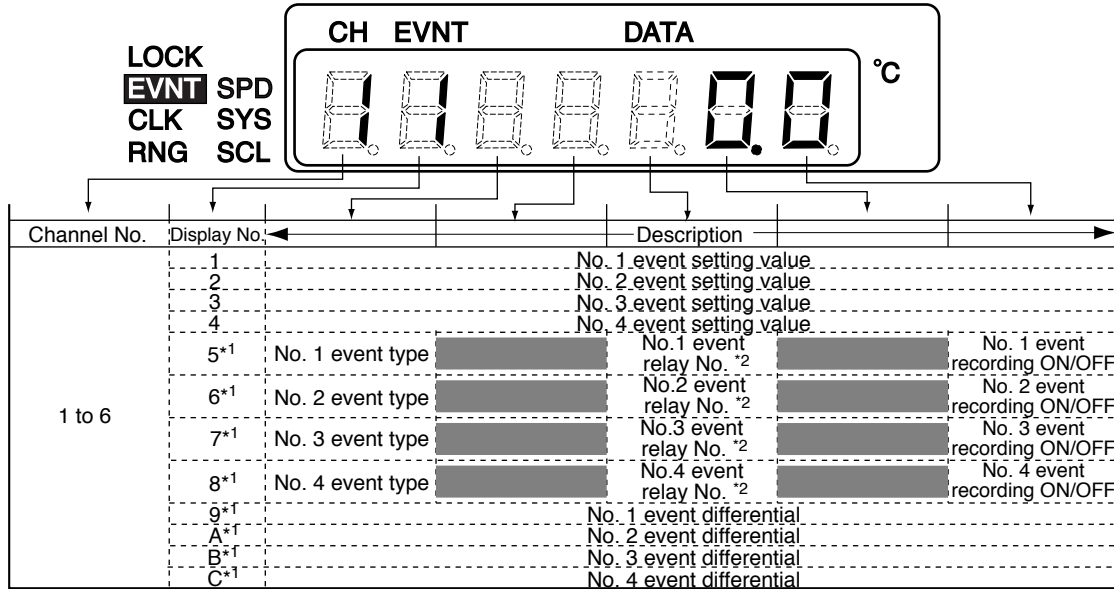

◇ Setup Details ◇

- Event setting value : “-19999 to +29999” (U)
- Event type : “----” no event
“H” upper limit
“L” lower limit
- Event relay No. : “0” relay output OFF
“1 to 6” (Each number corresponds to respective event relay No.)
- Event recording ON/OFF : “0” event recording OFF
“1” event recording ON
- Event differential : “0 to 29999” (U)

Note

- *1: This is displayed when the extended menu is ON.
Event setting values are not displayed when the event type is set to “—” (no event).
- *2: Event setting values that do not support the event relay optional function are not displayed.

■ Description of Event Setup Items

● Event type and differential

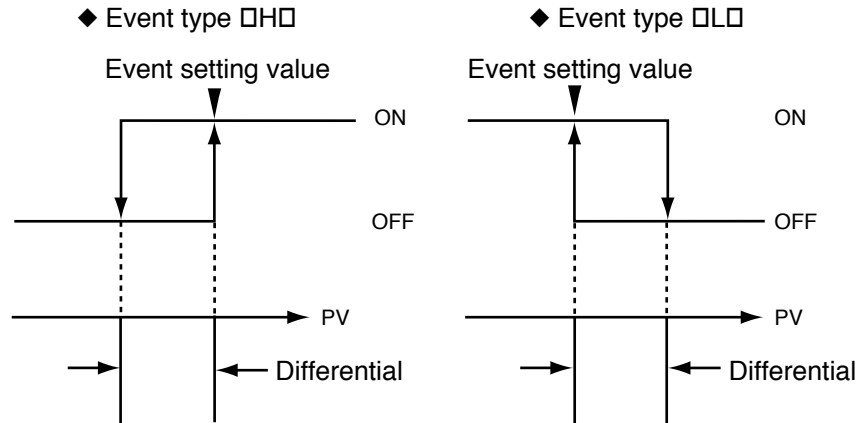

● Event relay No.

Output to all relays is disabled when the event relay No. is set to “0”.

Four event settings can be set to each channel, which means that a total of 24 event settings can be set as there are six input channels. Also, the same event relay No. can be set in two or more event settings. In this case, the relay that is used in duplicate is OR-ed and cannot be AND-ed.

● Event recording ON/OFF

When event recording is set to OFF, neither event occurrence nor restoration are recorded.

● Event buffer

Up to 24 events including occurrences and restorations can be buffered (stored in memory). Events exceeding this figure are not buffered. If events occur or are restored beyond this figure, a “*” mark is inserted between the channel No. and h:min in the list print of the 24th buffered event.

● Relay excitation direction and contact

When an event occurs, the relay is excited according to the specified relay output setting. The contact is transfer contact output (both NO and NC contacts are output by SPDT output).

● Relay contact rating

240Vac 1A (non-inductive load), 30Vdc 1A (non-inductive load)

Minimum load: 5Vdc 10mA, Electrical life: 100,000 operation (resistive load)

● Event monitoring cycle

30s (same as input scan cycle)

6 - 4 Chart Feed Speed Setup

■ Chart Feed Speed Setup

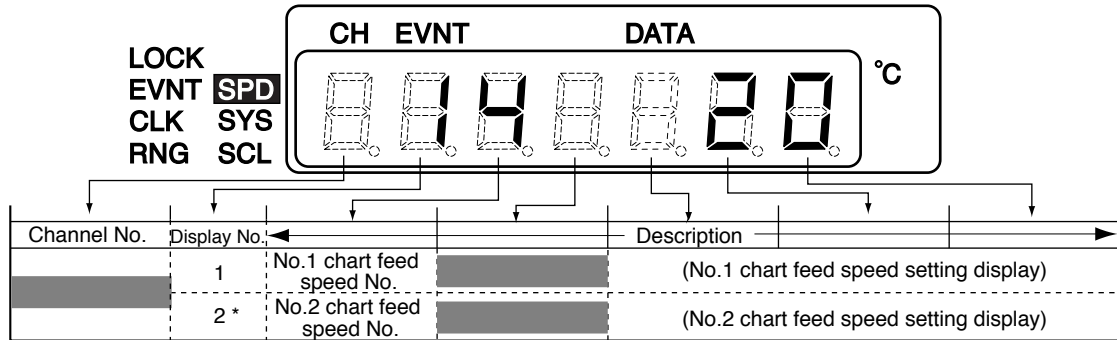

📖 Note

Items marked by * are displayed when the extended menu is set to ON.
 Characters are not printed when the chart feed speed is 240mm/h.

◇ Setup Details ◇

Chart feed speed No. : 1 to 8

Chart Feed Speed No.	Chart Feed Speed Setting Display (mm/h)	Tabulation Printing Cycle (trend + tabulation)
1	2.5	12h
2	5	12h
3	10	4h
4	20	2h
5	40	1h
6	60	1h
7	120	1h
8	240	Tabulation printing OFF

■ Description of Chart Feed Speed Setup Items

● Chart feed speed and printing cycle

The time standard for the tabulation printing cycle is “00:00”.

If, for example, the chart feed speed is 20mm/h, then the tabulation time becomes 00:00, 02:00 and so forth up to 22:00.

To carry out tabulation printing at a specific time, select “trend + schedule demand” printing as the recording format.

● Chart feed speed and date printing

Chart feed speed and date are printed alternately.



Note

Chart Feed Speed and Character Size

Characters are printed as a 5-dot x 7-dot matrix. Their height varies as follows according to the chart feed speed. When the chart feed speed is 120mm/h, characters become longer and are difficult to distinguish. However, they become easier to distinguish if they are viewed at an angle from the bottom of the chart.



Handling Precautions

Characters are not printed when the chart feed speed is 240mm/h.

Character sizes

Chart Feed Speed (mm/h)	2.5, 5, 10, 20, 40	60	120	240
Item				
Character Height (mm)	2.5	3.5	6.5	Printing OFF
Character Width (mm)	2.0	2.0	2.0	
Vertical Pitch (mm)	3.33	5.0	8.0	

6 - 5 Date/Time Setup

■ Date/Time Setup

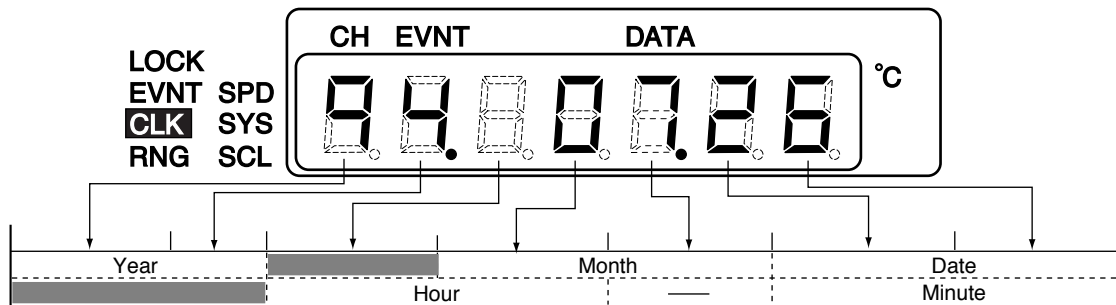

! Handling Precautions

If the date and time setup is in error, all data blinks when you press the **ENT** key. If this happens, press any key to redisplay the data entry display.

The number of seconds in the time setup is reset (so that counting starts from "00") when you press the **ENT** key, only when the numerical values for the time setup are changed. If you press the **ENT** key without making any changes to the numerical values for the time setup, the date setup display will be redisplayed, and the number of seconds will not be reset.

◇ Setup Details ◇

Year : Lower two digits of Western calendar year

Month : "01 to 12" January to December

Day : "01 to 31" 1st to 31st

Hour : "00 to 23" 0am to 11pm

Minute : "00 to 59" 0 to 59min

📖 Note

- Clock accuracy is about ± 50 ppm or about 130s/month under standard conditions.
- The SRF106 automatically adjusts for leap years until 2099.



6 - 6 System Setup

■ System Setup

By system setup you set the basic items for operating this recorder.

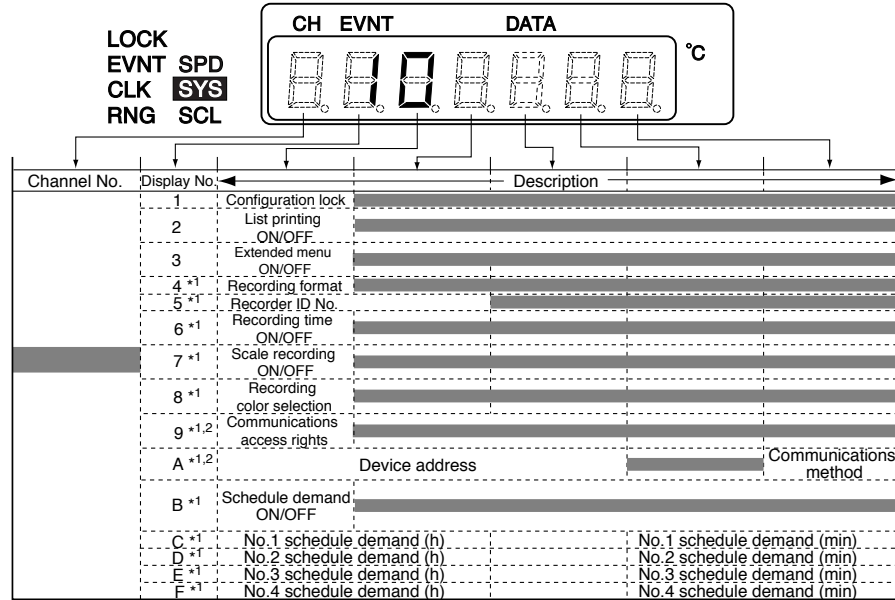

Note

- *1: This is displayed when the extended menu is ON.
- *2: These are not displayed on models that do not support the communications (optional) function.

◇ Setup Details ◇

- Configuration lock : "0" lock OFF
"1" lock ON
- List printing start/stop : "0" stop printing of lists
"1" start printing of specified lists
"2" start printing of all lists
- Extended menu ON/OFF : "0" OFF
"1" ON (enabled)
- Recording format : "1" trend
"2" trend + tabulation
"3" trend + schedule demand
- Recorder ID No. : "0 to 99" ID No. is not printed when set to "0"
- Time recording ON/OFF : "0" OFF (time is not recorded)
"1" ON (time is recorded)
- Scale recording ON/OFF : "0" OFF (scale is not recorded)
"1" ON (scale is recorded)
- Recording color selection : "1" STD (purple, red, green, blue, brown, black)
"2" DIN (purple, red, black, green, blue, brown)
- Communications access rights : "1" read only
"2" read/write
- Device address : "0 to 127" communications is inhibited when set to "0".
- Communications method : "1" 4800bps, 8bits, even parity, 1 stop bit
"2" 4800bps, 8bits, no parity, 2 stop bits
"3" 9600bps, 8bits, even parity, 1 stop bit
"4" 9600bps, 8bits, no parity, 2 stop bits
- Schedule demand ON/OFF : "0" (Printing is not carried out at any preset time.)
"1" (Tabulation printing is carried out at the No.1 time.)
"2" (Tabulation printing is carried out at the No.1 and No.2 times.)
"3" (Tabulation printing is carried out at the No.1, No.2 and No.3 times.)
"4" (Tabulation printing is carried out at all No.1, No.2, No.3 and No.4 times.)
- Schedule demand h:min setting : "0 to 23" (h)
"0 to 59" (min)

■ Description of System Setup Items

● Details of specified list printing

- Year:month:day/h:min/recording format/chart feed speed/recorder ID number
- Channel number/range type/recording scale/unit
- Event setup (setting value, type)

All details are printed in all lists.

● How to use the recorder ID No.

When you are using two or more SRF106s, you can print individual recorder ID Nos. when printing is started to distinguish which recorder is being used to record on the chart.

● Time recording OFF

When time recording is set to OFF, no date/time information is printed on the chart. When importance is placed on knowing actual time, set time recording to ON (factory setting).

● Recording color selection

You can select from two types of color patterns. The DIN color pattern is provided mainly for use in Europe.

● Schedule demand

When “trend + schedule demand” recording is selected as the recording format, and display Nos.B to F in the setup procedure are set, tabulation can be printed at the necessary times up to four times per day.

If schedule demand is set, and the SRF106 is set to a recording state, tabulation printing will be carried out without any omissions at preset times, for example, when recording processes that require reporting at fixed times, or when recording process values at the change of operator shifts.

Schedule demand cannot be used in conjunction with the “trend + tabulation” format.

❗ Handling Precautions

If the preset time is shorter than the fixed period of time (time interval) indicated in the table below, subsequent time settings are sometimes ignored, and recording is not performed. This is because the next schedule demand setting is not executed during the previous schedule demand printing. When the next preset time is reached during tabulation printing, that setting is ignored. Set schedule demand

printing making sure that the time intervals for each chart feed speed in the table below are provided between set schedule demand printings.

Chart Feed Speed (mm/h)	Time Interval
2.5	241min minimum
5	122min minimum
10	62min minimum
20	32min minimum
40	17min minimum
60	15min minimum
120	12min minimum

6 - 7 Range Setup

Range Setup

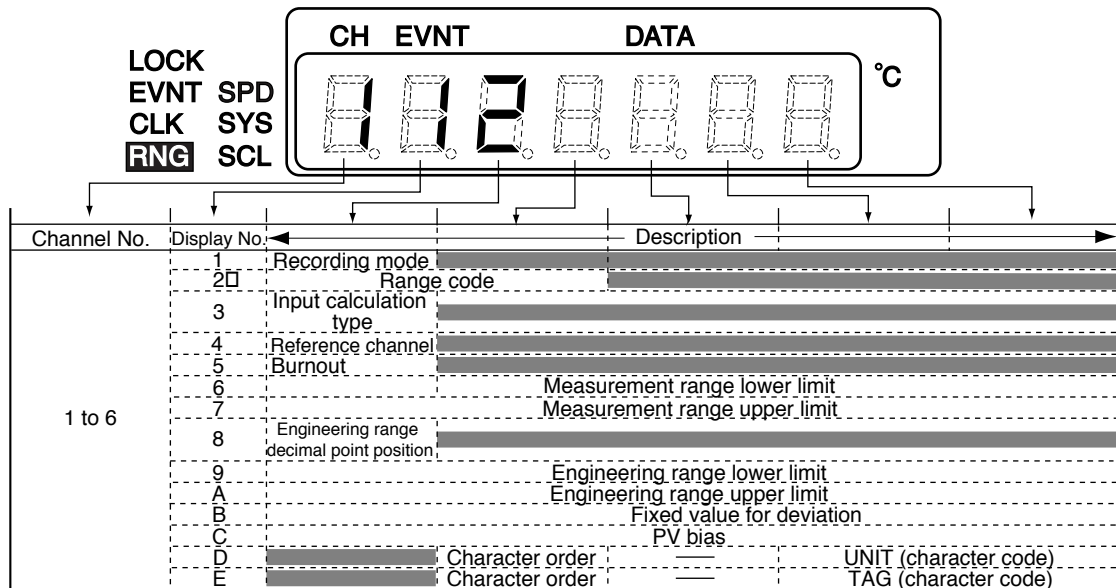

Note

Some items are not displayed depending on the setup details such as range code or input calculation type.

◇ Setup Details ◇

- Recording mode : “0” display/recording OFF
 “1” display only
 “2” display + recording
- Range code : See 6-9 Range Code Table (page 6-20)
- Input calculation type : “1 to 5” (See page 6-13)
- Reference channel : “1” to “6”
- Burnout : “0” OFF
 “1” UP (up scale)
 “2” DOWN (down scale)
- Measurement range lower/upper limit : “-19999 to +29999” (U)
- Engineering range decimal point : “0” XXXXX
 “1” XXXX.X
 “2” XXX.XX
 “3” XX.XXX
 “4” X.XXXX
- Engineering range upper/lower limits : “-19999 to +29999” (U)
- Fixed value for deviation : “-19999 to +29999” (U)
- PV bias : “-19999 to +29999” (U)
- Character order : “1 to 6” 1st to 6th character
- UNIT (Engineering unit) : See 6-10 Character Code Table (page 6-21)
 (Set by character code.)
- TAG (input tag name) : See 6-10 Character Code Table (page 6-21)
 (Set by character code.)

■ Description of Range Setup Items

● Recording mode and operation

Recording Mode	Display	Recording	Event	Communications
"0" display/recording OFF	X	X	X	-32767 is returned
"1" display only	Operable	X	Operable	Operable
"2" display/recording ON	Operable	Operable	Operable	Operable

● Range code selection

The SRF106 supports full multi-input. Merely selecting the range type here fixes the range code.

● PV bias

"PV bias" refers to the PV offset value. This value is used in the following instances:

- On instrumentation incorporating a controller and a recorder, enter the PV bias when double-element RTDs or thermocouple inputs are used in parallel. PV bias functions to match the PV value indicated on the controller and the PV on the recorder.
- Enter the PV bias when the sensor is impaired or when measurement values are deviating. PV bias functions to compensate measurement values.

● Input calculation

With this function, the reference channel, current channel, PV bias value and fixed value for deviation are used for calculating the difference, and the calculation result is displayed and recorded as the current channel data.

[Calculation Example]

The data obtained by adding the PV bias value to the input value for both the current channel and the reference channel is used to calculate the difference.

Calculation equation

$$\text{CH1}=(5.000+1.000)-(4.000+2.000)=0.000$$

$$\text{CH2}=(4.000+2.000)-3.000=3.000$$

	Channel 1	Channel 2
Input value	5.000	4.000
Input calculation type	CH1-CH2	CH2-fixed value
Fixed value for deviation	—	3.000
PV bias	1.000	2.000
Calculation result (PV value)	0.000	3.000

Calculation equation

$$\text{CH1}=(5.000+1.000)-(3.000+2.000)=1.000$$

$$\text{CH2}=(3.000+2.000)-(5.000+1.000)=-1.000$$

	Channel 1	Channel 2
Input value	5.000	3.000
Input calculation type	CH1-CH2	CH2-CH1
Fixed value for deviation	—	—
PV bias	1.000	2.000
Calculation result (PV value)	1.000	-1.000

- “1” : PV value
- “2” : {(reference channel input value)+(reference channel bias value)}-{(current channel input value)+(current channel bias value)}
- “3” : {(current channel input value)+(current channel bias value)}-{(reference channel input value)+(reference channel bias value)}
- “4” : (fixed value)-{(current channel input value)+(current channel bias value)}
- “5” : {(current channel input value)+(current channel bias value)}-(fixed value)

● **Input calculation type and calculation result**

The calculation result is used for display and recording as the current channel data, and for processing events.

● **Position of engineering range decimal point and engineering range upper/lower limit values**

These settings determine the display resolution of the measurement range. The resolution of trend recording is fixed to 0.1%F.S. regardless of these settings.

● **Reverse scaling**

You can reverse scaling of the engineering range by reversing the numerical values for the upper and lower limit values.

● **Measurement range and engineering range setup**

These ranges can be set only when the input range code is set to 00 to 06.

(When other range codes are set, the setup mode is not migrated to.)

PV is calculated by the following formula:

$$(PV) = \frac{(\text{engineering range upper limit value}) - (\text{engineering range lower limit value})}{(\text{measurement range upper limit value}) - (\text{measurement range lower limit value})} \times \{(\text{input value}) - (\text{measurement range lower limit value})\} + (\text{engineering range lower limit value}) + (\text{PV bias})$$

The measurement range is assigned to the range of the DC voltage that is to be actually used.

[Setup Example 1]

Item	Input Value	Description
Range code setting	5	-5 to +5V
Measurement range upper value	5.000	
Measurement range lower value	1.000	When 0.0 to 2500.0kPa is assigned to the voltage input value of 1 to 5V.
Engineering range upper value	2500.0	
Engineering range lower value	0.0	
Engineering unit	kPa	

Indicated PV value when 2V is input = 625kPa

[Setup Example 2]

Item	Input Value	Description
Range code setting	5	-5 to +5V
Measurement range upper value	3.200	
Measurement range lower value	1.200	When 0.0 to 2500.0kPa is assigned to the voltage input value of 1.2 to 3.2V.
Engineering range upper value	2500.0	
Engineering range lower value	0.0	
PV bias	-1000.0	
Engineering unit	kPa	

Indicated PV value when 2V is input = 0kPa

6 - 8 Scale Setup

■ Scale Setup

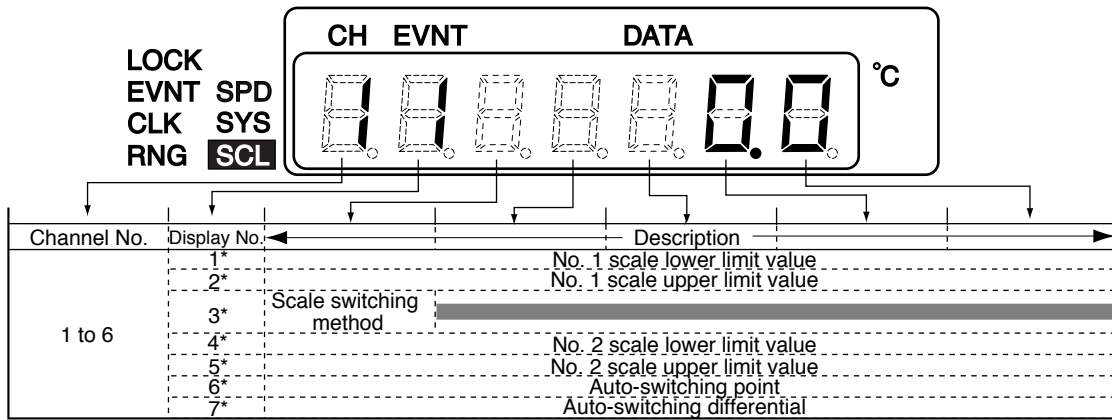

! Handling Precautions

Items marked by * are displayed when the extended menu is set to ON.

Scale setup items are skipped and not displayed when the extended menu is set to OFF.

Some items are not displayed depending on their setting.

◇ Setup Details ◇

- Scale upper/lower limits : “-19999 to +29999” (U)
- Scale switching method : “0” switching OFF
“1” auto-switching
“2” switching by external switch input/communications
- Auto-switching point : “-19999 to +29999” (U)
- Auto-switching differential : “0 to +29999” (U)

■ Description of Scale Setup Items

● Reverse scaling

You can reverse scaling of the No.1 and No.2 scales by reversing the numerical values for the upper and lower limit values.

● Auto-switching differential

The differential is set to provide a degree of margin so that the recording scale is not immediately restored to its original scale when auto-switching is set.

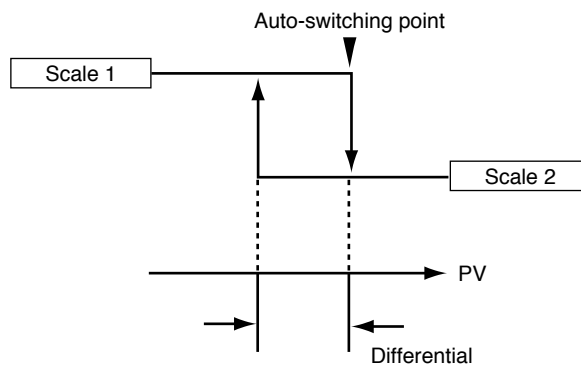

● Minimum scaling range

Trend recording becomes stepped if scaling is set too narrow.

The resolution of trend recording in a 100mm recording width is 1/1000. Carry out scaling in such a way that this, or a higher resolution, can be obtained referring to the resolution item in the specifications.

● Scale setup

The recording scale lower and upper limit values are set as the chart 0% and 100% positions. For example, the range is -200.0 to +1370.0°C (input range code: 23) in the case of a K thermocouple. However, to set the left side (0% position) of the chart as “0.0°C” and the right side (100% position) of the chart as “1000.0°C” when carrying out trend recording on the chart, set the scale lower limit value to “0.0” and the upper limit value to “1000.0”.

As the scale setup range is -19999 to +29999, this can be used to record specific zones. For example, in the above example, to write the trend of a K thermocouple on the right half of the chart, set the scale lower limit value to “-1000.0” and the upper limit value to “1000.0”.

Example: K thermocouple range code: 23 (-200.0 to +1370.0°C)

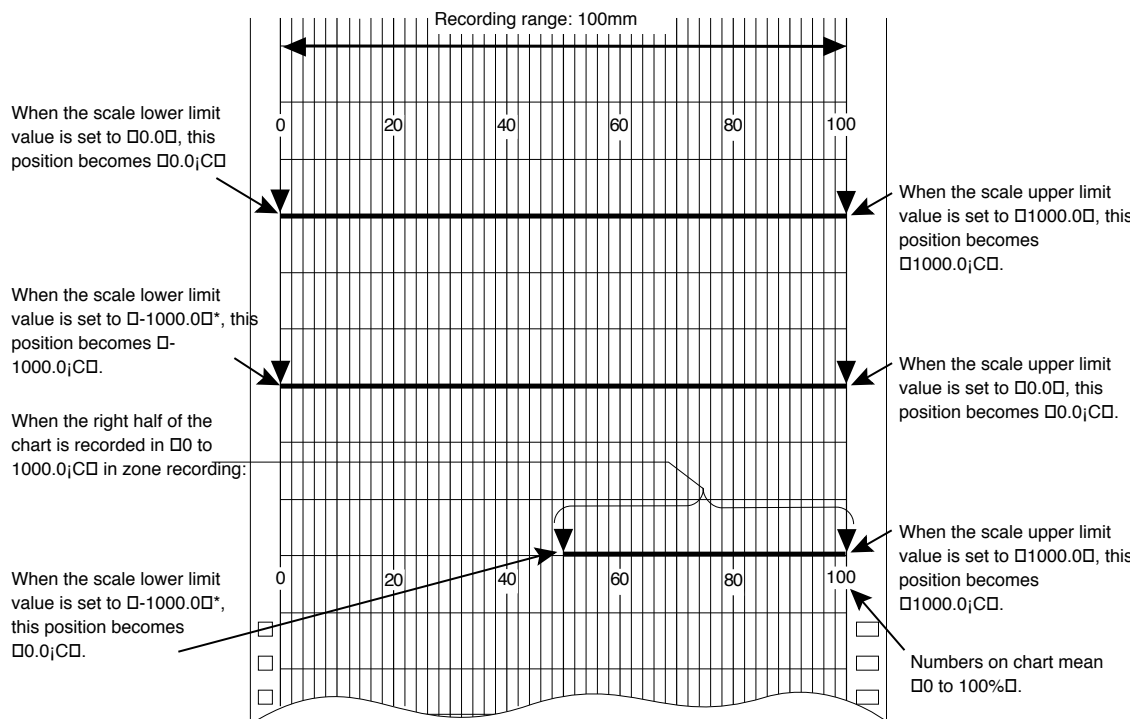

*:□In the linear scale range, the decimal point becomes □
□ the value set in the range setup item.

! Handling Precautions

The scale setup range is -1999.9 to +2999.9

■ Making and Mounting an Analog Scale

An analog scale can be mounted at the top of the chart cassette on the SRF106. Make this analog scale out of OHP sheet or transparent resin of maximum thickness 0.9mm referring to the dimensions indicated on the following page. If you enlarge the drawings on the following page to A4 size, the resulting copy will be roughly the actual size.

Insert both ends of the scale into the grooves on the chart guide.

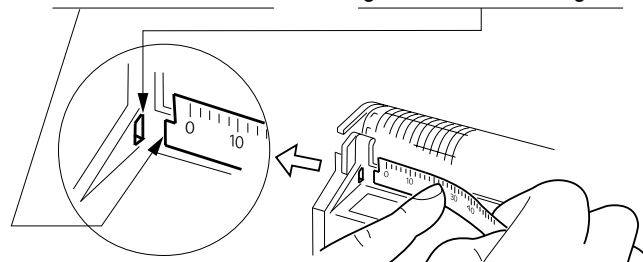

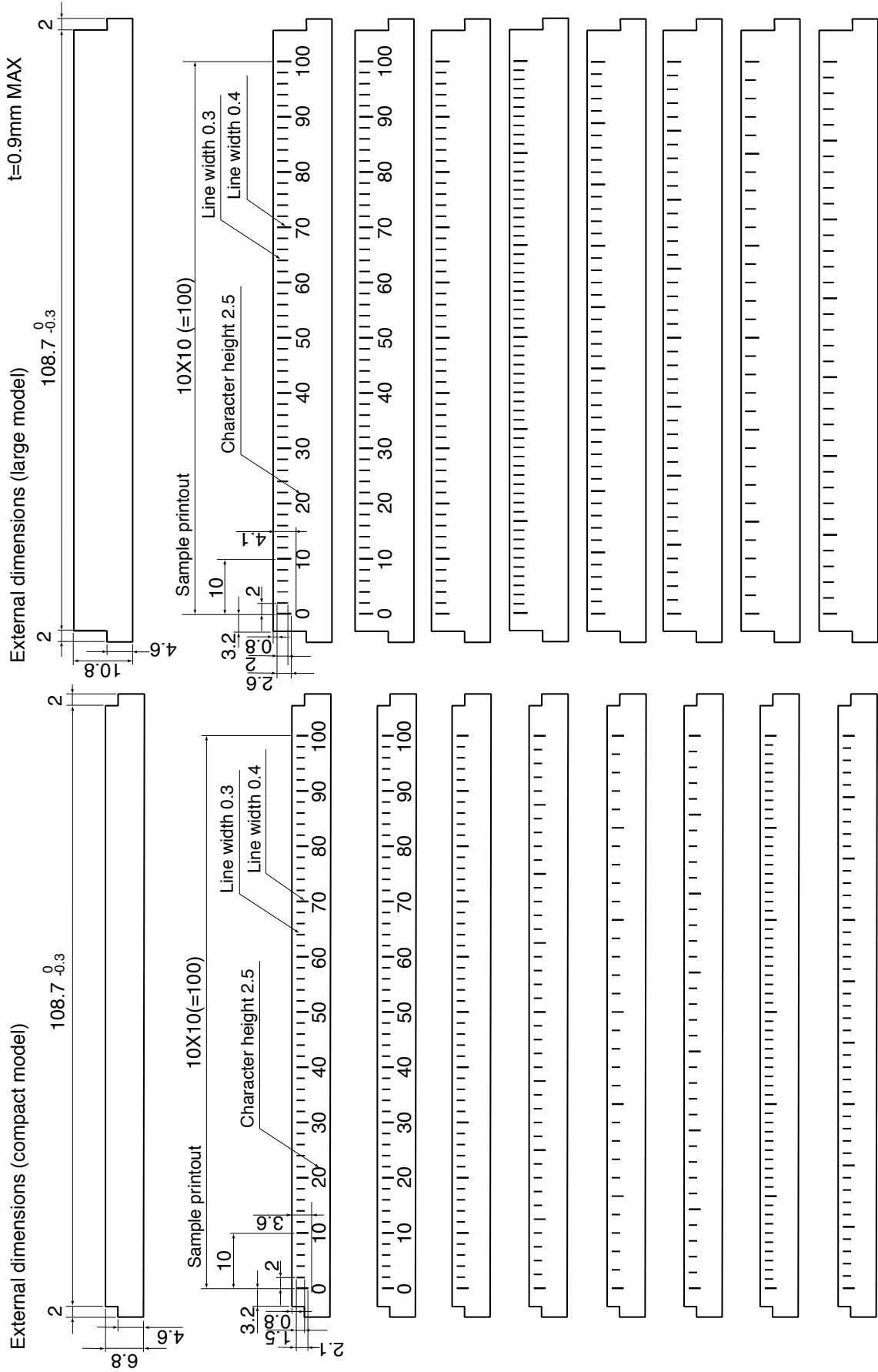

6 - 9 Range Code Table

Input			Range		
Type	Symbol	Code	mV/V Input	mV/V Display Range	
DC voltage	mV	00	±20mV	-19999 to +29999	
		01	±40mV	-19999 to +29999	
		02	±60mV	-19999 to +29999	
		03	±200mV	-19999 to +29999	
		V	04	±2V	-19999 to +29999
			05	±5V	-19999 to +29999
	06		0 to 10V	-19999 to +29999	
	mV	10	±20mV	±20.00mV	
		11	±40mV	±40.00mV	
		12	±60mV	±60.00mV	
		13	±200mV	±200.0mV	
		V	14	±2V	±2.000V
			15	±5V	±5.000V
	16		0 to 10V	0 to 10.000V	
	Type	Symbol	Code	°C Range	
	Thermocouple	R	20	0.0 to 1760.0°C	
S		21	0.0 to 1760.0°C		
B		22	0.0 to 1820.0°C		
K		23	-200.0 to +1370.0°C		
E		24	-200.0 to +800.0°C		
J		25	-200.0 to +1100.0°C		
T		26	-200.0 to +400.0°C		
Nicrosil-Nisil		27	0.0 to 1300.0°C		
WRe0-26		28	0.0 to 2320.0°C		
WRe5-26		29	0.0 to 2320.0°C		
PR40-20		30	0.0 to 1880.0°C		
PLII		31	0.0 to 1290.0°C		
Ni-Ni•Mo		32	0.0 to 1200.0°C		
Kp-Au7Fe	33	0.0 to 300.0°C			
Resistance temperature detector (RTD)	Pt100	40	-200.0 to +650.0°C		
	JPt100	41	-200.0 to +550.0°C		
Type	Symbol	Code	°F Range		
Thermocouple	R	50	32 to 3200°F		
	S	51	32 to 3200°F		
	B	52	32 to 3308°F		
	K	53	-328 to +2498°F		
	E	54	-328 to +1472°F		
	J	55	-328 to +2012°F		
	T	56	-328 to +752°F		
	Nicrosil-Nisil	57	32 to 2372°F		
	WRe0-26	58	32 to 4208°F		
	WRe5-26	59	32 to 4208°F		
	PR40-20	60	32 to 3416°F		
	PLII	61	32 to 2354°F		
	Ni-Ni•Mo	62	32 to 2192°F		
Resistance temperature detector (RTD)	Pt100	70	-328.0 to +1202.0°F		
	JPt100	71	-328.0 to +1022.0°F		

6 - 10 Character Code Table

Upper Bits Lower Bits	2	3	4	5	6	7	8
0	(blank)	0	@	P	`	p	³
1	!	1	A	Q	a	q	°
2	“	2	B	R	b	r	。
3	#	3	C	S	c	s	•
4	\$	4	D	T	d	t	
5	%	5	E	U	e	u	
6	&	6	F	V	f	v	
7	’	7	G	W	g	w	
8	(8	H	X	h	x	
9)	9	I	Y	i	y	
A	*	:	J	Z	j	z	
B	+	;	K	[k	Ω	
C	,	<	L	¥	l		
D	-	=	M]	m	μ	
E	.	>	N	^	n	²	
F	/	?	O	_	o	₂	

Setup Example: kPa

Step	Engineering Unit	Character Code
1	k	6B
2	P	50
3	a	61
4	(blank)	20
5	(blank)	20
6	(blank)	20

Setup Example: TIRC-1

Step	Tag	Character Code
1	T	54
2	I	49
3	R	52
4	C	43
5	-	2D
6	1	31

6 - 11 External Switch Inputs (Optional Functions)

The following functions are set to external switch inputs before the SRF106 is shipped from the factory. These functions cannot be changed on the SRF106 alone. You can, however, set any of the following functions using the Smart Loader Package (SLP-F10) for the SRF106:

■ Default Function Assignments

No.1 recording start/stop	Recording is stopped by OPEN → CLOSE. Recording is started by CLOSE → OPEN.
No.2 demand printing	Demand printing is started by OPEN → CLOSE.
No.3 chart feed	Chart is fed 40mm by OPEN → CLOSE.
No.4 print message 1	Printing (MSG1) is started by OPEN → CLOSE.

■ List of Functions Settable using the Smart Loader Package (SLP-F10)

- ◇ Recording start/stop Recording is stopped by OPEN → CLOSE.
Recording is started by CLOSE → OPEN.
- ◇ Demand printing Demand printing is started by OPEN → CLOSE.
- ◇ Chart feed Chart is fed 40mm by OPEN → CLOSE.
- ◇ Print message 1 Printing (MSG1) is started by OPEN → CLOSE.
- ◇ Print message 2 Printing (MSG2) is started by OPEN → CLOSE.
- ◇ Print message 3 Printing (MSG3) is started by OPEN → CLOSE.
- ◇ Print message 4 Printing (MSG4) is started by OPEN → CLOSE.
- ◇ Chart feed speed/scale switching
#1 scale and #1 chart feed speed by CLOSE → OPEN
#2 scale and #2 chart feed speed by OPEN → CLOSE

■ Detecting External Switch Input

Hold external switch input ON/OFF states at 500ms or more.

! Handling Precautions

To prevent malfunction caused by noise, changes in state are not detected unless they last for 500ms or more.

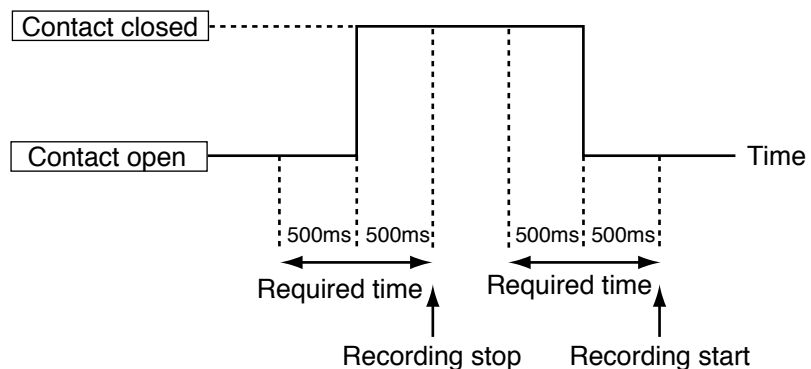

6 - 12 Printout Messages

Message printing functions when the SRF106 supports external switch inputs (optional function), and is started by external switch input.

By message printing, the time (h:min) and message (up to six characters) are printed.

To change the details set to a message, you will need the Smart Loader Package (SLP-F10). The following shows factory settings:

■ Printout Message Defaults

Message 1	MSG1
Message 2	MSG2
Message 3	MSG3
Message 4	MSG4

■ Characters That Can be Set by the Smart Loader Package (SLP-F10)

Select six characters from the 6-10 Character Code Table (page 6-21).

6 - 13 About Digital Printing Priority

Digital printing on the SRF106 is subject to several restrictions to ensure that trend recording is not interrupted. This is called “printing control.” The following briefly describes printing control:

■ Printing Control during a Print Conflict

Digital printing is categorized into the following four groups. In principle, printing is carried out in the order in which it occurs within each group. However, start of printing is sometimes suppressed or printing is canceled midway according to the type of printing. If printing of one group conflicts with printing of another, either printing of one of the groups is suppressed or one of the groups is printed over the other. The following describes these restrictions.

Print Group	Print Item	Restrictions
A	Event	
B	Initial printing	
	Demand printing	
	Message	
	Schedule demand	Printing is canceled when demand printing occurs (even during print standby).
	Tabulation	
	Scale	Printing of this item is not started up when other printing is currently in progress or standing by.
	Channel No.	Printing of this item is not started up when other printing is currently in progress or standing by.
C	Chart feed speed selection	The current group is printed overlapping other groups.
D	Scale selection	Printing is canceled when a conflict with group A occurs. However, note that the change marker is recorded.

! Handling Precautions

- When printing of group A or group D conflicts with printing of the scale upper limit or the scale tag/unit, printing of the scale upper limit or the scale tag/unit is canceled. (The change marker, however, is recorded for group D.)
- When two or more schedule demands are registered, and schedule demand printing is currently in progress or standing by, start of the remaining schedule demands is not accepted even if the startup time is reached.

■ Simultaneous Printing Control

When demand printing and message printing or schedule demand printing and message printing continuously stand by to be printed, a message is printed on the h:min line of demand printing (manual demand and schedule demand). This, however, does not apply in the following instances:

- When message printing is started during demand printing (or, vice versa)
- When demand printing (or, message printing) is started anew in a simultaneous printing state

Chapter7. SETUP EXAMPLES

7 - 1 Setup Examples 1

This chapter describes how to set the following setting values to your SRF106 using actual examples:

Applicable models: All SRF106 models

Setup conditions:

- Input type and recording scale
Set K(CA) as the input type to all channels 1 to 6, and the recording scale to 0.0 to 800.0°C.
- Input burnout
Set all channels 1 to 6 to UP.
(By this system, the input is forcibly brought to the upper limit (UP) when a thermocouple burns out.)
- Chart feed speed
20mm/h
- Recording format
Trend + tabulation
(In this recording method, analog recording is mixed with digital printing.)

■ Setup Items

See the table below.

- Columns containing numbers or letters are items that need to be set.
- Blank columns are items that need not be set. (The setup item itself is sometimes not displayed.)
- Some setups may be left at their defaults.

Range Setup (for each channel)

Display No.	Setup Item	Channel					
		1	2	3	4	5	6
1	Recording mode selection	2	2	2	2	2	2
2	Range code	23	23	23	23	23	23
3	Input calculation type	1	1	1	1	1	1
4	Reference channel						
5	Burnout selection	1	1	1	1	1	1
6	Measurement range lower limit						
7	Measurement range upper limit						
8	Engineering range decimal point						
9	Engineering range lower limit						
A	Engineering range upper limit						
B	Fixed value for deviation						
C	PV bias	0	0	0	0	0	0
D	Engineering unit setting (UNIT)						

Chapter 7. SETUP EXAMPLES

Display No.	Setup Item	Channel					
		1	2	3	4	5	6
E	Input tag name setting (TAG)	20 (blank)	20 (blank)	20 (blank)	20 (blank)	20 (blank)	20 (blank)
		20 (blank)	20 (blank)	20 (blank)	20 (blank)	20 (blank)	20 (blank)
		20 (blank)	20 (blank)	20 (blank)	20 (blank)	20 (blank)	20 (blank)
		43 (C)	43 (C)	43 (C)	43 (C)	43 (C)	43 (C)
		48 (H)	48 (H)	48 (H)	48 (H)	48 (H)	48 (H)
		31 (1)	32 (2)	33 (3)	34 (4)	35 (5)	36 (6)

Scale Setup

Display No.	Setup Item	Channel					
		1	2	3	4	5	6
1	No.1 scale lower limit	0.0	0.0	0.0	0.0	0.0	0.0
2	No.1 scale upper limit	800.0	800.0	800.0	800.0	800.0	800.0
3	Scale switching method selection	0	0	0	0	0	0
4	No.2 scale lower limit						
5	No.2 scale upper limit						
6	Auto-switching point						
7	Auto-switching differential						

Event Setup

Display No.	Setup Item	Channel					
		1	2	3	4	5	6
1	No.1 event setting value						
2	No.2 event setting value						
3	No.3 event setting value						
4	No.4 event setting value						
5	No.1 event type selection						
6	No.2 event type selection						
7	No.3 event type selection						
8	No.4 event type selection						
5	No.1 event output relay No.						
6	No.2 event output relay No.						
7	No.3 event output relay No.						
8	No.4 event output relay No.						
5	No.1 event recording ON/OFF						
6	No.2 event recording ON/OFF						
7	No.3 event recording ON/OFF						
8	No.4 event recording ON/OFF						
9	No.1 event differential						
A	No.2 event differential						
B	No.3 event differential						
C	No.4 event differential						

System Setup (common settings)

Display No.	Setup Item	User Setup Field
1	Configuration lock	0
2	List printing	
3	Extended menu entry	1
4	Recording format selection	2
5	Recorder ID No.	
6	Recording time ON/OFF	1
7	Scale recording ON/OFF	1
8	Recording color selection (STD/DIN)	1
9	Communications access rights selection	
A	Device address	
	Communications method	
B	Schedule demand ON/OFF	
C	No.1 schedule demand time	
D	No.2 schedule demand time	
E	No.3 schedule demand time	
F	No.4 schedule demand time	

Chart Feed Speed Setup

Display No.	Setup Item	User Setup Field
1	No.1 chart feed speed No.	4
2	No.2 chart feed speed No.	

Date/Time Setup

Setup Item	User Setup Field
Date	
Time (h:min)	

■ Procedure

- [1] Set the extended menu to ON so that you can configure your SRF106 in more detail (e.g. input type).
- [2] Set the input type and burnout.
- [3] Set the recording scale.
- [4] Set the extended menu to OFF.
- [5] Return to the basic display mode.

■ Actual Setup

- [1] Set the extended menu to ON so that you can configure your SRF106 in more detail (e.g. input type).

- 1. Press the **SET** key several times until the SYS LED lights.

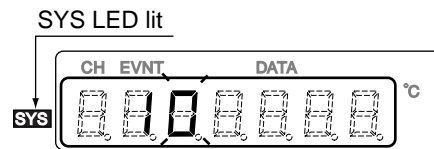

- 2. Press the **ENT** key twice to advance to display No.3.

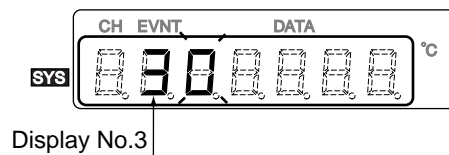

- 3. Press the **▲** key to change the extended menu setting from "0" (OFF) to "1" (ON).

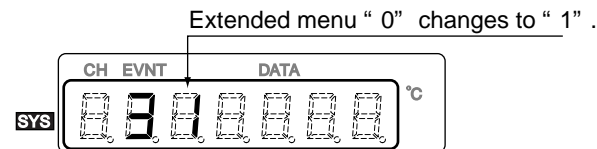

- 4. Press the **ENT** key.

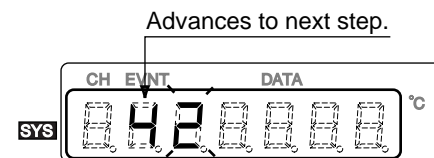

- [2] Set the input type and burnout.

- 1. Press the **SET** key until the RNG LED lights. At first, channel No.1 blinks.

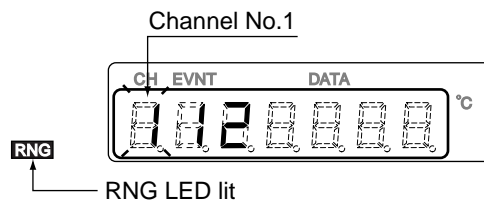

◆◆ To set range code “23” and burnout “1” of channel No.1 ◆◆

2. Press the **ENT** key to advance to display No.2.

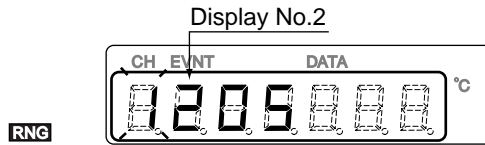

3. Press the **▶** key to shift to the 10's digit of the range code.

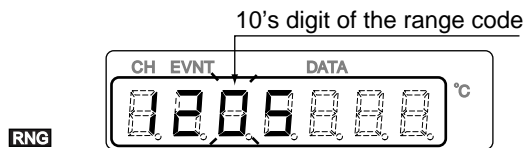

4. Press the **▲** key to change the 10's digit to “2”. (If the current setting is “0”, press the **▲** key twice to change it to “2”.)

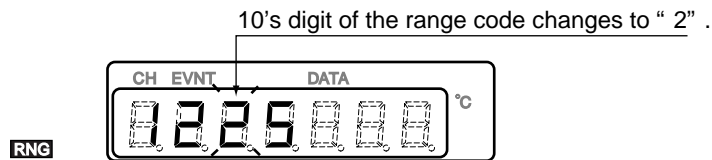

5. Press the **▶** key to shift to the 1's digit.



6. Press the **▲** key to change the 1's digit to “3”. (If the current setting is “2”, press the **▲** key eight times to change it to “3”.)

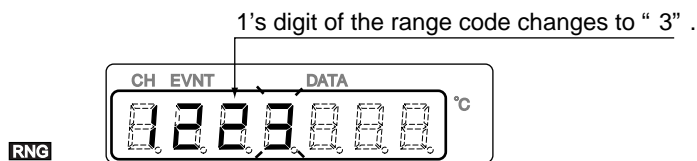

7. Press the **ENT** key several times to advance to display No.5.

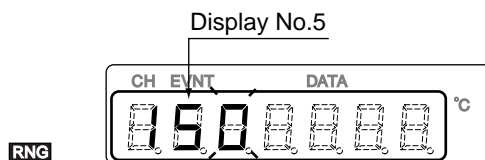

8. Press the **▲** key to change the burnout setting value from “0” (OFF) to “1” (UP).

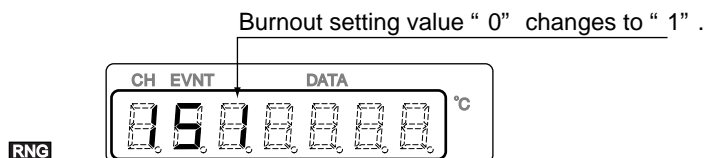

◆◆ To set range code “23” and burnout “1” of channel No.2 ◆◆

9. Press the **ENT** key several times to set the channel No. to “2”.
 (You can also advance to channel No.2 by pressing the **▶** key several times, moving to the channel setting value and then pressing the **▲** key.)

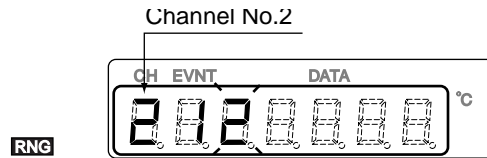

10. Press the **ENT** key to advance to display No.2.

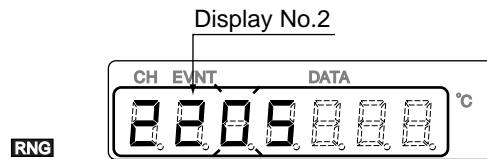

11. Press the **▲** key to change the 10’s digit to “2”. (If the current setting is “0”, press the **▲** key twice to change it to “2”.)

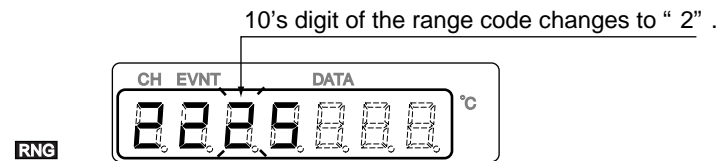

12. Press the **▶** key to shift to the 1’s digit.



13. Press the **▲** key to change the 1’s digit to “3”. (If the current setting is “2”, press the **▲** key eight times to change it to “3”.)

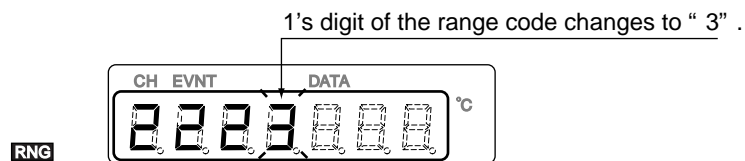

14. Press the **ENT** key several times to advance to display No.5.



15. Press the **▲** key to change the burnout setting value from “0” (OFF) to “1” (UP).



◆◆ To set range code “23” and burnout “1” to channel Nos.3 to 6 ◆◆

Set steps 9. to 15. in the previous example while changing the channel No.

16. When you have finished making the burnout setting for the last channel No.6, be sure to press the **ENT** key. (If you press the **SET** key or **DISP** key without pressing the **ENT** key, and shift to another setup item or display another item, the last setup will not be stored to memory.)

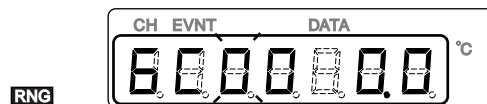

! Handling Precautions

The SRF106 does not have a copy function. Setting values, however, can be copied if you use the Smart Handy Loader SHL100.

[3] Set the recording scale.

1. Press the **SET** key until the SCL LED lights. At first, channel No.1 blinks.

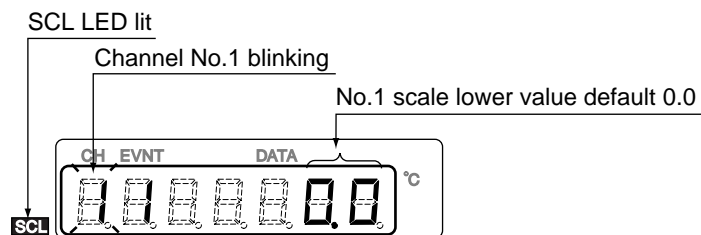

◆◆ To set the No.1 scale “0.0 to 800.0” of channel No.1 ◆◆

2. Press the **ENT** key to advance to display No.2.

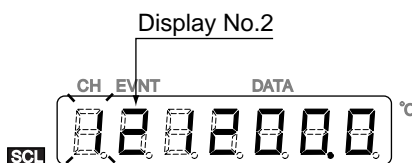

3. Press the **▶** key to shift to the topmost digit of the No.1 scale upper limit setting value. (As the range code has been changed, the value has been automatically changed to the upper limit value (1200°C) of range code 23 that has been set. For this reason, the topmost digit becomes the 1,000's digit.)

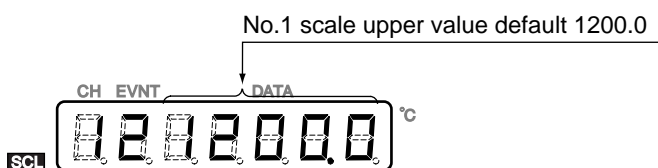

4. Press the ▲ key several times to set the value to “0”.
1000's digit “ 1 ” changes to “ 0 ”



5. Press the ► key to shift to the next digit.



6. Press the ▲ key several times to set the value to “8”.
100's digit “ 2 ” changes to “ 8 ”

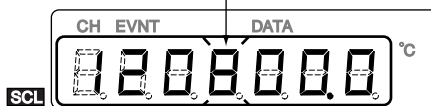

◆◆ To set the No.1 scale “0.0 to 800.0” of channel No.2 ◆◆

7. Press the ENT key several times to set the channel No. to “2”.

No.1 scale lower limit default

Channel No.2 The reason for the indication differing from than in step 3-1 is that the unit is in the direct setting value change mode.

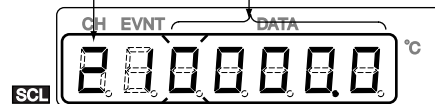

8. Press the ENT key again to advance to display No.2. The display moves to the topmost digit of the No.1 scale upper limit setting.

Display No.2 1000's digit blinks.



9. Press the ▲ key several times to set the value to “0”.
1000's digit “ 1 ” changes to “ 0 ”



10. Press the ► key to shift to the following digit:



11. Press the ▲ key several times to set the value to “8”.

100's digit “ 2 ” changes to “ 8 ”

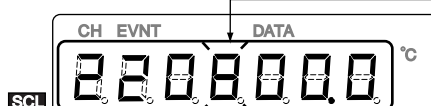

◆◆ To set the No.1 scale “0.0 to 800.0” to channel Nos.3 to 6 ◆◆

Set steps 7. to 11. in the previous example while changing the channel No.

- When you have finished making the No.1 scale upper limit setting for the last channel No.6, be sure to press the **ENT** key. (If you press the **SET** key or **DISP** key without pressing the **ENT** key, and shift to another setup item or display another item, the last setup will not be stored to memory.)

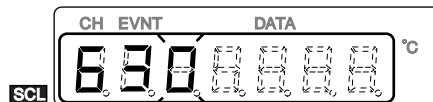

[4] Set the extended menu to OFF.

- Press the **SET** key several times until the SYS LED lights.

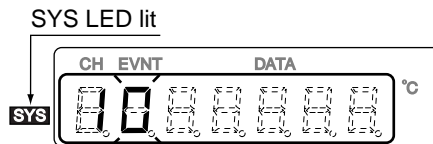

- Press the **ENT** key twice to advance to display No.3.

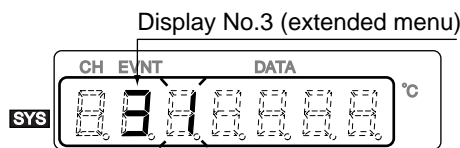

- Press the **▲** key to change the extended menu setting from “1” (ON) to “0” (OFF).

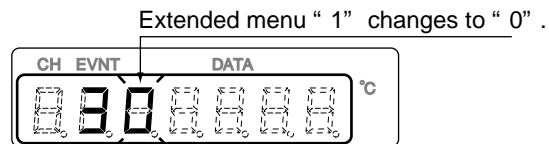

- Press the **ENT** key.

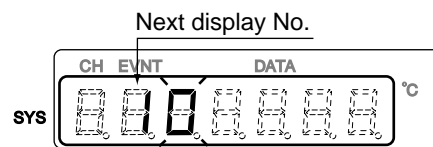

[5] Return to the basic display mode.

- Press the **DISP** key to return to the basic display mode.

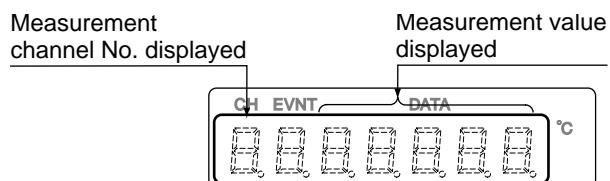

7 - 2 Setup Examples 2

Set the following setting values to your SRF106:

Applicable models: All SRF106 models

Setup conditions: Change the 6th channel in the previous example as follows:

- Input type and recording scale
Set 1 to 5V (equivalent to 0.0 to 2500.0kPa) as the input type to channel 6, and the recording scale to 0.0 to 2000.0kPa.

■ Setup Items

See the table below.

(In this example, let's assume that this setting is to be made after setup example 1 is completed.)

- Columns containing numbers or letters are items that need to be set.
- Blank columns are items that need not be set. (The setup item itself is sometimes not displayed.)
- Some setups may be left at their defaults.

Range Setup

Display No.	Setup Item	Channel					
		1	2	3	4	5	6
1	Recording mode selection						
2	Range code						06
3	Input calculation type						
4	Reference channel						
5	Burnout selection						
6	Measurement range lower limit						1.000
7	Measurement range upper limit						5.000
8	Engineering range decimal point						1
9	Engineering range lower limit						0.0
A	Engineering range upper limit						2500.0
B	Fixed value for deviation						
C	PV bias						
D	Engineering unit setting (UNIT)						20 (blank)
							20 (blank)
							20 (blank)
							6B (k)
							50 (P)
							61 (a)
E	Input tag name setting (TAG)						

Scale Setup

Display No.	Setup Item	Channel					
		1	2	3	4	5	6
1	No.1 scale lower limit						0.0
2	No.1 scale upper limit						2000.0
3	Scale switching method selection						
4	No.2 scale lower limit						
5	No.2 scale upper limit						
6	Auto-switching point						
7	Auto-switching differential						

■ Procedure

- [1] Set the extended menu to ON so that you can configure your SRF106 in more detail (e.g. input type).
- [2] Set the input type.
- [3] Set the recording scale.
- [4] Set the extended menu to OFF.
- [5] Return to the basic display mode.

■ Actual Setup

- [1] Set the extended menu to ON so that you can configure your SRF106 in more detail (e.g. input type).

1. Press the **SET** key several times until the SYS LED lights.

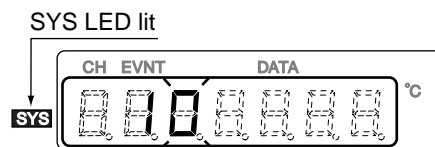

2. Press the **ENT** key twice to advance to display No.3 (extended memory entry).

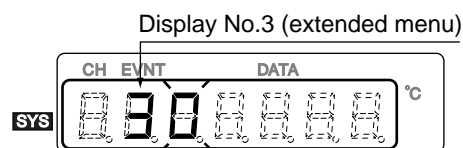

3. Press the **▲** key to change the extended menu setting from "0" (OFF) to "1" (ON).

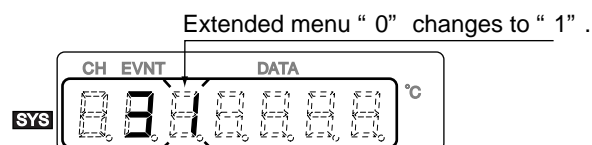

4. Press the **ENT** key.

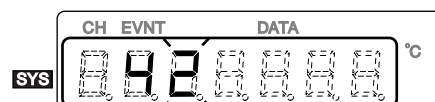

[2] Set the input type.

1. Press the **SET** key until the RNG LED lights. At first, channel No.1 blinks.

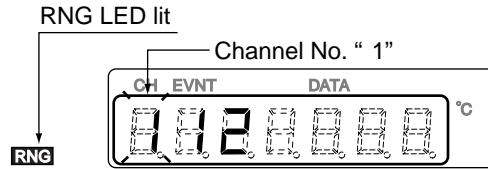

◆◆ To set range code "06" ◆◆

2. Press the **▲** key to change the channel No. from "1" to "6".



3. Press the **ENT** key to advance to display No.2 (range code).

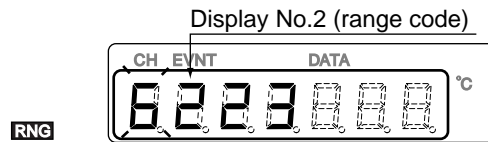

4. Press the **▶** key to shift to the 10's digit of the range code.

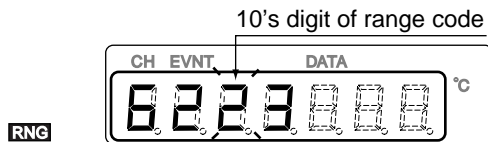

5. Press the **▲** key to change the 10's digit of the range code to "0".

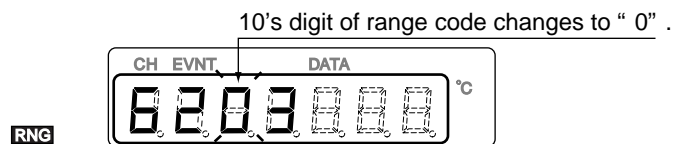

6. Press the **▶** key to shift to the 1's digit of the range code.

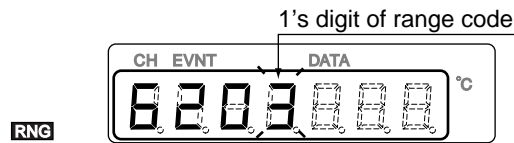

7. Press the **▲** key to change the 1's digit of the range code to "6".

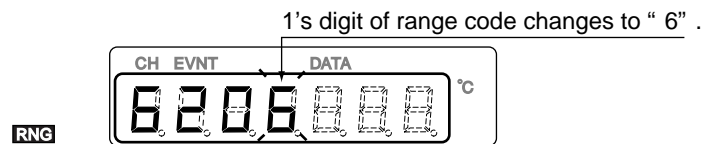

◆◆ To set the measurement range “1.000 to 5.000” ◆◆

8. Press the **ENT** key several times to advance to display No.6 (measurement range lower limit).

Display No.6 (measurement range lower limit)



9. Press the **▶** key to shift to the 1's digit of the measurement range lower limit.

1's digit of measurement range lower limit

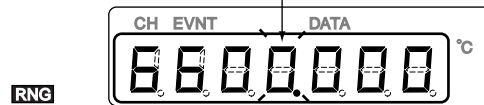

10. Press the **▲** key to change the 1's digit of the measurement range lower limit to “1”.

1's digit of measurement range lower limit changes to “1” .

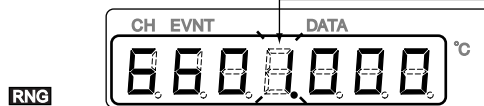

11. Press the **ENT** key to advance to display No.7 (measurement range upper limit).

Display No.7 (measurement range upper limit)



12. Press the **▲** key to change the 10's digit of the measurement range upper limit to “0”.

1's digit of measurement range lower limit changes to “0” .

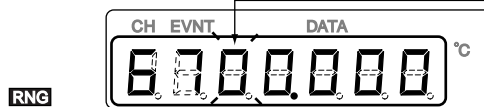

13. Press the **▶** key to shift to the 1's digit of the measurement range upper limit.

1's digit of measurement range lower limit

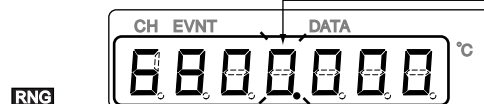

14. Press the **▲** key to change the 1's digit of the measurement range upper limit to “5”.

1's digit of measurement range lower limit changes to “5” .

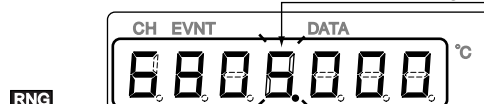

◆◆ To set the engineering range “0.0 to 2500.0” ◆◆

15. Press the **ENT** key to advance to display No.8 (engineering unit range decimal point).

Display No.8 (engineering range decimal point)



16. Press the **▲** key to change the engineering unit decimal point to “1”.

Engineering unit decimal point changes to “1”.



17. Press the **ENT** key to advance to display No.9 (engineering range lower limit).

Display No.9 (engineering range lower limit)

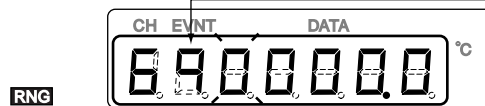

18. When the value is the same as the setup conditions press the **ENT** key and advance to the next display No.A (engineering range upper limit).
If the value is different, press the **▶** and **▲** keys to set the numerical value and press the **ENT** key.

Display No.A (engineering range upper limit)

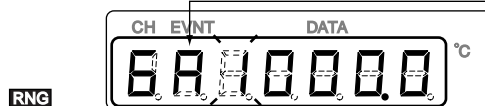

19. Press the **▲** key to change the 1000's digit of the engineering range upper limit to “2”.

1000's digit of engineering range upper limit changes to “2”.

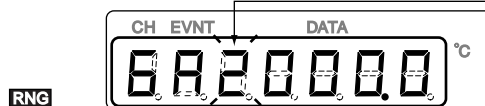

20. Press the **▶** key to shift to the 100's digit of the engineering range upper limit.

100's digit of engineering range upper limit

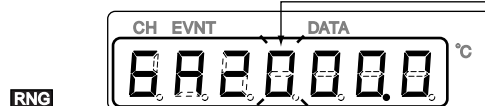

21. Press the **▲** key to change the 100's digit of the engineering range upper limit to “5”.

100's digit of engineering range upper limit changes to “5”.

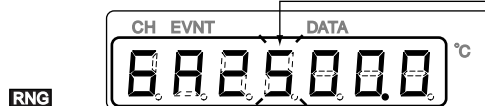

◆◆ To set the engineering unit (kPa) ◆◆

22. Press the  key to advance to display No.D (engineering unit setting).

Display No.D (engineering unit setting)

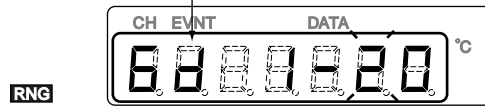

23. Press the  key again to advance to the 4th character of the engineering unit setting.

4th character

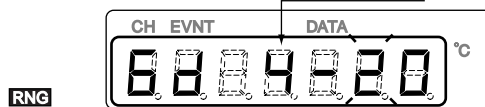

24. Press the  key to change the upper code of the 4th character to "4".

Upper code "4" of 4th character

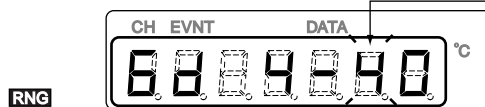

25. Press the  key shift to the lower code of the 4th character.

Lower code "4" of 4th character

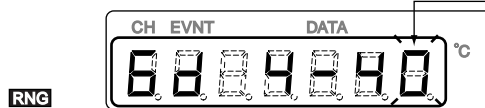

26. Press the  key to change the lower code of the 4th character to "B".

Lower code "B" of 4th character

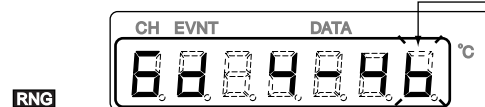

27. Press the  key to advance to the 5th character.

5th character

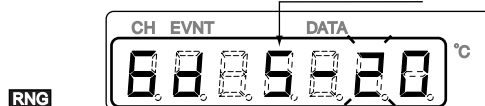

28. Press the  key change the upper code of the 5th character to "7".

Upper code "7" of 5th character



29. Press the  key shift to the lower code of the 5th character.

Lower code of 5th character

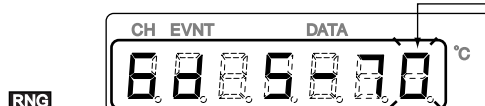

(If the lower code is already “0”, press the **ENT** key to advance to 32.)

30. Press the **▲** key to change the lower code of the 5th character to “0”.

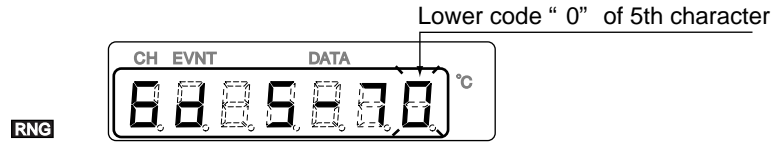

31. Press the **ENT** key to advance to the 6th character.

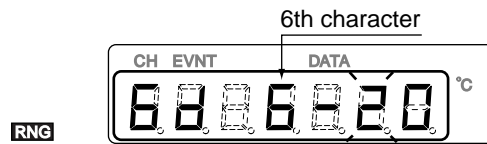

32. Press the **▲** key to change the upper code of the 6th character to “6”.

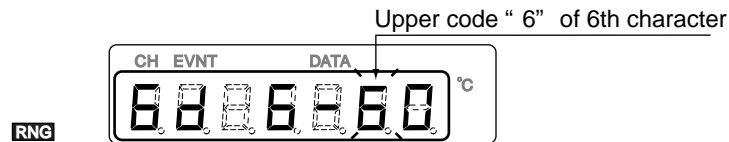

33. Press the **▶** key to the lower code of the 6th character.

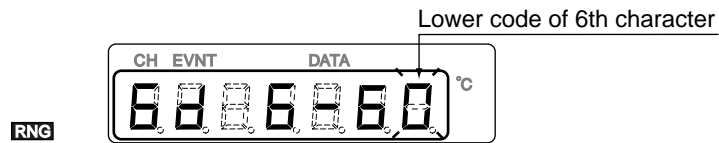

34. Press the **▲** key to change the lower code of the 6th character to “1”.

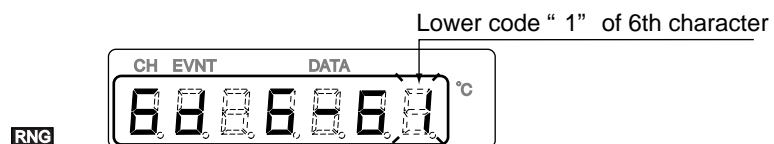

35. Press the **ENT** key to store the setting values to memory.



[3] Set the recording scale.

1. Press the **SET** key until the SCL LED lights. At first, channel No.1 blinks.

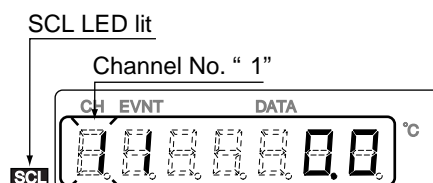

◆◆ To set the No.1 scale (0.0 to 2000.0) ◆◆

2. Press the ▲ key to change the channel No. setting from “1” to “6”.

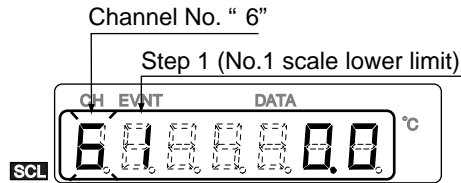

3. If the No.1 scale lower limit is already “0.0”, press the **ENT** key to advance to display No.2. If the setting values are different, use the ► and ▲ keys to set the desired numerical values, and press the **ENT** key.

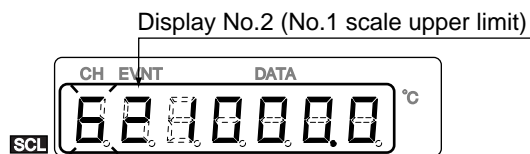

4. Press the ► key to shift to the 1,000’s digit of the No.1 scale upper limit. (If the No.1 scale lower limit numerical value has been changed and display No.2 has been advanced to, operation will start from changing the numerical value of the 1,000’s digit. So this operation is not necessary.)

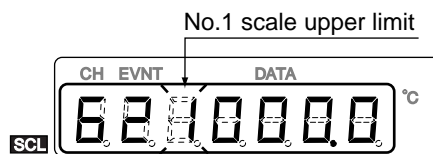

5. Press the ▲ key to change the 1,000’s digit of the No.1 scale upper limit to “2”. Likewise, if the 100’s digit, 10’s digit and 1’s digit are different, use the ► and ▲ keys to set the desired numerical values..

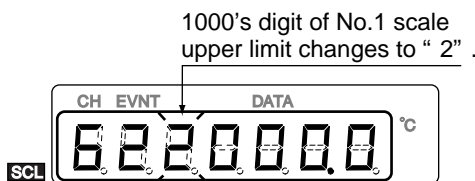

6. Press the **ENT** key to store the setting values to memory.

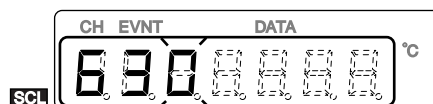

[4] Set the extended menu to OFF.

1. Press the **SET** key several times until the SYS LED lights.

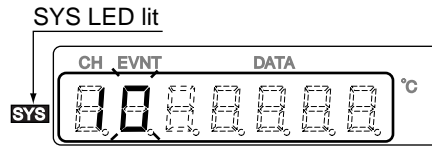

2. Press the **ENT** key twice to advance to display No.3.

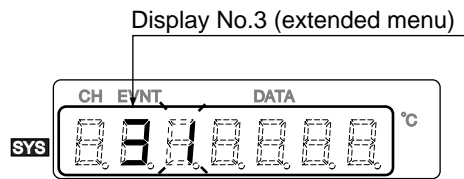

3. Press the **▲** key to change the extended menu settings from "1" (ON) to "0" (OFF).

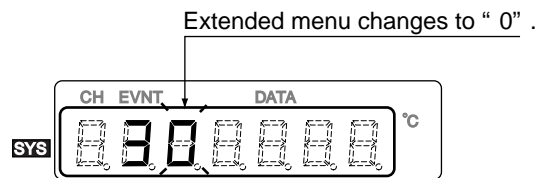

4. Press the **ENT** key.

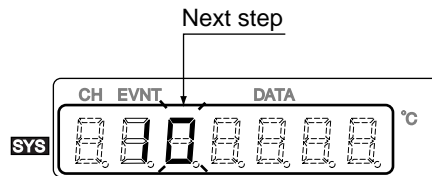

[5] Return to the basic display mode.

1. Press the **DISP** key to return to the basic display mode.

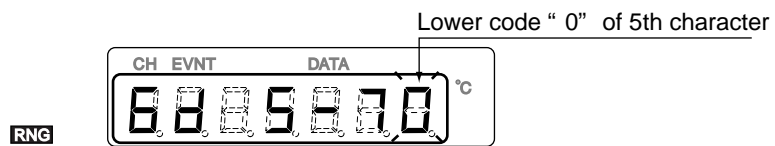

7 - 3 Setup Example 3

Set the following setting values to your SRF106:

Applicable models: SRF106AS[]XXXX (Number in brackets for additional function 1 is 1 or 2.)

(By optional function 1, event relays are supported. Other settings on a standard model are possible, the only difference being that event relays are not supported.)

Setup conditions: The following conditions are added to the details set in the 7-1 Setup Example 1 (page 7-1).

- Set the HIGH (650°C) and LOW (450°C) events to channel No.1, and output each to relay Nos.1 and 2.
- Set HIGH (715°C) to channel No.2 and HIGH (730°C) to channel No.3, and output these in common to relay No.3.
- Set the event differential to 10°C.

■ Setup Items

See the table below.

- Columns containing numbers or letters are items that need to be set.
- Blank columns are items that need not be set. (The setup item itself is sometimes not displayed.)
- Some setups may be left at their defaults.

Event Setup

Display No.	Setup Item	Channel					
		1	2	3	4	5	6
1	No.1 event setting value	650	715	730			
2	No.2 event setting value	450					
3	No.3 event setting value						
4	No.4 event setting value						
5	No.1 event type selection	2 (HIGH)	2 (HIGH)	2 (HIGH)			
6	No.2 event type selection	1 (LOW)					
7	No.3 event type selection						
8	No.4 event type selection						
5	No.1 event output relay No.	1	3	3			
6	No.2 event output relay No.	2					
7	No.3 event output relay No.						
8	No.4 event output relay No.						
5	No.1 event recording ON/OFF	1 (ON)	1 (ON)	1 (ON)			
6	No.2 event recording ON/OFF	1 (ON)					
7	No.3 event recording ON/OFF						
8	No.4 event recording ON/OFF						
9	No.1 event differential	10					
A	No.2 event differential	10					
B	No.3 event differential						
C	No.4 event differential						

■ Procedure

- [1] Set the extended menu to ON so that you can configure your SRF106 in more detail (e.g. input type).
- [2] Select the event type, and set the output relay No. and event differential.
- [3] Set the event setting value.
- [4] Set the extended menu to OFF.
- [5] Return to the basic display mode.

■ Actual Setup

- [1] Set the extended menu to ON so that you can configure your SRF106 in more detail (e.g. input type).

1. Press the **SET** key several times until the SYS LED lights.

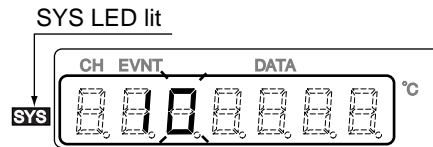

2. Press the **ENT** key twice to advance to display No.3 (extended menu entry).

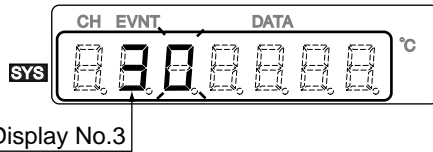

3. Press the **▲** key to change the extended menu setting from "0" (OFF) to "1" (ON).

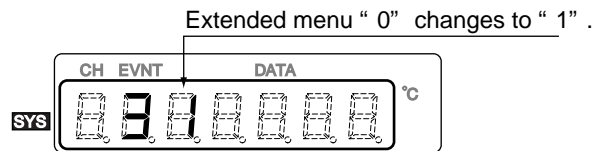

4. Press the **ENT** key.

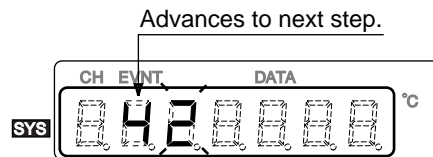

[2] Select the event type for each channel.

1. Press the **SET** key several times until the EVNT LED lights. At first, channel No.1 blinks. When event type is OFF, display No.5 (No.1 event type selection, relay No. selection, recording ON/OFF selection) is displayed.

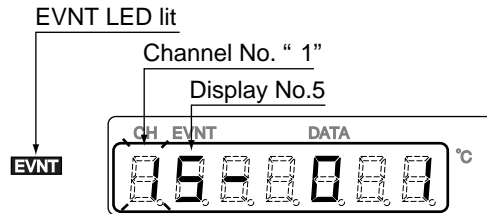

◆◆ To set the event type, relay No. and event differential of channel No.1 ◆◆

2. Press the **▶** key to shift to event type selection.

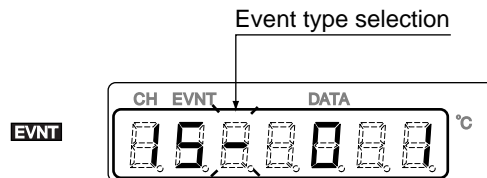

3. Press the **▲** key to change the event type selection to "H (HIGH)".

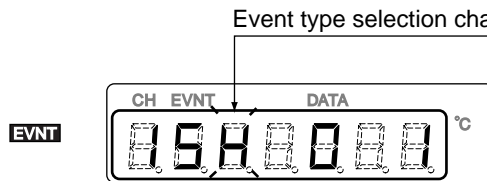

4. Press the **▶** key to shift to the event relay No.

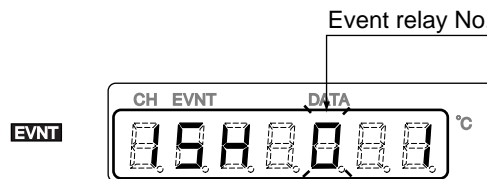

5. Press the **▲** key to change the event relay No. to "1".

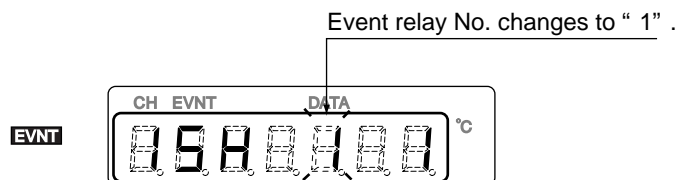

6. Press the **ENT** key to advance to display No.6 (No.2 event type selection, relay No. selection, recording ON/OFF selection).

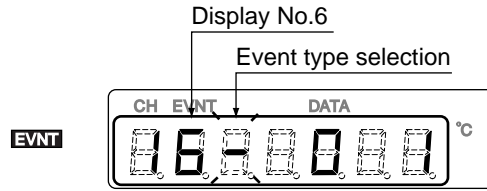

7. Press the **▲** key to change the event type selection to “L (LOW)”.

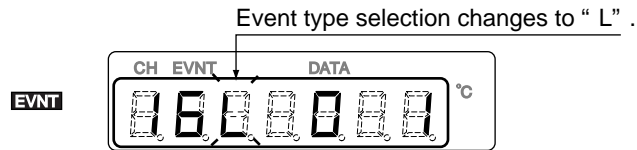

8. Press the **▶** key to shift to the event relay No.



9. Press the **▲** key to change the event relay No. to “2”.

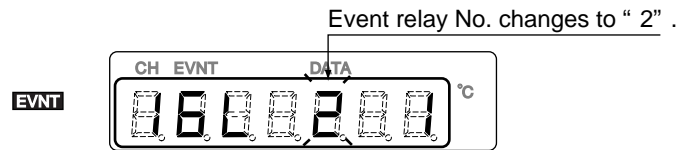

10. Press the **ENT** key to advance to display No.9 (No.1 event differential).

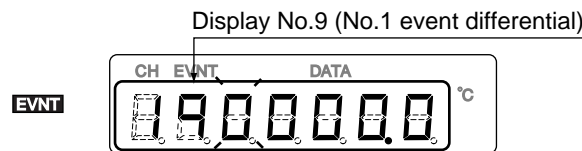

11. Press the **▶** key to shift to the 10’s digit of the event differential.

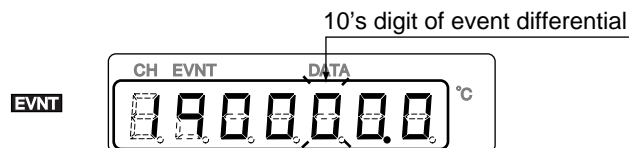

12. Press the **▲** key to change the 10’s digit of the event differential to “1”.

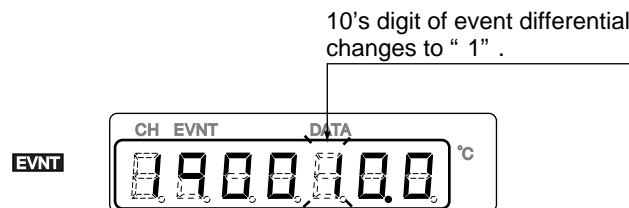

13. Press the **ENT** key to advance to display No.A (No.2 event differential).

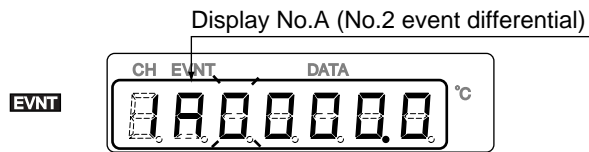

14. Press the **▶** key to shift to the 10's digit of the event differential.

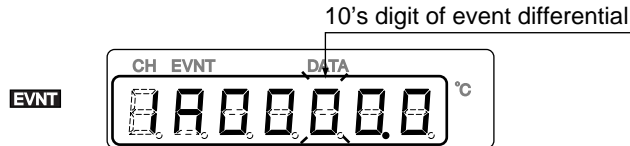

15. Press the **▲** key to change the 10's digit of the event differential to "1".

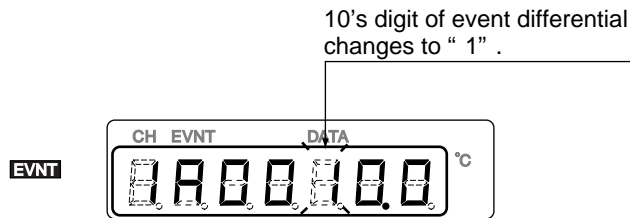

◆◆ To set the event type, relay No. and event differential of channel No.2 ◆◆◆

16. Press the **ENT** key to advance to channel No.2. When event type is OFF, display No.5 (No.1 event type selection, relay No. selection, recording ON/OFF selection) is displayed.

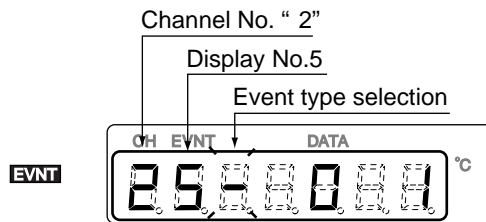

17. Press the **▲** key to change event type selection to "H (HIGH)".

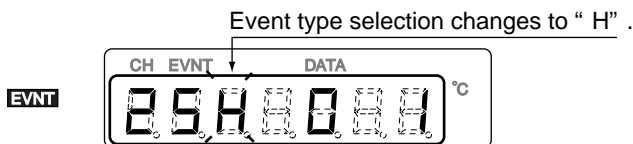

18. Press the **▶** key to shift to the event relay No.



19. Press the ▲ key to change the event relay No. to “3”.

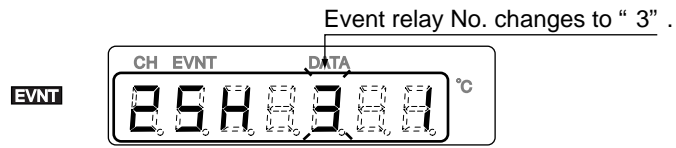

20. Press the ENT key to advance to display No.9 (No.1 event differential).

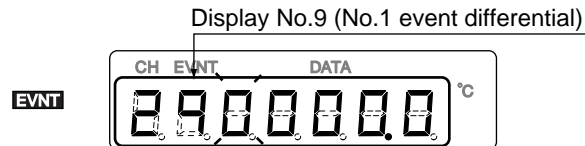

21. Press the ► key to shift to the 10’s digit of the event differential.

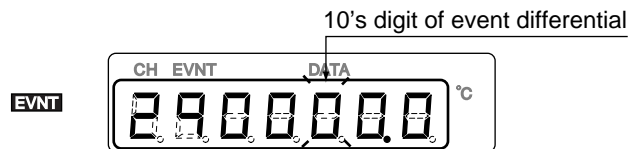

22. Press the ▲ key to change the 10’s digit of the event differential to “1”.

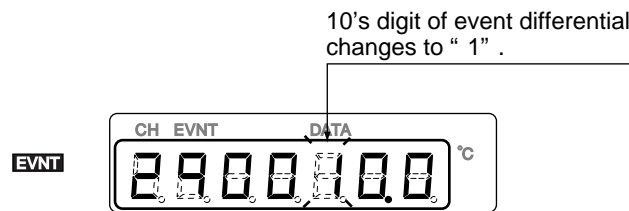

◆◆ To set the event type, relay No. and event differential of channel No.3 ◆◆

23. Press the ENT key to advance to channel No.3. When event type is OFF, display No.5 (No.1 event type selection, relay No. selection, recording ON/OFF selection) is displayed.

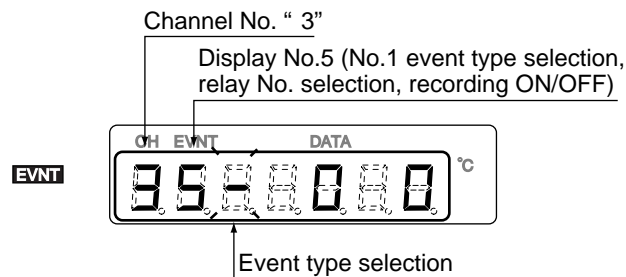

24. ▲ key to change event type selection to “H (HIGH)”.

Event type selection changes to “H” .

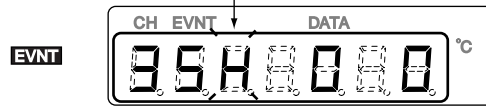

25. Press the ► key to shift to the event relay No.

Event relay No.

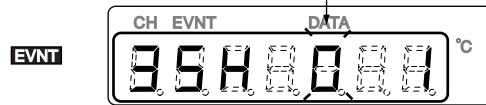

26. Press the ▲ key to change the event relay No. to “3”.

Event relay No. changes to “3” .

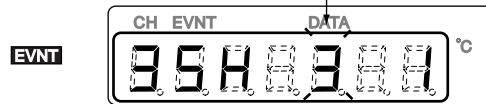

27. Press the ENT key to advance to display No.9 (No.1 event differential).

Display No.9 (No.1 event differential)

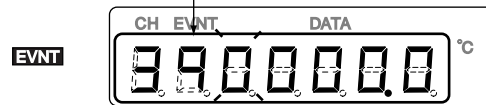

28. Press the ► key to shift to the 10’s digit of the event differential.

10’s digit of event differential

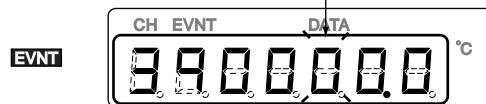

29. Press the ▲ key to change the 10’s digit of the event differential to “1”.

10’s digit of event differential changes to “1” .



30. Press the ENT key.

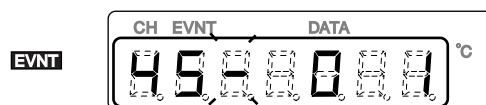

[3] Set the event setting value.

1. Press the **▶** key to shift to the channel No.

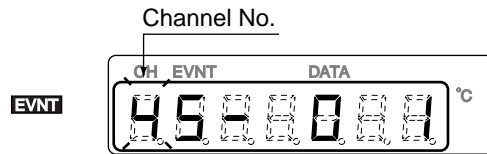

◆◆ To set the event setting value of channel No.1 ◆◆

2. Press the **▲** key to change the channel No. to “1”.

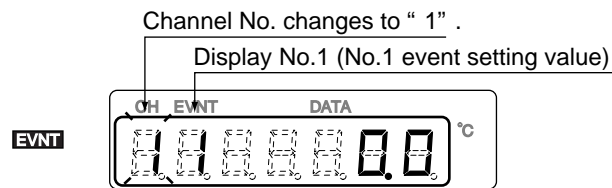

3. Press the **▶** key to shift to the 100's digit of the No.1 event setting value.

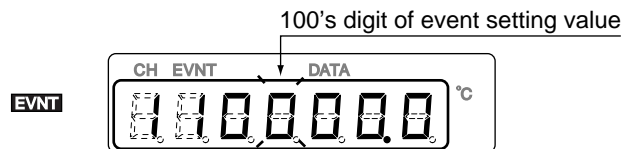

4. Press the **▲** key to change the 100's digit of the No.1 event setting value to “6”.

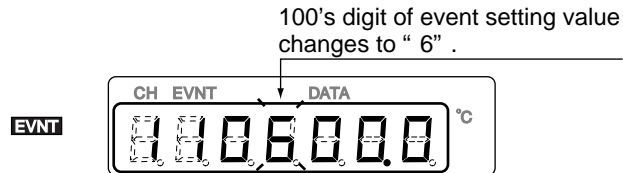

5. Press the **▶** key to shift to the 10's digit of the No.1 event setting value.

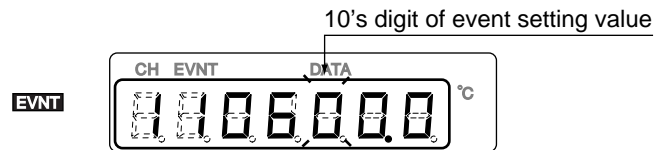

6. Press the **▲** key to change the 10's digit of the No.1 event setting value to “5”.

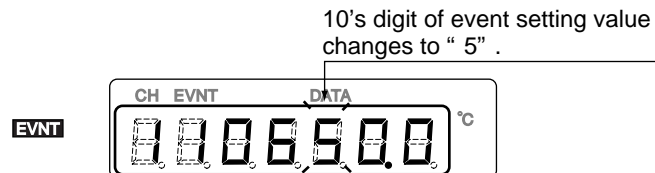

7. Press the **ENT** key to advance to display No.2 (No.2 event setting value).

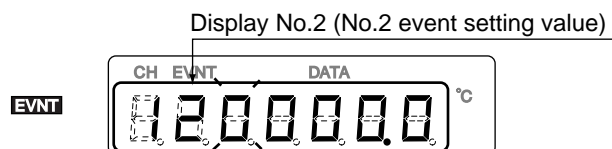

8. Press the **▶** key to shift to the 100's digit of the No.2 event setting value.

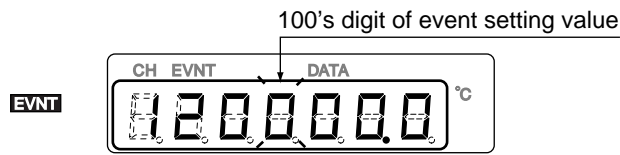

9. Press the **▲** key to change the 100's digit of the No.2 event setting value to "4".

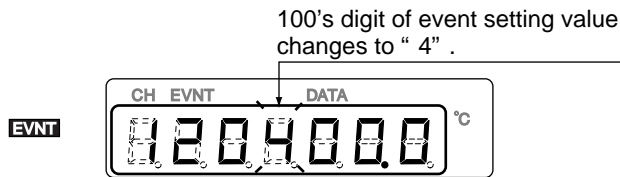

10. Press the **▶** key to shift to the 10's digit of the No.2 event setting value.

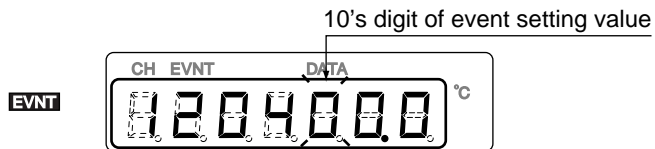

11. Press the **▲** key to change the 10's digit of the No.2 event setting value to "5".

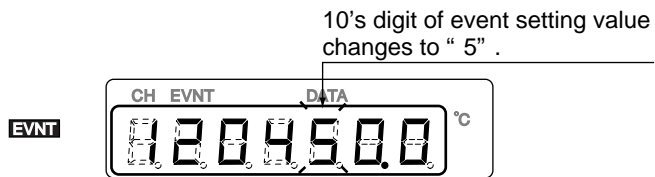

12. Press the **ENT** key.



13. Press the **▶** key to shift to the channel No.



◆◆ To set the event setting value of channel No.1 ◆◆

14. Press the **▲** key to change the channel No. to "2".

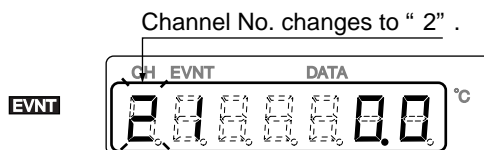

15. Press the **▶** key to shift to the 100's digit of the No.1 event setting value.

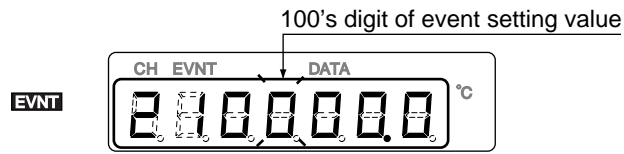

16. Press the **▲** key to change the 100's digit of the No.1 event setting value to "7".

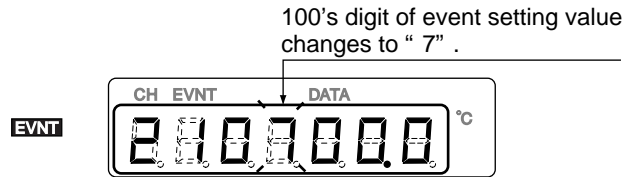

17. Press the **▶** key to shift to the 10's digit of the No.1 event setting value.

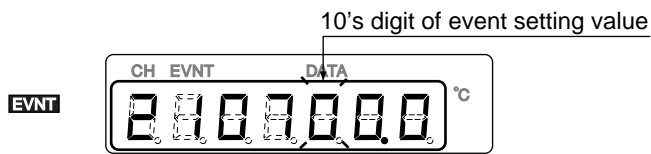

18. Press the **▲** key to change the 10's digit of the No.1 event setting value to "1".

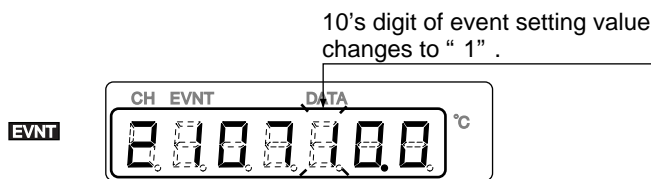

19. Press the **▶** key to shift to the 1's digit of the No.1 event setting value.

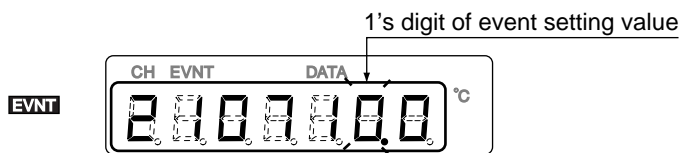

20. Press the **▲** key to change the 1's digit of the No.1 event setting value to "5".

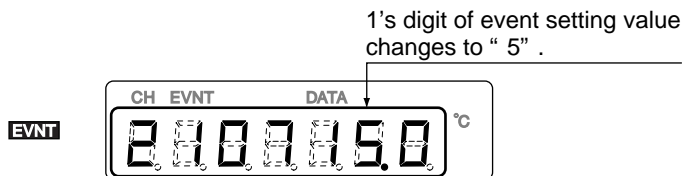

21. Press the **ENT** key.



22. Press the **▶** key to shift to the channel No.
Channel No.

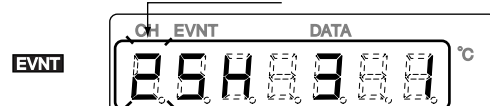

◆◆ To set the event setting value of channel No.1 ◆◆

23. Press the ▲ key to change the channel No. to “3”.

Channel No. changes to “3” .

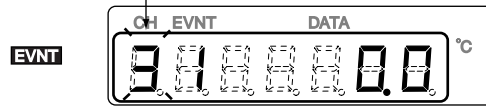

24. Press the ► key to shift to the 100's digit of the No.1 event setting value.

100's digit of event setting value

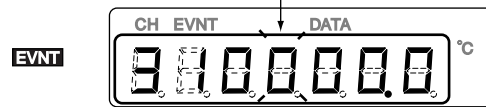

25. Press the ▲ key to change the 100's digit of the No.1 event setting value to “7”.

100's digit of event setting value changes to “7” .

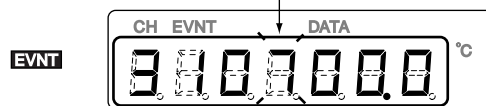

26. Press the ► key to shift to the 10's digit of the No.1 event setting value.

10's digit of event setting value



27. Press the ▲ key to change the 10's digit of the No.1 event setting value to “3”.

10's digit of event setting value changes to “3” .

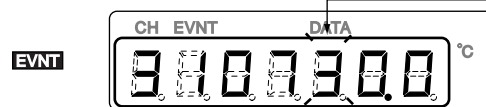

28. Press the ENT key.

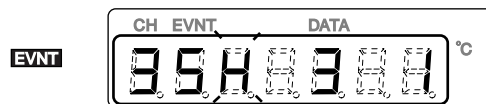

[4] Set the extended menu to OFF.

1. Press the **SET** key several times until the SYS LED lights.

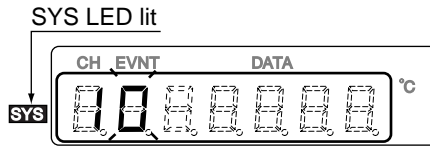

2. Press the **ENT** key twice to advance to display No.3.

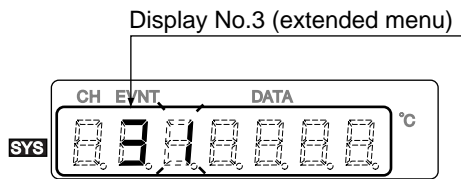

3. Press the **▲** key to change the extended menu setting from "1" (ON) to "0" (OFF).

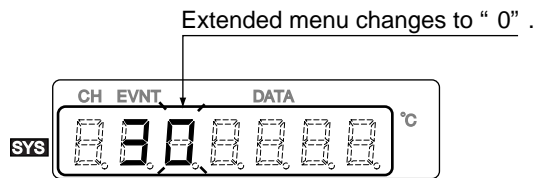

4. Press the **ENT** key.

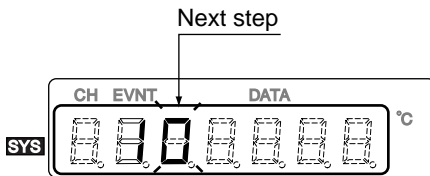

[5] Return to the basic display mode.

1. Press the **DISP** key to return to the basic display mode.

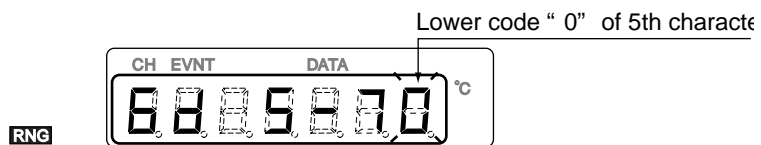

Chapter 8. MAINTENANCE

8 - 1 Periodic Inspection

To ensure prolonged use of the SRF106, periodically inspect the operating status of the SRF106 and maintain it in a proper working condition. Perform the following inspections, and replace consumables and maintenance parts as required:

■ Faint Recording or Printing

- ⇒ For details on how to replace the ink ribbon cassette, see 4-1 Preparation (loading the chart and ink ribbon cassette) (page 4-1).
(The life of the ink ribbon is about three months at a chart feed speed of 20mm/h.)

■ Incorrect Feeding of Chart, Paper Jam

- ⇒ Re-load the chart referring to 4-1 Preparation (loading the chart and ink ribbon cassette) (page 4-1).

■ Insufficient Remaining Chart

- ⇒ The remaining amount of chart is printed at 10cm intervals on the right side of the chart. When only 60cm of chart remains, the remaining chart warning is printed on the chart.
Replace with new chart referring to 4-1 Preparation (loading the chart and ink ribbon cassette) (page 4-1).

■ Alarm Code “A L O 3” Displayed

- ⇒ Replace with a new battery referring to 8-2 Replacing the Clock Backup Battery (page 8-3).

■ Alarm Code Other Than “A L O 3” Displayed

- ⇒ Refer to Chapter 9 TROUBLESHOOTING. We also recommend periodically cleaning the SRF106.

● When dust is collecting inside the SRF106:

Wipe off any dust inside the SRF106 with a soft brush, and suck up the dust with a vacuum cleaner. Also, use soft cloth or paper that does not produce any fluff to prevent the shaft from becoming scratched. Wipe the shaft with soft cloth or paper moistened with ethyl alcohol only when it is difficult to remove dirt or stains from the shaft.

❗ Handling Precautions

- When cleaning the SRF106, take care not to damage the flexible board on the printer section.
- The SRF106 does not need to be lubricated with lubricating oil. Do not apply lubrication oil to any parts or components on the SRF106. Doing so might attract dust or increase wear.
- When cleaning the shaft, be sure to use cloth or paper that does not produce any fluff. Fluff adversely affects operation of the printer.
Recommended cleaning cloth: Kim Wipe® made by Crecia Co., Ltd.

● When dust is collecting on the door window:

Wipe dust from the door window using soft dry cloth or paper.

❗ Handling Precautions

Never wipe the door window with paint thinner or other organic solvents. Doing so might cause the window to crack or cloud.

We recommend carrying out the following when you are not using the SRF106 for a long time:







1. Remove the ink ribbon cassette, insert the cassette into a vinyl bag and seal the bag.
2. Remove the chart from the chart cassette, and return the chart to the chart box.

! **Handling Precautions**

- If you leave the SRF106 for a long time with the ink ribbon cassette loaded in the SRF106, ink will become faint on only the parts that contact the air. For this reason, part of the recording may become faint at periodic intervals when the SRF106 is next used.
- If you leave the SRF106 for a long time with the chart loaded in the chart cassette, the chart may become discolored due to sunlight or it may become wrinkled. For this reason, the chart may not fold properly when the SRF106 is next used.

8 - 2 Replacing the Clock Backup Battery

WARNING

-  To prevent danger before you replace the clock backup battery, turn the power OFF, and disconnect the SRF106 from its power supply.
-  Do not insert the battery with the polarities (+ , -) reversed.
-  Do not use damaged (broken battery skin, leaking battery fluid) batteries.
-  Do not throw batteries into fires, or charge, short-circuit, disassemble or heat batteries.
-  Store batteries out of the reach of small children. Batteries are small and are easy to swallow. If a child swallows a battery, consult a physician immediately.
-  When disposing of used batteries at the user site, observe local bylaws.

The clock backup battery is for backing up the clock data in the event of a power interruption and memorizing the recording start/stop state.

The life of the clock backup battery is about five years. If you forget to replace the battery, or the battery is out of power, alarm code “A L O 3” is displayed on the display when the power is turned ON, clock data is initialized to “00/01/01 00: 00”, and the recording mode is set forcibly to the recording start mode.

Though the SRF106 can be operated in this state, we recommend replacing the clock backup battery as soon as possible.

Various setup data are stored to nonvolatile memory. So, these data need not be reset when the clock backup battery is replaced.

Lithium battery (CR2430)

(Buy at an electrical appliance or camera store.)

- **Draw out the chart cassette.**

For details on how to draw out the chart cassette, see 4-1 Preparation (loading the chart and ink ribbon cassette) (page 4-1).

- **Remove the two screws fastening the chassis.**

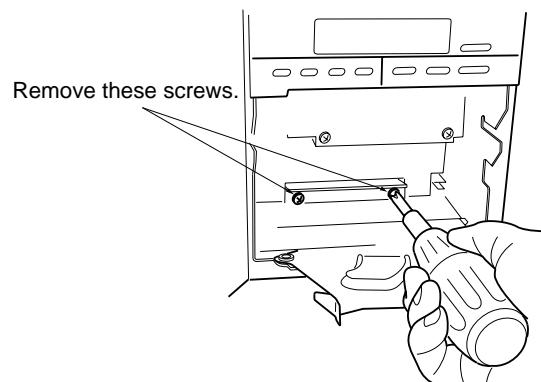

- Pull out the chassis to draw out.

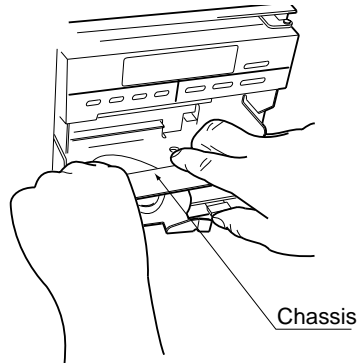

- Draw out the chassis.

! Handling Precautions

Attach the springs attached to the left side of the chassis to their original positions if they come loose.

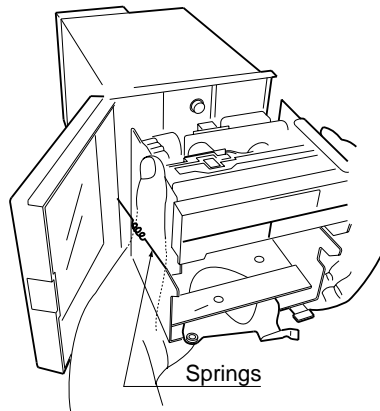

- Place the chassis on the flat, stable location.

! Handling Precautions

Place the chassis at a location where static electricity is not produced.

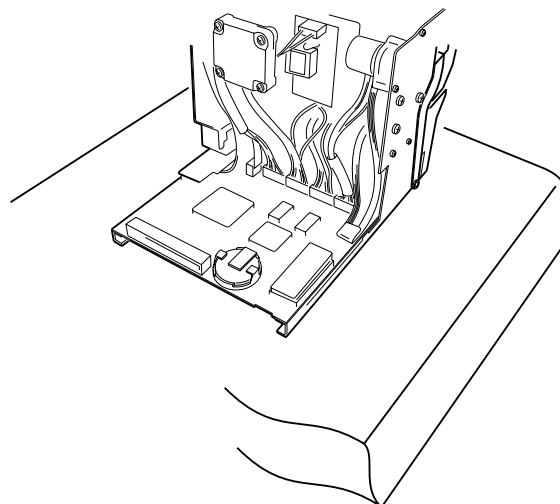

- Remove the battery from its holder.

- ❗ **Handling Precautions**

- Touch only the battery holder. Do not touch other parts with your hands.
 - Take care to prevent surrounding parts or the PCB pattern from becoming scratched.

1. Lift up the battery from the battery holder on the board inside.

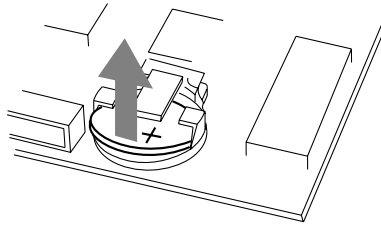

2. Remove the battery from its holder.

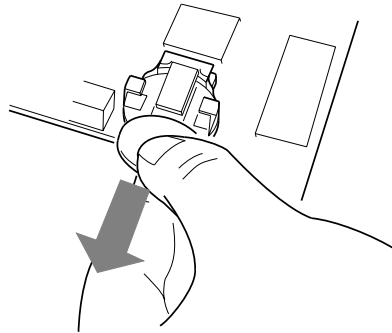

3. Insert a new battery into the battery holder with the plus (+) side facing up.

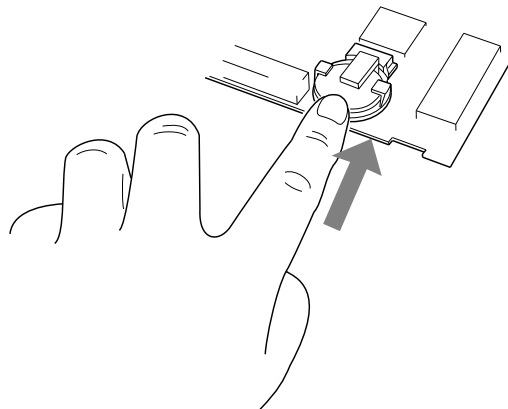

4. Return the chassis to its original position, and turn the power ON. Reset the date and time.

8 - 3 Replacing the Fuse

WARNING



To prevent danger before you replace the fuse, turn the power OFF, and disconnect the SRF106 from its power supply.



To prevent fire, use only the specified fuse. Do not use other fuses.
Replacement part No.: 81446289-001 (10-fuse pack)
Fuse rating: 2A 250V to time-lag (IEC127)

Handling Precautions

Replace fuses periodically (about every two years) to prevent unexpected blowing.

● **Draw out the chassis.**

For details on how to draw out the chassis, see pages 8-2 and 8-3.

● **The fuse holder is located on the side of the case. Turn the screw counterclockwise to remove the fuse.**

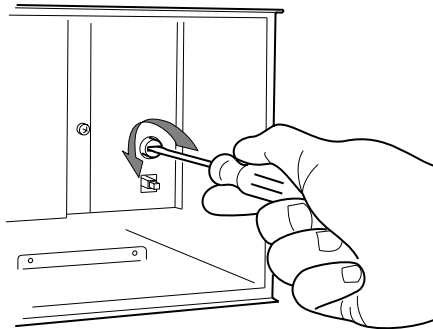

● **Insert the new fuse in the fuse holder, and turn the screw in the clockwise direction to fasten the fuse holder.**

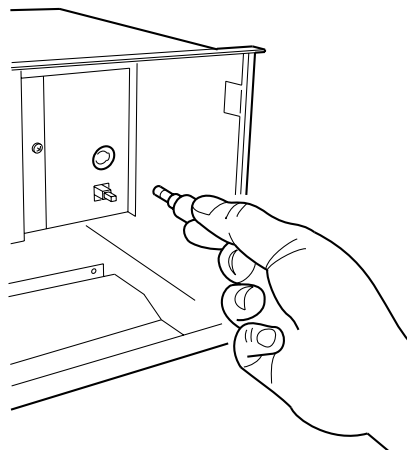

8 - 4 Chart Illumination Lamp

A cold cathode fluorescent light is used as the chart illumination lamp.

If this lamp must be replaced, contact your dealer for a new lamp.



Note

The brightness half-life (time that it takes for the brightness at purchase to reduce by half) of this lamp is about 20,000h under normal-temperature lighting conditions.

8 - 5 Measuring the Display Accuracy of Analog Inputs

This section describes how to measure the display accuracy (including digital printing by tabulation) of analog inputs. We recommend measuring the display accuracy of analog inputs once every year to ensure appropriate use of the SRF106.

If, as a result of measurement, it is found that accuracy deviates from the specified display accuracy of the SRF106 (see 10-2 Input Types, Ranges and Display Accuracy (page 10-6)), perform one-point adjustment using the PV bias (see 6-7 Range Setup (page 6-12)). If the SRF106 needs to be calibrated, contact your dealer.

■ Equipment Required for Measurement

The standard display accuracy of the SRF106 is 0.15%. When measuring the standard display accuracy, use equipment having an accuracy higher than this.

- DC standard voltage generator: When measuring DC voltage and thermocouple inputs
- Cold junction compensator (icebox): When measuring thermocouple inputs
- Dial variable resistor: When measuring resistance temperature detectors (RTD)

■ Measurement Environment

The standard display accuracy of the SRF106 is based upon the standard conditions listed in 10-1 Specifications (page 10-1). These conditions must also be satisfied when measuring the accuracy of analog inputs. If accuracy is measured outside of these conditions, the following additional accuracies must be included the display accuracy measurement:

● Additional accuracies

(ambient temperature characteristics)

- Indication and recording fluctuations in response to temperature changes of $\pm 10^{\circ}\text{C}$:
(excluding standard contact temperature compensation error at thermocouple input)
Indication fluctuation: Within $\pm(0.1\% \text{ F.S.} + \text{resolution} \times 2)$
Recording fluctuation: Within (display fluctuation) + (0.5% F.S.)
(excluding influence of chart expansion/shrinkage)

(ambient humidity characteristics)

- When humidity changes from 60% to 85%RH:
Indication fluctuation: Less than $\pm 0.1\% \text{ F.S.}$
- When humidity changes from 60% to 45%RH:
Indication fluctuation: Less than $\pm 0.1\% \text{ F.S.}$

■ Procedure

- Wire to each of the input types as shown in the figure on the right, and warm up the recorder for at least 60min.
- Make sure that the ambient temperature, humidity and other environmental conditions are within their respective standard conditions.
- Apply inputs equivalent to 0% and 100% of the input range, read the indications at this time, and measure the error from the difference with the input values.

● When measuring DC voltage

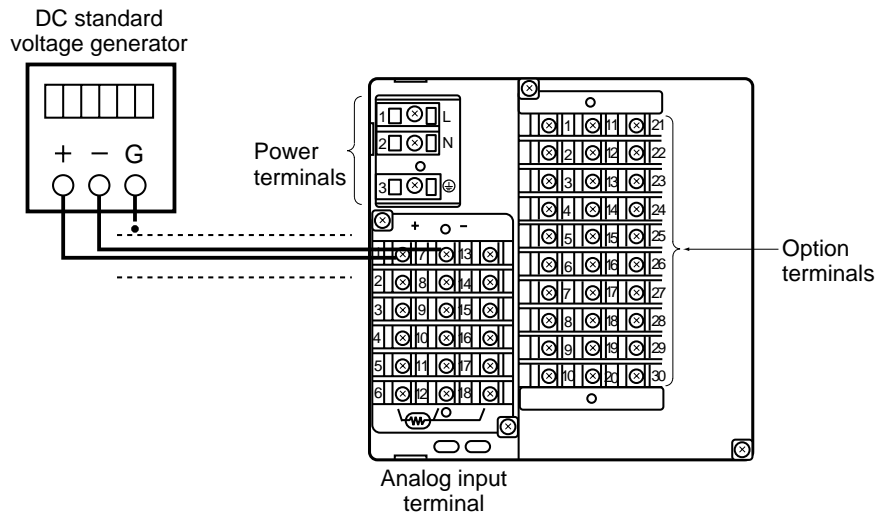

● When measuring a thermocouple

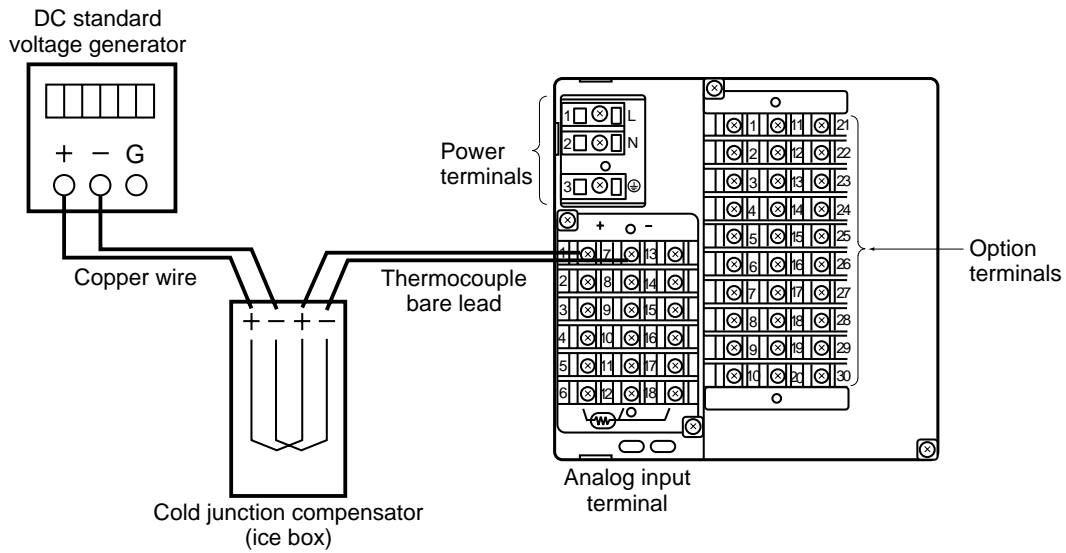

● When measuring a resistance temperature detector

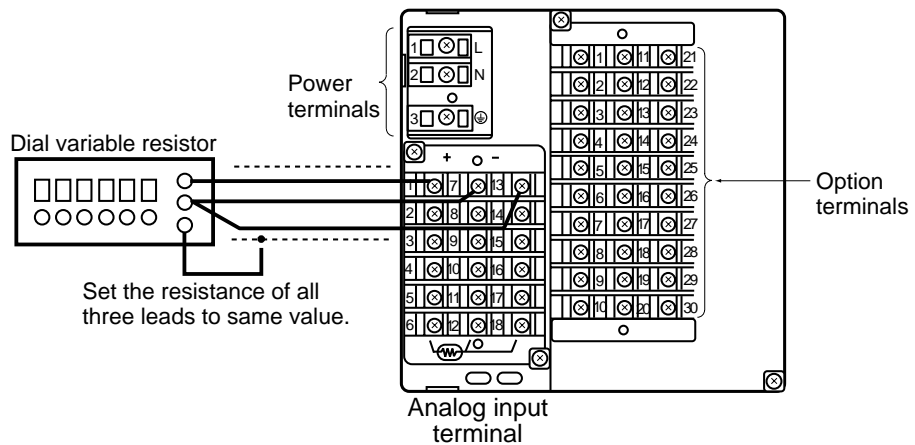

8 - 6 Adjusting the Dot Position

This section describes how to adjust the dot position on the chart.

This adjustment should be performed when the recording accuracy has drifted outside of the permissible accuracy range. The dot position is factory-adjusted, and normally need not be re-adjusted.

To perform this adjustment, the SRF106 must be set to the calibration mode. All adjustment data for the SRF106 is input to this mode by a special device during production. Inadvertently rewriting this data may cause the SRF106 to malfunction and may prevent on-site recovery. Never change any setting other than the required settings.

Also, the chassis must be drawn out to enter the calibration mode. Take care when drawing out the chassis. Take the following points into consideration.

- The recording accuracy indicated in Chapter 10. SPECIFICATIONS assumes that ambient temperature, humidity and other environmental conditions are within their respective standard conditions.
- Otherwise, chart expansion/shrinkage must also be taken into consideration.

■ About Recording Accuracy

● Recording accuracy

In PV axis (horizontal) direction: Display accuracy + ($\pm 0.5\%$ of recording F.S.)

In time axis (vertical) direction: $\pm 0.5\text{mm}$

● Chart expansion/shrinkage (in horizontal direction)

- The chart expands about 0.7% F.S. when the ambient temperature changes from 60% to 85%RH.
- The chart shrinks about 0.2% F.S. when the ambient temperature changes from 60% to 45%RH.

■ About Standard Conditions

- Temperature: $23\pm 2^\circ\text{C}$
- Humidity: $60\pm 5\% \text{RH}$
- Mounting: Horizontal

■ Procedure

1. Make sure that the standard environmental conditions described on the previous page are satisfied, and then turn the power OFF.
2. Draw out the chassis according to the procedure described on pages 8-3 and 8-4.
3. Switch the on-board mode selector pin W1 to “CAL” from “REC”.

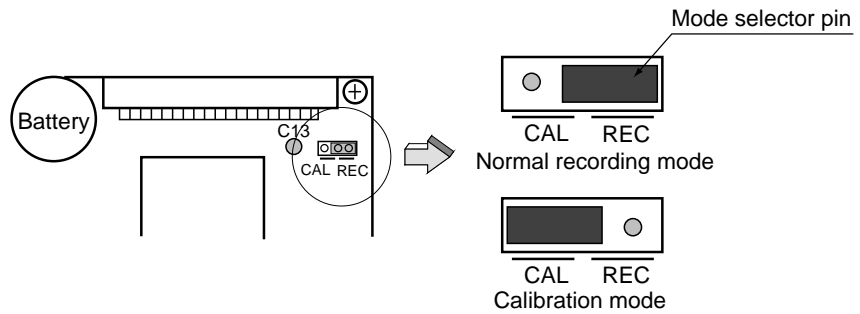

4. Install the chassis.
5. Turn the SRF106 ON with the **SET** and **RCD** keys held down simultaneously.
6. Press the **▲** key to display dot position adjustment item “b”.
7. Press the **▶** key to move the cursor (blinking digit) to the right, and press the **▲** key to set adjustment setup item No. “1”.

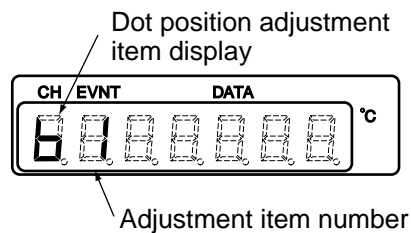

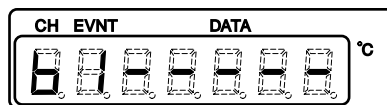

8. Press the **ENT** to start the dot position adjustment. The DATA LEDs blink, and dot printing is started using the current dot position adjustment data.



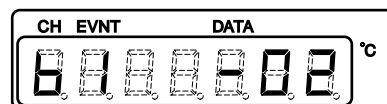

9. Blinking of the DATA LEDs stops, and the current dot position adjustment value data is displayed.



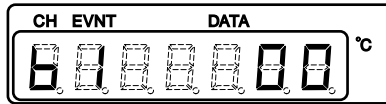

10. Adjust the dot position using the  /  keys.

- ◇ Pressing the  key moves the head position to the right. A value incremented by “1” is displayed as the adjustment data value.
- ◇ Pressing the  key moves the head position to the left. A value decremented by “-1” is displayed as the adjustment data value.



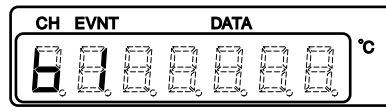

11. After the dot position is aligned to the 0% position on the chart, press the  key to write the adjustment data value. Dot printing stops at this time.

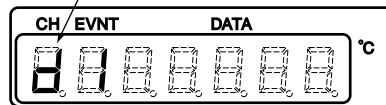

12. To finally store the adjustment data, press the  key to move the cursor, and press the  key to display final adjustment item “d”.

Final stored value for the adjustment data value



13. Press the  key to execute the final writing operation. The DATA LEDs blink during this operation.

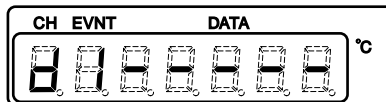

14. Blinking of the DATA LEDs stops, and the adjustment data is written.

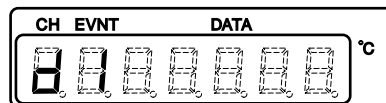

15. Turn the power OFF.

16. Draw out the chassis.

17. Switch the mode selector pin to the “REC” side.

18. Return the chassis to its original position.

Chapter 9. TROUBLESHOOTING

9 - 1 Alarm Display and Descriptions

This recorder is provided with a self diagnostics function that monitors the functions at all times. If an error is detected, an alarm code is displayed on the display, and not in the configuration display.

If a function is judged to be in error, a predetermined operation according to the alarm type is carried out.

If two or more errors are judged to have occurred simultaneously, alarm codes are displayed successively from the lowest number alternating with regular display. To cancel display of an alarm code, turn the power OFF then back ON again unless otherwise mentioned.

If an alarm code stays displayed even though a remedy has been carried out, contact us for repair.



(display example)

◆ Alarm display: diagnostic item

- ◇ Description of alarm
- Recorder operation
- ⇒ Remedy

◆ A L O 1: printer position diagnosis

- ◇ The reset position of the wire dot head is checked to see if it can be detected.
- The alarm code is displayed, and recording stops. Operations except recording are continued.
- ⇒ Check to see if the chart is not touching the printer or the chart holder springs.

◆ A L O 2: ribbon position diagnosis

- ◇ The reset position of the ink ribbon cassette holder is checked to see if it can be detected.
- The alarm code is displayed, and recording stops. Operations except recording are continued.
- ⇒ Check to see if the ink ribbon is entangled with the wire dot head.

◆ A L O 3: clock backup battery diagnosis

- ◇ The clock backup battery is checked when the power is turned ON.
- The alarm code is displayed, and recording continues. At this time, the date and time are initialized to "00/01/01, 00:00". Storage of recording operation (recording ON/OFF) is forcibly set to "recording ON", and recording is started by recording ON even if recording previously ended by recording OFF.
- ⇒ Replace the lithium battery.

◆ A L O 4: reference contact temperature diagnosis

- ◇ The reference contact temperature range (-30°C to +80°C) is checked.
- The alarm code is displayed, and operation continues. At this time, either -30°C or +80°C is used as the reference contact temperature. So, data is not reliable.
- ⇒ Ask for repair.

◆ A L O 5: A/D converter diagnosis

- ◇ A/D converter operation is checked.
- The alarm code is displayed, and operation continues. At this time, an unstable value is indicated as the PV value. So, data is not reliable.
- ⇒ Ask for repair.

◆ **AL06: reference voltage diagnosis**

- ◇ The reference voltage A/D conversion value range is checked.
- The alarm code is displayed, and operation continues. At this time, design values are used for the reference voltage value. So, data is not reliable.
- ⇒ Ask for repair.

◆ **AL07: auto zero entry diagnosis**

- ◇ The auto zero A/D conversion value range is checked.
- The alarm code is displayed, and operation continues. At this time, design values are use for the auto zero value. So, data is not reliable.
- ⇒ Ask for repair.

◆ **AL08: ROM diagnosis**

- ◇ The checksum is verified over all areas when the power is turned ON.
- The alarm code is displayed, and all operations stop.
- ⇒ Ask for repair.

◆ **AL09: RAM diagnosis**

- ◇ The RAM is checked when the power is turned ON.
- The alarm code is displayed, and all operations stop.
- ⇒ Ask for repair.

◆ **AL10: EEPROM diagnosis**

- ◇ The EEPROM is checked when data is written.
- The alarm code is displayed, and operation continues. At this time, data in RAM is used as the data.
- ⇒ Ask for repair.

◆ **AL11: calibration data diagnosis**

- ◇ The checksum of the calibration data in EEPROM is verified when the power is turned ON.
- The alarm code is displayed, and all operations stop.

- ◇ During operation, the checksum is periodically verified. During an alarm, the data in EEPROM is copied to RAM, and is checked again.
- The alarm code is displayed, and operation continues. At this time, design values are used as calibration data. So, data is not reliable.
- ⇒ Ask for repair.

◆ A L 1 2: configuration data diagnosis

- ◇ A verify check is carried out on all range data when range data is written. During an alarm, data in RAM is copied to EEPROM, and the verify check is carried out on this data.
- The alarm code is displayed, and operation continues. At this time, data in RAM is used as range data.
- ⇒ Reset the configuration data. If this error reoccurs after carrying out the remedy, ask for repair.

◆ A L 1 3: mode selector pin diagnosis

- ◇ If the normal mode is entered after the power is turned ON, the mode selector pin is read. If the calibration mode cannot be entered when the power is turned ON with the mode selector pin inserted in the calibration mode position, this is judged to be a diagnostics error.
- The alarm code is displayed, and operation continues.
- ⇒ Return the mode selector pin to the REC mode position.

◆ A L 1 6: Calendar IC diagnosis

- ◇ An error is judged if the internal setting data of the calendar IC is illegal.
- The alarm code is displayed, and operation continues.
- ⇒ Reset the clock. If this error reoccurs after the clock is reset, ask for repair.

◆ No display: watchdog timer diagnosis

- ◇ When a time-out error occurs on the watchdog timer, this is judged to be a diagnostic error.
- The recorder restarts automatically.

9 - 2 Remediating Trouble

Trouble	Probable Cause	Remedy
No operation (e.g. display, recording)	Power is not being supplied to the main unit.	Check the wiring and power voltage, and supply the power correctly.
	The power switch on the main unit is OFF.	Set the power switch at the top right on the main unit to ON.
	The fuse has blown.	Remove the cause of the fuse blowing, and replace the fuse. (See page 8-6.)
	The chassis is not correctly inserted.	Correctly insert the chassis. (Note 1)

Note 1: A probable cause is a damaged connector on the driver board mounted on the chassis. Check this when the chassis is re-attached.

Trouble	Probable Cause	Remedy
Pressing the  key does not advance the display to PV value display.	The recording mode for all channels is set to " display/recording OFF" .	Set the recording mode for the required channels.
" ALXX" is displayed on the display.	An error was found during self diagnostics.	Remedy by referring to pages 9-1 to 9-3.
Recording is not carried out even though PV value display is normal.	The recording mode for all channels is set to " display only" .	Set the recording mode for the required number of channels.
	Recording is not ON.	Press the (RCD) key to start recording.
	The ink ribbon has reached the end of its life.	Replace with a new ink ribbon cassette. (See page 4-4.)
	The ink ribbon is not loaded.	Attach the ink ribbon cassette. (See page 4-1.)
	The ink ribbon is not passing along the correct path.	Pass the ink ribbon between the printer and chart. (See page 4-5.)
	The chart cassette is not loaded correctly.	Push the cassette in as far as possible, and press the load lever. (Note 2)
Incorrect recording color	The ink ribbon is not loaded correctly.	Replace with a new ink ribbon cassette. (See page 4-4.)
Faint recording color	The ink ribbon has reached the end of its life.	Replace with a new ink ribbon cassette. (See page 4-4.)
	The ink ribbon is not being taken up.	Press the (FEED) key to make sure that the ink ribbon feed knob turns and is correctly attached. (Note 3)
Recording color periodically faint	The ink ribbon has been left for a long time in an open state, and has partially dried.	Replace with a new ink ribbon cassette. (See page 4-4.)
The chart is not being fed.	The chart is not loaded correctly.	Make sure that the chart holder and chart guide are correctly attached in place. Attach correctly if necessary.
The chart has come away from the sprockets.	The chart is not loaded correctly.	Make sure that the chart holder and chart guide are correctly attached in place. Attach correctly if necessary.

Note 2: If the load lever is stiff and difficult to press down, the chart cassette is not inserted correctly as far as possible.

Note 3: Pulling the ink ribbon out of the ink ribbon cassette with excessive force may damage the components inside the ink ribbon cassette. Slowly turn the ink ribbon feed knob to take up any slack on an ink ribbon that is protruding too much.

Trouble	Probable Cause	Remedy
“ OL” , “ -OL” , “ OF” or “ -OF” is displayed at the PV display on the display.	An excessive voltage is being input.	Make sure that the signal voltage is correct. Enter the correct signal.
		Make sure that the signal voltage is correct. Enter the correct range code.
		Check the polarities of the input terminals, and wire correctly if necessary.
	The wiring or sensor is broken.	Check the wiring from the sensor for breakages. Repair the sensor.
		Check the wiring from the signal oscillator for breakages. Repair the oscillator.
	The sensor or signal generator is malfunctioning.	Make sure that the sensor is not malfunctioning. Repair the sensor.
Make sure that the signal generator is not malfunctioning. Repair the signal generator.		
The input impedance of equipment connected in parallel to the recorder has dropped.	Make sure that the equipment connected in parallel to this recorder is not turned OFF. Turn the parallel-connected equipment ON.	
	Make sure that the equipment connected in parallel to this recorder is not malfunctioning. Repair the parallel-connected equipment.	
PV values using engineering scaling remain fixed values in spite of the input signal.	The engineering range upper limit value is set to the same value as its lower limit value.	Set the correct engineering range. (See page 6-12.)
The PV display shows an error with the actual PV value.	The range code setting does not match the sensor.	Set the correct range code. (See page 6-12.)
	The PV bias is inappropriate.	Set the appropriate PV bias. To disable, set to “ 0” (zero). (See page 6-13.)
Recording is 0% or less or 100% or more even though the PV display is correct.	The scale setting is inappropriate.	Set the scale matched to the input. (See page 6-16.)
	The scale upper limit value is set to the same value as its lower limit value.	Set the correct scale. (See page 6-16.)
Trend is stepped.	The scale span is far smaller than the resolution.	Set the scale as required. (See page 6-16.)

Trouble	Probable Cause	Remedy
Pressing the ENT key in the configuration mode cannot set data.	Configuration is locked.	Cancel configuration lock in the system setup. (See page 6-10.)
	An attempt was made to enter illegal data.	Enter data in the correct entry range.
Pressing the SET key does not enter the range or scale setting mode.	The extended menu ON/OFF setting is OFF.	Set the extended menu ON/OFF setting to ON. (See page 6-10.)
The recorder does not enter the event setting value screen.	The event type setting is set to " event OFF" .	Correct the event type setting. (See page 6-4.)
The setting values of the event relay No. does not light.	The event relay optional function is not supported.	Attach the add-on optional unit if necessary. (See page 1-3.)
	The option unit is malfunctioning.	Repair.
Events are not recorded on the chart.	The event recording ON/OFF setting is set to " event recording OFF" .	Set the event recording ON/OFF setting to " event recording ON." (See page 6-4.)
The event switches ON/OFF continuously.	The event differential is too small.	Set the event differential to the appropriate value. (See page 6-4.)
Characters are not printed on charts.	The chart feed speed is set to 240mm/h.	Set the chart feed speed to 120mm/h or less. (See page 6-6.)
PV values during demand printing or tabulation printing are all printed as "-----" .	The recording mode of all channels is set to " display/recording OFF" .	Set the recording mode for the required channels.
The recorder ID No. is not printed.	The recorder ID No. setting is " 0" .	Set the recorder ID No. to number other than " 0" (zero). (See page 6-10.)
The time is not recorded.	The time recording ON/OFF setting is OFF.	Set the time recording ON/OFF setting to ON. (See page 6-10.)
Scale is not recorded.	The scale recording ON/OFF setting is OFF.	Set the scale recording ON/OFF setting to ON. (See page 6-10.)
The recording color does not match the tag plate.	The recording color selection setting does not match the tag plate.	Match the recording color selection to the tag plate. (See page 6-10.)
		Obtain a tag plate matched to the recording color selection. (See page 1-4.)
Schedule demand is not printed.	The time setting interval is too short and cannot be printed.	Set the time setting to a wider value. (See page 6-11.)
		Decrease the number of demand printing. (See page 6-11.)
		Set the chart feed speed to a higher value. (See page 6-6.)
	The number of schedule demand ON/OFF settings is less than the time setting.	Match the number of schedule demand ON/OFF settings to the number of schedule demand time settings in use.
	The schedule demand printing time is not set to " recording ON" .	Set to the recording ON mode before the schedule demand printing time.

Trouble	Probable Cause	Remedy
The loader cannot be connected.	The cable is disconnected.	Replace the cable.
	Smart Loader Package	Use the correct Loader Package.
CPL communications is not possible.	The device address is set to " 0" .	Set the device address to an appropriate value other than " 0" . (See page 6-10.)
	The communications method of the recorder does not match the setting of the master.	Match the communications method between this recorder and the master.(See page 6-10.)
	Inappropriate communications cable	Use an appropriate cable.
	Incorrect communications wiring	Rewire correctly. (See page 3-6.)
	Incorrect protocol	Change to the appropriate protocol.
Data from the master station cannot be written by CPL communications.	Communications access rights are set to " read only."	Set the communications access rights to " read/write" as necessary. (See page 6-10.)

Chapter 10. SPECIFICATIONS

10 - 1 Specifications

■ General Specifications

Memory protection	Setup data	EEPROM
	Clock backup	Lithium cell: CR2430
Insulation resistance	Min. 20MΩ across each terminal and GND terminal (by 500Vdc megger)	
Dielectric strength	Power supply, event output (leak current 5mA max.):	
	Across power terminal and GND terminal:	1500Vac 50/60Hz for 1min
	Across event output terminal and GND terminal	1500Vac 50/60Hz for 1min
	Input (leak current 2mA max.):	
	Across measurement input terminal and GND terminal:	1000Vac 50/60Hz for 1min
Induction resistance	Common mode rejection rate: 120dB (50/60Hz±0.1Hz, input impedance 500Ω, across terminals and ground)	
	Normal mode rejection rate: 40dB (50/60Hz±0.1Hz)	
	Temperature	23±2°C
	Humidity	60±5%RH
	Voltage fluctuation	±1%
Standard conditions	Frequency fluctuation	±1%
	Vibration, noise, surge voltage	Not allowed
	Influence from other equipment	Not allowed
	Mounting	Horizontal
	Ambient temperature	0 to 50°C
	Ambient humidity	30 to 90%RH (condensation not allowed)
	Power voltage	90 to 250Vac
Operating conditions	Power supply frequency	±5% of rated power frequency
	Vibration resistance	0.98m/s ² (0 to 100Hz)
	Mounting orientation	0 to 30° bottom rear angle from horizontal position, 0 to 3° top rear angle from horizontal position, other directions 10°
	Ambient temperature	-20 to +60°C (-10 to +60°C for ink ribbon. At -20 to -10°C, only ink ribbon must be stored separately.)
	Ambient humidity	5 to 95%RH (condensation not allowed)
	Shock resistance	294m/s ² (continuously for 11ms max.)
Transportation/storage conditions	Vibration resistance	4.9m/s ² max. (0 to 100Hz)
	Rated power voltage	
	100 to 240Vac, 50/60Hz	
	Power consumption	
Approx. 15VA (30VA max.)		
Rush current	Power voltage	Approx. 15A (for 5ms. max.) at 100Vac
		Approx. 24A (for 5ms. max.) at 200Vac
Material	Case	Steel plate
	Door frame	Polycarbonate containing glass fiber (PC-GF10)
	Door window	Acryl (PMMA)
Color	Case	Frosted gray (DIC554 or equivalent)
	Door frame	Surface matte gray (DIC554 or equivalent)
Mass	W/out optional functions	Approx. 3.4kg
	W/ optional functions	Approx. 3.7kg
Mounting	Panel mount	
Conformed standard	EN61010-1, EN50081-2, EN50082-2	
Warm up time	At least 60 minutes	

■ Performance Specifications

Input	Input type	DC voltage -20 to +20mV, -40 to +40mV, -60 to 60mV, -200 to +200mV, -2 to +2V, -5 to +5V, 0 to 10V Thermocouple R,S,B,K,E,J,T,N (JIS C1602-1981) Nicrosil-Nisil (N.B.S Monograph 161) WRe0-26 (ASTM E1751) WRe5-26 (ASTM E988-90) PR40-20 (Johnson Matthey Data) PL II (Engelhard Industries Data (IPTS68)) Ni-NiMo (General Electric Data) Kp-Au7Fe (Gold iron chromel (Hayashidenko Data)) Resistance temperature detector (RTD) Pt100,JPt100 (JIS C1604-1989) Note 1: In the case of DC current (4 to 20mAdc), attach a converter resistor(sold separately, catalog No.81446642-001 or 81401325), and convert to 1 to 5V to input.	
	Number of input channels	6	
	Input measurement cycle	30s/6 points (30s regardless of number of measurement points)	
	Input impedance	DC voltage ($\pm 2V$ range max.), thermocouple input: 10M Ω min.	
		DC voltage ($\pm 5V$ range min.) : 1M Ω min.	
	Allowable wiring resistance	DC voltage, thermocouple input (input wiring resistor): 2k Ω max.	
		RTD input (input wiring resistor) : 10 Ω max. (per line. However, resistance of three lines must be the same.)	
	Burnout	Thermocouple input: one of upscale/downscale OFF can be selected for each channel (burnout condition: 10M Ω min.)	
	Input bias current	DC voltage ($\pm 2V$ range max.), thermocouple input: $\pm 100nA$ max.	
		DC voltage ($\pm 5V$ range min.) : $\pm 1\mu A$ max. However, current must be $\pm 200nA$ max. when setting burnout for thermocouple input.	
	Measuring current	RTD input: Approx. 1mA	
	Permissible input voltage range	Outside RTD range: -7 to +11Vdc	
		RTD range: -5 to +5Vdc	
	PV bias	Can be set to each channel in range -19999 to +29999 Unit (engineering unit including decimal point).	
	Linear scaling	Display and recording is possible at actual unit (engineering unit) at linear scaling range DC voltage (range codes 00 to 06).	
	Direct-reading range	mV or V values can be read directly with linear scaling set to OFF during input voltage direct-reading range and current/voltage (range codes 10 to 16).	
	Measurement/calculation method	PV value, inter-channel deviation, deviation from fixed value	
	Measurement range	DC voltage input: Any measurement range (upper/lower limit values) can be set for each of the measurement ranges.	
	Engineering range	DC voltage input: The engineering range (upper/lower limit value, decimal point position and unit) can be set within the range -19999 to +29999.	
	Recording scale	Any recording scale (including reverse scaling) can be set for each channel within the range -19999 to +29999.	
Reference contact compensation	Thermocouple input: Compensation can be set ON/OFF for all channels (not independently). When compensation is set to OFF, a reference contact compensation unit (such as an ice box) must be provided externally.		
Intrinsically safe explosion-proof system	100V ac is used as the lamp power supply on models with chart illumination lamp. So, an intrinsically safe explosion-proof system cannot be configured. When an intrinsically safe explosion-proof system is required, select a model without the chart illumination lamp, and connect a Zener barrier externally. If uneven resistance from the Zener barrier causes a temperature display error to occur, compensate for this by the PV bias. As the input wiring resistance exceeds 10 Ω , the accuracy compensation on page 10-6 cannot be applied.		
Display	Digital display	Display method	Red and green 7-digit, 7-segment LED and 1 green LED for units (One of these is a 5-digit, green LED for displaying measurement values.)
		Display cycle	4s/measurement point
		Display information	<ul style="list-style-type: none"> • Measurement values • Channel No. • Alarm display • Date • Time (h:min) • Chart feed speed • Other configuration data
	Lamp display	Display information	<ul style="list-style-type: none"> • Lights during recording and event occurrence • Lights and displays configuration and operation mode information

Recorder	Recording method	Dot recording	Wire dot + ink ribbon (6 colors)							
		Dot size	Approx. 0.5mm							
		Trend recording cycle	30s/6 points 30s regardless of number of measurement points. The dot cycle is automatically adjusted when there are few input changes at a chart feed speed of 20mm/h or less so that dots do not overlap.							
		Recording color	Trend	Two types can be selected and set (turn power ON to enable)						
				Channel	1	2	3	4	5	6
				Standard	Purple	Red	Green	Blue	Brown	Black
			DIN	Purple	Red	Black	Green	Blue	Brown	
			Scale	Same color as trend color of each channel						
			Tabulation recording	Same color as trend color of each channel						
			Time printing	PV value: Same color as trend color of each channel Time: Purple						
			Event	Occurrence: red Reset: Blue						
			Channel No.	Same color as trend color of each channel						
			Demand	PV value: Same color as trend color of each channel Time: Purple						
	Message	Purple								
	Other	Purple								
	Character structure	Dot matrix	7 (V) x 5 (H)							
	Character recording	Recording at chart feed speed 120mm/h max.								
	Chart	Shape	Folding type							
		Eff. recording width	-1.0 to +101.0mm of calibration position (0%)							
		Total length	16m (standard paper), 12m (clean paper)							
		Replacement warning mark	Warning marks are output at 10cm intervals from 60cm from the end of the chart.							
		Chart feed speed	2.5, 5, 10, 20, 40, 60, 120, 240mm/h changable							
		Trend recording resolution	0.1m							
Recording accuracy (excluding chart shrinkage/elongation)		PV axis: (Accuracy indicated in page 10-6) + ($\pm 0.5\%$ of recording full scale) $\pm 0.1\%$ max. (when chart is fed continuously for 1000mm or more)								
[Reference]		Chart shrinkage/elongation: When the ambient humidity has changed from 60% to 85%RH: → Chart stretches by approx. 0.7%FS. When the ambient humidity has changed from 60% to 45%RH → Chart shrinks by approx. 0.2%FS.								
Display/recording mode	One of the following three modes can be selected and set for each channel: • Display/recording OFF • Display only • Display/recording ON									

Recording format	Trend recording	Trend	• PV value (analog) • Channel No.																
		Scale printing	• Marker/time (h:min)/date/tag/unit/scale upper- and lower-limit values Or, • Marker/time (h:min)/chart feed speed/tag/unit/scale upper- and lower-limit values																
		Event	• Marker (on trend) • Channel No./time (h:min)/event No./relay No./state (occurrence/reset) When a state occurs (is reset) before printing has finished, the next 24 items are memorized and printed.																
	Trend + tabulation recording	Trend	• PV value (analog) • Channel No.																
		Scale printing	• Marker/time (h:min)/date/tag/unit/scale upper- and lower-limit values Or, • Marker/time (h:min)/chart feed speed/tag/unit/scale upper- and lower-limit values																
		Tabulation	• PV value (printed to left in two rows, three columns. channels 1, 2, and 3 from left on top row, and channels 4, 5 and 6 from left on bottom row) Tabulation is carried out after printing of the scale. • Tabulation Cycle <table border="1" style="margin-left: 20px;"> <tr> <td>Chart feed speed (mm/h)</td> <td>2.5</td> <td>5</td> <td>10</td> <td>20</td> <td>40</td> <td>60</td> <td>120</td> </tr> <tr> <td>Print cycle (time)</td> <td>12</td> <td>12</td> <td>4</td> <td>2</td> <td>1</td> <td>1</td> <td>1</td> </tr> </table>	Chart feed speed (mm/h)	2.5	5	10	20	40	60	120	Print cycle (time)	12	12	4	2	1	1	1
		Chart feed speed (mm/h)	2.5	5	10	20	40	60	120										
	Print cycle (time)	12	12	4	2	1	1	1											
	Event	• Marker (on trend) • Channel No./time (h:min)/event No./relay No./state (occurrence/reset) When a state occurs (is reset) before printing has finished, the next 24 items are memorized and printed.																	
	Trend + schedule demand	Trend	• PV value (analog) • Channel No.																
Scale printing		• Marker/time (h:min)/date/tag/unit/scale upper- and lower-limit values Or, • Marker/time (h:min)/chart feed speed/tag/unit/scale upper- and lower-limit values																	
Schedule demand		• Time (h:min)/PV value (printed to left in two rows, three columns. channels 1, 2, and 3 from left on top row, and channels 4, 5 and 6 from left on bottom row) Up to four times can be set.																	
Event		• Marker (on trend) • Channel No./time (h:min)/event No./relay No./state (occurrence/reset) When a state occurs (is reset) before printing has finished, the next 24 items are memorized and printed.																	
List printing	• Print all lists: • Print specified lists:	All parameters set in the configuration are printed out. Chart feed speed, range code, scale, unit, event setting values, etc.																	
Event	Setting	Number of set events	Four events can be set for each channel.																
		Setting range	-19999 to +29999 (Decimal point position varies according to range.)																
		Differential	0 to 29999 (Decimal point position varies according to range.)																
	Action	Event action is carried out even while recording has stopped (RCD OFF). OFF: Event action stopped LOW (measurement value lower limit alarm): Action when the PV and deviation values are at the event setup value or less HIGH (measurement value upper limit alarm): Action when the PV and deviation values are at the event setup value or more																	
	Action result	Recording	• Channel No. • Event occurrence/reset • Event state • Relay output number (w/ event option)																
		Display	• Event state and measurement value when an event occurs • Event occurrence/reset state on other channels																
		Buffer	• Up to 24 recording actions are memorized. (These are cleared when the power or recording are turned OFF.)																
		Relay output	Optionally supportable as event output																

Optional functions	External switch inputs (RSW)	Number of inputs	4			
		Functions	<p>Functions operate by assigning the following:</p> <ul style="list-style-type: none"> • RSW1: Recording start/stop • RSW2: Print on demand (DMD) • RSW3: Chart feed • RSW4: Print message 1 <p>Above function assignments are fixed on body. However, the following functions can be freely assigned to each external switch input (1 function per 1 RSW) by the Smart Loader Package in addition to the above functions.</p> <ul style="list-style-type: none"> • Print message 2 • Print message 3 • Print message 4 • Chart feed speed/scale selection 			
		Contact hold time	500ms min.			
		Switch type	Dry contact or open collector (current sink to common)			
		Allowable open collector ON residual voltage	0.5V max. (under recommended operating conditions)			
		Allowable open collector OFF leakage current	0.1mA max. (under recommended operating conditions)			
		Open voltage	Approx. 5V			
		Short-circuit current	Approx. 6mA			
	Event outputs	Number of outputs	6			
		Output action	Four event actions (max. 24 actions) preset to each channel can be freely combined to output OR.			
		Output type	Transfer contact (NC, NO contact), Event relay excitation is forward action.			
		Contact rating	250Vac 3A (resistive load) 30Vdc 3A (resistive load) Min. applicable load 5Vdc 100mA, 24Vdc 50mA			
		Electrical life	100,000 operations (resistive load)			
	Chart illumination lamp	Cold cathode fluorescent light				
	Communications	Standard	Standard	RS-232C	RS-485	
			Number of signal lines	3 (including SG)	5 (including SG)	
			Transmission distance	15m max.	300m max.	
		Protocol	Standard	Yamatake Corporation CPL communications	Yamatake Corporation CPL communications	
			Network	1:1	Multi-drop (max. 31 nodes)	
			Function	Slave station function	Slave station function	
Master station			Not specified	Not specified		
Communications system		Synchronization	Start-stop synchronization	Start-stop synchronization		
		Communications flow	Half duplex	Half duplex		
		Transmission speed	4800, 9600bps	4800, 9600bps		
		Data length	8bits	8bits		
		Parity	Even parity, no parity	Even parity, no parity		
	Stop bit	1, 2	1, 2			

10 - 2 Input Types, Ranges and Display Accuracy

Input			Range		Display Accuracy (rdg refers to absolute value of indication value)	Resolution	
Type	Symbol	Code	mV/V input	mV/V indication range			
DC voltage	mV	00	±20mV	-19999 to +29999	± (0.2% of rdg+3 digits)	10µV	
		01	±40mV	-19999 to +29999	± (0.2% of rdg+2 digits)	10µV	
		02	±60mV	-19999 to +29999	± (0.2% of rdg+2 digits)	10µV	
		03	±200mV	-19999 to +29999	± (0.2% of rdg+2 digits)	100µV	
	V	04	±2V	-19999 to +29999	± (0.2% of rdg+2 digits)	1mV	
		05	±5V	-19999 to +29999	± (0.2% of rdg+2 digits)	1mV	
		06	0 to 10V	-19999 to +29999	± (0.2% of rdg+2 digits)	1mV	
	mV	10	±20mV	±20.00mV	± (0.2% of rdg+3 digits)	10µV	
		11	±40mV	±40.00mV	± (0.2% of rdg+2 digits)	10µV	
		12	±60mV	±60.00mV	± (0.2% of rdg+2 digits)	10µV	
		13	±200mV	±200.00mV	± (0.2% of rdg+2 digits)	100µV	
	V	14	±2V	±2.000V	± (0.2% of rdg+2 digits)	1mV	
		15	±5V	±5.000V	± (0.2% of rdg+2 digits)	1mV	
		16	0 to 10V	0 to 10.000V	± (0.2% of rdg+2 digits)	1mV	
	Type	Symbol	Code	°C Range		Display Accuracy	Resolution
	Thermocouple (Note 1)	R	20	0.0 to 1760.0°C	0 to less than 100°C	±3.7°C	0.2°C
S		21	100 to less than 300°C		±1.5°C	0.2°C	
B		22	0.0 to 1820.0°C	300°C min.	± (0.15% of rdg+1°C)	0.2°C	
				Less than 400°C	±50°C	Not specified	
				400 to less than 600°C	±3°C		
K		23	-200.0 to +1370.0°C	600°C min.	± (0.15% of rdg+1°C)	0.2°C	
				-200 to less than -100°C	± (0.15% of rdg+1.5°C)	0.2°C	
				-100°C min.	± (0.15% of rdg+0.9°C)		
E		24	-200.0 to +800.0°C	-200 to less than -100°C	± (0.15% of rdg+1°C)	0.2°C	
				-100°C min.	± (0.15% of rdg+0.6°C)		
J		25	-200.0 to +1100.0°C	-200 to less than -100°C	± (0.15% of rdg+1.1°C)	0.2°C	
				-100°C min.	± (0.15% of rdg+0.7°C)		
T		26	-200.0 to +400.0°C	-200 to less than -100°C	± (0.15% of rdg+1°C)	0.2°C	
				-100°C min.	± (0.15% of rdg+0.6°C)		
Nicrosil-Nisil		27	0.0 to 1300.0°C	Entire range	± (0.15% of rdg+1°C)	0.2°C	
WRe0-26	28	0.0 to 2320.0°C	0 to less than 300°C	± (0.15% of rdg+10°C)	1.1°C		
			300 to less than 600°C	± (0.15% of rdg+1.5°C)			
			600°C min.	± (0.15% of rdg+1°C)			
WRe5-26	29	0.0 to 2320.0°C	0 to less than 300°C	± (0.15% of rdg+1.5°C)	0.2°C		
			300°C min.	± (0.15% of rdg+1°C)			
PR40-20	30	0.0 to 1880.0°C	0 to less than 500°C	±40°C	2.2°C		
			500 to less than 900°C	±12°C			
			900 to less than 1500°C	± (0.3% of rdg+6°C)			
			1500°C min.	± (0.3% of rdg+3.5°C)			
PLII	31	0.0 to 1290.0°C	Entire range	± (0.15% of rdg+0.7°C)	0.2°C		
Ni-Ni•Mo	32	0.0 to 1200.0°C	Entire range	± (0.15% of rdg+0.7°C)	0.2°C		
Kp-Au7Fe	33	0.0 to 300.0K	0 to less than 25K	± (0.3% of rdg +1.6K)	0.2K		
			25K min.	± (0.3% of rdg +1.1K)			
Resistance temperature detector (RTD)	Pt100	40	-200.0 to +550.0°C	Entire range	± (0.15% of rdg+0.6°C)	0.2°C	
	JPt100	41	-200.0 to +550.0 °C	Entire range	± (0.15% of rdg+0.6°C)	0.2°C	

Type	Symbol	Code	°F Range	Display Accuracy	Resolution	
Thermocouple (Note 1)	R	50	32 to 3200°F	32 to less than 212°F	±8°F	1°F
	S	51		212 to less than 572°F	±4°F	1°F
				572°F min.	± (0.15% of rdg+3°F)	1°F
	B	52	32 to 3308°F	Less than 752°F	±90°F	Not specified
				752 to less than 1112°F	±6°F	2°F
				1112°F min.	± (0.15% of rdg+3°F)	1°F
	K	53	-328 to +2498°F	-328 to less than -148°F	± (0.15% of rdg+4°F)	1°F
				-148°F min.	± (0.15% of rdg+3°F)	1°F
	E	54	-328 to +1472°F	-328 to less than -148°F	± (0.15% of rdg+3°F)	1°F
				-148°F min.	± (0.15% of rdg+2°F)	1°F
	J	55	-328 to +2012°F	-328 to less than -148°F	± (0.15% of rdg+3°F)	1°F
				-148°F min.	± (0.15% of rdg+2°F)	1°F
	T	56	-328 to +752°F	-328 to less than -148°F	± (0.15% of rdg+3°F)	1°F
			-148°F min.	± (0.15% of rdg+2°F)	1°F	
	Nicrosil-Nisil	57	32 to 2372°F	Entire range	± (0.15% of rdg+3°F)	1°F
	WRe0-26	58	32 to 4208°F	32 to less than 572°F	± (0.15% of rdg+19°F)	3°F
				572 to less than 1112°F	± (0.15% of rdg+4°F)	1°F
				1112°F min.	± (0.15% of rdg+3°F)	1°F
	WRe5-26	59	32 to 4208°F	32 to less than 572°F	± (0.15% of rdg+4°F)	1°F
				572°F min.	± (0.15% of rdg+3°F)	1°F
	PR40-20	60	32 to 3416°F	32 to less than 932°F	±73°F	5°F
				932 to less than 1652°F	±32°F	2°F
				1652 to less than 2732°F	± (0.3% of rdg+12°F)	2°F
				2732°F min.	± (0.3% of rdg+7°F)	1°F
	PLII	61	32 to 2354°F	Entire range	± (0.15% of rdg+2°F)	1°F
	Ni-Ni•Mo	62	32 to 2192°F	Entire range	± (0.15% of rdg+2°F)	1°F
Resistance temperature detector (RTD)	Pt100	70	328.0 to 1202.0 °F	Entire range	± (0.15% of rdg+1.2°F)	0.5°F
	JPt100	71	328.0 to 1022.0°F	Entire range	± (0.15% of rdg+1.2°F)	0.5°F

(Note 1) Display accuracy does not include reference contact compensation accuracy.

The final display accuracy, when reference contact compensation is ON (factory setting), is obtained by adding the following reference contact compensation accuracy to the display accuracy in the tables.

Reference contact compensation accuracy

- Type: K, E, J, T, Ni-Ni•Mo, PLII, Nicrosil-Nisil: ±0.5°C/±1°F

Note that the reference contact compensation accuracy is as follows at low temperatures:

At K, E, J, T input -100°C/-148°F or less: ±1°C/±2°F

- Type: Kp-Au7Fe: ±0.5K

Note that the reference contact compensation accuracy is as follows at low temperatures:

At 25K or less: ±1K

- Type: R, S, B, WRe0-26, WRe5-26: ±1°C/±2°F
- Type: PR40-20: ±2°C/±4°F

10 - 3 External Dimensions

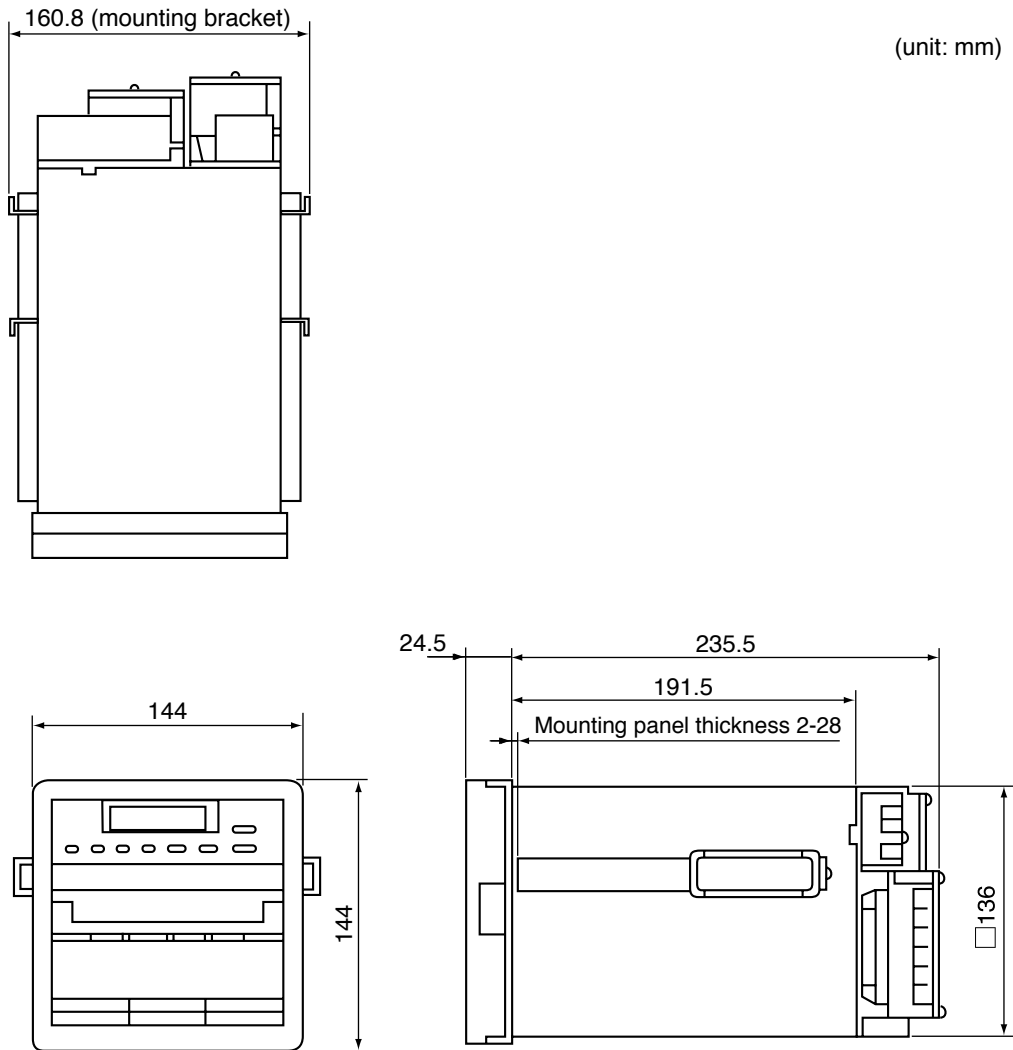

APPENDICES

■ Appendix Contents

- General Setup Appendix-2
- Range Setup Appendix-4
- Scale Setup Appendix-4
- Event Setup Appendix-6

■ How to Use the Setup Sheets

The left page shows the setup details, and the right page shows the fields for entering the setting values. You might find it easier to make copies with both pages folded out.

APPENDICES

Customer	
Device Name	
Mfg. No.	

■ Setup Details

Display No.	Setup Item	Setup description	Factory Setting
1	Configuration lock	0 (OFF)/1 (ON)	0 (OFF)
2	List printing	0 (stop)/1 (partial)/2 (entire)	0 (stop)
3	Extended menu entry	0 (OFF)/1 (ON)	0 (OFF)
4	Recording format selection	1 (trend)/2 (trend + tabulation)/ 3 (trend + schedule demand)	2 (trend + tabulation)
5	Recorder ID No.	0 to 99	0
6	Recording time ON/OFF	0 (OFF)/1 (ON)	1 (ON)
7	Scale recording ON/OFF	0 (OFF)/1 (ON)	1 (ON)
8	Recording color selection (STD/DIN)	1 (STD)/2 (DIN)	1 (STD)
9	Communications access rights selection	1 (read)/2 (read/write)	2 (read/write)
A	Device address	0 to 127 (setting to " 0" inhibits communications)	0
	Communications method	1: 4800bps, 8bits even parity, 1 stop bit 2: 4800bps, 8bits no parity, 2 stop bits 3: 9600bps, 8bits even parity, 1 stop bit 4: 9600bps, 8bits no parity, 2 stop bits	1 (OFF)
B	Schedule demand ON/OFF	0: Printing to all set times (OFF) 1: Tabulation printing at No.1 time (# 1) 2: Tabulation printing at No.1 and No.2 times (# 1, 2) 3: Tabulation printing at No.1, No.2 and No.3 times (# 1, 2, 3) 4: Tabulation printing at No.1, No.2, No.3 and No.4 times (# 1, 2, 3, 4)	0 (OFF)
C	No.1 schedule demand time	0:00 to 23:59	00:00
D	No.2 schedule demand time	0:00 to 23:59	00:00
E	No.3 schedule demand time	0:00 to 23:59	00:00
F	No.4 schedule demand time	0:00 to 23:59	00:00

Display No.	Setup Item	Setup Description	Factory Setting
1	No.1 chart feed speed No.	2.5/5/10/20/40/60/120/240	4 (20)
2	No.2 chart feed speed No.	2.5/5/10/20/40/60/120/240	4 (20)

Setup Item	Setup Description	Factory Setting
Date		Close to Japan standard time
Time (h:min)		

Model No.	
Prepared by	
Date Prepared	

■ User Setup Field

Display No.	Check	Setup Item	User Setup Field
1		Configuration lock	
2		List printing	
3		Extended menu entry	
4		Recording format selection	
5		Recorder ID No.	
6		Recording time ON/OFF (1)	
7		Scale recording ON/OFF	
8		Recording color selection (STD/DIN)	
9		Communications access rights selection	
A		Device address	
		Communications method	
B		Schedule demand ON/OFF	
C		No.1 schedule demand time	
D		No.2 schedule demand time	
E		No.3 schedule demand time	
F		No.4 schedule demand time	

Display No.	Check	Setup Item	User Setup Field
1		No.1 chart feed speed No.	
2		No.2 chart feed speed No.	

Check	Setup Item	User Setup Field
	Date	
	Time (h:min)	

APPENDICES

Customer	
Device Name	
Mfg. No.	

■ Setup Details

Range Setup

Display No.	Setup Item	Setup Description	Factory Setting (all channels)
1	Recording mode selection	0 (OFF)/1 (display)/2 (display + recording)	2
2	Range code	Selectable from all codes	05 ($\pm 5V$)
3	Input calculation type	1 (PV)/ 2 (reference channel-current channel)/ 3 (current channel-reference channel)/ 4 (fixed value-current channel)/ 5 (current channel-fixed value)	1
4	Reference channel	1 to 6	1
5	Burnout selection	0 (OFF)/1 (UP)/2 (DOWN)	0 (OFF)
6	Measurement range lower limit	-19999 to +29999	1
7	Measurement range upper limit	-19999 to +29999	5
8	Engineering range decimal point	0 (xxxxx) to 4 (x.xxxx)	1 (xxxx.x)
9	Engineering range lower limit	-19999 to +29999	0
A	Engineering range upper limit	-19999 to +29999	100
B	Fixed value for deviation	-19999 to +29999	0
C	PV bias	-19999 to +29999	0
D	Engineering unit setting (UNIT)	1st character	20 (blank)
		2nd character	20 (blank)
		3rd character	20 (blank)
		4th character	20 (blank)
		5th character	20 (blank)
		6th character	20 (blank)
E	Input tag name setting (TAG)	1st character	43 (C)
		2nd character	48 (H)
		3rd character	31 (1) to 36 (6)
		4th character	
		5th character	

Scale Setup

Display No.	Setup Item	Setup Description	Factory Setting (all channels)
1	No.1 scale lower limit	-19999 to +29999	0
2	No.1 scale upper limit	-19999 to +29999	100
3	Scale switching method selection	0 (OFF)/1 (auto)/2 (RSW or communications)	0
4	No.2 scale lower limit	-19999 to +29999	0
5	No.2 scale upper limit	-19999 to +29999	100
6	Auto-switching point	-19999 to +29999	0
7	Auto-switching differential	0 to 29999	0

Model No.	
Prepared by	
Date Prepared	

■ User Setup Field

Range Setup

Display No.	Check	Setup Item	Channel					
			1	2	3	4	5	6
1		Recording mode selection						
2		Range code						
3		Input calculation type						
4		Reference channel						
5		Burnout selection						
6		Measurement range lower limit						
7		Measurement range upper limit						
8		Engineering range decimal point						
9		Engineering range lower limit						
A		Engineering range upper limit						
B		Fixed value for deviation						
C		PV bias						
D		Engineering unit setting (UNIT)						
E		Input tag name setting (TAG)						

Scale Setup

Display No.	Check	Setup Item	Channel					
			1	2	3	4	5	6
1		No.1 scale lower limit						
2		No.1 scale upper limit						
3		Scale switching method selection						
4		No.2 scale lower limit						
5		No.2 scale upper limit						
6		Auto-switching point						
7		Auto-switching differential						

APPENDICES

Customer	
Device Name	
Mfg. No.	

■ Setup Details

Event Setup

Display No.	Setup Item	Setup Description	Factory Setting (all channels)
1	No.1 event setting value	-19999 to +29999	0
2	No.2 event setting value	-19999 to +29999	0
3	No.3 event setting value	-19999 to +29999	0
4	No.4 event setting value	-19999 to +29999	0
5	No.1 event type selection	0 (OFF)/1 (LOW)/2 (HIGH)	0 (-): OFF
6	No.2 event type selection	0 (OFF)/1 (LOW)/2 (HIGH)	0 (-): OFF
7	No.3 event type selection	0 (OFF)/1 (LOW)/2 (HIGH)	0 (-): OFF
8	No.4 event type selection	0 (OFF)/1 (LOW)/2 (HIGH)	0 (-): OFF
5	No.1 event output relay No.	0 to 6	0
6	No.2 event output relay No.	0 to 6	0
7	No.3 event output relay No.	0 to 6	0
8	No.4 event output relay No.	0 to 6	0
5	No.1 event recording ON/OFF	0 (OFF)/1 (ON)	1 (ON)
6	No.2 event recording ON/OFF	0 (OFF)/1 (ON)	1 (ON)
7	No.3 event recording ON/OFF	0 (OFF)/1 (ON)	1 (ON)
8	No.4 event recording ON/OFF	0 (OFF)/1 (ON)	1 (ON)
9	No.1 event differential	0 to 29999	0
A	No.2 event differential	0 to 29999	0
B	No.3 event differential	0 to 29999	0
C	No.4 event differential	0 to 29999	0

Model No.	
Prepared by	
Date Prepared	

■ User Setup Field

Event Setup

Display No.	Check	Setup Item	Channel					
			1	2	3	4	5	6
1		No.1 event setting value						
2		No.2 event setting value						
3		No.3 event setting value						
4		No.4 event setting value						
5		No.1 event type selection						
6		No.2 event type selection						
7		No.3 event type selection						
8		No.4 event type selection						
5		No.1 event output relay No.						
6		No.2 event output relay No.						
7		No.3 event output relay No.						
8		No.4 event output relay No.						
5		No.1 event recording ON/OFF						
6		No.2 event recording ON/OFF						
7		No.3 event recording ON/OFF						
8		No.4 event recording ON/OFF						
9		No.1 event differential						
A		No.2 event differential						
B		No.3 event differential						
C		No.4 event differential						

Revision History

Printed Date	Manual Number	Edition	Revised pages	Description
94-12	CP-UM-1666E	1st Edition		
99-12		4th Edition		Overall revision
00-09		5th Edition	v 1-3 2-1 3-10 6-3, App.-4 6-22	Standard folding chart to Folding chart was changed. Smart Loader Package SLP-F10/F20 Manual No.CP-UM-5067E added Folding chart (Recycled paper) added. Smart Handy Loader (SLP-F10) to Smart Loader Package (SLP-F10) was changed. Connection example was changed. Cable model No. was changed and Adapter model No. added. Display No.3 of Range Setup:RNG 4(fixed channel-current channel)/ to 4(fixed value-current channel)/ was changed. 5(current channel-fixed channel)/ to 5(current channel-fixed value)/ was changed. MSG No. of Print message was changed.
01-02		6th Edition	1-2 2-1 3-7 3-9	Cross connection cable for RS-232S interface added. Input terminal→Analog input terminal unit Handling Precautions added. Deleted description of CMA50A105.
02-02		7th Edition		Fonts changed.
02-09		8th Edition	10-1	RESTRICTIONS ON USE changed. Conformed standard added.
03-02		9th Edition		RESTRICTIONS ON USE changed.
04-05		10th Edition	1-3 3-4 3-10	Folding chart 40, 60, 70, 75 section and folding chart (Recycled paper) 50 section model No. changed. Description of Recommended Crimped Terminal changed. Adapter model No. 81408811-001 deleted.
04-10		11th Edition	1-3 10-1 10-2	● Optional Parts: Add-on optional unit RS-232C added. Weight to Mass changed. Warm up time added. Input type changed.

YAMATAKE

Yamatake Corporation
Advanced Automation Company

Totate International Building
2-12-19 Shibuya Shibuya-ku
Tokyo 150-8316 Japan
URL: <http://www.yamatake.com>

This has been printed on recycled paper. (02)

Specifications are subject to change without notice.

Printed in Japan.
1st Edition: Issued in Dec., 1994(W)
11th Edition: Issued in Oct., 2004(W)