

Pen Printing Model Smart Recorder SRF201/202/203

User's Manual Installation/Operation



Thank you for purchasing the Smart Recorder SRF201/202/203 pen printing model.

This manual contains information for ensuring correct use of the Smart Recorder SRF201/202/203 dot printing model. It also provides necessary information for installation, maintenance, and troubleshooting. This manual should be read by those who design and maintain devices that use the Smart Recorder SRF201/202/203 dot printing model. Be sure to keep this manual nearby for handy reference.

Yamatake Corporation

RESTRICTIONS ON USE

When using this product in applications that require particular safety or when using this product in important facilities, pay attention to the safety of the overall system and equipment. For example, install fail-safe mechanisms, carry out redundancy checks and periodic inspections, and adopt other appropriate safety measures as required.

REQUEST

Make sure that this Instruction Manual is handed over to the user before the product is used.

Copying or duplicating this Instruction Manual in part or in whole is forbidden. The information and specifications in this Instruction Manual are subject to change without notice.

Considerable effort has been made to ensure that this Instruction Manual is free from inaccuracies and omissions.

If you should find any inaccuracies or omissions, please contact Yamatake Corporation.

In no event is Yamatake Corporation liable to anyone for any indirect, special or consequential damages as a result of using this product.

©1998 Yamatake Corporation ALL RIGHTS RESERVED

Smart Recorder SRF201/202/203 and Smart Handy Loader SHL100 are trademarks of Yamatake Corporation.

Kim Wipe® is a registered trademark of Crecia Co., Ltd.

SAFETY PRECAUTIONS

■ About Icons

Safety precautions are for ensuring safe and correct use of this product, and for preventing injury to the operator and other people or damage to property. You must observe these safety precautions. The safety precautions described in this manual are indicated by various icons.

The following describes the icons and their meanings. Be sure to read and understand the following descriptions before reading this manual.



WARNING

Warnings are indicated when mishandling of this product might result in death or serious injury to the user.













CAUTION

Cautions are indicated when mishandling of this product might result in minor injury to the user, or only physical damage to this product.













■ Examples

	<p>Triangles warn the user of a possible danger that may be caused by wrongful operation or misuse of this product.</p> <p>These icons graphically represent the actual danger. (The example on the left warns the user of the danger of electrical shock.)</p>
	<p>White circles with a diagonal bar notify the user that specific actions are prohibited to prevent possible danger.</p> <p>These icons graphically represent the actual prohibited action. (The example on the left notifies the user that disassembly is prohibited.)</p>
	<p>Black filled-in circles instruct the user to carry out a specific obligatory action to prevent possible danger.</p> <p>These icons graphically represent the actual action to be carried out. (The example on the left instructs the user to remove the plug from the outlet.)</p>

WARNING

	Do not remove the power supply unit. High-voltage parts are located inside. Touching these parts might result in electric shock.
	Before removing/mounting or wiring the SRF201/202/203, be sure to turn the source power OFF. Touching electrically charged parts on the SRF201/202/203 such as terminals by mistake might cause electric shock.
	Be sure to turn the power source OFF before mounting the SRF201/202/203. Failure to do so might result in electric shock due to a high power supply voltage.
	Before connecting the SRF201/202/203 to the measurement target or external control circuits, make sure that a protective ground terminal is connected to the SRF201/202/203. Failure to do so might cause electric shock or fire.
	The black-headed screw on the right of the main unit is for ground protection. Never remove this screw. Doing so might cause electric shock.
	To prevent danger before you replace the clock backup battery, turn the power OFF, and disconnect the SRF201/202/203 from its power supply.
	Be sure to turn the power source OFF before wiring the SRF201/202/203. Failure to do so might result in electric shock due to a high power supply voltage.
	Power is sometimes supplied to the event wiring even if the SRF201/202/203 is turned OFF. Wire with the power source supply to the event wiring turned OFF. Failure to do so might cause electric shock due to a high power supply voltage.
	After wiring the leads to terminals, do not allow lead clippings to fall into mounting bracket holes or ventilation holes. Failure to do so might cause internal circuits to short-circuit or cause a fire.
	Before you start wiring, check the model No. of the SRF201/202/203 (including operational functions), and wire to the correct terminals. When you have finished wiring, check the numbers again. Wiring the wrong lead to the wrong terminal might damage the main unit or cause a fire.
	Be sure to attach the terminal cover after wiring the SRF201/202/203. Failure to do so might cause electric shock. If you have lost the terminal cover, adopt an equivalent measure, or obtain and attach a maintenance part.

CAUTION

	<p>Wire the SRF201/202/203 according to predetermined standards. Also wire the SRF201/202/203 using designated power leads according to recognized installation methods.</p> <p>Failure to do might cause electric shock, fire or faulty operation.</p>
	<p>Use the SRF201/202/203 within the operating ranges recommended in the specifications (temperature, humidity, voltage, vibration, shock, atmosphere, etc.). Failure to do so might cause faulty operation.</p>
	<p>Do not block ventilation holes.</p> <p>Doing so might cause faulty operation.</p>
	<p>Do not disassemble the SRF201/202/203, nor touch components inside the SRF201/202/203.</p> <p>Doing so might cause electric shock or faulty operation.</p>
	<p>Do not touch hot internal components during use or immediately after turning the power OFF.</p> <p>Doing so might cause burns.</p>
	<p>Do not touch moving parts during operation.</p> <p>Doing so might cause injury.</p>
	<p>Do not operate the keys with the tip of a propelling pencil or sharp-tipped object.</p> <p>Doing so might cause faulty operation.</p>
	<p>Do not use unused terminals on the SRF201/202/203 as relay terminals.</p>
	<p>Use crimped solderless terminals that fit on each terminal screws.</p> <p>For details, see “■ Recommended Crimped Terminal” on page 3-4.</p>
	<p>Adopt sufficient noise countermeasures to prevent malfunction caused by electrical noise.</p>
	<p>Maintain a distance of at least 50 cm between input signal leads and power leads of 100 V or more. Also, do not pass these leads through the same piping or wiring duct.</p>
	<p>Tighten the mounting fixture while pushing in firmly to prevent a gap with the panel.</p> <p>If a gap forms with the panel, the SRF201/202/203 might fall or become loose which is dangerous.</p>

Unpacking

■ Check the Model No.

Check the model No. to make sure that you have received the product that you ordered. The model No. for this product is listed at two places: on the top side of the case and on the right side of the chassis.

For details of names and parts, see “**Chapter 2, Names and Functions of Parts**”(page 2-1).

For details on how to check the model No., see “**1-2 Model Selection Guide**”(page 1-3).

■ Check the Contents of the Package to Make Sure That All Accessories Are Included in The Package

Name		Q'ty	Remarks
Body		1	
Standard folding chart (100-sections)		1	
No.1 pen (red)		1	
No.2 pen (green)		1	2-pen, 3-pen models
No.3 (blue)		1	3-pen model
Printing pen (purple)		1	
Mounting bracket set		1	
Tag No. plate		1	
Terminal screw (spare)		5	
Lubricating oil		1	
User's Manual	Installation/Operation	1	This manual
	DigitroniK CPL communications manual	1	* Packaged only with models that support the communications function.
	SRF100/SRF200 Pen Printing Model Version		

The Role of This Manual

In all, two manuals have been prepared for the SRF201/202/203. Read the manual according to your specific requirements. This manual is the SRF201/202/203 User's Manual. The following lists all the manuals that accompany the SRF201/202/203 and gives a brief outline of the manual. If you do not have the required manual, contact Yamatake Corporation or your dealer.

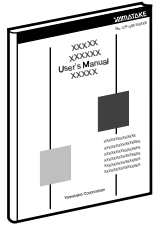
	<p>Installation/Operation Manual No.CP-SP-1037E</p> <p>This manual.</p> <p>This manual is required reading for those who use the SRF201/202/203, those who design hardware for integrating the SRF201/202/203 into operator control panels, those who carry out maintenance, and those who operate instruments in which the SRF201/202/203 is integrated.</p> <p>It describes how to install and wire the SRF201/202/203 for integrating into instruments, method of operation, maintenance and inspection, troubleshooting, and hardware specifications.</p>
---	--

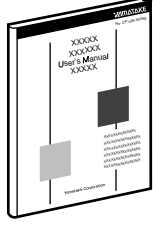
	<p>Digitronik CPL Communications Manual SRF100/SRF200 Pen Printing Model Version Manual No.CP-UM-1668E</p> <p>The SRF201/202/203 can communicate with other equipment via the RS-485 or RS-232C interfaces.</p> <p>This manual describes communications procedures and commands when the SRF201/202/203's communications features supported by SRF200 pen printing models are used. This manual is shared with the SRF100.</p>
---	--

Organization of This User's Manual

This manual is organized as follows.

Chapter 1. INTRODUCTION

This chapter describes SRF201/202/203 applications and features, and gives a list of catalog numbers.

Chapter 2. NAMES & FUNCTIONS OF PARTS

This chapter describes the names and functions of parts on the SRF201/202/203.

Chapter 3. INSTALLATION & WIRING

This chapter describes precautions, siting conditions and installation method when installing the SRF201/202/203 into instruments, and how to connect to peripheral equipment.

Chapter 4. PREPARATION & OPERATION

This chapter describes checks to carry out before operating the SRF201/202/203 and daily operation procedures.

Chapter 5. BASIC CONFIGURATION

This chapter describes the basic setup details of the SRF201/202/203.

Chapter 6. DETAILED CONFIGURATION

This chapter describes all items that can be set using the operation keys.

Chapter 7. MAINTENANCE

This chapter describes inspection items and how to replace maintenance parts to ensure prolonged use of the SRF201/202/203.

Chapter 8. TROUBLESHOOTING

This chapter describes points to check when the SRF201/202/203 is not working properly and how to remedy trouble that might occur.

Chapter 9. SPECIFICATIONS

This chapter describes the general specifications, performance specifications and external dimensions of the SRF201/202/203.

Appendices

These appendices provide you with tables for entering user setting values to the various setups.

Index

Contents

SAFETY PRECAUTIONS

Unpacking

The Role of This Manual

Organization of This User's Manual

Conventions Used in This Manual

Chapter 1. INTRODUCTION

1-1 Applications and Features	1-1
■ Features	1-1
■ Optional Functions	1-2
1-2 Model Selection Guide	1-3
■ Model Listing	1-3
■ Related Parts Model Listing	1-3

Chapter 2. NAMES & FUNCTIONS OF PARTS

2-1 Main Unit	2-1
■ Front Panel	2-1
■ Inside	2-1
■ Rear Terminal Plate	2-2
2-2 Display Setup Unit	2-3
■ Operation Display and Operation Keys	2-3
■ Configuration Unit and Operation Keys	2-4

Chapter 3. INSTALLATION & WIRING

3-1 Installation Site	3-1
3-2 Installation	3-2
■ Installation Dimensions	3-2
■ Installation Procedure	3-2
3-3 Wiring Precautions	3-3
■ Noise Countermeasures	3-4
■ Recommended Crimped Terminal	3-4
3-4 Connecting the Power Supply and Ground	3-5
3-5 I/O Signal Leads	3-6
■ Input Terminals	3-7
■ Wiring Relay Outputs (optional function)	3-7
■ Wiring External Switch Inputs (optional function)	3-7
3-6 Connecting the RS-485 Interface (optional function)	3-8
3-7 Connecting the RS-232C Interface (optional function)	3-9

Chapter 4. PREPARATION & OPERATION

4-1	Loading the Chart	.4-1
■	Loading (replacing) the Chart	.4-1
4-2	Loading (replacing) the Trend Pen and Printing Pen	.4-4
4-3	Operation	.4-6
■	Turning the Power ON	.4-6
■	Starting/stopping Recording	.4-6
■	Feeding the Chart	.4-7
■	Selecting the Display Mode	.4-7
■	Recording a Specific Table	.4-8
■	Other Displays and Operations	.4-9
■	Printout Details	.4-10

Chapter 5. BASIC CONFIGURATION

5-1	Introduction	.5-1
5-2	Basic Key Operations at Setup, Key Lock and Extended Menu	.5-2
■	Basic Key Operations at Setup	.5-2
■	Canceling Configuration Lock	.5-3
■	Switching the Extended Menu ON/OFF	.5-3
5-3	Changing Event Setting Values	.5-4
5-4	Changing the Chart Feed Speed	.5-5
■	Chart Feed Speed and Tabulation Recording Interval	.5-5
5-5	Changing the Date/Time	.5-6

Chapter 6. DETAILED CONFIGURATION

6-1	Introduction	.6-1
6-2	Configuration Data and Factory Settings	.6-2
■	Event Setup (individual channels): EVNT	.6-2
■	Chart Feed Speed Setup: SPD	.6-2
■	Date/Time Setup: CLK	.6-2
■	System Setup 1 (individual channels): SYS	.6-2
■	System Setup 2 (individual channels): SYS	.6-3
■	System Setup 3 (individual channels): SYS	.6-3
6-3	Event Setup	.6-4
■	Event Setup	.6-4
■	Description of Event Setup Items	.6-5
6-4	Chart Feed Speed Setup	.6-7
■	Chart Feed Speed Setup	.6-7
■	Description of Chart Feed Speed Setup Items	.6-7
6-5	Date/Time Setup	.6-8
■	Date/Time Setup	.6-8
6-6	System Setup 1 (Basic Setup)	.6-9
■	System Setup 1	.6-9
■	Description of System Setup 1 Items	.6-10

6-7	System Setup 2 (Range Setup)	.6-12
■	System Setup 2	.6-12
■	Description of System Setup 2 (Range Setup) Items	.6-13
6-8	System Setup 3 (Scale Setup)	.6-15
■	System Setup 3	.6-15
■	Description of System Setup 3 Items	.6-15
6-9	Range Code Table	.6-17
6-10	Character Code Table	.6-19
6-11	External Switch Inputs (Optional Function)	.6-20
6-12	Printing of Messages	.6-21
6-13	About Digital Printing Priority	.6-22
■	Printing Control during a Print Conflict	.6-22
■	Simultaneous Printing Control	.6-22

Chapter 7. MAINTENANCE

7-1	Periodic Inspection	.7-1
7-2	Measuring the Display Accuracy of Analog Inputs	.7-2
■	Equipment Required for Measurement	.7-2
■	Measurement Environment	.7-2
■	Procedure	.7-2

Chapter 8. TROUBLESHOOTING

8-1	Error Displays and Descriptions of Errors	.8-1
8-2	Remedying Trouble	.8-2

Chapter 9. SPECIFICATIONS

9-1	Specifications	.9-1
■	General Specifications	.9-1
■	Performance Specifications	.9-2
9-2	Input Types, Ranges and Display Accuracy	.9-5
9-3	External Dimensions	.9-7

Appendices

User Setup Sheets

●	Event Setup	.Appendix-2
●	Chart Feed Speed Setup	.Appendix-2
●	Date/Time Setup	.Appendix-2
●	System Setup 1	.Appendix-4
●	System Setup 2	.Appendix-4
●	System Setup 3	.Appendix-6

Conventions Used in This Manual

The following conventions are used in this manual.



Handling Precautions

: Handling Precautions indicate items that the user should pay attention to when handling the SRF201/202/203.



Note

: Notes indicate useful information that the user might benefit by knowing.

: Circled or bracketed numbers indicate steps in a sequence or indicate corresponding parts in an explanation.



key

: These icons represent operation keys and setup keys on the setup display.



key



: These indicate 7-segment indications on the data display.



: This indicates the resulting state of the SRF201/202/203 after an operation.

Chapter 1. INTRODUCTION

1 - 1 Applications and Features

This multi-input, 1 to 3 pen printing type, high-function recorder accommodates 180 mm wide charts. The SRF201/202/203 offers the dual features of functions and operating ease as a recorder for various equipment and instrumentation.

It also supports relay output, external switch inputs and communications as optional functions.

■ Features

- One of the following two groups is specified to each channel as the input type according to the model No. The input type can be changed freely within that group.
 - Thermocouple/DC voltage (mV, V) group
 - Resistance temperature detector (RTD)/DC voltage (mV, V) group
- Three recording formats are provided and can be freely selected:
 - Trend recording
 - Trend + tabulation recording
 - Trend + schedule demand recording
- Three measurement methods are provided and can be selected to each channel:
 - Measurement value (PV value)
 - Deviation value between channels
 - Deviation value from fixed value
- Free power supply allows use anywhere:
100 to 240V ac, 50/60 Hz
- Wide range of printing functions:
 - Measurement value (PV value)
 - Channel No.
 - Tag (6 characters per channel)
 - Engineering unit (6 characters per channel)
 - Recording scale (2 types, upper/lower limit values)
 - Chart feed speed
 - Event status (details, time of occurrence/restoration)
 - Time marker
 - Date
 - Time (hours:minutes)
- Printing at the following start conditions is possible:
 - Date
 - Time (hours:minutes)
 - Recording format
 - Chart feed speed
 - Recorder ID No.
- Demand printing also is possible.
Printing is started by the **DMD** key or external switch input (option), and time (hours:minutes) and measurement values (PV values) are printed.
- When trend + schedule demand recording is selected as the recording format, the measurement value (PV value) of up to four preset times can automatically be printed.
- Messages (six characters each for up to four messages) can be printed together with time (hours:minutes) data by the remote switch.

- Event occurrence and reset are printed together with time (hours:minutes) data.
- Printing of “Date/Time (hours:minutes)”, “Scale” and “Event” can be disabled.
- Setup data is protected in EEPROM when the power is OFF.
- Pen phase synchronization is provided in the standard specification.
For details, see “● **About pen phase synchronization**” (page 6-10).

■ Optional Functions

The following optional functions are available:

- Relay outputs
6 outputs: SPDT relay output
- External switch inputs (remote switch input)
4 inputs: recording ON/OFF, Demand printing, Chart feed, Print messages No.1 to No.4.
- Communications
RS-485, RS-232C

1 - 2 Model Selection Guide

■ Model Listing

Basic model No.	Power	Input code	Option 1	Option 2	Option 3	Addition 1	Addition 2	Specifications
SRF201								180 mm 1 pen
SRF202								180 mm 2 pens
SRF203								180 mm 3 pens
	A							100 to 240V ac, 50/60 Hz
		A to F						Semi multi-input (standard specification)*
			0					None
			1					Relay outputs (6)
			2					Relay outputs (6) + external switch inputs (4)
				0				Communications not supported
				1				RS-485
				2				RS-232C
					0			None
						0		None
						D		Inspection certificate provided
						T		Tropical treatment
						B		Tropical treatment + Inspection certificate provided
						Y		Traceability certificate provided
							0	None
							Z	Factory configuration service

* Semi multi-input

	Input code	SRF201		SRF202		SRF203	
		No.1 Pen		No.2 Pen		No.3 Pen	
		T/C, mV, V	RTD, mV, V	T/C, mV, V	RTD, mV, V	T/C, mV, V	RTD, mV, V
SRF201	A						
	B						
SRF202	C						
	D						
SRF203	E						
	F						

■ Related Parts Model Listing

● Accessories

Name/Specification	SRF201	SRF202	SRF203
Standard folding chart (1)			
No.1 pen (red 1)			
No.2 pen (green 1)	—		
No.3 pen (blue 1)	—	—	
Printing pen (purple 1)			
Mounting bracket (1 set)			
Tag No. plate (1)			
Terminal screw (spare 5)			
Lubricating oil (1)			
User's Manual (1)			
CPL Communications Instruction Manual* (1)			

* The CPL Communications Instruction Manual is packaged only with models that support CPL communications function.

● **Consumables (sold separately)**

Name/Specification	Model No.	Remarks
Standard folding chart	81407861-001	10 packets, 100-sections
Folding chart	81407861-002	10 packets, 120-sections
Folding chart	81407861-003	10 packets, 140-sections
Folding chart	81407861-004	10 packets, 80-sections
Folding chart	81407861-005	10 packets, 150-sections
Clean paper chart	81407937-001	10 packets, 100-sections
Spare 1st pens	81446632-001	Red 3
Spare 2nd pens	81446633-001	Green 3
Spare 3rd pens	81446634-001	Blue 3
Spare plotter pens	81446296-001	Purple 3
Lubricating oil	81446513-001	

● **Optional Parts (sold separately)**

Name/Specification	Model No.	Remarks
250 Ω resistor	81401325	Accuracy $\pm 0.02\%$, 1 p'ce
250 Ω resistor	81446642-001	Accuracy $\pm 0.05\%$, 2 p'ces
DC divider input	81446627-001	1/1000 voltage divider resistance
RS-232C cross cable	CBL-RS232Z08	1
Analog scale plate		Contact your dealer.

● **Maintenance Parts (sold separately)**

Name/Specification	Model No.	Remarks
Standard tag plate	81446639-001	10 p'ces
Mounting bracket (1 set)	81446641-001	1 set (2 brackets)
Replacement door	81446635-001	W/pin and spring
Chart cassette	81446636-001	Unit ass'y component
Chart holder	81446637-001	Plastic formed component /stainless steel component
Chart guide	81446638-001	Plastic formed component (transparent)
Power terminal cover	81446504-001	
Analog input terminal cover	81446505-001	
External switch input terminal cover/Communications terminal cover	81446652-001	
Relay output terminal cover	81446508-001	
Terminal screw	81446511-001	2 types, 10 p'ces
Power cable	81446475-001	

Chapter 2. NAMES AND FUNCTIONS OF PARTS

2 - 1 Main Unit

⚠ WARNING

Do not remove the power supply unit.
High-voltage parts are located inside. Touching these parts might result in electric shock.

■ Front Panel

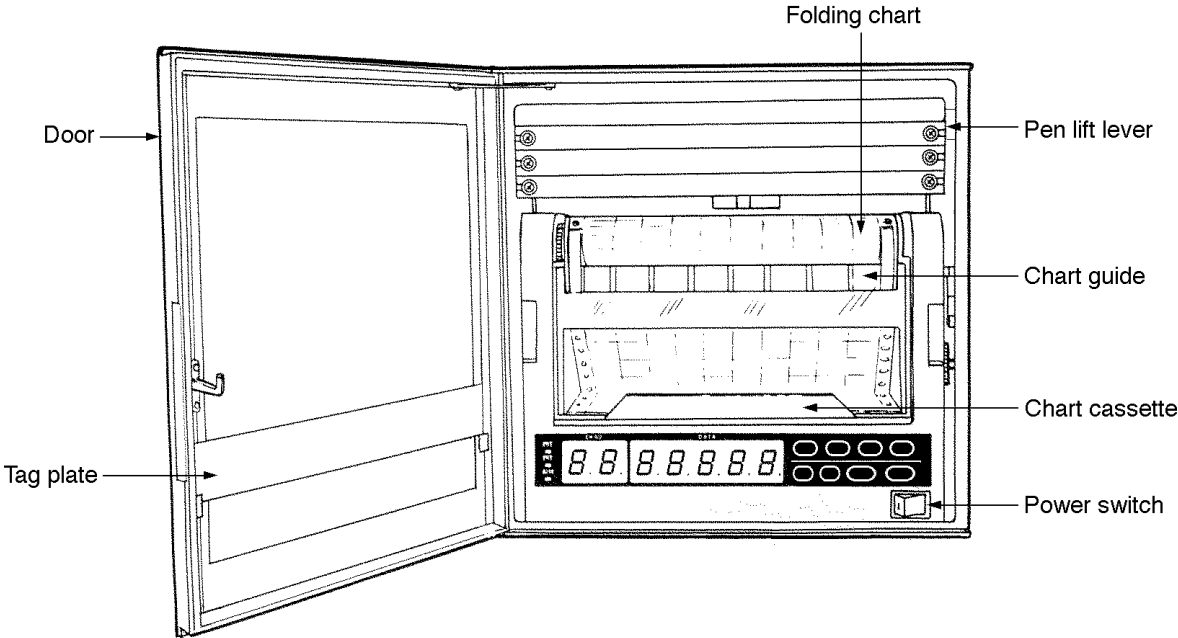

■ Inside

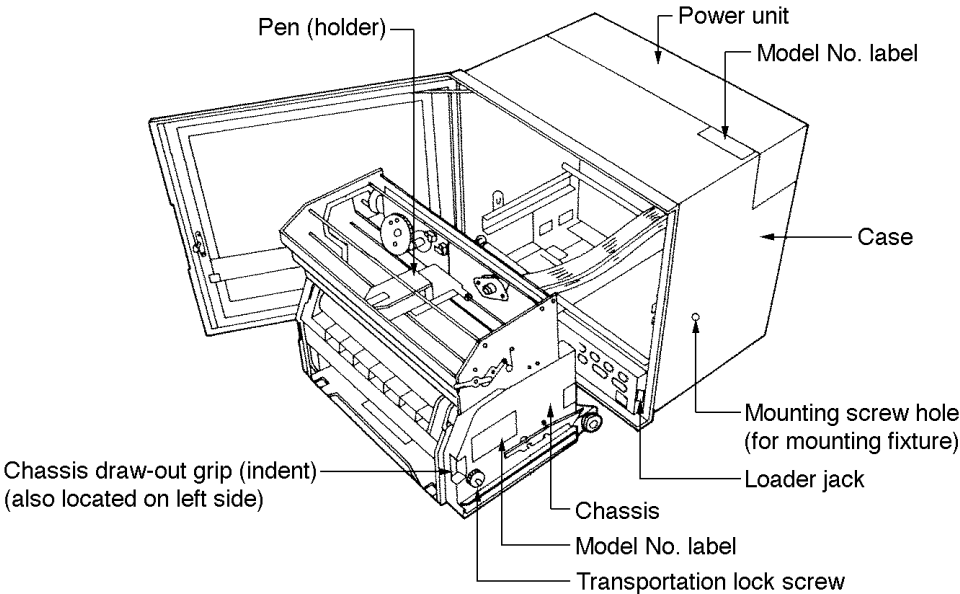

■ Rear Terminal Plate (3-pen model supporting optional functions)

The following figure shows an example of the rear terminal plate for a 3-pen model supporting optional functions.

The shape of input terminals varies according to the semi-multi-input type (see page 1-3).

For details, see “Chapter 3 Installation & Wiring.”

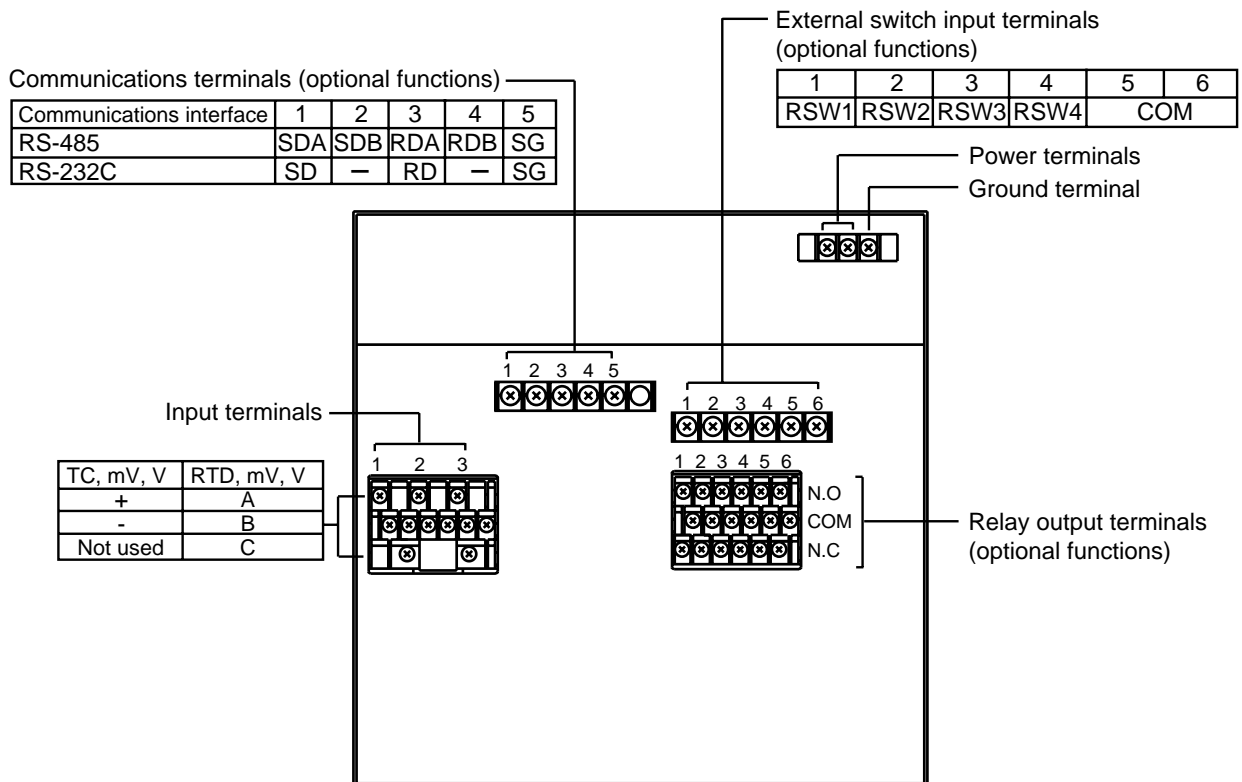

2 - 2 Display Setup Unit

■ Operation Display and Operations Keys

The following describes the operation panel on the display setup unit.

● Operation keys

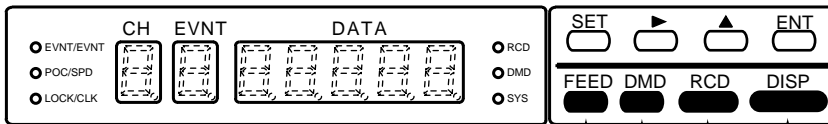

- Display key:
Returns from setup/display selection.
- Record key:
Start/stops recording.
- Demand key:
Starts demand printing.
- Feed key:
Feeds chart for the duration that this key is held down.

● Operation display

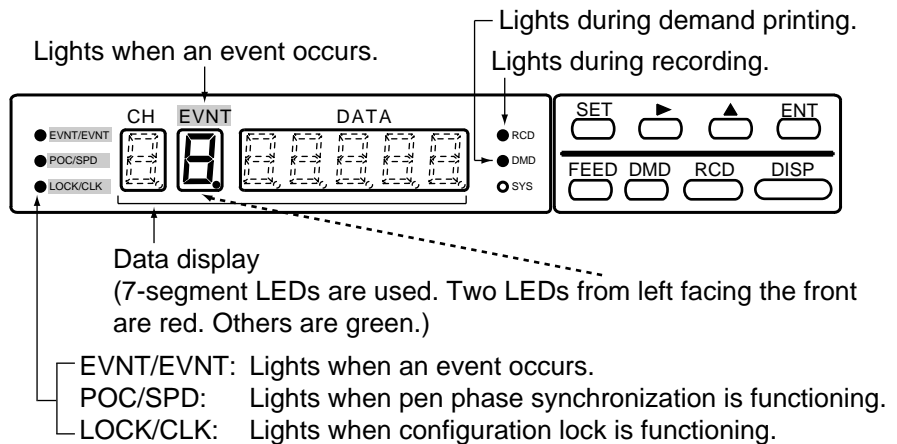

Display examples

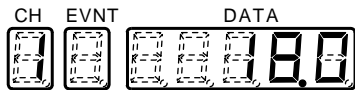

AUTO or MAN indicates the PV input value.
The example on the left shows a value of "18.0" for channel 1.



CLK indicates the date.
The example on the left shows the date "April (04) 27th (27) 1998 (98)". In this example, the "8" in "98" is displayed red.



CLK indicates the time.
The example on the left shows the time "10:10".

■ Configuration Unit and Operation Keys

The following describes the configuration unit on the display setup unit.

● Setup keys

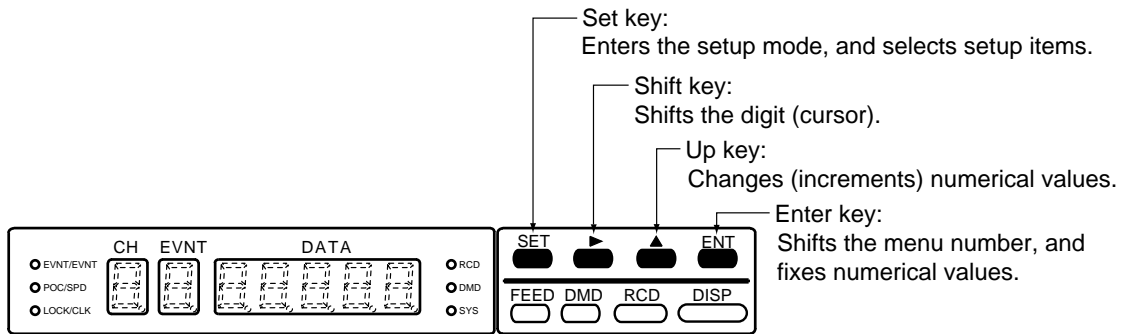

● Setup display

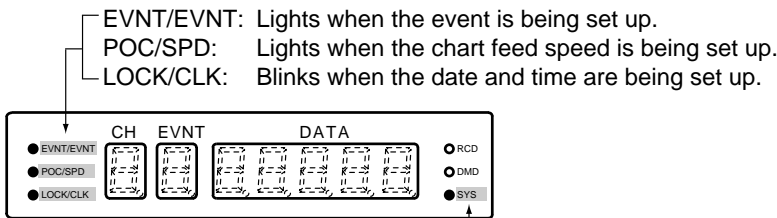

SYS: Lights when system setup 1 (basic setup) is being set up.
 Blinks at 1-second intervals when system setup 2 (range setup) is being set up.
 Blinks at 2-second intervals when system setup 3 (scale setup) is being set up.

Display examples

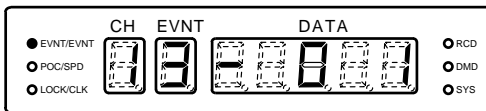

Event setup in progress
 In the example on the left, event setup 3 (event type) on channel 1 is being set up.

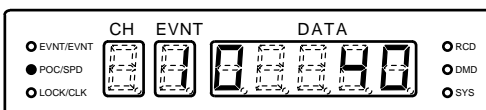
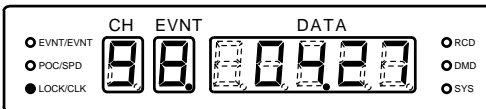
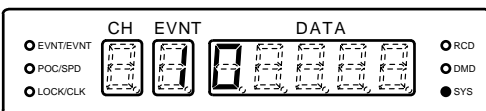

Chart feed speed setup in progress
 In the example on the left, the chart feed speed is "40 mm/h".



Date/time setup in progress
 In the example on the left, the date is "1998, April 27".



System setup 1 (basic) setup in progress
 In the example on the left, the key lock is "OFF (0)".



System setup 2 (range) setup in progress
 In the example on the left, the recording mode on channel 1 is "trend+tabulation".

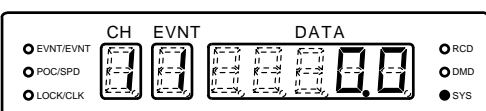

System setup 3 (scale) setup in progress
 In the example on the left, the scale lower limit value on channel 1 is "0.0".

Chapter 3. INSTALLATION & WIRING

3 - 1 Installation Site

The SRF201/202/203 is for indoor installation only. Install the SRF201/202/203 at a location that satisfies the following conditions:

- Locations that are hardly subject to temperature change. Locations close to room temperature
- Locations that are not subject to corrosive gas
- Locations whose humidity is neither too low nor too high
- Locations that are hardly subject to mechanical vibration
- Locations that are hardly subject to dust or oil smoke
- Locations that are hardly subject to the influence of electrical noise
- Locations that are not subject to magnetic fields

! Handling Precautions

- Keep the mounting angle to within 0 to 30° from the bottom rear (bottom rear angle) or to within 0 to 3° from the top rear (top rear angle).
- Use a steel panel of at least 2 to 6 mm in thickness for mounting the SRF201/202/203.

● When mounting from bottom rear

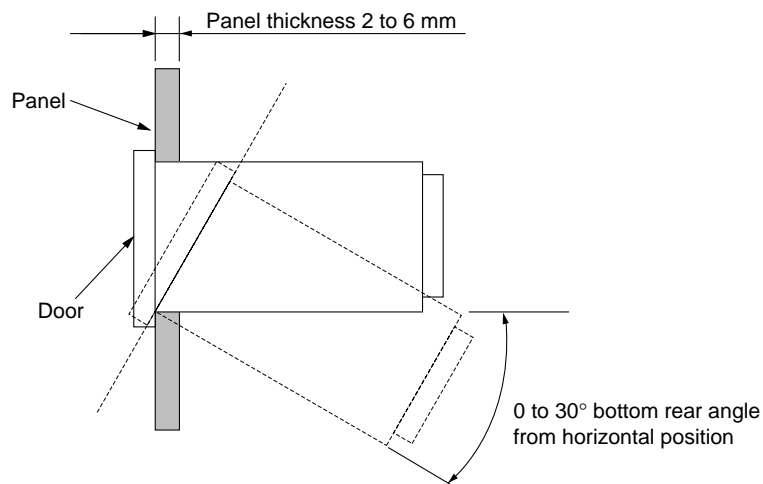

● When mounting from top rear

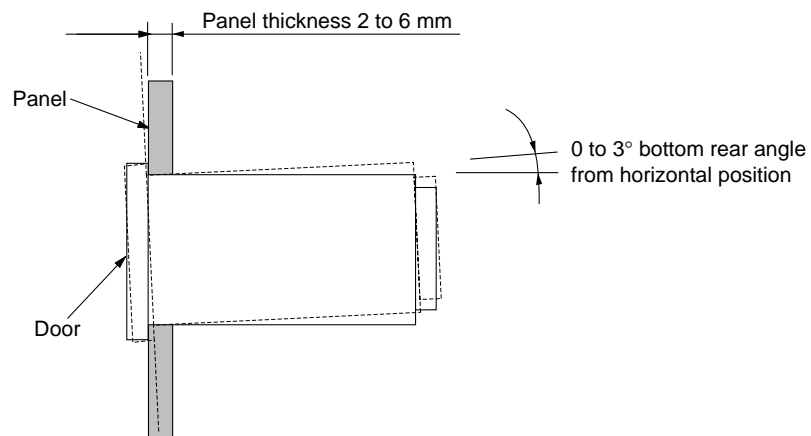

3 - 2 Installation

WARNING



Be sure to turn the power source OFF before mounting the SRF201/202/203. Failure to do so might result in electric shock due to a high power supply voltage.

CAUTION



Tighten the mounting fixture while pushing in firmly to prevent a gap with the panel.
If a gap forms with the panel, the SRF201/202/203 might fall or become loose which is dangerous.

■ Installation Dimensions

The panel cutout dimensions are as follows:

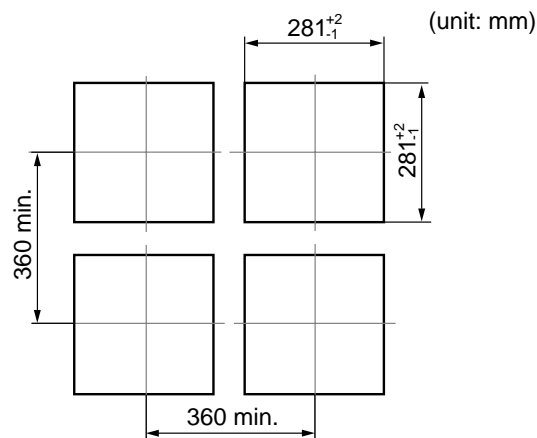

■ Installation Procedure

Mount the SRF201/202/203 by fastening the mounting fixture in the mounting screw holes at the left and right of the case.



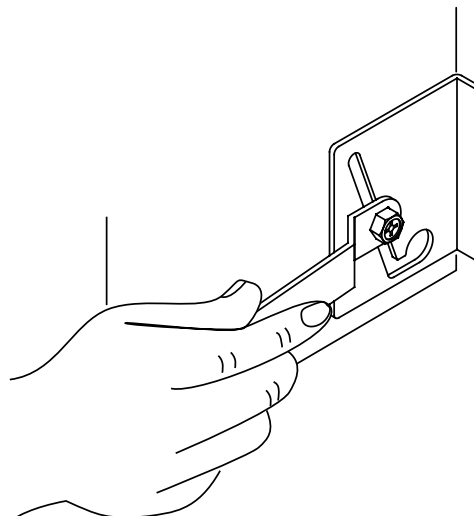

Handling Precautions

The recommended tightening torque for the mounting bracket is 1.0 to 1.5 N•m. Tightening the mounting bracket with a torque higher than this might deform the case or damage the mounting fixture.







3 - 3 Wiring Precautions

WARNING

-  Before wiring the SRF200, be sure to turn the power OFF. Failure to do so might cause electric shock depending on the power voltage.
-  Power is sometimes supplied to the event wiring even if the SRF201/202/203 is turned OFF. Wire with the power source supply to the event wiring turned OFF. Failure to do so might cause electric shock due to a high power supply voltage.
-  After wiring the leads to terminals, do not allow lead clippings to fall into mounting bracket holes or ventilation holes. Failure to do so might cause internal circuits to short-circuit or cause a fire.
-  Before you start wiring, check the model No. of the SRF201/202/203 (including operational functions), and wire to the correct terminals. When you have finished wiring, check the numbers again. Wiring the wrong lead to the wrong terminal might damage the main unit or cause a fire.
-  Be sure to attach the terminal cover after wiring the SRF201/202/203. Failure to do so might cause electric shock. If you have lost the terminal cover, adopt an equivalent measure, or obtain and attach a maintenance part.

CAUTION

-  Do not use unused terminals on the SRF201/202/203 as relay terminals.
-  Use crimped solderless terminals that fit on each terminal screws. For details, refer to “**■ Recommended Crimped Terminal**” on page 3-4.
-  Adopt sufficient noise countermeasures to prevent malfunction caused by electrical noise.
-  Maintain a distance of at least 50 cm between input signal leads and power leads of 100 V or more. Also, do not pass these leads through the same piping or wiring duct.

■ Noise Countermeasures

⚠ CAUTION
<div style="display: flex; align-items: center;"> <div style="margin-right: 10px;">  </div> <div> <p>Maintain a distance of at least 50 cm between input signal leads and power leads of 100 V or more. Also, do not pass these leads through the same piping or wiring duct.</p> </div> </div>

Digital equipment is easily influenced by electrical noise. Conditions that are not a problem on analog equipment might cause digital equipment to become damaged or malfunction. When wiring, pay sufficient attention to the following items to prevent the influence of electrical noise.

● Noise generating sources

Generally, the following generate electrical noise:

- ① Relays and contacts
- ② Solenoid coils, solenoid valves
- ③ Power lines (in particular, 100V ac min.)
- ④ Induction loads
- ⑤ Motor commutators
- ⑥ Inverters
- ⑦ Phase angle control SCR
- ⑧ Wireless communications equipment
- ⑨ Welding equipment
- ⑩ High-voltage ignition equipment

● Noise reducing countermeasures

If the influence of electrical noise cannot be eliminated, we recommend taking the following countermeasures:

- Provision of a CR filter for fast-rising noise
Recommended CR filter: Yamatake Corporation Model No. 81446365-001
- Provision of a varister for noise with a high wave height
Recommended varister:
Yamatake Corporation Model No. 81446366-001 (100 V)
81446367-001 (200 V)

However, note that the varister may become short-circuited when trouble occurs. Pay attention to this when providing a varister on the SRF201/202/203.

■ Recommended Crimped Terminal

Use crimped solderless terminals that conform to the following dimensions for each of the terminals.

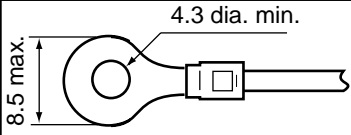
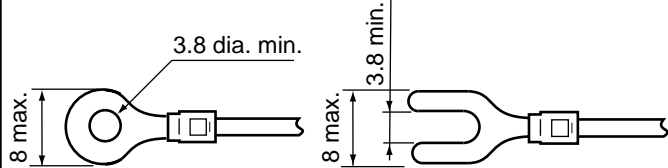
Terminal Name	Screw Dia.	Applicable Crimped Terminal (unit: mm)
Power terminals • Ground terminal	M4	
Input terminal Relay output terminals (optional function) External switch input terminals (optional function) Communications terminal (optional function)	M3.5	

! Handling Precautions

When wiring with crimped solderless terminals, take care to prevent contact with adjacent terminals.

3 - 4 Connecting the Power Supply and Ground

- Use 600 V vinyl-insulated power lead (JIS C 3307) as the power supply lead.
- Obtain the SRF201/202/203 power supply from a single-phase instrumentation power supply not subject to excess noise.
- If the power supply generates excessive noise, add an insulating transformer, and a use a line filter.
Recommended line filter: Yamatake Corporation 81446364-001
- Keep wiring from the line filter as short as possible. Bundling this wiring together is effective against electrical noise.
- After providing anti-noise countermeasures, do not bundle primary and secondary power leads together, or pass them through the same piping or wiring duct.
- Connect the SRF201/202/203 by one-point grounding to the protective ground terminal. Do not perform any jumping wiring. When it is difficult to ground shielded cables, prepare a separate ground terminal (earth bar).
- Grounding type: Lower than 100 Ω
- Grounding conductor: Annealed copper wire 2 mm² (AWG14) or more
- Grounding conductor length: Max. 20 m

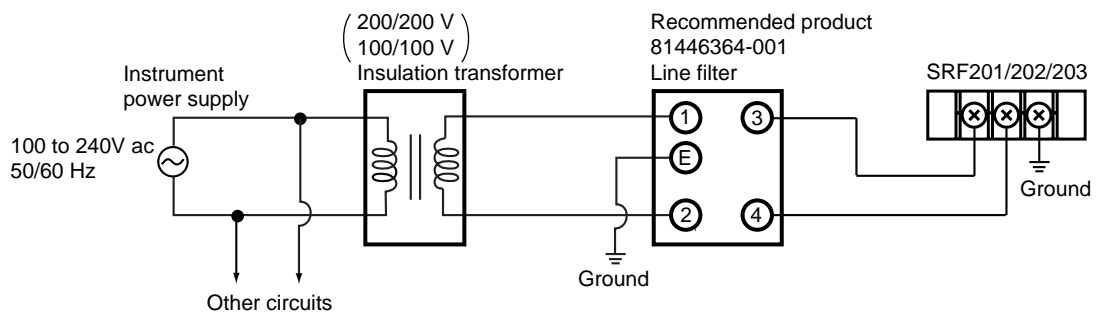

! Handling Precautions

Use a power switch or fuse designed to take rush current into consideration when installing the power switch or fuse outside the SRF201/202/203.

3 - 5 I/O Signal Leads

● Thermocouple input signal lead

In the case of thermocouple input, connect the bare thermocouple lead to the terminal. If the thermocouple is located a long way from the SRF201/202/203, or the thermocouple is connected to a terminal, extend the connection using a compensating lead and then connect to the terminal. Use shielded compensating leads only.

● Resistance temperature detector (RTD)

- Use the three conductors.
- For the conductor, use JKEV-SB (JCS-364) shielded instrument polyethylene insulated vinyl sheath cable or equivalent product. (This is generally referred to as “twisted shielded cable for instruments.”)
- The wiring resistance is 10 Ω or less per conductor.
- Balance the resistances of the three conductors so that they are the same values.

● Analog inputs other than thermocouple and resistance temperature detector (RTD) and digital I/O leads

- Use twisted shielded cable for instruments.
- Shielded, multi-core microphone cord (MVVS) can be used if there is relatively little electromagnetic induction.



Note

- Use no-voltage contact inputs, and assign these contacts for minute currents.
(input no-load voltage: approx. 5 V, input short-circuit current: approx. 6 mA)
- Hold contact signals for 0.5 seconds or more.



Handling Precautions

Be careful not to short-circuit across communications terminals SDA and SDB, or across RDA and RDB. Otherwise, this might damage the communications path.

Input Terminals

The terminal connection changes according to the input type.

For details on input type, see “1-2 Model Selection Guide” (page 1-3).

TC, mV, V inputs

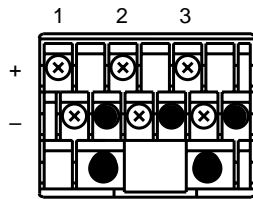

(M3.5 crimped terminal recommended)

Connection	DC voltage	
	Thermocouple	

RTD, mV, V inputs

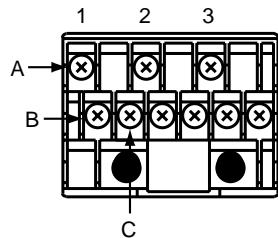

(M3.5 crimped terminal recommended)

Connection	DC voltage	
	Resistance temperature detector	

Wiring Relay Outputs (optional function)

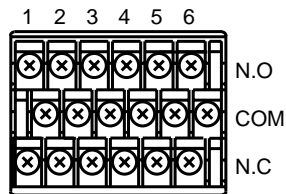

(M3.5 crimped terminal recommended)

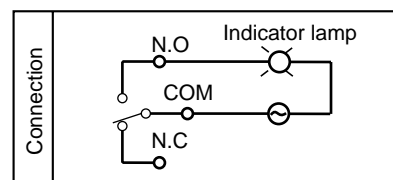

Wiring External Switch Inputs (optional function)

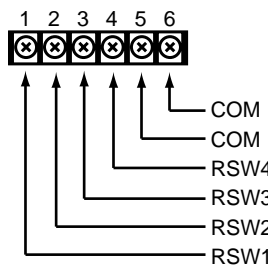

(M3.5 crimped terminal recommended)

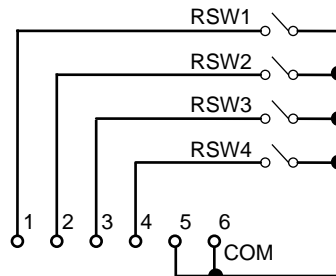

3 - 6 Connecting the RS-485 Interface (optional function)

Read this section when you are using a model that supports the RS-485 communications functions.

The following shows an example with the RS-485 interface connected. In this example, the SRF201/202/203 is the slave instrument.

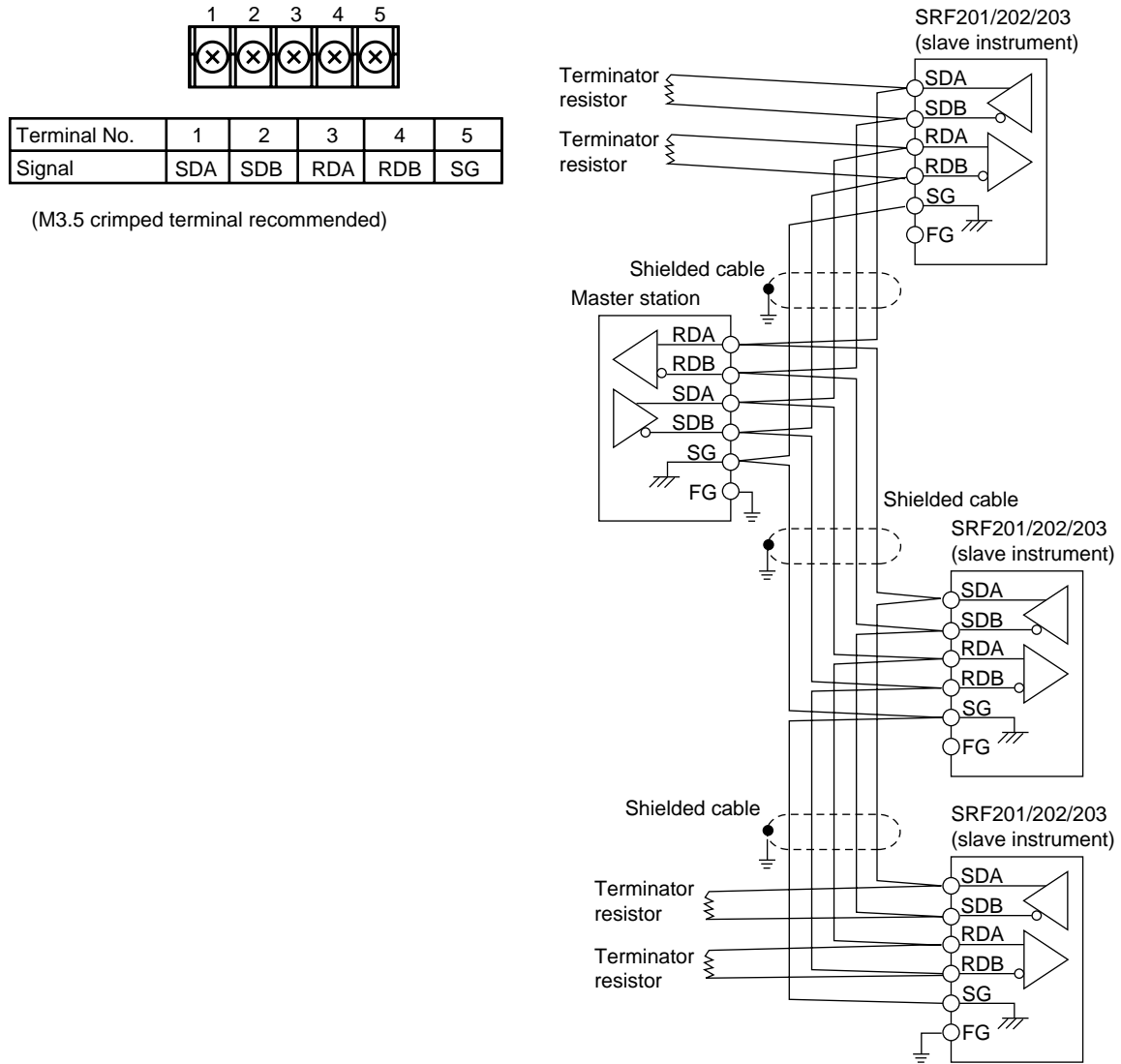

Provide terminators of resistance $150 \Omega \pm 5\%$, 1/2 W min. at both ends of the communications path.

Grounding of the shielded FG terminal should be carried out at only one end and not both ends.

In this 5-lead connection, the Yamatake Corporation CMA50A105 is used as the host instrument converter.

The CMA50A105 can be used as the slave instrument converter when there is only one slave instrument. However, it cannot be used as the slave instrument converter when there are two or more slave instruments.

3 - 7 Connecting the RS-232C Interface (optional function)

Read this section when you are using a model that supports the RS-232C communications functions.

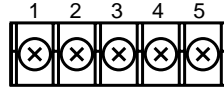

Terminal No.	1	2	3	4	5
Signal	SD	—	RD	—	SG

(M3.5 crimped terminal recommended)

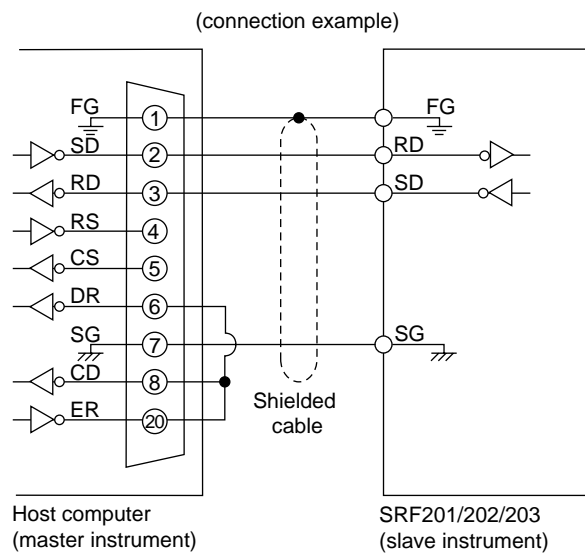

Note

Cable catalog No.: CBL-RS232Z08 (8 m cross-cable for RS-232C)

Chapter 4. PREPARATION & OPERATION

4 - 1 Loading the Chart

Before you start operation, load the folded chart (simply called “chart” from here on) and the pen (trend, printing).

! Handling Precautions

Load the chart either with the power OFF or the SRF201/202/203 in a recording stop state.

To set to a recording stop state during recording, press the **RCD** key. The RCD LED goes out.

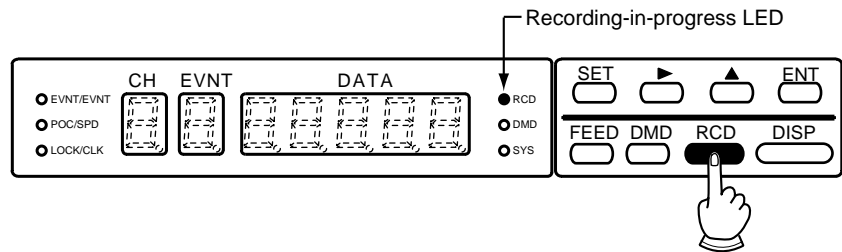

■ Loading (replacing) the Chart

The following describes how to load the chart.

The chart is not loaded in the SRF201/202/203 at shipment. So, this procedure must be carried out when you first use the SRF201/202/203.

- ① Before you load the chart, lightly fan the chart as shown in the figure below:

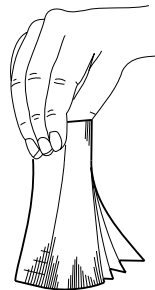

- ② Open the door, and draw out the chart cassette towards you.

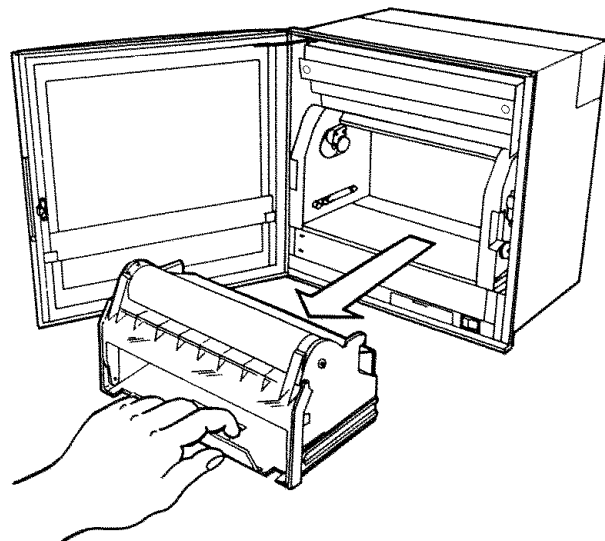

- ③ Open out the chart guide (made of transparent plastic) using its bottom side as a fulcrum, and open out the chart holding spring.

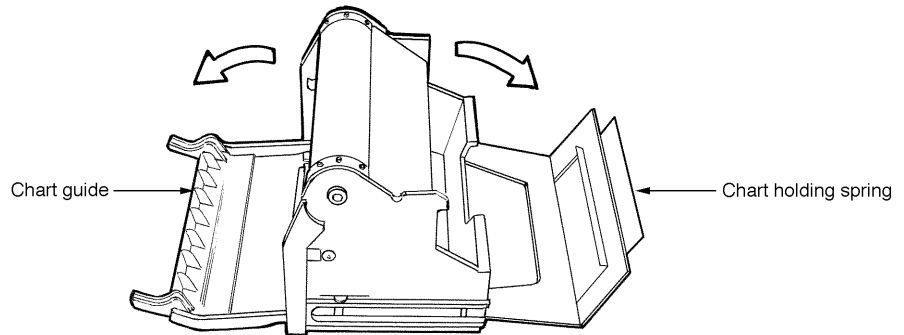

! Handling Precautions

Take care not to deform the spring section at the end of the chart holding spring.

- ④ Fan the chart, insert it into the rear of the chart cassette from the top making sure that it is facing the correct direction, and draw its leading edge out towards the chart guide.

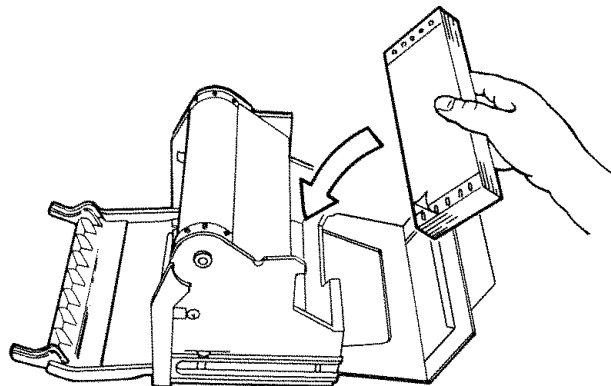

! Handling Precautions

A chart feed error will occur if the chart is not loaded correctly into the chart holder.

- ⑤ Fit three to five folds from the leading edge of the chart on the tray on the chart guide side, and correctly align them on the sprockets.

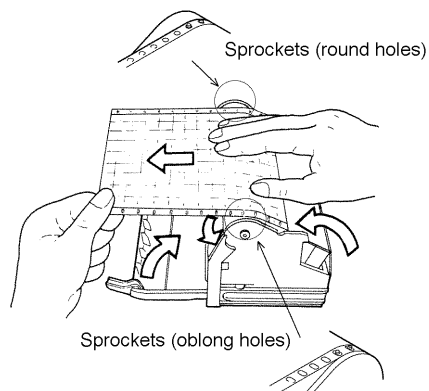

- ⑥ Attach the chart holding spring so that the hooks on the oblong hole side of the chart are under the protrusion on the chart cassette.

! Handling Precautions

Take care not to deform the spring section at the end of the chart holding spring when returning it to its original position.

- ⑦ Push in the chart guide so that the left and right latches are firmly hooked, and close the chart guide.

! Handling Precautions

Make sure that the time line on the chart is parallel with the top edge of the chart guide when viewed from the front.

- ⑧ Gently push the chart cassette into the body as far as possible.

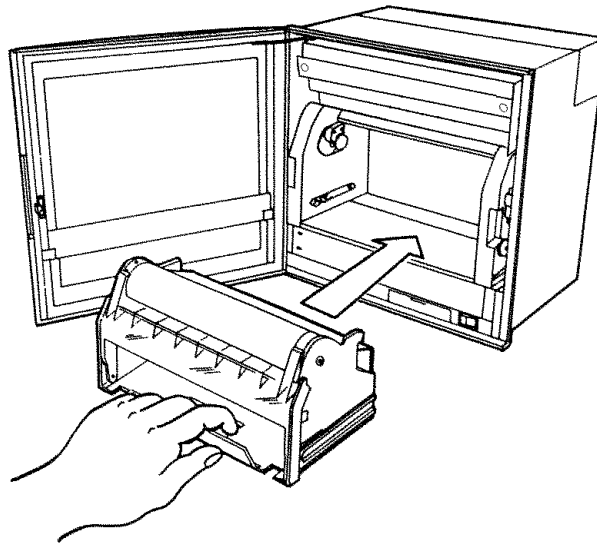

! Handling Precautions

After you have attached the chart cassette, feed the chart by about one fold by pressing the **FEED** key to make sure that the chart is fed properly before you start recording. If the power is not ON, turn the power ON and feed the chart by about one fold.

Note

For details on the chart part No., see “1-2 Model Selection Guide” (page 1-3).

4 - 2 Loading (replacing) the Trend Pen and Printing Pen

Test the pens to see that they write before you load them in the SRF201/202/203.

! Handling Precautions

- Before you carry out the following operations, cancel the configuration lock. For details on how to cancel configuration lock, see “**Canceling Configuration Lock**” (page 5-3).
- After you have removed the pen caps, be sure to store them in a safe place. If operation of the SRF201/202/203 is stopped for more than one day, remove the pens and store them with their caps on.

- ① Set the SRF201/202/203 to the recording stop state.
- ② Press the **DISP** key, and set to one of the AUTO, MAN or CLK modes.
- ③ Press the  key.

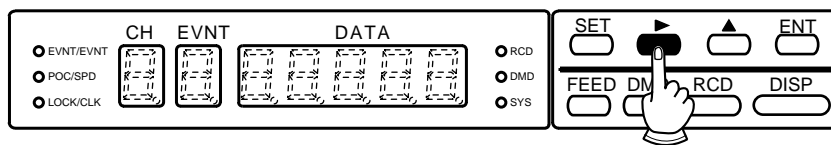

» The pens move as shown in the following figure.

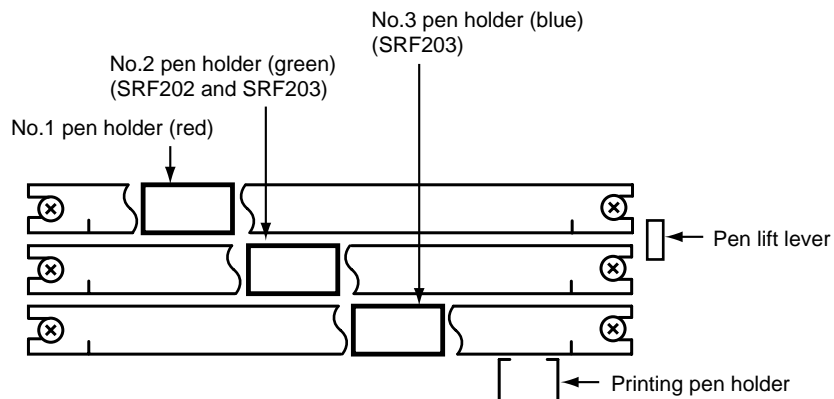

- ④ Raise the pen lift lever and draw out the chart cassette.
- ⑤ Lower the pen lift lever.
- ⑥ Remove the pen caps.
Load the pens in order from the bottom: printing pen, No.3 pen, No.2 pen and No.1 pen.
- ⑦ Rotate the scales of each of the pens upwards so that the pen holder can be seen from the front to load the pens. The scales return if you release your finger. So, carry out this work with the scales held down.



! Handling Precautions

The number of pens varies according to the model No.

 **Note**

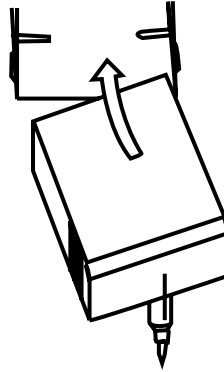
You can load the pens more easily by inserting them slightly at an angle instead of inserting them straight from the front of the holder.



- ⑧ When you have finished loading the pens, raise the pen lift lever, and attach the chart cassette.
- ⑨ Press the  key to return the pens to their original positions before they were replaced.
- ⑩ Lower the pen lift lever.
- ⑪ Press the  key to start recording. Make sure that initial printing and trend printing can be carried out without any problems.

 **Note**

The life of trend pens is about 2500 meters, and the life of the printing pen is about 80,000 characters.

- Spare 1st pens (contains 3 red pens): Model No. 81446632-001
- Spare 2nd pens (contains 3 green pens): Model No. 81446633-001
- Spare 3rd pens (contains 3 blue pens): Model No. 81446634-001
- Spare plotter pens (contains 3 purple pens): Model No. 81446296-001

4 - 3 Operation

Loosen the transportation lock screw if it is tightened. For details on where the transportation lock screw is located, see page 2-1.

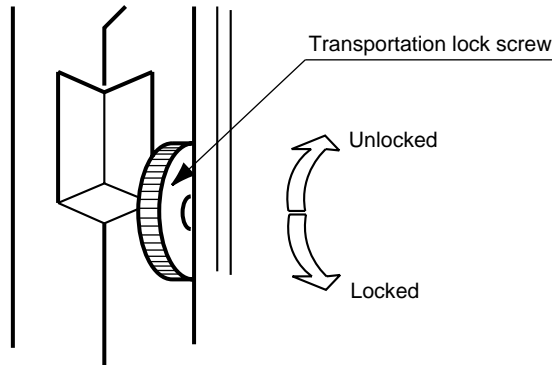

■ Turning the Power ON

Open the door, and press the power switch at the bottom right on the front panel.

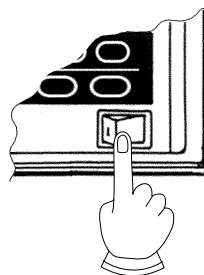

■ Starting/stopping Recording

To start/stop recording, press the **RCD** key.

Press the **RCD** key. The RCD LED lights, and the SRF201/202/203 is set to the recording stop state.

If you press this key again, the LED goes out, and recording stops.

When recording starts, the following items are printed out (this is called “initial printing”).

- Year/Month/Date (last two digits of Western calendar)
- Time (hours/minutes)
- Recording format
- Chart feed speed
- Recorder ID No. (The ID No. is not printed when “00” is set as the ID No.)

! Handling Precautions

Initial printing is not carried out when the power is turned OFF and then ON again in a recording start state. (The operation is the same in the event of an instantaneous power interruption.)

The recording stop/start state is held in memory even if the power is OFF. The same state is returned to when power is next turned ON.

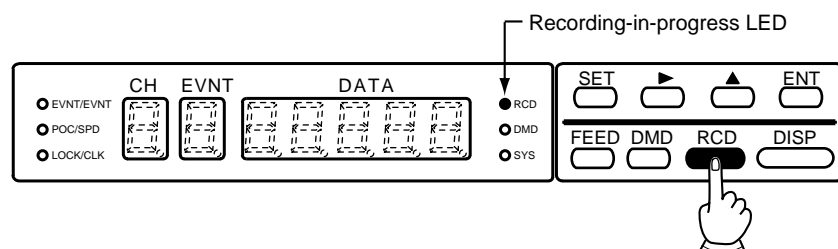

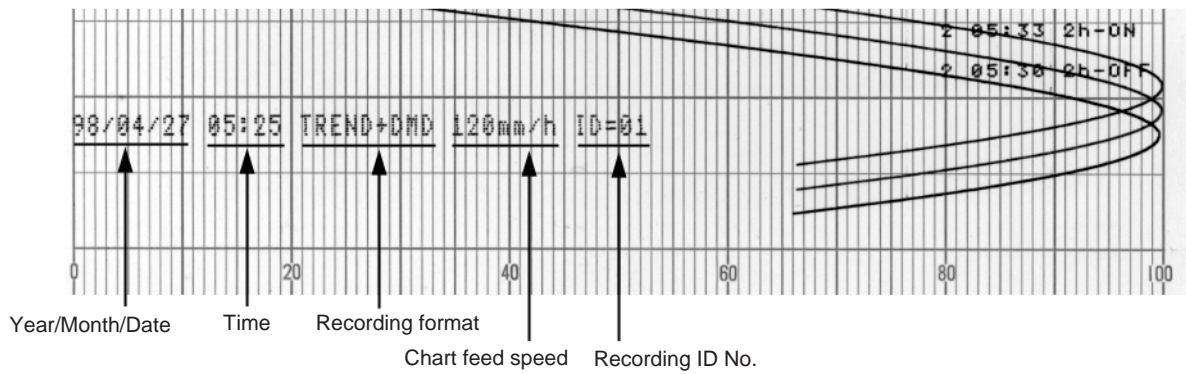

■ Feeding the Chart

To feed the chart forwards when recording is stopped, hold down the **FEED** key. To stop chart feed, release your finger from the key.

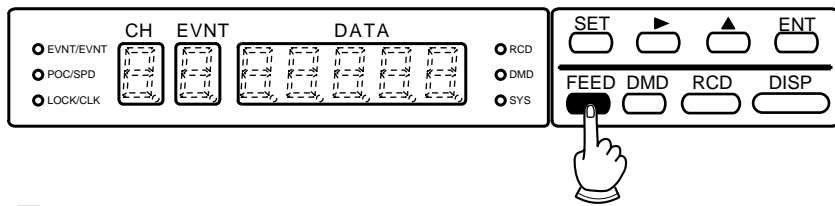

! Handling Precautions

- You cannot operate the **FEED** key during recording.
- To feed the chart backwards, remove the chart cassette, manually fold back the chart to its original position, and attach the chart cassette into the body again.

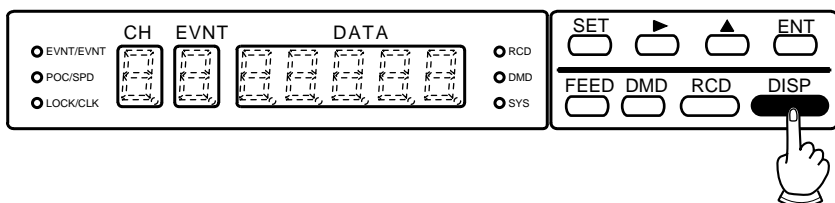

■ Selecting the Display Mode

You can select four display modes by pressing the **DISP** key.

◇ AUTO indicator

This mode successively displays the PV value of each channel automatically “1, 2, 3 1 ... and so forth” at 4-second intervals on the DATA display.

◇ MAN indicator

This mode displays the selected specific channel on the CH display, and the PV value of that channel on the DATA display. To move to the next channel, press the **▶** key.

◇ CLK indicator (year/month/date)

This mode displays the lower two digits of the year on the CH and EVENT displays, and the date using the lower four digits of the DATA display. For example, in the case of April 27th, “04.27” is displayed.

◇ CLK indicator (time)

This mode displays the time (hours:minutes) on the DATA display. The CH and EVENT displays go out.

■ Recording a Specific Table

You can record a table (tabulation) of current PV values by pressing the **DMD** key.

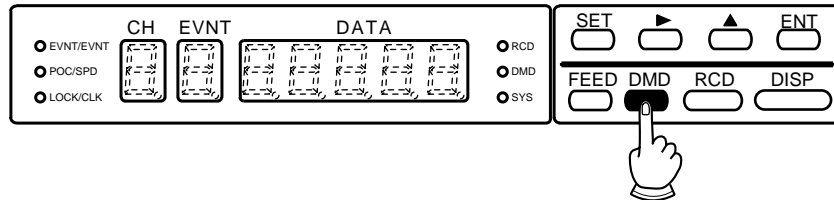

During recording: A table of PV values is recorded overlaying trend data. The tabulation time varies according to the chart feed speed.

During recording stop: Tabulation starts immediately, and ends in about one minute 30 seconds on a 3-pen model.

To cancel tabulation midway, press the **DMD** key again. Pressing this key immediately stops tabulation.

Pressing the **RCD** key during tabulation after tabulation is started during a recording stop is not accepted. Press the **RCD** key after tabulation has ended.

Example 1)

(when the **DMD** key is pressed during recording)

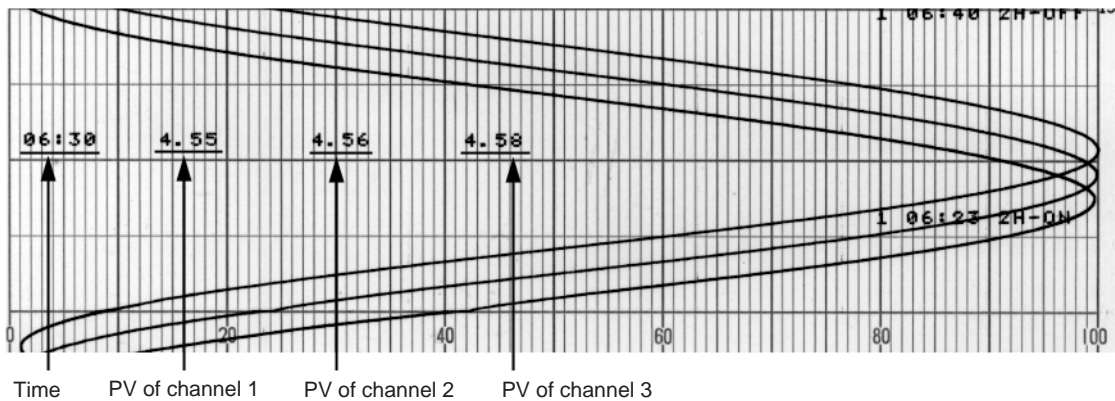

Example 2)

(when the **DMD** key is pressed during a recording stop and the **RCD** key is pressed during tabulation)

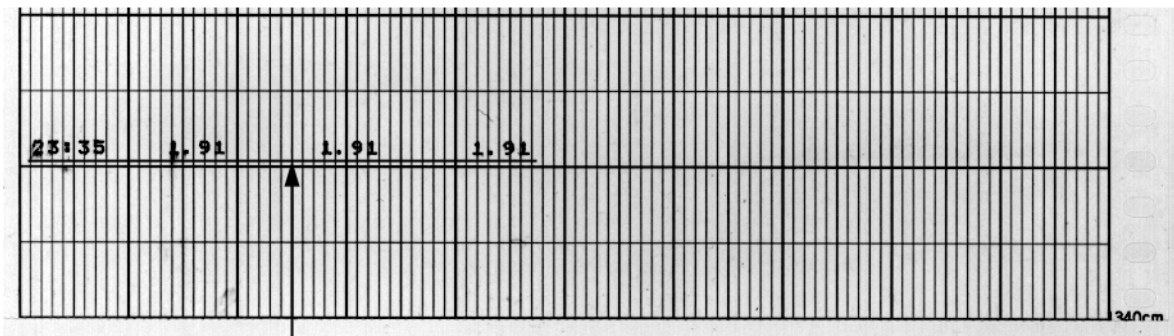

Demand printing

Other Displays and Operations

Display when an event occurs

When an event occurs, the EVNT/EVNT LED lights. When the display mode is set to AUTO or MAN, the status of the event is displayed for the channel where the event occurred.

(Example)

The “H” (HIGH) event occurs on channel 1 (PV value: 520.4)

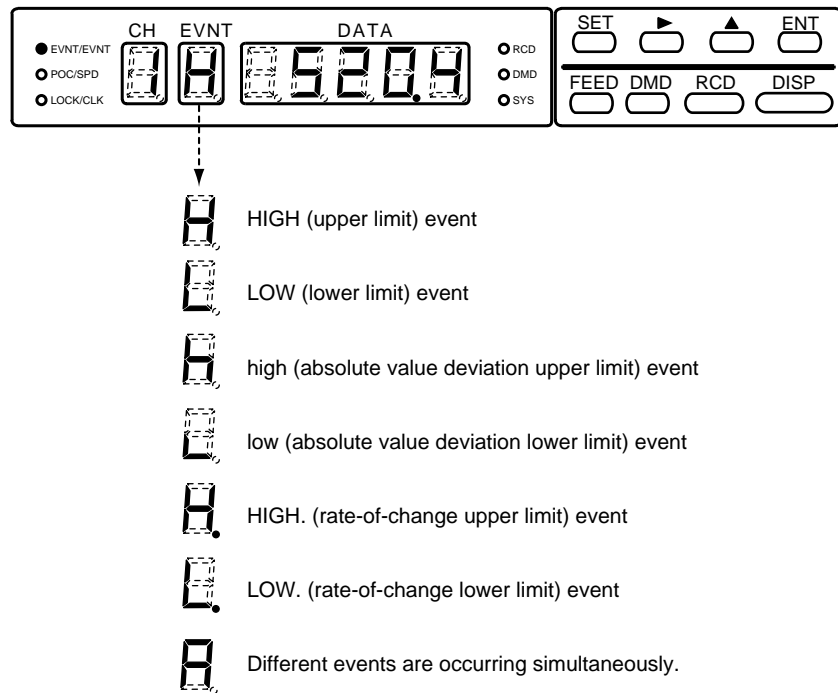

Configuration lock

“Configuration lock” is a feature for preventing the user from changing configuration setups by mistake. When the configuration is locked, setups can be confirmed but not changed.

When the configuration is locked, the LOCK/CLK LED lights. For details on how to cancel configuration lock, see “**Canceling Configuration Lock**” (page 5-3).

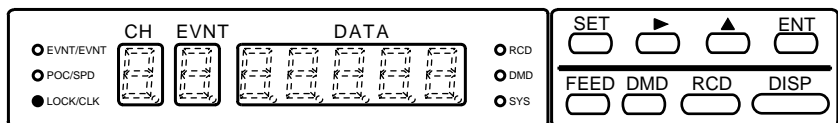

■ **Printout Details**

● **Printout messages (purple)**



Note

For details, see “6-12 Printout Messages” (page 6-21).

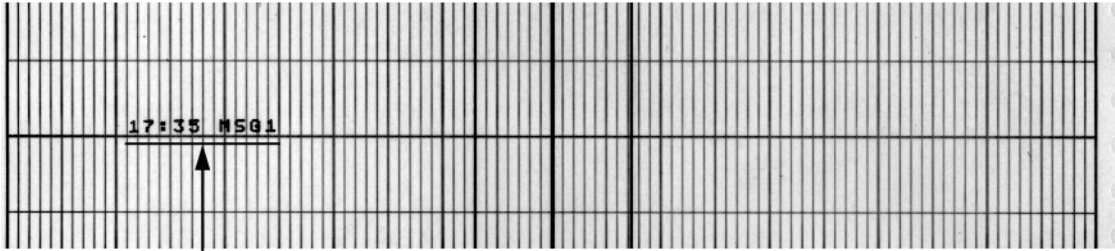

Message printing

● **Example of trend + tabulation recording, and recording when an event occurs**



Note

Digital printing is carried out when the chart feed speed is 150 mm/h or less.

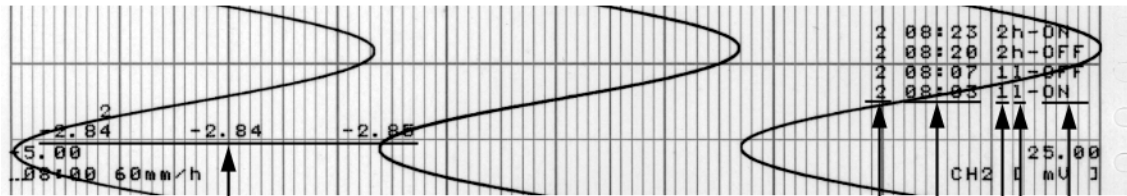

Tabulation recording

CH Time Status
Relay No. Type

Chapter 5. BASIC CONFIGURATION

5 - 1 Introduction

To use the SRF201/202/203, you must first select the input range type, and set the recording scale, chart feed speed and other items. This setup is called “configuration.”

Configuration is sometimes already set up by the device manufacturer in which the SRF201/202/203 is integrated. If the SRF201/202/203 has not been configured or you want to change the configuration setups, refer to “**Chapter 6, Detailed Configuration.**”

On the SRF201/202/203, configuration is divided into two stages:

- For personnel who normally operate the SRF201/202/203.
- For personnel who initially set up the SRF201/202/203.

This chapter describes the setup items listed below whose settings are changed relatively often in normal operation. When the extended menu is set to OFF, four setup items (event setting value, chart feed speed, date/time and list printing) can be set. This chapter describes these setup items.

When the extended menu is set to ON, input range type, recording scale, recording format selection, event type and system setup can be set. Chapter 6, Detailed Configuration describes all of these setup items.

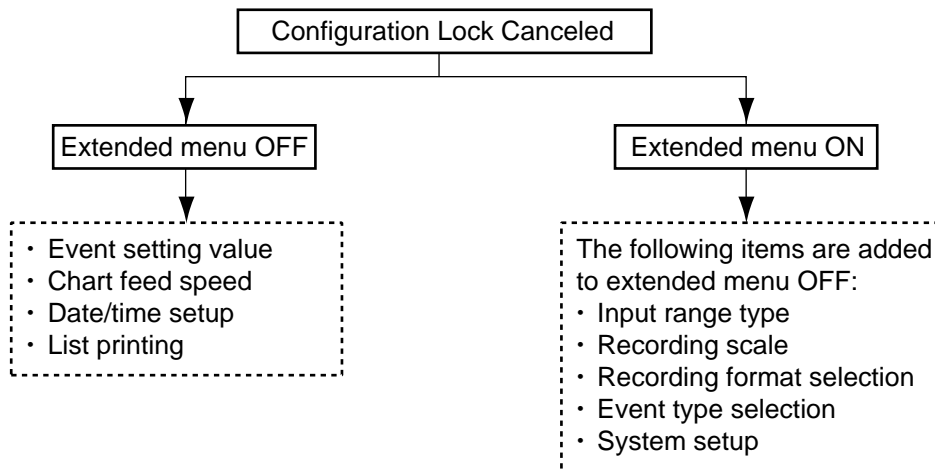

Note

When the configuration is locked, setups can be displayed for confirmation but not changed. (The configuration lock can be canceled at any time.)

Handling Precautions

Data setups can be changed during recording. Note, however, that display recording may end in error depending on details of the change, for example, input type.

5 - 2 Basic Key Operations at Setup, Key Lock and Extended Menu

■ Basic Key Operations at Setup

This section describes common operations at setup.
The figure below shows the display setup unit.

● To start configuration setup

Press the  key.

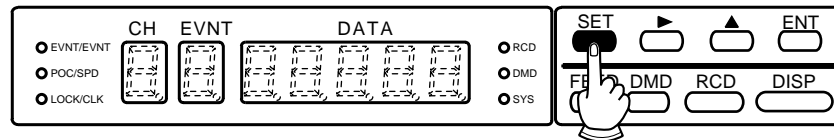



● To change configuration items

Press the  key to advance to the next display number.

● To quit configuration

Pressing the  key in any situation quits configuration.

● To advance to the next display number

Press the  key. The cursor shifts to the display number digit (red LED). Press the  key to shift the display number.

Note



If you have not changed the numerical values of a setup item, pressing the  key shifts the display number without changing the setup.

● To change data

Shift the cursor (blinking digit) using the  key to DATA.

Press the  key to fix the data, and set the data with the  key.

To increment numerical values, press the  key.

When the valid minimum or maximum value of the data is reached, pressing the  key does not change the numerical value. To set the numerical value, press the  key.

Note

To cancel changing of data midway, press either of the following keys without pressing the  key. Any changes made to the currently displayed data at this time are not implemented.

 key : Quits configuration

 key : Advances to the next setup.

You can advance the display number without changing the data by pressing the  keys after shifting the cursor to the display number digit (red LED).

Handling Precautions

If a setting value is in error, all data will blink when you press the  key. If this happens, press any key to return to the entry display. Check the setting values, and reset them if necessary.

■ Canceling Configuration Lock

When the configuration is locked, the LOCK/CLK LED lights and the configuration setup cannot be changed.

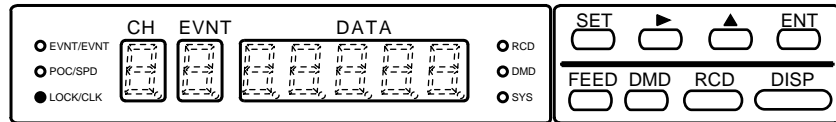

To cancel configuration lock, follow the procedure below:

- ① Press the **SET** key to select SYS.
 - » The SYS LED lights.

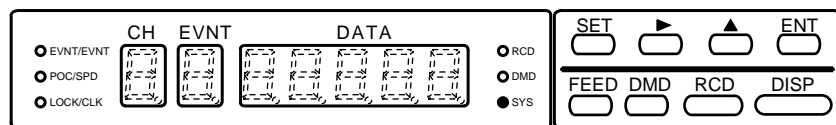

- ② Change the configuration lock setting from “1” to “0” in display number 1.
- ③ Press the **ENT** key.
 - » The LOCK/CLK LED goes out to indicate that the configuration lock is canceled.

■ Switching the Extended Menu ON/OFF

To set initial settings such as range type and recording scale on the SRF201/202/203, turn the extended menu ON.

- ① Press the **ENT** key to select SYS.
- ② Change the extended menu setting from “1 (ON)” to “0 (OFF)” in display number 3.
- ③ Press the **ENT** key.

5 - 3 Changing Event Setting Values

! Handling Precautions

Event setting values are displayed when an event type other than “—” is set. For details on how to set up event types, see page 6-4.

The decimal point position of event setting values is the decimal point position determined by the range code in the case of range codes 200 onwards. In the case of range code 101 to 105 DC voltage inputs, this becomes the engineering range decimal point position (see page 6-12).

- ① Press the **SET** key to select EVNT.
 - » The EVNT/EVNT LED lights.

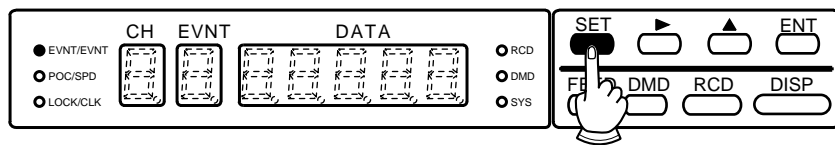

- ② Select the channel No. to be set up using the **▲** key.
 - The following example shows the setup when channel 2 is selected.

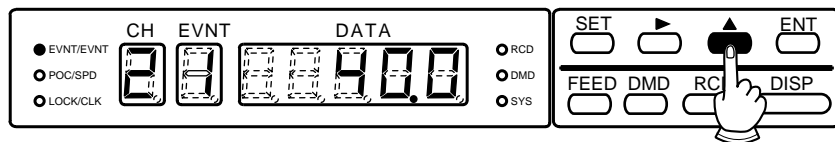

- ③ Up to four events can be set to a single channel. Select which event No. is to be set. Event No.1 will be displayed with the target channel selected.
 - After you have entered the setting value, press the **ENT** key.
 - » Event No.2 is displayed.

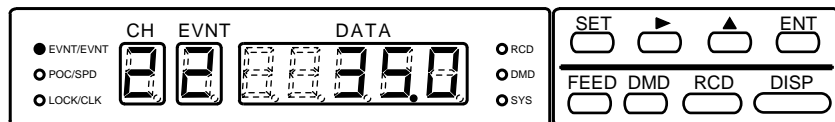

📖 Note

If you press the **ENT** key without setting any value, the next event No. will be selected.

- ④ Change the setting value of the target event.
 - Press the **▶** key.
 - » The cursor moves from the CH display to the uppermost digit of the setup item at DATA.
- ⑤ Enter the setting value of the event using the **▲**/**▼** keys, and press the **ENT** key.
 - » This registers the setting value to memory, and automatically advances the display to the next event No.



5 - 4 Changing the Chart Feed Speed

! Handling Precautions

Chart feed speed 2 is displayed only when the extended menu is turned ON.

- ① Press the **SET** key to select SPD.
 - » The POC/SPD LED lights.

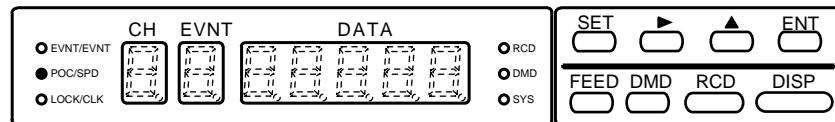

- ② Select the chart feed speed unit using the **▲** key.
 - 0: mm/h (settable in range 1 to 599 mm/h)
 - 1: mm/min (settable in range 10 to 200 mm/min)
- ③ Press the **▶** key.
 - » This returns the display to the chart feed speed setting.
- ④ Set the target chart feed speed using the **▲**/**▶** keys.
 - The numerical value range that can be set varies according to the chart feed speed unit.
- ⑤ Press the **ENT** key.
 - » The cursor stops blinking momentarily, and the setting value is registered to memory.

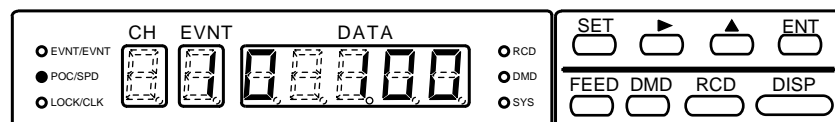

■ Chart Feed Speed and Tabulation Recording Interval

When the recording format (set in system setup 1) is set to “ 2 ” (trend+tabulation), tabulation is carried out on the next hour (XX:00 minutes) when the chart has advanced more than 40 mm.

(Example)

- In case of 20 mm/h: Tabulation is carried out every 2 hours (every 40 mm)
 - When start of recording is set to “12:30”: Tabulation is carried out at “13:00”, “15:00” and so forth
 - When start of recording is set to “13:30”: Tabulation is carried out at “14:00”, “16:00” and so forth
- In case of 40 mm/h: Tabulation is carried out every hour (every 40 mm)
 - When start of recording is set to “12:30”: Tabulation is carried out at “13:00”, “14:00” and so forth
 - When start of recording is set to “13:30”: Tabulation is carried out at “14:00”, “15:00” and so forth

! Handling Precautions

Tables are not recorded when the chart feed speed is 151 mm/h or more.

5 - 5 Changing the Date/Time

! Handling Precautions

If both the date and time are in error, all data will blink when you press the **ENT** key to notify that entry is no longer possible. If this happens, press any key to return to the entry display.

The number of seconds in the time setting are reset (so that counting starts from “00”) when you press the **ENT** key only when the numerical values for the time setting are changed. If you press the **ENT** key without making any changes to the numerical values for the time setting, the date setting display will be redisplayed, and the number of seconds will not be reset.

- ① Press the **SET** key to select CLK.
 - » The LOCK/CLK LED lights.

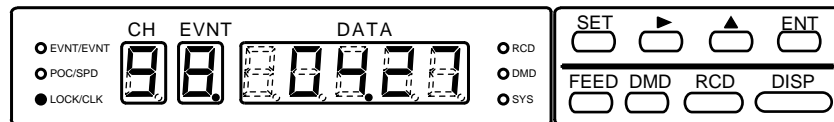

- ② Change the data. The date is arranged in order year (lower two digits of Western calendar), month then day. Shift the cursor to the part of this item that you want to change using the **ENT** key, and change the numerical value using the **ENT** key. Leap years in dates are automatically adjusted. To set the year “2000”, enter “00” as the year.
- ③ Press the **ENT** key.
 - » The display advances to the time setup display.
- ④ Change the time. The time is arranged in order hours (24-hour clock) then minutes. Shift the cursor to the part of this item that you want to change using the **ENT** key, and change the numerical value using the **ENT** key.
- ⑤ Press the **ENT** key.
 - » The data setup display is redisplayed.

Chapter 6. DETAILED CONFIGURATION

6 - 1 Introduction

This chapter describes how to set up configuration items that are initially set on the SRF201/202/203.

Set up configuration items with configuration lock (display number 1 in SYS setup).

If the extended menu is set to ON (display number 2 in SYS setup), you can set up the input range type, recording scale, recording format, event type and system setup.

Handling Precautions

- You can also set up configuration items during recording. However, if the range type or other setup items are changed, display and recording sometimes become temporarily abnormal.
- The Smart Handy Loader is needed to set the following functions. These functions cannot be set on the SRF201/202/203 alone:
 - External switch input function assignment extension (factory setting "ON")
 - Message printing details (factory setting "ON")

Note

For details on event setting values, chart feed speed, date/time setup and list printing to be configured in menu level 1 with the extended menu "OFF", see "Chapter 5, Basic Configuration."

6 - 2 Configuration Data and Factory Settings

■ Event Setup (individual channels): EVNT

Display No.	Setup Item	Setup Description	*Extended menu		Factory Setting
			OFF	ON	
1	No.1 event setting value	-19999 to +29999			0
2	No.2 event setting value	-19999 to +29999			0
3	No.1 event type selection	-, L, H, l, h, L., H.			0 (-): OFF
	No.1 relay output No.	0 to 6			0
	No.1 event recording ON/OFF	0 (OFF)/1 (ON)			1 (ON)
4	No.2 event type selection	-, L, H, l, h, L., H.			0 (-): OFF
	No.2 relay output No.	0 to 6			0
	No.2 event recording ON/OFF	0 (OFF)/1 (ON)			1 (ON)
5	No.1 event differential	0 to 29999			0
6	No.2 event differential	0 to 29999			0

*: The setup level can be changed by switching the extended menu ON/OFF. For details, see page 6-1.

■ Chart Feed Speed Setup: SPD

Display No.	Setup Item	Setup Description	*Extended menu		Factory Setting
			OFF	ON	
1	Chart feed speed unit	0 (mm/h)/1 (mm/min)			0 (mm/h)
2	Chart feed speed	0 to 599 (mm/h)/10 to 200 (mm/min)			40

■ Date/Time Setup: CLK

Setup Item	Setup Description	*Extended menu		Factory Setting
		OFF	ON	
Date				Close to Japan standard time
Time (hours:minutes)				Close to Japan standard time

■ System Setup 1 (individual channels): SYS (OSYS/CLK LED lit)

Display No.	Setup Item	Setup Description	*Extended menu		Factory Setting
			OFF	ON	
1	Configuration lock	0 (OFF)/1 (ON)			0 (OFF)
2	Extended menu entry	0 (OFF)/1 (ON)			1 (ON)
3	Communications access rights selection	1 (read)/2 (read/write)			1 (read)
4	Device address	0 to 127 (setting to "0" inhibits communications)			0
	Communications method	1: 4800 bps, 8 bits even parity, 1 stop bit 2: 4800 bps, 8 bits no parity, 2 stop bits 3: 9600 bps, 8 bits even parity, 1 stop bit 4: 9600 bps, 8 bits no parity, 2 stop bits			1
5	Recording format selection	1 (trend)/2 (trend + tabulation)/3 (trend + schedule demand)			2 (trend + tabulation)
6	Recorder ID No.	0 to 99			0
7	Recording time ON/OFF	0 (OFF)/1 (ON)			1 (ON)
8	Scale recording ON/OFF	0 (OFF)/1 (ON)			1 (ON)
9	Pen phase synchronization setting	1/2/3			3 (pen phase synchronization OFF)
A	Schedule demand selection	0 (OFF)/1 (#1)/2 (#1, 2)/3 (#1, 2, 3)/4 (#1, 2, 3, 4)			0 (OFF)
b	No.1 schedule demand time	0:00 to 23:59			00:00
c	No.2 schedule demand time	0:00 to 23:59			00:00
d	No.3 schedule demand time	0:00 to 23:59			00:00
E	No.4 schedule demand time	0:00 to 23:59			00:00

■ System Setup 2 (individual channels): SYS (OSYS/CLK LED blinks at 1-second intervals)

Display No.	Setup Item	Setup Description	*Extended menu		Factory Setting
			OFF	ON	
1	Recording mode selection	0 (OFF)/1 (display)/2 (display + recording)			2 (display + recording)
2	Range code	Selectable from all codes			105 (± 5 V)
3	Input calculation type	1 (PV)/ 2 (reference channel-own channel)/ 3 (own channel- reference channel)/ 4 (fixed value-own channel)/ 5 (own channel-fixed value)			1 (PV)
4	Reference channel	1 to 3			1
5	Measurement range lower limit	-19999 to +29999			1.000
6	Measurement range upper limit	-19999 to +29999			5.000
7	Engineering range decimal point	0 (xxxxx) to 4 (x.xxxx)			1 (xxxx.x)
8	Engineering range lower limit	-19999 to +29999			0.0
9	Engineering range upper limit	-19999 to +29999			100.0
A	Fixed value for deviation	-19999 to +29999			0
b	PV bias	-19999 to +29999			0
C	Engineering unit setting (UNIT)	6 characters			Blank

■ System Setup 3 (individual channels): SYS (OSYS/CLK LED blinks at 2-second intervals)

Display No.	Setup Item	Setup Description	*Extended menu		Factory Setting
			OFF	ON	
1	Scale lower limit	-19999 to +29999			0.0
2	Scale upper limit	-19999 to +29999			100.0

6 - 3 Event Setup

■ Event Setup

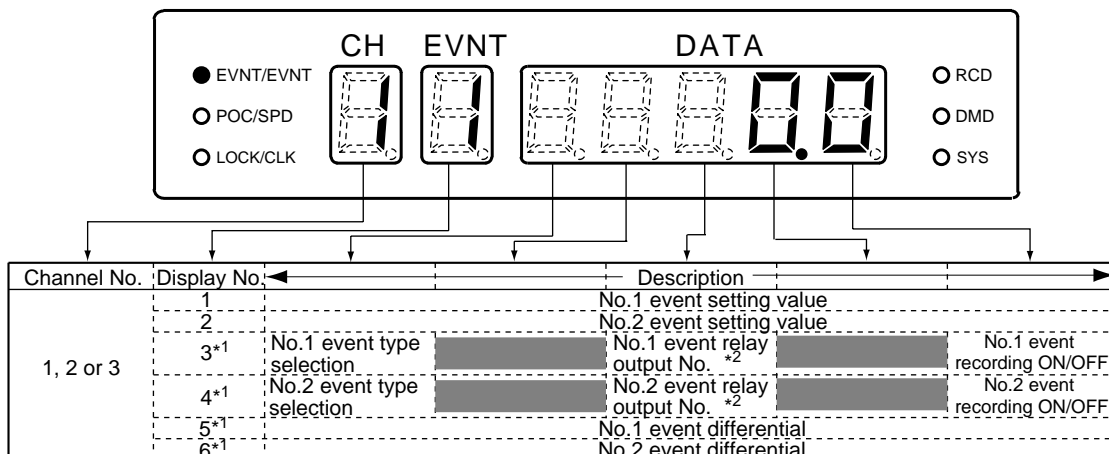

*1: This is displayed when the extended menu is ON.

Event setting values are not displayed when the event type is set to “-” (event OFF).

*2: Event setting values that do not support the relay output optional function are not displayed.

● Setup Details

- Event setting value : “-19999 to +29999” (U)
- Event type : “-” no event
 “H” (upper limit)
 “L”(lower limit)
 “l” (absolute value deviation lower limit)
 “h” (absolute value deviation upper limit)
 “L.” (rate-of-change lower limit)
 “H.” (rate-of-change upper limit)

- Definition of “absolute value deviation”
 Absolute value deviation =
 $| \text{own channel PV (actual PV before input calculation)} - \text{fixed value (event setting)} |$
 where,
 Event setting value : Used for setting the fixed value
 Differential : Used as the setting value of the absolute value deviation
 Differential gap : Fixed at 10 U

- Definition of “rate-of-change”
 Rate-of-change =
 Change Δ PV in a cycle (set by differential, unit: seconds) having PV input is judged as being either larger or smaller than the event setting value. Changes in PV midway are ignored.
 where,
 Differential setting value : Used for setting the judgment cycle
 Differential gap : Fixed at 10 U*
 Relay output No. : “0 to 6” (“0” relay output OFF, “1 to 6” can be set only when relay output is supported as an optional function)
 Event recording ON/OFF : “0” event recording OFF
 “1” event recording ON
 Event differential : “0 to 29999” (U)

📖 Note

*10 U = 10 times the minimum setting resolution. The “minimum setting resolution” is the resolution according to the engineering range number of digits past the decimal point. For example, when the number of digits past the decimal point is set to “XXX.XX” the minimum setting resolution will be “0.01”.

■ Description of Event Setup Items

● Event type and operation

Event type "H" (PV upper limit)

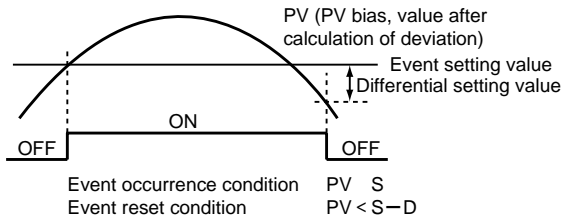

Event type "L" (PV lower limit)

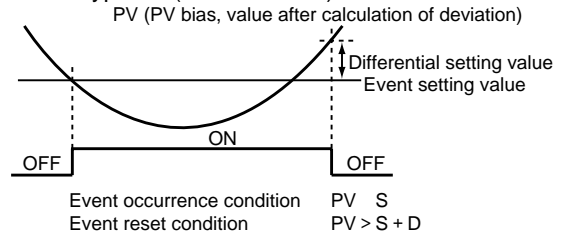

Event type "h" (absolute value deviation upper limit)

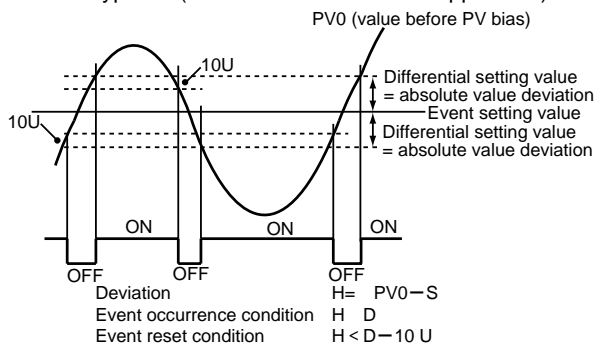

Event type "l" (absolute value deviation lower limit)

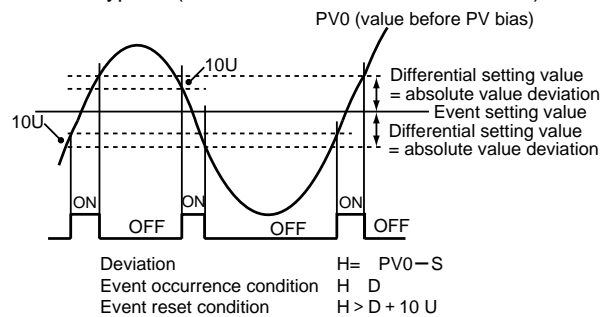

Event type "H." (rate-of-change upper limit)

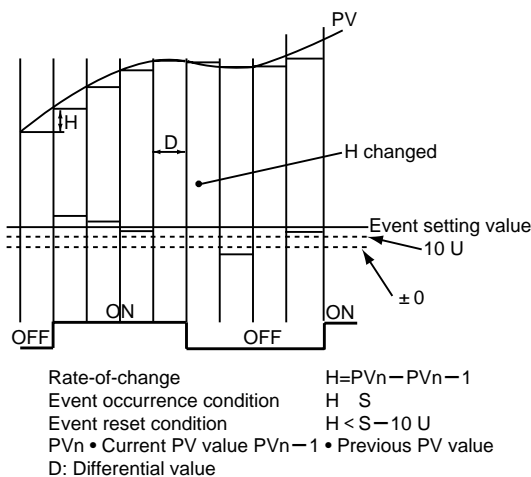

Event type "L." (rate-of-change lower limit)

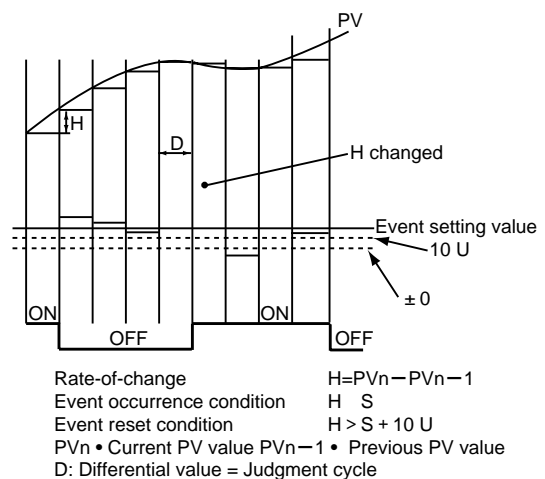

! Handling Precautions

The rate-of-change event compares the amount of change with the setting value at each judgment cycle that is preset as shown above. Accordingly, the event sometimes does not turn ON according to the timing of the judgment cycle even if a PV rate-of-change likely to the turn the event ON occurs.

● **Event relay No.**

Output to all relays is disabled when the event relay No. is set to “0”. Two events can be set to a single channel. The same event relay No. can be set to different channels. In this case, the relay that is used in duplicate is OR-ed and cannot be AND-ed.

! **Handling Precautions**

Event relay Nos. other than “0” can be set only when relay output (optional function) is supported.

● **Event recording ON/OFF**

When event recording is set to OFF, neither event occurrences nor resets are recorded.

● **Event buffer**

Up to 48 events including occurrence and resets can be buffered.

● **Relay excitation direction and contact**

The coil of the specified relay is excited when an event occurs. The contact is transfer contact output (both NO and NC contacts are output by SPDT output).

● **Relay contact rating**

- 100V ac, 0.2 A (non-inductive load), 30V dc, 0.3 A (non-inductive load)
- Minimum load: 10mV dc, 10 μ A
- Electrical life: 100,000 operation (resistive load)

6 - 4 Chart Feed Speed Setup

■ Chart Feed Speed Setup

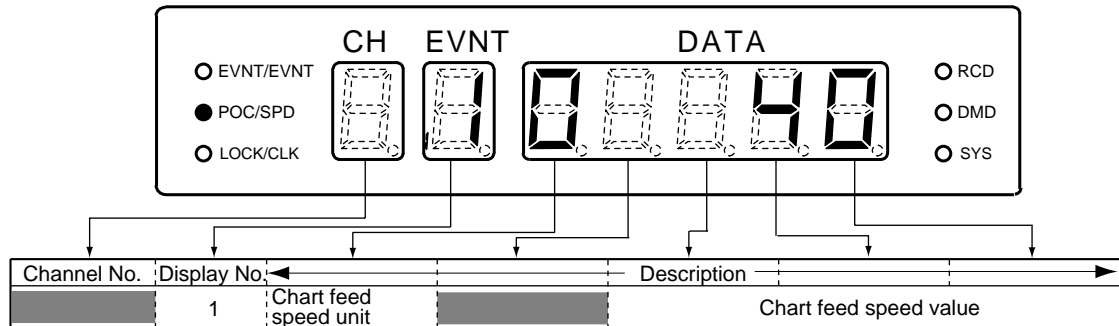

! Handling Precautions

- When pen phase synchronization is carried out on a 2- or 3-pen model, the pen synchronization memory is cleared when the chart feed speed is changed. When this happens, the No.1 and No.2 pens stand by at the left edge at the start time position of the No.3 pen. For details of pen synchronization, see “● About pen synchronization” (page 6-10).
- Characters are not printed when the chart feed speed is 151 mm/h or more.

● Setup Details

Chart feed speed unit	: “0” (mm/h) “1” (mm/min)
Chart feed speed value	: “1 to 599” (when unit is set to mm/h) “10 to 200” (mm/min)

■ Description of Chart Feed Speed Setup Items

● Chart feed speed and printing cycle

The time reference for the tabulation printing cycle is “00:00”. The tabulation interval on the chart paper is 40 mm. If, for example, the chart feed speed is 20 mm/h, then the tabulation time becomes 00:00, 02:00 and so forth up to 22:00. To carry out tabulation printing at a specific time, select “trend + schedule demand” printing as the recording format.

● Chart feed speed and date printing

Chart feed speed and date are printed alternately.

📖 Note

Chart Feed Speed and Character Size

Characters are expressed as a 5 x 7 dot matrix, and are 1.2 mm wide. Their vertical length varies according to the chart feed speed.

! Handling Precautions

Characters are not printed when the chart feed speed is 151 mm/h or more.

6 - 5 Date/Time Setup

■ Date/Time Setup

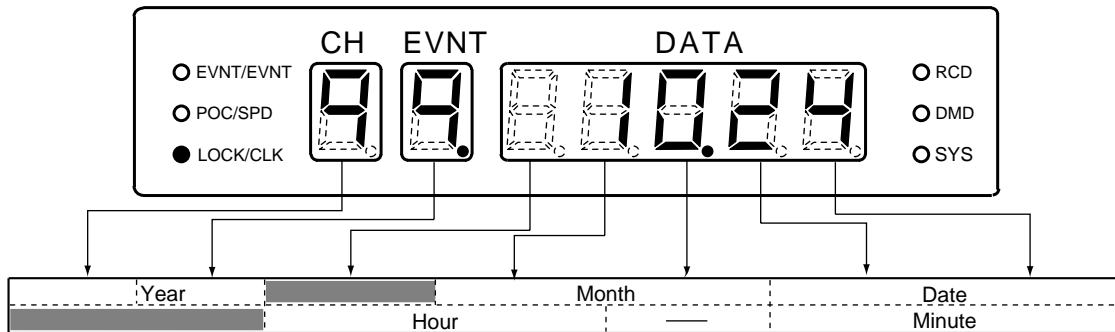

! Handling Precautions

If the date and time setup is in error, all data blinks when you press the **ENT** key. If this happens, press any key to redisplay the data entry display.

The number of seconds in the time setup are reset (so that counting starts from "00") when you press the **ENT** key only when the numerical values for the time setup are changed. If you press the **ENT** key without making any changes to the numerical values for the time setup, the date setup display will be redisplayed, and the number of seconds will not be reset.

● Setup Details

Year : "94 to 99" 1994 to 1999
 "00 to 93" 2000 to 2093
 Month : "01 to 12" January to December
 Day : "01 to 31" 1st to 31st
 Hour : "00 to 23" 0 am to 11 pm
 Minute : "00 to 59" 0 to 59 minutes

📖 Note

- Clock accuracy is about ± 50 ppm or about 120 seconds/month under standard conditions.
- The SRF201/202/203 automatically adjusts for leap years.

6 - 6 System Setup 1 (Basic Setup)

■ System Setup 1 (SYS LED is lit continuously)

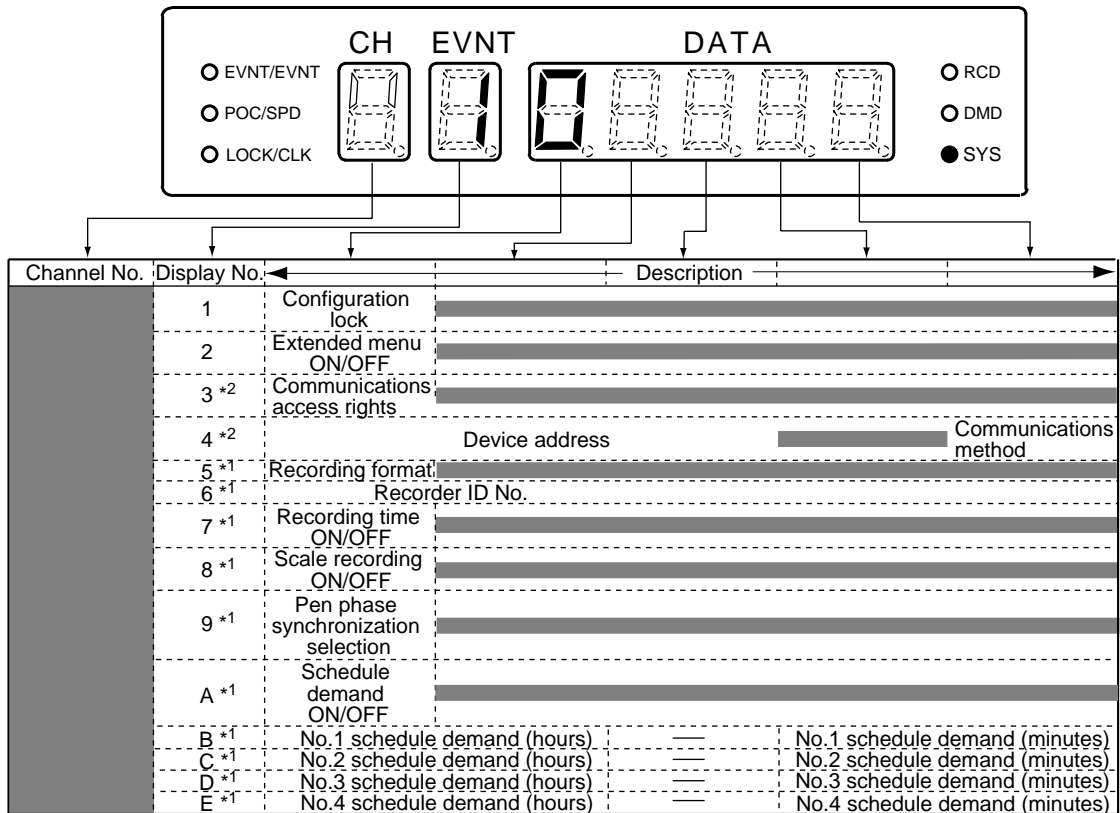

*1: This is displayed when the extended menu is ON.

*2: These are not displayed on models that do not support communications (optional function).

! Handling Precautions

When the configuration is locked, setups can be confirmed but not changed.

● Setup Details

- Configuration lock : "0" (OFF: disabled)
"1" (ON: enabled)
- Extended menu ON/OFF : "0" (OFF)
"1" (ON: enabled)
- Communications access rights : "1" (read only)
"2" (read/write)
- Device address : "0 to 127" (communications is inhibited when set to "0".)
- Communications method : "1" (4800 bps, 8 bits, even parity, 1 stop bit)
"2" (4800 bps, 8 bits, no parity, 2 stop bits)
"3" (9600 bps, 8 bits, even parity, 1 stop bit)
"4" (9600 bps, 8 bits, no parity, 2 stop bits)
- Recording format : "1" (trend)
"2" (trend + tabulation)
"3" (trend + schedule demand)
- Recorder ID No. : "0 to 99" (ID No. is not printed when set to "0")
- Time recording ON/OFF : "0" (OFF: time is not recorded)
"1" (ON: time is recorded)
- Scale recording ON/OFF : "0" (OFF: scale is not recorded)
"1" (ON: scale is recorded)
- Pen phase synchronization selection : "1" (All pens are compensated referenced to the printing pen.)
"2" (All pens are compensated referenced to the reference pen.)
"3" (Pen phase is not compensated.)

Schedule demand ON/OFF	: “0” (Printing is not carried out at any preset time.) “1” (Tabulation printing is carried out at the No.1 time.) “2” (Tabulation printing is carried out at the No.1 and No.2 times.) “3” (Tabulation printing is carried out at the No.1, No.2 and No.3 times.) “4” (Tabulation printing is carried out at all No.1, No.2, No.3 and No.4 times.)
Schedule demand hours:minutes setting	: “0 to 23” (hours) “0 to 59” (minutes)

■ Description of System Setup 1 Items

● How to use the recorder ID No.

When you are using two or more SRF201/202/203s, you can print individual recorder ID Nos. when printing is started to distinguish which recorder is being used to record on the chart.

The recorder ID No. is not used for applications other than printing.

● About time recording OFF

When time recording is set to OFF, no date/time information is printed on the chart. To give priority to real-time recording, leave the time recording setup to “ON” (factory setting).

● About pen phase compensation (POC)

The difference (phase) between the positions of the printing pen and the trend recording pens can be matched (synchronized) using the memory function so that recording is carried out without any phase difference between the pens on the time axis on the chart.

Display is carried out in real time at all times regardless of the pen phase synchronization setting.

“1” The phases of all printing pen and trend recording pens are synchronized.

The printing pen is referenced to time. The trend recording pens operate delayed by the difference in mechanical positions with the printing pen.

Accordingly, all trend recording pens operate with a delay after actual PV movement.

The time line is printed as “ _ _ ”.

“2” The phases of all printing pen and trend recording pens are synchronized, however the reference pen of the trend recording pens will be referenced to time. (On 1-pen models, this is the No.1 pen; on 2-pen models, this is the No.2 pen; and on 3-pen models, this is the No.3 pen.)

Accordingly, only the standard pen operates together with actual PV movement.

The printing pen operates first to print the time. The time line is printed as “ _■_ ”.

“3” The phase of the trend recording pens is not compensated.

Accordingly, the recording results will no longer be synchronous. However, all trend recording pens operate together with actual PV movement, and the time line is not printed.

! Handling Precautions

If the chart feed speed is changed while the pen phase is being synchronized, all data stored in memory so far will be cleared, and trend pens other than the reference pen will move to the left edge.

● **Distance between pens (pen tips)**

Between printing pen and No.3 pen: About 4.5 mm

Between No.3 pen and No.2 pen, and No.2 pen and No.1 pen: About 4.0 mm

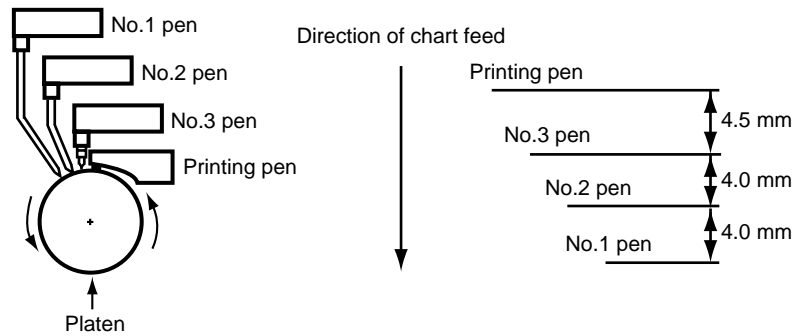

● **Schedule demand**

When “trend + schedule demand” recording is selected as the recording format, and steps B to E in the setup procedure are set, tabulation can be recorded at the necessary times up to four times per day.

If schedule demand is set, and the SRF201/202/203 is set to a recording state, recording will be carried out without any omissions, for example, when recording processes that require recording at fixed times, or when recording process values at the change of operator shifts.

6 - 7 System Setup 2 (Range Setup)

■ System Setup 2 (SYS LED blinks at 1-second intervals)

This is displayed when the extended menu is ON.

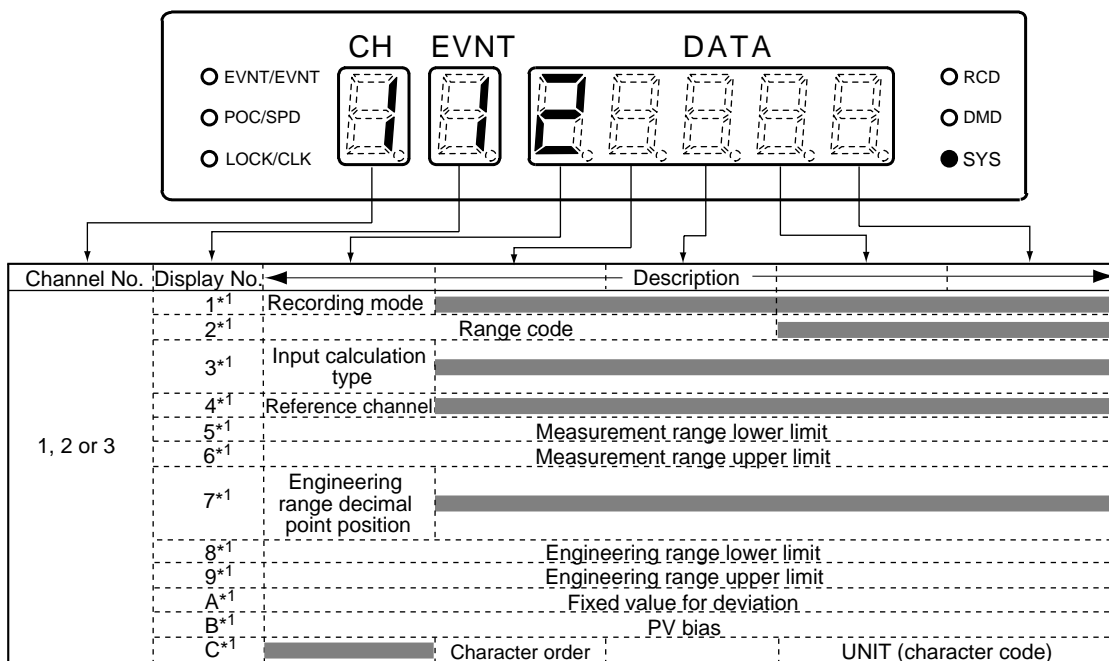

*1: When the range code has been changed, the display will be initialized to match the range code.

! Handling Precautions

Some items are not displayed depending on the setup details such as range code or input calculation type.

● Setup Details

Recording mode	: "0" (display/recording OFF) "1" (display only) "2" (display + recording)
Range code	: See " 6-9 Range Code Table " (page 6-17) (example: 230 → thermocouple/-200.0 to +1370.0°C)
Input calculation type	: "1" (PV value) "2" (reference channel - own channel) "3" (own channel - reference channel) "4" (fixed value - own channel) "5" (own channel - fixed value)
Reference channel	: "1 to 3" (Select reference channel to be used for calculating the channel)
Measurement range upper/lower limits	: "-19999 to +29999" (U) (For details on the decimal point position of the measurement range, see " 6-9 Range Code Table " (page 6-17).)
Engineering range decimal point	: "0 to 4" (0 → XXXXX, 1 → XXXX.X, 2 → XXX.XX ...)
Engineering range upper/lower limits	: "-19999 to +29999" (U)
Fixed value for deviation	: "-19999 to +29999" (U)
PV bias	: "-19999 to +29999" (U)
Character order	: "1 to 6" (change by ENT key)
UNIT (Engineering unit)	: See " 6-10 Character Code Table " (page 6-19)

■ Description of System Setup 2 (Range Setup)Items

● Recording mode and operation

Recording Mode	Input Processing	Event	Recording
"0" display/recording OFF	X	X	X
"1" display only	Operable	Operable	X
"2" display + recording ON	Operable	Operable	Operable

Recording modes 1 and 2 are operable even when recording is OFF.

● Range code selection

The SRF201/202/203 supports full multi-input. Merely selecting the range type here fixes the range code.

● Details of input calculation type

"2": {(reference channel raw PV value) + (reference channel bias value)} - {(own channel raw PV value) + (own channel bias value)}

"3": {(own channel raw PV value) + (own channel bias value)} - {(reference channel raw PV value) + (reference channel bias value)}

"4": (fixed value) - {(own channel raw PV value) + (own channel bias value)}

"5": {(own channel raw PV value) + (own channel bias value)} - (fixed value)

● Input calculation type and calculation result

The calculation result is displayed as the data of the own channel, and recording and event processing is carried out.

● Position of engineering range decimal point and engineering range upper/lower limit values

These settings determine the display resolution of the measurement range. The resolution of trend recording is fixed to 1/3600 regardless of these settings.

● About reverse scaling

Reverse scaling can be set so that the minimum and maximum numerical values for the lower and upper limit values in both the measurement range and engineering range are inverted.

● **About measurement range and engineering range setup**

These items must be set in the case of input range codes 100, 101, 102 and 105.
(When other range codes are set, the setup mode is not migrated to.)

PV is calculated by the following formula:

$$(PV) = \frac{(\text{engineering range upper limit value}) - (\text{engineering range lower limit value})}{(\text{measurement range upper limit value}) - (\text{measurement range lower limit value})} \times \{(\text{input value}) - (\text{measurement range lower limit value})\} + (\text{engineering range lower limit value}) + (\text{PV bias})$$

[Setup Example 1]

Item	Input Value	Description
Range code setting	105	-5 to +5 V
Measurement range upper value	5.000	
Measurement range lower value	1.000	When 0.0 to 2500.0 kPa is assigned to the voltage input value of 1 to 5 V.
Engineering range upper value	2500.0	
Engineering range lower value	0.0	
Engineering unit	kPa	

Indicated PV value when 2 V is input = 625.0 kPa

[Setup Example 2]

Item	Input Value	Description
Range code setting	105	-5 to +5 V
Measurement range upper value	3.200	
Measurement range lower value	1.200	When 0.0 to 2500.0 kPa is assigned to the voltage input value of 1.2 to 3.2 V.
Engineering range upper value	2500.0	
Engineering range lower value	0.0	
PV bias	-1000.0	
Engineering unit	kPa	

Indicated PV value when 2 V is input = 0.0 kPa

6 - 8 System Setup 3 (Scale Setup)

■ System Setup 3 (SYS LED blinks at 2-second intervals)

This is displayed when the extended menu is ON. (System setup 3 cannot be set unless the extended menu is ON.)

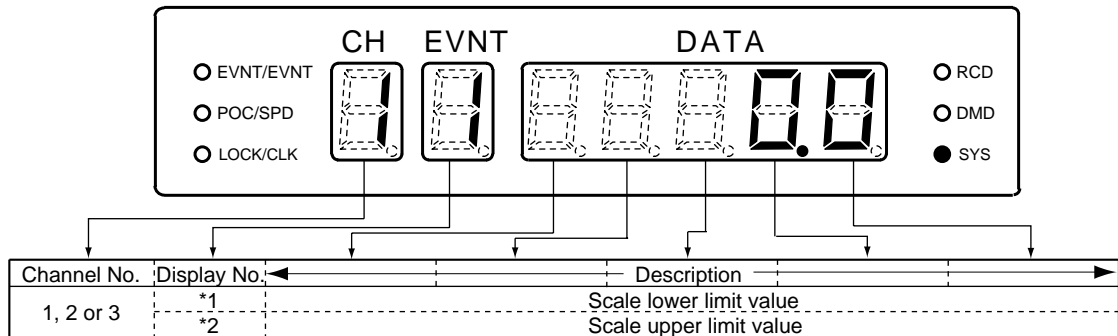

*: When the range code has been changed, the display will be initialized to match the range code. (In system setup 3, the scale lower and upper limit values are initialized to match the new range code, if the range code of system setup 2 is changed.)

! Handling Precautions

- The decimal point position of the scale is fixed.
Thermocouple, RTD input: See “6-9 Range Code Table” (page 6-17).
mV, V input: Refer to the engineering range decimal point position in system setup 2.
- Setting the same value to the lower and upper limit values results in an error, and setup is not possible.

● Setup Details

Scale upper/lower limits : “-19999 to +29999” (U)

■ Description of System Setup 3 Items

● About reverse scaling

Reverse scaling can be set so that the minimum and maximum numerical values for the lower and upper limit values are inverted.

(example)

Lower limit value becomes “+100.0” and upper limit value becomes “-100.0”.

● Minimum scaling range

Trend recording becomes stepped if scaling is set too narrow.

The resolution of trend recording in a 180 mm recording width is 1/3600.

Referring to “9-2 Input Types, Ranges and Display Accuracy” (page 9-5), set scaling so that a resolution higher than this is obtained.

● About scale setup

The recording scale lower and upper limit values are set as the chart 0% and 100% positions. For example, the range is -200.0 to +1370.0°C (input range code: 230) in the case of a K thermocouple. However, to set the left side (0% position) of the chart as “0.0°C” and the right side (100% position) of the chart as “1000.0°C” when carrying out trend recording on the chart, set the scale lower limit value to “0.0” and the upper limit value to “1000.0”.

As the scale setup range is -19999 to +29999, this can be used to record specific zones. For example, in the above example, to write the trend of a K thermocouple on the right half of the chart, set the scale lower limit value to “-1000.0” and the upper limit value to “1000.0”.

[Example] K thermocouple Range code: 230 (-200.0 to +1370.0°C)

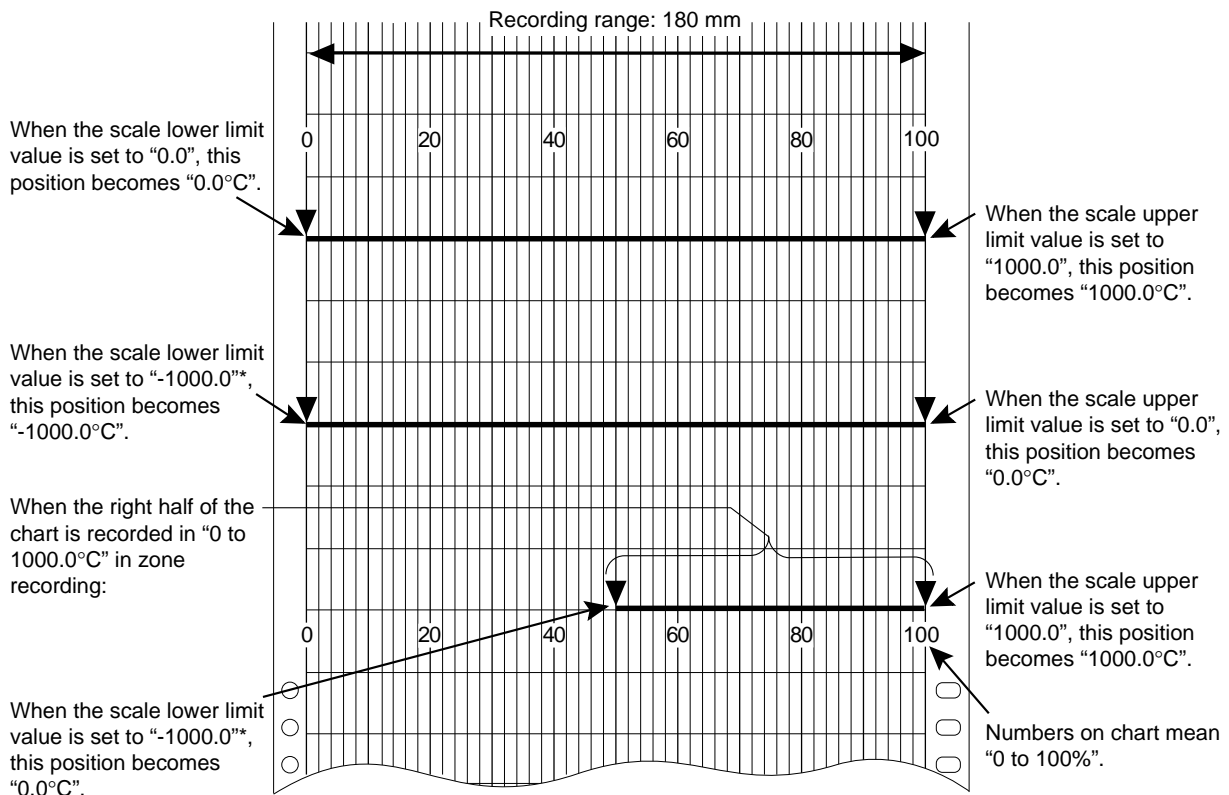

*: In the linear scale range, the decimal point becomes the value set in the range setup item.

! Handling Precautions

The scale setup range is -1999.9 to +2999.9.

6 - 9 Range Code Table

Type	Input		Range	
	Symbol	Code	mV/V input	mV/V indication range
DC voltage	mV	100	±14.00 mV	-19999 to +29999
		101	±25.00 mV	-19999 to +29999
		102	±70.00 mV	-19999 to +29999
	V	105	±5.000 V	-19999 to +29999
Thermocouple*	R	200	0.0 to 1760.0°C	
	S	210	0.0 to 1760.0°C	
	B	220	0.0 to 1820.0°C	
	K	230	-200.0 to +1370.0°C	
		231	-200.0 to +600.0°C	
		232	-200.0 to +300.0°C	
	E	240	-200.0 to +900.0°C	
		241	-200.0 to +350.0°C	
	J	250	-200.0 to +1100.0°C	
		251	-200.0 to +450.0°C	
	T	260	-200.0 to +400.0°C	
		261	-200.0 to +250.0°C	
	N	270	0.0 to 1300.0°C	
		271	0.0 to 700.0°C	
		272	0.0 to 350.0°C	
	WRe0-26	280	0.0 to 2320.0°C	
	WRe5-26	290	0.0 to 2320.0°C	
	PLII	310	-100.0 to +1390.0°C	
		311	-100.0 to +600.0°C	
		312	-100.0 to +300.0°C	
Ni-Ni•Mo	320	0.0 to 1310.0°C		
Resistance temperature detector (RTD)	Pt100 Ω	401	-200.0 to +300.0°C	
		402	-140.0 to +150.0°C	
		403	-140.0 to +100.0°C	
	JPt100 Ω	411	-200.0 to +300.0°C	
		412	-140.0 to +150.0°C	
		413	-100.0 to +100.0°C	

*: Display accuracy does not include reference contact compensation accuracy.

Chapter 6. DETAILED CONFIGURATION

Type	Symbol	Code	°F Range
Thermocouple*	R	500	32 to 3200°F
	S	510	
	B	520	32 to 3308°F
	K	530	-328 to +2498°F
		531	-328 to +1112°F
		532	-328 to +572°F
	E	540	-328 to +1652°F
		541	-328 to +662°F
	J	550	-328 to +2012°F
		551	-328 to +842°F
	T	560	-328 to +752°F
		561	-328 to +482°F
	N	570	32 to 2372°F
		571	32 to 1292°F
		572	32 to 662°F
	WRe0-26	580	32 to 4208°F
	WRe5-26	590	32 to 4208°F
	PLII	610	-148 to +2534°F
611		-148 to +1112°F	
612		-148 to +572°F	
Ni-Ni•Mo	620	32 to 2390°F	
Resistance temperature detector (RTD)	Pt100 Ω	701	-328.0 to +572.0°F
		702	-220.0 to +302.0°F
		703	-148.0 to +212.0°F
	JPt100 Ω	711	-328.0 to +572.0°F
		712	-220.0 to +302.0°F
		713	-148.0 to +212.0°F

*: Display accuracy does not include reference contact compensation accuracy.

6 - 10 Character Code Table

Lower Upper	0	1	2	3	4	5	6	7	8	9	A	B	C	D	E	F
2	(blank)	!	"	#	\$	%	&	'	()	*	+	,	-	.	/
3	0	1	2	3	4	5	6	7	8	9	:	;	<	=	>	?
4	@	A	B	C	D	E	F	G	H	I	J	K	L	M	N	O
5	P	Q	R	S	T	U	V	W	X	Y	Z	[¥]	^	_
6	`	a	b	c	d	e	f	g	h	i	j	k	l	m	n	o
7	p	q	r	s	t	u	v	w	x	y	z	Ω	ϴ	μ	²	₂
8	³	°	°	•												

Setup Example:kPa

Step	Engineering Unit	Character Code
1	k	6B
2	P	50
3	a	61
4	(blank)	20
5	(blank)	20
6	(blank)	20

6 - 11 External Switch Inputs (Optional Function)

The following functions are set to external switch inputs before the SRF201/202/203 is shipped from the factory. These functions cannot be changed on the SRF201/202/203 alone. You can, however, set any of the following functions using the Smart Handy Loader (SHL100) and the program data card for the SRF201/202/203.

Default function assignments:

RSW1 recording start/stop	Recording is started by OPEN → CLOSE. Recording is stopped by CLOSE → OPEN.
RSW2 demand printing	Demand printing is started by OPEN → CLOSE.
RSW3 chart feed	Chart is fed 40 mm by OPEN → CLOSE.
RSW4 print message 1	Printing (MSG1) is started by OPEN → CLOSE.

The following functions can be selected by using the Smart Handy Loader (SHL100):

Recording start/stop	Recording is started by OPEN → CLOSE. Recording is stopped by CLOSE → OPEN.
Demand printing	Demand printing is started by OPEN → CLOSE
Chart feed	Chart is fed 40 mm by OPEN → CLOSE.
Print message 1	Printing is started by OPEN → CLOSE.
Print message 2	Printing is started by OPEN → CLOSE.
Print message 3	Printing is started by OPEN → CLOSE.
Print message 4	Printing is started by OPEN → CLOSE.

! Handling Precautions

- Maintain external switch input ON/OFF states for at 500 ms or more.
- To prevent malfunction caused by noise, changes in state are not detected unless they last for 500 ms or more.

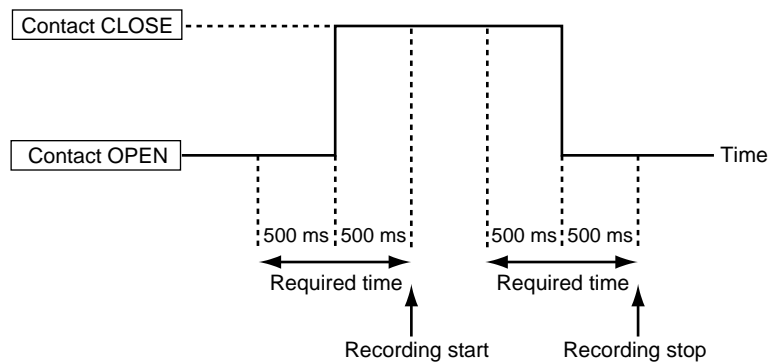

6 - 12 Printing of Messages

Message printing functions when the SRF201/202/203 supports external switch inputs (optional function). Message printing is started up by external switch input.

By message printing, the time (hours:minutes) and message (up to six characters) are printed.

To change the details set to a message, you will need the Smart Handy Loader (SHL100). The following table shows factory settings:

Message No.	Printed Details
1	MSG1
2	MSG2
3	MSG3
4	MSG4

You can set any message you like up to six characters long using the Smart Handy Loader (SHL100). Set the message referring to “**6-10 Character Code Table**” (page 6-18).

6 - 13 About Digital Printing Priority

Digital printing on the SRF201/202/203 is subject to several restrictions to ensure that trend recording is not interrupted. This is called “printing control.” The following briefly describes printing control.

■ Printing Control during a Print Conflict

Digital printing is categorized into the following four groups. In principle, printing is carried out in the order in which it occurs within each group. However, start of printing is sometimes suppressed or printing is canceled midway according to the type of printing. If printing of one group conflicts with printing of another, either printing of one of the groups is suppressed or one of the groups is printed over the other. The following describes these restrictions.

Print Group	Print Item	Restrictions
A	Event	
B	Initial printing	
	Demand	
	Message	
	Schedule demand	Printing is canceled when demand printing occurs (even during print standby).
	Tabulation	
	Scale	Printing of this item is not started up when other printing is currently in progress or standing by.
	Channel No.	Printing of this item is not started up when other printing is currently in progress or standing by.

! Handling Precautions

- Printing is canceled when printing conflicts with the scale upper limit and the TAG/UNIT and A or D of the scale.
- When two or more schedule demands are registered, and schedule demand printing is currently in progress or standing by, startup of the remaining schedule demand is not accepted even if the startup time is reached.

■ Simultaneous Printing Control

When demand printing and message printing or schedule demand printing and message printing continuously stand by to be printed, a message is printed on the hours:minutes line of demand printing (manual demand and schedule demand). This, however, does not apply in the following instances:

- When message printing is started during demand printing (or, vice versa)
- When demand printing (or, message printing) is started anew in a simultaneous printing state

Chapter 7. MAINTENANCE

7 - 1 Periodic Inspection

To ensure prolonged use of the SRF201/202/203, periodically inspect the operating status of the SRF201/202/203 and maintain it in a proper working condition. Perform the following inspections, and replace consumables and maintenance parts as required.

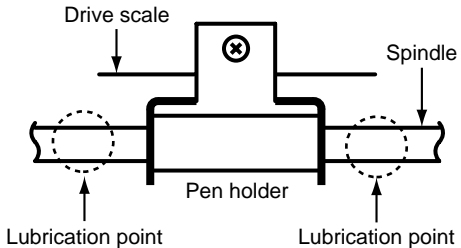
Inspection Item	Remedy	See page
Faint recording or printing	Replace the pen when recording is faint. Trend pen life: Approx. 2,500 m Printing pen life: Approx. 80,000 characters	4-1
Incorrect feeding of chart, paper jam	Re-load the chart.	4-1
Insufficient remaining chart	The remaining amount of chart is printed at 10 cm intervals on the right side of the chart. When only 60 cm of chart remains, the remaining chart warning is printed on the chart. Replace with new chart.	4-1
Lubrication of pen spindles	Lubricate the spindles with one or two drops of lubricating oil once every six months. Lubricate the printing pen and trend pen spindles, and the four spindles on the 3-pen model. After lubricating the spindles, lightly wipe the lubricating oil with a clean, dry cloth. ⚠ Handling Precautions <ul style="list-style-type: none"> • Before lubricating, be sure to turn the power OFF. • Before lubricating, wipe the spindle with a clean, dry cloth to wipe off any dirt. Recommended product: Kim Wipe® made by Crecia Co., Ltd. • Lubricate only the spindles. Never lubricate other parts. • Avoid forcibly moving pen holders to the left or right by hand. 	-
When dust is collecting on the door window	Wipe dust from the door window using soft dry cloth or paper. ⚠ Handling Precautions Never wipe the door window with paint thinner or other organic solvents. Doing so might cause the window to crack or cloud.	-

7 - 2 Measuring the Display Accuracy of Analog Inputs

This section describes how to measure the display accuracy of analog inputs. We recommend measuring the display accuracy of analog inputs once every year to ensure appropriate use of the SRF201/202/203.

If, as a result of measurement, it is found that accuracy deviates from the specified display accuracy of the SRF201/202/203, perform one-point adjustment using the PV bias. If the SRF201/202/203 needs to be calibrated, contact your dealer.



Note

For details on display accuracy, see “**9-2 Input Types, Ranges and Display Accuracy**” (page 9-5).

For details on PV bias, see “**6-7 System Setup 2 (Range Setup)**” (page 6-12).

■ Equipment Required for Measurement

The standard display accuracy of the SRF201/202/203 is 0.15%. When measuring the standard display accuracy, use equipment having an accuracy higher than this.

- DC standard voltage generator: When measuring DC voltage and thermocouple inputs
- Standard contact compensator (icebox): When measuring thermocouple inputs
- Dial variable resistor: When measuring resistance temperature detectors (RTD)

■ Measurement Environment

The standard display accuracy of the SRF201/202/203 is based upon the standard conditions listed in “**9-2 Input Types, Ranges and Display Accuracy**” (page 9-5). These conditions must also be satisfied when measuring the accuracy of analog inputs. If accuracy is measured outside of these conditions, the following additional accuracies must be included in the display accuracy measurement:

● Additional accuracies

(ambient temperature characteristics)

- Indication and recording fluctuations in response to temperature changes of $\pm 10^{\circ}\text{C}$:

(excluding standard contact temperature compensation error at thermocouple input)

Indication fluctuation: Within $\pm(0.1\% \text{ F.S.} + \text{resolution} \times 2)$

Recording fluctuation: Within (display fluctuation) + (0.5% F.S.)

(excluding influence of chart expansion/shrinkage)

(ambient humidity characteristics)

- When humidity changes from 60% to 85%RH:

Indication fluctuation: Less than $\pm 0.1\% \text{ F.S.}$

- When humidity changes from 60% to 45%RH:

Indication fluctuation: Less than $\pm 0.1\% \text{ F.S.}$

■ Procedure

- Wire to each of the input types as shown in the figure on the right, and warm up the SRF201/202/203 for at least 60 minutes.
- Make sure that the ambient temperature, humidity and other environmental conditions are within their respective standard conditions.
- Apply inputs equivalent to 0% and 100% of the input range, read the indications at this time, and measure the error from the difference with the input values.

● When measuring DC voltage

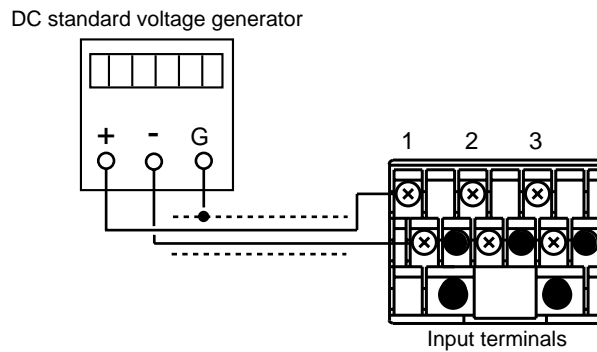

● When measuring a thermocouple

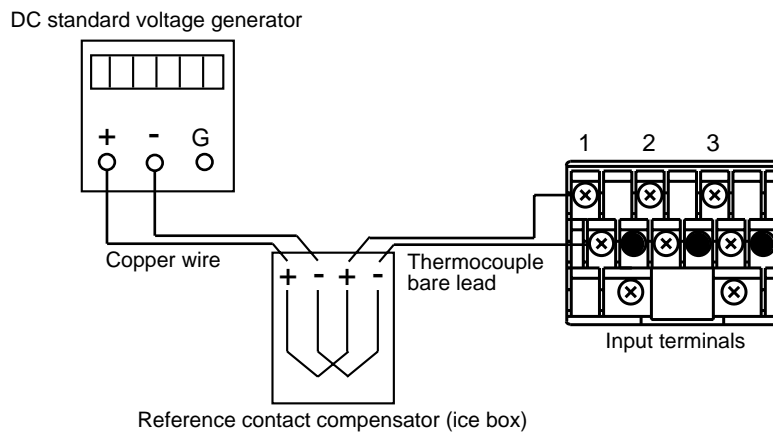

● When measuring a resistance temperature detector

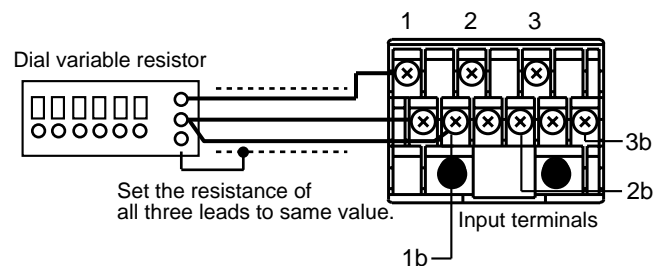

Chapter 8. TROUBLESHOOTING

8 - 1 Error Displays and Descriptions of Errors

The SRF201/202/203 is provided with a self diagnostics function that inspects the functions at all times. If an error has occurred, an error code is displayed on the display.

If two or more errors have occurred simultaneously, error codes are displayed successively from the lowest number upwards.

To cancel an error code display, remedy the error according to the following tables, and then turn the power OFF then ON again. If an error code stays displayed even though a remedy has been carried out, contact your dealer for repair.

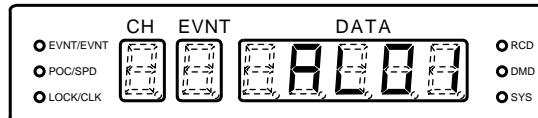

Error code	Diagnostic item	Description	Operation	Remedy
AL01	Trend pen error	The control unit of one or more trend pens is in error.	Recording can be continued using normal pens.	Contact your dealer for repair.
AL02	Printing pen error	The printing pen origin cannot be detected.	The origin is detected each time that printing is carried out. If the origin can be detected, printing is resumed, and trend recording can be carried out normally.	Check the printing pen or holder to see if any object is contacting or nipped by the pen or holder. If you cannot remedy this trouble, contact your dealer for repair.
AL03	Battery error	The battery for clock backup is worn.	<ul style="list-style-type: none"> • Date and time are reset to "98/01/01" and "00:00" respectively. • All indications other than the clock display are carried out normally. 	Contact your dealer for repair.
AL05	A/D error	A/D conversion is not carried out correctly.	<ul style="list-style-type: none"> • Data indication is "OL". • Recording exceeds upper limit. 	Contact your dealer for repair.



Handling Precautions

AL04 is omitted from the above table.

8 - 2 Remediating Trouble

Trouble	Probable Cause	Remedy
No operation (e.g. display, recording)	Power is not being supplied to the body.	Check the wiring and power voltage, and supply the power correctly.
	The power switch on the body is OFF.	Set the power switch at the bottom right on the body to ON.
	The fuse has blown.	Contact your dealer for repair.

Note 1: A probable cause is a damaged cable or connector between the chassis and body case.

Trouble	Probable Cause	Remedy
Pressing the  key does not advance the display to PV value display.	The recording mode for all channels is set to "display/recording OFF".	Set the recording mode for the required channels.
"ALXX" is displayed on the display.	An error was discovered during self diagnostics.	Follow the remedy described on page 8-1.
Recording is not carried out even though PV value display is normal.	The recording mode for all channels is set to "display only".	Set the recording mode for the required number of channels.
	Recording is not ON.	Press the  key to start recording.
	The pen cartridge has reached the end of its life.	Replace with a new pen cartridge. (See page 4-4.)
	The pen cartridge is not loaded.	Attach the pen cartridge. (See page 4-4.)
Digital printing is not carried out.	The chart cassette is not attached correctly.	Push the cassette in as far as possible, and press the load lever.
	The printing pen has reached the end of its life.	Replace with a new pen cartridge. (See page 4-4.)
	The printing pen is not loaded correctly.	Correctly load the printing pen. (See page 4-4.)
A chart speed at which digital printing is carried out is set.		Set the chart printing speed to 150 mm/h as necessary. (See page 4-4.)
Faint recording color	The pen has reached the end of its life.	Replace with a new pen. (See page 4-4.)
The chart is not being fed.	The chart cassette is not attached correctly.	Make sure that the chart holder spring and chart guide are correctly attached in place. Attach correctly if necessary. (See page 4-1.)
The chart has come loose from the sprockets.	The chart cassette is not attached correctly.	Make sure that the chart holder spring and chart guide are correctly attached in place. Attach correctly if necessary. (See page 4-1.)

Trouble	Probable Cause	Remedy
"OL", "-OL", "OF" or "-OF" is displayed at the PV display on the display.	An excessive voltage is being input.	Make sure that the signal voltage is correct. Enter the correct signal.
		Make sure that the signal voltage is correct. Set the correct range code.
		Check the polarities of the input terminals, and wire correctly if necessary.
	The wiring or sensor is broken.	Check the wiring from the sensor for breakages. Repair the sensor.
	The sensor or signal generator is malfunctioning.	Check the wiring from the signal oscillator for breakages. Repair the oscillator.
	The input impedance of equipment connected in parallel to the SRF201/202/203 has dropped.	Make sure that the sensor is not malfunctioning. Repair the sensor.
PV values using engineering scaling remain fixed values in spite of the input signal.	The engineering range upper limit value is set to the same value as its lower limit value.	Make sure that the signal generator is not malfunctioning. Repair the signal generator.
The PV display shows an error with the actual PV value.	The engineering range upper limit value is set to the same value as its lower limit value.	Make sure that the equipment connected in parallel to this recorder is not turned OFF. Turn the parallel-connected equipment ON.
	The PV bias is inappropriate.	Make sure that the equipment connected in parallel to this recorder is not malfunctioning. Repair the parallel-connected equipment.
Recording is 0% or less or 100% or more even though the PV display is correct.	The range code setting does not match the sensor.	Set the correct engineering range. (See page 6-14.)
	The PV bias is inappropriate.	Set the correct range code. (See page 6-17.)
Trend is stepped.	The scale setting is inappropriate.	Set the appropriate PV bias. To disable, set to "0" (zero). (See page 6-12.)
Pressing the ENT key in the configuration mode cannot set data.	The scale upper limit value is set to the same value as its lower limit value.	Set the scale matched to the input. (See page 6-15.)
	The scale span is far smaller than the resolution.	Set the correct scale. (See page 6-15.)
Pressing the SET key does not enter the range or scale setting mode.	Configuration is locked.	Set the scale as required. (See page 6-15.)
The recorder does not enter the event setting value display.	An attempt was made to enter illegal data.	Cancel the configuration lock. (See page 5-3.)
	The extended menu ON/OFF setting is OFF.	Enter data in the correct entry range.
The setting value of the event relay No. does not light.	The event type setting is set to "event OFF".	Set the extended menu ON/OFF setting to ON. (See page 5-3.)
Events are not recorded on the chart.	The event relay optional function is not supported.	Correct the event type setting. (See page 6-4.)
	The optional unit is malfunctioning.	Attach the add-on optional unit if necessary. (See page 1-3.)
The event switches ON/OFF continuously.	The event recording ON/OFF setting is set to "event recording OFF".	Repair
Characters are not printed on charts.	The event differential is too small.	Set the event recording ON/OFF setting to "event recording ON". (See page 6-4.)
	The chart feed speed is set to 150 mm/h.	Set the event differential to the appropriate value. (See page 6-4.)
		Set the chart feed speed to 151 mm/h or less.

Chapter 8. TROUBLESHOOTING

Trouble	Probable Cause	Remedy
PV values during demand printing or tabulation printing are all printed as "-----".	The recording mode of all channels is set to "display/recording OFF".	Set the recording mode for the required channels.
The recorder ID No. is not printed.	The recorder ID No. setting is "0".	Set the recorder ID No. to number other than "0" (zero). (See page 6-9.)
The time is not recorded.	The time recording ON/OFF setting is OFF.	Set the time recording ON/OFF setting to ON. (See page 6-9.)
Scale is not recorded.	The scale recording ON/OFF setting is OFF.	Set the scale recording ON/OFF setting to ON. (See page 6-9.)
The recording color does not match the tag plate.	The recording color selection setting does not match the tag plate.	Match the recording color selection to the tag plate. (See page 6-9.)
		Obtain a tag plate matched to the recording color selection. (See page 1-4.)
Schedule demand printing is not carried out.	The time setting interval is too short and cannot be printed.	Set the time setting to a wider value. (See page 6-10.)
		Decrease the number of demand printings. (See page 6-10.)
		Set the chart feed speed to a higher value. (See page 6-7.)
	The number of schedule demand ON/OFF settings is less than the time setting.	Match the number of schedule demand ON/OFF settings to the number of schedule demand time settings in use.
Handy Loader does not operate even if connected.	The cable is disconnected.	Replace the cable.
	The Handy Loader program card is not for this SRF201/202/203.	Slot the correct card into the Handy Loader.
	The Handy Loader battery is worn.	Replace the Handy Loader battery.
CPL communications is not possible.	The device address is set to "0".	Set the device address to an appropriate value other than "0". (See page 6-9.)
	The communications method of the SRF201/202/203 does not match the setting of the master instrument.	Match the communications method between this recorder and the master. (See page 6-9.)
	Inappropriate communications cable	Use an appropriate cable.
	Incorrect communications wiring	Rewire correctly. (See page 3-6.)
	Incorrect protocol	Change to the appropriate protocol.
Data from the master instrument cannot be written by CPL communications.	Communications access rights are set to "read only."	Set the communications access rights to "read/write" as necessary. (See page 6-9.)

Chapter 9. SPECIFICATIONS

9 - 1 Specifications

■ General Specifications

Memory protection	Setup data	EEPROM		
	Clock backup	Lithium cell (Battery life is about 10 years when the recorder is operated for 8 hours per day within temperature range of 0 to 40°C.)		
Vibration resistance	0.196 m/s ² max. (10 to 60 Hz)			
Insulation resistance	Min. 20 MΩ across each terminal and GND terminal (by 500V dc megger)			
Dielectric strength	Power supply, relay output, open collector output (leak current 5 mA max.):			
	Across power terminal and GND terminal:		1500V ac 50/60 Hz for 1 minute	
Induction resistance	Across relay output and GND terminal:		1500V ac 50/60 Hz for 1 minute	
	Input (leak current 2 mA max.)			
	Across measurement input terminal and GND terminal:		1000V ac 50/60 Hz for 1 minute	
	Across measurement input terminals:		500V ac 50/60 Hz for 1 minute (excluding RTD input)	
	Across external switch input terminal and GND terminal:		500V ac 50/60 Hz for 1 minute	
	Across communications terminal and GND terminal:		500V ac 50/60 Hz for 1 minute	
Standard conditions	Ambient temperature	23±2°C		
	Ambient humidity	60±5%RH		
	Voltage fluctuation	±1%		
	Frequency fluctuation	±1%		
	Vibration, noise, surge voltage	Not allowed		
	Influence from other equipment	Not allowed		
	Mounting angle	Horizontal		
Operating conditions	Ambient temperature	0 to 50°C		
	Ambient humidity	30 to 90%RH (condensation not allowed)		
Transportation/storage conditions	Ambient temperature	-20 to +60°C		
	Ambient humidity	5 to 95%RH (condensation not allowed)		
	Shock resistance	294 m/s ² (continuously for 11 ms max.)		
	Vibration resistance	4.9 m/s ² max. (10 to 60 Hz)		
Rated power voltage	100 to 240V ac, 50/60 Hz			
Allowable voltage fluctuation	90 to 250V ac, 50/60 Hz			
Power consumption	Approx. 40 VA			
Material	Case	Steel plate		
	Door frame	ABS resin		
	Door window	Acrylic resin		
Color	Case	Gray (Munsell N7 or equivalent)		
	Door frame	Gray (DIC555 or equivalent)		
Weight	W/out optional functions	No.1 pen: 7.9 kg	No.2 pen: 8.1 kg	No.3 pen: 8.4 kg
	W/ optional functions	No.1 pen: 8.2 kg	No.2 pen: 8.5 kg	No.3 pen: 8.7 kg
Mounting	Panel mount			
Mounting angle	Bottom rear angle to 30° and top rear angle to 3° from horizontal			

■ Performance Specifications

Input	Input type	<ul style="list-style-type: none"> Thermocouple/DC Voltage Groups Thermocouple: R, S, B, K, E, J, T, Ni-Ni•Mo, WRe0-26, WRe5-26, PLII, N DC voltage: -14 to +14 mV, -25 to +25 mV, -70 to +70 mV, -5 to +5 V RTD/DC Voltage Groups RTD: Pt 100 Ω, JPt100 Ω DC voltage: -14 to +14 mV, -25 to +25 mV, -70 to +70 mV, -5 to +5 V <p>Note 1) In the case of DC current (4 to 20 mA), attach a converter resistor of 250 Ω (sold separately, model No. 81446642-001 or 81401325), and convert to 1 to 5 V to input. Note 2) Externally attach one 1/1000 DC voltage divider input (sold separately, model No. 81446627-001) to each input that exceeds ±5 V for input. (max. input voltage: ±60 V)</p>	
	Number of input channels	1, 2, 3 (according to model No.)	
	Input measurement cycle	Approx. 125 ms	
	Input impedance	DC voltage, thermocouple input: 8 MΩ min.	
	Allowable wiring resistance	DC voltage, thermocouple input (input signal source resistor): 1 kΩ max. RTD input (input wiring resistor): 10 Ω max. per line	
	Burnout	None	
	Input bias current	DC voltage, thermocouple input: ±100 nA max.	
	Measuring current	RTD input: Approx. 2 mA	
	PV bias	Can be set to each channel in range -19999 to +29999 (engineering unit including decimal point).	
	Linear scaling	Display and recording is possible by actual unit (engineering unit) at DC voltage input.	
	Measurement/calculation method	PV value, inter-channel deviation, deviation from fixed value	
	Measurement range	DC voltage input: Any measurement range (upper/lower limit values) can be set for each of the measurement ranges.	
	Engineering range	DC voltage input: The engineering range (upper/lower limit value, decimal point position and unit) can be set within the range -19999 to +29999.	
	Recording scale	Any recording scale (including decimal point) can be set for each channel within the range -19999 to +29999.	
Reference contact compensation	Provided		
Intrinsically safe explosion-proof system	When an intrinsically safe system is required, connect a Zener barrier externally. If uneven resistance from the Zener barrier causes a temperature display error to occur, compensate for this by the PV bias. As the input wiring resistance exceeds 10 Ω, the accuracy compensation on page 9-5 cannot be applied.		
Display	Digital display	Display method	Red and green 7-digit, 7-segment LED (5-digits are green LEDs for displaying measurement values.)
		Display cycle	4s (channel refresh rate): 0.5s (data refresh rate)
		Display information	<ul style="list-style-type: none"> Measurement values (PV) Channel No. Alarm display Date Time (hours:minutes) Chart feed speed Other configuration data
Lamp display	Display information	<ul style="list-style-type: none"> Lights during recording and occurrence of an event. Lights and displays information in the configuration and operation modes. 	
Recorder	Recording method	Trend recording	Continuous printing by cartridge (disposable type) pen
		Digital printing	Dot printing by printing (disposable type) pen
		Pen balancing time	2s (recording paper movement from 0 to 100%)
		Pen positions	In order No.1 pen, No.2 pen, No.3 pen, printing pen from front (door side)
		Recording color	Trend recording: No.1 pen/red, No.2 pen/green, No.3 pen/blue Digital printing: Printing pen/purple
		Character structure	7 (V) x 5 (H) dot matrix
		Recording format	<ul style="list-style-type: none"> Trend recording Trend + tabulation recording Trend + schedule demand recording
		Character recording	Recording at chart feed speed of 150 mm/h or less

Recorder	Chart	Shape	Folding type
		Eff. recording width	-0.8 to +180.8 mm of calibration position (0%)
		Total length	20 m
		Replacement warning mark	Warning marks are output at 10 cm intervals from 60 cm from the end of the chart.
		Chart feed method	Stepping sprocket system
		Chart feed speed	1 to 599 mm/h, 10 to 200 mm/min
		Trend recording resolution	0.05 mm
		Recording accuracy	PV axis: Accuracy indicated in page 9-5 + ($\pm 0.5\%$ of recording full scale) (not including chart shrinkage) Time axis: ± 0.5 mm/1 m
	[Reference]	Chart shrinkage/elongation: When the ambient humidity has changed from 60% to 85%RH: → Chart stretches by approx. 0.7%FS. When the ambient humidity has changed from 60% to 45%RH → Chart shrinks by approx. 0.2%FS.	
	Display/recording mode	One of the following three modes can be selected and set for each channel: • Display/recording OFF • Display only • Display/recording ON	
Recording format	Trend recording	Trend	PV value (analog)
		Scale printing	• Marker/time (hours:minutes)/date/tag/scale unit Or, Marker/time (hours:minutes)/chart feed speed/tag/scale unit
		Event	• Channel No./time (hours:minutes)/event No./state (occurrence or reset) When an event occurs (is reset) before printing has finished, the next 48 items are stored to memory and printed.
	Trend + tabulation recording	Trend	PV value (analog)
		Scale printing	• Marker/time (hours:minutes)/date/tag/scale unit Or, Marker/time (hours:minutes)/chart feed speed/tag/scale unit • Scale upper- and lower-limit values
		Tabulation	• PV value (CH1, CH2, CH3 from left) Tabulation is carried out after printing of the scale. • Tabulation cycle Once every 40 to 80 mm
		Event	• Channel No./time (hours:minutes)/event No./state (occurrence or reset) When an event occurs (is reset) before printing has finished, the next 48 items are memorized and printed.
	Trend + schedule demand recording	Trend	PV value (analog)
		Scale printing	• Marker/time (hours:minutes)/date/tag/scale unit Or, Marker/time (hours:minutes)/chart feed speed/tag/scale unit • Scale upper- and lower-limit values
		Schedule demand	• Time (hours:minutes)/PV value (CH1, CH2, CH3 from left)
		Event	• Channel No./time (hours:minutes)/event No./state (occurrence or reset) When an event occurs (is reset) before printing has finished, the next 48 items are memorized and printed.

Event	Setting	Number of set events	2 events can be set for each channel.			
		Setting range	-19999 to +29999 (Decimal point position varies according to range.)			
		Differential gap	0 to 29999 (Decimal point position varies according to range.)			
	Action	Event action is carried out even while recording has stopped (RCD OFF). <ul style="list-style-type: none"> • PV upper limit • PV lower limit • Deviation upper limit • Deviation lower limit • Rate-of-change absolute value upper limit value • Rate-of-change absolute value lower limit value 				
	Action result	Recording	• Channel No. • Event occurrence/reset time • Event state • Relay output number (on relay output supported models)			
		Display	• Event state and measurement value when an event occurs • Event occurrence/reset state on other channels			
		Buffer	Up to 48 actions are stored to memory. (These are cleared when the power is turned OFF and recording is set to "OFF".)			
		Relay output	Optionally supportable as event output			
	Optional functions	External switch inputs	Number of inputs	4		
			Functions	<ul style="list-style-type: none"> • External switch input 1: Recording start/stop • External switch input 2: Demand printing • External switch input 3: Chart feed • External switch input 4: Message printing Above function assignments are fixed on body. However, the following functions can be freely assigned to each external switch input (1 function per external switch input) by the Smart Handy Loader in addition to the above functions. <ul style="list-style-type: none"> • Message 2 • Message 3 • Message 4 		
Contact hold time			500 ms min.			
Switch type			Dry contact or open collector			
Allowable open collector ON residual voltage			3 V max. (under recommended operating conditions)			
Allowable open collector OFF leakage current			100 µA max. (under recommended operating conditions)			
Open voltage			Approx. 5 V			
Short-circuit current			Approx. 1.6 mA			
Relay outputs			Number of outputs	6		
			Output action	2 event actions (max. 6 actions) preset to each channel can be freely combined to select OR output.		
		Output type	Transfer contact (NC, NO contact). Event relay excitation is forward action.			
		Contact rating	100V ac, 0.2 A, 30V dc, 0.3 A (max. allowable contact voltage 125V ac, 110V dc) Min. load 10 mV, 10 mA			
		Electrical life	100,000 operations (resistive load)			
Communications		Communications standard	Standard	RS-232C	RS-485	
			Number of signal lines	3 (including SG)	5 (including SG)	
			Transmission distance	15 m max.	300 m max.	
		Protocol	Standard	Yamatake Corporation CPL communications	Yamatake Corporation CPL communications	
			Network	1-1	Multi-drop (max. 31 nodes)	
			Function	Slave instrument function	Slave instrument function	
		Communications method	Master instrument	Not specified		
			Synchronization	Start-stop synchronization	Start-stop synchronization	
			Communications flow	Half duplex	Half duplex	
	Transmission speed		4800, 9600 bps	4800, 9600 bps		
	Data length		8 bits	8 bits		
	Parity		Even parity, no parity	Even parity, no parity		
Stop bit	1 stop bit, 2 stop bits	1 stop bit, 2 stop bits				

9 - 2 Input Types, Ranges and Display Accuracy

Input			Range		Display Accuracy	Resolution
Type	Symbol	Code	mV/V input	mV/V indication range		
DC voltage	mV	100	±14.00 mV	-19999 to +29999	± (0.2% of FS+1 digit)	10 µV
		101	±25.00 mV	-19999 to +29999	± (0.2% of FS+1 digit)	10 µV
		102	±70.00 mV	-19999 to +29999	± (0.2% of FS+1 digit)	10 µV
	V	105	±5.00 V	-19999 to +29999	± (0.2% of FS+1 digit)	1 mV
Type	Symbol	Code	°C Range		Display Accuracy	Resolution
Thermo-couple*	R	200	0.0 to 1760.0°C		± (0.3% of FS+1 digit) or 1°C whichever is larger	0.1°C
	S	210				
	B	220	0.0 to 1820.0°C		Less than 400°C ±50°C ± (0.3% of FS+1 digit) or 1°C whichever is larger	Not specified 0.1°C
	K	230	-200.0 to +1370.0°C		± (0.3% of FS+1 digit) or 1°C whichever is larger	0.1°C
		231	-200.0 to +600.0°C			
		232	-200.0 to +300.0°C			
	E	240	-200.0 to +900.0°C		± (0.3% of FS+1 digit) or 1°C whichever is larger	0.1°C
		241	-200.0 to +350.0°C			
	J	250	-200.0 to +1100.0°C		± (0.3% of FS+1 digit) or 1°C whichever is larger	0.1°C
		251	-200.0 to +450.0°C			
	T	260	-200.0 to +400.0°C		± (0.3% of FS+1 digit) or 1°C whichever is larger	0.1°C
		261	-200.0 to +250.0°C			
	N	270	0.0 to +1300.0°C		± (0.3% of FS+1 digit) or 1°C whichever is larger	0.1°C
		271	0.0 to +700.0°C			
		272	0.0 to +350.0°C			
	WRe0-26	280	0.0 to +2320.0°C		± (0.3% of FS+1 digit) or 1°C whichever is larger	0.1°C
	WRe5-26	290	0.0 to +2320.0°C		± (0.3% of FS+1 digit) or 1°C whichever is larger	0.1°C
	PLII	310	-100.0 to +1390.0°C		± (0.3% of FS+1 digit) or 1°C whichever is larger	0.1°C
311		-100.0 to +600.0°C				
312		-100.0 to +300.0°C				
Ni-Ni•Mo	320	0.0 to 1310.0°C		± (0.3% of FS+1 digit) or 1°C whichever is larger	0.1°C	
Resistance temperature detector	Pt100 Ω	401	-200.0 to +300.0°C		± (0.3% of FS+1 digit) or 1°C whichever is larger	0.1°C
		402	-140.0 to +150.0°C			
		403	-100.0 to +100.0°C			
	JPt100 Ω	411	-200.0 to +300.0°C		± (0.3% of FS+1 digit) or 1°C whichever is larger	0.1°C
		412	-140.0 to +150.0°C			
		413	-100.0 to +100.0°C			

*Thermocouple: Display accuracy does not include reference contact compensation accuracy.

Note

Reference contact compensation accuracy (at 0°C input);

- Type: K, E, J, T, PLII, N: ±0.5°C/±1°F
- Type: R, S, B, WRe0-26, WRe5-26, Ni-Ni•Mo: ±1°C/±2°F

Chapter 9. SPECIFICATIONS

Type	Symbol	Code	°F Range	Display Accuracy	Resolution
Thermocouple*	R	500	32 to 3200°F	± (0.3% of FS+1 digit) or 1°F whichever is larger	1°F
	S	510			
	B	520	32 to 3308°F	Less than 752°F ±90°F 1112°F min. ± (0.3% of FS+1 digit)	1°F
	K	530	-328 to +2498°F	± (0.3% of FS+1 digit) or 1°F whichever is larger	1°F
		531	-328 to +1112°F		
		532	-328 to +572°F		
	E	540	-328 to +1652°F	± (0.3% of FS+1 digit) or 1°F whichever is larger	1°F
		541	-328 to +662°F		
	J	550	-328 to +2012°F	± (0.3% of FS+1 digit) or 1°F whichever is larger	1°F
		551	-328 to +842°F		
	T	560	-328 to +752°F	± (0.3% of FS+1 digit) or 1°F whichever is larger	1°F
		561	-328 to +482°F		
	N	570	32 to 2372°F	± (0.3% of FS+1 digit) or 1°F whichever is larger	1°F
		571	32 to 1292°F		
		572	32 to 662°F		
WRe0-26	580	32 to 4208°F	± (0.3% of FS+1 digit) or 1°F whichever is larger	1°F	
WRe5-26	590	32 to 4208°F	± (0.3% of FS+1 digit) or 1°F whichever is larger	1°F	
PLII	610	-148 to +2534°F	± (0.3% of FS+1 digit) or 1°F whichever is larger	1°F	
	611	-148 to +1112°F			
	612	-148 to +572°F			
Ni-Ni•Mo	620	32 to 2390°F	± (0.3% of FS+1 digit) or 1°F whichever is larger	1°F	
Resistance temperature detector	Pt100 Ω	701	-328.0 to +572.0°F	± (0.3% of FS+1 digit) or 1°F whichever is larger	0.1°F
		702	-220.0 to +302.0°F		
		703	-148.0 to +212.0°F		
	JPt100 Ω	711	-328.0 to +572.0°F	± (0.3% of FS+1 digit) or 1°F whichever is larger	0.1°F
		712	-220.0 to +302.0°F		
		713	-148.0 to +212.0°F		

9 - 3 External Dimensions

(unit: mm)

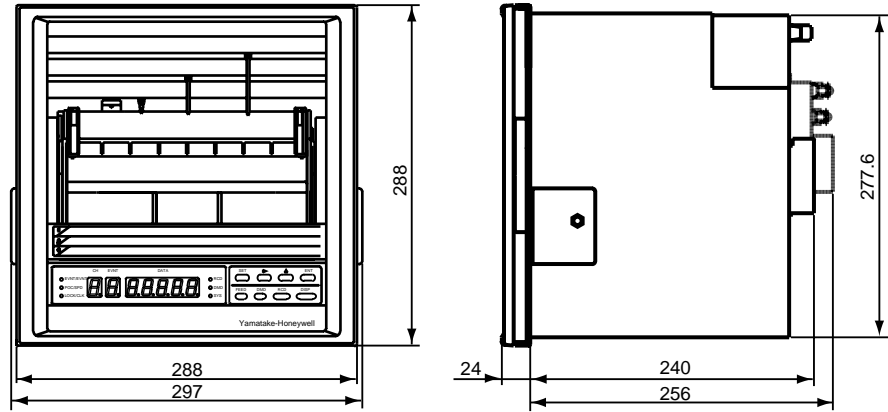

APPENDICES

User Setup Sheets

■ Appendix Contents

- Event Setup.....Appendix-2
- Chart Feed Speed Setup.....Appendix-2
- Date/Time SetupAppendix-2
- System Setup 1.....Appendix-2
- System Setup 2.....Appendix-4
- System Setup 3.....Appendix-4

■ How to Use the User Setup Sheets

The left page shows the setup details, and the right page shows the fields for entering the setting values. You might find it easier to make copies with both pages folded out.

APPENDICES

Customer	
Device Name	
Mfg. No.	

● **Event Setup**

- Setup details

Display No.	Setup Item	Setup Description	Factory Setting
1	No.1 event setting value	-19999 to +29999	0
2	No.2 event setting value	-19999 to +29999	0
3	No.1 event type selection	-, L, H, l, h, L., H.	0 (-): OFF
	No.1 relay output No.	0 to 6	0
	No.1 event recording ON/OFF	0 (OFF)/1 (ON)	1 (ON)
4	No.2 event type selection	-, L, H, l, h, L., H.	0 (-): OFF
	No.2 relay output No.	0 to 6	0
	No.2 event recording ON/OFF	0 (OFF)/1 (ON)	1 (ON)
5	No.1 event differential	0 to 29999	0
6	No.2 event differential	0 to 29999	0

● **Chart Feed Speed Setup**

- Setup details

Display No.	Setup Item	Setup Description	Factory Setting
1	Chart feed speed unit	0 (mm/h)/1 (mm/min)	0 (mm/h)
2	Chart feed speed	0 to 599 (mm/h)/10 to 200 (mm/min)	40

● **Date/Time Setup**

- Setup details

Setup Item	Setup Description	Factory Setting
Date		Close to Japan standard time
Time (hours:minutes)		Close to Japan standard time

● **System Setup 1**

- Setup details

Display No.	Setup Item	Setup Description	Factory Setting
1	Configuration lock	0 (OFF)/1 (ON)	0 (OFF)
2	Extended menu entry	0 (OFF)/1 (ON)	1 (ON)
3	Communications access rights selection	1 (read)/2 (read/write)	1 (read)
4	Device address	0 to 127 (setting to "0" inhibits communications)	0
	Communications method	1: 4800 bps, 8 bits even parity, 1 stop bit 2: 4800 bps, 8 bits no parity, 2 stop bits 3: 9600 bps, 8 bits even parity, 1 stop bit 4: 9600 bps, 8 bits no parity, 2 stop bits	1
5	Recording format selection	1 (trend)/2 (trend + tabulation)/3 (trend + schedule demand)	2 (trend + tabulation)
6	Recorder ID No.	0 to 99	0
7	Recording time ON/OFF	0 (OFF)/1 (ON)	1 (ON)
8	Scale recording ON/OFF	0 (OFF)/1 (ON)	1 (ON)
9	Pen phase synchronization setting	1/2/3	3 (pen phase synchronization OFF)
A	Schedule demand selection	0 (OFF)/1 (#1)/2 (#1, 2)/3 (#1, 2, 3)/4 (#1, 2, 3, 4)	0 (OFF)
b	No.1 schedule demand time	0:00 to 23:59	00:00
c	No.2 schedule demand time	0:00 to 23:59	00:00
d	No.3 schedule demand time	0:00 to 23:59	00:00
E	No.4 schedule demand time	0:00 to 23:59	00:00

Customer	
Device Name	
Mfg. No.	

- User Setup Field

Display No.	Check	Setup Item	Channel		
			1	2	3
1		No.1 event setting value			
2		No.2 event setting value			
3		No.1 event type selection			
		No.1 relay output No.			
		No.1 event recording ON/OFF			
4		No.2 event type selection			
		No.2 relay output No.			
		No.2 event recording ON/OFF			
5		No.1 event differential			
6		No.2 event differential			

- User Setup Field

Display No.	Check	Setup Item	Setting Value
1		Chart feed speed unit	
2		Chart feed speed	

- User Setup Field

Check	Setup Item	Setting Value
	Date	
	Time (hours:minutes)	

- User Setup Field

Display No.	Check	Setup Item	Setting Value
1		Configuration lock	
2		Extended menu entry	
3		Communications access rights selection	
4		Device address	
		Communications method	
5		Recording format selection	
6		Recorder ID No.	
7		Recording time ON/OFF	
8		Scale recording ON/OFF	
9		Pen phase synchronization setting	
A		Schedule demand selection	
b		No.1 schedule demand time	
c		No.2 schedule demand time	
d		No.3 schedule demand time	
E		No.4 schedule demand time	

APPENDICES

Customer	
Device Name	
Mfg. No.	

● System Setup 2

- Setup details

Display No.	Setup Item	Setup Description	Factory Setting
1	Recording mode selection	0 (OFF)/1 (display)/2 (display + recording)	2 (display + recording)
2	Range code	Selectable from all codes	105 (± 5 V)
3	Input calculation type	1 (PV)/ 2 (reference channel-own channel)/ 3 (own channel- reference channel)/ 4 (fixed value-own channel)/ 5 (own channel-fixed value)	1 (PV)
4	Reference channel	1 to 3	1
5	Measurement range lower limit	-19999 to +29999	1.000
6	Measurement range upper limit	-19999 to +29999	5.000
7	Engineering range decimal point	0 (xxxxx) to 4 (x.xxxx)	1 (xxxx.x)
8	Engineering range lower limit	-19999 to +29999	0.0
9	Engineering range upper limit	-19999 to +29999	100.0
A	Fixed value for deviation	-19999 to +29999	0
b	PV bias	-19999 to +29999	0
C	Engineering unit setting (UNIT)	6 characters	Blank

● System Setup 3

- Setup details

Display No.	Setup Item	Setup Description	Factory Setting
1	Scale lower limit	-19999 to +29999	0.0
2	Scale upper limit	-19999 to +29999	100.0

Customer	
Device Name	
Mfg. No.	

- User Setup Field

Display No.	Check	Setup Item	Channel		
			1	2	3
1		Recording mode selection			
2		Range code			
3		Input calculation type			
4		Reference channel			
5		Measurement range lower limit			
6		Measurement range upper limit			
7		Engineering range decimal point			
8		Engineering range lower limit			
9		Engineering range upper limit			
A		Fixed value for deviation			
b		PV bias			
C		Engineering unit setting (UNIT)			

- User Setup Field

Display No.	Check	Setup Item	Channel		
			1	2	3
1		Scale lower limit			
2		Scale upper limit			

Index

[A]

- AUTO indicator 4-7
- Absolute value deviation 6-4
- Absolute value deviation lower limit 6-4
- Absolute value deviation upper limit 6-4

[B]

- Basic key operations at setup 5-2
- Basic setup 6-9

[C]

- CLK indicator 4-7
- Character code 6-19
- Chart 4-1
- Chart cassette 2-1
- Chart feed 4-7
- Chart feed speed 5-5
- Chart feed speed setup 6-2, 6-7
- Chart feed speed, Changing the 5-5
- Chart guide 2-1, 4-2
- Chart holding spring 4-2
- Chart, Loading the 4-1
- Communications method 6-9
- Configuration items, To change 5-2
- Configuration lock 4-9
- Configuration lock, Canceling 5-3
- Configuration setup, To start 5-2
- Configuration unit 2-4
- Configuration, To quit 5-2
- Crimped solderless terminal 3-4

[D]

- DMD 2-3
- Data, To change 5-2
- Date/time setup 6-2, 6-8
- Date/time, Changing the 5-6
- Decimal point position 6-13
- Differential 6-4
- Differential gap 6-4
- Digital printing priority, About 6-22
- Display accuracy 9-5
- Display accuracy of analog inputs, Measuring the 7-2
- Display mode, Selecting the 4-7
- Display number, To advance to the next 5-2
- Display when an event occurs 4-9

[E]

- EVNT/EVNT 2-3, 2-4
- Engineering range 6-13, 6-14
- Error display 8-1
- Event buffer 6-6
- Event recording ON/OFF 6-6
- Event relay No. 6-6
- Event setting values, Changing 5-4
- Event setup 6-2
- Event setup 6-4
- Event type and operation 6-5
- Extended menu 5-1
- Extended menu ON/OFF, Switching the 5-3
- External dimensions 9-7
- External switch input 6-20
- External switch input, Connecting 3-7

[F]

- Factory setting 6-2
- Fixed value (event setup) 6-4
- Fixed value for deviation 6-12
- Front panel 2-1

[G]

- General specifications 9-1

[I]

- Initial printing 4-6
- Input calculation 6-13
- Input terminal, Connecting the 3-7
- Inside 2-1
- Installation dimensions 3-2
- Installation procedure 3-2

[L]

- LOCK/SPD 2-3, 2-4

[M]

- MAN indicator 4-7
- Measurement range 6-14
- Minimum scaling range 6-15
- Model listing 1-3

[N]

- Noise countermeasures 3-4

[O]

Operation display 2-3

Operation key 2-3, 2-4

[P]

POC/SPD 2-3, 2-4

PV bias 6-12

Parts No. 1-3

Pen life 4-5

Pen phase synchronization 6-10

Pen shaft, Lubricating the 7-1

Pens (pen tips), Distance between 6-11

Performance specifications 9-2

Periodic inspection 7-1

Power ON, Turning the 4-6

Power supply and ground, Connecting the 3-5

Print messages 4-10, 6-21

Printing control 6-22

Printing interval 6-7

Printing pen life 4-5

[R]

RCD 2-3

RS-232C Interface, Connecting the 3-9

RS-485 Interface, Connecting the 3-8

Range code 6-17

Range code selection 6-13

Range setup 6-12

Rate-of-change lower limit 6-4

Rate-of-change upper limit 6-4

Rear terminal 2-2

Recording ID No. 6-10

Recording mode 6-13

Recording, Starting/stopping 4-6

Relay contact rating 6-6

Relay output, Wiring 3-7

Resistance temperature detector input 3-6

Reverse scaling 6-13, 6-15

[S]

SYS 2-4

Scale setup 6-15

Schedule demand 6-11

Self diagnostic function 8-1

Siting conditions 3-1

Specific table, Recording a 4-8

Sprockets 4-2

System setup 1 6-2, 6-9

System setup 2 6-3, 6-12

System setup 3 6-3, 6-15

[T]

Tabulation recording interval 5-5

Thermocouple input 3-6

Time recording ON/OFF 6-10

Trend pen, printing pen setup 4-4

Trouble, Remediating 8-2

Specification are subject to change without notice.

YAMATAKE

Yamatake Corporation

Control Products Division

1-12-2, Kawana

Fujisawa, Kanagawa, 251-8522, Japan

Phone: 81-466-20-2187

Fax: 81-466-20-2309

This has been printed on recycled paper.

Printed in Japan.
1st Edition: Issued in Sep., 1998 (W)