

1. GENERAL DESCRIPTION:

The DCP552 Mark II DIGITRONIK Series is a microcomputer-based 2-loop general purpose program controller performing control of carbon potential (CP), temperature, pressure, gas flow rate, rotating speed, etc. of industrial processes.

2. MODEL NUMBERING SYSTEM:

Digit:	1	2	3	4	5	6	7	8	9	10	11	12
Model No.:	<u>D</u>	<u>C</u>	<u>P</u>	<u>5</u>	<u>5</u>	<u>2</u>	<u>A</u>	<u>2</u>	<input type="checkbox"/>	<input type="checkbox"/>	<input type="checkbox"/>	<input type="checkbox"/>
	[1]						[2]	[3]	[4]	[5]	[6]	

[1] Series Name DCP552: 2-channel digital control programmer (2-loop)

[2] ---- A: Mark II

[3] PV Input 2: PV input 2-channel

[4] Carbon Potential 0: None
 1: With

[5] Option 0: None
 1: Auxiliary output 1-channel
 2: Auxiliary output 2-channel, communication

[6] Additional Function 00: None
 D0: Inspection data attached
 Y0: Calibration certificate available

16	00
15	00
14	00
13	00
12	00
11	00
10	00
9	00
8	00
7	00
6	00
5	00
4	01
3	00
2	00
1	00

作成 DR. I.Harada		尺度 SCALE	記入のない公差 TOL. UNLESS NOTED
検図 CHK. H.Kato	形番 MODEL DCP552A (Mark II)		
認可 APPD. Kiikuniya	名称 NAME Digital Control Programmer		
日付 DATE 2-23-99	図番 NO. AD12902E	改番 REV. 01	1/16

01	JEO99-0647	9-20-99	M.Saito	N.Tomonari
改番 REV.	来歴 RECORD	日付 DATE	担当 BY	検閱 APPD.

SP. No.

Yamatake Corporation

製品仕様書
SPECIFICATIONS

• Thermocouple

Input Type			Input Range (FS)	Accuracy (under reference conditions)	
Symbol	Code	Range No.	Unit: °C		
K (CA)	K46	16	-200.0 ~ 200.0	±0.1%FS	
K (CA)	K09	0	0.0 ~ 1200.0	±0.1%FS	
K (CA)	K08	1	0.0 ~ 800.0	±0.1%FS	
K (CA)	K04	2	0.0 ~ 400.0	±0.1%FS	
E (CRC)	E08	3	0.0 ~ 800.0	±0.1%FS	
J (IC)	J08	4	0.0 ~ 800.0	±0.1%FS	
T (CC)	T44	5	-200.0 ~ 300.0	±0.1%FS	±0.3%FS at -200~-45°C
B (PR30-6)	B18	6	0.0 ~ 1800.0	±0.1%FS	±4.0%FS at 0~260°C, ±0.15%FS at 260~800°C
R (PR13)	R16	7	0.0 ~ 1600.0	±0.1%FS	
S (PR10)	S16	8	0.0 ~ 1600.0	±0.1%FS	
W (WRe5-26)	W23	9	0.0 ~ 2300.0	±0.1%FS	
W (WRe5-26)	W14	10	0.0 ~ 1400.0	±0.1%FS	
PR40-20	D19	11	0.0 ~ 1900.0	±0.2%FS	±0.9%FS at 0~300°C, ±0.5%FS at 300~800°C
N	U13	12	0.0 ~ 1300.0	±0.1%FS	
PLII	Y13	13	0.0 ~ 1300.0	±0.1%FS	
Ni-Ni/Mo	Z13	14	0.0 ~ 1300.0	±0.1%FS	
Au-Fe chromel	Z06	15	0.0 ~ 300.0K (K: Kelvin)	±0.4%FS	

作成 DR. I.Harada		尺度 SCALE	記入のない公差 TOL. UNLESS NOTED
検図 CHK. H.Kato	形番 MODEL	DCP552A (Mark II)	
認可 APPD. Kiikuniya	名称 NAME	Digital Control Programmer	
日付 DATE 2-23-99	図番 NO.	改番 REV. 00	2/16

頁 改番

改番
REV.来歴
RECORD

:

日付
DATE担当
BY検閲
APPD.日付 DATE
2-23-99図番
NO.

AD12902E

改番 REV.
00

2/16

SP. No.

Yamatake Corporation

製品仕様書
SPECIFICATIONS

• Resistance Thermometer Bulb

Input Type			Input Range (FS)	Accuracy (under reference conditions)	
Symbol	Code	Range No.	Unit: °C		
JIS'89Pt100 (IEC Pt100Ω)	F50	64	-200.0 ~ 500.0	±0.1%FS	
	F46	65	-200.0 ~ 200.0	±0.1%FS	
	F32	66	-100.0 ~ 150.0	±0.1%FS	
	F36	67	-50.0 ~ 200.0	±0.1%FS	
	F33	68	-40.0 ~ 60.0	±0.15%FS	
	F01	69	0.0 ~ 100.0	±0.15%FS	
	F03	70	0.0 ~ 300.0	±0.1%FS	
	F05	71	0.0 ~ 500.0	±0.1%FS	
JIS'89JPt100	P50	96	-200.0 ~ 500.0	±0.1%FS	
	P46	97	-200.0 ~ 200.0	±0.1%FS	
	P32	98	-100.0 ~ 150.0	±0.1%FS	
	P36	99	-50.0 ~ 200.0	±0.1%FS	
	P33	100	-40.0 ~ 60.0	±0.15%FS	
	P01	101	0.0 ~ 100.0	±0.15%FS	
	P03	102	0.0 ~ 300.0	±0.1%FS	
	P05	103	0.0 ~ 500.0	±0.1%FS	

作成 DR. I.Harada		尺度 SCALE	記入のない公差 TOL. UNLESS NOTED
検図 CHK. H.Kato	形番 MODEL	DCP552A (Mark II)	
認可 APPD. Kiikuniya	名称 NAME	Digital Control Programmer	
日付 DATE 2-23-99	図番 NO.	AD12902E	改番 REV. 00 / 3 / 16

頁

改番

改番
REV.来歴
RECORD

:

日付
DATE担当
BY検閱
APPD.日付 DATE
2-23-99図番
NO.

AD12902E

改番 REV.
00

3 / 16

SP. No.

Yamatake Corporation

製品仕様書 SPECIFICATIONS

• Current / Voltage

Input Type			Input Range (FS)	Accuracy (under reference conditions)	
Symbol	Code	Range No.			
mA (Linear)	C01	48	4~20mA	Programmable range -19999~20000 (Decimal point position movable)	±0.1%FS
	Z51	52	2.4~20mA		±0.1%FS
mV	M01	49	0~10mV		±0.1%FS
	L02	50	-10~10mV		±0.1%FS
		51	0~100mV		±0.1%FS
mA (Linear)	C01	128	4~20mA		Programmable range -19999~20000 (Decimal point position movable)
	Z51	134	2.4~20mA	±0.1%FS	
V (Linear)		129	0~1V	±0.1%FS	
		130	-1~1V	±0.1%FS	
	V01	131	1~5V	±0.1%FS	
		132	0~5V	±0.1%FS	
		133	0~10V	±0.1%FS	
O ₂ Sensor		135	0~1250mV Indication range (CP value): 0.000~4.000% C (PID control is effective within the range of 0.000~2.000% C)	±0.1%FS	At conversion into mV

Note 1: Unit of Code Z06 is K (Kelvin).

Note 2: In F50 and P50, PV lower limit alarm is not generated.

Note 3: Decimal point of DC current and voltage is movable from 0 ~ 4th place.

Note 4: In case of O₂ sensor, PV upper limit alarm is generated at 1375mV and over but PV lower limit is not generated.

Note 5: Any of the O₂ sensors made by NGK Insulators, Ltd., Marathon Monitors Co., Cambridge Co., Corning Co., AACCC(Advanced Atmosphere Control Corporation) Co., Harbor Colman Co., and Furnace Control Co. can be used.

Note 6: In case of CP model, PV2 becomes an exclusive use of O₂ sensor.

作成 DR. I.Harada		尺度 SCALE	記入のない公差 TOL. UNLESS NOTED
--------------------	--	----------	---------------------------

検図 CHK. H.Kato	形番 MODEL	DCP552A (Mark II)
-------------------	-------------	-------------------

認可 APPD Kiikuniya	名称 NAME	Digital Control Programmer
----------------------	------------	----------------------------

01	JEO99-0647 9-20-99	M.Saito	N.Tomonari
----	--------------------	---------	------------

改番 REV.	来歴 RECORD	日付 DATE	担当 BY	検閲 APPD.
---------	-----------	---------	-------	----------

日付 DATE 2-23-99	図番 NO.	AD12902E	改番 REV. 01	4/16
--------------------	-----------	----------	---------------	------

頁 改番

SP. No.

3. INPUT/OUTPUT COMPOSITION:

DCP552 Mark II Input and Output Signals

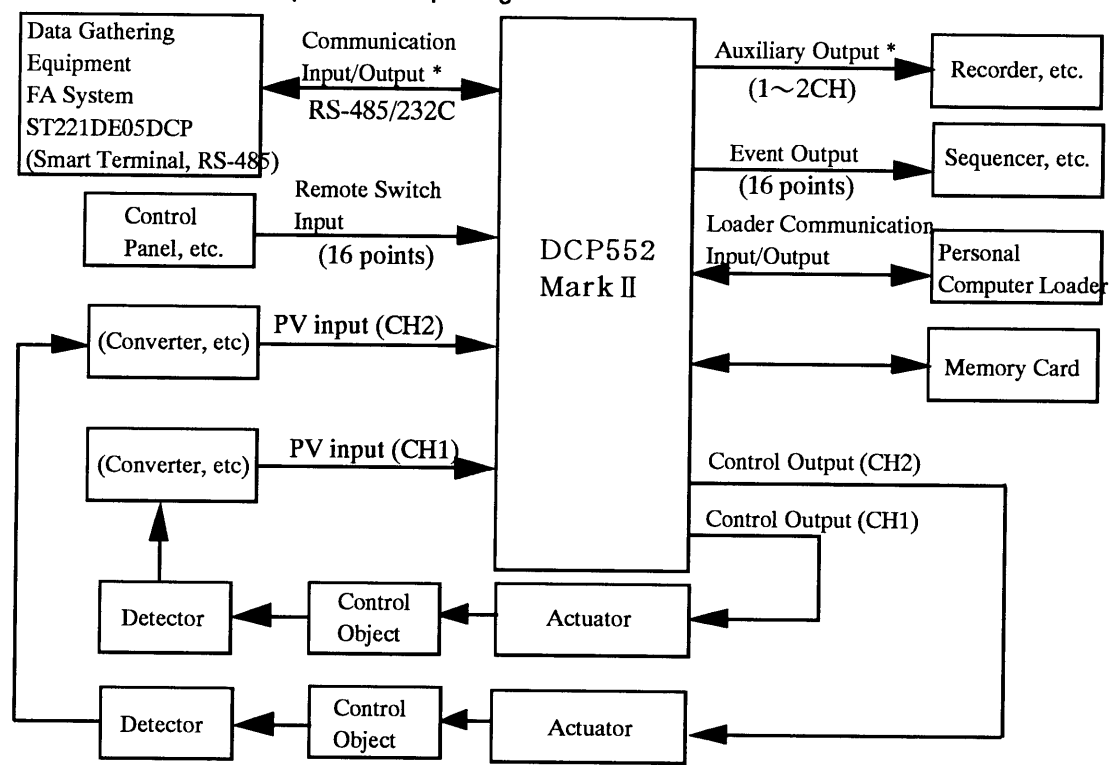

Note 4: * depends on Model No.

The following table shows the isolation among input/output signals:

Signals separated by boxes are isolated, but signals in a same box are not isolated.

PV Input CH1	CPU	Control Output CH1
		Auxiliary Output CH1
		Control Output CH2
		Auxiliary Output CH2
		Loader Communication Input/Output
		Event Output
PV Input CH2		
Remote Switch Input		
Communication Input/Output		
Memory Card I/F		

作成 DR. I.Harada	尺度 SCALE	記入のない公差 TOL. UNLESS NOTED
検図 CHK. H.Kato	形番 MODEL	DCP552A (Mark II)
認可 APPD KiiKuniya	名称 NAME	Digital Control Programmer
日付 DATE 2-23-99	図番 NO.	AD12902E
改番 REV.	改番 REV.	5/16

改番 REV.	来歴 RECORD	日付 DATE	担当 BY	検閲 APPD.
---------	-----------	---------	-------	----------

SP. No.

Yamatake Corporation

製品仕様書 SPECIFICATIONS

4. SPECIFICATION:

4.1 Program Pattern

Number of Program: 49 programs X 2 channels
 Number of Segments: 99 segments/program,
 2000 segments/one unit of this programmer

Segment Setting System:

- RAMP-X --- Segment setting system by set points (SP) and time.
- RAMP-T --- Segment setting system by set points (SP) and ramp (θ)
- RAMP-E --- Segment setting system by set points (SP) and set points per pulse (ΔSP) of remote setting input

The above three kinds of segments can exist in a same program pattern.

Time Setting Range:

0 ~ 500 hr. 00 minute, 0 ~ 500 minutes 00 second and 3000.0 seconds
 (time unit selectable)

Total Number of Sub-Functions: 4000 settings/one unit of this programmer
 (Sub-function means the settings of event, PID set selection, G. Soak, repeat and PV shift, which are settable per segment.)

作成 DR. I.Harada		尺度 SCALE	記入のない公差 TOL. UNLESS NOTED
検図 CHK. H.Kato	形番 MODEL	DCP552A (Mark II)	
認可 APPD Kiikuniya	名称 NAME	Digital Control Programmer	
日付 DATE 2-23-99	図番 NO.	AD12902E	改番 REV. 00

改番 REV.	来歴 RECORD	: 日付 DATE	担当 BY	検閲 APPD.
---------	-----------	-----------	-------	----------

6/16

SP. No.

Yamatake Corporation

製品仕様書 SPECIFICATIONS

4.2 Input

Indication Accuracy: $\pm 0.1\%FS$ (under reference conditions)
 However, may exceed this value in some ranges.
 (Refer to range table)

Cold Junction Accuracy; $\pm 0.5^{\circ}C$ (under reference conditions)

Input Sampling Period: 0.1 sec.

Influence of Wiring Resistance:

- Thermocouple --- $0.5\mu V/\Omega$
- DC Voltage (ranges less than 1V) --- $0.5\mu V/\Omega$
- DC Voltage (5V range) --- $3\mu V/\Omega$
- DC Voltage (10V range) --- $6\mu V/\Omega$
- Resistance temperature detector --- $\pm 0.05\%FS/\Omega$ max. within 0 ~ 10 Ω of total wire resistance

Burnout: Activate or non-activate selectable

Judgment of Range Over: Regarded as Up-scale at 110% FS and over
 Regarded as Down-scale at -10%FS and lower except F50 range
 (Burnout does not work in F50 range)

Digital Filter: 0.0 ~ 120.0 sec., adjustable (No filter at 0.0)

PV Bias: -1000 ~ 1000U, adjustable

Scaling: -19999 ~ 20000U, adjustable (possible only with linear input, reverse scaling possible, decimal point movable)

Root Extraction: Possible, dropout: 0.2 ~ 10.0% available in case of DC current and voltage ranges

PV Equalizer (Broken line approximation):

- PV1; 9 segments (10 break point settings)
- PV2; 9 segments (10 break point settings)
- CP; 9 segments (10 break point settings)

Notes: U (UNIT); Indication unit

Example: In 0.0 ~ 300.0 $^{\circ}C$ range, 1U means 0.1 $^{\circ}C$ and 100U means 10.0 $^{\circ}C$.

作成 DR. I.Harada		尺度 SCALE	記入のない公差 TOL. UNLESS NOTED
検図 CHK. H.Kato	形番 MODEL	DCP552A (Mark II)	
認可 APPD Kiikuniya	名称 NAME	Digital Control Programmer	
日付 DATE 2-23-99	図番 NO.	AD12902E	改番 REV. 00

改番 REV.	来歴 RECORD	: 日付 DATE	担当 BY	検閲 APPD.
------------	--------------	--------------	----------	-------------

SP. No.

Yamatake Corporation

製品仕様書 SPECIFICATIONS

4.3 Remote Switch Input

Number of Input Points: 16 points
 Output Type to be Connected: Dry contact or open collector
 Open Voltage: 8.5V±10% between common and each input/output terminal
 (under operation conditions)
 Allocation (fixed) : RUN, HOLD, RESET, ADV, Program No.,
 CH1 Operation Cancel, CH2 Operation Cancel
 Allocation (selectable) : RAMP-E, FAST, AT, AUTO/MANUAL,
 G.SOAK Cancellation, Auto Load, O₂ Sensor Check
 Input Sampling Cycle: 0.1s
 Min. Time Duration for ON Detection: 0.2s (Program No.: 0.4s)

4.4 Output

(1) Current Output

Type of Output: 4 ~ 20mA DC
 Load Resistance: 600Ω max. (under operation conditions)
 Output Updating Cycle: 0.1 sec.
 Output Accuracy: ±0.1% (under reference conditions)
 Output Resolution: 1/10000

(2) Voltage Output

Load Resistance: 600Ω max. (under operation conditions)
 Load Current Calibration: 2 ~ 22mA adjustable
 Time Proportioning Cycle: 1 ~ 240 sec. adjustable
 Output Resolution: 1/1000

(3) Open Collector Output

External Power Supply: DC 12 ~ 24V
 Maximum Load Current: DC100mA
 Time Proportioning Cycle: 1 ~ 240 sec. adjustable
 Output Resolution: 1/1000

頁 改番

改番 REV. 来歴 RECORD : 日付 DATE 担当 BY 検閲 APPD.

作成 DR. I.Harada		尺度 SCALE	記入のない公差 TOL. UNLESS NOTED
検図 CHK. H.Kato	形番 MODEL	DCP552A (Mark II)	
認可 APPD KiiKuniya	名称 NAME	Digital Control Programmer	
日付 DATE 2-23-99	図番 NO.	AD12902E	改番 REV. 00

8/16

SP. No.

Yamatake Corporation

製品仕様書 SPECIFICATIONS

4.5 Event Output Specification

Number of Event Points: 16 points
 Type of Output: Transistor open collector
 External Power Supply: DC12 ~ 24V
 Maximum Load Current: 70mA/point
 Maximum Common Current: 500mA

Type of Events:

PV --- PV, deviation, deviation with standby, absolute deviation, absolute deviation with standby, PV changing rate, SP, MV, G.SOAK absolute deviation, G.SOAK absolute deviation with standby, PV1 continuous operation, PV2 continuous operation

Time --- Time event, RAMP-E time monitoring, Segment time, Program time

Code --- Code event, Code event with timer, Program No. binary code, Segment No. binary code, Program No. BCD code, Segment No. BCD code

Mode --- Specific segment, RUN+HOLD+END+FAST, HOLD, READY+READY FAST, END, G.SOAK wait, MANUAL, During AT execution, FAST+READY FAST, Console setting operation, RUN, Advance, All alarm, PV range alarm, Instrument alarm, O₂ sensor abnormal, Low battery voltage

Event Hysteresis: For PV type, set 0 ~ 1000U
 Event On-delay: 0.0 to 3000.0 sec.
 Settable to 4 events

改番 REV.

改番

来歴 RECORD

日付 DATE

担当 BY

検閲 APPD.

作成 DR. I.Harada		尺度 SCALE	記入のない公差 TOL. UNLESS NOTED
検図 CHK. H.Kato	形番 MODEL	DCP552A (Mark II)	
認可 APPD Kiikuniya	名称 NAME	Digital Control Programmer	
日付 DATE 2-23-99	図番 NO.	AD12902E	改番 REV. 00 / 9 / 16

SP. No.

Yamatake Corporation

製品仕様書 SPECIFICATIONS

4.6 Auxiliary Output (Option)

Output Current: DC4 ~ 20mA
 Load Resistance: 600Ω max. (under operation conditions)
 Type of Auxiliary Outputs: SP1, PV1, Deviation 1, MV1, SP2, Deviation 2, O₂ Sensor mV Value
 Output Update cycle: 0.1 sec.
 Output Accuracy: ±0.1% (under reference conditions)
 Output Resolution: 1/10000

4.7 Control Constant

Number of PID Groups: 16 sets for program control
 (9 sets, selectable every segment + 7 sets, automatically selected by zone)
 PID Group Selection: By segment or automatic selection by zone selectable at program control
 Proportional Band (P): 0.1 ~ 1000.0%
 Reset Time (I): 0 ~ 3600 sec. (No integrating operation at I=0)
 Rate Time (D): 0 ~ 1200 sec. (No derivative operation at D=0)
 Manual Reset: 0.0 ~ 100.0%
 Output Limiter: Lo-limit -5.0 ~ high-limit
 Hi-limit Lo-limit ~ 105.0%
 Differential: 0 ~ 1000U (in ON-OFF control)
 Output Changing Rate Limit: 0.1 ~ 110.0% / 0.1s
 Control Action: Direct or reverse action selectable
 Auto-tuning: PID values are automatically set by the limit cycle method

作成 DR. I.Harada		尺度 SCALE	記入のない公差 TOL. UNLESS NOTED
検図 CHK. H.Kato	形番 MODEL	DCP552A (Mark II)	
認可 APPD Kiikuniya	名称 NAME	Digital Control Programmer	
日付 DATE 2-23-99	図番 NO.	AD12902E	改番 REV. 00 / 10 / 16

改番 REV.	来歴 RECORD	日付 DATE	担当 BY	検閲 APPD.
---------	-----------	---------	-------	----------

SP. No.

Yamatake Corporation

製品仕様書 SPECIFICATIONS

4.8 Time Accuracy

- Basic Time Accuracy: ±0.01%
- Time Delay in Operation:
 - 0 per segment advance
 - 0.1 sec. per one repeat function
 - 0.1 sec. per one cycle function

4.9 Memory Card Function

Program, PID and parameters (SETUP, PARA, event, etc.) data can be saved and loaded by a memory card (separate order)

Save: To copy the data of DCP to the card.

Load: To copy the data of card to DCP.

作成 DR. I.Harada		尺度 SCALE	記入のない公差 TOL. UNLESS NOTED
検図 CHK. H.Kato	形番 MODEL	DCP552A (Mark II)	
認可 APPD Kiikuniya	名称 NAME	Digital Control Programmer	
日付 DATE 2-23-99	図番 NO.	AD12902E	改番 REV. 00

改番 REV.	来歴 RECORD	:	日付 DATE	担当 BY	検閲 APPD.
---------	-----------	---	---------	-------	----------

SP. No.

Yamatake Corporation

製品仕様書 SPECIFICATIONS

4.10 Communication Function (Option)

Communication System: RS-485 or RS-232C

Network:

RS-485 --- Multidrop

Function of a slave station only except combination with ST221.

1:16max. (DIM)

1:31 max. (CMA, SCM)

RS-232C --- 1:1

The instrument has a slave station function only

Information Direction: Half-duplex

Sync. System: Start-stop sync.

Transmission system:

RS-485 --- Balanced type

RS-232C --- Unbalanced type

Data Line: Bit serial

Signal Line:

RS-485 --- 5-wire type (3-wire connection possible)

RS-232C --- 3-wire type

Communication Speed: 1200, 2400, 4800, 9600 bps selectable

Communication Distance:

RS-485 --- 500m max. (Total length)

300m max. when connected to MA500 DIM.

RS-232C --- 15m max.

Character: 11 bits/character

Format: 1 start, even parity, 1 stop or

1 start, no parity, 2 stop

Data Length: 8 bits

作成 DR. I.Harada		尺度 SCALE	記入のない公差 TOL. UNLESS NOTED
検図 CHK. H.Kato	形番 MODEL	DCP552A (Mark II)	
認可 APPD KiiKuniya	名称 NAME	Digital Control Programmer	
日付 DATE 2-23-99	図番 NO.	改番 REV. 00	12/16

改番 REV.	来歴 RECORD	: 日付 DATE	担当 BY	検閲 APPD.
---------	-----------	-----------	-------	----------

SP. No.

Yamatake Corporation

製品仕様書
SPECIFICATIONS

4.11 Other Functions

- Repeat Operation: To designate a segment to return. Setting is possible for each segment. (10,000 cycles max.)
- Cycle Operation: Setting possible for each program (10,000 cycles max.)
- Pattern Link: Connection of program patterns possible
- PV Shift: Setting of PV correction possible for each segment (-1000 ~ 1000U)
- Guaranty Soak: Setting of G. soak possible for each segment of program (segment start, end and whole segment)
G. soak width: 0 ~ 1000U, Setting possible for each segment.
- PV Start: Up, down, or both direction setting possible for each program.
- SP Bias: -1000 ~ 1000U
- SP Limiter: To limit the range of SP at program setting or execution.
- Operation Time Unit: Hour/minute, minute/second or 0.1 second selectable
- Manual Output: Balanceless bumpless changeover of AUTO and MANUAL possible
Preset manual output setting possible

作成 DR. I.Harada		尺度 SCALE	記入のない公差 TOL. UNLESS NOTED
検図 CHK. H.Kato	形番 MODEL	DCP552A (Mark II)	
認可 APPD Kiikuniya	名称 NAME	Digital Control Programmer	
日付 DATE 2-23-99	図番 NO.	AD12902E	改番 REV. 00

頁

改番

改番
REV.来歴
RECORD

:

日付
DATE担当
BY検閲
APPD.日付 DATE
2-23-99図番
NO.

AD12902E

改番 REV.
0013
16

SP. No.

Yamatake Corporation

製品仕様書
SPECIFICATIONS

5. GENERAL SPECIFICATIONS:

5.1 Operating Conditions

Ambient Temperature:	0 ~ 50°C (Ambient temperature of bottom surface of case when closely installed)
Ambient Humidity:	10 ~ 90%RH (Non-condensing)
Power Supply Voltage:	90 ~ 264V AC
Power Supply Frequency:	50±2Hz (At 50Hz power supply) 60±2Hz (At 60Hz power supply)
Vibration:	0 ~ 1.96m/s ²
Shock:	0 ~ 9.80m/s ²
Mounting Angle:	±10° from the reference plane (Vertical front face)

5.2 Shipping/Storage Conditions

Ambient Temperature:	-20 ~ +70°C
Ambient Humidity:	10 ~ 95%RH (Non-condensing)
Vibration:	0 ~ 4.9m/s ² (10 ~ 60Hz, for 2 hours each in X, Y and Z directions)
Shock:	0 ~ 490m/s ² (Top and bottom, 3 times, with packed condition)
Shipping Drop Test:	From 60cm height (1 corner, 3 edges radiating from the corner and all 6 sides, free drop)

5.3 Reference Conditions

Ambient Temperature:	23±2°C
Ambient Humidity:	60±5%RH
Power Supply Voltage:	105±1V AC
Power Supply Frequency:	50±1Hz (At 50Hz power supply) 60±1Hz (At 60Hz power supply)
Vibration:	0m/s ²
Shock:	0m/s ²
Mounting Angle:	±3° from the reference plane

作成 DR. I.Harada		尺度 SCALE	記入のない公差 TOL. UNLESS NOTED
検図 CHK. H.Kato	形番 MODEL	DCP552A (Mark II)	
認可 APPD Kiikuniya	名称 NAME	Digital Control Programmer	
日付 DATE 2-23-99	図番 NO.	AD12902E	改番 REV. 00

頁 改番

改番
REV.来歴
RECORD

:

日付
DATE担当
BY検閲
APPD.

日付 DATE

図番
NO.

AD12902E

改番 REV.

14
16

SP. No.

Yamatake Corporation

製品仕様書 SPECIFICATIONS

5.4 Other Specifications

Memory Backup:

Memory --- Battery backedup RAM

Battery --- Approx. 5 years with power OFF under reference conditions
Approx. 10 years with power ON under reference conditions

Power Consumption: 25VA max.

Inrush Current: 50A max.

Operation when Power Turned ON: Reset time 10s max.
(Time until normal operation under operation conditions)

Immune Time Interval Against Power Interruption: 20ms min.
(under operation conditions)

Insulation Resistance: Between power supply terminal and FG terminal;
50MΩ with a DC500V megger

Dielectric Strength: Between power supply terminal and FG terminal;
1500VAC 50/60Hz 1 min

Note 5: When perform dielectric test, disconnect potentially grounded secondary terminals (Ex. Thermocouple connected to ground) to avoid adverse effect caused by internal capacitance coupling between primary and secondary of this device.

Terminal Screw: M3.5 self-up screw

Terminal Screw Tightening Torque: 0.78 ~ 0.98N•m

Mask/Case Material: Mask; Multiron
Case; Multiron

Mask/Case Color: Mask; Dark gray (Munsell 5Y3.5/1)
Case; Light gray (Munsell 2.5Y7.5/1)

Mounting: Mount by a pair of dedicated mounting brackets

Mass (Weight): Approx. 1.5kg

作成 DR. I.Harada		尺度 SCALE	記入のない公差 TOL. UNLESS NOTED
検図 CHK. H.Kato	形番 MODEL	DCP552A (Mark II)	
認可 APPD Kiikuniya	名称 NAME	Digital Control Programmer	
日付 DATE 2-23-99	図番 NO.	AD12902E	改番 REV. 00 / 15 / 16

改番 REV.	来歴 RECORD	日付 DATE	担当 BY	検閲 APPD.
------------	--------------	------------	----------	-------------

SP. No.

Yamatake Corporation

製品仕様書
SPECIFICATIONS

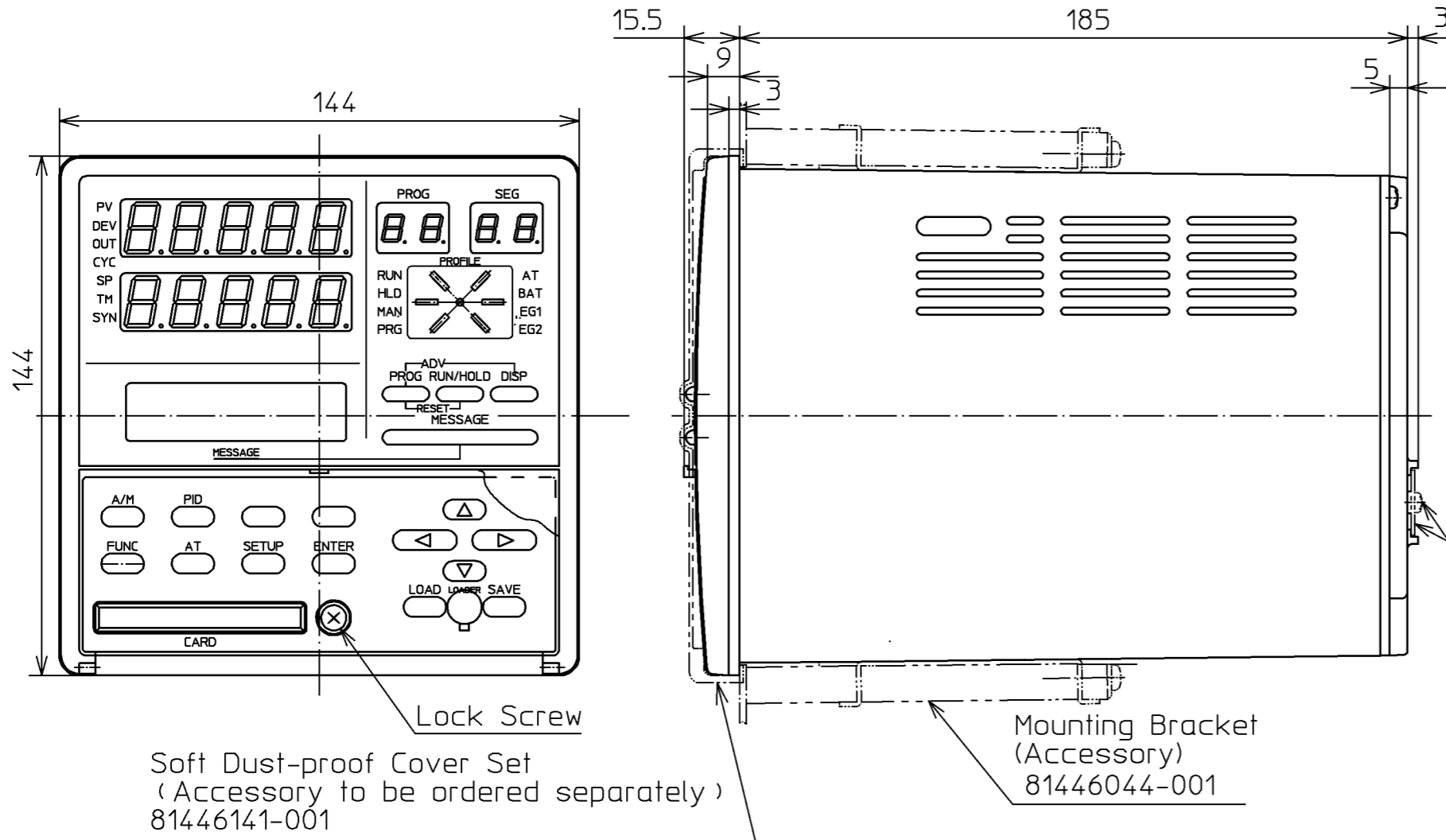

Soft Dust-proof Cover Set
(Accessory to be ordered separately)
81446141-001

Mounting Bracket
(Accessory)
81446044-001

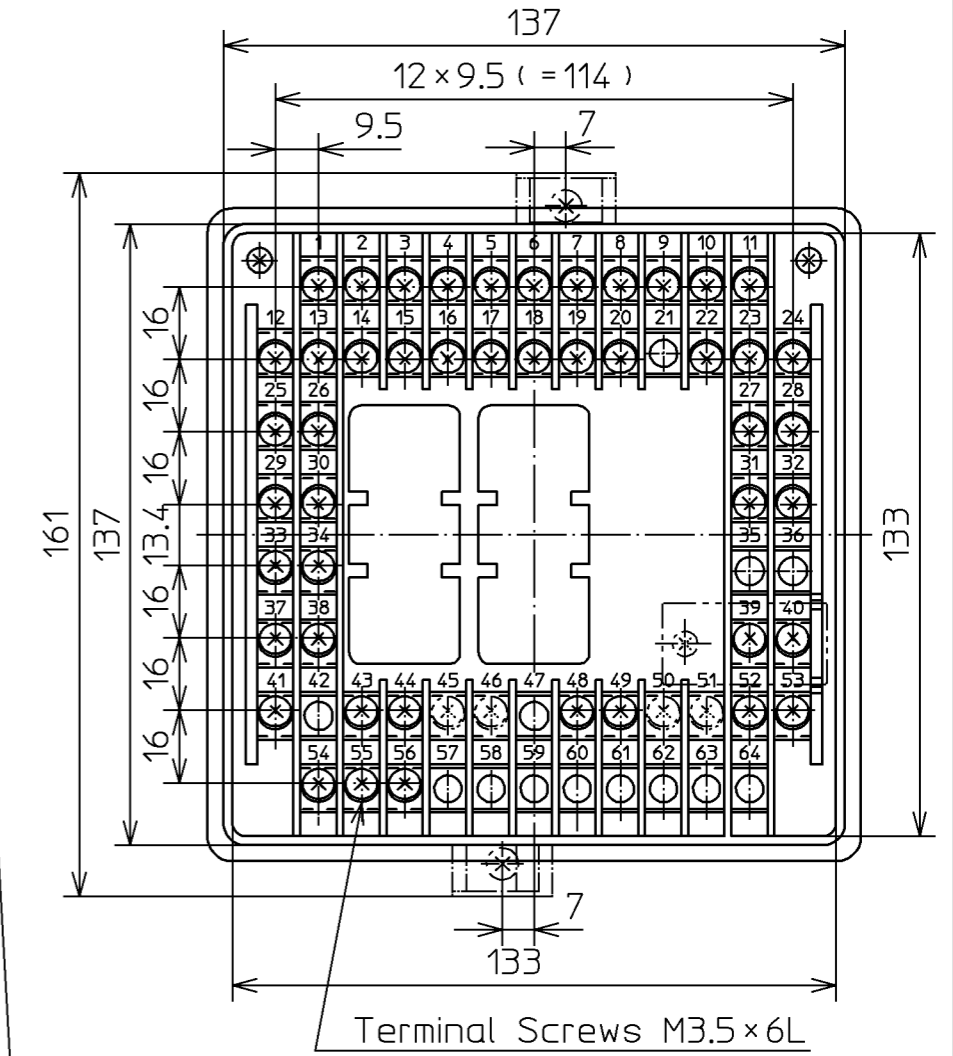

Terminal Cover Set (Accessory)
81446176-001

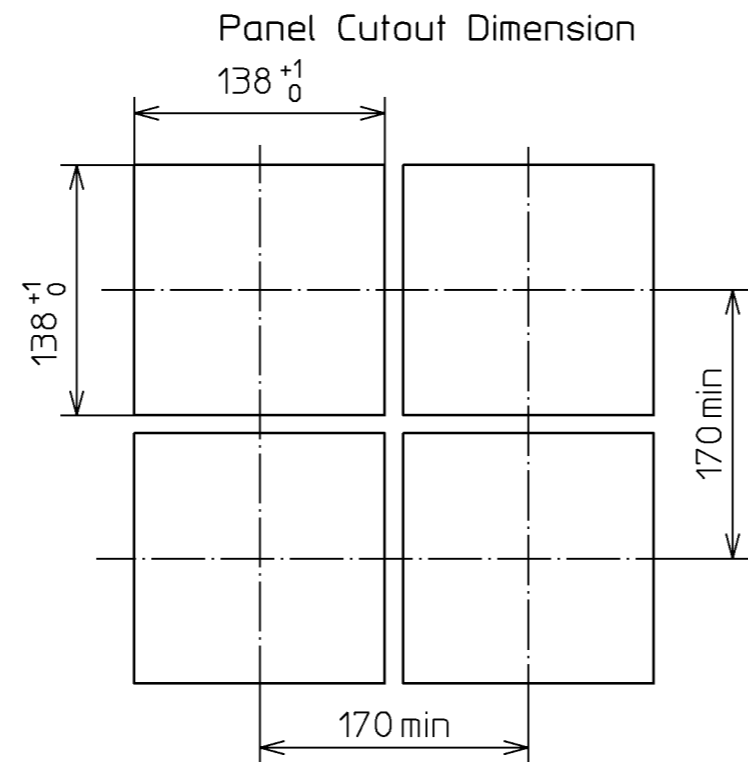

作成DR. T.Akimoto 2.12.'99	検図CHK. K.Murata 2.12.'99	認可APPD. K.Murata 2.12.'99	日付DATE 2.12.'99	来歴 RECORD	日付 DATE	担当 BY	検閲 APPD.	尺度SCALE mm	記入のない公差 TOL. UNLESS NOTED	形番 MODEL DCP552A(MarkII)	名称 NAME Digital Control Programmer	図番 NO. AD12902E	改番REV. 16/16
--------------------------------	--------------------------------	---------------------------------	--------------------	--------------	------------	----------	-------------	---------------	---------------------------	--------------------------------	--	-----------------------	-----------------