

DIGITRONIK™

Programmable Controller

DCP551B Mark II

The DIGITRONIK™ DCP551B Mark II is a high-function programmable controller supporting up to 99 program patterns to which thermocouple, resistance temperature detector (RTD), DC voltage, DC current and other signals can be input.

The DCP551B Mark II supports, 16 event outputs, 16 external switch inputs and a wide range of other functions as part of the standard specification; and communications and auxiliary output as option functions.



FEATURES

- Accuracy of $\pm 0.1\%FS$. Easy-to-view large display characters. Compact design
 - 2 PV input type also available
 - Any input type can be selected by console key operation.
 - Easy operation aided by guidance messages
 - Up to 99 program patterns can be stored and up to 99 segments can be programmed to each pattern.
 - Various events can be selected and set for the 16 event outputs, and code events comprising a combination of two or more points can be set.
 - 16 external switch inputs allow the control of remote selection of program Nos. or operation.
 - CE marking-compatible
- Applicable standards: EN61010-1, EN61326

BASIC FUNCTION BLOCKS of DCP551B Mark II

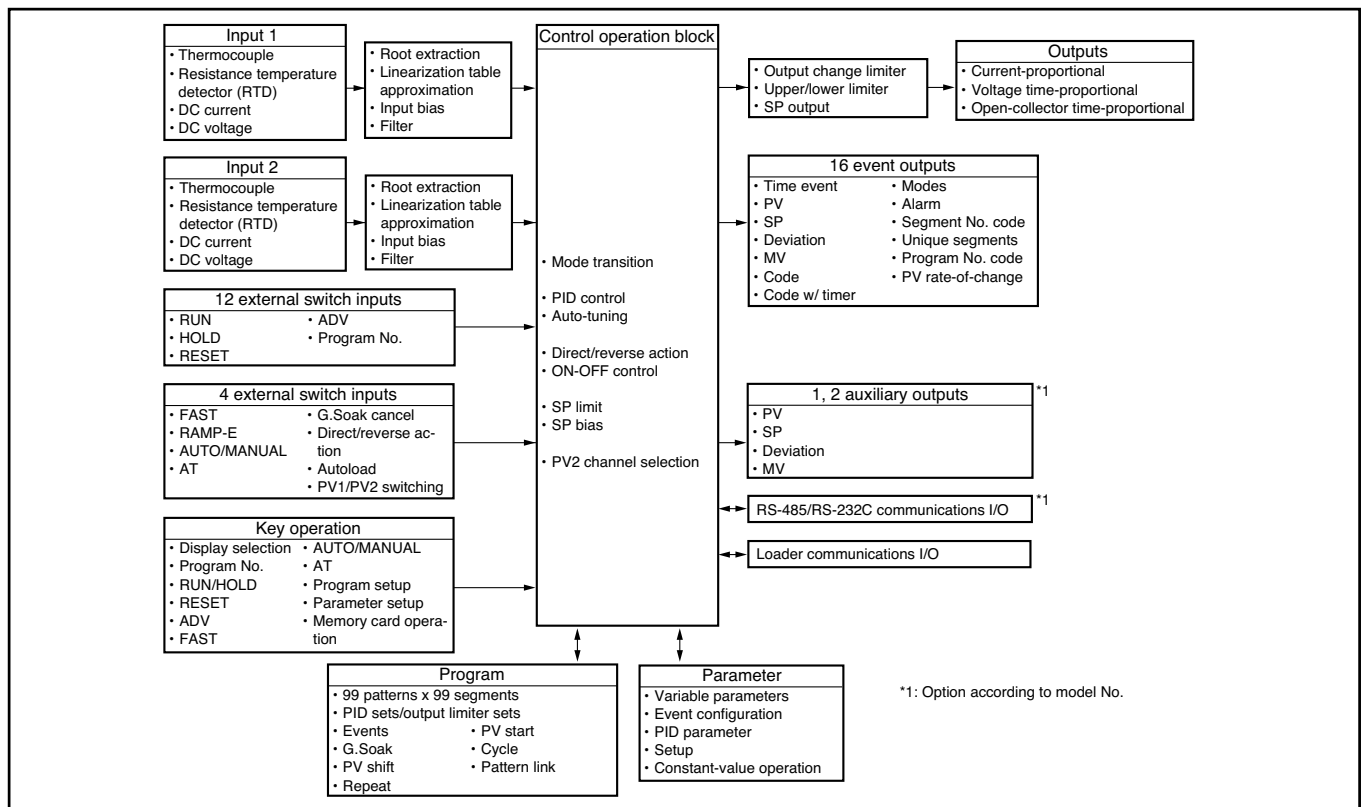

SPECIFICATIONS

Program	Number of programs	99
	Number of segments	99 per program, 2000 per controller
	Segment setting system	RAMP-X: Set by set points (SP) and time. RAMP-T: Set by set points (SP) and ramp (θ) RAMP-E: Set by set points (SP) and Δ SP per external switch input 1 pulse
	Segment time	0 to 500 hours 0 minute, 0 to 500 minutes 0 second, 0.0 to 3000.0 seconds (time unit selectable)
	Segment ramp	1 to 10000 U/hour, 1 to 10000 U/minute, 1 to 10000 U/second (time unit selectable)
	Segment ΔSP	1 to 10000 U/1 pulse
	Number of sub-functions	4000 settings per controller
	Sub-function action	Events, PID set, output limiter set, G.Soak, PV shift, repeat
	Events (16)	Set operating point corresponding to event type
	PID set No.	Set 0 (continuation of previous segment), 1 to 9, A set (automatically switched) and ON-OFF control
	Output limiter set	Set 0 (continuation of previous segment), 1 to 9
	G.Soak	Set type (start/end points and overall) and G.Soak width 0 to 1000 U.
	PV shift	-10000 to +10000 U
	Repeat	Set return destination segment No. and repeat count.
	PV start	Set type (rising/falling or both) for each program.
	Cycle	Set cycle count for each program.
	Pattern link	Set program No.0 to 99 (0: no link) for each program.
Tag	Set 8 alphanumeric or symbols for each program.	
Basic time accuracy	$\pm 0.01\%$ (segment time setting = 0, with 0.1 second delay for each repeat and cycle)	
Inputs	Input type	Thermocouple, resistance temperature detector (RTD), DC voltage, DC current multi-range (See pages 6, 7.)
	Sampling cycle	0.1 seconds
	Input bias current	Thermocouple, DC voltage input: Max. $\pm 1.3 \mu\text{A}$ (at peak value and reference conditions) 1 V or higher range: Max. $-3 \mu\text{A}$
	Input impedance	DC current input: approx. 50Ω (under operating conditions)
	Measuring current	RTD input: Approx. 1 mA current flow from terminal A (under operating conditions)
	Influence of wiring resistance	Thermocouple, DC voltage input: Thermocouple: $0.5 \mu\text{V}/\Omega$ DC voltage (max. 1 V range): $0.5 \mu\text{V}/\Omega$ DC voltage (5 V range): $3 \mu\text{V}/\Omega$ DC voltage (10 V range): $6 \mu\text{V}/\Omega$ RTD input: Max. $\pm 0.01\% \text{FS}/\Omega$ in wiring resistance range 0 to 10Ω Range of F01, F33, P01 and P33: $\pm 0.02\% \text{FS}/\Omega$ max.
	RTD input allowable wiring resistance	<ul style="list-style-type: none"> Ranges other than F01, F33, P01 and P33: 85Ω max. (including Zener barrier resistance. Note that site adjustment is required.) Ranges of F01, F33, P01 and P33: 10Ω max. (Zener barrier cannot be used.)
	Allowable parallel resistance	Thermocouple disconnection detection allowable parallel resistance: $1 \text{ M}\Omega$ min.
	Max. allowable input	Thermocouple, DC voltage input: -5 to $+15\text{V}$ dc DC current input: 50 mA dc, 2.5V dc
	Burnout	Detection selectable
	Over-range detection threshold	$110\% \text{FS}$ min.: Upscaled $-10\% \text{FS}$ max.: Downscaled (Note that F50 range is not downscaled.)
	Cold-junction compensation accuracy	$\pm 0.5^\circ\text{C}$ (under standard conditions)
	Cold- junction compensation system	Internal/external (0°C only) compensation selectable
	Scaling	-19999 to $+20000$ U (possible in case of linear input only. Inverse scaling possible. Decimal point position settable at any point)
	Square root extraction	Possible. Dropout: 0.2 to 10.0% in case of DC current or DC voltage range
	PV equalizer (linearization table approximation)	PV1: 9 segments (10 points set) PV2: 19 segments (20 points set)
	Input bias	-1000 to $+1000$ U variable
Digital filter	0.0 to 120.0 seconds variable (0.0: filter OFF)	

External switch inputs	Number of inputs	16	
	Types of connectable outputs	Dry contacts (relay contact) and open-collector (current sink to ground)	
	Terminal voltage (open)	8.5 V±0.5 V between common terminals (terminals ⑫, ⑭) and each input terminal (under operating conditions)	
	Terminal current (short-circuit)	Approx. 6 mA between each terminal (under operating conditions)	
	Allowable contact resistance (dry contact)	ON: 250 Ω max. (under operating conditions) OFF: 100 kΩ min. (under operating conditions)	
	Voltage drop (at open-collector ON)	2 V max. (under operating conditions)	
	Leakage current (at open-collector OFF)	0.1 mA max. (under operating conditions)	
	Parallel connection with other instruments	Can be connected to Yamatake Corporation SDC40 and SDC10 series	
	Assignments (fixed)	RUN, HOLD, RESET, ADV, program No.	
	Assignments (variable)	RAMP-E, FAST, AT, AUTO/MANUAL, G.Soak cancel, direct/reverse action, auto-load, PV1/2 switching	
	Input sampling cycle	0.1 seconds	
	ON detection min. hold time	0.2 seconds (0.4 seconds for program No.)	
	Indication/programmer	Upper display	Green 5-digit, 7-segment LED This displays PV values in the basic display state. Item codes are displayed in the parameter setup.
Lower display		Orange 5-digit, 7-segment LED This displays SP and output % in the basic display state. Setting values are displayed in the parameter setup.	
Program No. display		Green 2-digit, 7-segment LED This displays program No. in the basic display state.	
Segment No. display		Green 2-digit, 7-segment LED This displays segment No. in the basic display state. Item Nos. are displayed in parameter setup, and alarm No. is displayed when alarm occurs.	
Message display		This displays output graph, deviation graph, event state and tags in the basic display state. This displays reference messages in the parameter setup and program setup. This displays operation details and operation results of memory card operation.	
Profile display		7 orange LEDs Displays program pattern rise, soak and fall trends.	
Status displays		22 round LEDs Modes: RUN, HLD, MAN, PRG (green) Display details: PV, SP, OUT, TM, CYC, SYN, DEV (green) Battery voltage: BAT (red) (blinks at low voltage) Status: AT (green) Events: EG1, EG2 (red)	
Operation keys		18 rubber keys	
Loader connector port		1 (dedicated cable with stereo miniplugs)	
Modes	Program operation modes	READY:	Ready to run program (control stop/program No. selectable)
		RUN:	Program run
	HOLD:	Program hold	
	FAST:	Program fast-forward	
END:	Program end		
READY FAST:	Ready to run and fast-forward program		
AUTO:	Automatic operation		
MANUAL:	Manual operation (output can be controlled on console)		
Constant-value operation modes	READY:	Ready to run program (control stop)	
	RUN:	Program run	
	AUTO:	Automatic operation	
	MANUAL:	Manual operation (output can be controlled on console)	
Controller	PID controls	Proportional band (P)	0.0 to 1000.0% (0.0: ON-OFF control)
		Reset time (I)	0 to 3600 seconds. 0 seconds: PD control
		Rate time (D)	0 to 1200 seconds. 0 seconds: PI control
		MV limit	Lower limit: -5.0 to upper limit % Upper limit: Lower limit to +105.0%
		Manual reset	0.0 to 100.0%

Controller	PID controls	Number of PID sets	16 sets for program operation (9 segment unique sets + 7 sets for automatic zone selection)	
		PID set selection	Segment designation/automatic zone selection can be switched by program operation.	
		MV change	0.1 to 110.0%/0.1 seconds	
		Auto-tuning	Automatic setting of PID value by limit cycle system	
		ON-OFF control differential	0 to 1000 U	
	Direct/reverse action switching	Possible		
Programmer function	Switching	MV output switchable to SP output		
	Scaling	Possible		
	Output resolution	1/10000		
Outputs	Auxiliary output	Output types	PV, SP, deviation, MV, PV1, PV2	
		Scaling	Possible	
	Current output (5G) auxiliary outputs CH1, CH2	Output current: 4 to 20 mA dc Allowable load resistance: 600 Ω max. (under operating conditions) Output accuracy: ±0.1%FS max. (under standard conditions) Output resolution: 1/10000 Max. output current: 21.6 mA dc Min. output current: 2.4 mA dc Output updating cycle: 0.1 seconds Open terminal voltage: 25 V max.		
	Voltage output (6D)	Allowable load resistance: 600 Ω max. (under operating conditions) Load current adjustment: 2 to 22 mA variable Variable open terminal voltage: 25 V max. OFF leakage current: 100 µA max. Output response time: At ON-OFF 600 Ω load: 0.5 ms max. At OFF-ON 600 Ω load: 0.5 ms max. Output resolution: 1/1000 Time-proportional cycle: 1 to 240 seconds variable		
	Open-collector output (8D)	External supply voltage: 12 to 24V dc Max. load current: 100 mA/load OFF leakage current: 0.1 mA max. ON residual voltage: 2 V max. Output resolution: 1/1000 Time-proportional cycle: 1 to 240 seconds variable		
Event outputs	Open-collector output	External supply voltage: 12 to 24V dc Max. load current: 70 mA/load Max. common current: 500 mA OFF leakage current: 0.1 mA max. ON residual voltage: 2 V max.		
	Event types	PV type	PV, deviation, w/ deviation standby, absolute value deviation, w/ absolute value deviation standby, PV rate-of-change, SP, MV, G.Soak absolute value deviation, w/ G.Soak absolute value deviation standby, PV1 constant operation, PV2 constant operation, difference between PV1-PV2 at channel switching, difference between PV1-PV2	
		Time type	Time events, RAMP-E time monitor, segment time, program time	
		Code type	Code event, code event w/ timer, program No. binary code, segment No. binary code, program No. BCD code, segment No. BCD code	
		Mode type	Unique segment, RUN+HOLD+END+FAST, HOLD, READY+READY FAST, END, G.Soak standby, MANUAL, AT executing, FAST+READY FAST, console operation in progress, RUN, advance, all alarms, PV range alarm, controller alarm, PV1 currently selected, PV2 currently selected, low battery voltage	
	Event hysteresis	In case of PV type set, 0 to 1000 U		
Event ON delay	0.0 to 3000.0 can be set to four events			
Communications	RS-485	Network	Multidrop This controller is provided with only slave instrument functionality except when connected to ST221 (dedicated display device). 1 to 16 units max. (DIM) 1 to 31 units max. (CMA, SCM)	
		Data flow	Half duplex	
		Synchronization	Start-stop synchronization	
		Transmission system	Balanced (differential)	
		Data line	Bit serial	
	Signal line	5 transmit/receive lines (3-wire connection also possible)		

Communications	RS-485	Transmission speed	1200, 2400, 4800, 9600 bps	
		Transmission distance	500 m max. (total) (300 m max. for MA500 DIM connection)	
		Other	Conforming to RS-485 interface specifications	
		Char. bit count	11 bits/character	
		Format	1 start bit, even parity, 1 stop bit; or 1 start bit, no parity, and 2 stop bits	
		Data length	8 bits	
		Isolation	All inputs and outputs are completely isolated except external switch inputs.	
	RS-485 communications can be performed by connecting to a computer equipped with an RS-485 interface or to Yamatake Corporation MX200, MA500 (DK link II DIM) or CMA50 controllers.			
	RS-232C	Network	1: 1 Connected, This controller is provided with only slave instrument functionality.	
		Data flow	Half duplex	
		Synchronization	Start-stop synchronization	
		Transmission system	Unbalanced type	
		Data line	Bit serial	
Signal line		3 transmit/receive lines		
Transmission speed		1200, 2400, 4800, 9600 bps		
Transmission distance		15 m max.		
Other		Conforming to RS-232C interface specifications		
Char. bit count		11 bits/character		
Format		1 start bit, even parity, 1 stop bit; or 1 start bit, no parity, and 2 stop bits		
Data length		8 bits		
Isolation	All inputs and outputs are completely isolated except external switch inputs.			
General specifications	Memory backup	Memory	Battery backed up RAM	
		Battery life	Controller power OFF: Approx. 5 years under standard conditions Controller power ON: Approx. 10 years under standard conditions	
	Rated power voltage	100 to 240V ac, 50/60 Hz		
	Power consumption	40 VA max.		
	Power ON rush current	50 A max.		
	Power ON operation	Reset time: 10 seconds max. (time until normal operation is possible under normal operating conditions)		
	Allowable transient power loss	20 ms max. (under operating conditions)		
	Insulation resistance	Min. 50 MΩ across power terminal ③⑨ or ④⑩ and FG terminal ⑤⑪ or ⑥⑫ (by 500V dc megger)		
	Dielectric strength	1500V ac 50/60 Hz for 1 minute between power terminal and FG terminal Note) The primary side and secondary side capacities are joined inside the product. For this reason, when carrying out a withstand voltage test, disconnect the wiring of the grounded secondary side terminals (e.g. when grounding type thermocouple is used) from that terminal. If the test is carried out with the wiring as it is, this might result in malfunction.		
	Standard conditions	Ambient temperature	23±2°C	
		Ambient humidity	60±5%RH	
		Rated power voltage	105V ac±1%	
		Power frequency	50±1 Hz, or 60±1 Hz	
		Vibration resistance	0 m/s ²	
		Shock resistance	0 m/s ²	
		Mounting angle	Reference plane (vertical) ±3°	
	Operating conditions	Ambient temperature range	0 to 50°C (ambient temperature at the bottom side of case when gang-mounted)	
		Ambient humidity range	10 to 90%RH (condensation not allowed)	
		Rated power voltage	100 to 240V ac	
		Allowable power voltage	90 to 264V ac	
Power frequency		50±2 Hz, or 60±2 Hz		
Vibration resistance		0 to 1.96 m/s ²		
Shock resistance		0 to 9.80 m/s ²		
Mounting angle	Reference plane (vertical) ±10°			

General specifications	Transport/storage conditions	Ambient temperature range	-20 to +70°C				
		Ambient humidity range	10 to 95%RH (condensation not allowed)				
		Vibration resistance	0 to 4.90 m/s ² (10 to 60 Hz for 2 hours each in X, Y and Z directions)				
		Shock resistance	0 to 490 m/s ² (3 times vertically)				
		Package drop test	Drop height: 60 cm (1 angle, 3 edges and 6 planes; free fall)				
	Terminal screw	M3.5 self-tapping screws					
	Terminal screw tightening torque	0.78 to 0.98 N•m					
	Mask/case materials	Mask: Multilon		Case: Multilon			
Mask/case color	Mask: Dark gray (Munsell 5Y3.5/1) Case: Light gray (Munsell 2.5Y7.5/1)						
Installation	Specially designed mounting bracket						
Weight	1.5 kg						
Standard accessories	Item	Model No.	Q'ty	Auxiliary parts (sold separately)	Item	Model No.	Q'ty
	Unit indicating label	—	1		Soft dust-proof cover set	81446141-001	—
	Mounting bracket	81446044-001	1 set (2 p'ces)		Lithium battery set	81446140-001	Approx. 200 g
	User's Manual	CP-UM-5005E	1				
	Terminal cover	81446176-001	1				

Input Types and Ranges (selectable in setup)

● Thermocouple

Input Type			Input Range (FS)		Accuracy (under standard conditions)	
Symbol	Code	Range No.	°C	°F		
K (CA)	K46	16	-200.0 to +200.0	-300.0 to +400.0	±0.1%FS	
K (CA)	K09	0	0.0 to 1200.0	0 to 2400	±0.1%FS	
K (CA)	K08	1	0.0 to 800.0	0 to 1600	±0.1%FS	
K (CA)	K04	2	0.0 to 400.0	0 to 750	±0.1%FS	
E (CRC)	E08	3	0.0 to 800.0	0 to 1800	±0.1%FS	
J (IC)	J08	4	0.0 to 800.0	0.0 to 1600	±0.1%FS	
T (CC)	T44	5	-200.0 to +300.0	-300 to +700	±0.1%FS	±0.3%FS between -200°C to -45°C
B (PR30-6)	B18	6	0.0 to 1800.0	0 to 3300	±0.1%FS	±4.0%FS between 0 to 260°C, ±0.15%FS between 260 to 800°C
R (PR13)	R16	7	0.0 to 1600.0	0 to 3100	±0.1%FS	
S (PR10)	S16	8	0.0 to 1600.0	0 to 3100	±0.1%FS	
W (WRe5-26)	W23	9	0.0 to 2300.0	0 to 4200	±0.1%FS	
W (WRe5-26)	W14	10	0.0 to 1400.0	0 to 2552	±0.1%FS	
PR40-20	D19	11	0.0 to 1900.0	0 to 3400	±0.2%FS	±0.9%FS between 0 to 300°C, ±0.5%FS between 300 to 800°C
N	U13	12	0.0 to 1300.0	32 to 2372	±0.1%FS	
PLII	Y13	13	0.0 to 1300.0	32 to 2372	±0.1%FS	
Ni-Ni-Mo	Z13	14	0.0 to 1300.0	32 to 2372	±0.1%FS	
Golden iron chromel	Z06	15	0.0 to 300.0 K (K: Kelvin)		±0.4%FS	

● Resistance temperature detector (RTD)

Input Type			Input Range (FS)		Accuracy (under standard conditions)	
Symbol	Code	Range No.	°C	°F		
JIS'89Pt100 (IEC Pt100 Ω)	F50	64	-200.0 to +500.0	-300.0 to +900.0	±0.1%FS	
	F46	65	-200.0 to +200.0	-300.0 to +400.0	±0.1%FS	
	F32	66	-100.0 to +150.0	-150.0 to +300.0	±0.1%FS	
	F36	67	-50.0 to +200.0	-50.0 to +400.0	±0.1%FS	
	F33	68	-40.0 to +60.0	-40.0 to +140.0	±0.15%FS	
	F01	69	0.0 to 100.0	0.0 to 200.0	±0.15%FS	
	F03	70	0.0 to 300.0	0.0 to 500.0	±0.1%FS	
	F05	71	0.0 to 500.0	0.0 to 900.0	±0.1%FS	
JIS'89JPt100	P50	96	-200.0 to +500.0	-300.0 to +900.0	±0.1%FS	
	P46	97	-200.0 to +200.0	-300.0 to +400.0	±0.1%FS	
	P32	98	-100.0 to +150.0	-150.0 to +300.0	±0.1%FS	
	P36	99	-50.0 to +200.0	-50.0 to +400.0	±0.1%FS	
	P33	100	-40.0 to +60.0	-40.0 to +140.0	±0.15%FS	
	P01	101	0.0 to 100.0	0.0 to 200.0	±0.15%FS	
	P03	102	0.0 to 300.0	0.0 to 500.0	±0.1%FS	
	P05	103	0.0 to 500.0	0.0 to 900.0	±0.1%FS	

- Thermocouple : K,E,J,T,B,R,S (JIS C 1602-1981)
WRe5-26 (Hoskins Data)
PR40-20 (Johnson Matthey Data)
N (N.B.S. Monograph 161)
PLII (Engelhard Industries Data (IPTS68))
Ni-NiMo (General Electric Data)
Gold iron chromel (Hayashidenko Data)

Resistance temperature detector (RTD):
Pt100, JPt100 (JIS C 1604-1989)

● DC current, DC voltage

Input Type			Input Range (FS)		Accuracy (under standard conditions)	
Symbol	Code	Range No.				
mA (linear)	C01	48	4 to 20 mA	Programmable range -19999 to +20000 (decimal point position can be changed)	±0.1%FS	
	Z51	52	2.4 to 20 mA		±0.1%FS	
mV	M01	49	0 to 10 mV		±0.1%FS	
	L02	50	-10 to +10 mV		±0.1%FS	
		51	0 to 100 mV		±0.15%FS	
mA (linear)	C01	128	4 to 20 mA		Programmable range -19999 to +20000 (decimal point position can be changed)	±0.15%FS
	Z51	134	2.4 to 20 mA	±0.1%FS		
V (linear)		129	0 to 1 V	±0.1%FS		
		130	-1 to +1 V	±0.1%FS		
	V01	131	1 to 5 V	±0.1%FS		
		132	0 to 5 V	±0.1%FS		
		133	0 to 10 V	±0.1%FS		

! Handling Precautions

- The unit of code Z06 is Kelvin (K).
- The PV lower limit alarm does not occur with codes F50 and P50.
- The number of digits past the decimal point for DC current and DC voltage is programmable within the range 0 to 4.

MODEL SELECTION GUIDE

I II III IV V VI Example: DCP551B10100

I	II	III	IV	V	VI	Specifications	
Basic Model No.	—	Number of PV inputs	Appended No.	Option	Additions		
DCP551	B					Digital Programmable Controller (single-loop model)	
		1				Mark II	
		2				PV input CH1	
			0				PV input CH2
				0			0 (fixed)
				0			None
				1			Auxiliary output CH1
				2			Auxiliary output CH2, communications
					00		None
					D0		Inspection Certificate
				Y0		Complying with the traceability certification	

EXTERNAL DIMENSIONS

PANEL CUTOUT

(Unit: mm)

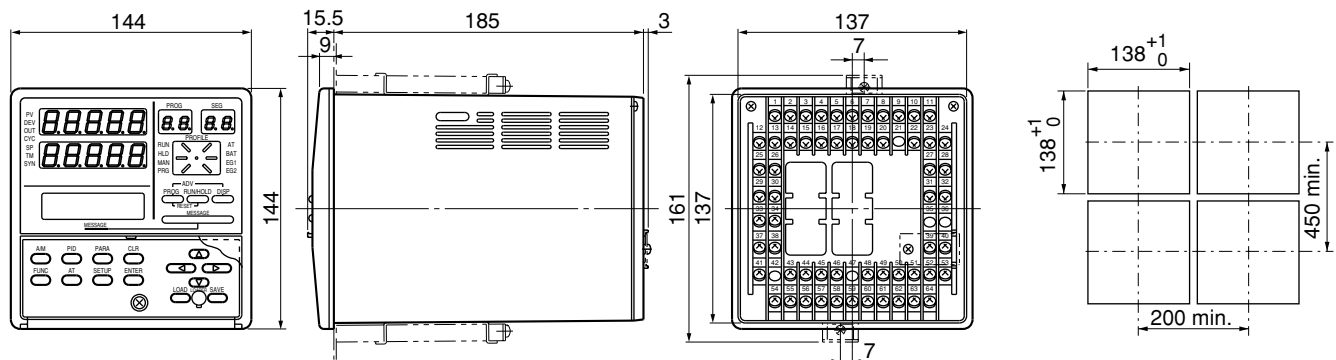

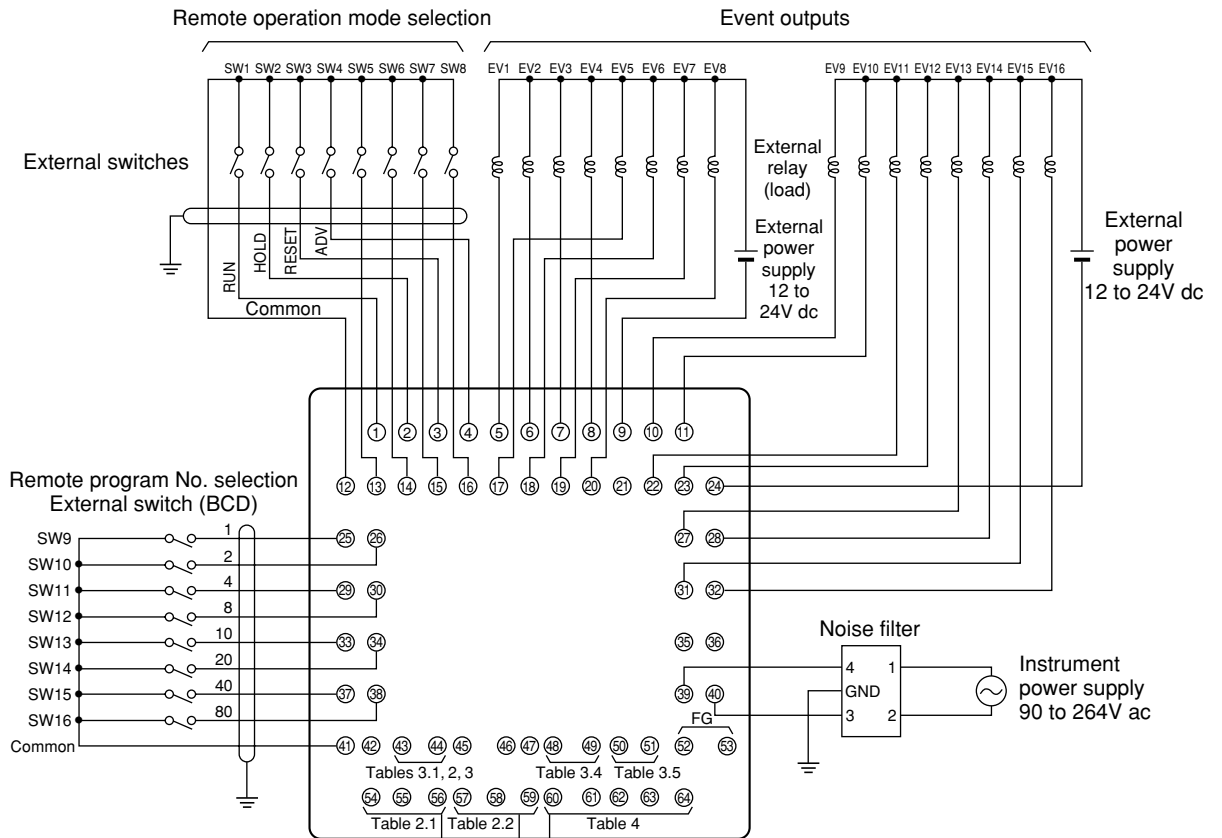

Table 2 PV input

1. ch 1			
Thermocouple	Resistance temperature detector (RTD)	Voltage (mV/V)	Current (mA)
2. ch 2			
Thermocouple	Resistance temperature detector (RTD)	Voltage (mV/V)	Current (mA)

Table 3 Control, Setup and Auxiliary Output

1. Transistor Open Collector	2. Voltage	3. Current
Control output	Control output	Control output/ Setup output
4. Current	5. Current	
Auxiliary output CH1	Auxiliary output CH2	

Continued on following page

Table 4 Communications I/O

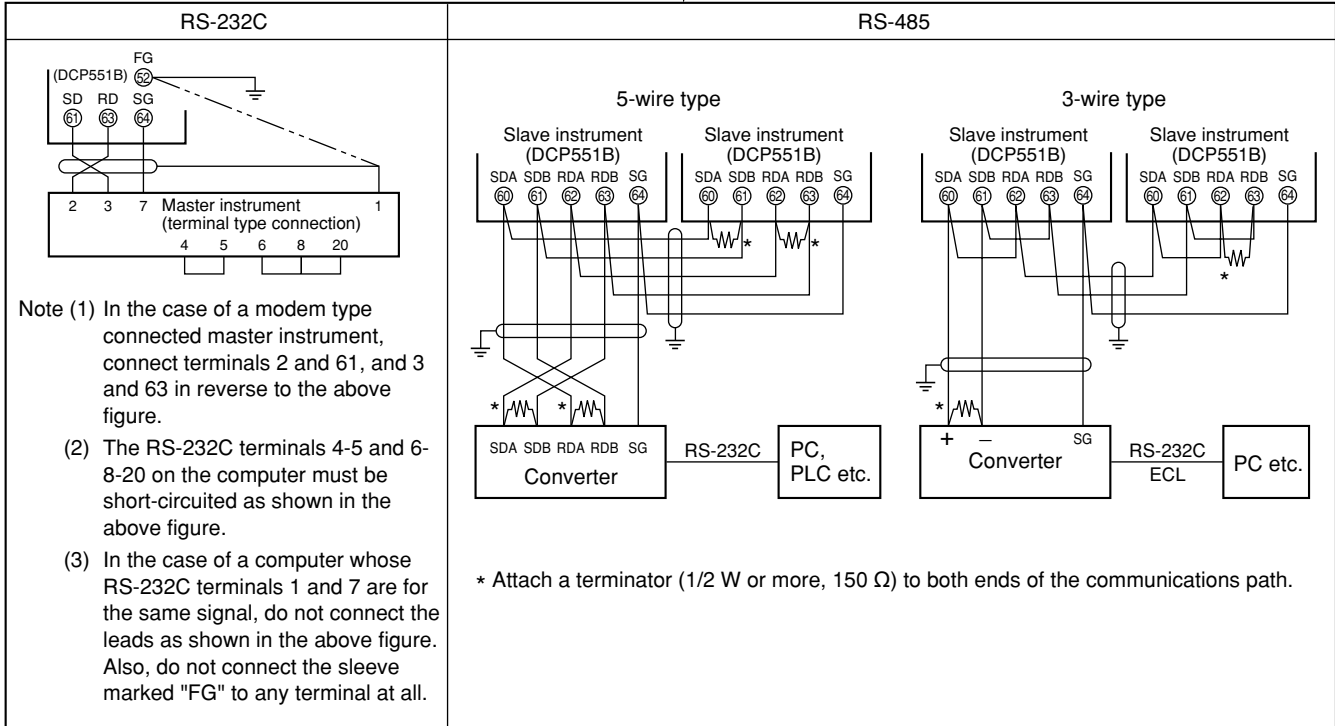

WIRING PRECAUTIONS

1. Isolating Inputs and Outputs inside the Controller

Solid lines — show isolated items.
Dotted lines - - - - show non-isolated items.

PV input CH1	Digital circuit	Control output
PV input CH2		Auxiliary output CH1
Loader communications		Auxiliary output CH2
External switch input		Event output
Communications		

2. Noise Countermeasures for Instrument Power Supplies

(1) Reducing noise

Connect the DCP551B to a single-phase power supply for instruments, and take measures to prevent the influence of electrical noise.

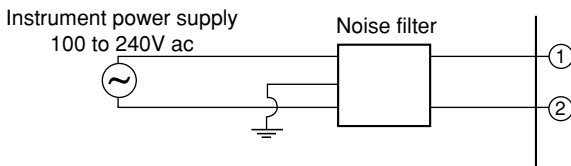

(2) When there is a lot of noise

If there is a lot of electrical noise, we recommend inserting an insulating transformer in the power circuit and using a line filter.

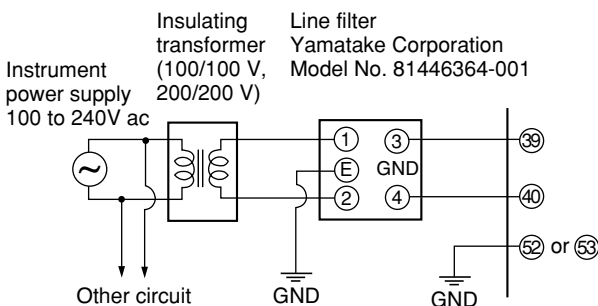

3. Noise Generating Sources and Countermeasures

Generally, the following generate electrical noise:

Relays and contacts, electromagnetic coils, solenoid valves, power lines (in particular, 90V ac min.), induction loads, inverters, motor commutators, phase angle control SCR, radio communications equipment, welding equipment, high-voltage ignition equipment

(1) Fast-rising noise

CR filters are effective in countering fast-rising noise.

Recommended CR filter:
Yamatake Corporation Model No.
81446365-001

(2) Noise with a high wave height

Varistors are effective in countering noise with a high wave height. However, note that the varistor may become short-circuited when trouble occurs. Pay attention to this when providing a varistor on a controller.

Recommended varistor:
Yamatake Corporation Model No.
81446366-001 (for 100V ac)
81446367-001 (for 200V ac)

4. Ground

Use only the FG terminal 52 or 53 on the DCP551B for grounding. Do not ground across other terminals. When it is difficult to ground shielded cable, prepare a separate GND terminal plate (earth bar).

Ground type: 100 Ω max.
Ground cable: 2 mm² min. annealed-copper wire (AWG14)
Cable length: Max. 20 m

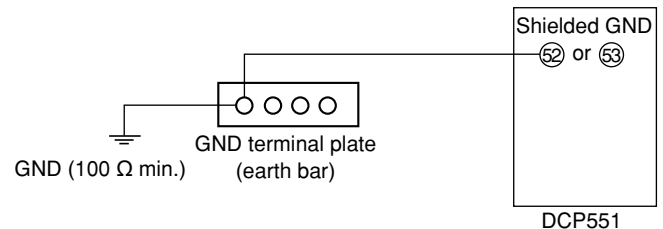

5. Precautions during Wiring

- (1) **After providing anti-noise measures**, do not bundle primary and secondary power leads together, or pass them through the same piping or wiring duct.
- (2) Maintain a distance of at least 50 cm between **I/O signal leads or communications leads and the power lead**. Also, do not pass these leads through the same piping or wiring duct.

6. Inspection after Wiring

After wiring is completed, be sure to inspect and check the wiring state. Wrong wiring may cause controller malfunction or accidents.



RESTRICTIONS ON USE

This product has been designed, developed and manufactured for general-purpose application in machinery and equipment. Accordingly, when used in the applications outlined below, special care should be taken to implement a fail-safe and/or redundant design concept as well as a periodic maintenance program.

- **Safety devices for plant worker protection**
- **Start/stop control devices for transportation and material handling machines**
- **Aeronautical/aerospace machines**
- **Control devices for nuclear reactors**

Never use this product in applications where human safety may be put at risk.

DIGITRONIK is a trademark of Yamatake Corporation.

Specifications are subject to change without notice.

azbil

Yamatake Corporation Advanced Automation Company

1-12-2 Kawana, Fujisawa
Kanagawa 251-8522 Japan
URL: <http://www.azbil.com>

(H)
1st Edition: Issued in May, 2008

No part of this publication may be reproduced or duplicated without the prior written permission of Yamatake Corporation.