

DigitroniK Programmable Controller DCP551 Mark II

The DigitroniK DCP551 Mark II is a high-function programmable controller supporting up to 99 program patterns to which thermocouple, resistance temperature detector (RTD), DC voltage, DC current and other signals can be input.

The DCP551 Mark II supports a memory card interface, 16 event outputs, 16 external switch inputs and a wide range of other functions as part of the standard specification; and communications and auxiliary output as option functions.



FEATURES

- Accuracy of $\pm 0.1\%FS$. Easy-to-view large display characters. Compact design
- 2 PV input type also available
- Any input type can be selected by console key operation.
- Easy operation aided by guidance messages
- Up to 99 program patterns can be stored and up to 99 segments can be programmed to each pattern.
- Program patterns can be saved or loaded using the memory card SKM series (sold separately).
- The memory card SKM series is durable and non-contact.
- Various events can be selected and set for the 16 event outputs, and code events comprising a combination of two or more points can be set.
- 16 external switch inputs allow the control of remote selection of program Nos. or operation.
- Can be connected to dedicated display device ST221 to display patterns, trends and progress of programs.
- CE marking-compatible

Applicable standards: EN61010-1, EN50081-2, EN50082-2

BASIC FUNCTION BLOCKS of DCP551 Mark II

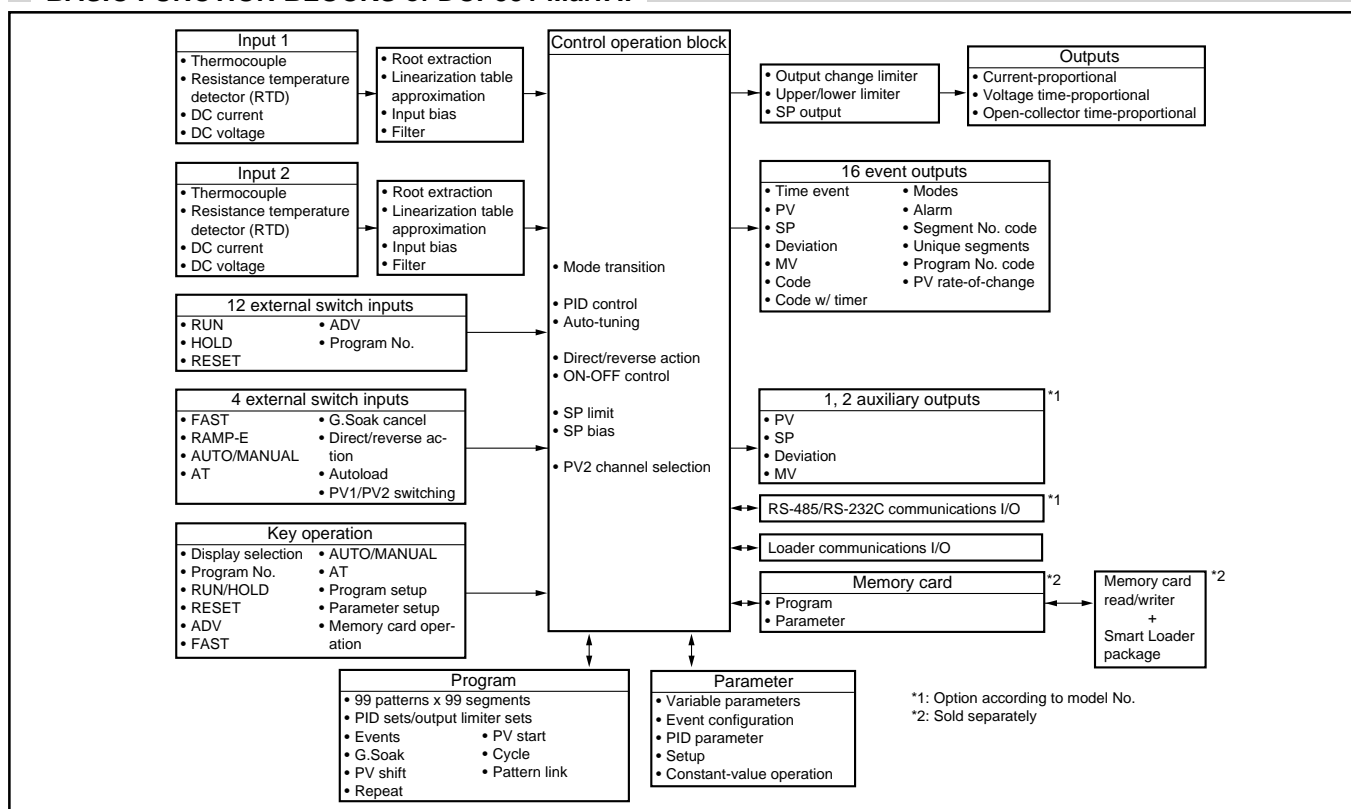

SPECIFICATIONS

Program	Number of programs	99
	Number of segments	99 per program, 2000 per controller
	Segment setting system	RAMP-X: Set by set points (SP) and time. RAMP-T: Set by set points (SP) and ramp (θ) RAMP-E: Set by set points (SP) and Δ SP per external switch input 1 pulse
	Segment time	0 to 500 hours 0 minute, 0 to 500 minutes 0 second, 0.0 to 3000.0 seconds (time unit selectable)
	Segment ramp	1 to 10000 U/hour, 1 to 10000 U/minute, 1 to 10000 U/second (time unit selectable)
	Segment ΔSP	1 to 10000 U/1 pulse
	Number of sub-functions	4000 settings per controller
	Sub-function action	Events, PID set, output limiter set, G.Soak, PV shift, repeat
	Events (16)	Set operating point corresponding to event type
	PID set No.	Set 0 (continuation of previous segment), 1 to 9, A set (automatically switched) and ON-OFF control
	Output limiter set	Set 0 (continuation of previous segment), 1 to 9
	G.Soak	Set type (start/end points and overall) and G.Soak width 0 to 1000 U.
	PV shift	-10000 to +10000 U
	Repeat	Set return destination segment No. and repeat count.
	PV start	Set type (rising/falling or both) for each program.
	Cycle	Set cycle count for each program.
	Pattern link	Set program No.0 to 99 (0: no link) for each program.
	Tag	Set 8 alphanumeric or symbols for each program.
	Basic time accuracy	$\pm 0.01\%$ (segment time setting = 0, with 0.1 second delay for each repeat and cycle)
Inputs	Input type	Thermocouple, resistance temperature detector (RTD), DC voltage, DC current multi-range (See pages 6, 7.)
	Sampling cycle	0.1 seconds
	Input bias current	Thermocouple, DC voltage input: Max. $\pm 1.3 \mu\text{A}$ (at peak value and reference conditions) 1 V or higher range: Max. $-3 \mu\text{A}$
	Input impedance	DC current input: approx. 50Ω (under operating conditions)
	Measuring current	RTD input: Approx. 1 mA current flow from terminal A (under operating conditions)
	Influence of wiring resistance	Thermocouple, DC voltage input: Thermocouple: $0.5 \mu\text{V}/\Omega$ DC voltage (max. 1 V range): $0.5 \mu\text{V}/\Omega$ DC voltage (5 V range): $3 \mu\text{V}/\Omega$ DC voltage (10 V range): $6 \mu\text{V}/\Omega$ RTD input: Max. $\pm 0.01\% \text{FS}/\Omega$ in wiring resistance range 0 to 10Ω Range of F01, F33, P01 and P33: $\pm 0.02\% \text{FS}/\Omega$ max.
	RTD input allowable wiring resistance	<ul style="list-style-type: none"> Ranges other than F01, F33, P01 and P33: 85Ω max. (including Zener barrier resistance. Note that site adjustment is required.) Ranges of F01, F33, P01 and P33: 10Ω max. (Zener barrier cannot be used.)
	Allowable parallel resistance	Thermocouple disconnection detection allowable parallel resistance: $1 \text{ M}\Omega$ min.
	Max. allowable input	Thermocouple, DC voltage input: -5 to $+15\text{V}$ dc DC current input: 50 mA dc, 2.5V dc
	Burnout	Detection selectable
	Over-range detection threshold	$110\% \text{FS}$ min.: Upscaled $-10\% \text{FS}$ max.: Downscaled (Note that F50 range is not downscaled.)
	Cold-junction compensation accuracy	$\pm 0.5^\circ\text{C}$ (under standard conditions)
	Cold- junction compensation system	Internal/external (0°C only) compensation selectable
	Scaling	-19999 to $+20000 \text{ U}$ (possible in case of linear input only. Inverse scaling possible. Decimal point position settable at any point)
	Square root extraction	Possible. Dropout: 0.2 to 10.0% in case of DC current or DC voltage range
	PV equalizer (linearization table approximation)	PV1: 9 segments (10 points set) PV2: 19 segments (20 points set)
	Input bias	-1000 to $+1000 \text{ U}$ variable
	Digital filter	0.0 to 120.0 seconds variable (0.0: filter OFF)

External switch inputs	Number of inputs	16	
	Types of connectable outputs	Dry contacts (relay contact) and open-collector (current sink to ground)	
	Terminal voltage (open)	8.5 V±0.5 V between common terminals (terminals ⑫, ⑩) and each input terminal (under operating conditions)	
	Terminal current (short-circuit)	Approx. 6 mA between each terminal (under operating conditions)	
	Allowable contact resistance (dry contact)	ON: 250 Ω max. (under operating conditions) OFF: 100 kΩ min. (under operating conditions)	
	Voltage drop (at open-collector ON)	2 V max. (under operating conditions)	
	Leakage current (at open-collector OFF)	0.1 mA max. (under operating conditions)	
	Parallel connection with other instruments	Can be connected to Yamatake Corporation SDC40 and SDC10 series	
	Assignments (fixed)	RUN, HOLD, RESET, ADV, program No.	
	Assignments (variable)	RAMP-E, FAST, AT, AUTO/MANUAL, G.Soak cancel, direct/reverse action, auto-load, PV1/2 switching	
	Input sampling cycle	0.1 seconds	
	ON detection min. hold time	0.2 seconds (0.4 seconds for program No.)	
	Indication/programmer	Upper display	Green 5-digit, 7-segment LED This displays PV values in the basic display state. Item codes are displayed in the parameter setup.
Lower display		Orange 5-digit, 7-segment LED This displays SP and output % in the basic display state. Setting values are displayed in the parameter setup.	
Program No. display		Green 2-digit, 7-segment LED This displays program No. in the basic display state.	
Segment No. display		Green 2-digit, 7-segment LED This displays segment No. in the basic display state. Item Nos. are displayed in parameter setup, and alarm No. is displayed when alarm occurs.	
Message display		This displays output graph, deviation graph, event state and tags in the basic display state. This displays reference messages in the parameter setup and program setup. This displays operation details and operation results of memory card operation.	
Profile display		7 orange LEDs Displays program pattern rise, soak and fall trends.	
Status displays		22 round LEDs Modes: RUN, HLD, MAN, PRG (green) Display details: PV, SP, OUT, TM, CYC, SYN, DEV (green) Battery voltage: BAT (red) (blinks at low voltage) Status: AT (green) Events: EG1, EG2 (red)	
Operation keys		18 rubber keys	
Loader connector port		1 (dedicated cable with stereo miniplugs)	
Modes		Program operation modes	READY:
	RUN:		Program run
	Constant-value operation modes	READY:	Ready to run program (control stop)
		RUN:	Program run
Controller	PID controls	Proportional band (P)	0.0 to 1000.0% (0.0: ON-OFF control)
		Reset time (I)	0 to 3600 seconds. 0 seconds: PD control
		Rate time (D)	0 to 1200 seconds. 0 seconds: PI control
		MV limit	Lower limit: -5.0 to upper limit % Upper limit: Lower limit to +105.0%
		Manual reset	0.0 to 100.0%

Controller	PID controls	Number of PID sets	16 sets for program operation (9 segment unique sets + 7 sets for automatic zone selection)	
		PID set selection	Segment designation/automatic zone selection can be switched by program operation.	
		MV change	0.1 to 110.0%/0.1 seconds	
		Auto-tuning	Automatic setting of PID value by limit cycle system	
		ON-OFF control differential	0 to 1000 U	
	Direct/reverse action switching	Possible		
Programmer function	Switching	MV output switchable to SP output		
	Scaling	Possible		
	Output resolution	1/10000		
Outputs	Auxiliary output	Output types	PV, SP, deviation, MV, PV1, PV2	
		Scaling	Possible	
	Current output (5G) auxiliary outputs CH1, CH2	Output current:	4 to 20 mA dc	
		Allowable load resistance:	600 Ω max. (under operating conditions)	
		Output accuracy:	$\pm 0.1\%$ FS max. (under standard conditions)	
		Output resolution:	1/10000	
Max. output current:		21.6 mA dc		
Min. output current:	2.4 mA dc			
Output updating cycle:	0.1 seconds			
Open terminal voltage:	25 V max.			
Voltage output (6D)	Allowable load resistance:	600 Ω max. (under operating conditions)		
	Load current adjustment:	2 to 22 mA variable		
	Variable open terminal voltage:	25 V max.		
	OFF leakage current:	100 μ A max.		
	Output response time:	At ON-OFF 600 Ω load: 0.5 ms max. At OFF-ON 600 Ω load: 0.5 ms max.		
Output resolution:	1/1000			
Time-proportional cycle:	1 to 240 seconds variable			
Open-collector output (8D)	External supply voltage:	12 to 24V dc		
	Max. load current:	100 mA/load		
	OFF leakage current:	0.1 mA max.		
	ON residual voltage:	2 V max.		
	Output resolution:	1/1000		
Time-proportional cycle:	1 to 240 seconds variable			
Event outputs	Open-collector output	External supply voltage:	12 to 24V dc	
		Max. load current:	70 mA/load	
		Max. common current:	500 mA	
		OFF leakage current:	0.1 mA max.	
		ON residual voltage:	2 V max.	
	Event types	PV type	PV, deviation, w/ deviation standby, absolute value deviation, w/ absolute value deviation standby, PV rate-of-change, SP, MV, G.Soak absolute value deviation, w/ G.Soak absolute value deviation standby, PV1 constant operation, PV2 constant operation, difference between PV1-PV2 at channel switching, difference between PV1-PV2	
Time type		Time events, RAMP-E time monitor, segment time, program time		
Code type		Code event, code event w/ timer, program No. binary code, segment No. binary code, program No. BCD code, segment No. BCD code		
Mode type		Unique segment, RUN+HOLD+END+FAST, HOLD, READY+READY FAST, END, G.Soak standby, MANUAL, AT executing, FAST+READY FAST, console operation in progress, RUN, advance, all alarms, PV range alarm, controller alarm, PV1 currently selected, PV2 currently selected, low battery voltage		
Event hysteresis	In case of PV type set, 0 to 1000 U			
Event ON delay	0.0 to 3000.0 can be set to four events			
Communications	RS-485	Network	Multidrop This controller is provided with only slave instrument functionality except when connected to ST221 (dedicated display device). 1 to 16 units max. (DIM) 1 to 31 units max. (CMA, SCM)	
		Data flow	Half duplex	
		Synchronization	Start-stop synchronization	
		Transmission system	Balanced (differential)	
		Data line	Bit serial	
		Signal line	5 transmit/receive lines (3-wire connection also possible)	

Communications	RS-485	Transmission speed	1200, 2400, 4800, 9600 bps				
		Transmission distance	500 m max. (total) (300 m max. for MA500 DIM connection)				
		Other	Conforming to RS-485 interface specifications				
		Char. bit count	11 bits/character				
		Format	1 start bit, even parity, 1 stop bit; or 1 start bit, no parity, and 2 stop bits				
		Data length	8 bits				
		Isolation	All inputs and outputs are completely isolated except external switch inputs.				
	RS-485 communications can be performed by connecting to a computer equipped with an RS-485 interface or to Yamatake Corporation MX200, MA500 (DK link II DIM) or CMA50 controllers.						
		RS-232C	Network	1: 1 Connected, This controller is provided with only slave instrument functionality.			
			Data flow	Half duplex			
			Synchronization	Start-stop synchronization			
			Transmission system	Unbalanced type			
			Data line	Bit serial			
			Signal line	3 transmit/receive lines			
Transmission speed			1200, 2400, 4800, 9600 bps				
Transmission distance			15 m max.				
Other			Conforming to RS-232C interface specifications				
Char. bit count			11 bits/character				
Format			1 start bit, even parity, 1 stop bit; or 1 start bit, no parity, and 2 stop bits				
Data length			8 bits				
Isolation			All inputs and outputs are completely isolated except external switch inputs.				
Memory card	Program, PID, various parameters (SETUP, PARA, event) and other data can be saved and loaded to and from memory card (sold separately).						
	Save (SAVE)	Function for copying DCP551 data to memory card.					
	Load (LOAD)	Function for copying memory card data to DCP551.					
	Memory card (sold separately)						
	Model No.	Memory Type	Size (bytes)	Number of Programs	Battery Replacement	Parameters	
	SKM008A	RAM	7.00 K	Max. 20	Not possible	Setup data	
	SKM016A	RAM	14.50 K	Max. 52	Not possible	Variable parameters	
	SKM064A	RAM	61.75 K	Max. 99	Not possible	PID parameters	
	SKM256C	RAM	251 K	Max. 99	Possible	Event configuration data	
	SKM008E	EEPROM	7.00 K	Max. 20	Battery not required	Constant-value operation data	
	SKM032E	EEPROM	29.75 K	Max. 99	Battery not required	data	
<ul style="list-style-type: none"> Number of bytes per program is 26 + (5 x number of segments) + (5 x number of sub-functions). Number of bytes per parameter <ul style="list-style-type: none"> Setup data: 217 bytes (17 + 2 x 100) Variable parameters: 257 bytes (17 + 2 x 120) PID parameters + constant-value operation data: 291 bytes (17+ 2 x 8 x 16 + 2 x 9) Event configuration data: 209 bytes (17 + 2 x 3 x 32) 							
General specifications	Memory backup	Memory Battery life	Battery backed up RAM Controller power OFF: Approx. 5 years under standard conditions Controller power ON: Approx. 10 years under standard conditions				
	Rated power voltage	100 to 240V ac, 50/60 Hz					
	Power consumption	25 VA max.					
	Power ON rush current	50 A max.					
	Power ON operation	Reset time: 10 seconds max. (time until normal operation is possible under normal operating conditions)					
	Allowable transient power loss	20 ms max. (under operating conditions)					
	Insulation resistance	Min. 50 MΩ across power terminal ③⑨ or ④⑩ and FG terminal ⑤⑪ or ⑥⑫ (by 500V dc megger)					
	Dielectric strength	1500V ac 50/60 Hz for 1 minute between power terminal and FG terminal Note) The primary side and secondary side capacities are joined inside the product. For this reason, when carrying out a withstand voltage test, disconnect the wiring of the grounded secondary side terminals (e.g. when grounding type thermocouple is used) from that terminal. If the test is carried out with the wiring as it is, this might result in malfunction.					

General specifications	Standard conditions	Ambient temperature	23±2°C				
		Ambient humidity	60±5%RH				
		Rated power voltage	105V ac±1%				
		Power frequency	50±1 Hz, or 60±1 Hz				
		Vibration resistance	0 m/s ²				
		Shock resistance	0 m/s ²				
		Mounting angle	Reference plane (vertical) ±3°				
	Operating conditions	Ambient temperature range	0 to 50°C (ambient temperature at the bottom side of case when gang-mounted)				
		Ambient humidity range	10 to 90%RH (condensation not allowed)				
		Rated power voltage	100 to 240V ac				
		Allowable power voltage	90 to 264V ac				
		Power frequency	50±2 Hz, or 60±2 Hz				
		Vibration resistance	0 to 1.96 m/s ²				
		Shock resistance	0 to 9.80 m/s ²				
	Transport/storage conditions	Ambient temperature range	-20 to +70°C				
		Ambient humidity range	10 to 95%RH (condensation not allowed)				
		Vibration resistance	0 to 4.90 m/s ² (10 to 60 Hz for 2 hours each in X, Y and Z directions)				
Shock resistance		0 to 490 m/s ² (3 times vertically)					
Package drop test		Drop height: 60 cm (1 angle, 3 edges and 6 planes; free fall)					
Terminal screw	M3.5 self-tapping screws						
Terminal screw tightening torque	0.78 to 0.98 N•m						
Mask/case materials	Mask: Multilon		Case: Multilon				
Mask/case color	Mask: Dark gray (Munsell 5Y3.5/1) Case: Light gray (Munsell 2.5Y7.5/1)						
Installation	Specially designed mounting bracket						
Weight	1.5 kg						
Standard accessories	Item	Model No.	Q'ty	Auxiliary parts (sold separately)	Item	Model No.	Q'ty
	Unit indicating label	—	1		Soft dust-proof cover set	81446141-001	—
	Mounting bracket	81446044-001	1 set (2 p'ces)		Lithium battery set	81446140-001	Approx. 200 g
	User's Manual	CP-UM-5005E	1		Memory card (RAM, battery replacement not possible)	SKM008A SKM016A SKM064A	Approx. 30 g
	Terminal cover	81446176-001	1		Memory card (RAM, battery replacement possible)	SKM256C	
					Memory card (EEPROM, battery not required)	SKM008E SKM032E	

Input Types and Ranges (selectable in setup)

● Thermocouple

Input Type			Input Range (FS)		Accuracy (under standard conditions)	
Symbol	Code	Range No.	°C	°F		
K (CA)	K46	16	-200.0 to +200.0	-300.0 to +400.0	±0.1%FS	
K (CA)	K09	0	0.0 to 1200.0	0 to 2400	±0.1%FS	
K (CA)	K08	1	0.0 to 800.0	0 to 1600	±0.1%FS	
K (CA)	K04	2	0.0 to 400.0	0 to 750	±0.1%FS	
E (CRC)	E08	3	0.0 to 800.0	0 to 1800	±0.1%FS	
J (IC)	J08	4	0.0 to 800.0	0.0 to 1600	±0.1%FS	
T (CC)	T44	5	-200.0 to +300.0	-300 to +700	±0.1%FS	±0.3%FS between -200°C to -45°C
B (PR30-6)	B18	6	0.0 to 1800.0	0 to 3300	±0.1%FS	±4.0%FS between 0 to 260°C, ±0.15%FS between 260 to 800°C
R (PR13)	R16	7	0.0 to 1600.0	0 to 3100	±0.1%FS	
S (PR10)	S16	8	0.0 to 1600.0	0 to 3100	±0.1%FS	
W (WRe5-26)	W23	9	0.0 to 2300.0	0 to 4200	±0.1%FS	
W (WRe5-26)	W14	10	0.0 to 1400.0	0 to 2552	±0.1%FS	
PR40-20	D19	11	0.0 to 1900.0	0 to 3400	±0.2%FS	±0.9%FS between 0 to 300°C, ±0.5%FS between 300 to 800°C
N	U13	12	0.0 to 1300.0	32 to 2372	±0.1%FS	
PLII	Y13	13	0.0 to 1300.0	32 to 2372	±0.1%FS	
Ni-Ni•Mo	Z13	14	0.0 to 1300.0	32 to 2372	±0.1%FS	
Golden iron chromel	Z06	15	0.0 to 300.0 K (K: Kelvin)		±0.4%FS	

● Resistance temperature detector (RTD)

Input Type			Input Range (FS)		Accuracy (under standard conditions)	
Symbol	Code	Range No.	°C	°F		
JIS'89Pt100 (IEC Pt100 Ω)	F50	64	-200.0 to +500.0	-300.0 to +900.0	±0.1%FS	
	F46	65	-200.0 to +200.0	-300.0 to +400.0	±0.1%FS	
	F32	66	-100.0 to +150.0	-150.0 to +300.0	±0.1%FS	
	F36	67	-50.0 to +200.0	-50.0 to +400.0	±0.1%FS	
	F33	68	-40.0 to +60.0	-40.0 to +140.0	±0.15%FS	
	F01	69	0.0 to 100.0	0.0 to 200.0	±0.15%FS	
	F03	70	0.0 to 300.0	0.0 to 500.0	±0.1%FS	
	F05	71	0.0 to 500.0	0.0 to 900.0	±0.1%FS	
JIS'89JPt100	P50	96	-200.0 to +500.0	-300.0 to +900.0	±0.1%FS	
	P46	97	-200.0 to +200.0	-300.0 to +400.0	±0.1%FS	
	P32	98	-100.0 to +150.0	-150.0 to +300.0	±0.1%FS	
	P36	99	-50.0 to +200.0	-50.0 to +400.0	±0.1%FS	
	P33	100	-40.0 to +60.0	-40.0 to +140.0	±0.15%FS	
	P01	101	0.0 to 100.0	0.0 to 200.0	±0.15%FS	
	P03	102	0.0 to 300.0	0.0 to 500.0	±0.1%FS	
	P05	103	0.0 to 500.0	0.0 to 900.0	±0.1%FS	

● DC current, DC voltage

Input Type			Input Range (FS)		Accuracy (under standard conditions)	
Symbol	Code	Range No.				
mA (linear)	C01	48	4 to 20 mA	Programmable range -19999 to +20000 (decimal point position can be changed)	±0.1%FS	
	Z51	52	2.4 to 20 mA		±0.1%FS	
mV	M01	49	0 to 10 mV	(decimal point position can be changed)	±0.1%FS	
	L02	50	-10 to +10 mV		±0.1%FS	
		51	0 to 100 mV		±0.15%FS	
mA (linear)	C01	128	4 to 20 mA	Programmable range -19999 to +20000 (decimal point position can be changed)	±0.15%FS	
	Z51	134	2.4 to 20 mA		±0.1%FS	
V (linear)		129	0 to 1 V	(decimal point position can be changed)	±0.1%FS	
		130	-1 to +1 V		±0.1%FS	
	V01	131	1 to 5 V		±0.1%FS	
		132	0 to 5 V		±0.1%FS	
		133	0 to 10 V		±0.1%FS	

! Handling Precautions

- The unit of code Z06 is Kelvin (K).
- The PV lower limit alarm does not occur with codes F50 and P50.
- The number of digits past the decimal point for DC current and DC voltage is programmable within the range 0 to 4.

MODEL SELECTION GUIDE

I II III IV V VI Example: DCP551A10100

I	II	III	IV	V	VI	Specifications
Basic Model No.	—	Number of PV inputs	Appended No.	Option	Additions	
DCP551	A					Digital Programmable Controller (single-loop model)
						Mark II
		1				PV input CH1
		2				PV input CH2
			0			0 (fixed)
				0		None
				1		Auxiliary output CH1
				2		Auxiliary output CH2, communications
					00	None
					D0	Inspection Certificate

EXTERNAL DIMENSIONS

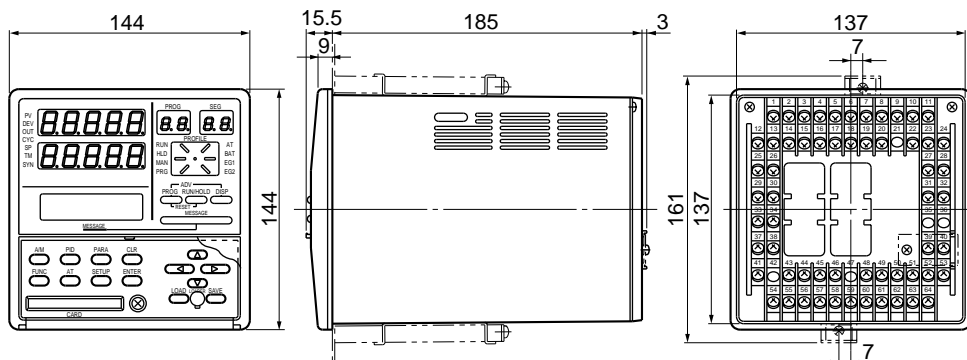

PANEL CUTOUT

(Unit: mm)

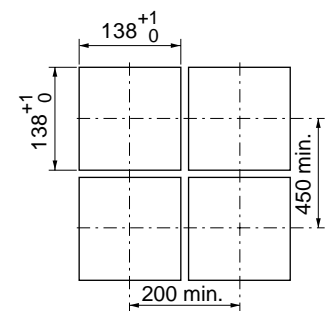

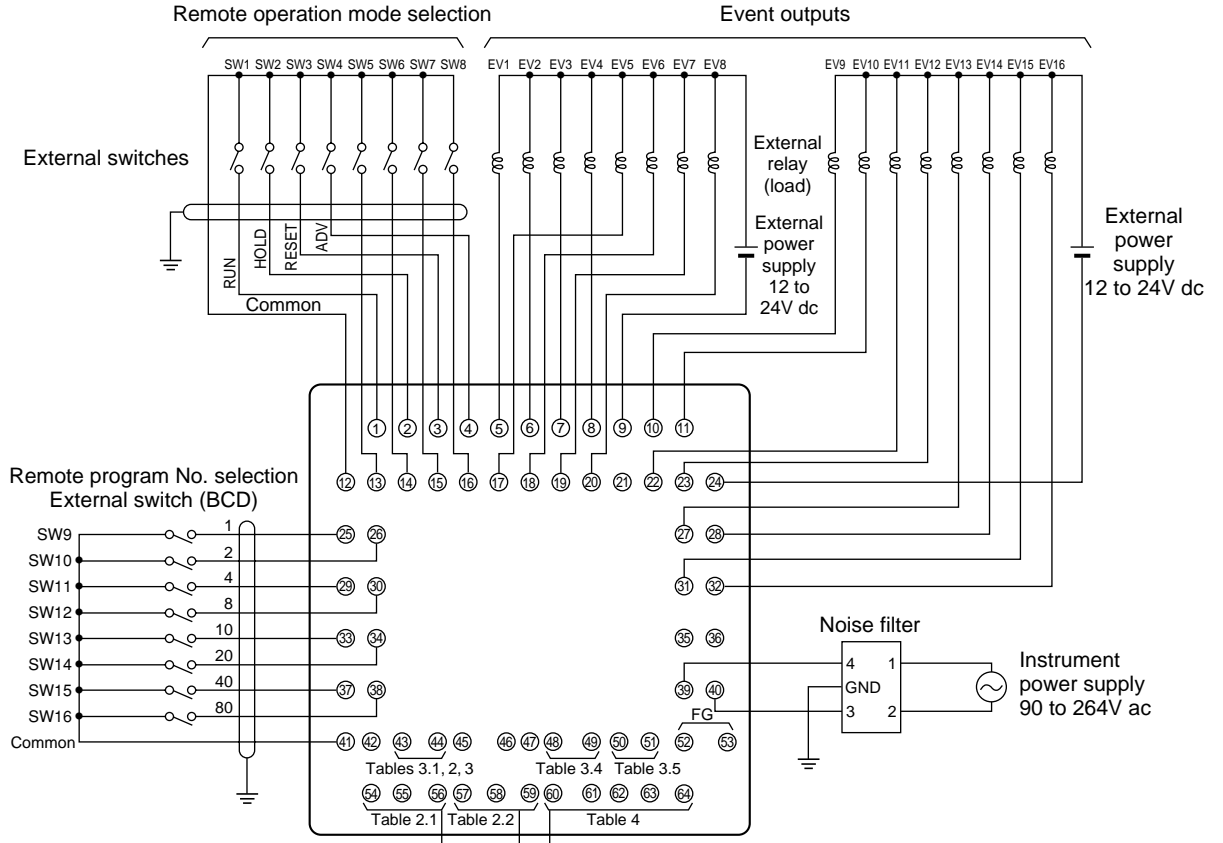

Table 2 PV input

1. ch 1			
Thermocouple	Resistance temperature detector (RTD)	Voltage (mV/V)	Current (mA)
2. ch 2			
Thermocouple	Resistance temperature detector (RTD)	Voltage (mV/V)	Current (mA)

Table 3 Control, Setup and Auxiliary Output

1. Transistor Open Collector	2. Voltage	3. Current
Control output	Control output	Control output/ Setup output
4. Current	5. Current	
Auxiliary output CH1	Auxiliary output CH2	

Continued on following page

Table 4 Communications I/O

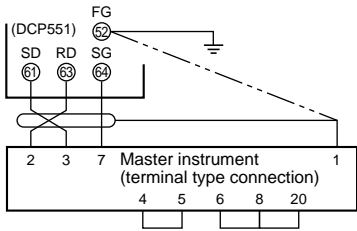
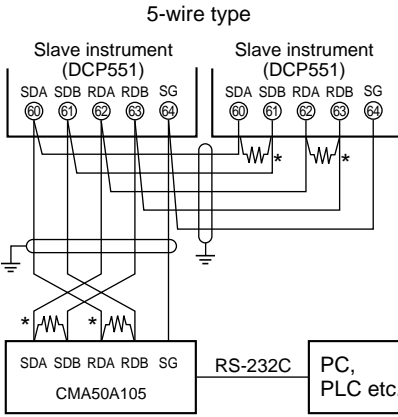
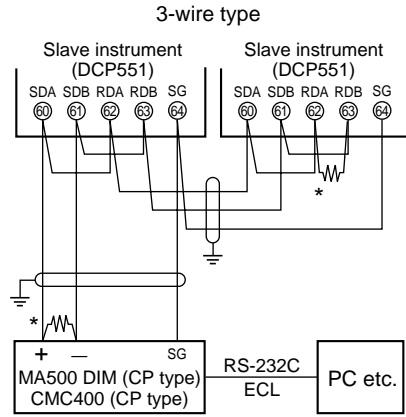
RS-232C	RS-485	
 <p>Note (1) In the case of a modem type connected master instrument, connect terminals 2 and 61, and 3 and 63 in reverse to the above figure.</p> <p>(2) The RS-232C terminals 4-5 and 6-8-20 on the computer must be short-circuited as shown in the above figure.</p> <p>(3) In the case of a computer whose RS-232C terminals 1 and 7 are for the same signal, do not connect the leads as shown in the above figure. Also, do not connect the sleeve marked "FG" to any terminal at all.</p>	<p style="text-align: center;">5-wire type</p>  <p style="text-align: center;">3-wire type</p>  <p style="text-align: center;">* Attach a terminator (1/2 W or more, 150) to both ends of the communications path.</p>	

WIRING PRECAUTIONS

1. Isolating Inputs and Outputs inside the Controller

Solid lines — show isolated items.
Dotted lines - - - - show non-isolated items.

PV input CH1	Digital circuit	Control output
PV input CH2		Auxiliary output CH1
Loader communications		Auxiliary output CH2
External switch input		
Communications		
Memory card input		Event output

2. Noise Countermeasures for Instrument Power Supplies

(1) Reducing noise

Connect the DCP551 to a single-phase power supply for instruments, and take measures to prevent the influence of electrical noise.

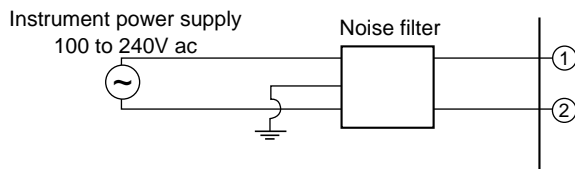

(2) When there is a lot of noise

If there is a lot of electrical noise, we recommend inserting an insulating transformer in the power circuit and using a line filter.

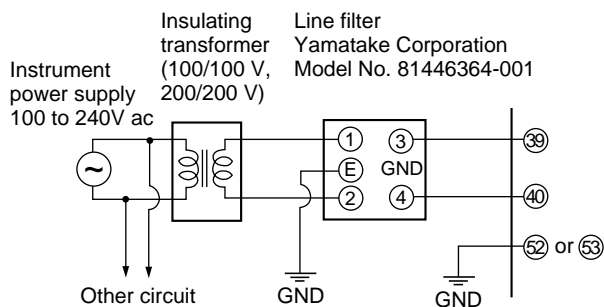

3. Noise Generating Sources and Countermeasures

Generally, the following generate electrical noise:

Relays and contacts, electromagnetic coils, solenoid valves, power lines (in particular, 90V ac min.), induction loads, inverters, motor commutators, phase angle control SCR, radio communications equipment, welding equipment, high-voltage ignition equipment

(1) Fast-rising noise

CR filters are effective in countering fast-rising noise.

Recommended CR filter:
Yamatake Corporation Model No.
81446365-001

(2) Noise with a high wave height

Varistors are effective in countering noise with a high wave height. However, note that the varistor may become short-circuited when trouble occurs. Pay attention to this when providing a varistor on a controller.

Recommended varistor:
Yamatake Corporation Model No.
81446366-001 (for 100V ac)
81446367-001 (for 200V ac)

4. Ground

Use only the FG terminal 52 or 53 on the DCP551 for grounding. Do not ground across other terminals. When it is difficult to ground shielded cable, prepare a separate GND terminal plate (earth bar).

Ground type: 100 Ω max.
Ground cable: 2 mm² min. annealed-copper wire (AWG14)
Cable length: Max. 20 m

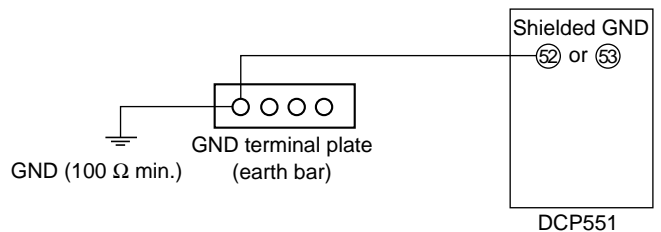

5. Precautions during Wiring

- (1) **After providing anti-noise measures**, do not bundle primary and secondary power leads together, or pass them through the same piping or wiring duct.
- (2) Maintain a distance of at least 50 cm between **I/O signal leads or communications leads and the power lead**. Also, do not pass these leads through the same piping or wiring duct.

6. Inspection after Wiring

After wiring is completed, be sure to inspect and check the wiring state. Wrong wiring may cause controller malfunction or accidents.

Specifications are subject to change without notice.

YAMATAKE

Yamatake Corporation

Savemation

IBD Sensing and Control Department

Totate International Building

2-12-19 Shibuya Shibuya-ku Tokyo 150-8316 Japan

Phone: 81-3-3486-2311

Fax: 81-3-3486-2300

Printed in Japan. (H)
1st Edition: Issued in June, 1998