

Yamatake-Honeywell

The DCP511 is a microprocessor-based digital program controller. This device not only has all the functions of conventional program controllers but also outstanding new multiple functions, low price, easy-to-use key operation and high accuracy.

The DCP511 has the capability to control process variables such as temperature, pressure, flow, number of rotations, etc. Any time sequence of set points (pattern) can be programmed from the operator keyboard.

Optimum control is achieved by PID control algorithm.

KEY FEATURES:

- Large capacity memory can memorize up to 9 patterns
- Programmable PID/output limiter function
- Programmable guaranteed soak
- Programmable range for linear input signal
- Wide variety of event functions
- Remote operation
- PV value program start function
- Self-diagnostics
- Balanceless and bumpless type Auto/Manual changeover
- Compact in size and light in weight (2.5kg)
- Noise interference prevention using input/output photo-isolators

Digitronik Line

DIGITAL PROGRAM CONTROLLER DCP511

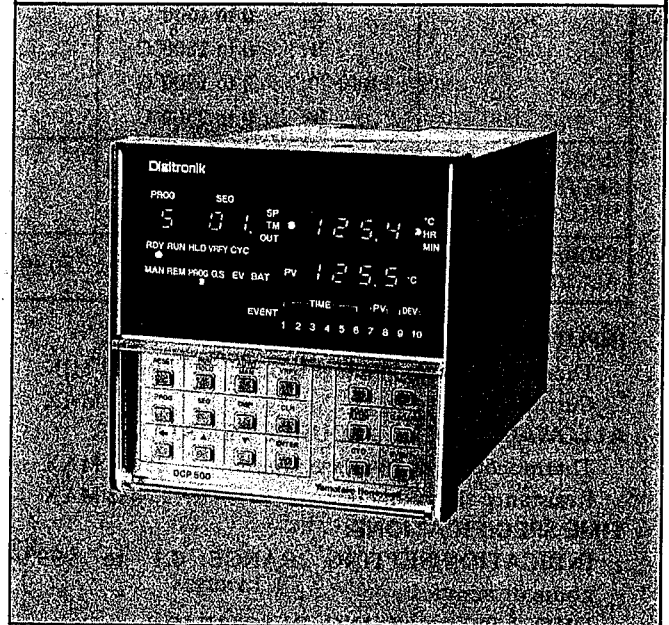

Contents:

SPECIFICATIONS	2	9. Programmable Range	28	6. Program Editing	40
PROGRAMMING		10. Setting Cycle Time	28	7. Deletion of Program Pattern	40
DEMONSTRATION	3	(Time-proportional output only)		A. Deletion of All Patterns	
DIMENSIONS OF DCP511 AND PANEL		SETTING PROGRAM PATTERN	29	B. Deletion of Only One Pattern	
CUTOUT DIMENSIONS	4	1. Sample Program	29	SETTING AND VERIFICATION OF CONTROL CONSTANTS	40
INSTALLATION	5	2. Setting Sample Program	30	1. Setting of PID Values	40
WIRING	5	3. Deletion of Segment during Programming	34	2. Setting Output Limiter Values	41
DISPLAY AND KEYBOARD	8	4. Verifying Content of Sample Program	35	ERROR CODES	42
1. Front Panel Configuration	8	OPERATION OF PROGRAM	37	ALARM CODES	43
2. Indicators	8	1. Starting Program	37	MAINTENANCE AND SERVICE	44
3. Program Function Keys	9	A. To Start from Segment 1 in the Program Pattern		1. Operation of Program No. "0"	44
INTERNAL SELECTOR SWITCHES	11	B. To Start from a Point Other than Segment 1		2. Cleaning Front Mask	44
FUNCTION AND SETTING METHOD	12	C. To Start from PV Value Point in the Program Pattern		3. Replacing Battery	44
1. DCP511 Memory Capacity	12	2. Stopping and Restarting from HOLD Condition	38	GLOSSARY OF SPECIAL TERMS	45
2. Time Events	12	3. Resetting Program	38	DCP511 MODEL SELECTION GUIDE	47
3. PV Events	15	4. Auto/Manual Operation	38	DCP500 PROGRAM WORKSHEET	48
4. DEV Events	18	5. Remote Operation	39		
5. Guaranteed Soak	20				
6. Cycling	22				
7. Programmable PID	27				
8. Programmable Output Limiter	27				

SPECIFICATIONS

INPUT SPECIFICATIONS:

	INPUT TYPE		
	THERMOCOUPLE	RESISTANCE THERMOMETER	CURRENT/VOLTAGE
INDICATION SETTING RANGE	T: -200 to 300°C J: 0 to 400°C E: 0 to 400°C 0 to 800°C K: 0 to 600°C 0 to 1200°C S: 0 to 1600°C R: 0 to 1600°C B: 0 to 1800°C PR40-20: 0 to 1800°C W: 0 to 2300°C	JIS Pt 100Ω -180.0 to 200.0°C 0.0 to 500.0°C JIS Ni 508Ω -50.0 to 150.0°C	TYPE OF INPUT SIGNAL: 4 to 20mA D.C LINEAR 1 to 5V D.C LINEAR 0 to 10mV D.C LINEAR PROGRAMMABLE RANGE: (CHANGED BY DECIMAL POINT LOCATION PARAMETER KEY) -1.799 to 7.999 -17.99 to 79.99 -179.9 to 799.9 -1799 to 7999
INDICATION SETTING RESOLUTION	1°C	0.1°C	0.001/0.01/0.1/1 (CORRESPOND TO THE ABOVE PROGRAMMABLE RANGES RESPECTIVELY)
INDICATION ACCURACY	±0.1% F.S ±1 DIGIT (AT23°C ±1°C)		

INPUT IMPEDANCE:

Thermocouple and voltage inputs: 500kΩ MIN
 Current input: 50Ω MAX

ALLOWABLE SIGNAL SOURCE RESISTANCE:

Thermocouple and voltage inputs: 250Ω MAX
 Resistance thermometer: 4Ω MAX

TIME SPECIFICATIONS:

INDICATION/SETTING RANGE: 0.1 to 999.9 hours or minutes.

INDICATION/SETTING RESOLUTION: 0.1 hours or minutes.

INDICATION ACCURACY: Within ±0.005% of the reading. (At ambient temperature 23°C±1°C)

PROGRAM MEMORY: 9 patterns (99 segments/pattern)
 Total 220 segments MAX.

RAMP SETTING RANGE:

0.1 to 999.9°C/MIN. or HOUR (T/C, RTD inputs)

SOAK TIME RANGE:

0.1 to 999.9 Min. or hours per segment.

CONTROL CONSTANT:

Proportional band: 1.0 to 1000% (1% resolution)

Reset time: 0, 1 to 1800 sec. (1 sec. resolution)
 "0" means reset action OFF.

Rate time: 0, 1 to 600 sec. (1 sec. resolution)
 "0" means rate action OFF.

Normal/Reverse operation: Selectable by DIP switch

CONTROL OUTPUT:

4 to 20 mADC (Load current of 600Ω MAX) or time proportional open-collector.

CYCLE TIME:

3, 6, 9, 12, 15, ... 60 sec. (Multiples of 3)

AUTO/MANUAL CHANGEOVER:

Balanceless and bumpless type changeover.

EVENT OUTPUTS:

Open-collector transistor output 24VDC, 75mA MAX
 Total 10 points (TIME 6, PV 2, and DEV 2)
 PV/DEV event hysteresis; ±2°C (fixed).

ALARM OUTPUT:

1 channel voltage output (OFF for abnormal condition), Allowable load of 1kΩ to 10kΩ, Output performance of 14V DC, 9mA (at 1.5kΩ load)

BURNOUT: Upscale (Thermocouple input)

CYCLING NUMBER: 9999 cycles MAX

REMOTE OPERATION:

RUN, HOLD, RESET and Program pattern selection

MEMORY BACK-UP PERIOD BY BATTERY:

3 years after MFG. date

INPUT SAMPLING CYCLE: 250m Sec.

OUTPUT RENEWAL CYCLE: 1 Sec.

ALLOWABLE AMBIENT CONDITIONS:

0 to 50°C, and lower than 90%RH at 40°C

POWER SUPPLY VOLTAGE:

100/110, 200/220, 120 and 240VAC, 50/60Hz

ALLOWABLE POWER SUPPLY VARIATIONS:

90 to 121V at 100V rating

180 to 242V at 200V rating

POWER CONSUMPTION: 20VA (at rated power)

VIBRATION RESISTANCE: 0.5G MAX (10 to 60Hz)

SHOCK RESISTANCE: 50G MAX

INSULATION RESISTANCE:

50MΩ MIN between case and each terminal (DC500V megger)

WITHSTAND VOLTAGE:

1500VAC for 1 minute between case and power supply terminal

WEIGHT: About 2.5kg

COLOR: Moss-green

ACCESSORY KIT:

Panel Mounting Brackets and Instruction Manual.

PROGRAMMING DEMONSTRATION

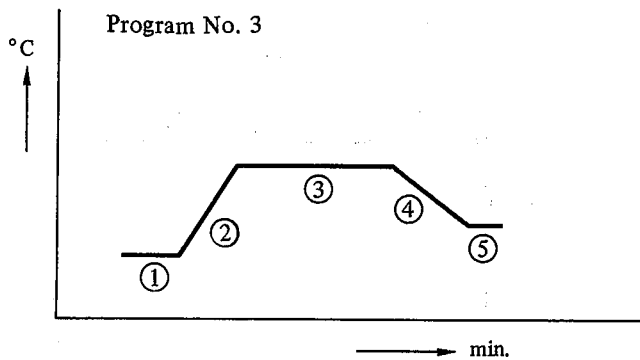

- Segment ① Soak 60°C, 0.5 min.
- ② Ramp 100°C/min.
- ③ Soak 160°C, 1.0 min.
- ④ Ramp 80°C/min.
- ⑤ Soak 100°C, 0.1 min.

1. PROG

PUSH-PUSH

Program No. 3 call

2.

← PROG
 and

Program mode

3.

SOAK RAMP
 → ← ▲ ▼ ENTR
60°C
 ← ▲ ▼ ENTR
0.5 min.

Segment ① entry

4.

SEG SOAK RAMP
 → ← ▲ ▼ ENTR
100°C/min.

Segment ② entry

5.

SEG SOAK RAMP
 → ← ▲ ▼ ENTR
160°C

Segment ③ entry

6.

SEG SOAK RAMP
 → ← ▲ ▼ ENTR
80°C/min.

Segment ④ entry

7.

SEG SOAK RAMP
 → ← ▲ ▼ ENTR
100°C

Segment ⑤ entry

8.

PROG

Entry data stored in the memory.

DIMENSIONS OF DCP511 AND PANEL CUTOUT DIMENSIONS

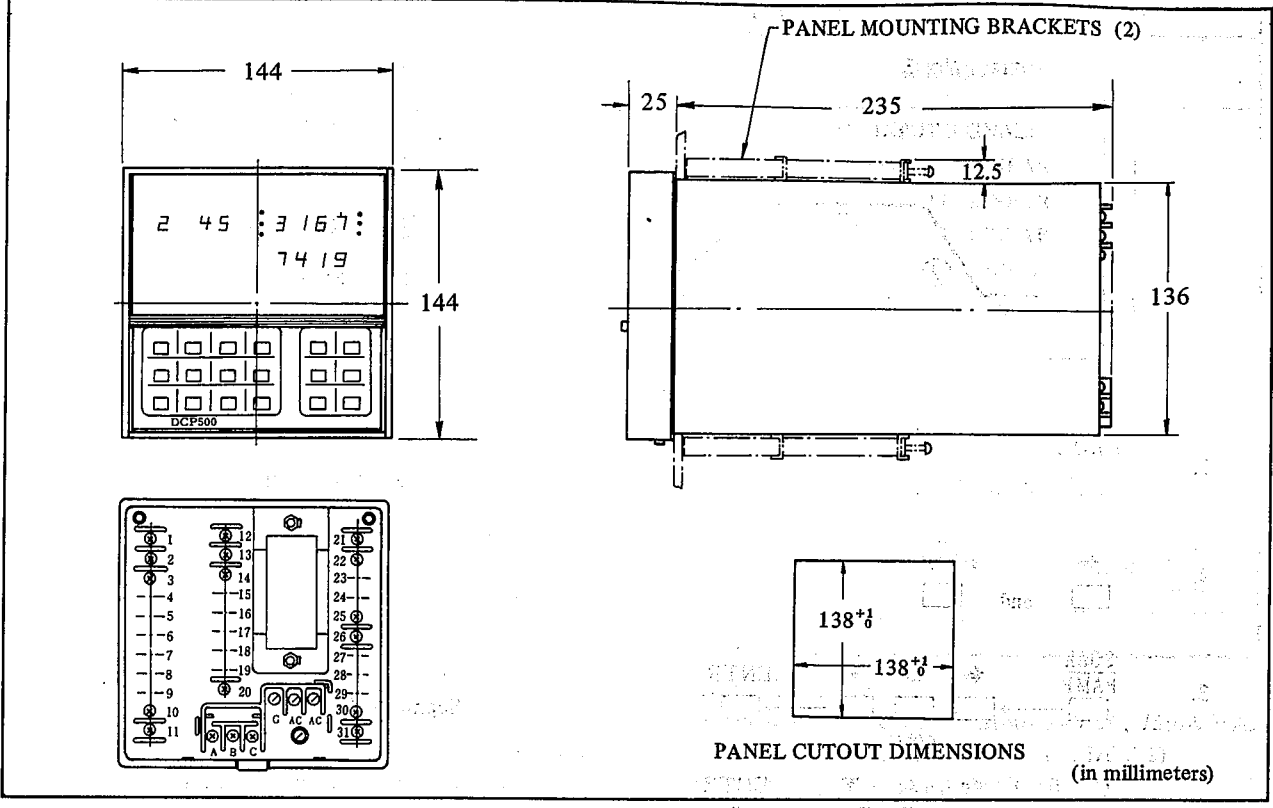

Fig. 1 External Dimensions & Panel Cutout Dimensions

INSTALLATION

(1) Environment

An extreme high temperature, high humidity, or dusty or corrosive atmosphere should be avoided. The ideal place is where the air is clean and dry and the temperature is stable. **The allowable ambient temperature and humidity are 0 to 50°C and less than 90% RH.** The vibration resistance of instrument is more than 0.5 G (10 to 60 Hz).

(2) Installation Method (See Fig. 2)

The DCP511 is flush-mounted on a panel with panel mounting brackets at the top and bottom of the instrument housing. The customer terminals are located at the rear of the instrument.

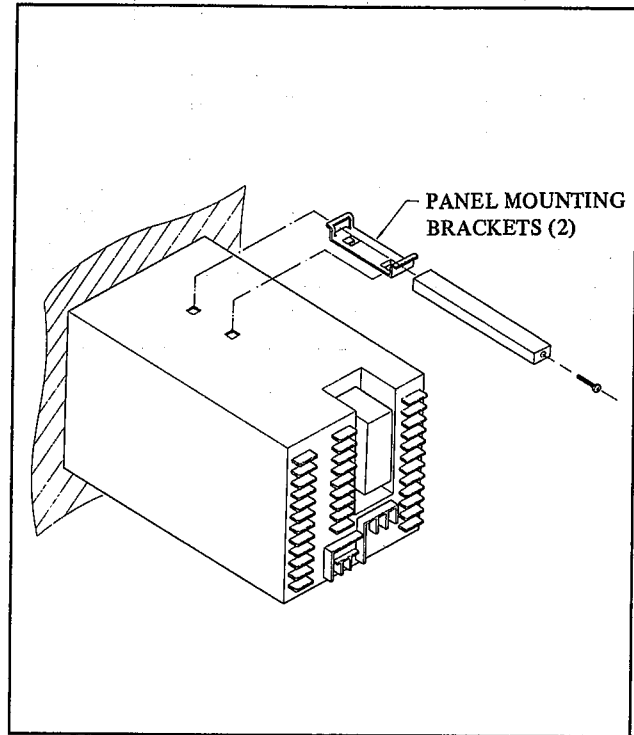

Fig. 2 Installation Method

WIRING

1. Wiring Precaution

- (1) All wiring must conform to local codes and practices.
- (2) For the input signal wiring, use shielded cable as far as possible. (Recommend use of JIS 364 twisted-pair polyethylene insulated and sheathed cable with shield) Separate the input signal cable from the power line by more than 50cm.
- (3) For the output signal wiring, follow the same method as above item (2). For relay outputs, use 600V grade polyvinyl chloride insulated wires.
- (4) For the power cable, use 600V grade polyvinyl chloride insulated wire. Use a line filter if the surge from the power line is large. (Recommend use of ZAC2205-00 made by TDK.)
- (5) Install a CR suppressor or a surge absorber on noise sources like electromagnetic contactors, motors, etc. as necessary. For sharp surges, a CR suppressor is effective. For a pulse type surge of a high peak value, a varistor is more effective.
- (6) Connect wires in accordance with the terminal symbols for external wiring. Use solderless terminals for connections.
- (7) Supply the correct voltage for the particular model number; 100/110V, 200/220V, 120V or 240V.
- (8) No power supply switch and fuse are provided in the DCP511. If required they must be provided externally.
- (9) The wiring between instrument and thermocouple or resistance thermometer must not run in the same conduit as the power cable.
- (10) Also pay attention to the panel wiring for above item (7).

Table 2. Specifications of Compensation Wires

Type	Thermocouple To Be Used	Symbol	Use	Temperature Range (°C)	Surface Insulator Color
Wire for R	R (PR)	RX-G	Regular	0 to 90	Black
		RX-H	High temp.	0 to 150	
Wire for K	K (CA)	KX-G	Regular	-20 to 90	Blue
		KX-H			
		KX-H	High temp.	0 to 150	
		KX-HS			
Wire for E	E (CRC)	EX-G	Regular	-20 to 90	Purple
		EX-H	High temp.	0 to 150	
Wire for J	J (IC)	JX-G	Regular	-20 to 90	Yellow
		JX-H	High temp.	0 to 150	
Wire for T	T (CC)	TX-G	Regular	-20 to 90	Brown
		TX-H	High temp.	0 to 150	

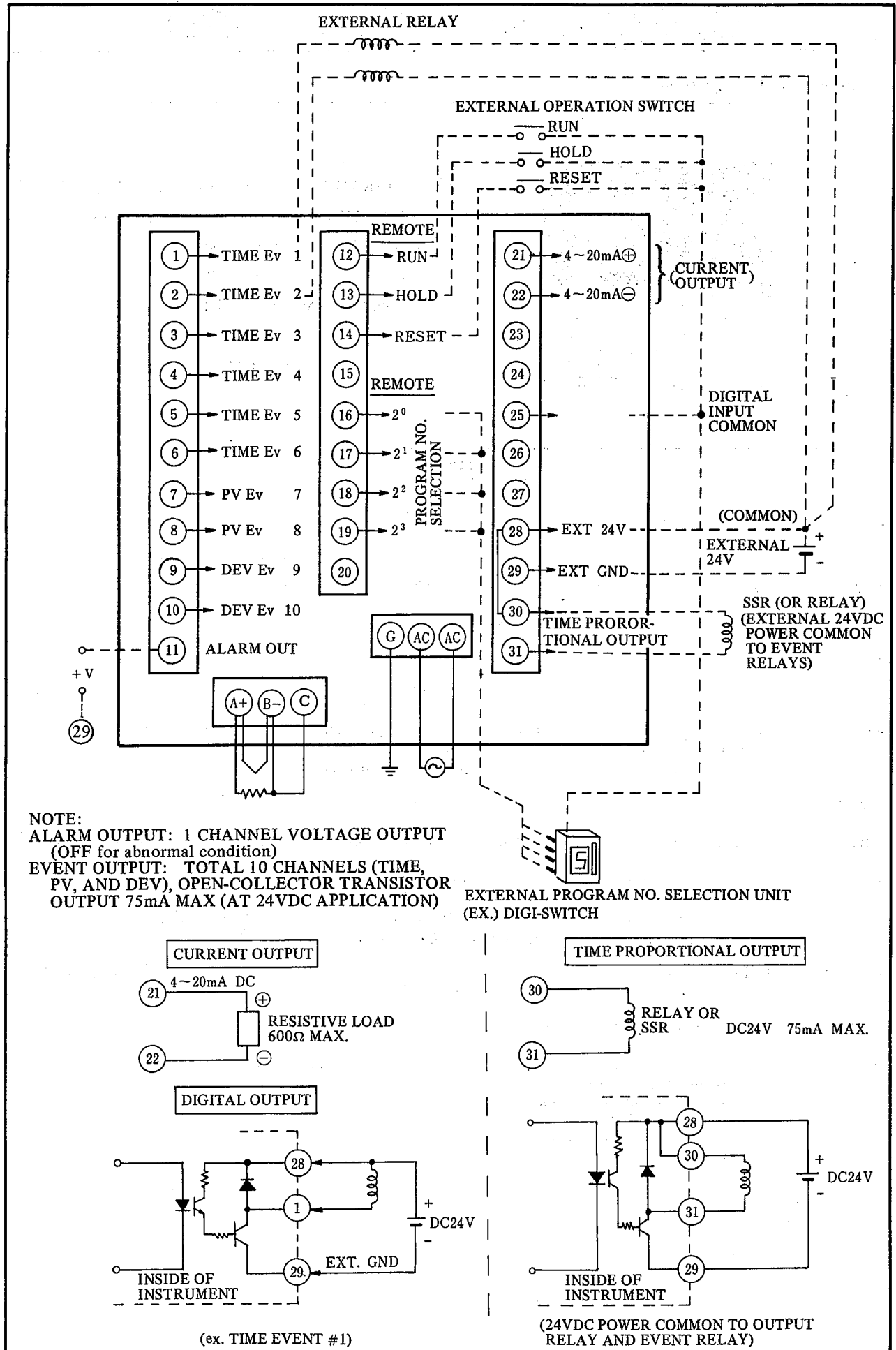

Fig. 3 Wiring Diagram

DISPLAY AND KEYBOARD

1. Front Panel Configuration

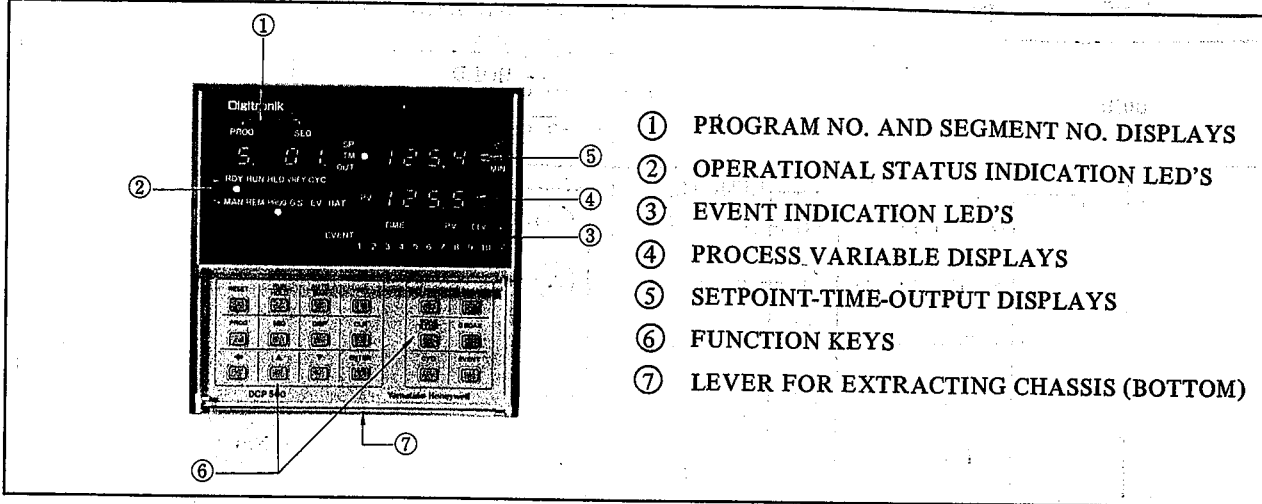

Photo. 1

2. Indicators

- RDY Lights to indicate instrument is in READY mode. (Control is stopped.)
- RUN Lights to indicate instrument is in RUN mode.
- HLD Lights to indicate instrument is in HOLD mode.
- VRFY Lights to indicate instrument is in VERIFY mode.
- CYC Lights to indicate CYCLE function is being programmed during program setting, or CYCLE program is being recalled in VERIFY mode.
Lights to indicate CYCLE function is being executed in RUN mode.
- MAN Lights to indicate instrument is in MANUAL mode.
- REM Lights to indicate instrument is being controlled by external switches (RESET, RUN OR HOLD).
- PROG Lights to indicate programming mode of operation.
- G·S Lights to indicate event function (TIME, PV or DEV) is being programmed during program setting or the event function is being recalled in VERIFY mode.
- EV Lights to indicate event function (TIME, PV or DEV) is being programmed during program setting or the event function is being recalled in VERIFY mode.
- BAT Lights to indicate battery power is down.
- SP Flashes to indicate SP value is being programmed during program setting.
Both SP and TM LED's flash during RAMP rate setting.
SP LED lights at SP value display in VERIFY mode.
Both SP and TM LEDs light at RAMP rate value display.
SP LED lights at SP value display in RUN mode.
- TM Flashes to indicate SP holding time and Time Event ON/OFF time are being programmed during program setting.
Lights at display of remaining time in SOAK segment in RUN mode.
See above item SP.
- OUT Lights to indicate output variable is being displayed in AUTO or MANUAL mode.
- °C Lights to indicate instrument is indicating temperature setting value, ramp setting value or PV/DEV event setting value.

- HR MIN Lights to indicate HR or MIN indicated during program setting meets with the time unit selected by internal DIP switch.
Lights to indicate HR or MIN indicated in RUN mode meets with the time unit set in program. HR or MIN lights when TM LED is flashing.
- TIME Lights to indicate the selected TIME event No. during program setting or in VERIFY mode.
Lights when the programmed event is ON in RUN mode.
- PV Lights to indicate the selected PV event No. indicated during program setting or in VERIFY mode.
Lights when the programmed event is ON in RUN mode.
- DEV Lights to indicate the selected DEV event No. during program setting or in VERIFY mode.
Lights when the programmed event is ON in RUN mode.

3. Program Function Keys

- RESET** Places instrument in READY mode.
When reset is made in **RUN/HOLD** mode, press **RESET** key with key pressed.
- RUN/HOLD** Selects alternately RUN or HOLD mode.
Operates as **RUN** key after pressing **RESET** key.
RUN key is pressed to place instrument in RUN mode in accordance with a selected program when the instrument is in READY or HOLD mode.
HOLD key is pressed to place instrument in HOLD mode when the instrument is in RUN mode.
HOLD mode – This is a condition under which a progressing program and time event are stopped and control is being done at the SP value at the time the instrument was placed in the HOLD mode.
- AUTO/MAN** Selects alternately AUTO or MANUAL mode.
In AUTO mode, output variable is computed by control.
IN MANUAL mode, output variable is a value adjusted by and key manual operation.
MANUAL operation is possible in READY mode.
- VRFY** Used to verify or edit a stored program.
- ← This is a shift key to define the location of a figure which is incremented or decremented by or key.
Used to register a program by pressing **PROG** key with key pressed, or to start a program from a PV value by pressing **RUN/HOLD** key with key pressed.
- PROG** Used to define the number of a program to be executed, or used for program setting.
By pressing the key repetitively, the program No. advances in order 1, 2, 3, , 9, 0, 1, 2,
When **PROG** key is pressed with key pressed, the condition for program setting can be obtained.
- SEG** Used to define the number of the segment to be executed.
Used also to define the division of each segment at program setting.
When **SEG** key is pressed with **CLR** key pressed, the program data for the segment being displayed is deleted.

DISP

Used to select the type of data to be indicated on the display.
 The initial condition is SP display mode. By alternate switching operations, the mode is changed to output display mode.
 Used to return the condition from various VERIFY/PID/PARA key operations condition to an initial condition.

CLR

Used to delete or initialize the value at setting.
 When **PROG** key is pressed with **CLR** key pressed, the data for the selected program No. is deleted.

Increment and decrement keys to increase or decrease the data such as numerical value or event No. to be set.

ENTR

Used to store the numerical value set, or to renew data in VERIFY mode.

PID

Used to set PID parameter (maximum 3 groups) values in READY mode.
 Used to tune a selected PID parameter value in RUN mode.
 Used to define the group of PID parameters to be used for program entry.

PARA

Used to set various parameter values in READY mode.

SOAK

RAMP

Used to define soak or ramp during programming.
 Used to select alternately SOAK or RAMP.
 When **G.SOAK** key is pressed, the mode after the next pressing of **SOAK/RAMP** key is RAMP mode.

G-SOAK

Used to define a guaranteed soak during programming a pattern.

CYC

Used to define a cycling of all or of a portion of a program

EVENT

Used to define various (TM, PV and DEV) events at programming.

INTERNAL SELECTOR SWITCHES

1. Table for DIP Switch Configurations

DIP SWITCH (SW1)

H: Switch circuit closed (ON)
L: Switch circuit opened (OFF)
X: Not defined

1	2	3	4	5	6	7	8	FUNCTION	SELECTION
X	X	X	X	X	X	X	H	HR	TIME UNIT
X	X	X	X	X	X	X	L	MIN	
X	X	X	X	X	X	X	H	± 1°C	GUARANTEED SOAK BAND
X	X	X	X	X	X	X	L	± 5°C	
X	X	X	X	H	H	X	X	LARGE	INPUT DIGITAL FILTER
X	X	X	X	L	H	X	X	MIDDLE	
X	X	X	X	H	L	X	X	SMALL	
X	X	X	X	L	L	X	X	OFF	
X	X	X	H	X	X	X	X	3 GROUPS	PID PARAMETER GROUPS
X	X	X	L	X	X	X	X	1 GROUP	
X	X	H	X	X	X	X	X	NORMAL	CONTROL TYPE
X	X	L	X	X	X	X	X	REVERSE	
X	H	X	X	X	X	X	X	DOWNSCALE	BURNOUT DIRECTION
X	L	X	X	X	X	X	X	UPSCALE	
H	X	X	X	X	X	X	X	YES	PROGRAM START FROM PV VALUE
L	X	X	X	X	X	X	X	NO	

(Instrument is shipped with all L positions.)

DIP SWITCH (SW2)

1	2	3	4	5	6	7	8	FUNCTION	
X	X	X	X	L	L	L	L	0 to 600°C	K
X	X	X	X	L	L	L	H	0 to 1200	K
X	X	X	X	L	L	H	L	-180 to 200	Pt100Ω
X	X	X	X	L	L	H	H	0 to 500	Pt100Ω
X	X	X	X	L	H	L	L	0 to 400	E
X	X	X	X	L	H	L	H	0 to 800	E
X	X	X	X	L	H	H	L	0 to 1600	R
X	X	X	X	L	H	H	H	0 to 400	J
X	X	X	X	H	L	L	L	0 to 2300	W
X	X	X	X	H	L	L	H	0 to 1800	B
X	X	X	X	H	L	H	L	-200 to 300	T
X	X	X	X	H	L	H	H	0 to 1600	S
X	X	X	X	H	H	L	L	0 to 1800	PR40-20
X	X	X	X	H	H	L	H	-50 to 150	Ni508Ω
X	X	X	X	H	H	H	H	LINEAR INPUT	

DIP SWITCH (SW3)

1	2	3	4	5	6	7	8	FUNCTION	
X	X	X	X	X	X	X	H	TIME PROPORTIONAL OUTPUT	
X	X	X	X	X	X	X	L	CURRENT OUTPUT	

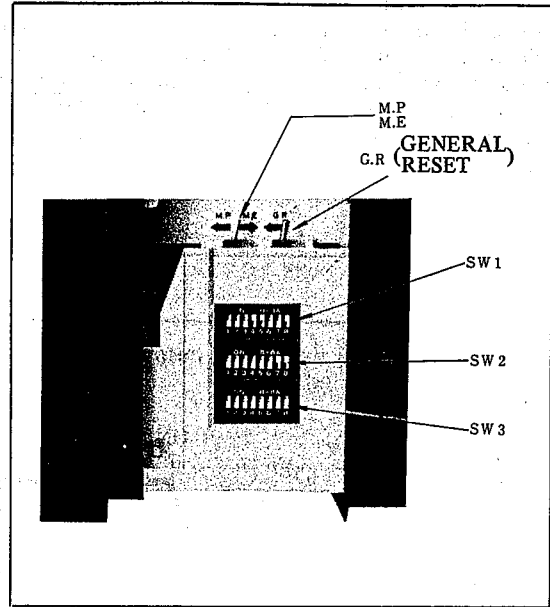
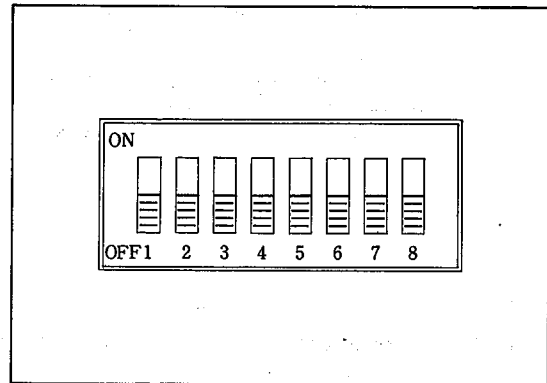

Photo. 2

DIP SWITCH ASSEMBLY



2. Internal Selector Switch Setting

M.E. (Memory Enable):

Set switch to M.E. position during editing of program content or program writing.

M.P. (Memory Protection):

If switch is set to M.P. position, the content of the stored program cannot be edited. This is used when a change of program pattern is not desired.

G.R. (General Reset):

When memory switch is set to M.E. position and then G.R. switch is set to the arrow mark position, all stored program patterns are deleted.

FUNCTION AND SETTING METHOD

1. DCP 511 Memory Capacity

The DCP 511 has a maximum memory capacity of 1800 bytes in up to 9 programs. This is equivalent to about 200 segments. The number of bytes shown in the right table is used for each function. A certain number of bytes are used at each program entry. The number of remaining bytes is displayed in a variable display at each push of [SEG] key. If the quantity of remaining bytes is insufficient at entry of new program, one of the programs already stored must be deleted.

FUNCTION	REQUIRED BYTES
DEFINING PROGRAM AND STORAGE	5 BYTES
SOAK AND GUARANTEED SOAK	5 BYTES
RAMP	3 BYTES
CYCLE	3 BYTES
PID (DEFINING 2 OR 3)	3 BYTES
EVENT	6 BYTES

2. Time Events

DCP 511 can produce 6 time event outputs.

(Example)

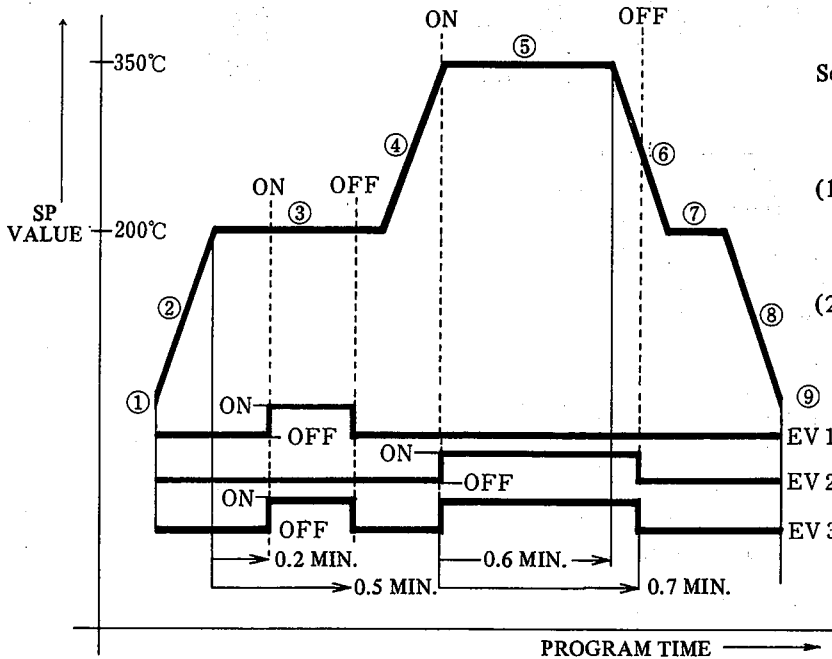

SEGMENT ③ :
TIME EVENT EV1
ON after 0.2 Min.
OFF after 0.5 Min.

Segment ⑤ :
TIME EVENT EV2
ON after 0.0 Min.
OFF after 0.7 Min.

- (1) On and OFF times of events are measured from the start of the segment in which they are entered.
- (2) The start and end of any event can be programmed to occur at any point in the program after the start of the segment in which they are entered. In the case of EV2, OFF is programmed to occur beyond the time of segment ⑤. However, OFF cannot be programmed to occur beyond the end of the program pattern; in this case, the time event will be OFF simultaneously with the end of the final segment.

- (3) Time event can be set in a RAMP segment.
- (4) An identical event can be set to occur in other segment like EV3 (Example). (However, an identical event cannot be programmed to occur or more than one time in one segment.)
- (5) Multiple events with different event numbers can be set to occur in one segment for example segments ③ and ⑤ in the above program.

Time Event EV2 Setting Procedure

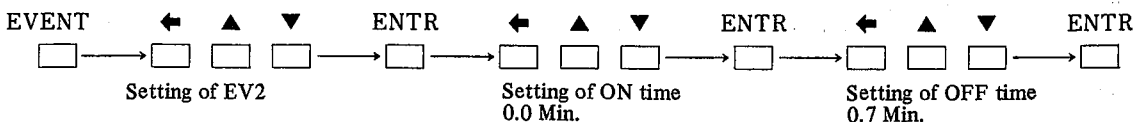

Time Event EV1 Setting Procedure: (See sample program pattern used in item 2.)

FUNCTION	DATA ENTRY	DISPLAY	INDICATOR
(For segments ① and ②, refer to the Chapter SETTING PROGRAM PATTERN).			
SEG <input type="checkbox"/>		03. <input type="text"/> <input type="text"/> <input type="text"/> <input type="text"/> (NUMBER OF REMAINING BYTES)	RDY PROG MIN
SOAK RAMP <input type="checkbox"/>		Flashing <input type="text"/> <input type="text"/> <input type="text"/> <input type="text"/>	RDY PROG MIN SP
	← ▲ ▼ ENTR <input type="text"/> <input type="text"/> <input type="text"/> <input type="checkbox"/> 2 0 0	Flashing <input type="text"/> <input type="text"/> <input type="text"/> <input type="text"/>	RDY PROG MIN TM
	← ▲ ▼ ENTR <input type="text"/> <input type="text"/> <input type="text"/> <input type="checkbox"/> 0. 6	<input type="text"/> <input type="text"/> <input type="text"/> <input type="text"/>	RDY PROG MIN TM
EVENT <input type="checkbox"/>		Flashing <input type="text"/> <input type="text"/> <input type="text"/> <input type="text"/>	RDY PROG EV
	ENTR <input type="checkbox"/>	Flashing <input type="text"/> <input type="text"/> <input type="text"/> <input type="text"/>	RDY PROG EV TM TIME 1
(EVENT ON)	← ▲ ▼ ENTR <input type="text"/> <input type="text"/> <input type="text"/> <input type="checkbox"/> 0. 2	Flashing <input type="text"/> <input type="text"/> <input type="text"/> <input type="text"/>	RDY PROG EV MIN TM TIME 1
(EVENT OFF)	← ▲ ▼ ENTR <input type="text"/> <input type="text"/> <input type="text"/> <input type="checkbox"/> 0. 5	<input type="text"/> <input type="text"/> <input type="text"/> <input type="text"/>	RDY PROG EV MIN TM TIME 1
SEG <input type="checkbox"/>		04. <input type="text"/> <input type="text"/> <input type="text"/> <input type="text"/> (NUMBER OF REMAINING BYTES)	RDY PROG MIN
SOAK RAMP <input type="checkbox"/>		Flashing <input type="text"/> <input type="text"/> <input type="text"/> <input type="text"/>	RDY PROG MIN °C SP TM
	← ▲ ▼ ENTR <input type="text"/> <input type="text"/> <input type="text"/> <input type="checkbox"/> 4 0 0	<input type="text"/> <input type="text"/> <input type="text"/> <input type="text"/>	RDY PROG MIN °C SP TM
SEG <input type="checkbox"/>		05. <input type="text"/> <input type="text"/> <input type="text"/> <input type="text"/> (NUMBER OF REMAINING BYTES)	RDY PROG MIN
SOAK RAMP <input type="checkbox"/>		Flashing <input type="text"/> <input type="text"/> <input type="text"/> <input type="text"/> (SP VALUE OF PREVIOUS SOAK SEGMENT)	RDY PROG °C SP
	← ▲ ▼ ENTR <input type="text"/> <input type="text"/> <input type="text"/> <input type="checkbox"/> 3 5 0	Flashing <input type="text"/> <input type="text"/> <input type="text"/> <input type="text"/>	RDY PROG MIN TM
	← ▲ ▼ ENTR <input type="text"/> <input type="text"/> <input type="text"/> <input type="checkbox"/> 0. 6	<input type="text"/> <input type="text"/> <input type="text"/> <input type="text"/>	RDY PROG MIN TM

廃番

EVENT □		Flashing □□□	Flashing ○ RDY ○ PROG ○ EV
← □ ▲ □ ▼ □ ENTR □	2	Flashing □□ 0.0	○ RDY ○ PROG ○ EV MIN ○ TM ○ TIME 2
← □ ▲ □ ▼ □ ENTR □	0. 0	Flashing □□ 0.0	○ RDY ○ PROG ○ EV MIN ○ TM ○ TIME 2
← □ ▲ □ ▼ □ ENTR □	0. 7	□□ 0.7	○ RDY ○ PROG ○ EV MIN ○ TM ○ TIME 2

3. PV Events

PV event is ON when PV value goes above the set point, and OFF below the set point.

An identical PV event can be programmed to occur many times in one program pattern.

PV event can be programmed to occur in a desired segment.

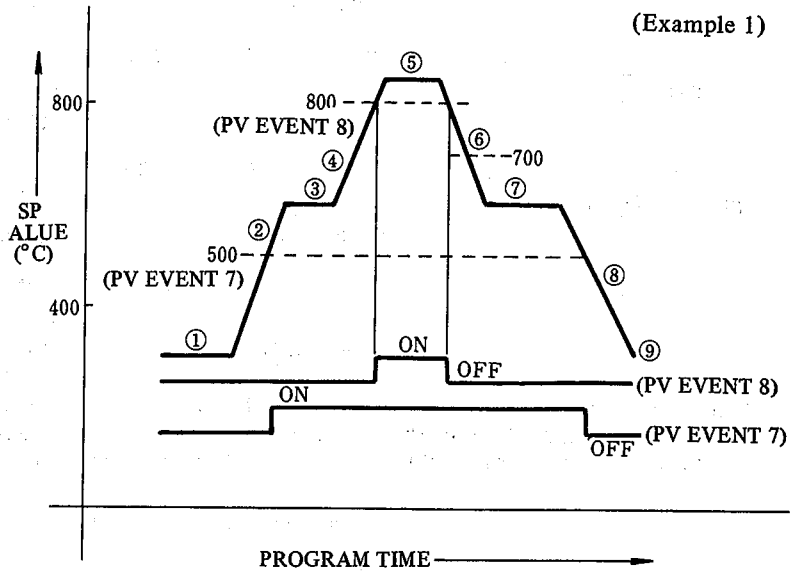

PV Event 7 Setting Procedure

(Example 1)

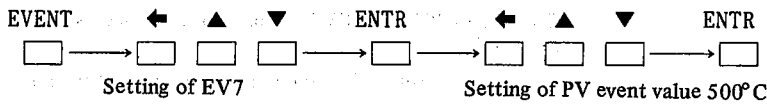

(Setting of PV event 7 at segment ② programming)

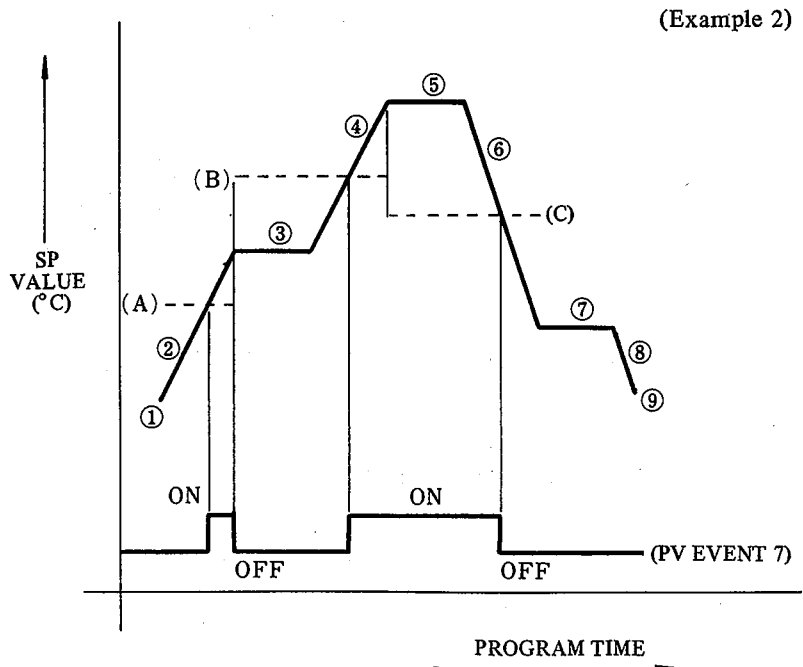

(Example 2)

(Segment ②)

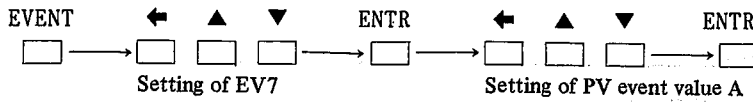

(Segment ③)

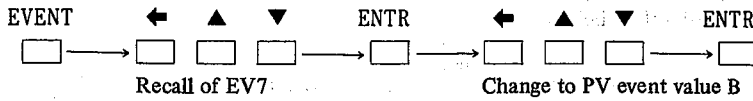

(Segment ⑤)

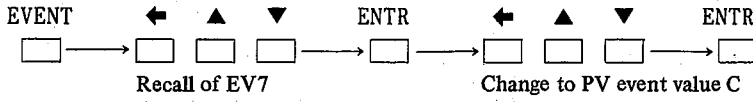

(Segment ⑦)

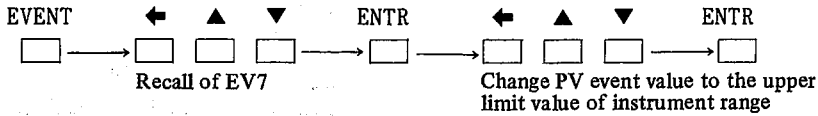

When a PV event was set in a segment but is not used in the succeeding segments, the setting must be changed to the upper limit of the instrument range as done in segment ⑦ of example 2. In addition, when event setting of another PV value is made, the setting must be changed to the desired PV value.

(Example 3)

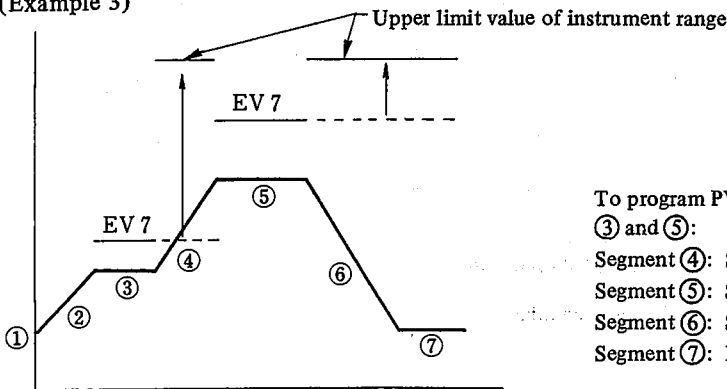

To program PV event EV7 to occur in the segments ③ and ⑤:
 Segment ④: Set EV7 to the upper limit value of the range.
 Segment ⑤: Set EV7 to the desired value.
 Segment ⑥: Set EV7 again to the upper limit value.
 Segment ⑦: EV7 setting is unnecessary.

PV Event 7 Setting Procedure: (See program pattern example 1)

FUNCTION	DATA ENTRY	DISPLAY	INDICATOR
(For entry of program No., refer to the Chapter SETTING PROGRAM PATTERN).			
SEG □		01. □□□□ (NUMBER OF REMAINING BYTES)	○ ○ ○ RDY PROG MIN
SOAK RAMP □		Flashing □□□□	○ ○ ○ RDY PROG °C SP
	← ▲ ▼ ENTR □ □ □ □ 1 0 0	Flashing □□□□	○ ○ ○ ○ RDY PROG MIN TM
	← ▲ ▼ ENTR □ □ □ □ 0. 5	□□□□	○ ○ ○ ○ RDY PROG MIN TM
SEG □		02. □□□□ (NUMBER OF REMAINING BYTES)	○ ○ ○ RDY PROG MIN
SOAK RAMP □		Flashing □□□□	○ ○ ○ ○ RDY PROG MIN °C SP TM

廃番

	<p>← ▲ ▼ ENTR</p> <p>4 0 0</p>	<p>4 0 0</p>	<p>RDY PROG MIN °C SP TM</p>
EVENT		<p>Flashing</p> <p>1</p>	<p>Flashing</p> <p>RDY PROG EV</p>
	<p>← ▲ ▼ ENTR</p> <p>7</p>	<p>Flashing</p> <p>(UPPER LIMIT VALUE OF RANGE)</p>	<p>Flashing</p> <p>RDY PROG EV °C PV7</p>
	<p>← ▲ ▼ ENTR</p> <p>5 0 0</p>	<p>5 0 0</p>	<p>RDY PROG EV °C PV7</p>
SEG		<p>0 3</p> <p>(NUMBER OF REMAINING BYTES)</p>	<p>RDY PROG MIN</p>
SOAK RAMP		<p>Flashing</p> <p>1 0 0</p> <p>(SP VALUE OF SEGMENT ①)</p>	<p>Flashing</p> <p>RDY PROG °C SP</p>
	<p>← ▲ ▼ ENTR</p> <p>6 0 0</p>	<p>Flashing</p> <p>0.0</p>	<p>Flashing</p> <p>RDY PROG MIN TM</p>
	<p>← ▲ ▼ ENTR</p> <p>0. 3</p>	<p>0.3</p>	<p>RDY PROG MIN TM</p>
SEG		<p>0 4</p> <p>(NUMBER OF REMAINING BYTES)</p>	<p>RDY PROG MIN</p>
SOAK RAMP		<p>Flashing</p> <p>0.0</p>	<p>Flashing</p> <p>RDY PROG MIN °C SP TM</p>
	<p>← ▲ ▼ ENTR</p> <p>3 0 0</p>	<p>3 0 0</p>	<p>RDY PROG MIN °C SP TM</p>
EVENT		<p>Flashing</p> <p>1</p>	<p>Flashing</p> <p>RDY PROG EV</p>
	<p>← ▲ ▼ ENTR</p> <p>8</p>	<p>Flashing</p> <p>(UPPER LIMIT VALUE OF RANGE)</p>	<p>Flashing</p> <p>RDY PROG EV °C PV8</p>
	<p>← ▲ ▼ ENTR</p> <p>8 0 0</p>	<p>8 0 0</p>	<p>RDY PROG EV °C PV8</p>

4. DEV Events

Either a plus deviation or minus deviation settings can be made to one event channel. Deviation event output is ON when the deviation input value (PV minus SP) is above the deviation set point for the plus deviation, and also when the deviation input value (PV minus SP) is below the deviation set point (with minus mark) for the minus deviation setting.

(Example 1)

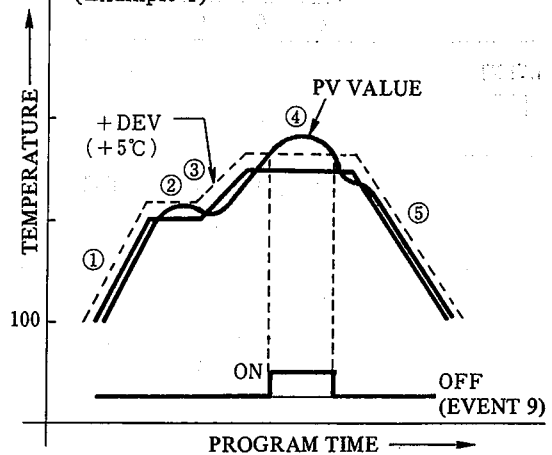

DEV Event Setting Procedure

(Example 1)

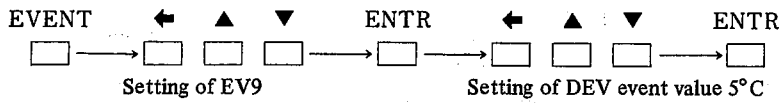

(Example 2)

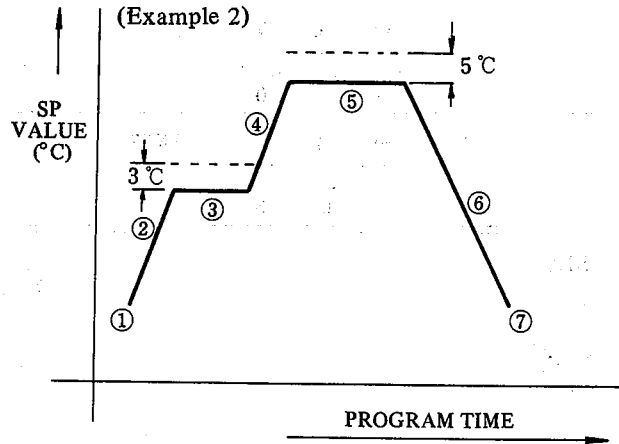

(Example 2)

To program different deviation values to occur many times for one event channel:

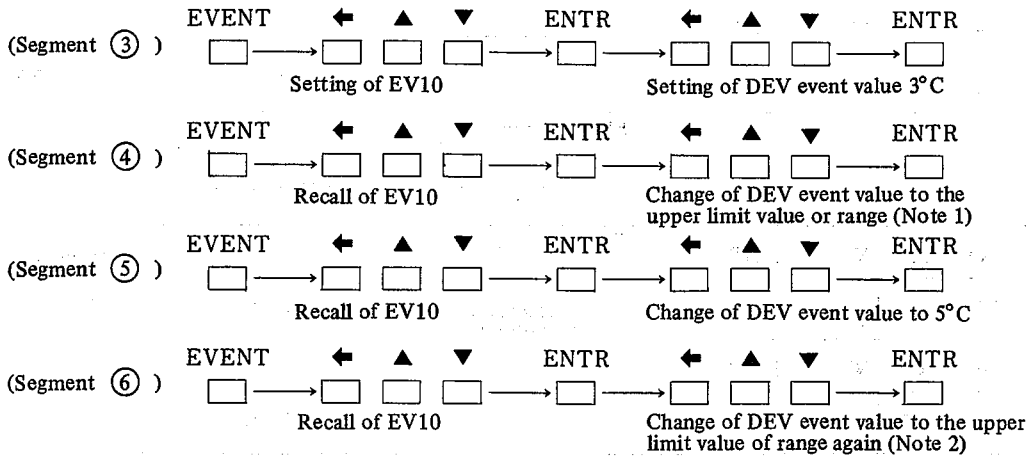

- Note: 1. By this change, DEV event is not applied to segment ④.
- 2. By this change, DEV event is not applied to both segments ⑥ and ⑦.

When DEV event was set in a segment but is not used in the succeeding segments, the setting must be changed to the upper limit of the instrument range. In addition, when event setting of another DEV value is made, the setting must be changed to the desired DEV value.

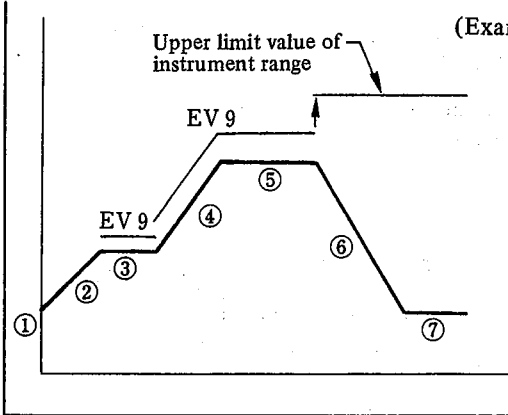

- (Example) Segment ③ : Set DEV event EV9 to +3°C.
 Segment ④ : Set DEV event EV9 to +5°C.
 Segment ⑤ : No setting change (EV9 value is +5°C).
 Segment ⑥ : Set DEV event EV9 to the upper limit value of range.
 Segment ⑦ : No setting change (EV9 value is the upper limit value of range).

DEV Event 9 Setting Procedure: (See program pattern example 1)

FUNCTION	DATA ENTRY	DISPLAY	INDICATOR
(For entry of program No., refer to the Chapter SETTING PROGRAM PATTERN).			
SEG <input type="checkbox"/>		<input type="checkbox"/> / . <input type="checkbox"/> <input type="checkbox"/> <input type="checkbox"/> <input type="checkbox"/> <input type="checkbox"/> (NUMBER OF REMAINING BYTES)	Flashing RDY PROG MIN SP
SOAK RAMP <input type="checkbox"/>		Flashing <input type="checkbox"/> <input type="checkbox"/> <input type="checkbox"/> . <input type="checkbox"/> <input type="checkbox"/>	Flashing RDY PROG °C TM
	← ▲ ▼ ENTR <input type="checkbox"/> <input type="checkbox"/> <input type="checkbox"/> <input type="checkbox"/> Soak SP value	Flashing <input type="checkbox"/> <input type="checkbox"/> <input type="checkbox"/> . <input type="checkbox"/> <input type="checkbox"/>	RDY PROG MIN TM
	← ▲ ▼ ENTR <input type="checkbox"/> <input type="checkbox"/> <input type="checkbox"/> <input type="checkbox"/> Soak time	<input type="checkbox"/> <input type="checkbox"/> <input type="checkbox"/> <input type="checkbox"/> <input type="checkbox"/> <input type="checkbox"/> Soak time	RDY PROG MIN TM
EVENT <input type="checkbox"/>		Flashing <input type="checkbox"/> <input type="checkbox"/> <input type="checkbox"/> /	Flashing RDY PROG EV
	← ▲ ▼ ENTR <input type="checkbox"/> <input type="checkbox"/> <input type="checkbox"/> <input type="checkbox"/> 9	Flashing <input type="checkbox"/> <input type="checkbox"/> <input type="checkbox"/> <input type="checkbox"/> <input type="checkbox"/> <input type="checkbox"/> (UPPER LIMIT VALUE OF RANGE)	RDY PROG EV °C DEV 9
	← ▲ ▼ ENTR <input type="checkbox"/> <input type="checkbox"/> <input type="checkbox"/> <input type="checkbox"/> 5	<input type="checkbox"/> <input type="checkbox"/> <input type="checkbox"/> <input type="checkbox"/> 5	RDY PROG EV °C DEV 9

By the above setting, DEV event of +5°C is applied to all the segment of program pattern example 1.

5. Guaranteed Soak

Guaranteed soak can be, applied or not, selected by a key operation on the front keyboard. Use G. SOAK key when guaranteed soak is applied, but use SOAK/RAMP key during SP value setting when guaranteed soak is not applied.

SELECTION OF TEMPERATURE BAND FOR GUARANTEED SOAK

Selectable by the No. 7 switch of the internal DIP switch SW1.

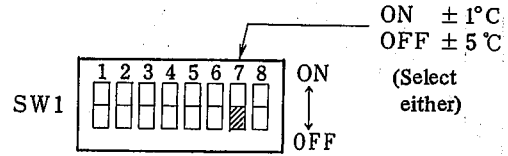

(Example)

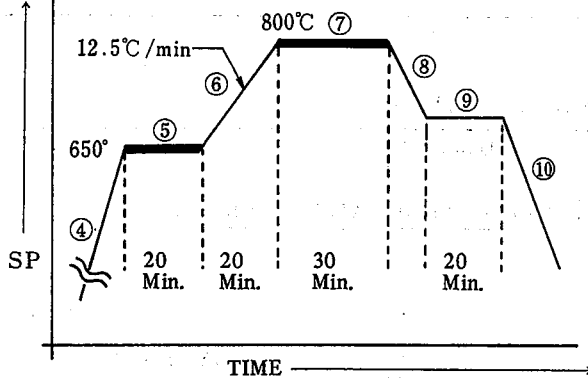

Guaranteed Soak Setting Procedure

(Example)

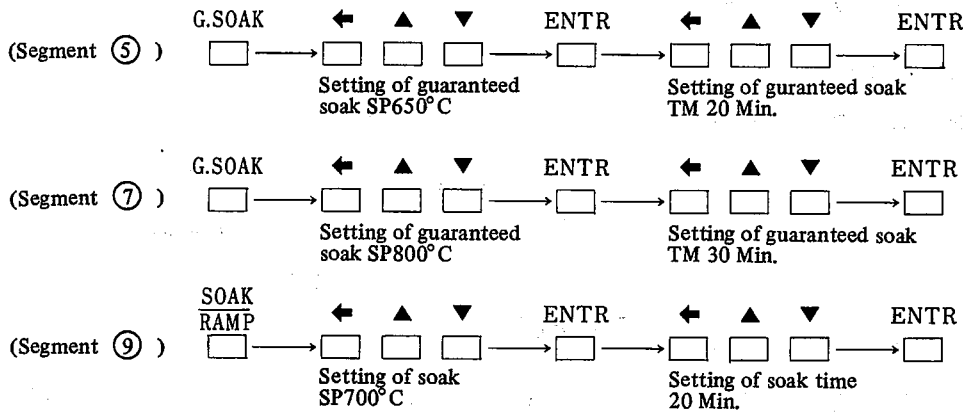

Guaranteed Soak Setting Procedure (See program pattern example)

FUNCTION	DATA ENTRY	DISPLAY	INDICATOR
SEG	<input type="text"/>	<input type="text"/> 5. <input type="text"/> <input type="text"/> <input type="text"/> <input type="text"/> (NUMBER OF REMAINING BYTES)	RDY PROG MIN
G.SOAK	<input type="text"/>	Flashing <input type="text"/> <input type="text"/> <input type="text"/> <input type="text"/> <input type="text"/> (SP VALUE OF PREVIOUS SOAK SEGMENT)	Flashing RDY PROG °C G.S SP
	← <input type="text"/> ▲ <input type="text"/> ▼ <input type="text"/> ENTR <input type="text"/>	Flashing <input type="text"/> <input type="text"/> <input type="text"/> <input type="text"/> <input type="text"/>	Flashing RDY PROG MIN G.S TM
	6 5 0		

	<input type="checkbox"/> ← <input type="checkbox"/> ▲ <input type="checkbox"/> ▼ <input type="checkbox"/> ENTR 2 0	<input type="text" value="2"/> <input type="text" value="0"/> <input type="text" value="0"/>	<input type="checkbox"/> RDY <input type="checkbox"/> PROG <input type="checkbox"/> MIN <input type="checkbox"/> G.S <input type="checkbox"/> TM
SEG		<input type="text" value="0"/> <input type="text" value="5"/> <input type="text" value=""/> <input type="text" value=""/> <input type="text" value=""/> <input type="text" value=""/> (NUMBER OF REMAINING BYTES)	<input type="checkbox"/> RDY <input type="checkbox"/> PROG <input type="checkbox"/> MIN
SOAK RAMP		Flashing <input type="text" value=""/> <input type="text" value=""/> <input type="text" value="0"/> <input type="text" value="0"/>	<input type="checkbox"/> RDY <input type="checkbox"/> PROG <input type="checkbox"/> MIN <input type="checkbox"/> °C <input type="checkbox"/> SP <input type="checkbox"/> TM
	<input type="checkbox"/> ← <input type="checkbox"/> ▲ <input type="checkbox"/> ▼ <input type="checkbox"/> ENTR 8 0 0	<input type="text" value="1"/> <input type="text" value="2"/> <input type="text" value="5"/>	<input type="checkbox"/> RDY <input type="checkbox"/> PROG <input type="checkbox"/> MIN <input type="checkbox"/> °C <input type="checkbox"/> SP <input type="checkbox"/> TM
SEG		<input type="text" value="0"/> <input type="text" value="7"/> <input type="text" value=""/> <input type="text" value=""/> <input type="text" value=""/> <input type="text" value=""/> (NUMBER OF REMAINING BYTES)	<input type="checkbox"/> RDY <input type="checkbox"/> PROG <input type="checkbox"/> MIN
G.SOAK		Flashing <input type="text" value=""/> <input type="text" value="5"/> <input type="text" value="5"/> <input type="text" value="0"/> (SP VALUE OF PREVIOUS SOAK SEGMENT)	<input type="checkbox"/> RDY <input type="checkbox"/> PROG <input type="checkbox"/> °C <input type="checkbox"/> G.S <input type="checkbox"/> SP
	<input type="checkbox"/> ← <input type="checkbox"/> ▲ <input type="checkbox"/> ▼ <input type="checkbox"/> ENTR 3 0	Flashing <input type="text" value=""/> <input type="text" value=""/> <input type="text" value="0"/> <input type="text" value="0"/>	<input type="checkbox"/> RDY <input type="checkbox"/> PROG <input type="checkbox"/> MIN <input type="checkbox"/> G.S <input type="checkbox"/> TM
	<input type="checkbox"/> ← <input type="checkbox"/> ▲ <input type="checkbox"/> ▼ <input type="checkbox"/> ENTR 2 5	<input type="text" value="3"/> <input type="text" value="0"/> <input type="text" value="0"/>	<input type="checkbox"/> RDY <input type="checkbox"/> PROG <input type="checkbox"/> MIN <input type="checkbox"/> G.S <input type="checkbox"/> TM
SEG		<input type="text" value="0"/> <input type="text" value="8"/> <input type="text" value=""/> <input type="text" value=""/> <input type="text" value=""/> <input type="text" value=""/> (NUMBER OF REMAINING BYTES)	<input type="checkbox"/> RDY <input type="checkbox"/> PROG <input type="checkbox"/> MIN
SOAK RAMP		Flashing <input type="text" value=""/> <input type="text" value=""/> <input type="text" value="0"/> <input type="text" value="0"/>	<input type="checkbox"/> RDY <input type="checkbox"/> PROG <input type="checkbox"/> °C <input type="checkbox"/> MIN <input type="checkbox"/> SP <input type="checkbox"/> TM
	<input type="checkbox"/> ← <input type="checkbox"/> ▲ <input type="checkbox"/> ▼ <input type="checkbox"/> ENTR 7 0 0	<input type="text" value="2"/> <input type="text" value="5"/> <input type="text" value="0"/>	<input type="checkbox"/> RDY <input type="checkbox"/> PROG <input type="checkbox"/> °C <input type="checkbox"/> MIN <input type="checkbox"/> SP <input type="checkbox"/> TM
SEG		<input type="text" value="0"/> <input type="text" value="9"/> <input type="text" value=""/> <input type="text" value=""/> <input type="text" value=""/> <input type="text" value=""/> (NUMBER OF REMAINING BYTES)	<input type="checkbox"/> RDY <input type="checkbox"/> PROG <input type="checkbox"/> MIN
SOAK RAMP		Flashing <input type="text" value=""/> <input type="text" value="8"/> <input type="text" value="0"/> <input type="text" value="0"/> (SP VALUE OF PREVIOUS SOAK SEGMENT)	<input type="checkbox"/> RDY <input type="checkbox"/> PROG <input type="checkbox"/> °C <input type="checkbox"/> SP
	<input type="checkbox"/> ← <input type="checkbox"/> ▲ <input type="checkbox"/> ▼ <input type="checkbox"/> ENTR 2 0	<input type="text" value=""/> <input type="text" value=""/> <input type="text" value="0"/> <input type="text" value="0"/>	<input type="checkbox"/> RDY <input type="checkbox"/> PROG <input type="checkbox"/> MIN <input type="checkbox"/> TM
	<input type="checkbox"/> ← <input type="checkbox"/> ▲ <input type="checkbox"/> ▼ <input type="checkbox"/> ENTR 2 0	<input type="text" value="2"/> <input type="text" value="0"/> <input type="text" value="0"/>	<input type="checkbox"/> RDY <input type="checkbox"/> PROG <input type="checkbox"/> MIN <input type="checkbox"/> TM

6. Cycling

- (1) A maximum of 9999 cycles can be entered.
- (2) Cycle number does not include the initial program pattern.
(Example: When a program pattern is cycled for n times, the cycle number (n-1) is entered.)
- (3) If the cycling pattern is returned to a RAMP segment, cycle 0 must be defined to the RAMP segment for pattern to return.
- (4) Cycling function can be used in the following 2 ways.
 - (a) To repeat a complete program
 - (b) To repeat a portion of a program

(Example 1) To repeat a complete program:

Note: Time event is OFF at the end point of a cycling pattern.

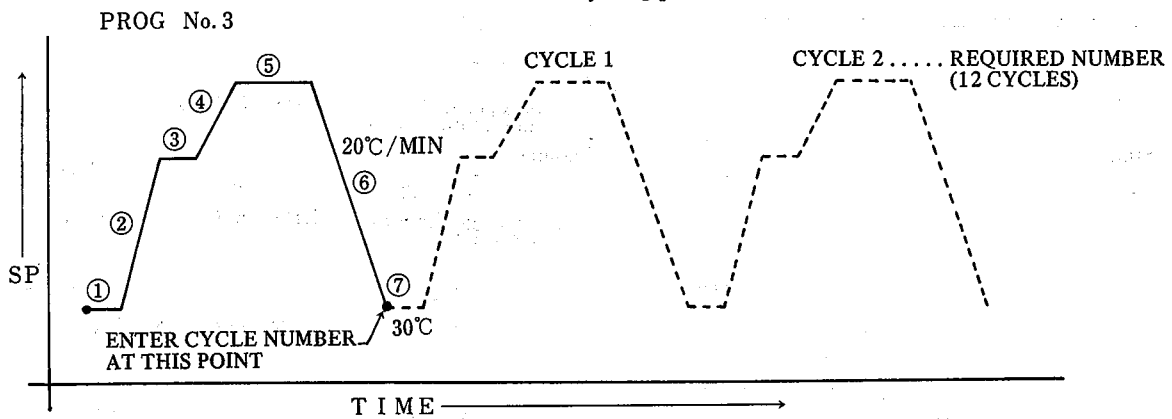

Cycling Setting Procedure

(Example 1)

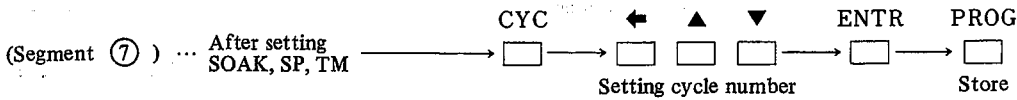

Cycling Setting Procedure: (See program pattern example 1)

FUNCTION	DATA ENTRY	DISPLAY	INDICATOR
SEG		05 (NUMBER OF REMAINING BYTES)	RDY PROG MIN
SOAK RAMP		Flashing 0.0	RDY*PROG °C MIN SP TM
	← ↑ ↓ ENTR 2 0	20.0	RDY PROG °C MIN SP TM
SEG		07 (NUMBER OF REMAINING BYTES)	RDY PROG MIN

廃番

SOAK RAMP <input type="checkbox"/>		Flashing [][][][] (SP VALUE OF PREVIOUS SOAK SEGMENT)	RDY PROG °C SP
	← ▲ ▼ ENTR [] [] [] 3 0	Flashing [][] [] []	RDY PROG MIN TM
	← ▲ ▼ ENTR [] [] [] 0. 0	[][] [] []	RDY PROG MIN TM
CYC <input type="checkbox"/>		Flashing [][][] []	RDY PROG MIN
	← ▲ ▼ ENTR [] [] [] 1 2	[][][] [] []	RDY PROG CYC
PROG <input type="checkbox"/>		[] [] [] [] []	RDY

(Example 2) To repeat a portion of a program:

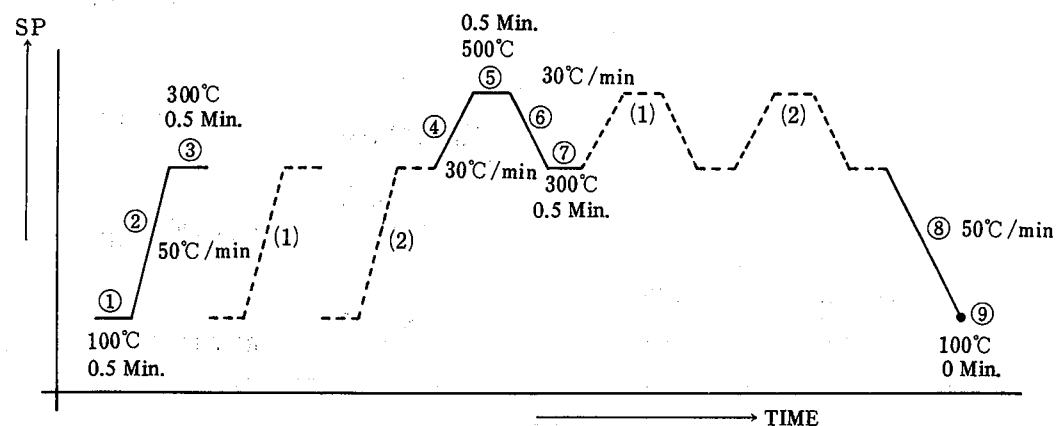

Cycling Setting Procedure

(Example 2)

- (Segment ①) ... After SOAK SP.TM Setting → CYC [] → ← ▲ ▼ Setting of cycle 0 → ENTR [] (Define the starting point of cycling pattern)
- (Segment ③) ... After SOAK SP.TM Setting → CYC [] → ← ▲ ▼ Setting of cycle number → ENTR [] (Repeat a portion of program)
- (Segment ④) ... After SOAK RAMP setting → CYC [] → ← ▲ ▼ Setting of cycle 0 → ENTR [] (Define again the starting point)
- (Segment ⑦) ... After SOAK SP.TM setting → CYC [] → ← ▲ ▼ Setting of cycle number → ENTR [] (Repeat the portion of program from ④ to segment ⑦.)

Cycling Setting Procedure: (See program pattern example 2)

FUNCTION	DATA ENTRY	DISPLAY	INDICATOR
(For entry of the program No., refer to the Chapter SETTING PROGRAM PATTERN).			
SEG <input type="checkbox"/>		<input type="text" value="01"/> (NUMBER OF REMAINING BYTES)	<input type="checkbox"/> RDY <input type="checkbox"/> PROG <input type="checkbox"/> MIN
SOAK RAMP <input type="checkbox"/>		Flashing <input type="text" value="0000"/>	<input type="checkbox"/> RDY <input type="checkbox"/> PROG <input type="checkbox"/> °C <input type="checkbox"/> SP
	← ▲ ▼ ENTR <input type="text" value="1"/> <input type="text" value="0"/> <input type="text" value="0"/> <input type="checkbox"/>	Flashing <input type="text" value="0000"/>	<input type="checkbox"/> RDY <input type="checkbox"/> PROG <input type="checkbox"/> MIN <input type="checkbox"/> TM
	← ▲ ▼ ENTR <input type="text" value="0."/> <input type="text" value="5"/> <input type="checkbox"/>	<input type="text" value="0.5"/>	<input type="checkbox"/> RDY <input type="checkbox"/> PROG <input type="checkbox"/> MIN <input type="checkbox"/> TM
CYC <input type="checkbox"/>		Flashing <input type="text" value="0000"/>	<input type="checkbox"/> RDY <input type="checkbox"/> PROG <input type="checkbox"/> CYC
	ENTR <input type="checkbox"/>	<input type="text" value="0000"/>	<input type="checkbox"/> RDY <input type="checkbox"/> PROG <input type="checkbox"/> MIN <input type="checkbox"/> °C
SEG <input type="checkbox"/>		<input type="text" value="02"/> (NUMBER OF REMAINING BYTES)	<input type="checkbox"/> RDY <input type="checkbox"/> PROG <input type="checkbox"/> MIN <input type="checkbox"/> °C
SOAK RAMP <input type="checkbox"/>		Flashing <input type="text" value="0000"/>	<input type="checkbox"/> RDY <input type="checkbox"/> PROG <input type="checkbox"/> MIN <input type="checkbox"/> °C <input type="checkbox"/> SP <input type="checkbox"/> TM
	← ▲ ▼ ENTR <input type="text" value="5"/> <input type="text" value="0"/> <input type="checkbox"/>	<input type="text" value="5000"/>	<input type="checkbox"/> RDY <input type="checkbox"/> PROG <input type="checkbox"/> MIN <input type="checkbox"/> °C <input type="checkbox"/> SP <input type="checkbox"/> TM
SEG <input type="checkbox"/>		<input type="text" value="03"/> (NUMBER OF REMAINING BYTES)	<input type="checkbox"/> RDY <input type="checkbox"/> PROG <input type="checkbox"/> MIN
SOAK RAMP <input type="checkbox"/>		Flashing <input type="text" value="1000"/> (SP VALUE OF PREVIOUS SOAK SEGMENT)	<input type="checkbox"/> RDY <input type="checkbox"/> PROG <input type="checkbox"/> °C <input type="checkbox"/> SP
	← ▲ ▼ ENTR <input type="text" value="3"/> <input type="text" value="0"/> <input type="text" value="0"/> <input type="checkbox"/>	<input type="text" value="0000"/>	<input type="checkbox"/> RDY <input type="checkbox"/> PROG <input type="checkbox"/> MIN <input type="checkbox"/> TM
	← ▲ ▼ ENTR <input type="text" value="0."/> <input type="text" value="5"/> <input type="checkbox"/>	<input type="text" value="0.5"/>	<input type="checkbox"/> RDY <input type="checkbox"/> PROG <input type="checkbox"/> MIN <input type="checkbox"/> TM
CYC <input type="checkbox"/>		Flashing <input type="text" value="0000"/>	<input type="checkbox"/> RDY <input type="checkbox"/> PROG <input type="checkbox"/> CYC
	← ▲ ▼ ENTR <input type="text" value="2"/> <input type="checkbox"/> <input type="checkbox"/> <input type="checkbox"/>	<input type="text" value="0002"/>	<input type="checkbox"/> RDY <input type="checkbox"/> PROG <input type="checkbox"/> CYC

磨番

SEG <input type="checkbox"/>		04. <input type="checkbox"/> <input type="checkbox"/> <input type="checkbox"/> <input type="checkbox"/> (NUMBER OF REMAINING BYTES)	<input type="checkbox"/> <input type="checkbox"/> <input type="checkbox"/>
SOAK RAMP <input type="checkbox"/>		Flashing <input type="checkbox"/> <input type="checkbox"/> <input type="checkbox"/> <input type="checkbox"/> 0.0	Flashing <input type="checkbox"/> <input type="checkbox"/> <input type="checkbox"/> <input type="checkbox"/> <input type="checkbox"/> <input type="checkbox"/> RDY PROG MIN °C SP TM
	← <input type="checkbox"/> ▲ <input type="checkbox"/> ▼ <input type="checkbox"/> ENTR <input type="checkbox"/> 3 0	<input type="checkbox"/> <input type="checkbox"/> <input type="checkbox"/> <input type="checkbox"/> 300	<input type="checkbox"/> <input type="checkbox"/> <input type="checkbox"/> <input type="checkbox"/> <input type="checkbox"/> <input type="checkbox"/> RDY PROG MIN °C SP TM
CYC <input type="checkbox"/>		Flashing <input type="checkbox"/> <input type="checkbox"/> <input type="checkbox"/> <input type="checkbox"/> 0	Flashing <input type="checkbox"/> <input type="checkbox"/> <input type="checkbox"/> RDY PROG CYC
	← <input type="checkbox"/> ▲ <input type="checkbox"/> ▼ <input type="checkbox"/> ENTR <input type="checkbox"/> 0	<input type="checkbox"/> <input type="checkbox"/> <input type="checkbox"/> <input type="checkbox"/> 0	<input type="checkbox"/> <input type="checkbox"/> <input type="checkbox"/> <input type="checkbox"/> RDY PROG CYC
SEG <input type="checkbox"/>		05. <input type="checkbox"/> <input type="checkbox"/> <input type="checkbox"/> <input type="checkbox"/> (NUMBER OF REMAINING BYTES)	<input type="checkbox"/> <input type="checkbox"/> <input type="checkbox"/>
SOAK RAMP <input type="checkbox"/>		Flashing <input type="checkbox"/> <input type="checkbox"/> <input type="checkbox"/> <input type="checkbox"/> 300 (SP VALUE OF PREVIOUS SOAK SEGMENT)	Flashing <input type="checkbox"/> <input type="checkbox"/> <input type="checkbox"/> <input type="checkbox"/> RDY PROG °C SP
	← <input type="checkbox"/> ▲ <input type="checkbox"/> ▼ <input type="checkbox"/> ENTR <input type="checkbox"/> 5 0 0	Flashing <input type="checkbox"/> <input type="checkbox"/> <input type="checkbox"/> <input type="checkbox"/> 0.0	Flashing <input type="checkbox"/> <input type="checkbox"/> <input type="checkbox"/> <input type="checkbox"/> RDY PROG MIN TM
	← <input type="checkbox"/> ▲ <input type="checkbox"/> ▼ <input type="checkbox"/> ENTR <input type="checkbox"/> 0. 5	<input type="checkbox"/> <input type="checkbox"/> <input type="checkbox"/> <input type="checkbox"/> 0.5	<input type="checkbox"/> <input type="checkbox"/> <input type="checkbox"/> <input type="checkbox"/> RDY PROG MIN TM
SEG <input type="checkbox"/>		06. <input type="checkbox"/> <input type="checkbox"/> <input type="checkbox"/> <input type="checkbox"/> (NUMBER OF REMAINING BYTES)	<input type="checkbox"/> <input type="checkbox"/> <input type="checkbox"/>
SOAK RAMP <input type="checkbox"/>		Flashing <input type="checkbox"/> <input type="checkbox"/> <input type="checkbox"/> <input type="checkbox"/> 0.0	Flashing <input type="checkbox"/> <input type="checkbox"/> <input type="checkbox"/> <input type="checkbox"/> <input type="checkbox"/> <input type="checkbox"/> RDY PROG MIN °C SP TM
	← <input type="checkbox"/> ▲ <input type="checkbox"/> ▼ <input type="checkbox"/> ENTR <input type="checkbox"/> 3 0	<input type="checkbox"/> <input type="checkbox"/> <input type="checkbox"/> <input type="checkbox"/> 300	<input type="checkbox"/> <input type="checkbox"/> <input type="checkbox"/> <input type="checkbox"/> <input type="checkbox"/> <input type="checkbox"/> RDY PROG MIN °C SP TM
SEG <input type="checkbox"/>		07. <input type="checkbox"/> <input type="checkbox"/> <input type="checkbox"/> <input type="checkbox"/> (NUMBER OF REMAINING BYTES)	<input type="checkbox"/> <input type="checkbox"/> <input type="checkbox"/>
SOAK RAMP <input type="checkbox"/>		Flashing <input type="checkbox"/> <input type="checkbox"/> <input type="checkbox"/> <input type="checkbox"/> 500 (SP VALUE OF PREVIOUS SOAK SEGMENT)	Flashing <input type="checkbox"/> <input type="checkbox"/> <input type="checkbox"/> <input type="checkbox"/> RDY PROG °C SP
	← <input type="checkbox"/> ▲ <input type="checkbox"/> ▼ <input type="checkbox"/> ENTR <input type="checkbox"/> 3 0 0	Flashing <input type="checkbox"/> <input type="checkbox"/> <input type="checkbox"/> <input type="checkbox"/> 0.0	Flashing <input type="checkbox"/> <input type="checkbox"/> <input type="checkbox"/> <input type="checkbox"/> RDY PROG MIN TM
	← <input type="checkbox"/> ▲ <input type="checkbox"/> ▼ <input type="checkbox"/> ENTR <input type="checkbox"/> 0. 5	<input type="checkbox"/> <input type="checkbox"/> <input type="checkbox"/> <input type="checkbox"/> 0.5	<input type="checkbox"/> <input type="checkbox"/> <input type="checkbox"/> <input type="checkbox"/> RDY PROG MIN TM
CYC <input type="checkbox"/>		Flashing <input type="checkbox"/> <input type="checkbox"/> <input type="checkbox"/> <input type="checkbox"/> 0	Flashing <input type="checkbox"/> <input type="checkbox"/> <input type="checkbox"/> RDY PROG CYC

廃番

<p>← ▲ ▼ <input type="text"/> <input type="text"/> <input type="text"/> 2</p> <p>ENTR <input type="text"/></p>	<p><input type="text"/><input type="text"/><input type="text"/><input type="text"/> 2</p>	<p>○ ○ ○ RDY PROG CYC</p>
<p>SEG <input type="text"/></p>	<p>08. <input type="text"/><input type="text"/><input type="text"/><input type="text"/> 300 (NUMBER OF REMAINING BYTES)</p>	<p>○ ○ ○ RDY PROG MIN</p>
<p>SOAK RAMP <input type="text"/></p>	<p>Flashing <input type="text"/><input type="text"/><input type="text"/><input type="text"/> 0.0</p>	<p>○ ○ ○ ○ ○ RDY PROG MIN °C SP TM</p>
<p>← ▲ ▼ <input type="text"/> <input type="text"/> <input type="text"/> 5 0</p> <p>ENTR <input type="text"/></p>	<p><input type="text"/><input type="text"/><input type="text"/><input type="text"/> 50.0</p>	<p>○ ○ ○ ○ ○ RDY PROG MIN °C SP TM</p>
<p>SEG <input type="text"/></p>	<p>09. <input type="text"/><input type="text"/><input type="text"/><input type="text"/> (NUMBER OF REMAINING BYTES)</p>	<p>○ ○ ○ RDY PROG MIN</p>
<p>SOAK RAMP <input type="text"/></p>	<p>Flashing <input type="text"/><input type="text"/><input type="text"/><input type="text"/> (SP VALUE OF PREVIOUS SOAK SEGMENT)</p>	<p>○ ○ ○ ○ RDY PROG °C SP</p>
<p>← ▲ ▼ <input type="text"/> <input type="text"/> <input type="text"/> 1 0 0</p> <p>ENTR <input type="text"/></p>	<p>Flashing <input type="text"/><input type="text"/><input type="text"/><input type="text"/> 0.0</p>	<p>○ ○ ○ ○ RDY PROG MIN TM</p>
<p>← ▲ ▼ <input type="text"/> <input type="text"/> <input type="text"/></p> <p>ENTR <input type="text"/></p>	<p><input type="text"/><input type="text"/><input type="text"/><input type="text"/> 0.0</p>	<p>○ ○ ○ ○ RDY PROG MIN TM</p>
<p>PROG <input type="text"/></p>	<p>01. <input type="text"/><input type="text"/><input type="text"/><input type="text"/></p>	<p>○ RDY</p>

7. Programmable PID

- (1) For 9 program patterns, one or 3 groups of PID values can be selected by an internal DIP switch.
- (2) If 3 groups are selected, the total 3 groups of PID-1, PID-2, and PID-3 (P, I, and D values to be set are handled as one group) can be set for each program No. or each segment No.
- (3) If a PID group No. is not defined during programming, automatically the PID-1 group is entered and the controlling is made by P, I, and D values of PID-1 group. (If PID-1 group is selected for a starting segment, the setting of PID-1 is not necessary even if one or 3 groups of PID are selected.)
- (4) If 3 groups of PID are selected, the PID group No. entered at the first segment is effective to the segment for which the next different PID group No. is defined (for each program No.).

(Example)

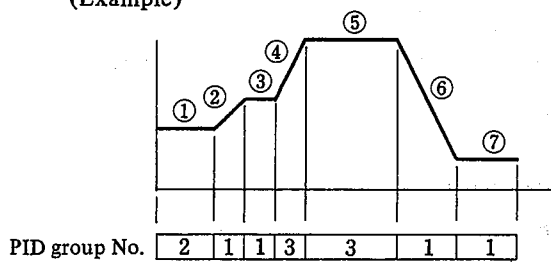

- Segment ① : Set PID-2 group.
- Segment ② : Set PID-1 group.
- Segment ③ : Setting is not necessary.
- Segment ④ : Set PID-3 group.
- Segment ⑤ : Setting is not necessary.
- Segment ⑥ : Set PID-1 group.
- Segment ⑦ : Setting is not necessary.

- (5) Program No. is defined in the programming mode. Setting of PID values are made in **READY** or **RUN/HOLD** mode. For PID value setting, refer to the Chapter **SETTING AND VERIFICATION OF CONTROL CONSTANTS**.
- (6) If 3 groups of PID are selected, the group No. of the entered PID can be changed by ▲ or ▼ key in **VERIFY** mode.
- (7) P, I, and D values for each PID group are commonly applied to all program numbers or all segments. Therefore, if PID values of a program No. were changed, the PID values of the same PID group No. used for that program No. or other segment are automatically changed to the new values.

8. Programmable Output Limiter

- (1) When 3 groups of PID function are selected by the internal selector switch (SW1), the setting of 3 different output limiting values are possible.

PID-1 group ... Parameter	Σ 0 1	Output limiter No. 1	HIGH
	Σ 0 2	"	LOW
PID-2 group ... Parameter	Σ 0 3	Output limiter No. 2	HIGH
	Σ 0 4	"	LOW
PID-3 group ... Parameter	Σ 0 5	Output limiter No. 3	HIGH
	Σ 0 6	"	LOW

- (2) Each output limiter value can be set in **READY** mode or in **RUN/HOLD** mode. For setting, refer to the Chapter **SETTING AND VERIFICATION OF CONTROL CONSTANTS**

9. Programmable Range

- (1) For 0 to 100% of the linear current or the linear voltage input, range setting can be made corresponding to the measuring range.

Programmable setting range	Parameter to select the decimal point location
-1.799 to 7.999	3
-17.99 to 79.99	2
-179.9 to 799.9	1
-1799 to 7999	0

Selection of the decimal point location must be made before programming and entry of program pattern.

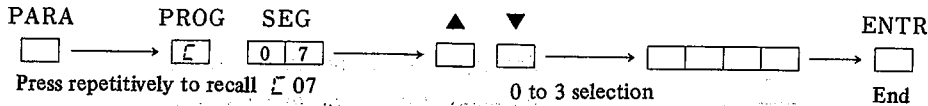

Optional value setting to input 100% value or 0% value must be made before programming and entry of program pattern.

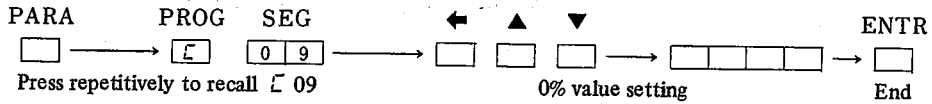
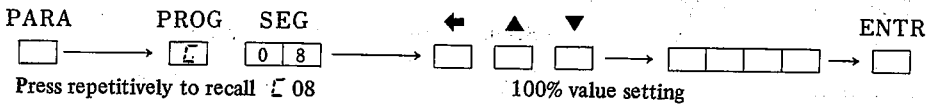

- (2) By the above manipulation, all the SP/PV/DEV values which were entered at program entry are set and displayed in the range scale corresponding to the input range. An input PV value is also displayed in the same range scale.
- (3) The setting of the decimal point location, input 100% and 0% values is common for all program numbers.

10. Setting Cycle Time

The cycle time for time proportional output is set by **PARA** key at 3, 6, 9, 12, ..., or 60 seconds (multiples of 3).

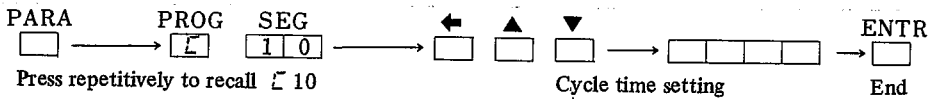

SETTING PROGRAM PATTERN

1. Sample Program

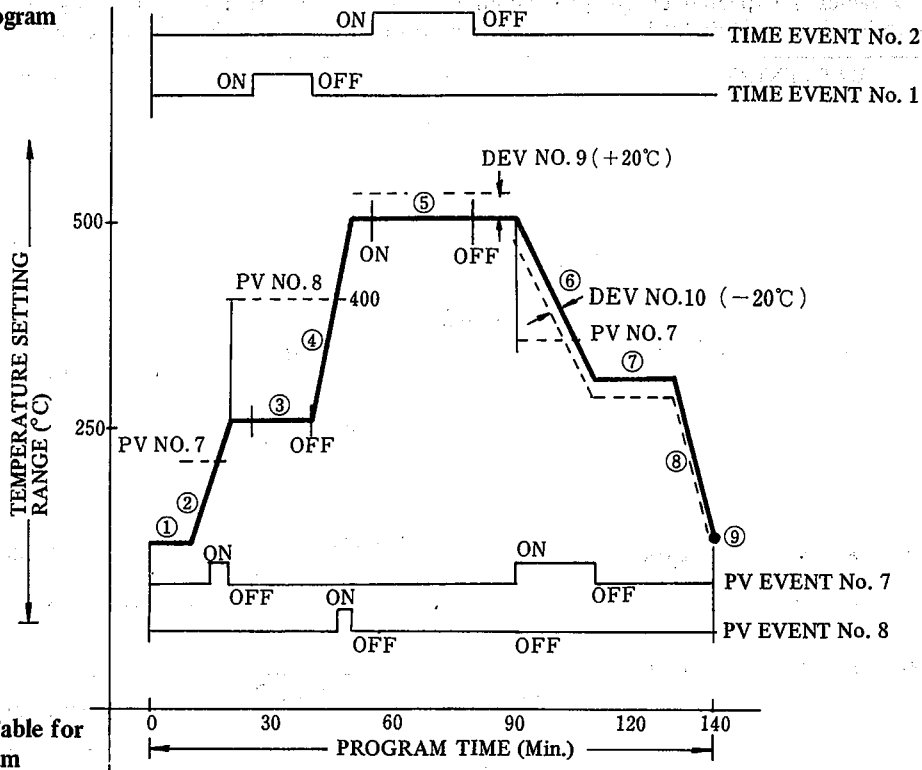

Programming Table for Sample Program

Program No.:	<input type="checkbox"/> PROG	PROG	<u>5</u>						
Time Unit:	<u>MIN</u>		PID Group: No. 1						
Temperature Unit:	<u>°C</u>								
Temperature Range:	0 ~ 600°C								
Program Time;	140 Min.								
SEG	SOAK RAMP (SP)	SOAK RAMP (SOAK DUR)	SOAK RAMP (RAMP)	EVENT	EVENT(No.)	TIME ON	TIME OFF	PV	DEV
1	<u>100</u> °C	<u>10</u> MIN	°C/MIN						
2			<u>15</u>	<u>PV</u>	<u>7</u>			<u>200</u>	
3	<u>250</u>	<u>20</u>		<u>TIME</u>	<u>1</u>	<u>5</u>	<u>20</u>		
				<u>PV</u>	<u>8</u>			<u>400</u>	
4			<u>25</u>						
5	<u>500</u>	<u>40</u>		<u>TIME</u>	<u>2</u>	<u>5</u>	<u>30</u>		
				<u>DEV</u>	<u>9</u>				<u>+20</u>
6			<u>10</u>	<u>DEV</u>	<u>10</u>				<u>-20</u>
				<u>PV</u>	<u>7</u>			<u>350</u>	
7	<u>300</u>	<u>20</u>							
8			<u>20</u>						
9	<u>100</u>	<u>0</u>							

2. Setting Sample Program

Programming is made in the order shown below.

If a change of PID values is expected before programming, it is necessary to press **PID** key and enter PID No. 1 for the pattern in advance. If PID values are not changed for each pattern, this is not necessary.

FUNCTION	DATA ENTRY	DISPLAY	INDICATOR
RESET <input type="checkbox"/>			<input type="radio"/> RDY
PROG <input type="checkbox"/>		PROG 5. SEC 01. <input type="text"/> <input type="text"/> <input type="text"/> <input type="text"/>	
<input type="checkbox"/> ← PROG	(PRESS PROG KEY WITH ← KEY PRESSED)	(NUMBER OF REMAINING BYTES) 1797	<input type="radio"/> RDY <input type="radio"/> PROG <input type="radio"/> MIN
SOAK RAMP <input type="checkbox"/>		Flashing <input type="text"/> <input type="text"/> 0.0	<input type="radio"/> RDY <input type="radio"/> PROG <input type="radio"/> °C <input type="radio"/> SP
	← <input type="text"/> 1 ▲ <input type="text"/> 0 ▼ <input type="text"/> 0 ENTR <input type="checkbox"/>	Flashing <input type="text"/> <input type="text"/> 0.0	<input type="radio"/> RDY <input type="radio"/> PROG <input type="radio"/> MIN <input type="radio"/> TM
	← <input type="text"/> 1 ▲ <input type="text"/> 0 ▼ <input type="text"/> 0 ENTR <input type="checkbox"/>	<input type="text"/> 10.0	<input type="radio"/> RDY <input type="radio"/> PROG <input type="radio"/> MIN <input type="radio"/> TM
SEG <input type="checkbox"/>		(NUMBER OF REMAINING BYTES) 02. <input type="text"/> <input type="text"/> <input type="text"/> <input type="text"/>	<input type="radio"/> RDY <input type="radio"/> PROG <input type="radio"/> MIN
SOAK RAMP <input type="checkbox"/>		Flashing <input type="text"/> <input type="text"/> 0.0	<input type="radio"/> RDY <input type="radio"/> PROG <input type="radio"/> °C <input type="radio"/> MIN <input type="radio"/> SP <input type="radio"/> TM
	← <input type="text"/> 1 ▲ <input type="text"/> 5 ▼ <input type="text"/> 5 ENTR <input type="checkbox"/>	<input type="text"/> 15.0	<input type="radio"/> RDY <input type="radio"/> PROG <input type="radio"/> °C <input type="radio"/> MIN <input type="radio"/> SP <input type="radio"/> TM
EVENT <input type="checkbox"/>		Flashing <input type="text"/> <input type="text"/> <input type="text"/> 1	<input type="radio"/> RDY <input type="radio"/> PROG <input type="radio"/> EV
	▲ <input type="text"/> 7 ENTR <input type="checkbox"/>	(MAXIMUM VALUE OF INSTRUMENT RANGE) 500	<input type="radio"/> RDY <input type="radio"/> PROG <input type="radio"/> EV <input type="radio"/> °C <input type="radio"/> PV(NO.7)
	← <input type="text"/> 2 ▲ <input type="text"/> 0 ▼ <input type="text"/> 0 ENTR <input type="checkbox"/>	Flashing <input type="text"/> 200	<input type="radio"/> RDY <input type="radio"/> PROG <input type="radio"/> EV <input type="radio"/> °C <input type="radio"/> PV(NO.7)
SEG <input type="checkbox"/>		(NUMBER OF REMAINING BYTES) 03. <input type="text"/> <input type="text"/> <input type="text"/> <input type="text"/>	<input type="radio"/> RDY <input type="radio"/> PROG <input type="radio"/> MIN
SOAK RAMP <input type="checkbox"/>		Flashing <input type="text"/> 100	<input type="radio"/> RDY <input type="radio"/> PROG <input type="radio"/> °C <input type="radio"/> SP
	← <input type="text"/> 2 ▲ <input type="text"/> 5 ▼ <input type="text"/> 0 ENTR <input type="checkbox"/>	(SP VALUE OF PREVIOUS SOAK SEGMENT) <input type="text"/> 0.0	<input type="radio"/> RDY <input type="radio"/> PROG <input type="radio"/> MIN <input type="radio"/> TM

FUNCTION	DATA ENTRY	DISPLAY	INDICATOR
EVENT			
EVENT			
EVENT			
SEG			
SOAK RAMP			

FUNCTION	DATA ENTRY	DISPLAY	INDICATOR
SEG <input type="checkbox"/>		(NUMBER OF REMAINING BYTES) 05	RDY PROG MIN
SOAK RAMP <input type="checkbox"/>		Flashing 250 (SP VALUE OF PREVIOUS SOAK SEGMENT)	RDY PROG °C SP
	← <input type="checkbox"/> ▲ <input type="checkbox"/> ▼ <input type="checkbox"/> ENTR <input type="checkbox"/> 5 0 0	Flashing 0.0	RDY PROG MIN TM
	← <input type="checkbox"/> ▲ <input type="checkbox"/> ▼ <input type="checkbox"/> ENTR <input type="checkbox"/> 4 0 0	40.0	RDY PROG MIN TM
EVENT <input type="checkbox"/>		Flashing 1	RDY PROG EV
	▲ <input type="checkbox"/> ENTR <input type="checkbox"/> 2	Flashing 0.0	RDY PROG EV MIN TM TIME NO.2
	← <input type="checkbox"/> ▲ <input type="checkbox"/> ENTR <input type="checkbox"/> 5	Flashing 0.0	RDY PROG EV MIN TM TIME NO.2
	← <input type="checkbox"/> ▲ <input type="checkbox"/> ENTR <input type="checkbox"/> 3 0	30.0	RDY PROG EV MIN TM TIME NO.2
EVENT <input type="checkbox"/>		Flashing 1	RDY PROG EV
	← <input type="checkbox"/> ▲ <input type="checkbox"/> ▼ <input type="checkbox"/> ENTR <input type="checkbox"/> 9	(MAXIMUM VALUE OF INSTRUMENT RANGE) Flashing	RDY PROG EV °C DEV NO.9
	← <input type="checkbox"/> ▲ <input type="checkbox"/> ▼ <input type="checkbox"/> ENTR <input type="checkbox"/> 2 0 0	20.0	RDY PROG EV °C DEV NO.9
EVENT <input type="checkbox"/>		Flashing 1	RDY PROG EV
	← <input type="checkbox"/> ▲ <input type="checkbox"/> ▼ <input type="checkbox"/> ENTR <input type="checkbox"/> 8	Flashing (UPPER LIMIT VALUE OF RANGE)	RDY PROG EV °C PV8
	ENTR <input type="checkbox"/>	(UPPER LIMIT VALUE OF RANGE)	RDY PROG EV °C PV8

FUNCTION	DATA ENTRY	DISPLAY	INDICATOR
SEG <input type="checkbox"/>		(NUMBER OF REMAINING BYTES) 05	<input type="checkbox"/> RDY <input type="checkbox"/> PROG <input type="checkbox"/> MIN
SOAK RAMP <input type="checkbox"/>		Flashing 0.0	<input type="checkbox"/> RDY <input type="checkbox"/> PROG <input type="checkbox"/> MIN <input type="checkbox"/> °C <input type="checkbox"/> SP <input type="checkbox"/> TM
	← <input type="checkbox"/> <input type="checkbox"/> <input type="checkbox"/> <input type="checkbox"/> ENTR 1 0 0	10.0	<input type="checkbox"/> RDY <input type="checkbox"/> PROG <input type="checkbox"/> MIN <input type="checkbox"/> °C <input type="checkbox"/> SP <input type="checkbox"/> TM
EVENT <input type="checkbox"/>		Flashing 1	<input type="checkbox"/> RDY <input type="checkbox"/> PROG <input type="checkbox"/> EV
	← <input type="checkbox"/> <input type="checkbox"/> <input type="checkbox"/> <input type="checkbox"/> ENTR 1 0	(MAXIMUM VALUE OF INSTRUMENT RANGE) Flashing	<input type="checkbox"/> RDY <input type="checkbox"/> PROG <input type="checkbox"/> EV <input type="checkbox"/> °C <input type="checkbox"/> DEV NO.10
	← <input type="checkbox"/> <input type="checkbox"/> <input type="checkbox"/> <input type="checkbox"/> ENTR - 2 0	-20.0	<input type="checkbox"/> RDY <input type="checkbox"/> PROG <input type="checkbox"/> EV <input type="checkbox"/> °C <input type="checkbox"/> DEV NO.10
EVENT <input type="checkbox"/>		Flashing 1	<input type="checkbox"/> RDY <input type="checkbox"/> PROG <input type="checkbox"/> EV
	← <input type="checkbox"/> <input type="checkbox"/> <input type="checkbox"/> <input type="checkbox"/> ENTR 7	(MAXIMUM VALUE OF INSTRUMENT RANGE) Flashing	<input type="checkbox"/> RDY <input type="checkbox"/> PROG <input type="checkbox"/> EV <input type="checkbox"/> °C <input type="checkbox"/> PV NO.7
	← <input type="checkbox"/> <input type="checkbox"/> <input type="checkbox"/> <input type="checkbox"/> ENTR 3 5 0	35.0	<input type="checkbox"/> RDY <input type="checkbox"/> PROG <input type="checkbox"/> EV <input type="checkbox"/> °C <input type="checkbox"/> PV NO.7
EVENT <input type="checkbox"/>		Flashing 1	<input type="checkbox"/> RDY <input type="checkbox"/> PROG <input type="checkbox"/> EV
	← <input type="checkbox"/> <input type="checkbox"/> <input type="checkbox"/> <input type="checkbox"/> ENTR 9	(UPPER LIMIT VALUE OF RANGE) Flashing	<input type="checkbox"/> RDY <input type="checkbox"/> PROG <input type="checkbox"/> EV <input type="checkbox"/> °C <input type="checkbox"/> DEV NO.9
	<input type="checkbox"/> ENTR	(UPPER LIMIT VALUE OF RANGE)	<input type="checkbox"/> RDY <input type="checkbox"/> PROG <input type="checkbox"/> EV <input type="checkbox"/> °C <input type="checkbox"/> DEV NO.9
SEG <input type="checkbox"/>		(NUMBER OF REMAINING BYTES) 07	<input type="checkbox"/> RDY <input type="checkbox"/> PROG <input type="checkbox"/> MIN
SOAK RAMP <input type="checkbox"/>		Flashing 50.0	<input type="checkbox"/> RDY <input type="checkbox"/> PROG <input type="checkbox"/> °C <input type="checkbox"/> SP
	← <input type="checkbox"/> <input type="checkbox"/> <input type="checkbox"/> <input type="checkbox"/> ENTR 3 0 0	(SP VALUE OF PREVIOUS SOAK SEGMENT) 0.0	<input type="checkbox"/> RDY <input type="checkbox"/> PROG <input type="checkbox"/> MIN <input type="checkbox"/> TM
	← <input type="checkbox"/> <input type="checkbox"/> <input type="checkbox"/> <input type="checkbox"/> ENTR 2 0	20.0	<input type="checkbox"/> RDY <input type="checkbox"/> PROG <input type="checkbox"/> MIN <input type="checkbox"/> TM

FUNCTION	DATA ENTRY	DISPLAY	INDICATOR
EVENT <input type="checkbox"/>		Flashing [][][][]	Flashing RDY PROG EV
	← [] [] [] 7 ENTR <input type="checkbox"/>	Flashing [][][][] (UPPER LIMIT VALUE OF RANGE)	RDY PROG EV °C PV7
	ENTR <input type="checkbox"/>	[][][][] (UPPER LIMIT VALUE OF RANGE)	RDY PROG EV °C PV7
SEG <input type="checkbox"/>		(NUMBER OF REMAINING BYTES) 08 [][][]	RDY PROG MIN
SOAK RAMP <input type="checkbox"/>		Flashing [][]0.0	Flashing RDY PROG °C MIN SP TM
	← [] [] [] 2 0 0 ENTR <input type="checkbox"/>	[]20.0	RDY PROG °C MIN SP TM
SEG <input type="checkbox"/>		(NUMBER OF REMAINING BYTES) 03 [][][]	RDY PROG MIN
SOAK RAMP <input type="checkbox"/>		Flashing []30.0 (SP VALUE OF PREVIOUS SOAK SEGMENT)	Flashing RDY PROG MIN SP
	← [] [] [] 1 0 0 ENTR <input type="checkbox"/>	[][]0.0	Flashing RDY PROG MIN TM
	ENTR <input type="checkbox"/>	[][]0.0	RDY PROG MIN TM
PROG <input type="checkbox"/>		PROG 5 SEG 01 [][][]	RDY

3. Deletion of Segment during Programming

By pressing **SEG** key with **CLR** key pressed, the program data (segment No. indicated in SEG display) entered can be deleted during programming.

By repeating the same key manipulation, the data in each segment is deleted and the segment No. is returned to the former segment No. in order.

If it is necessary to change the data during programming, this segment deletion function is utilized. By doing so, change during programming will be possible without reentering all the data of a program. The numerical data such as SP value, soak time, or RAMP value can be changed in VERIFY mode even after programming.

4. Verifying Content of Sample Program.

DCP511 "VERIFY" mode is to verify the contents of an entered program. The verification of the sample program shown in Item 1 is made in the following manner:

FUNCTION	DISPLAY	INDICATOR
RESET <input type="checkbox"/>		<input type="checkbox"/> RDY
PROG <input type="checkbox"/>	PROG 5. SEG 01. <input type="checkbox"/> <input type="checkbox"/> <input type="checkbox"/> <input type="checkbox"/>	<input type="checkbox"/> RDY
VRFY <input type="checkbox"/>	<input type="checkbox"/> <input type="checkbox"/> <input type="checkbox"/> <input type="checkbox"/>	<input type="checkbox"/> RDY <input type="checkbox"/> VRFY <input type="checkbox"/> MIN
VRFY <input type="checkbox"/>	<input type="checkbox"/> <input type="checkbox"/> 100	<input type="checkbox"/> RDY <input type="checkbox"/> VRFY <input type="checkbox"/> °C <input type="checkbox"/> SP Flashing
VRFY <input type="checkbox"/>	<input type="checkbox"/> <input type="checkbox"/> 100	<input type="checkbox"/> RDY <input type="checkbox"/> VRFY <input type="checkbox"/> MIN <input type="checkbox"/> TM Flashing
VRFY <input type="checkbox"/>	SEG 02. <input type="checkbox"/> <input type="checkbox"/> 150	<input type="checkbox"/> RDY <input type="checkbox"/> VRFY <input type="checkbox"/> MIN <input type="checkbox"/> °C <input type="checkbox"/> SP <input type="checkbox"/> TM Flashing
VRFY <input type="checkbox"/>	<input type="checkbox"/> <input type="checkbox"/> 200	<input type="checkbox"/> RDY <input type="checkbox"/> VRFY <input type="checkbox"/> EV <input type="checkbox"/> °C <input type="checkbox"/> PV NO.7 Flashing
VRFY <input type="checkbox"/>	SEG 03. <input type="checkbox"/> <input type="checkbox"/> 250	<input type="checkbox"/> RDY <input type="checkbox"/> VRFY <input type="checkbox"/> °C <input type="checkbox"/> SP Flashing
VRFY <input type="checkbox"/>	<input type="checkbox"/> <input type="checkbox"/> 200	<input type="checkbox"/> RDY <input type="checkbox"/> VRFY <input type="checkbox"/> MIN <input type="checkbox"/> TM Flashing
VRFY <input type="checkbox"/>	<input type="checkbox"/> <input type="checkbox"/> 50	<input type="checkbox"/> RDY <input type="checkbox"/> VRFY <input type="checkbox"/> EV <input type="checkbox"/> MIN <input type="checkbox"/> TM <input type="checkbox"/> TIME NO.1 Flashing
VRFY <input type="checkbox"/>	<input type="checkbox"/> <input type="checkbox"/> 200	<input type="checkbox"/> RDY <input type="checkbox"/> VRFY <input type="checkbox"/> EV <input type="checkbox"/> MIN <input type="checkbox"/> TM <input type="checkbox"/> TIME NO.1 Flashing
VRFY <input type="checkbox"/>	<input type="checkbox"/> <input type="checkbox"/> 400	<input type="checkbox"/> RDY <input type="checkbox"/> VRFY <input type="checkbox"/> EV <input type="checkbox"/> °C <input type="checkbox"/> PV NO.8 Flashing
VRFY <input type="checkbox"/>	(UPPER LIMIT VALUE OF INSTRUMENT RANGE) <input type="checkbox"/> <input type="checkbox"/> 500	<input type="checkbox"/> RDY <input type="checkbox"/> VRFY <input type="checkbox"/> EV <input type="checkbox"/> °C <input type="checkbox"/> PV NO.7 Flashing

磨 番

VRFY

SEG

04

25.0

RDY VRFY °C MIN SP TM
Flashing

VRFY

SEG

05

500

RDY VRFY °C SP
Flashing

VRFY

40.0

RDY VRFY MIN TM
Flashing

VRFY

5.0

RDY VRFY MIN EV TM TIME NO.2
Flashing

VRFY

30.0

RDY VRFY MIN EV TM TIME NO.2
Flashing

VRFY

20.0

RDY VRFY °C EV DEV NO.9
Flashing

VRFY

(UPPER LIMIT VALUE OF INSTRUMENT RANGE)

600

RDY VRFY °C EV DEV NO.8
Flashing

VRFY

SEG

06

100

RDY VRFY °C MIN SP TM
Flashing

VRFY

-20.0

RDY VRFY °C EV DEV NO.10
Flashing

VRFY

350

RDY VRFY °C EV PV NO.7
Flashing

VRFY

(UPPER LIMIT VALUE OF INSTRUMENT RANGE)

RDY VRFY °C EV DEV NO.9
Flashing

VRFY

SEG

07

300

RDY VRFY °C SP
Flashing

VRFY

20.0

RDY VRFY MIN TM
Flashing

VRFY

(UPPER LIMIT VALUE OF INSTRUMENT RANGE)

500

RDY VRFY °C EV PV NO.7
Flashing

VRFY

SEG

08

20.0

RDY VRFY MIN °C SP TM
Flashing

VRFY

SEG

09

100

RDY VRFY °C SP
Flashing

VRFY

0.0

RDY VRFY MIN TM
Flashing

VRFY

PROG SEG

5

--

RDY VRFY MIN

OPERATION OF PROGRAM

1. Starting Program

A. To start from Segment 1 of the Program Pattern:

- (1) Press $\frac{\text{RESET}}{\square}$ key to place program controller in READY mode. (In RUN mode, press RESET key with \leftarrow key pressed.)
- (2) Press $\frac{\text{PROG}}{\square}$ key to recall the number of the program to be operated.
- (3) Press $\frac{\text{RUN}}{\text{HOLD}} \square$ key to start the program from segment No. 1 in accordance with the stored program pattern.

B. To start from a point other than the first segment:

a. In RUN (operation) mode:

- (1) Press $\frac{\text{RUN}}{\text{HOLD}} \square$ key to hold the program operation.
- (2) Press $\text{SEG} \square$ key repetitively to select the segment to be restarted.
- (3) Press $\frac{\text{RUN}}{\text{HOLD}} \square$ key to restart the program.

b. In READY mode:

- (1) Press $\text{SEG} \square$ key repetitively to select the segment to be restarted.
- (2) Press $\frac{\text{RUN}}{\text{HOLD}} \square$ key to restart the program.

(Example)

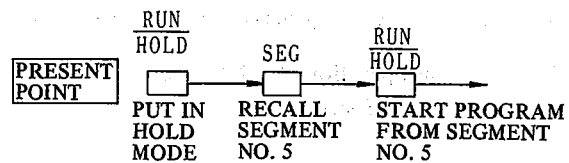
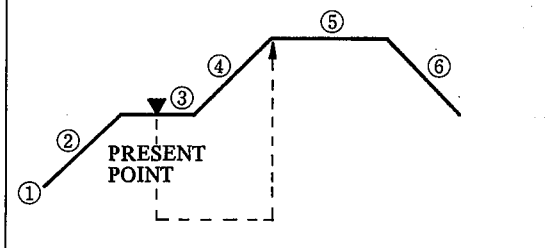

C. To start from PV Value Point in the Program Pattern (Change switch-1 of DIP switch (DIP) to H side (ON).):

- (1) Press $\frac{\text{RESET}}{\square}$ key to place the controller in READY mode. (In RUN mode, press $\frac{\text{RESET}}{\square}$ key with \leftarrow key pressed.)
- (2) Press $\frac{\text{PROG}}{\square}$ key to recall the number of the program to be operated.

- (3) Press $\frac{\text{RUN}}{\text{HOLD}}$ key with key pressed to select automatically the point in the program pattern for which value is equivalent to the PV value at the time, and to hold the program operation. (If there are many equivalent values, the value nearest to the starting point is selected.)
- (4) Press $\frac{\text{RUN}}{\text{HOLD}}$ key to restart the program.

2. Stopping and Restarting a Program from Hold Condition

A. Stopping Program in Progress:

Press $\frac{\text{RUN}}{\text{HOLD}}$ key.

A HOLD LED lights to indicate the program is in HOLD.

Soak time, ramp and event timer are stopped, and the program is held until $\frac{\text{RUN}}{\text{HOLD}}$ key is pressed. (At this time, the process remains under control at the HOLD set point.)

B. Restarting a Program from Hold Condition:

Press $\frac{\text{RUN}}{\text{HOLD}}$ key to restart the program from the HOLD point.

3. Resetting Program.

A. Resetting a Program in Progress to the RDY mode:

(1) Press $\frac{\text{RESET}}{\text{HOLD}}$ key with key pressed.

(2) Press $\frac{\text{RESET}}{\text{HOLD}}$ key again to clear the program No. and segment 1 displayed, and reset the program to the initial READY mode where a program No. is not selected.

It is possible to reset a program to RDY mode from VERIFY or HOLD mode by the same procedure.

When manual operation (MAN) is being conducted, return to the automatic (AUTO) mode first, and then follow the same procedure.

B. Resetting a Program in VERIFY/PROG mode to RDY Mode:



Press $\frac{\text{RESET}}{\text{HOLD}}$ key to clear VERIFY/PRG mode. The unit returns to the RDY mode. (Program is at segment 1 of the selected program.)

4. Auto/Manual Operation

(1) Automatic (AUTO) mode:

This is the mode in which PID computation result is the output variable. RUN or HOLD mode can be selected by $\frac{\text{RUN}}{\text{HOLD}}$ key.

(2) Manual (MAN) mode:

This is the mode in which the input value selected by    keys (not by PID computation result) is the output variables.

Manual operation can be made not only in RUN or HOLD mode but also in READY mode.

(3) When pressing  key alternately (AUTO→MAN→AUTO→MAN→), a balanceless and bumpless transfer is made.

(4) In MAN mode, the output value is automatically displayed in the variable display, and the OUT LED lights.

(5) Output in MAN mode is adjusted within the range between the preset HIGH (upper limit) and LOW (lower limit) output limiter values.

5. Remote Operation

(1) Changing a program pattern, holding (HOLD) a program in progress, resetting a program, and restarting a program can also be done by remote operation (not by the console keys) when the wiring connection of the DCP511 is as shown in Fig. 4.

When operation is switched from READY mode to remote RUN mode, the selected program starts from the segment No. 1

(2) Changing a Program Pattern:

When a program pattern is changed in remote operation, conduct first remote resetting, and re-select the program, and then placing controller in RUN mode.

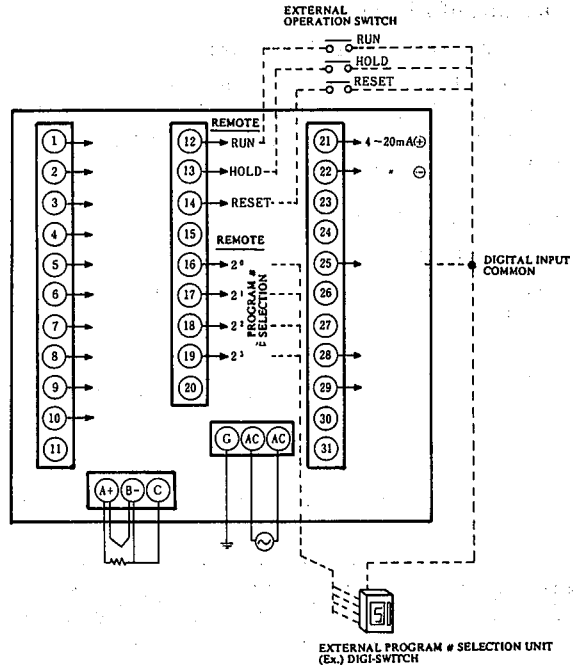
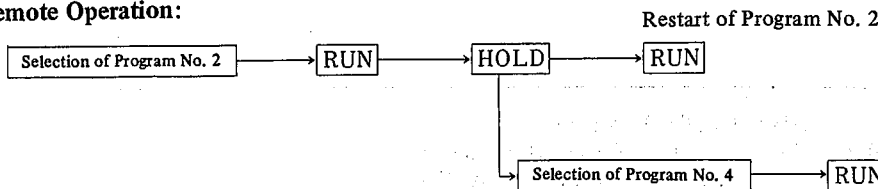
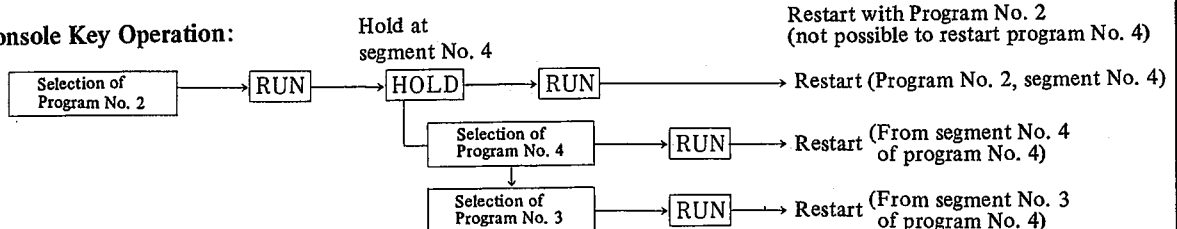

Fig. 4 DCP511 External Wiring Diagram

Remote Operation:



Console Key Operation:



6. Program Editing

Data of a stored program can be edited when the instrument is in RDY or RUN/HOLD mode. Addition of a new function or the segment order change cannot be made without reprogramming.

Data of the segment in a program in progress can be changed in the following manner:

- (1) Press VRFY key repetitively looking at the segment No. until the segment to be changed is displayed. When it is necessary to verify the former segments advance the program No. until the present program No. appears again, and then press VRFY key repetitively.
- (2) When the desired segment is obtained, manipulate ←, ▲ , ▼ keys to change the data.
- (3) Press ENTR key.
- (4) Press DISP key to place instrument in RUN/HOLD condition. When the data are being changed in VRFY mode, the process remains under control at the HOLD set point in RUN mode. However, if the data of the program in progress was changed, not the present data but the content of program memory only is changed, and the changed data will be applied from the next operation.

7. Deletion of Program Pattern

A. Deletion of All Patterns:

- (1) Slide the internal chassis forward.
- (2) When G.R reset switch shown in Photo. 3 is set to the arrow mark position, all the stored pattern data are deleted at once. At this time, the memory switch must have been set to M.E position before setting G.R switch.

B. Deletion of Only One Pattern:

- (1) Put instrument in RDY mode.
- (2) Recall the number of the program to be deleted by pressing PROG key.
- (3) Press PROG key with CLR key pressed.
- (4) For verification, enter the number of the program deleted. Error code E 03 flashes.

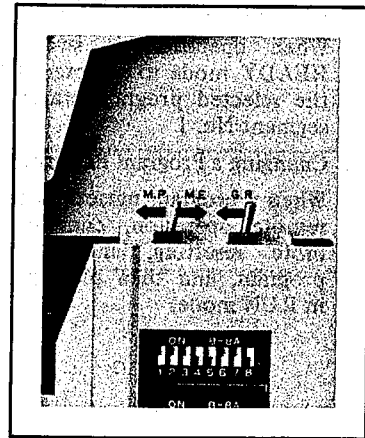

Photo. 3

SETTING AND VERIFICATION OF CONTROL CONSTANTS

Maximum of 3 groups of PID values are selectable to set optimum control constants so that the DCP511 can realize ideal program operation corresponding to the operating conditions and load capacity of the equipment.

1. Setting PID Values

Control Constants: P (Proportional Band): 1 to 1000%
 I (Reset Time): 0, 1 to 1800 sec. (0 means OFF.)
 D (Rate Time): 0, 1 to 600 sec. (0 means OFF.)

Setting Proportional Band:

- (1) Press PID key. PROG P SEG 01 (preset value) are displayed.
- (2) Set the desired proportional band at this time.

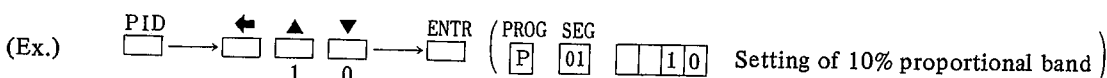

Setting Reset Time:

- (1) Press $\overline{\text{PID}}$ key, $\overline{\text{I}}$ $\overline{0}$ $\overline{1}$ $\square\square\square\square$ (preset value) are displayed.
 (2) Set the desired reset time (sec.) at this time.

(Ex.) $\overline{\text{PID}}$ \square \leftarrow $\overline{\text{I}}$ $\overline{0}$ $\overline{1}$ $\square\square\square\square$ \rightarrow $\overline{\text{ENTR}}$ ($\overline{\text{I}}$ $\overline{0}$ $\overline{1}$ $\square\square$ $\overline{2}$ $\overline{5}$) Setting of 25 sec. reset time

Setting Rate Time:

- (1) Press $\overline{\text{PID}}$ key. $\overline{\text{d}}$ $\overline{0}$ $\overline{1}$ $\square\square\square\square$ (preset value) are displayed.
 (2) Set the desired rate time (sec.) at this time.

By pressing $\overline{\text{PID}}$ key repetitively, the order of P, I, and D is changed as P01→I01→d01→P02→I02→d02→P03→I03→d03 if 3 kinds of PID groups are selected by the internal DIP switch.

(Note: The value of 100% has been entered only for P01, P02 & P03 previously. Other PID values are all 0.)

2. Setting Output Limiter Values

A. Output Limiter Values:

HIGH (Upper limit): -5.0 to 105.0%

LOW (Lower Limit): -5.0 to 105.0%

(Setting must be made as HIGH setting value > LOW setting value.)

B. Setting Output Limiter Values:

- (1) Press $\overline{\text{PARA}}$ key repetitively. $\overline{\text{C}}$ $\overline{0}$ $\overline{1}$ $\square\square\square\square$ (preset value) are displayed.

Set the desired No. 1 HIGH value with $\overline{\leftarrow}$, $\overline{\uparrow}$, $\overline{\downarrow}$ keys at this time.

- (2) Press $\overline{\text{PARA}}$ key. $\overline{\text{C}}$ $\overline{0}$ $\overline{2}$ $\square\square\square\square$ (preset value) are displayed.

Set the desired No. 1 LOW value.

- (3) Press $\overline{\text{PARA}}$ key. $\overline{\text{C}}$ $\overline{0}$ $\overline{3}$ $\square\square\square\square$ (preset value) are displayed.

Set the desired No. 2 HIGH value.

- (4) The values of No. 2 LOW, No. 3HIGH, and No. 3 LOW are set in a similar manner.

(Ex.)

$\overline{\text{PARA}}$	$\overline{\text{C}}$	$\overline{0}$	$\overline{1}$	$\square\square\square\square$	Output limiter No. 1 HIGH
$\overline{\text{PARA}}$	$\overline{\text{C}}$	$\overline{0}$	$\overline{2}$	$\square\square\square\square$	Output limiter No. 1 LOW
$\overline{\text{PARA}}$	$\overline{\text{C}}$	$\overline{0}$	$\overline{3}$	$\square\square\square\square$	Output limiter No. 2 HIGH
$\overline{\text{PARA}}$	$\overline{\text{C}}$	$\overline{0}$	$\overline{4}$	$\square\square\square\square$	Output limiter No. 2 LOW
$\overline{\text{PARA}}$	$\overline{\text{C}}$	$\overline{0}$	$\overline{5}$	$\square\square\square\square$	Output limiter No. 3 HIGH
$\overline{\text{PARA}}$	$\overline{\text{C}}$	$\overline{0}$	$\overline{6}$	$\square\square\square\square$	Output limiter No. 3 LOW

- Note: 1. Output limiters of No. 1 to No. 3 are linked with PID No. 1 to PID No. 3 respectively.
 2. The value of 100% has been previously entered for C01, C03 & C05 and 0% for C02, C04 & C06.

ERROR CODES

CODE NUMBER	MEANING	CORRECTIVE ACTION
E01	← and PROG key were pressed during displaying an entered program No. (The key operation for program setting is ineffective.)	Enter a program No. not yet used or delete the entered program.
E02	VRFY key was pressed during displaying a program No. not yet entered or a segment No. not yet entered. (A key operation to recall data not yet entered is ineffective.)	Select correctly the entered program No. to be verified.
E03	RUN key was pressed during a program No. or a segment No. not yet entered, or during displaying program No. "0" in HOLD mode. (The operation of a program not yet entered or a test program in HOLD mode is ineffective.)	Select correctly the entered program No. and put instrument in RUN mode. Return to READY mode and execute the test program.
E10	Setting parameters (upper limit - HIGH, lower limit - LOW) for output limiter HIGH/LOW or linear input HIGH/LOW was error. (Ex. Setting errors like 30% HIGH and 70% LOW are ineffective.)	Press CLR key, and reset the correct HIGH > LOW values.
E11	End of RAMP segment was defined by pressing PROG key. Or, PROG key was pressed just after the end of RAMP segment. (A program setting having no end point in the program is ineffective.)	End RAMP segment by pressing SEG key. End program after entry of SOAK segment.
E14	EVENT and PID keys were pressed just after the setting of cycle number during programming. (EVENT and PID group setting must be made before cycle setting.)	Set cycle number after segment deletion and EVENT/PID setting. Or, if it is possible to set EVENT/PID in next segment, the present segment can be ended as it is.
E15	Memory entry has already exceeded the remaining memory capacity.	End the program. Re-enter the data after deletion of unnecessary program.
E16	No. 100 segment was defined. (Segment can be set up to 99 segments.) Defining No. 100 segment is impossible.)	Re-program the segments to less than 99.
E17	Data was entered with the internal switch set to M.P position (Program entry to memory prohibited.)	Set the internal switch to M.E position and enter the data.

ALARM CODES

CODE NUMBER	MEANING	CORRECTIVE ACTION
A01	PV exceeded the upper limit of input range. Or, thermocouple input is burnout.	1. Check input wiring for breaks. 2. Check PV (process variable).
A02	PV is below the lower limit of input range. Or, RTD thermometer input is shortened.	1. Check input wiring. 2. Check PV (process variable).
A93	Data check point was lost. Or, Data to restart program after restoration of power was lost.	Verify if program pattern data and parameter data are still memorized. (Use VERIFY key.) If the data are correctly memorized, restart the program. If the data are lost, reset the data and then restart the program.
A94	Data content of parameters C01 to C10 was lost.	Reset the parameter data.
A95	Data of PID parameters were lost.	Reset the PID parameters.
A96	Data content of program pattern was lost.	Re-write the program pattern.
A97	Battery power is below operational limit.	Replace the battery. (Power supply must be OFF during replacement. After replacement, set the internal switch to M.E position, and reset G.R.)
A98	RAM is abnormal.	Return instrument to the manufacturer to replace RAM.
A99	ROM is abnormal.	Return instrument to the manufacturer to replace ROM.

Note: If instrument cannot be returned to the normal condition even after the above corrective actions, contact nearest Honeywell sales office.

MAINTENANCE AND SERVICE

1. Operation of Program No. "0"

If before or during operation or programming, the functioning of any switch or indicator light is in doubt, put instrument in READY mode and initiate the self checking program as follows.

- (1) Press ^{PROG} key and set "program No. 0".
- (2) Press ^{RUN}/_{HOLD} key.
- (3) Automatically each indicator LED repeats flashing to check for failure of indicator LED.
- (4) Start check for each key.

If each key operation and the displayed code meet the table shown below, this means that the key is normal. ^{RESET} key must be pressed last to complete program. After check of **RESET** key, instrument is automatically returned to READY mode.

CODE	KEY	CODE	KEY
<input type="checkbox"/> 01	<input type="checkbox"/> ^{RUN} / _{HOLD}	<input type="checkbox"/> 10	<input type="checkbox"/> ▼
<input type="checkbox"/> 02	<input type="checkbox"/> ^{AUTO} / _{MAN}	<input type="checkbox"/> 11	<input type="checkbox"/> ENTR
<input type="checkbox"/> 03	<input type="checkbox"/> VRFY	<input type="checkbox"/> 12	<input type="checkbox"/> PID
<input type="checkbox"/> 04	<input type="checkbox"/> PROG	<input type="checkbox"/> 13	<input type="checkbox"/> PARA
<input type="checkbox"/> 05	<input type="checkbox"/> SEG	<input type="checkbox"/> 14	<input type="checkbox"/> ^{SOAK} / _{RAMP}
<input type="checkbox"/> 06	<input type="checkbox"/> DISP	<input type="checkbox"/> 15	<input type="checkbox"/> G-SOAK
<input type="checkbox"/> 07	<input type="checkbox"/> CLR	<input type="checkbox"/> 16	<input type="checkbox"/> CYC
<input type="checkbox"/> 08	<input type="checkbox"/> ←	<input type="checkbox"/> 17	<input type="checkbox"/> EVENT
<input type="checkbox"/> 09	<input type="checkbox"/> ▲	<input type="checkbox"/> (NONE)	<input type="checkbox"/> RESET

2. Cleaning Front Mask

A stain on LED filter, key cover, or rubber key can be removed normally with a dry cloth. An oil stain or thumbmark can be removed by softly wiping it with a cloth having petrochemical benzine is applied. Do not use high purity alcohols.

3. Replacing Battery

When BAT (battery) alarm indicator lights, replace the battery (part No. 81400836A) mounted at the bottom of instrument after operation has finished. During replacement, the instrument power must be OFF. After replaced, set the internal switch to M.E position, and set the internal G.R switch to the arrow position, and then re-enter necessary data.

GLOSSARY OF SPECIAL TERMS

TERMS	EXPLANATION
Access	An action to recall the address of data in order to read out the data stored in the instrument or to write new data into the instrument.
Algorithm	A computation equation to process data in the controller or instrument. This word is normally used in computer technology or digital instrumentation, but not used much in the analog instrumentation field.
Analog-Digital Converter (A/D Converter)	An electronic circuit unit to convert analog input signal (T/C, RTD, 4-20mADC, etc.) to a digital signal for digital computation processing.
Analog Input	A continuous signal input like current or voltage from a detector or transmitter to the digital controller or process input/output device. A signal lower than 1V from thermocouple or RTD is called a low-level analog input. A signal of 4-20mADC, 1-5V, or 0-10V is called a high-level analog input.
Balanceless Bumpless	A method of switch control without causing any variation in output value and also without any necessity of output balance operation by operator. This function could not be completely realized in analog. But, the function can be easily realized in a digital controller.
Bit	The minimum unit of information. The codes "0" and "1" are used.
Byte	A minimum unit to an express word or figure by a combination of bits. Normally, one byte consists of 8 bits.
Central Processing Unit (CPU)	A central information processing unit consisting of a controller, arithmetic unit, and register.
Configuration	An action to select a control equation, alarm function and input/output processing function stored in masked ROM of controller by data setting keys, DIP switches, etc.
Hardware	A general term to express mechanical or electronic devices in a computer.
Integrated Circuit (IC)	Elements like transistors, resistors, etc. combined to build a circuit and integrated on a several-millimeter square silicon chip. IC's are classified into SSI, MSI, LSI, and super LSI by the degree of circuit integration.
Large Scale Integration (LSI)	An integrated circuit consisting of more than 1,000 elements in terms of circuit integration.
Memory	A device to memorize information. IC memory is generally used as a memory for microcomputers although core memory is partially used. There are many IC memories like RAM, ROM, PROM, etc. Each of these memories is selected by application.
Microprocessor	LSI which is used as the CPU of a computer.

TERMS	EXPLANATION
Programmable Read Only Memory (PROM)	A type of memory into which the user can electrically write data.
Random Access Memory (RAM)	A type of memory that allows the microprocessor to write data into memory or to read out of memory quickly by address designation to the data memorized at an optional memory address.
Ramp and Soak	A function to make a set point vs. time profile consisting of oblique lines (ramp) and vertical lines (soak).
Read Only Memory (ROM)	A type of memory that only allows the microprocessor to read data from the memory location. Data is maintained in memory even if power fails. ROM is used for storing function tables or programs of routine procedure in advance.
Software	An application technology to operate computer, or a general term for programming.
Word	An information unit exchanged between memory and arithmetic unit or controller as group. Normally, one order or one numerical value is equivalent to one word.

DCP511 MODEL SELECTION GUIDE

DCP511

5 G		OUTPUT CONTROL	4 to 20mA DC OUTPUT	PID CONTROL
8 D		OPERATION	TIME PROPORTIONAL OUTPUT	PID CONTROL
			SENSING ELEMENT	SCALE RANGE
T	44	RANGE	T (C.C)	-200 to 300°C
J	04		J (I.C)	0 to 400°C
E	07		E (C.R.C)	0 to 400°C
E	08			0 to 800°C
K	06		K (C.A)	0 to 600°C
K	09			0 to 1200°C
S	16		S	0 to 1600°C
R	16		R	(P.R)
B	18		B	
D	18		PR 40-20	0 to 1800°C
W	23		W 5 WRe26	0 to 2300°C
P	48		Pt 100Ω RTD	-180.0 to 200.0°C
P	05			0.0 to 500.0°C
N	35		Ni 508Ω RTD	-50.0 to 150.0°C
C	01			4 to 20mA DC
V	01		1 to 5V DC	PROGRAMMABLE RANGE
M	01		0 to 10mV DC	PROGRAMMABLE RANGE
	1	POWER SUPPLY VOLTAGE	100/110VAC, 50-60Hz	
	2		200/220VAC, 50-60Hz	
	5		120VAC 50-60Hz	
	6		240VAC 50-60Hz	
	00	ADDED FUNCTION	NONE	

[EXAMPLE]

