

DigitroniK Digital Program Controller DCP216

User's Manual

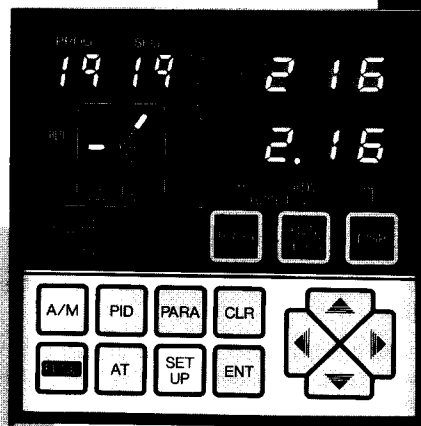

Yamatake Corporation

RESTRICTIONS ON USE

When using this product in applications that require particular safety or when using this product in important facilities, pay attention to the safety of the overall system and equipment. For example, install fail-safe mechanisms, carry out redundancy checks and periodic inspections, and adopt other appropriate safety measures as required.

REQUEST

Make sure that this Instruction Manual is handed over to the user before the product is used.

Copying or duplicating this Instruction Manual in part or in whole is forbidden. The information and specifications in this Instruction Manual are subject to change without notice.

Considerable effort has been made to ensure that this Instruction Manual is free from inaccuracies and omissions.

If you should find any inaccuracies or omissions, please contact Yamatake Corporation.

In no event is Yamatake Corporation liable to anyone for any indirect, special or consequential damages as a result of using this product.

©1991 Yamatake Corporation ALL RIGHTS RESERVED

The DigitroniK ® is a registered trademark of Yamatake Corporation.
DCP216 is trademark of Yamatake Corporation.

This manual describes how to use this product. Before using this product, thoroughly read and understand the descriptions in this manual to ensure correct use.

After you have read this manual, store the manual a safe place nearby so that it can be referred whenever needed.

Restrictions Upon Use

When using this product in applications that require particular safety or when using this product in important facilities, pay attention to the safety of the overall system and equipment. For example, install fall-safe mechanisms, carry out redundancy checks and periodic inspection, and adopt other appropriate safety measures as required.

⚠ WARNINGS

- Before connecting or disconnecting wiring to or from this product, be sure to turn the mains power supply OFF. Inadvertently touching terminals or other electrically live parts might cause electrical shock.
- Before connecting this product to the measurement target or external control circuits, make sure that it is connected to an earth. Failure to do so might cause electrical shock or fire.

⚠ CAUTIONS

- Wire this product properly in accordance with predetermined wiring standards, instruction described in this manual and generally accepted wiring methods. Failure to do so might result in electrical shock, fire or malfunction.
- Use this product only within the recommended operating conditions (temperature, humidity, voltage, vibration, shock, atmosphere, etc.) described in the specifications.
- Do not cover the ventilation holes on this product. Doing so might result in fire or malfunction.
- Do not disassemble this product, or touch parts inside. Doing so might result in electrical shock or malfunction.
- Some parts in this product become hot while the power is turned ON or are hot immediately after the power is turned OFF. Do not touch these parts. Doing so might result in burns.
- Do not operate the operation keys on this product with the top of a propelling pencil or other sharp-tipper object. Doing so might result in malfunction.

SAFETY REQUIREMENTS



To reduce risk of electrical shock which could cause personal injury, follow all safety notices in this documentation.



This symbol warns the user of a potential shock hazard where hazardous live voltages may be accessible.

- * If the equipment is used in a manner not specified by the manufacturer, the protection provided by the equipment must be impaired.
- * Do not replace any component (or part) not explicitly specified as replaceable by your supplier.
- * All wiring must be in accordance with local norms and carried out by authorized experienced personnel.
- * The ground terminal must be connected before any other wiring (and disconnect last).
- * A switch in the main supply is required near the equipment.
- * Mains power supply wiring requires a (T) 2A, 250V fuse(s).

Installation category : Category II (IEC664-1, IEC1010-1)

Specification of common mode voltage : The common mode voltages of all I/O except for main supply and relay outputs are less than 30Vrms, 42.4Vpeak and 60Vdc.

EQUIPMENT RATINGS

Supply voltage	90 - 264 V~
Frequency	50/60Hz
Power or current ratings	17.5VA maximum

EQUIPMENT CONDITIONS

Do not operate the instrument in the presence of flammable liquids or vapors. Operation of any electrical instrument in such an environment constitutes a safety hazard.

Temperature	0 to 50°C	
Humidity	10 to 90% RH	
Vibration	Frequency	10 to 60Hz
	Acceleration	0,5g maximum

EQUIPMENT INSTALLATION

The controller must be mounted into a panel to limit operator access to the rear terminals.

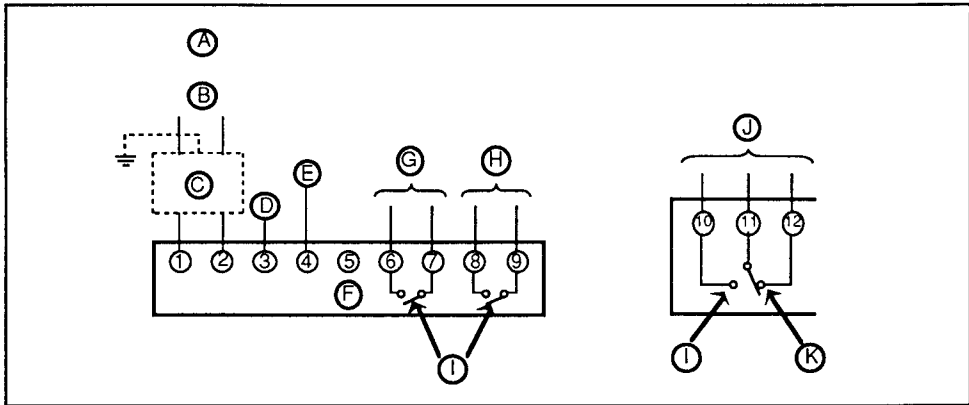

(A)	Instrument power supply
(B)	90 to 264 V AC
(C)	Noise filter
(D)	GND
(E)	Shielded GND
(F)	Idle
(G)	Event 1 output (relay contact)
(H)	Event 2 output (relay contact)
(I)	Normally open
(J)	Relay output
(K)	Normally close



TABLE OF CONTENTS

<p>FUNCTION 2</p> <p> 1. GENERAL 2</p> <p> 2. CONSTANTS AND PROGRAMMING 3</p> <p>PROGRAMMING AND OPERATION 4</p> <p> 1. CONTENTS OF DISPLAYS AND FUNCTIONS OF KEYS 4</p> <p> 2. OUTLINE OF PROGRAMMING 6</p> <p> 3. PROGRAMMING MODE 8</p> <p> (1) PROGRAMMING MAP 9</p> <p> (2) PROGRAMMING 10</p> <p> 4. SETUP MODE (INITIALIZE) 12</p> <p> (1) SETUP MODE SETTING PROCEDURE 14</p> <p> 5. PARAMETER MODE (CONSTANTS SETTING) 19</p> <p> (1) PARAMETER MODE SETTING PROCEDURE 20</p> <p> (2) MAIN FUNCTION SETTING 22</p> <p> (3) PROGRAM PATTERN SETTING 22</p> <p> (4) SUBFUNCTION SETTING 25</p> <p> 6. PID TUNING MODE (PID CONSTANTS SETTING) 30</p> <p> (1) PID TUNING PROCEDURE 31</p> <p> 7. OPERATION MODE IN PROGRAM OPERATION 32</p> <p><OPERATION EXAMPLES> 33</p> <p> 1 STARTING A PROGRAM 33</p> <p> 2 STARTING A PROGRAM FROM A PRESENT TEMPERATURE 33</p> <p> 3 HOLDING A PROGRAM 33</p> <p> 4 ADVANCING A PROGRAM TO A NEW SEGMENT 33</p> <p> 5 STARTING AUTO TUNING 34</p> <p> 6 SELECTING MANUAL CONTROL FOR THE PROCESS 34</p> <p> 7 STOPPING A PROGRAM 35</p> <p> 8 COPYING STORED PROGRAM DATA UNDER A DIFFERENT PROGRAM NUMBER 35</p> <p> 9 CHANGING PROGRAM DATA 36</p> <p> 10 STORING THE SETTING RANGE LIMITS OF A PROGRAM 36</p> <p> 11 DELETING STORED DATA 36</p> <p> 12 ALARM CODE DISPLAY 37</p> <p> 13 CONDITION AFTER RECOVERY FROM A POWER FAILURE 37</p> <p> 14 READ CONDITIONS 37</p> <p>8. REMOTE OPERATION 38</p> <p>9. CONTENT OF PROGRAM 39</p> <p> 1 MAIN FUNCTIONS 39</p> <p> (1) SOAK SEGMENT 39</p> <p> (2) RAMP SEGMENT 39</p> <p> 2 SUBFUNCTIONS 40</p> <p> (1) PROCESS VARIABLE-BASED EVENT CIRCUITS 40</p> <p> (2) DEVIATION-BASED EVENT CIRCUITS 41</p>	<p>(3) RUN, READY, AND END EVENT ... 42</p> <p>(4) TIME-BASED EVENT CIRCUITS 42</p> <p>(5) PID GROUP SELECTION 44</p> <p>(6) GUARANTEE SOAK 44</p> <p>(7) PV START 45</p> <p>(8) AUTOMATIC CYCLING OF A PROGRAM 45</p> <p>(9) PROGRAM LINK 46</p> <p>(10) PV SHIFT 46</p>
---	---

<p>10. OPERATION MODE IN CONSTANT VALUE CONTROL OPERATION 47</p> <p> 1 CONSTANT VALUE CONTROL OPERATION MODE 47</p> <p> I. OUTLINE OF PROGRAMMING 47</p> <p> 1. NUMERICAL CHANGE PID KEYS 47</p> <p> 2. NUMERICAL CHANGE PARA KEYS 48</p> <p> 3. KEYS WHICH ARE NOT EFFECTIVE FOR CONSTANT VALUE CONTROL 48</p> <p> II. OUTLINE OF OPERATION 49</p> <p> 1 STARTING A PROGRAM 49</p> <p> 2 STARTING AUTO TUNING 49</p> <p> 3 SELECTING MANUAL CONTROL FOR THE PROCESS 49</p> <p> 4 STOPPING A PROGRAM 49</p>	<p>11. MODEL SELECTION GUIDE AND SPECIFICATIONS 50</p> <p>12. EXTERNAL DIMENSIONS 53</p> <p>13. INSTALLATION 54</p> <p>14. WIRING 55</p> <p>15. EXTERNAL WIRING DIAGRAM 57</p> <p>16. MAINTENANCE 59</p> <p>17. APPENDICES 60</p> <p> (1) PROGRAM PREPARATION EXAMPLE 61</p> <p> (2) SETUP SETTING EXAMPLE 62</p> <p> (3) PARAMETER SETTING EXAMPLE 62</p> <p> (4) PROGRAMMING EXAMPLE 63</p> <p> ☆ COMMENTS ON ABBREVIATIONS 67</p> <p style="text-align: center;">PROGRAM WORK SHEET</p>
---	---

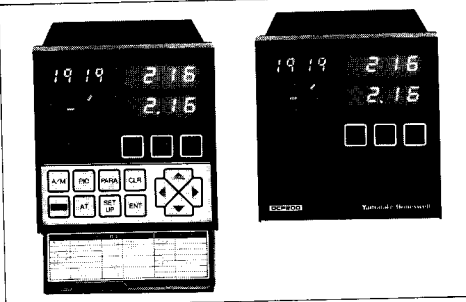

FUNCTION

1.

GENERAL

1. General

The DCP216 is a microprocessor-based program controller (96 mm×96 mm in size) which executes program control of temperature, humidity, pressure, flow, and other process variables.

2. Features

- Multiranges
 - Sensors can be replaced without any need of adjustment in each group of thermocouples, resistance thermometer bulbs, and linear inputs (current, voltage).
- SP limit
 - Since the DCP216 can limit a data setting range, it can prevent troubles due to wrong setting.
- Profile display
 - The DCP216 displays present segment conditions (rising, soaking, falling), and the next segment conditions during program run.
- Auto tuning (option)
 - Since the DCP216 automatically calculates PID constants at the start-up time, you can entrust the DCP216 with troublesome tuning.
- Program link function
 - Owing to this program link function, the DCP216 can execute complicated programming and partial cycling.
- Constant value control
 - The single DCP216 serves as a program controller and a constant value controller.
- Free power supply
 - Since the DCP216 is applicable to 90 to 264 V ac, it can be operated with any of 100, 110, 120, 200, 220, and 240 V ac power supply without reconnecting power terminals.

3. Outline of functions

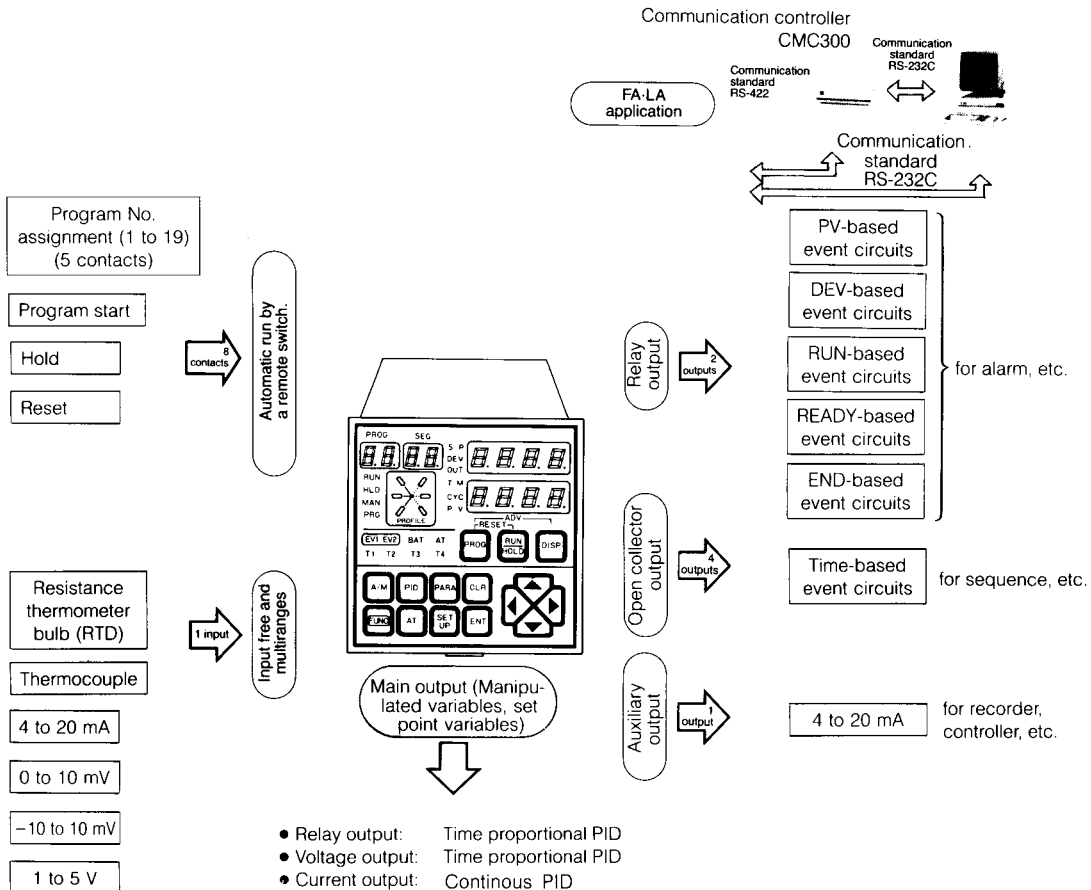

2. CONSTANTS AND PROGRAMMING

1. Content of program: DCP216 constants and programming

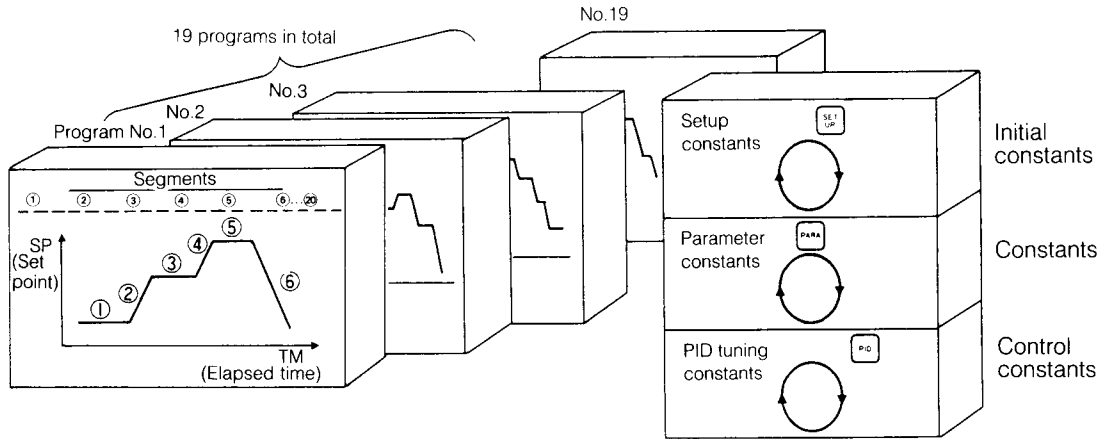

For running the DCP216, the above setting is necessary. Respective setting modes are provided.

(1) Setting of constants

Constants are divided into three groups, and operated by **SET UP**, **PARA**, and **PID** keys, respectively.

(a) Setup constants

Setup constants are initially set as a program controller. After setting, the constants are not changed frequently.

(b) Parameter constants

These constants are changed comparatively frequently.

(c) PID tuning constants

These constants are provided for PID control. (* SP and EV values are also set in this mode in the constant-value control.)

(2) Programming

Programs No.1 to 19 can be programmed. Max. 20 segments per program can be set.

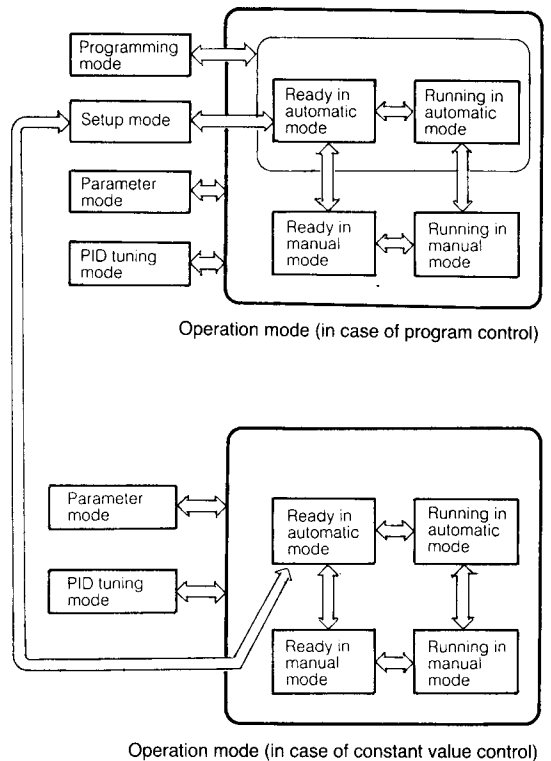

PROGRAMMING AND OPERATION

1. CONTENTS OF DISPLAYS AND FUNCTIONS OF KEYS

(For abbreviations, refer to pages 66, 67)

Contents of displays



Program No. display:
Displays a selected program No.
Displays A, if an alarm occurs.



Segment No. display:
Displays a selected segment No.
Displays an alarm code, if an alarm occurred.

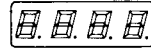

Upper display:
Displays SP, DEV, OUT, TIME, etc.

Upper and lower display indicators:
Indicates the contents of the upper and lower displays.



Mode indicator LED lamps:
Indicates RUN, HOLD, MAN, and programming modes.



Profile indicator LED lamp:
Indicates the rising, soaking, and falling tendencies of a program pattern by 2 segments.

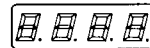

Lower display:
Displays SP, TIME, CYC, etc.

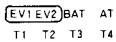

EV (event) indicator LED lamp:
Indicates the event action.
Indicates an event setting in programming mode.

BAT (battery) alarm LED lamp:
Flickers when the battery voltage becomes lower than specified.

AT (auto tuning) indicator LED lamp:
Flickers during the execution of auto tuning.

T1, T2, T3, T4 (time event) indicator LED lamps:
Indicates the event action.
Indicate an event setting in programming mode.

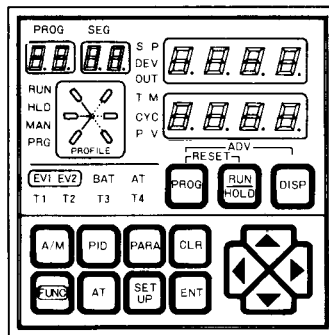

Functions of keys

A/M AUTO/MANUAL key:
Selects AUTO or MANUAL mode.

PID PID key:
Changes the setting of PID constants.

PARA Parameter key:
Sets and changes parameter constants.

CLR Clear key:
Deletes program data with FUNC key combined.

PROG Program key:
Selects and assigns a program number.

RUN/HOLD RUN/HOLD key:
● Sets the mode from READY to RUN.
● Selects RUN or HOLD.

DISP Display key:
● Changes the display selection.
● Interrupts the setting action, and other action.

FUNC Function key:
Used together with other keys.

AT Auto tuning key:
Starts or interrupts the execution of auto tuning.

SET UP Set up key:
Sets up constants.

ENT Enter key:
● Used to change data.
● Enters data in memory.



Multi-keys:
● One of these 4 keys is used for data setting and programming item shift.
○ These keys increase or decrease a flashing digit, or select a flashing digit for change.

Key operation

Simultaneous pressing of two keys:

In the case of key operation like + , press key while pressing key.

Two keys are pushed together at a time in 5 ways as shown in the right table. Press a key in column B while pressing a key in column A in such a case.

Operation	A	B
Reset (RESET)	PROG	RUN HOLD
Advance (ADV)	PROG	DISP
Programming start	FUNC	PROG
Program data erase	FUNC	CLR
Program copy	▲	PROG

Operation of specific keys

1. · · operation

⇒ Press key when you want to complete the set-up, parameter mode, or PID tuning.

- Select an operation mode by , , or key.
- Select each mode item by , , , , or key.
- Specify by key, if you want to change data. Data flushes.
- Change data by key.
- Store data by key.

2. Key operation in programming mode

⇒ Press key when you want to complete the programming mode.

- Select No. by key.

The program number is fed forward by key, or backward by key.

- Press + keys, and PRG (PROG) LED lamp lights.

- Operate keys according to the lighting condition of PRG (PROG) lamp as follows.

When a digit is flashing to be ready for changing the value; Shifts the flashing location of a digit leftward.

↑ Increases the flashing digit.
 Shifts the flashing location of a digit rightward.
 ↓ Decreases the flashing digit.
 ← Returns to the previous item.

When no digit is flashing and a mode item is selected; Returns to the previous segment.

↑ Advances to the next segment.
 Advances to the next item.

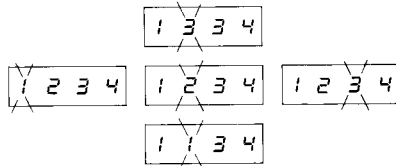

By pressing key when no digit is flashing, the digit will start to flash to be ready for changing the value.

By pressing key when a digit is flashing, the data can be stored in memory.

2. OUTLINE OF PROGRAMMING

Turn on the power supply

Reset the programmer first, if it is operating.

Resetting method

Press **RUN HOLD** key while pressing **PROG** key.

In case of the ready mode:

Perform setting operation based on each mode.

Instruction pages of modes	Display at the start of mode	Setting example in a specified mode	Operation methods
SET UP Setup mode (Initialization) See page 18.	Press SET UP key. (SP) C I		<ul style="list-style-type: none"> Each code from C I to C 3 appears in a display when SET UP key is pressed sequentially. If C I is not displayed, press DISP key and then, press SET UP key again.
PARA Parameter mode (Constant value setting) See page 24.	Press PARA key. (SP) P r t c		<ul style="list-style-type: none"> Each code from P r t c to H Y S 2 appears in a display when PARA key is pressed sequentially. If P r t c is not displayed, press DISP key and then, press PARA key again.
PROG Programming mode (Program setting) See page 29. (Note) Set the program mode first.	Press ENT key. SP --- TM --- PROG ! SEG ! PRG ! PROFILE !		<ul style="list-style-type: none"> Select the programming mode by pressing PROG key while pressing CLRD key. PRG LED lights.
PID Tuning mode (PID constants setting) See page 36.	Press PID key. (SP) R t		<ul style="list-style-type: none"> Each code from R t to i o u t appears in a display when PID key is pressed sequentially. If R t is not displayed, press DISP key and then, press PID key again.
RUN HOLD Operation mode (Running operation) See page 38.	Press RUN HOLD key. PROG SEG ! ! SP 2 1 1 TM 0.1 0	<ul style="list-style-type: none"> RUN LED lights. LED lights on PROFILE to indicate the progress of a program. 	<ul style="list-style-type: none"> Press DISP key, and then press RUN HOLD key.

MODE TRANSITION DIAGRAM

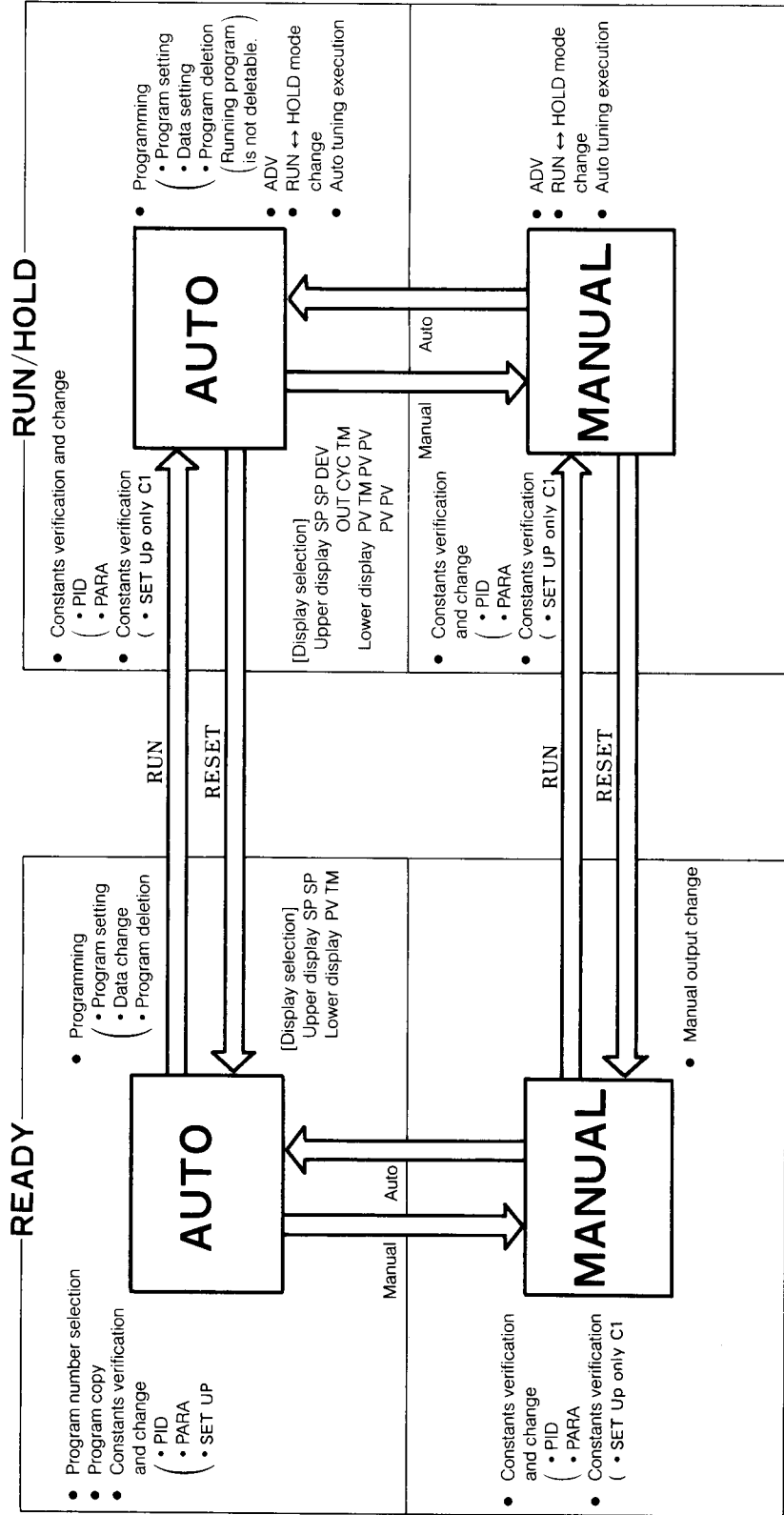

3.

PROGRAMMING MODE

Map type programming

- 1 Set the segments (patterns) on the abscissa first.
- 2 Set EV₁, EV₂, T₁ to T₄, PID, guarantee soak, PV start, cycle number program link, and PV shift on the ordinate next.
- 3 Set the ordinate for every segment.
- 4 The  keys freely move on the map.
- 5 The present segment conditions (soaking, rising, falling) are indicated by LED lamps on the profile indicator.

Segment No. can be freely called by  multi-keys.

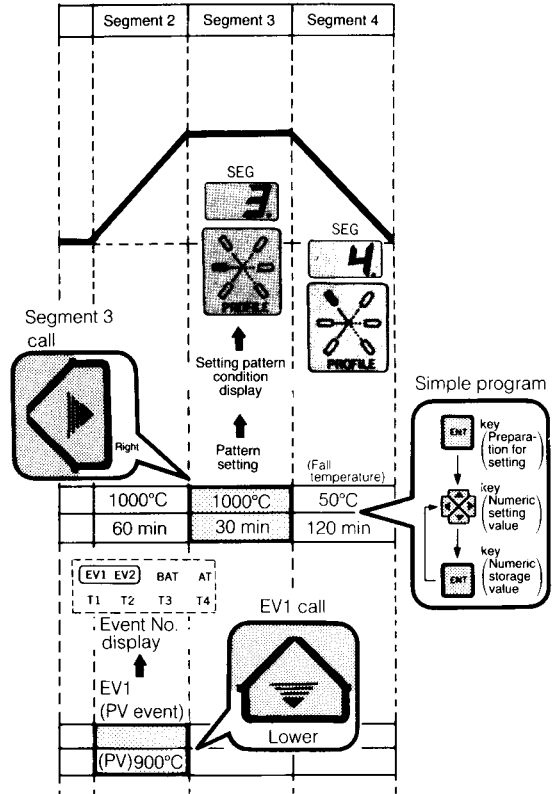

PROGRAMMING MAP

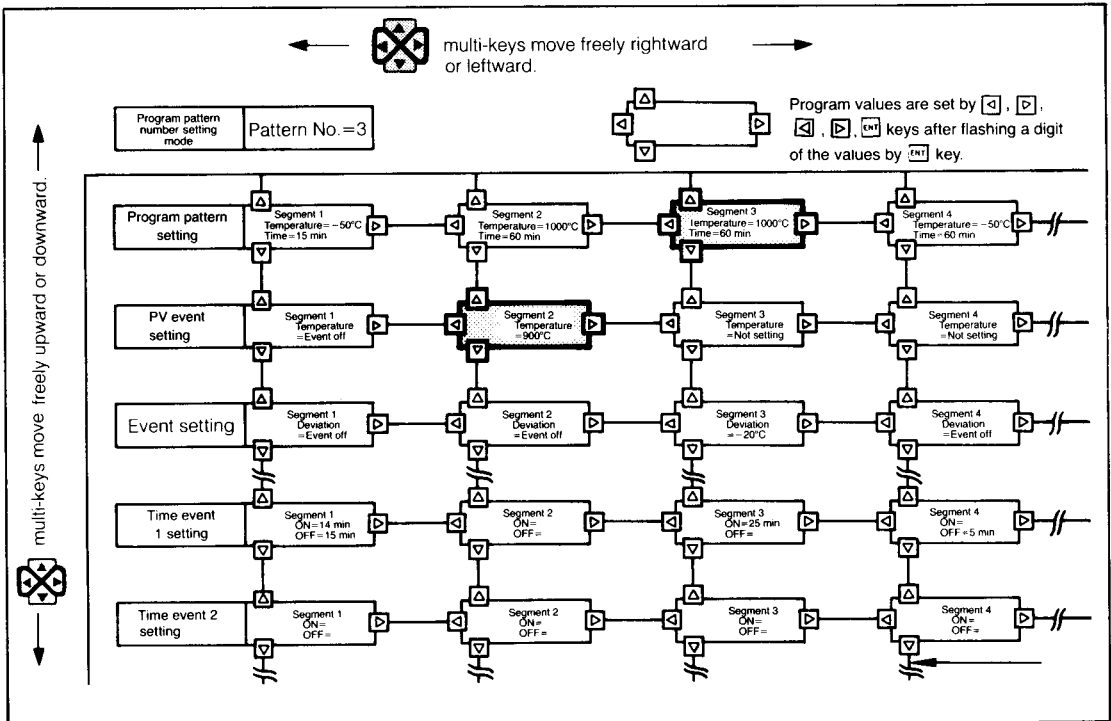

PROGRAMMING MAP

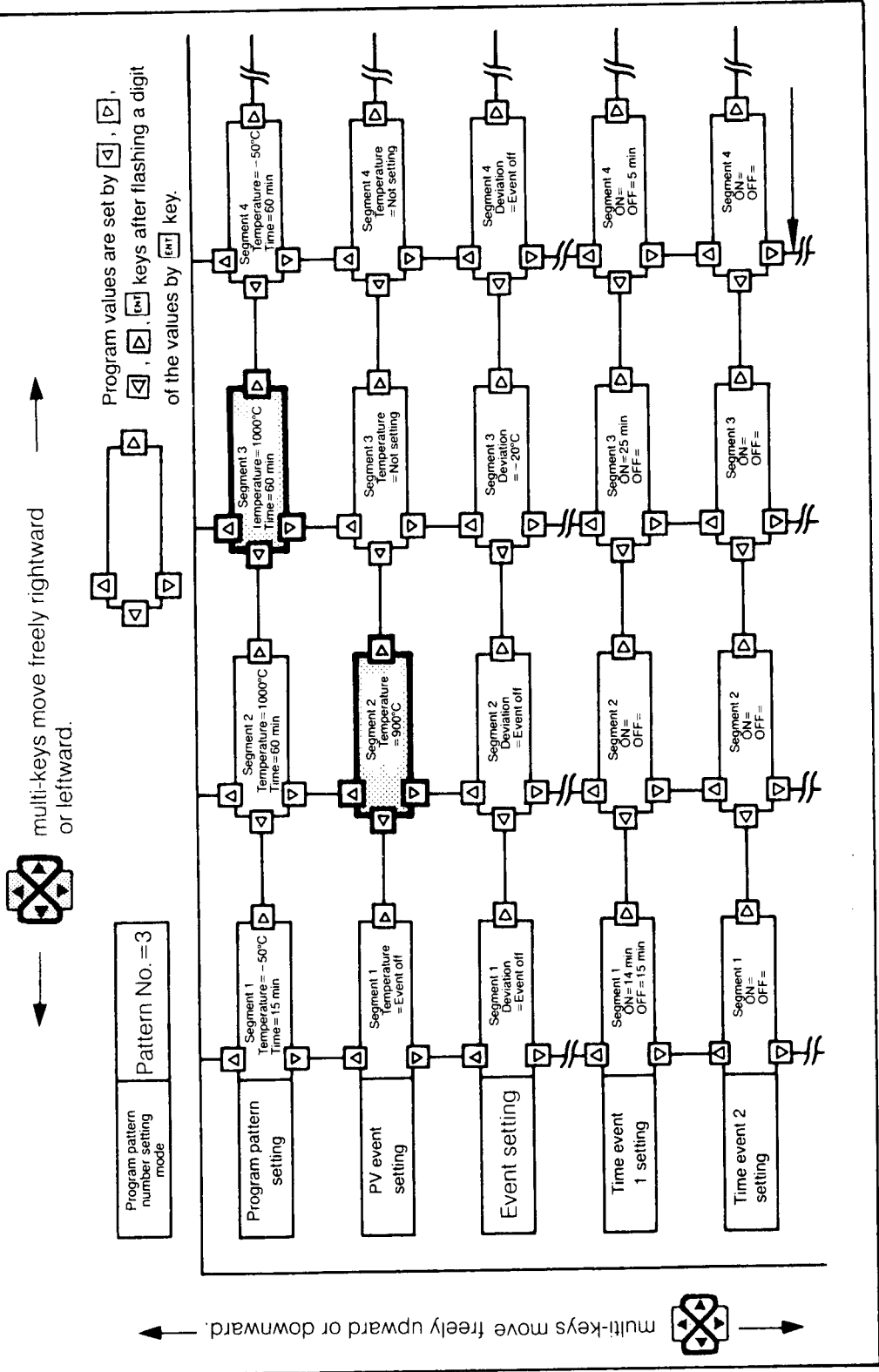

(1) PROGRAMMING MAP

This table consists of lines of each programming item and row of each segment.

Map position	Item display position			Segment				Lighting lamp
				1	2	20	
A	SP and time	Upper display	SP *1					SP, TM
		Lower display	Time *1					
B	No. 1 event	Upper display	Event set point *1		B2 position			PV or DEV EV1
C	No. 2 event	Lower display	Event set point *1					PV or DEV EV2
D	No. 1 time event	Upper display	ON time *1					T1
		Lower display	OFF time *1					
E	No. 2 time event	Upper display	ON time *1					T2
		Lower display	OFF time *1					
F	No. 3 time event	Upper display	ON time *1					T3
		Lower display	OFF time *1					
G	No. 4 time event	Upper display	ON time *1					T4
		Lower display	OFF time *1					
H	PID group selection	Lower display	Group No.					"P I d"
I	G.SOAK setting	Lower display	no : Not set YES : Set					"G.S."
J	PV start setting	Lower display	no : Not set YES : Set	Common setting to each segment				"P.S.E.R"
K	Cycle setting	Lower display	Cycle number *2	Common setting to each segment				"CYCL"
L	Program link setting	Lower display	Link destination program No. is set	Common setting to each segment				"P.LIN"
M	PV shift setting	Lower display	Shift value *3					"SHIFT"

(Notes) *1: If not set, "----" is displayed

When RUN, READY, or END event is specified by EV1 or EV2, its item itself is not displayed.

*2: These segments can be set by one every program, and data are equal every program.

*3: No display appears when SETUP C20=0.

• The frame position is specified by combining the alphabetic characters (A to K) showing program map items with the numbers (1 to 20) showing segments. The frame of event No. 1 of segment 2 is represented as .

• Program setting, change, check, and other programming operations are executed by displaying the contents of each frame of the above programming map on the displays. The vertical move (items) and horizontal move (segments) of the frame of the pro-

gramming map are executed by multi-keys when displayed data are not flashing. If setting or change is not required, press key once or twice to flash the aimed data and change data by keys. Then, store the data by pressing key.

* Since a blank programming map is attached to this manual at the last page, it is recommended to fill each item before starting the programming work for correct setting with a reduced setting time.

(2) PROGRAMMING

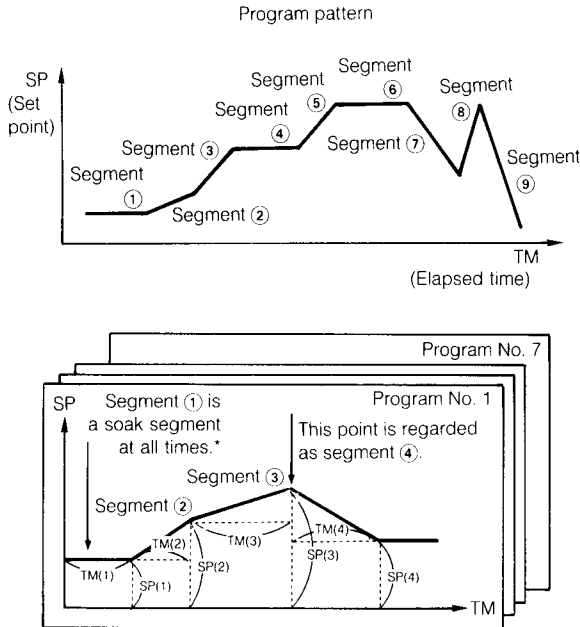

Fig. 2-1 Program concept

A broken line determined by set points of industrial values (temperature, humidity, pressure, flow, rotating speed, and other variables) to the time is called program pattern (or simply program or pattern).

Program patterns are identified from each other by program numbers (1 to 7).

Individual straight lines composing a program pattern are called segments, which are identified from each other by segment numbers (1 to 20).

A “—” portion of a segment is called soak (soaking), while a “/” portion is called ramp (rising or falling).

In the following figure, the n-th segment is specified by a set point of the N-1-th segment, N-th set point, and N-th time setting; provided that the first segment is regarded to be set constant.

The constant of the N-th segment and the N+1-th segment is regarded as the N+1-th start point.

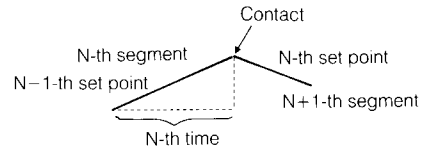

Program No. 1					
Segment 1		Segment 2		Segment 3	
Main function	Subfunction	Main function	Subfunction	Main function	Subfunction

- (1) Main function Sets a program pattern by set points and time.
 - ① Soak Setting of soaking section (every segment)
 - ② Ramp A rising or falling section to be set by the next aimed set point and arrival time (every segment).
- (2) Sub function Adds events and other functions.
 - ① Event (EV1, EV2) PV-based event circuits: Used for sending a sequence output by PV (every segment).
DEV-based event circuits: Used for sending a sequence output by a deviation between a set point and PV (every segment).
RUN, READY event: Used for sending a sequence output to recognize the end of program operation.
 - ② Time-based event circuits (T1, T2, T3, T4) Used for sending a sequence output by time (every segment).
 - ③ Pid Specifies the PID group number (every segment). The setting range of the PID group selection is “0” to “9” in programming. When “0” is set, the PID group selection of the preceding segment is continued. However, the setting range in the 1st segment is “1” to “9”. Therefore, when the running advances to the 1st segment due to cycle or pattern link, the PID group selection cannot be continued. When a new segment is programmed, the initial value of the PID group selection is “1” in the 1st segment, or “0” in the other segments.
 - ④ Guaranteed soak (9.5.) Stops the progress of time until a process variable enters within the guaranteed soak band at the segment start point (every segment).
 - ⑤ PV start (P.S.E.R) Used for adjusting the start point to the point where PV is equal to a set point (every program).
 - ⑥ Cycle (C.Y.C.L) Used for repeating the same program.
 - ⑦ Program link (P.L.I.N) Used for linking with other programs by inputting program No. of the linkage destination (every program).
 - ⑧ PV shift (S.H.F.T) Used for biasing PV every segment.

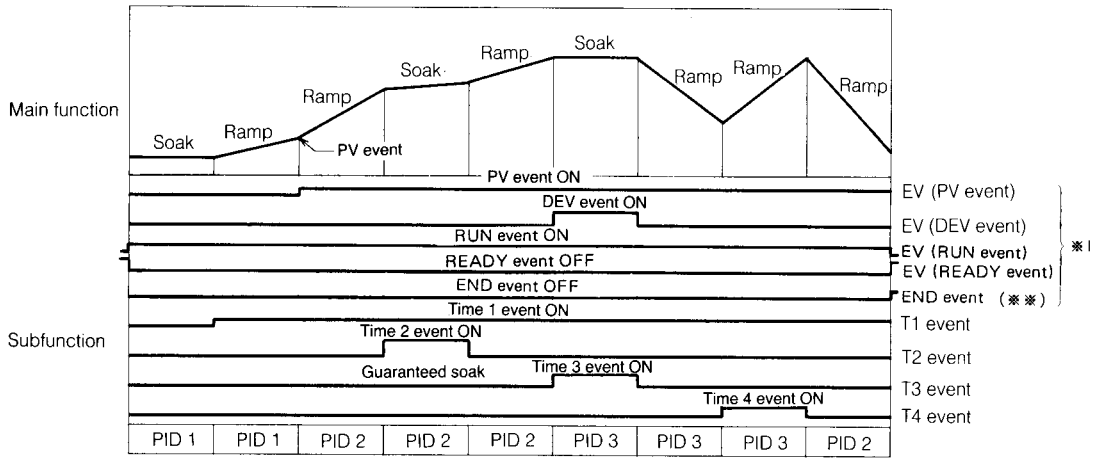

*1: Two can be selected out of five EVs.
 **: Turned off by remote or communication RESET operation.

General

The setup mode decides the specifications as a program controller. The upper display shows a setup code representing a setup item, while the lower display shows setup data. This mode is executed in ready (ready for run) mode.

If an initial value satisfies the required specifications, the setup data change is not necessary. Proceed to the parameter mode on page 24 in such a case.

(Note) Initial values in the display show those set before the delivery from the factory.

Display/ setting order	Codes	Setup item	Selection or setting range	Initial value in display	Description
1	C 1	Key lock	0: No keylock. 1: Setup change is not allowable. 2: Data are not changeable. 3: DISP only is changeable.	0	No keylock.
2	C 2	Temperature unit	0: °C (Centigrade) -1: °F (Fahrenheit)		Indicated in case of a thermocouple or resistance thermometer bulb input.
3	C 3	Control action	0: Reverse action 1: Direct action	0	Not indicated, if the main output of the current output model is SP. If initial value 0 is changed to 1 in C 4, C 5 appears.
4	C 4	Setting of manipulated variable (MV) in case of PV overrange.	0: Not provided 1: Provided	0	
5	C 5	Manipulated variable (MV) in case of PV overrange	0.0 to 100.0% (Time proportional model) -10.0 to 110.0% (Current output model)	0.0 (%)	
6	C 6	Type of PV range	0 to 12 (T/C) 20 to 34 (RTD) 40 to 45 (Linear)		
7	C 7	Linear PV decimal point position	0 to 3	0	Displayed for a linear input model.
8	C 8	Linear PV lower limit	-1999 to upper-limit U	0	
9	C 9	Linear PV upper limit	Lower limit to 9999U	1000	
10	C 10	SP limit lower-limit	0% FS to upper limit of range	0	Different depending upon the type of PV range code.
11	C 11	SP limit upper-limit	Lower-limit to 100% FS of range	100	Different depending upon the type of PV range code.
12	C 12	Type of main output	0: MV 1: SP	0	Displayed in case of a current output model MV: Control output SP: Set point output for controller
13	C 13	SP main output 4 mA setting	-1999 to 9999U	0 (%FS)	Displayed when initial value 0 is changed to 1 in C 12 in case of a current output model.
14	C 14	SP main output 20 mA setting	-1999 to 9999U	100 (%FS)	
15	C 15	Type of auxiliary output	0: PV 1: SP	0	Displayed when an auxiliary output is provided PV: Process variable SP: Set point
16	C 16	Auxiliary output 4 mA setting	-1999 to 9999U	0 (%FS)	Set in industrial unit.
17	C 17	Auxiliary output 20 mA setting	-1999 to 9999U	100 (%FS)	

Display / setting order	Codes	Setup item	Selection or setting range	Initial value in display	Description
18	C18	EV1, 2 programming	0: Item is displayed at the programming. 1: Item is not displayed at the programming.	0	Whether programming item is displayed or not is merely set.
19	C19	T1-T4 programming	0: Item is displayed at the programming. 1: Item is not displayed at the programming.	0	Each programmed function is effective, irrespective of whether it is displayed or not.
20	C20	PID group, G.SOAK programming	PID group G.SOAK PV shift 0: Displayed 0: Displayed 0: Not displayed 1: Not displayed 1: Not displayed 1: Not displayed 2: Displayed 2: Displayed 2: Displayed 3: Not displayed 3: Not displayed 3: Displayed Whether item is displayed or not is indicated.	0	
21	C21	PV start, cycle, program link, programming	0: Item is displayed at the programming. 1: Item is not displayed at the programming.	0	
22	C22	Communication address	0 to 254	0	Displayed when the communication function is provided.
23	C23	Transmission speed	0: 9600 1: 4800 2: 2400 3: 1200 (BPS)	0	Designated communication address when the communication function is provided.
24	C24	Communication code	0: 8-bit even parity, 1 stop 1: 8-bit parity is not provided, 2 stop	0	
25	C25	Transmitting codes	0: Binary (for CMC300/400 MA500 DIM) 1: ASCII (for MX100 SCM)	0	See when communication function is provided.
26	C26	PV	0: Displayed 1: Not displayed 2: Not displayed, but fixed to 0% of the range.	0	
27	C27	Time display	0: Residual segment time 1: Elapsed run time	0	
28	C28	Alarm display	0: Displayed 1: Not displayed	0	
29	C29	Program time unit	0: Hour, minute 1: Minute, second	0	
30	C30	Input/output type, option type	(Hexadecimal number)	—	Not rewritable. (*1) Initial value is 0.4.0.0 in the display in case of K09 (0 to 1200°C), for example.
31	C31	Instrument code	135	135	Not rewritable.
32	C32	ROM ID	27	27	
33	C33	ROM version	Depends upon ROM versions	—	
34	C34		0: Program operation mode 1: Constant value operation mode	0	The constant value control is set by selecting 1.
35	C35 *2	A/M changeover selection	0: Normal selection Bumpless output 1: Normal selection Preset output 2: Switch selection Bumpless output 3: Switch selection Preset output	0	When the switch selection is selected, the console A/M key and communication A/M selection are not effective. Bumpless system changeover is always executed when C12=1 (SP output) with the 5G output.
36	C36	Preset manual output value	0.0 to 100.0% (0D, 6D output) -10.0 to 110.0% (5G output)	0.0	Not displayed when C12=1 (SP output) with the 5G output.
37	C37	Operation mode selection	0: Operation 3 mode selection 1: Operation 4 mode + Trigger input	0	3 mode; RUN, HOLD, RESET 4 mode; RESET, RUN, HOLD, ADV

*2: The switch used for switch selection is connected to the No.26 terminal, which is used normally for selection of the '10' place of program number in program selection. When this switch is turned off, the automatic operation is selected; when it is turned on, the manual operation is selected.

(*1) Table of combinations of initial values in the display for the item 30.

No.1 digit	No.2 digit	No.3 digit
Model number optional function (1)		
0 : 000	1 : Voltage output	0.0 : Thermocouple input
8 : 001		
4 : 002	2 : Relay output	0.1 : RTb input
C : 003		
6 : 004	4 : Current output	0.2 : Linear input
S : 005		
E : 006		
d : 007		

(1) Setup mode setting procedure

Refer to the key operation on page 5. For the setup contents, see page 12. Although there are setup items from No.1 to No.34, the setup setting procedures for the selected setup items will be described here.

Press key first.

1 Key lock

SP Initial setup display:
0: Indicates that no key lock function is provided.

TM

Set the number in the lower display to 2 when specifying the data to be unchangeable.

The digit flashes when pressing key.

Increase the number to 2 by pressing this key.

Press key.

2 Temperature unit

Temperature unit is initially set to °C (centigrade).
Initial setup display:
0: Indicates centigrade (°C).

SP For changing the temperature unit to °F (Fahrenheit), set the number in the lower display to -1.

TM

The digit flashes when pressing key.

Increase the number to 1 by pressing this key.

SP Press key.

3 Control action

Initial setup display:
0: Indicates the reverse control action.

SP The digit flashes flickers when pressing key.

TM

Set the number in the lower display to 1 for changing the control action to direct control action.

Increase the number to 1 by pressing this key.

SP Press key.

- This item selects either reverse action or direct action of the control output.
The control output is initially set to the reverse action. Switch the control output by this item if the direct action is necessary.
- 0: Reverse action As process variable increases, the control output decreases. This action is generally used for heating control, etc.
- 1: Direct action As process variable increases, the control output increases. This action is generally used for cooling control, etc.

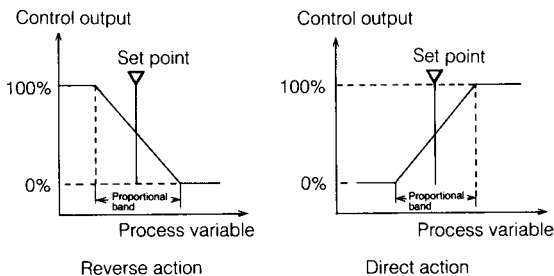

4 Setting of manipulated variable in case of PV overrange

SP Initial setup display:
0: Not provided. Not designated.

TM

Set the number of the lower display to 1 for changing to "Provided, Designated".

This item specifies the control output when an input exceeds the upper/lower-limit values of the range. This item is utilized for specifying the control output to safety when an input signal is interrupted.

5 Manipulated variable in case of PV overrange

Proceed to when is selected at .

SP Initial setup display:
0 0: 0.0 to 100.0% (0D, 6D models)
-10.0 to 110.0% (5G model)

TM

Set the value in the lower display to 50.0 for changing the setting range to 50.0.

The digit flashes when pressing key.

TM

Shift the flashing location of a digit by pressing this key.

SP Increase the flashing digit to 5 by pressing this key.

TM Pressing key.

7 Linear PV decimal point position

SP Initial setup display:
 TM 0: Indicates that the decimal point is not used.

This item determines the decimal point position for the linear input (C01: 4 to 20 mA dc, M01: 0 to 10 mA dc, V01: 1 to 5 V dc) range designation. Select a number from the following table for a suitable decimal point position.

Decimal point position	Initial value selection range
× × × ×	0
× × × . ×	1
× × . × ×	2
× . × × ×	3

For displaying a 4 to 20 mA dc input as a 0 to 1000 range, the following setting is made.

Decimal point position	0
Lower-limit value	0
Upper-limit value	1000

If you want to set the unit to PPM, the unit can be set and indicated to 0 to 1000 PPM by labeling the attached industrial unit to the right of the upper- and lower-displays.

Press key for proceeding to the lower limit item.

SP
 TM The initial setup display: 0.0.

Press key for proceeding to the upper limit item.

SP
 TM The initial setup display shows 1000. However, since the decimal point position is the 2nd from the right, it is indicated as 100.0.

SP
 TM Press key.

SP
 TM Shift the flashing location of a digit by pressing this key.

SP
 TM Increase the flashing digit to 2 by pressing this key.

SP
 TM Press key.

8 Linear PV lower-limit

SP
 TM Initial setup display:
 0: -1999 to upper-limit U

9 Linear PV upper-limit

SP
 TM Initial setup display:
 1000: Lower-limit to 9999

(Example)
 Perform the following operation for setting the linear input to 0 to 200.0. (Example of [7], [8], [9] items)

SP
 TM The digit flashes when pressing key.

SP
 TM Increase the number to 1 by pressing this key.

SP
 TM Pressing key.

10 SP limit lower-limit _____

SP
 TM

The initial setup display shows 0% FS. This is the low end value of the range. (Depends upon range).

11 SP limit upper-limit _____

SP
 TM

The initial setup display shows 100% FS. This is the high end value of the range. (Depends upon range) (1200 in case of 0 to 1200°C range, for example).

- This item restricts the setting range of a program. If the temperature limit of an equipment is 600°C, for example, this item does not allow the equipment to be set to higher than 600°C, so that the equipment is protected or prevented from being set to be higher than the temperature limit, or, 800°C, for example, by mistake. The SP limit restricts the SP setting range in programming, and it is not effective for a preset SP, a running SP in which an SP bias is added, and a manual SP.

Since the digit of C 1 0 is 0, the lower-limit remains unchanged, but the upper-limit value is changed.

SP
 TM

By pressing the key, the digit flashes.

SP
 TM

Shift the flashing location of a digit by pressing this key.

Change the flashing digit to 6 by pressing these keys.

SP
 TM

Press key.

15 Type of auxiliary output _____

SP
 TM

Initial setup display:
 0: Specifies whether PV is set or not.

1: Specifies whether SP is specified or not.

16 Auxiliary output 4 mA setting _____

SP
 TM

Initial setup display shows 0% FS. It differs according to the type of PV range code.

17 Auxiliary output 20 mA setting _____

SP
 TM

Initial setup display shows 100% FS. It differs according to the type of PV range code.

(Example) , ,

When a PV value is an auxiliary output as 0 to 100 to a recorder.

SP
 TM

This digit remains unchanged. Proceed to the next item.

Press key for proceeding to the next item, "auxiliary output 4 mA setting".

SP
 TM

The digit flashes when pressing key.

SP
 TM

Shift the flashing location of a digit by pressing this key.

Change all digits to 0 by pressing these keys.

SP
 TM

Press key.

Press key for proceeding to the next item, "auxiliary output 20 mA setting".

SP
 TM

The digit flashes when pressing key.

SP
 TM

Shift the flashing location of a digit by pressing this key.

Change the value to 100 by pressing these keys.

SP
 TM

Press key.

Items 18 to 21 are used not to display unnecessary items so that the programming mode is free of items where setting is not changed usually.

Make unnecessary items not to be displayed by 18 to 21, because all items appear in initialization. (See the following table)

These items are not displayed, but the set points remain effective. Make sure again before setting these items that all set points are correct and their display is not necessary.

No. of cycles	Segment item	1	2	3	...	20
A	SP time	Upper display	SP			
		Lower display	Time			
B	Event No. 1	Upper display	(Goes out)			
		Lower display	Event set point			
C	Event No. 2	Upper display	(Goes out)			
		Lower display	Event set point			
D	Time event No. 1	Upper display	ON time			
		Lower display	OFF time			
E	Time event No. 2	Upper display	ON time			
		Lower display	OFF time			
F	Time event No. 3	Upper display	ON time			
		Lower display	OFF time			
G	Time event No. 4	Upper display	ON time			
		Lower display	OFF time			
H	PID group selection	Upper display				
		Lower display	Group No.			
I	G.SOAK setting	Upper display				
		Lower display				
J	PV start setting	Upper display				
		Lower display				
K	Cycle setting	Upper display				
		Lower display	Cycle			
L	Program link setting	Upper display				
		Lower display	Program No.			
M	PV shift setting	Upper display				
		Lower display	Shift value			

18 EV1, 2 programming

SP

TM

Initial setup display:
0: Displays the item.
1: Does not display the item.

19 T1 to T4 programming

SP

TM

Initial setup display:
0: Displays the item.
1: Does not display the item.

20 PID group, G.SOAK programming

SP

TM

Initial setup display:
0: Displays the item.
1: Does not display the item.

21 PV start, cycle programming

SP

TM

Initial setup display:
0: Displays the item.
1: Does not display the item.

(Example) 18, 19, 20, 21

When the display of the time events T1 to T4 is not required;

SP

TM

The digit flashes when pressing key.

SP

TM

→ Change the number to 1 by pressing this key.

SP

TM

Press key.

The shaded portion consisting of the line of every programming item and the row of every segment (see the table on page 28) is not displayed.

26 PV

SP

TM

Initial setup display:

0: Input signal from thermocouple, resistance thermometer bulb, or linear input sensor is processed as PV.

1: The same PV input as described above is not displayed as PV on the console.

2: The value of the 0% FS of the range is processed as PV, irrespective of the input from sensor. A PV overrange alarm is not indicated.

27 Time display

SP

TM

A time (TM) to be displayed in the RUN or HOLD mode is selectable.

0: Displays the residual time of a running segment by rounding down the portion below the selected time unit.

1: Displays the lapsed time from the running start by rounding down the portion below the selected time unit.

28 Alarm display _____

SP

TM

Initial setup display:

- 0: Displays an alarm.
Displays alarms sequentially, if two or more alarms occur concurrently.
- 1: Does not indicate any alarm.
An alarm condition can be read by means of communication.

29 Program time unit _____

SP

TM

Initial setup display
0: Hour, minute
1: Minute, second

Specifies either hour/minute unit or minute/second unit to set the program pattern time (TM) and time even on-off.

34 Constant value control selection _____

SP

TM

Initial setup display
0: Program operation mode
1: Constant value operation mode

Specifies either hour/minute unit or minute/second unit to set the program pattern time (TM) and time even on-off.

35 A/M selection _____

SP

TM

Initial setup display	
0: Normal selection	Bumpless output
1: Normal selection	Bumpless output
2: Switch selection	Bumpless output
3: Switch selection	Preset output

This item determines whether or not A/M is to be selected by a remote switch, and what kind of output is to be used at that time.

The switch used for the switch selection is input to the No. 26 terminal used normally for selecting the position of 10 in program selection. When this switch is turned OFF, "auto" is selected; when turned ON, "manual" is selected.

36 Preset manual output variable _____

SP

TM

Initial setup display

When the preset output variable is selected in C35, its value is set herein.

5.

PARAMETER MODE

General

Parameters are provided to decide constants as the program controller. The parameter code indicating an item is displayed in the upper display, while a setting value is displayed in the lower display.

The setting in this parameter mode is not necessary, if an initial value satisfies the required specifications.

Proceed to the programming mode on page 8 in such a case.

Display/ setting order	Codes	Parameter item	Selection or setting range	Initial value in display	Description
1	<i>P r t c</i>	Program protect	0: Not provided 1: Provided	<i>0</i>	
2	<i>F i l t</i>	PV filter constant	0.0 to 120.0 sec	<i>0.0</i>	Not displayed when PV=0% fixed in SET UP
3	<i>P b i R</i>	PV bias	-100 to 100 U	<i>0</i> (U)	
4	<i>S b i R</i>	SP bias	- 50 to 50%FS	<i>0</i> (U)	
5	<i>G.S.b d</i>	G.SOAK band	0 to 100U	<i>5</i> (U)	
6	<i>c y</i>	Time proportional Output cycle	5 to 120 sec (relay output model) 1 to 60 sec (voltage output model)	<i>10</i>	Displayed in 0D, 6D (time proportional) model, but not displayed in 5G (current output) model.
7	<i>o u t L</i>	MV change limit	0.0 to 100.0% (every 0.5 sec)	<i>100.0</i>	Not displayed, if main output of 5G (current output) is set (SP).
8	<i>d i f f</i>	ON/OFF control differential	0 to 100U	<i>5</i> (U)	Displayed in 0D, 6D (time proportional) model, but not displayed in 5G (current output) model.
9	<i>E t 1</i>	Event 1 type	0: PV (direct action) 1: PV (reverse action) 2: Deviation (direct action) 3: Deviation (reverse action) 4: RUN 5: READY 6: END	<i>0</i>	The relay turns to NO in PV direct action, and it turns to NC in PV reverse action.
10	<i>H Y S 1</i>	Event 1 hysteresis	0 to 100U	<i>5</i> (U)	Specifies an on-off differential of event.
11	<i>E t 2</i>	Event 2 type	0: PV (direct action) 1: PV (reverse action) 2: Deviation (direct action) 3: Deviation (reverse action) 4: RUN 5: READY 6: END	<i>0</i>	
12	<i>H Y S 2</i>	Event 2 hysteresis	0 to 100U	<i>5</i> (U)	
13	<i>A t</i>	Auto tuning selection	0: AT is not executed. 1: System 1 is executed by AT key. 2: System 2 is executed by AT key.		Displayed only when auto tuning is provided. Not displayed when SET UP C 12=1 is set.
14	<i>i o u t</i>	PID operation Initial manipulated variable	0.0~100.0		Not displayed when SET UP C 12=1 is set.
15	<i>r P i d</i>	PID operation initialize at advance	0: Operation is not initialized. 1: Operation is initialized.		

(1) Parameter mode setting procedure

Refer to the key operation on page 5. For the parameter mode contents, see page 19. This paragraph describes the operation procedure for the selected parameter items out of No.1 to 12.

Press **PARA** key first.

1 Program protect

SP **P r t c**
 TM **0** Initial parameter display:
 0: Does not protect any program.

Set the number in the lower display to 1 for protecting a program.

SP **P r t c**
 TM **0 0 0 0** The digit flashes when pressing
ENT key.

SP **P r t c**
 TM **1** Increase the number to 1
 by pressing this key.

SP **P r t c**
 TM **1** Press **ENT** key.

- (1) This item inhibits the reset of programmed data.
- (2) When selecting 1 "Protects a program" after programming, none of all program data can be reset until 0 "Does not protect any program" is selected.

2 PV filter constant

SP **F I L T**
 TM **0.0** Initial parameter display:
 0.0: 0.0 to 120.0 sec

PV filter effect:

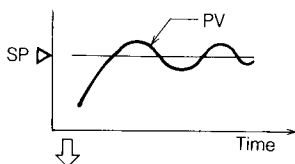

PV filter: Setting range
 0.0 to 120.0 sec

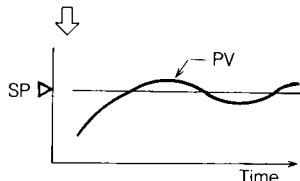

- (1) This item is used to set a PV filter constant.
- (2) The PV filter is used to filter the erratic input signal to the degree needed to get a stable. The filter effect increases as the numeric filter setting value increases.

3 PV bias

SP **P b i a**
 TM **0** Initial parameter display:
 0: -100 to 100U

PV bias effect:

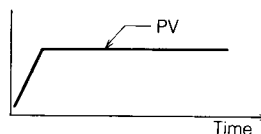

PV bias effect:

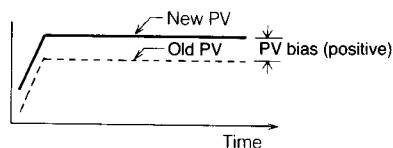

- (1) This item sets a PV bias value.
- (2) The PV bias is used to compensate for input such as the compensation of the drift of an input value due to deterioration of a sensor or other causes. A new PV value is obtained by adding a bias value.

5 G.SOAK band

SP **9.5.6 d**
 TM **5** Initial parameter display:
 5U: 0 to 100U

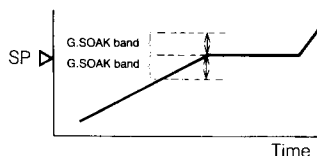

- (1) This item sets a G.SOAK band value.
- (2) G.SOAK shows the segment start point specified in programming, and the time is stopped until the absolute value of a deviation between PV and SP becomes smaller than the G.SOAK band.
- (3) G.SOAK is settable for every segment, irrespective of soaking, rising, or falling of segments.

6 Time proportional output cycle

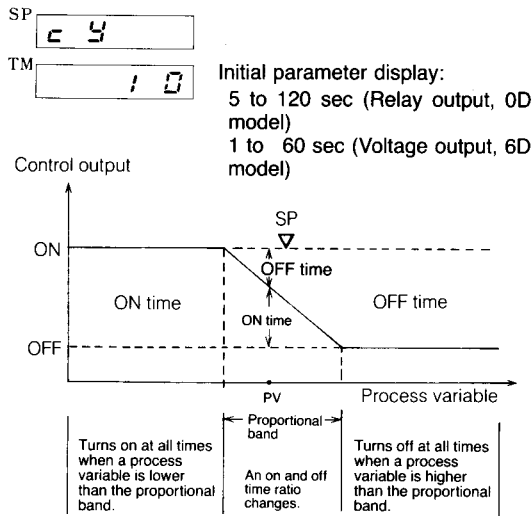

- (1) This item specifies the cycle time (control cycle) of the time proportional output.
- (2) If the cycle time (one cycle of on and off time) is set to 10 seconds, for example, the on time is 7 seconds when a process variable (PV) is lower than a set point (SP) in the proportional, and it becomes longer than off time (3 seconds).

7 Manipulated variable change limit

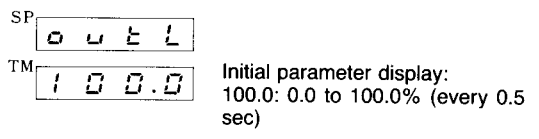

This item specifies the limit of a change quantity of the former arithmetic value and present arithmetic value of the control output.
 This limit is determined by the following calculation formulas.

- A=Former arithmetic value (%)
 - B=Present arithmetic value (%)
 - C=Manipulated variable change limit (%)
 - D=Actual output value (%)
- (Example 1) Assume that A+20, B=50 and C=20.

$$|B-A| = 50 - 20 = 30$$

$$\geq 20 = C$$

thus, $D = 20 + 20 = 40$

$D = A \pm C,$
 if $|B-A| \geq C$

(Example 2) Assume that A=20, B=50 and C=40.

$$|B-A| = 50 - 20 = 30$$

$$< 40 = C$$

thus, $D = 20 + 30 = 50$

$D = B,$
 if $|B-A| < C$

- (1) This item controls a control output change quantity.
- (2) The output arithmetic value is updated once every output update cycle 0.5 sec (twice every second). If the manipulated variable change quantity limit is 0.5%, an output is changeable 60% per minute.

8 on/off control differential

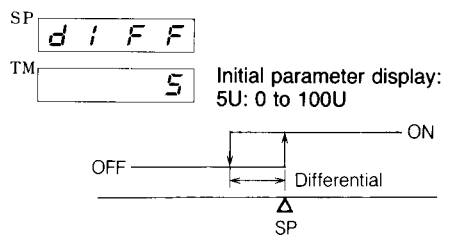

This item specifies the on/off control differential.

9 Event 1 type **10 Event 2 type**

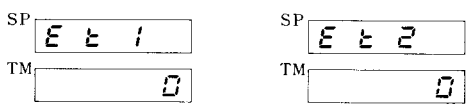

- Initial parameter 1
 0: PV direct action
 2: DEV (deviation) direct action
- Initial parameter 2
 1: PV reverse action
 3: DEV (deviation) reverse action

This item specifies whether an event is set to PV or DEV (deviation).

(Example) In case of PV event;

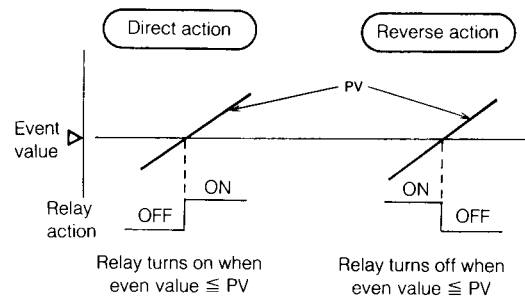

13 Auto tuning selection

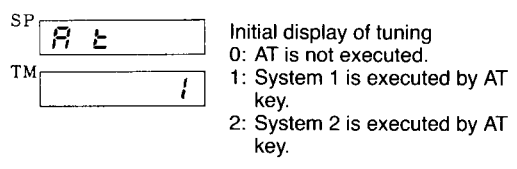

System 1 and System 2 of auto tuning are described below.

- 1: System 1 { The most popular control constants can be automatically set. When stress is placed on the arrival time to the set point, this system is used although a little overshoot may be produced.
- 2: System 2 { Used when an overshoot is liable to be enlarged as a device or an overshoot is to be suppressed especially. In many cases, the overshoot is suppressed, but therefore the rise tends to be delayed.

14 PID operation initialize

If the program starts when P≠0, PID operation begins with this numeric value.

(2) MAIN FUNCTION SETTING

Program pattern

Map position	Segment item	1	2	3	...	20
A	SP					
	Time					
	Upper display					
	Lower display					

Main function
(pattern data)

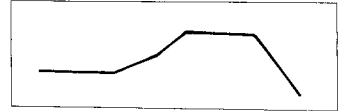

Subfunction
(events and other data)

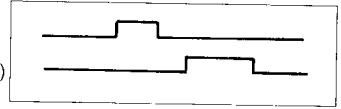

(3) PROGRAM PATTERN SETTING

Set point

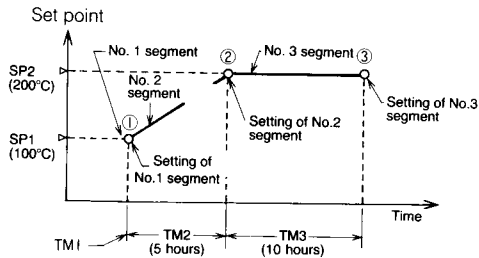

- (1) Set the basic program pattern.
 - (2) Prepare each segment (broken line) sequentially by assigning one point as shown in ①, ②, ③ in the left figure.
 - (3) Assign points ①, ②, ③ by combining SP (set points) and TM (time) switch each other.
 - (4) The unit of TM (time) is either hour/minute or minute/second, and it can be assigned by SET UP C29.
- Perform operation according to the assignment of C29 in the operation mode, irrespective of the assignment in the programming mode.

Segment No.	SP (Set point)	TM (time)	Description
1	100°C	0 hour	Start point designation. Soaking for 0 hour at 100°C
2	200°C	5 hours	Ramp segment designation. Heating for 5 hours up to 200°C
3	200°C	10 hours	Soaking segment designation. Soaking for 10 hours at 200°C

For setting the soaking segment, set the SP (set point) of the present point to the SP of the next point.

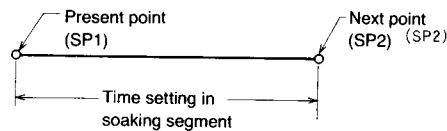

$$SP1 = SP2$$

For setting the ramp, make a differential between the SP (set point) at the present point and the SP at the next point.

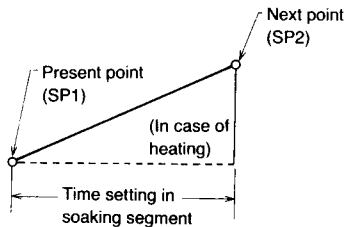

$$SP1 < SP2$$

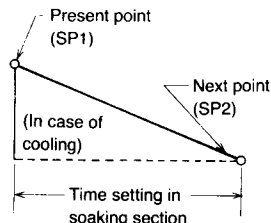



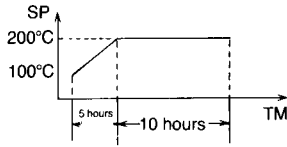



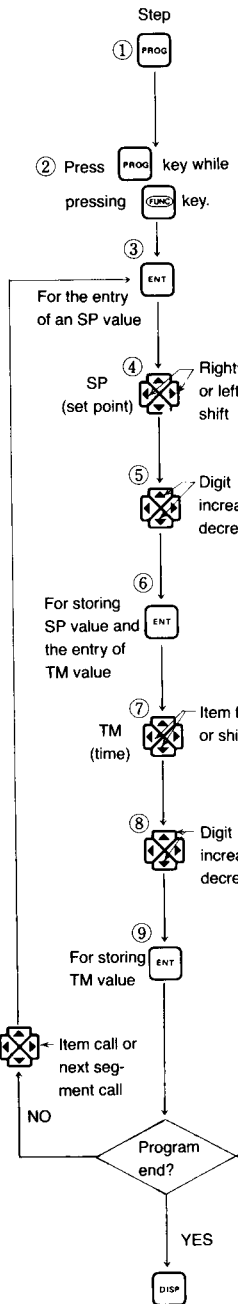

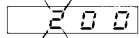
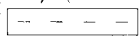

$$SP1 > SP2$$

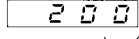
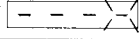

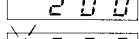
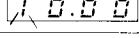

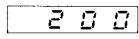
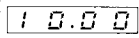
SP	Input range. Limit range when SP limit is set.
TM	0 to 99 hours 59 minutes

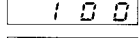
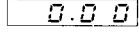

Map position	Key operation	Display	Description of display	Display of profile
A 1	Press PROG key.	PROG SEG 	Specifies program No. SP, TM, LED light.	
A 1	Press PROG key while pressing FUNC key.	SP: _ _ _ _ TM: _ _ _ _	Sets to programming mode. PRG LED lights. PROG SEG decimal points light.	
A 1	Press ENT key.	SP: _ _ _ _ TM: _ _ _ _	Segment 1 The last digit in SP display flashes. SP (set point) entry operation	
A 1	Press this key.	SP: 0 1 0 0 TM: _ _ _ _	Press this shift key (left), or continue pressing this shift key.	
A 1	Press this key.	SP: 0 1 0 0 TM: _ _ _ _	Increase the flashing digit by a digit increase key. Set SP=100(°C).	
A 1	Press ENT key.	SP: 1 0 0 TM: _ _ _ _	The last digit in TM display flashes. TM entry operation	
A 1	Press this key.	SP: 1 0 0 TM: 0 0 . 0 0	Under this condition because TM=0 (hour)	
A 1	Press ENT key.	SP: 1 0 0 TM: 0 . 0 0	SP=100°C/TM=0 (hour) stored.	
A 2	Press this key.	SP: _ _ _ _ TM: _ _ _ _	Segment 2 PROG SEG 1. 2.	
A 2	Press ENT key.	SP: _ _ _ _ TM: _ _ _ _	SP entry operation	
A 2	Repeat (4) to (5) steps	SP: 0 2 0 0 TM: _ _ _ _	Set SP=200(°C).	
A 2	Press ENT key.	SP: 2 0 0 TM: _ _ _ _	The last digit in TM display flashes. TM entry operation	
A 2	Repeat (7) to (8) steps	SP: 2 0 0 TM: 0 5 . 0 0	Set TM=5 (time).	
A 2	Press ENT key.	SP: 2 0 0 TM: 5 . 0 0	SP=200(°C)/TM=5 (hours) stored.	
A 3	Press this key.	SP: _ _ _ _ TM: _ _ _ _	Segment 3 PROG SEG 1. 3.	
A 3	Press ENT key.	SP: _ _ _ _ TM: _ _ _ _	SP entry operation	

Map position	Key operation	Display	Description of display	Display of profile
A 3	Repeat ④ to ⑤ steps	SP  TM 	Set SP=200(°C).	
A 3	Press  key.	SP  TM 	The first digit in TM display  flashes.	
A 3	Repeat ⑦ to ⑧ steps	SP  TM 	Set TM= 10 (hours).	
A 3	Press  key.	SP  TM 	SP=200°C/TM= 10 (hours) stored.	
—	Press  key.	SP  TM 	Programming mode ends.	

Press  key during the flashing of SP or TM data. If the  key is pressed while pressing  key instead of setting data, all program data after the segment is deleted. Therefore, if this operation is done at the first segment, the entire program data are deleted.

(4) SUBFUNCTION SETTING

Complete the program work sheet.

Map position	Segment	1	2	3	...	20
A	S P . T M					
B	E V 1					
C	E V 2					
L	Cycle setting					

Map position	Segment	1	2	3	...	20
B	EV1 event No.1					
C	EV2 event No.2					

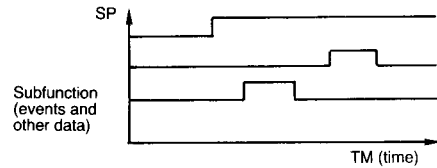
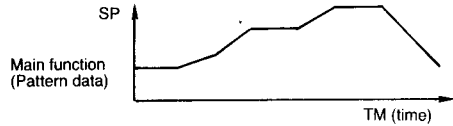

Whether EV1 and EV2 are used in PV event or DEV, whether the event action is done by direct action or reverse action, or which event is selected, RUN, READY, or END, is set by parameter mode 9 $\boxed{E \Delta 1}$ and 11 $\boxed{E \Delta 2}$.

1. PV-based event circuit setting:

The PV-based event circuit is operated by comparing a PV and an event set point with each other.

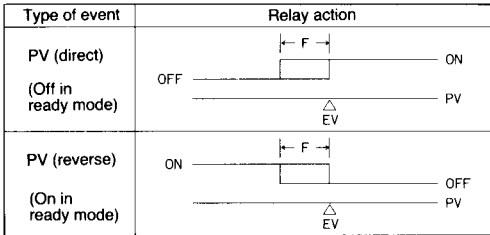

(RUN, READY, END events)
These events inform of the end of program operation, etc. No numerical setting is done.

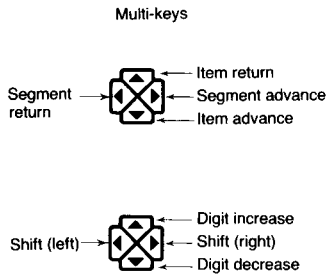
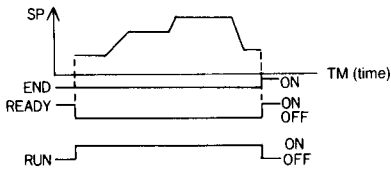

2. DEV-based event circuit setting:

The DEV-based event circuit is operated by comparing a deviation (PV-SP) and an event set point with each other.

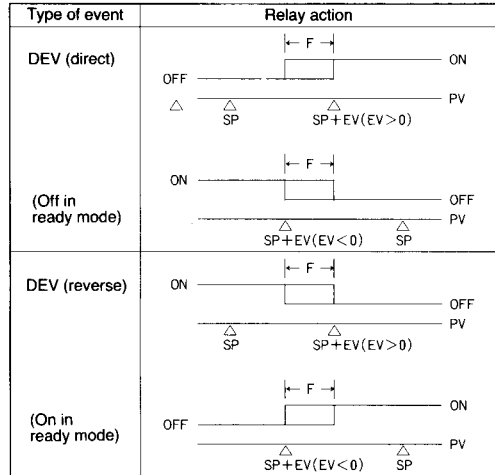

Map position	Keying operation	Display	Description
B 3	<ol style="list-style-type: none"> Press item advance key. Press segment advance key. 	<div style="border: 1px solid black; padding: 2px;">PV</div> <div style="border: 1px solid black; padding: 2px;">- - -</div>	Shifts to B3 position ① PRG, EV1, and PV of display light. ② Display segment (map B3) for event setting.
B 3	Press \boxed{ENT} key.	<div style="border: 1px solid black; padding: 2px;">PV</div> <div style="border: 1px solid black; padding: 2px;">- - - \times</div>	The first digit in a lower-display flashes.
B 3	<ol style="list-style-type: none"> Press shift key. Press digit increase key. 	<div style="border: 1px solid black; padding: 2px;">PV</div> <div style="border: 1px solid black; padding: 2px;">0 1 0 0</div>	Enter 100(°C).
B 3	Press \boxed{ENT} key.	<div style="border: 1px solid black; padding: 2px;">PV</div> <div style="border: 1px solid black; padding: 2px;">1 0 0</div>	Store PV event 100°C.

Setting range	
PV event	Input range
DEV event	0 to 50% FS of input range

(Note) Setting is deleted by pressing \boxed{CLR} key while pressing \boxed{ENT} key instead of \boxed{ENT} key.

3. Time-based event circuit setting:

Map position	Segment	1	2	3	...	20
D	T1 time event					
E	T2 time event					
F	T3 time event					
G	T4 time event					

Time-based event circuit turns on and off with the program time, irrespective of the control output. They are specified by the time from the start point of the set segment.

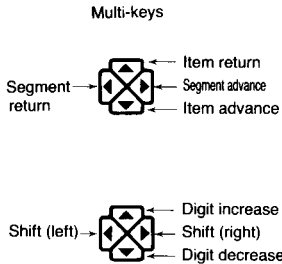
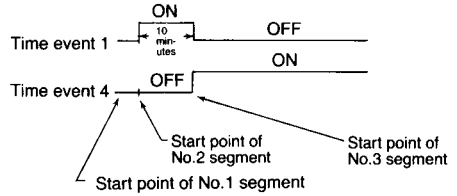
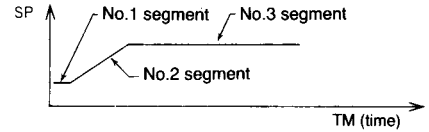

Map position	Key operation	Display	Description
D 2	① Press item advance key. ② Press segment advance key.	SP: [---] TM: [---]	Shift to D2 position ① RPG and T1 light. ② Display segment (map D2) for event setting.
D 2	Press [ENT] key.	SP: [---] [X] TM: [---]	Press [ENT] key the first digit in upper display flashes for ON time setting.
D 2	Press [1] key.	SP: [0.00] TM: [---]	Set the time to turn on (0:00 in this case).
D 2	Press [ENT] (Note) key.	SP: [0.00] TM: [---] [X]	Press [ENT] key the first digit in a lower display flashes for OFF time setting.
D 2	① Press the shift key (left). ② Press the numeric value increase key.	SP: [0.00] TM: [10.00]	Set the time to turn off (10:00 in this case).
D 2	Press [ENT] (Note) key.	SP: [0.00] TM: [10.00]	Time event 1 setting { ON: 0:00 OFF: 10:00

(Note) Setting is cancelled by pressing [CLR] key while pressing [ENT] key instead of pressing [ENT] key.

Setting item	Contents
Upper display	ON time
Lower display	OFF time

Setting range	
ON time	0:00 to 99:59
OFF time	0:00 to 99:59

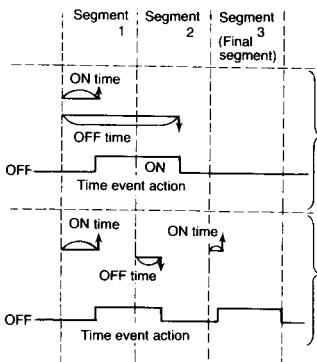

Example 1 In example 1, ON time and OFF time are set as one set at segment 1. Time event setting for a time exceeding the time of one segment is also possible.

Example 2 In example 2, the ON time only is set at segments 1 and 3, while the OFF time only is set at segment 2. ON and OFF can be set without combining ON and OFF time as one set. The time-based event circuit is turned off when the program ends.

4. PID group selection

Map position	Segment	1	2	3	20
H	PID group selection				

PID group No. to be employed in a segment is specified out of PID1, PID2, and PID3.

Set point	Contents
1	PID 1 group is used.
2	PID 2 group is used.
3	PID 3 group is used.

Multi-keys

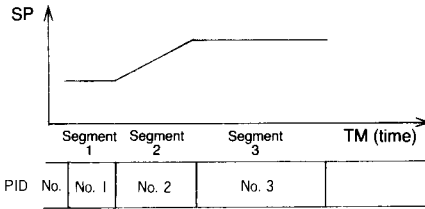
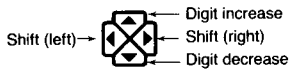

Map position	Key operation	Display	Description
H 2	① Press item advance key. ② Press segment advance key.	P i d 1	Shifts to H2 position. ① P i d . 1 is displayed in the upper display. ② Display the segment (map H2) for PID setting.
H 2	Press ENT key.	P i d 0 0 0 1	1 flickers in the lower display.
H 2	① Press digit increase key.	P i d 0 0 0 2	Increase the flashing digit to 2.
H 2	Press ENT key.	P i d 2	Store PID group No.2.

Note: PID values of each group are set by either PID tuning mode or AT action.

5. G.S (guarantee soak) setting

Map position	Segment	1	2	3	20
I	G.S setting				

Specify this item for setting G.SOAK (guarantee soak).

Setting item	Contents
YES	G.SOAK is set.
no	G.SOAK is not set.

Multi-keys

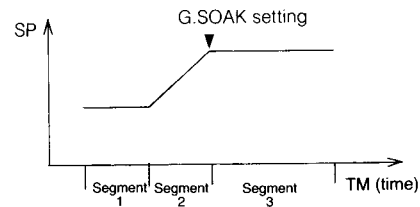
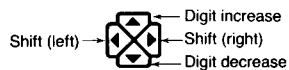
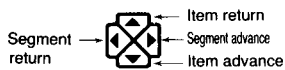

Map position	Key operation	Display	Description
I 3	① Press item advance key. ② Press segment advance key.	G . S . n o	Shifts to I3 position. ① LED lights. ② Display the segment (map I3) for G.SOAK setting.
I 3	Press ENT key.	G . S . n o	Press ENT key. n o flashes.
I 3	① Press item return key.	G . S . Y E S	YES flashes.
I 3	Press ENT key.	G . S . Y E S	YES is set.

6. PV start setting

Map position	Segment	1	2	3	20
J	PV start setting				

Specify this item for starting the program from the present PV.

Setting item	Contents
YES	PV start is executed.
no	PV start is not executed.

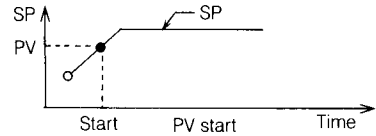
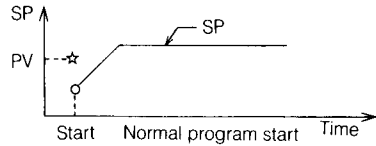

Multi-keys (nominal)

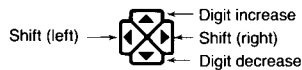
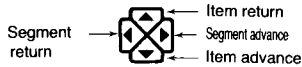

Map position	Keying operation	Display	Contents
J 1	① Press item advance key.	P.S t R no	Data are displayed in the upper display. (Note) YES or no of PV start can be set at any optional segment.
J 1	Press ENT key.	P.S t R no	no flashes.
J 1	① Press item return key.	P.S t R YES	YES flashes.
J 1	Press ENT key.	P.S t R YES	YES is set.

7. Cycle setting

Map position	Segment	1	2	3	20
K	Cycle setting				

Specify this item for executing the same program repeatedly.

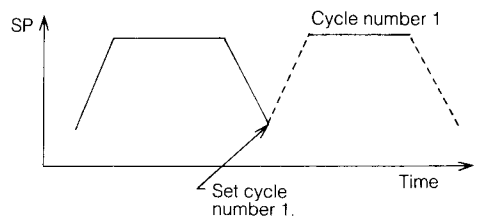

Multi-keys (nominal)

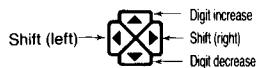

Map position	Key operation	Display	Description
K 3	① Press item advance key. ② Press segment advance key.	CYCL 0	Shifts to K3 position. ① CYCL 0 is displayed in the upper display. ② Cycle number can be set in any optional segment.
K 3	Press ENT key.	CYCL 0	Press ENT key, 0 flashes.
K 3	① Press the digit increase key.	CYCL 1	Assume that the cycle number is 1, set the digit to 1. 1 flashes.
K 3	Press ENT key.	CYCL 1	Cycle number 1 is set.

8. Program Link Setting

Map position	Segment	1	2	...	7	20
L	Program link destination setting					

This function is provided to link program data with each other. Set this program link every program data.

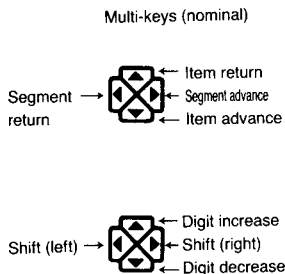
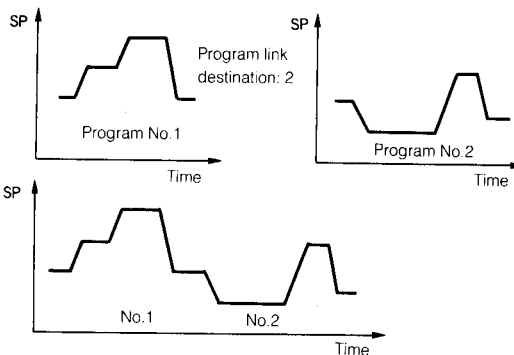

Map position	Keying operation	Display	Contents
L 1	① Press item advance key.	P.L I n 0	Data are displayed. Note: Program link can be set at any optional segment.
L 1	Press key.	P.L I n 0 0 0 0	0 flickers in the lower display.
L 1	① Press item return key.	P.L I n 0 0 0 2	Enter numeric 2.
L 1	Press key.	P.L I n 2	Set program link destination 2.

9. PV shift Setting

Map position	Segment	1	2	3	...	20
M	Program link destination setting					

The PV shift function is provided to set a PV correction value every segment.

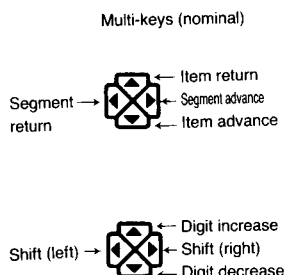
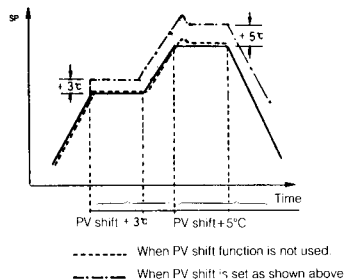

Map position	Keying operation	Display	Contents
3	① Press item advance key. ② Press segment advance key.	S H F t - - - -	Shifts to M2 position. Displays the segment (map M2) PRG display.
3	Press key.	S H F t - - - -	Y flickers in the lower display.
3	① Press digit increase key.	S H F t 0 0 0 3	Enter +3(°C).
3	Press key.	S H F t 3	Sets PV shift value 3°C.

Note: Setting is erased by pressing key while pressing key instead of pressing key.

General

Specify and set P (proportional band), I (integral time), D (derivative time), and the upper-limit and lower-limit of manipulated variables as PID constants according to the process.

A maximum of 9 PID groups can be set.

The PID key items constitute a matrix as shown in the figure below, and any item can be selected by moving up and down, or left and right, using the multi-keys ().

The PID key has the same moving function as in the downward key. The connection set by moving is indicated in the relevant number of 1 to 15 given outside the figure below. If display and setting are disabled, "----" is indicated on the lower display.

CAUTION:

When the DCP216 is used as a program setting device at the setting of Setup Mode C 12: 1 (for SP output), PID do not function.

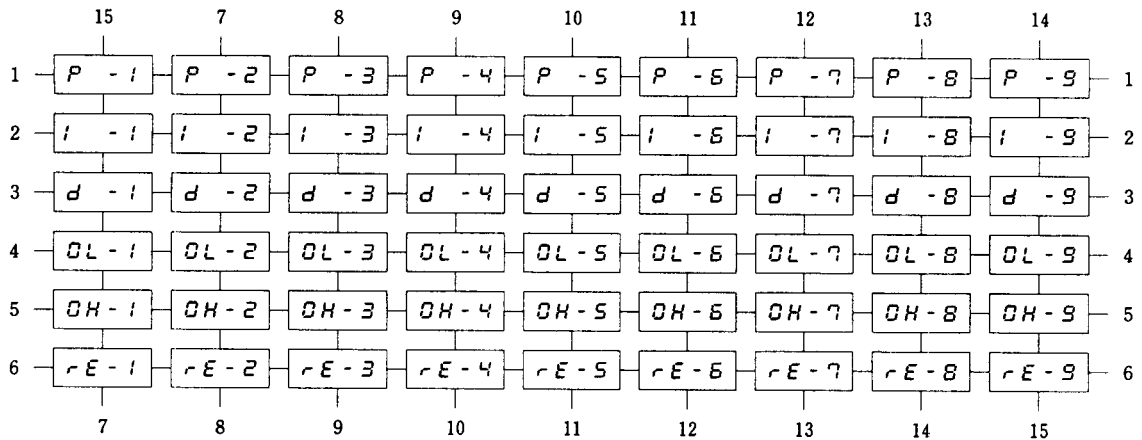

Display/ setting order	Code	Tuning item	Selection or setting range	Initial value in display	Description
1	P - 1	Proportional band 1	0.0 to 999.9% (time proportional) type 0.1 to 999.9% (current output) type	100.0	
2	I - 1	Integral time 1	0 to 3600 sec	0	Displayed when P≠0.
3	D - 1	Derivative time 1	0 to 1200 sec	0	Displayed when P≠0.
4	OL - 1	MV lower-limit 1	0.0 to upper-limit % (time proportional) type, -10.0 to upper-limit % (current output) type	0.0 -10.0	Displayed when P≠0.
5	OH - 1	MV upper-limit 1	Lower-limit to 100.0% (time proportional) type Lower-limit to 110.0% (current output) type	100.0 110.0	Displayed when P≠0.
6	rE - 1	Manual reset 1	0.0 to 100.0%	50.0	Displayed when P≠0 and I=0.

(1) PID tuning procedure

1 Proportional band 1

SP P - 1
 TM 1 0 0 . 0 Initial tuning display

2 Integral time 1

SP I - 1
 TM 0 Initial tuning display

3 Derivative time 2

SP d - 1
 TM 0 Initial tuning display

Setting range:
 $P-1, P-2, P-3$: 0.0 to 999.9% (time proportional type)
 : 0.1 to 999.9% (current output type)
 $I-1, I-2, I-3$: 0 to 3600 sec
 $d-1, d-2, d-3$: 0 to 1200 sec

P: This constant determines the deviation ratio of a measured temperature to a set point of a temperature, where the control output is to be set to 0 or 100. This value is set by % to a span of input range, and an about 10% is generally used for electric furnaces. As this range becomes narrower, the sensitivity becomes higher. However, if the range is extremely narrow, an undulation phenomenon occurs.

I and D: Unlike in on/off action, the P control action does not easily produce any undulation phenomenon. However, it is possible that the temperature remains deviated from a set point. I and D control actions are provided for preventing such a failure. In electric furnaces, I is generally set to 150 sec, while D is generally set to about 30 sec. As I becomes shorter, or as D becomes longer, the control function becomes stronger. However, when the control action is too strong, it may not be ensured that the control is executed satisfactorily at all times. Both I and D are off at 0.

4 MV lower-limit 1

SP o L - 1
 TM 0 . 0 Initial tuning display

5 MV upper-limit 1

SP o H - 1
 TM 1 0 0 . 0 Initial tuning display

Setting range

$oL-1, oL-2, oL-3$: 0.0 to upper-limit %
 (Time proportional type)
 -10.0 to upper-limit %
 (Current output type)

$oH-1, oH-2, oH-3$: Lower-limit to 100.0%
 (Time proportional type)
 Lower-limit to 110.0%
 (Current output type)

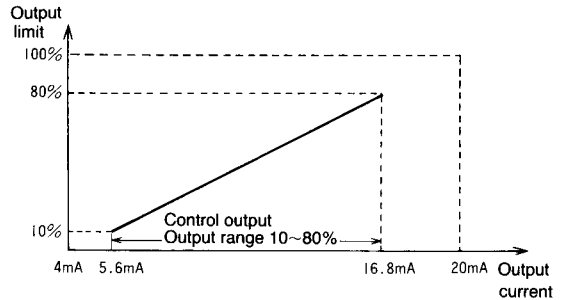

(Examples)

In case of 10% proportional band in 0° to 800° range.

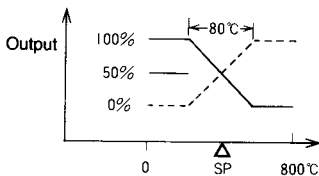

If I is short (strong), the control may often become excessive.

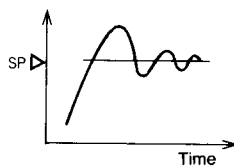







7. OPERATION MODE IN PROGRAM OPERATION

Program operation mode (Check if 0 is set in the setup mode.)

Check and set the following items before starting the program.

1. Is PV start executed?
See page 13, 28.
2. Is auto tuning executed?
See page 30, 31.
3. Are PID constants set? Is the output limiter set?
See page 27, 30.
4. Is PV bias used?
See page 19, 20.
5. Is SP bias used?
See page 19.
6. Is PV filter used?
See page 19, 20.
7. Is the MV change quantity limit set?
See page 19, 21.
8. Is the program protect function provided?
See page 19, 20.

Key operation

-  : Specifies the program number.
 -  : Change the mode from ready to RUN or from RUN to HOLD.
 -  : Specifies the display contents of the upper-display and lower-display.
- * For resetting to the ready mode (from RUN or HOLD), press  key while pressing  key.
- * For advancing the segment by one under RUN/HOLD mode, press  key while pressing  key.

Monitoring during program run

1. The program number and segment number display contents are as shown below during run and programming check.

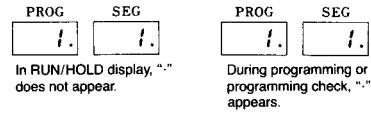

2. When  key is pressed, the upper- and lower-display indicator lamps indicate the contents of both upper- and lower-display by their combinations. The upper- and lower-display indication lamps are combined with each other as follows.

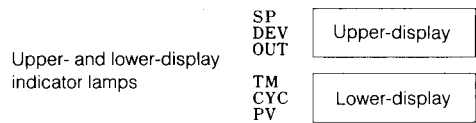

Combinations of upper- and lower-display indicator lamps

Upper-display	SP	DEV	OUT	TM	CYC	SP
Lower-display	PV	PV	PV	PV	PV	TM

3. Mode indication by mode indicator LED lamps

RUN: Lights during run.
 HLD: Lights during hold.
 MAN: Lights in manual operation mode.
 PRG: Lights in programming mode.
 (Note) None of mode indicator lamps lights under the ready mode.

4. Running pattern conditions, easily monitorable by profile indicator LED lamps

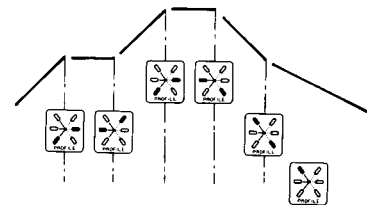

Program status display:

- Indicates rising, soaking, and falling tendencies of program pattern.
 - Indicates the present segment and next segment.
5. For identifying pattern which has already set or not, check if the upper-display shows the following contents when a program number is entered by  key.

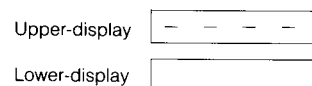

< OPERATION EXAMPLES >

1 Starting program

Specify the PV start Δ in programming. See page 35.

When PV start is set to Δ in programming, the normal start is done.

When PV start is set to Δ in programming, the PV start is done.

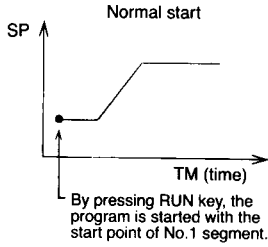

Display	Key operation	Description of contents
	Press key. (key)	Specify a program No. Press this key by necessary times. (The program No. can be returned stepwise by key.)
	Press key.	Runs. •RUN LED lights. •PROFILE LED lights.

2 Starting a program from a preset temperature

Specify PV start Δ in programming. See page 35.

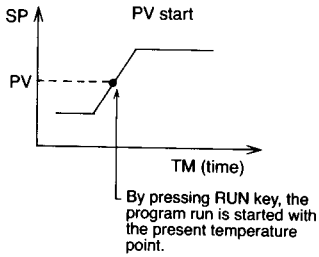

Display	Key operation	Description of contents
	Press key. (key)	Specify a program No. Press this key by necessary times. (The program No. can be returned stepwise by key.)
	Press key.	Runs. •RUN LED lights.

3 Holding a program

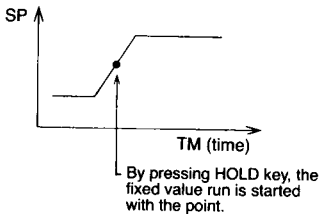

Display	Key operation	Description of contents
	Press key.	Holds. •HOLD LED lights.

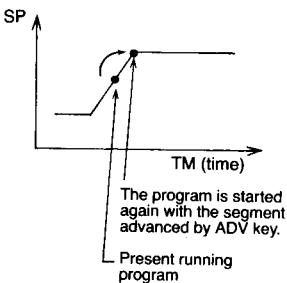

4 Advancing a program to a new segment

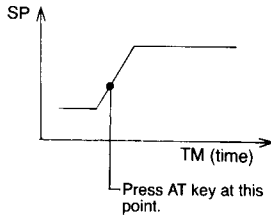

Display	Key operation	Description of contents
		Running.
	Press key while pressing key.	Perform ADV operation. The program proceeds to the start point of the next segment.

5 Starting auto tuning



Display	Key operation	Description of contents
PROG 1 SEG 2 SP 150  PV 4.00		During RUN or HOLD.
PROG 1 SEG 2 SP 150  PV 4.00	Press AT key.	Auto tuning is started. •AT LED lights.
		Auto tuning ends automatically.

Description of auto tuning (AT) (option)

• Auto tuning is executed only when all the following conditions are satisfied.

- ① RUN or HOLD mode
- ② AUTO mode
- ③ PID constant is set to "1" or "2".
- ④ PV is within the range.

• When auto tuning ends, the PID group constants used for the segment are replaced with new constants by auto tuning.

• For stopping this auto tuning, press **AT** key during auto tuning. The auto tuning stops, and PID constants are not rewritten.

Auto tuning method:

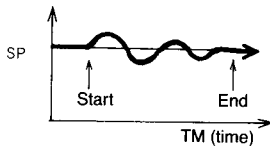

The on-off operation is repeated twice at about the set point of a temperature, and PID values newly calculated are used.

Whether the first control action is on or off depends upon the condition of PV and SP at that time.

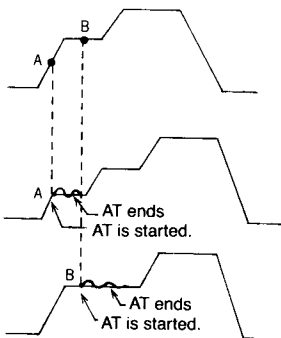

Auto tuning at point A



Be careful because a stepwise pattern appears halfway in the course of ramp.

Auto tuning at point B

The program automatically stops advancing temporarily when executing auto tuning.

It is automatically restarted after the end of auto tuning.

6 Selecting manual control for the process

Display	Key operation	Description of contents
 OUT 2.00 PV 2.00	Press A/M key.	Upper-display for main output (MV or SP). Lower-display for PV.
	Press  key.	MV or SP change Set an output value by multi-keys. The value is effective, even if ENT key is not pressed.

Press **A/M** key when returning to the automatic operation mode.

7 Stopping a program

Display	Key operation	Description of contents
<p>SP 2.00 PV 2.00</p>		Running
<p>SP 2.00 PV 2.00</p>	Press key while pressing key.	Program is reset to the ready mode. •RUN and HLD LEDs are off.



8 Copying stored program data under a different program number



Display	Key operation	Description of contents
<p>PROG 1 SEG 1 SP 1.00 TM 0.00</p>	Press key. (key)	Select a program number of the copy source by PROG key in an AUTO mode. (Returns stepwise by pressing key.)
<p>PROG 1 SEG 1 SP COPY TM ----</p>	Press key while pressing this key.	COPY is indicated on the upper-display, and ---- is indicated on the lower-display. No display appears, if the copy source is not available.
<p>PROG 1 SEG 1 SP COPY TM 0003</p>	Press this key. (In case of stepwise return)	Select a program number in the lower-display program number is not displayed if some program is set already for the number.
<p>PROG 1 SEG 1 SP COPY TM 3</p>	Press key.	Press ENT key to copy the program. However, it is not copied, if the total number of preset events of the instrument exceeds 200, the lower-display indicates ----.
	Press key.	Returns to the ready mode.

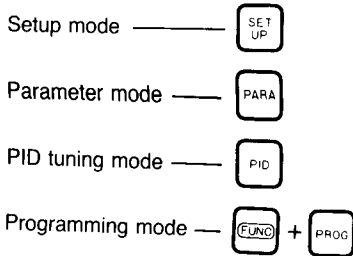

9 Changing program data

Select the mode to be corrected.







Select an item to be corrected by  keys, and press  key.

Change program data by  keys, and press  key.

A change of programming mode  + 

- The programming mode can be changed in RUN/HOLD or READY mode.

By pressing  +  keys in the programming mode, data can be changed, starting with SEG1 of the next program data.

The program No. is returned stepwise by  + .

- After change, the display is reset to the original one by  key.

[Caution]

The soak SP is changed as illustrated below, if changed halfway in the course of operation.

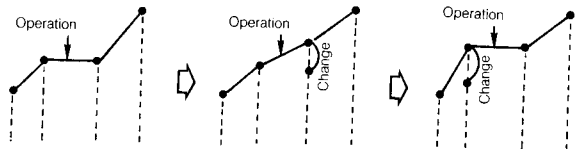





For changing the soak temperature, the SP must be changed twice. For changing the soak SP, the SP must be changed twice at the soak start point and end point. (See page 22.)

10 Storing the setting range limits of a program

C10 : Lower-limit value
C11 : Upper-limit value

Setup mode.

Select *C10* or *C11* by  or  keys, and press  key.

Change the program data by  keys, and press  key.

11 Deleting stored data



Set the ready mode.

 +  in RUN/HOLD mode.

 in MANUAL mode.



 in other cases.

Select the program No. of the program to be deleted by  key.

Select the programming mode by pressing  key while pressing  key.

Display the values of SP (set point) and TM (time) of segment 1 by  keys.

Start changing the values of SP or TM by  key to flash the value.

The program can be deleted by pressing  key while pressing  key.

12 Alarm code display

If a PV alarm or an instrument alarm is detected, a program segment No and its alarm code are displayed on the PROG/SEG indicator alternately every second, but the instrument run and other action are continued. However, if A90 alarm occurs, its alarm code only is continuously displayed on the PROG/SEG indicator, and the lower-stage indicator displays the present board input/output and option type. The instrument does not start any action.

Alarm code	Meanings	Remedial measures
RL 01	PV is not within a range of -10 to 110% FS.	Check the sensor/disconnection.
RL 90	PC board is not properly mounted. (Check it only when power is turned on.)	Ask for repair.
RL 92	EEPROM is defective.	Ask for repair.
RL 94	SETUP and PARA parameter contents were broken.	Reset.
RL 95	PID parameter contents were broken.	
RL 96	Program pattern contents were broken.	
RL 98	RAM is defective.	Ask for repair.
RL 99	ROM is defective.	

13 Condition (of the DCP216) after recovery from a power failure

- A power failure to the DCP216 will occur when its power supply drops below 70V AC and remains below this level for longer than 100 msec.
- After sufficient power has been generated, all functions of the instrument will return to conditions existing before the failure, i.e. the display mode will continue operations from the point immediately before the failure. Operating time will also progress from the point immediately before the failure.
However, the LED display and the EVENT operation will only reappear two to three seconds after sufficient power has been generated; upon reactivation, their timing will not coincide with the other operations' timing.

14 Read conditions

- Control output condition: 0% output (control output code 5G indicates 4mA; 0D and 6D mean off)
- SP output (when the main output is set to SP by 5G) condition: Output corresponding to the lower-limit of the PV range.
- Event output condition: off when set to direct action with parameter, and on when set to reverse action with parameter.
- Time event output condition: off
- Display condition: Both RUN and HOLD LET's off.
- PID operation: Not operated.
- Auxiliary output condition: Same as in running. However, the lower-limit of PV range, when set to the SP output.
- Others: Setup setting possible.

8.

REMOTE OPERATION

1. Remote operation

RUN, HOLD, RESET, and other operations can be done by using external contacts. An automatic operation of the DC 216 can be made by combining this remote operation function with a sequencer.

In case the operation 3 mode is selected (C37=0)

When C35=0 or 1,
operation 3 mode (RUN, HOLD, RESET)
+ 19 patterns selection

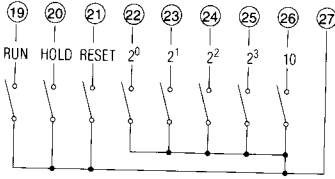

When C35=2 or 3,
operation 3 mode (RUN, HOLD, RESET)
+ AUTO/MANUAL selection + 15 patterns selection

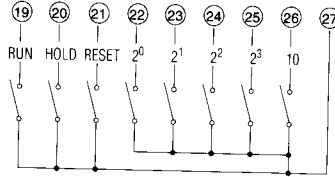

Program number selection, A/M changeover: Status signal
RUN, HOLD, RESET: Pulse signal

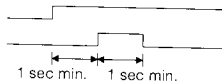

In case the operation 4 mode is selected (C37=1)

When C35=0 or 1,
operation 4 mode (RESET, RUN, HOLD, ADV)
+ 19 patterns selection

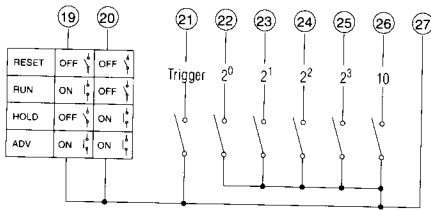

When C35=2 or 3,
operation 4 mode (RUN, HOLD, RESET, ADV)
+ AUTO/MANUAL selection + 15 patterns selection

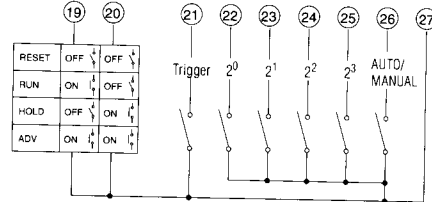

An operation mode can be selected by designating RESET, RUN, HOLD, or ADV through terminal No. 19 and 20, and inputting an OFF to ON trigger to terminal No. 21.

RESET

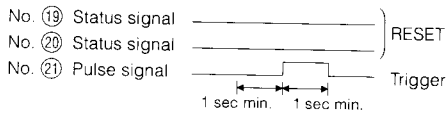

HOLD

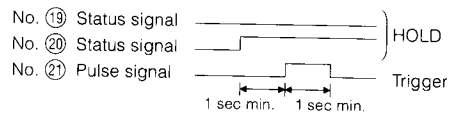

RUN

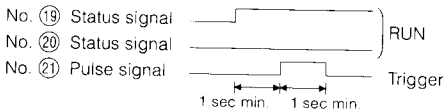

ADV

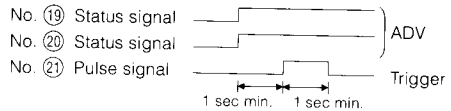

2. Description of Remote Operation

1) Remote RUN operation

If a program specified by four or five program No. switches has already been programmed when none of setting operations (programming, PID, PARA, SETUP) is done in the READY mode, the program starts running.

The program runs continuously from the HOLD point in the HOLD mode regardless of setting operation. (The program number of the program to be run remains unchanged even if the specified program number differs from the running program number.)

2) Remote HOLD operation

The program is set to the HOLD mode during run regardless of execution of setting operations.

3) Remote RESET operation

The program is set to the READY mode (waiting for run) in the RUN or HOLD mode regardless of execution of setting operations.

4) Remote program number selection

Select a program number (No. 1 to 19) by four or five switches in remote operation in the READY mode.

Program No. 0 with all the program No. switches turned off means the designation of a program which has already been selected by the console.

5) A/M changeover selection

When the code C35 of A/M changeover selection is set to switch selection, the terminal normally used to select the '10' place of program number is used for A/M selection instead. When the switch connected to this terminal is turned off, the automatic operation is selected; when it is turned on, the manual operation is selected.

The program selectable function is then limited only to a maximum of 15 patterns. Setting of SETUP key lock does not affect any remote operation.

An example of connection terminals for program No. selection

Program No.	Terminal connection
1	(27)-(22)
2	(27)-(23)
3	(27)-(22), (27)-(23)
7	(27)-(22), (27)-(23), (27)-(24)
10	(27)-(26), (27)-(23), (27)-(25)
11	(27)-(22), (27)-(26)
19	(27)-(22), (27)-(25), (27)-(26)

(Note) There are two kinds of selecting Tmethods for No. 10 to 15.

1. Main function

(1) SOAK SEGMENT

- The soak means a section where SP is kept constant irrespective of the lapse of time.
- A program is set by specifying a set point and time of each segment. It is set by specifying an aimed set point in the segment and the time required to arrive at the aimed set point.

If the set point of the former segment is equal to that of the present segment in the program mode, the soak is set, and its time is set by the present segment time.

A set point and time of the first segment (segment No.1) of a program are set to soak at all times. If the time is set to zero, the set point becomes a point.

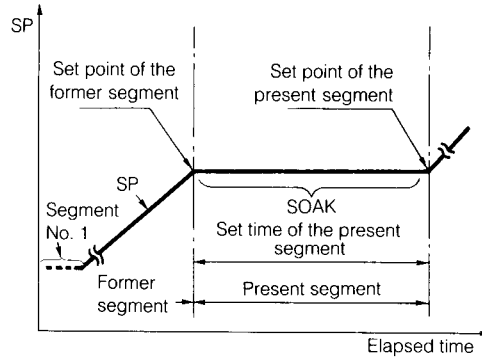

(2) RAMP SEGMENT

- The ramp means a section where a set point changes at a constant ratio with time.
- The first segment (segment No.1) of a program cannot be set to any ramp segment.

The ramp angle α is obtained by dividing a difference between set point SP1 of the former segment and set point SP2 of the present segment by the preset set time in the programming mode.

- Set the segment No.1 time to 0:00 for starting the operation with RAMP segment.

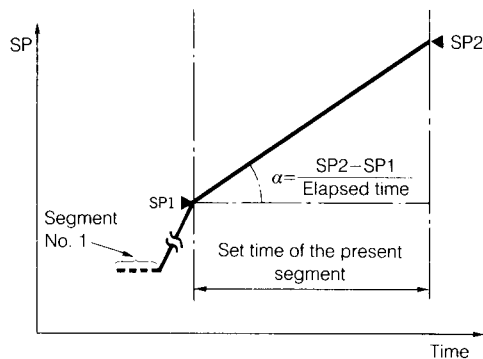

(3) RUN, READY, and END events

- These events are used for outputting an operation signal and an operation end signal to the outside.
- RUN event: Turns on in RUN/HOLD mode, and turns off in READY mode.
- READY event: Turns off in RUN/HOLD mode and turns off in READY mode.
- END event: Turns on after the program operation ends and turns off by remote or communication RE-SET operation or in RUN/HOLD mode.

1. Set EV1 and EV2 to display the program item in the setup mode.
2. In parameter mode;
 - RUN, READY, END event of even 1
 - ... 4 RUN setting
 - 5 READY setting
 - 6 END setting
 - RUN, READY, END event of event 2
 - ... 4 RUN setting
 - 5 READY setting
 - 6 END setting

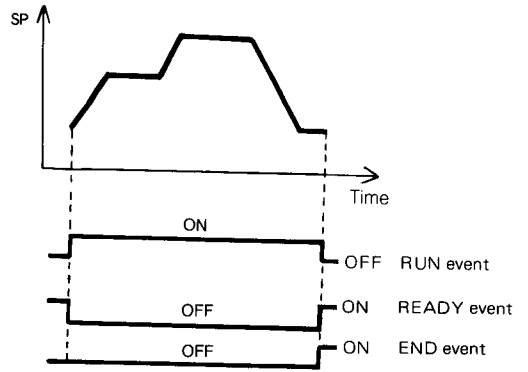

(4) Time-based event circuits

- This time event circuit is a 4-channel transistor open collector output, and it turns on and off according to the lapse of the program time.
- The time event is settable in any segment. The on/off operation of each channel can be set by the time from the start point of the segment or the time exceeding the segment time can also be set. (If the time is set in excess of the final segment, the program is in READY mode after the program end, and the output turns off.)
- The ON and OFF action can be set once in one segment for each channel. Either on or off action only is also settable.
- The ON or OFF action is set independently each other.
- If the same setting (ON setting if the ON action is in progress, or OFF setting if the OFF action is in progress) is set in a subsequent segment again, the former setting becomes ineffective, while the latter setting becomes effective.
- The right figure No. ① shows that either A or B method is used to set the event output for the time event crossing a segment.
- The right figures ②, ③, ④, and ⑤ show the examples of the event output that the present time event is newly set to the former time event.
- Time event timer stops in HOLD mode.
- The switching point of two segments is regarded to belong to the latter segment.
- The time event is off in READY mode.

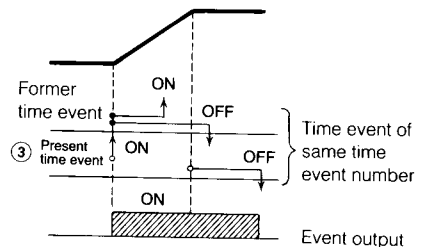
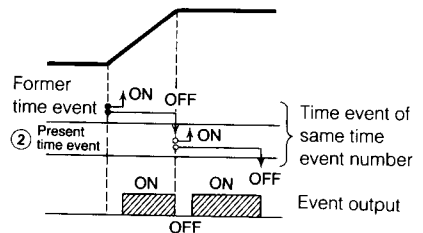
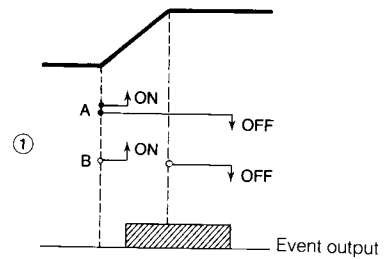
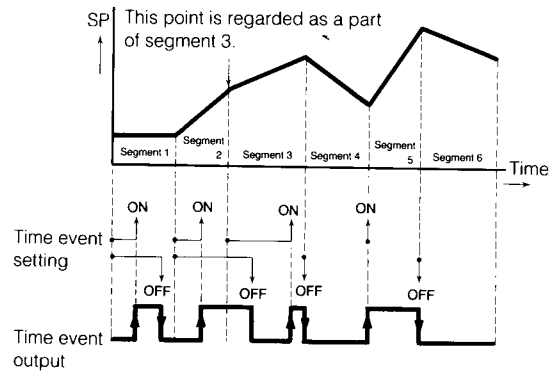

1. Set the time event in setup mode to the item to be displayed at the programming.
2. Set the ON time and OFF time of the time event in each segment in the programming mode.

- When a segment is advanced to the next segment by the segment advance operation, the timer of the time event is corrected so that the same results can be obtained as in normal advance to the next segment without segment advance operation.

- If a power failure occurred, the time event is continued after recovery from the state just before the occurrence of the power failure.

- The time event turns off momentarily at the cycle switching point when cycle action is applied.

- When a program is transferred to segment 01 by cycle action, the time event setting and timer are cleared once, and they are reset and corrected to the same results as in normal start of the program with segment 01.

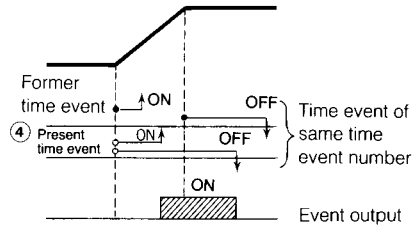

(Caution) It is impossible to execute two-ON and one-OFF setting operation in the same segment.

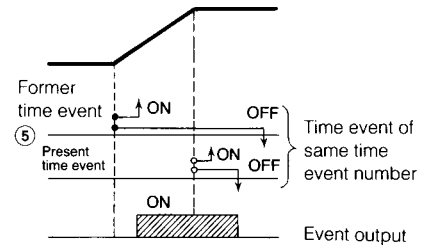

Time event in PV start

If a program is started halfway in the course of a certain segment by the PV start operation, the time event setting and timer action are executed to be the same results as in the transfer to the halfway (the point found by the PV start) of the segment by normal start with segment 01 without PV start operation.

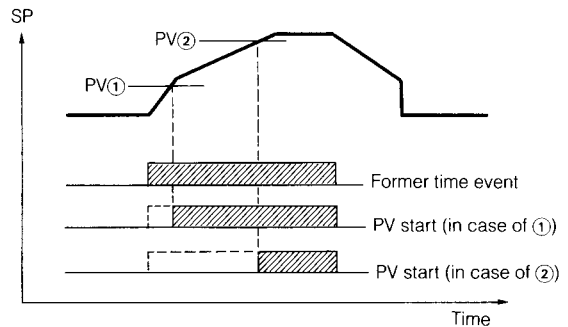

The time event at PV start is automatically corrected.

Time event in guaranteed soak

The time event circuit turns on simultaneously when an SP enters the guarantee soak segment of a program when the ON time is "0", and the time measurement stops until the PV reaches the guaranteed soak temperature band. The time measurement is started with the time the PV has reached the guaranteed soak temperature band. Thus, the time compensation of the guaranteed soak segment can be synchronized with the time event time.

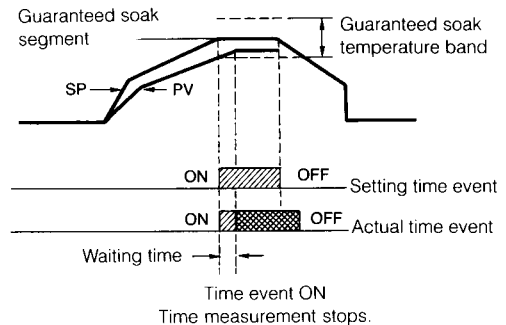

(5) PID group selection

- Three groups of PID parameters can be used for control operation, assuming that one group consists of P.I.D. and output limiters.
- A PID parameter group to be used for each segment is selectable during programming.
- PID groups are assignable in any segment.

1. Set PID in setup mode to the item to be displayed at the programming.
2. Set a PID group to be used in the programming mode.

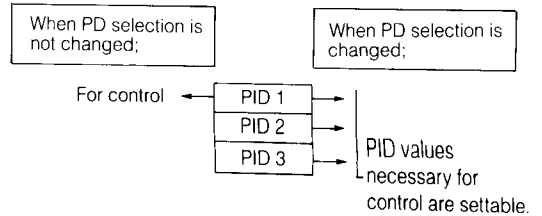

- One group of PID constant groups is selected at the delivery from factory.

(6) G.SOAK (guaranteed soak)

- The guaranteed soak means a section where the segment setting time is guaranteed without starting the segment setting time count until PV enters a predetermined band of SP.
- The G.SOAK time is started counting after a PV value has entered the soak band for more than one second. This is also applicable to the advance mode.
- Unlike events, the action is judged at the entry of the segment in which G.SOAK is set. This decision is irrespective of whether a PV value gets out of the G.SOAK band or not after it has entered the G.SOAK band once. This G.SOAK can also be set at the RAMP segment point. The action is judged at the entry of a RAMP segment in the same way as described above, and it is not executed during the RAMP segment time until PV enters a certain band of SP.

1. Set G.SOAK in the setup mode to the item to be displayed at the programming.
2. Set the G.SOAK band (numeric value) in the parameter mode.
3. Set whether G.SOAK is used or not in each segment of the programming mode.

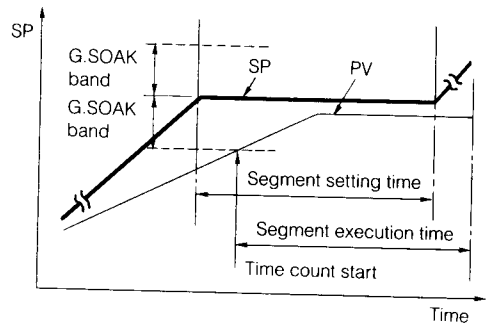
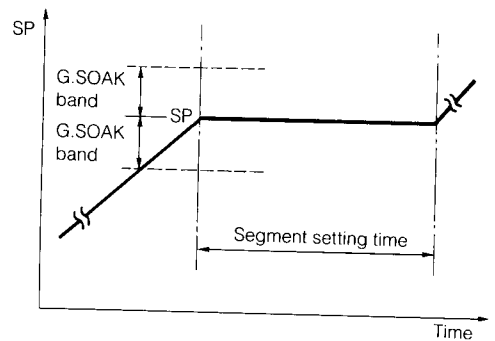

(7) PV start

Operation start from a PV value point on a program pattern

PV start function

- The PV start is made by normal RUN operation, if the PV start is set during programming.
- A program is started with the first point where the PV coincides with the SP of the program (PV and SP include a bias).
- A program is started with the beginning of No.1 segment, if PV and SP don't coincide with each other.
- After PV start, the event action and time event time are automatically corrected.

1. Set the PV start in the setup mode to the item to be displayed at the programming.
2. Set YES or NO to determine whether the program is PV started or not in the programming mode.

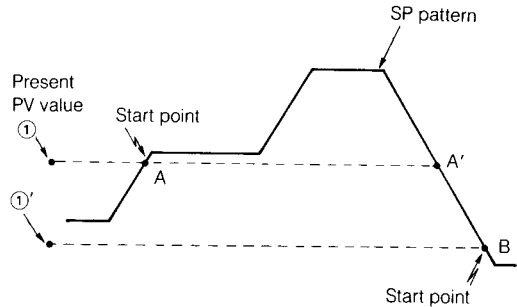

PV start point

- ① A program is started with the point (A) where a PV value coincides with an SP pattern first.
- ①' Since the point (B) where a PV value coincides with an SP pattern first is positioned at the end of this program, the residual pattern only is program-controlled.

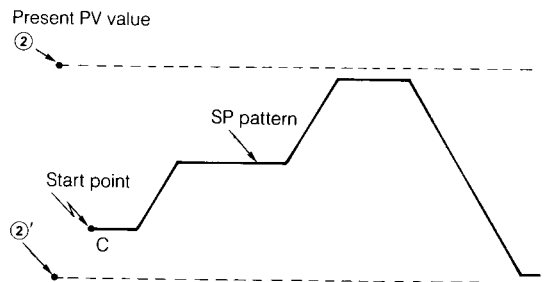

PV start point

- ②, ②' Since a PV value and an SP pattern don't coincide with each other, a program pattern is started with No.1 segment (C).

(8) Automatic cycling of a program

- This function repeats the program from No.1 segment of a complete program to the final segment by the number of preset cycles. The number of cycles is settable to max. 99 cycles every program.
- If No. of cycles is set to n, the program is repeated by n+1 times.
- Cycle run is restarted under the cleared condition of each event setting of PV, DEV, and time without running at the end point of the final segment.
- This run is started with segment 1 without executing any PV start, even if the PV start function is preset.

1. Set No. of cycles in the setup mode to the item to be displayed at the programming.
2. Set No. of cycles in the programming mode.

If the program start point SP and end point SP don't coincide with each other, the SP changes stepwise in cycle operation.

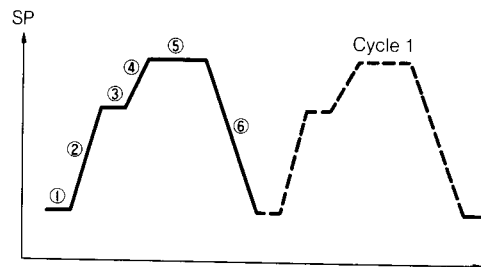

- No. of cycles to repeat the entire program can be set from any segment (① to ⑥).
- No. of cycles set is displayed in all segments.

(9) Program link

- The program link function is provided to link program data with each other, and it is set every program data.
- Enter a program data No. of the link destination in this item.
- Initial value 0 shows that program data are not linked.
- If presently set program data No. is entered, an infinite loop is produced.
- If the link source end point SP does not coincide with the link destination start point SP, the SP changes stepwise in the link operation.

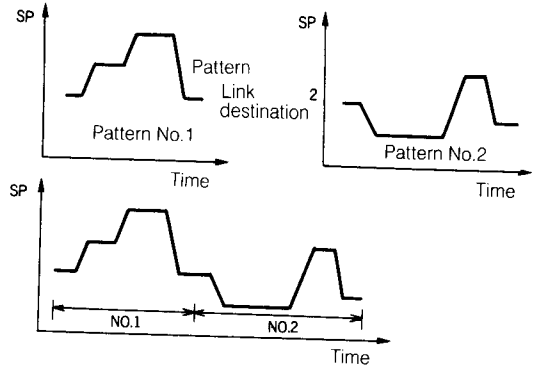

(10) PV shift

- The PV shift function is provided to set a PV correction value every segment by programming.
- The settable range is -100U to 100U.
- The value obtained by adding the PV bias and PV shift to a PV input value is regarded as a PV during operation.

Example: PV shift +5°C in segment ③ and PV shift +10°C in segment 5.

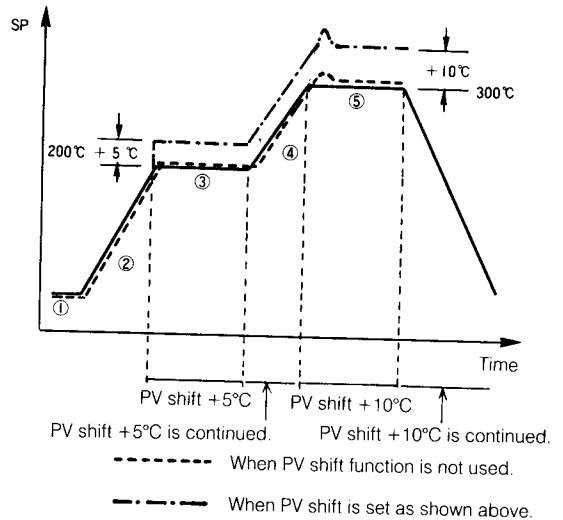

10. OPERATION MODE IN CONSTANT-VALUE CONTROL OPERATION

1. Constant value control operation mode

When item 1 of (selection or setting range) is entered in setup mode $\text{C}34$, the constant value operation mode is selected, and the constant value control is started by [RUN] key.

If the constant value control operation mode is selected, neither program pattern setting nor program operation can be done, while the setting and operation of SP, EV1, EV2, and one PID set can be done as a constant value controller. Set values are entered by [PID] key.

The PROG, SEG digital indicators and PROFILE indicator go out.
The following display appears.

Upper Display SP (SP, DEV, and OUT are selectable by [DISP] key in the upper display.)
DEV
OUT

Lower display PV

I. Outline of programming

1. Numeric change PID keys

Set points (SP), event values (EV1, EV2), whether auto tuning is done or not, PID values, output limits (OL, OH), manual reset (rE) and initial manipulated variables can be changed digitally by [PID] key.

Display/ setting order	Codes	Setup item	Selection or setting range	Initial value in display	Description
1	SP	SP	SP limit low-limit—high-limit	0 (U)	
2	E1	EV1	-1999 to 9999(U)	9999 (U)	Not displayed when parameter $\text{Et}1=4, 5, \text{ or } 6$
3	E2	EV2	-1999 to 9999(U)	9999 (U)	Not displayed when parameter $\text{Et}2=4, 5, \text{ or } 6$
4	At	Auto tuning selection	0: AT is not executed 1: System1 is executed by AT key. 2: System2 is executed by AT key.	0	Displayed only when AT is provided. Not displayed when setup $\text{C}12=1$. Set point value common to program control.
5	P	Proportional band	0.0 to 999.9% 0D, 6D type 0.1 to 999.9% 5G type	100.0	ON, OFF control is executed at 0.0. Not displayed when setup $\text{C}12=1$.
6	I	Integral time	0 to 3600 sec	0	No integral action is done when $I=0$. Not displayed when $P=0$ or setup $\text{C}12=1$.
7	d	Derivative time	0 to 1200 sec	0	No derivative action is done when $d=0$. Not displayed when $P=0$ or setup $\text{C}12=1$.
8	oL	Output low-limit	0.0 to high-limit% 0D, 6D type -10.0 to high-limit% 5G type	0.0 -10.0	Not displayed when $P=0$ or setup $\text{C}12=1$.
9	oH	Output high-limit	Low-limit to 100.0% 0D, 6D type Low-limit to 110.0% 5G type	100.0 110.0	Not displayed when $P=0$ or setup $\text{C}12=1$.
10	rE	Manual reset	0.0 to 100.0	50.0	Not displayed when $P=0, I \neq 0$ or setup $\text{C}12=1$.
11	out	Initial manipulated variables in PID action.	0.0 to 100.0	0.0	Not displayed when $P=0$ or setup $\text{C}12=1$. Set point values common to program control.

Be careful since At and out values remain effective after resetting the operation mode to the program control.

2. Numeric change PARA keys

Parameters are used for determining constants in constant value control.

Item characters are displayed in the upper display, while set point values are displayed in the lower display.

Setting of parameter mode is not necessary, if initial values satisfy the demanded specifications.

Display/ setting order	Codes	Setup item	Selection or setting range	Initial value in display	Description
1	<i>F I L T</i>	PV filter constant	0.0 to 120.0 sec	0.0	
2	<i>P b i R</i>	PV bias	-100 to 100(U)	0 (U)	Not displayed when PV=0% fixed is set in SETUP C25.
3	<i>c y</i>	Time proportional output cycle	5 to 120 sec (relay type) 1 to 60 sec (voltage type)	10	Displayed in 0D, or 6D (time proportional), and not displayed in 5G (current output) type.
4	<i>o u t L</i>	Manipulated variables change limit	0.0 to 100.0% (every 0.5 sec)	100.0	Not displayed when the main output of 5G (current output) is set (SP).
5	<i>d i f f</i>	ON/OFF control differential	0 to 100U	5 (U)	Displayed in 0D, or 6D (time proportional), and not displayed in 5G (current output) type.
6	<i>E t 1</i>	Event 1 type	0: PV (Direct action) 1: PV (Reverse action) 2: Deviation (Direct action) 3: Deviation reverse action 4: RUN 5: READY 6: END	0	Relay is set to NO in PV direct action, and set to NC in PV reverse action.
7	<i>H Y S 1</i>	Event 1 hysteresis	0 to 100U	5 (U)	This item specifies the differential gap in event on-off operation.
8	<i>E t 2</i>	Event 2 type	0: PV (Direct action) 1: PV reverse action 2: Deviation (Direct action) 3: Deviation reverse action 4: RUN 5: READY 6: END	0	
9	<i>H Y S 2</i>	Event 2 hysteresis	0 to 100U	5 (U)	

No display appears in case of program protect (*P r t c*) of parameter 1 (display/setting order), (SP bias) of 4, and (G.SOAK width) of 5 in the program controller.

The (END) of (selection or setting range) 6 of (event type) in 6 or 8 is not related to the constant value control. However, be careful since these setting operations are effective when the operation mode has been reset to the program controller.

3. Keys which are not effective for constant value control

The keys marked with x in the right figure are not effective for constant value control.

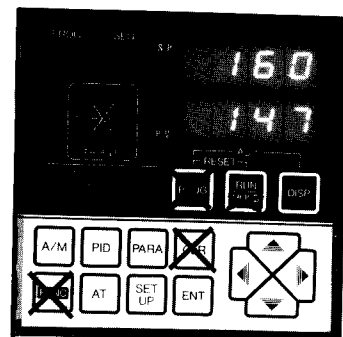

II. Outline of operation

The constant value operation mode is selected by inputting 1 in setup mode **C34**.

The program is set to the READY mode.

Confirm and set SP values, PID values, event values, etc. before starting the constant value control operation.

1 Starting a program

Press **RUN/HOLD** key. The constant value control operation is started simultaneously when this key is pressed.

2 Starting auto tuning

Press **AT** key.

- The auto tuning is executed when the following requirements are fully satisfied.
 - RUN mode
 - AUTO mode
 - PID constant "Rt" is set to 1 or 2.
 - PV is within the range.
- When auto tuning is normally executed and finished, the PID group constants are set to new constants by auto tuning at the end time.
- For stopping auto tuning, press **AT** key halfway.

The auto tuning is stopped, and PID constants are not rewritten.

Action

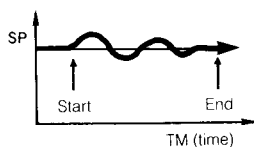

The on-off operation is repeated twice in the vicinity of a set temperature to operate and reset PID values. Whether auto tuning is turned on or off first depends upon PV and SP at that time.

3 Selecting manual control for the process

Display	Key operation	Description of contents
SP 200 PV 180	Press A/M key.	Main output (MV or SP) is indicated in the upper display, and PV is indicated in the lower display.
	Press ▲ key. (Numeric)	MV or SP change Enter a numeric (output value) by MULTI-keys. This value is effective, even if ENT key is not pressed.

When returns to auto operation, press **A/M** key again.

4 Stopping a program

Display	Key operation	Description of contents
SP 200 PV 180		Running
SP 200 PV 180	Press RUN/HOLD key while pressing PROG key.	Program is reset to the ready mode. • RUN and HLD LEDs go out.

11. MODEL SELECTION GUIDE AND SPECIFICATIONS

Model selection guide

I **II** **III** **IV** **V** **VI**

Example :

I **II** **III** **IV** **V** **VI**
DCP216 5G K09 A 007 00

Code No.	Model No.	Specifications					
I	Basic model number	DCP 216	Digital program controller				
		Output type Control mode	0D	Relay output SPDT (ON-OFF) Time proportional PID			
			5G	Current output 4 to 20mA DC Continuous proportional PID			
6D	Voltage output 22.5V DC + 10% (ON-OFF) Time proportional PID						
III	Type of input range		Type of input	Range	PV range code	Accuracy	Range change
		T44	Thermocouple T (CC)	-199.9 to 300.0°C -300 to 700°F	6	+0.2% FS	Possible
		J08	Thermocouple J (IC)	0 to 800°C 0 to 1600°F	2		
		E08	Thermocouple E (CRC)	0 to 800°C 0 to 1800°F	1		
		K04	Thermocouple K (CA)	0.0 to 400.0°C 0 to 750°F	12		
		K08	Thermocouple K (CA)	0 to 800°C 0 to 1600°F	11		
		K09	Thermocouple K (CA)	0 to 1200°C 0 to 2400°F	3		
		U13	Thermocouple N	0 to 1300°C 32 to 2372°F	9		
		Y13	Thermocouple PL II	0 to 1300°C 32 to 2372°F	10		
		R16	Thermocouple R (PR13)	0 to 1600°C 0 to 3100°F	4		
		S16	Thermocouple S (PR10)	0 to 1600°C 0 to 3100°F	5		
		B18	Thermocouple B (PR30-6)	0 to 1800°C 0 to 3300°F	0		
		D19	Thermocouple PR40-20	0 to 1900°C (0 to 3400°F)	8		
		W23	Thermocouple W (Wre5-26)	0 to 2300°C 0 to 4200°F	7		
		Z13	Thermocouple Ni=NiMo	0 to 1300°C 32 to 2372°F	16	+0.2% FS	Impossible
		F01	Pt100 (IEC, DIN and JIS)	0.0 to 100.0°C 0.0 to 200.0°F	34	+0.2% FS	Possible
		F03	Pt100 (IEC, DIN and JIS)	0.0 to 300.0°C 0.0 to 500.0°F	33		
		F05	Pt100 (IEC, DIN and JIS)	0.0 to 500.0°C 0 to 900°F	29		
		F32	Pt100 (IEC, DIN and JIS)	-100.0 to 150.0°C -150.0 to 300.0°F	32		
		F33	Pt100 (IEC, DIN and JIS)	-40.0 to 60.0°C -40.0 to 140.0°F	30		
		F36	Pt100 (IEC, DIN and JIS)	-50.0 to 200.0°C -50.0 to 400.0°F	31		
		F46	Pt100 (IEC, DIN and JIS)	-199.9 to 200.0°C -300.0 to 400.0°F	21		
		F50	Pt100 (IEC, DIN and JIS)	-200 to 500°C -300.0 to 900.0°F	20		
		P01	JPt100 (JIS Pt100)	0.0 to 100.0°C 0.0 to 200.0°F	28		
		P03	JPt100 (JIS Pt100)	0.0 to 300.0°C 0.0 to 500.0°F	27		
		P05	JPt100 (JIS Pt100)	0.0 to 500.0°C 0 to 900.0°F	23		
		P32	JPt100 (JIS Pt100)	-100.0 to 150.0°C -150.0 to 300.0°F	26		
		P33	JPt100 (JIS Pt100)	-40.0 to 60.0°C -40.0 to 140.0°F	24		
		P36	JPt100 (JIS Pt100)	-50.0 to 200.0°C -50.0 to 400.0°F	25		
		P46	JPt100 (JIS Pt100)	-199.9 to 200.0°C -300.0 to 400.0°F	22		
		C01	Current 4 to 20mA DC linear	Programmable -1999 to 9999	40	+0.2% FS	Possible
		M01	Voltage 0 to 10mV DC linear	Programmable -1999 to 9999	41		
		V01	Voltage 1 to 5V DC linear	Programmable -1999 to 9999	45		
L02	Voltage -10 to 10mV DC linear	Programmable -1999 to 9999	42				
IV	Power	A	90 to 264V AC 50-60Hz				
V	Optional function (1)		Auxiliary output (4 to 20mA DC)	Auto tuning	RS-422 Communication	RS-232C Communication	
		000	—	—	—	—	
		001	○	—	—	—	
		002	—	○	—	—	
		003	○	○	—	—	
		004	—	○	○	—	
		005	—	○	—	○	
		006	○	○	○	—	
007	○	○	—	○			
VI	Optional function (2)	00	Data are not attached				
		D0	Data are attached				
		T0	Tropical treatment				
		B0	Data are attached plus tropical treatment				

(Note) Mark ○ shows that the corresponding function is provided.

SPECIFICATIONS

Program storage capacity	No. of programs	19 programs			
	No. of segments per program	20 segments			
	No. of segments for all programs	380 segments			
	No. of events for all programs	200 events in total in program No. 1 to 7 200 events in total in program No. 8 to 14 200 events in total in program No. 15 to 19 (Total number of PV, deviation, RUN, READY END, time event, and PV shift)			
Indication and setting	Indication and setting ranges	See the model selection guide.			
	Indication accuracy	$\pm 0.2\%$ FS $\pm 1U$ $\pm 5.0\%$ FS at 260°C max. in case of T/C B type. (U: Industrial unit)			
	Indication and setting resolution	See the model selection guide			
	Time units	0 to 99 hours 59 min, or 0 to 99 min 59 sec			
Input	Input sampling cycle	500 msec			
	Type of input	Thermocouple	RTD (100 ohm pt)	Current	Voltage
	Impedance	1M Ω min.	—	100 Ω	1M Ω min.
	Allowable wiring resistance	250 Ω max.	4 Ω max.	—	—
	Input circuit failure indication	Upscale (Regarded as 110%)	Upscale (When the element was broken)	Downscale (Regarded as -10%)	—
	Digital filter	System: First-order lag filter Time constant: 0.0 to 120.0 sec variable (0.0: filter off.)			
	PV bias	-100 to 100U variable			
Control	Control system	PID control system, deviation value derivative type			
	Proportional band (P)	0.1 to 999.9% FS, Resolution 0.1%, (ON-OFF control at P=0)			
	Integral time (Reset time) (I)	0 to 3600 sec, Resolution 1 sec, (PD control at I=0)			
	Derivative time (Rate time) (D)	0 to 1200 sec, Resolution 1 sec, (PI control at D=0)			
	Direct/reverse action	Selectable by set-up			
	Output type	Relay output	Voltage output	Current output	
	Control mode	Time proportional PID PD+MR or ON-OFF	Time proportional PID PD+MR or ON-OFF	Current proportional PID or PD+MR	
	Output ratings	SPDT 250 V ac 5 A resistive load	22.5 V dc $\pm 10\%$ Lower than 75 mA	4 to 20 mA dc (2.4 to 21.6 mA dc)	
	Cycle time	5 to 120 sec	1 to 60 sec	—	
	Allowable load resistance	—	—	600 Ω max.	
	Scaling	—	—	For SP output, -1999 to 9999, settable	
	Remote operation Switch ass'y (Contact input)	No. of inputs	8 contacts Dry contact input		
Program selection		5 contacts Program number selection (2 ⁰ , 2 ¹ , 2 ² , 2 ³ , 10) No. 1 to 19 program selection			
Program operation		3 contacts (Operation start ... 1, Hold ... 1, Reset ... 1)			
Event output	Setting type	PV, deviation, RUN, READY, END, time			
	Setting range	PV: 0 to 100% FS Deviation: -50 to +50% FS Time: 0 to 99.59 (in time unit)			
	Differential gap	0 to 100U			
	Output	PV, deviation, RUN, READY : Relay contact (reversible) SPST \times 2 Time : Transistor open collector ... 4 outputs (Power supply: 24 V dc, 100 mA dc max user-supplied)			
	Relay contact ratings	250 V ac, 5 A resistive load (PV, deviation)			

Communication function RS-422 (Optional function)	Communication system	Network	Multidrop system 1-to-16 units max. (Instrument serves as a slave station only)
		Information direction	Half-duplex
		Synchronous system	Start-stop synchronization
	Interface system	Transmission type	Balancing (differential) type
		Data line	Bit serial
		Signal line	3 transmitting/receiving lines
		Transmission speed	1200, 2400, 4800, 9600 bps
		Communication distance	300 m max.
	Message character	Others	Conforms to RS-422
		Character configuration	11 bits/character
Format		1 start, 2 stop bits (standard)	
Communication function RS-232C (Optional function)	Communication system	Data code	8-bit binary code
		Network	1-to-1 (Slave station function only)
		Information direction	Half-duplex
	Interface system	Synchronous system	Start-stop synchronization
		Transmission type	Unbalanced type
		Data line	Bit serial
		Signal line	3 transmitting/receiving lines
		Transmission speed	1200, 2400, 4800, 9600 bps
	Message character	Communication distance	15 m max.
		Others	Conforms to RS-232C
Character configuration		11 bits/character	
Common specifications	Format	1 start, 2 stop bits (standard)	
	Data code	8 bit, ASCII code	
	Rated supply voltage/Frequency	100 to 240 V ac • 50/60 ± 2 Hz	
	Supply voltage/Frequency	90 to 264 V ac • 50/60 ± 4 Hz	
	Power consumption	Max. 17.5 VA	
	Insulation resistance	Higher than 50MΩ, 500 V dc megger (between power terminal and case)	
	Dielectric strength	1500 V ac for 1 min, or 1800 V ac for 1 sec (between power terminal and case)	
	Mass	Approx. 1.0 kg	
	Allowable ambient temperature	0 to 50°C	
	Allowable ambient humidity	10 to 90%RH (No dew condensation is allowable)	
	Vibration resistance	4.9m/s ² max. (10 to 60 Hz XYZ directions 2 hours each)	
	Shock resistance	490m/s ² max. (3 times each in vertical direction, in packed state)	
	Memory backup	Lithium battery (for longer than 5 years)	
	Environmental condition	Permanently connected equipment, indoor use, Panel mounted equipment	
	Conformed standard	EN61010-1, EN50081-2, EN50082-2	
Installation category (Over voltage category)	Category II (IEC664-1, EN61010-1)		
Pollution degree	Pollution degree 2		

12. EXTERNAL DIMENSIONS

External dimensions

[in mm]

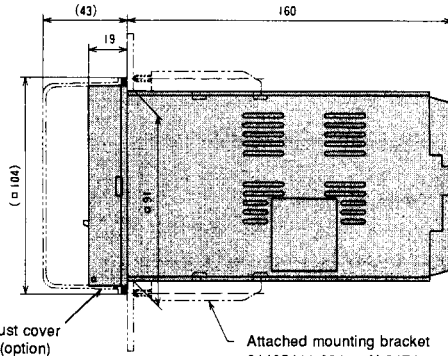
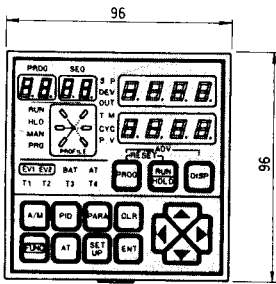

Packing, dust cover
8140330A (option)

Attached mounting bracket
81405411-001 or N-3174.

Panel cutout size

[in mm]

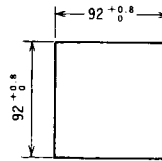
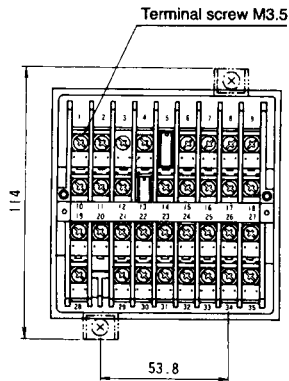

Panel cutout size

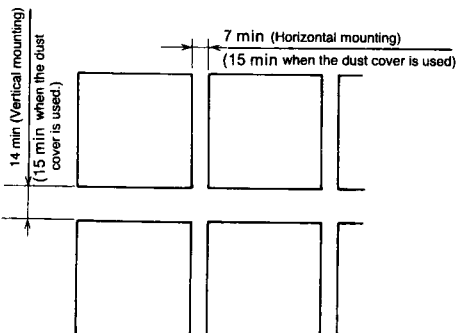

Vertical and horizontal mounting panel cutout sizes (recommendable)

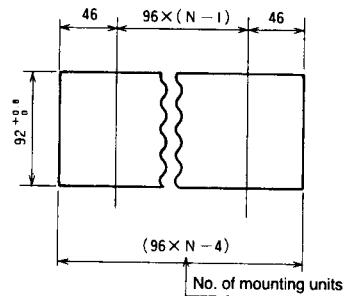

Panel cutout size for closed mounting (recommendable)

13.

INSTALLATION

1. Mounting place

Mount the instrument at following places in the same way as in general digital electronic instruments.

- (1) A place free of any noticeable temperature change at normal temperature or so (within 0° to 50°C)
- (2) A place free of a corrosive gas atmosphere
- (3) A place not subjected to a low or high humidity (10 to 90% RH)
- (4) A place free of mechanical vibrations (less than 0.2G, 10 to 60 Hz)
- (5) A place free of dust particles, soot, or the like
- (6) A place where is not affected by electrical noises
- (7) A place where is not subjected to a strong magnetic field
- (8) A place free of any flammable liquids or vapors.

2. Mounting method

- (1) Keep instrument within a mounting angle of 15°, if it is tilted down from the horizontal level on the rear side.
- (2) Use a steel panel having a plate thickness of thicker than 2 mm.
- (3) Insert the instrument case from the panel cutout.
- (4) Fix the upper and lower panels of the instrument securely by using the attached mounting brackets.
- (5) Fix the panels to lower mounting bracket (1) first.
- (6) When the mounting brackets are flush against both a and b (where there is no longer any play between the mounting brackets and mounting panel), tighten the screw by about one turn. Do not tighten the screws too hard. Doing so might deform the case.

The controller must be mounted on a mounting panel, and its terminals covered to prevent electrical shock.

An optional terminal cover (Part No.: 81446084-002) is so separately.

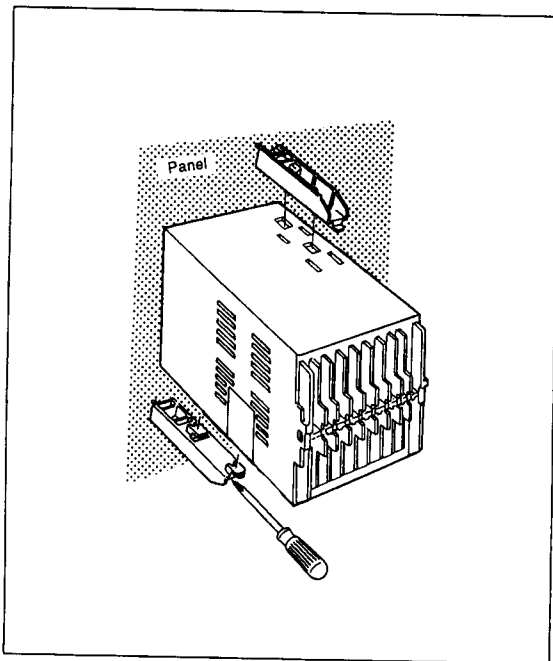

Fig. 13-1 Mounting method

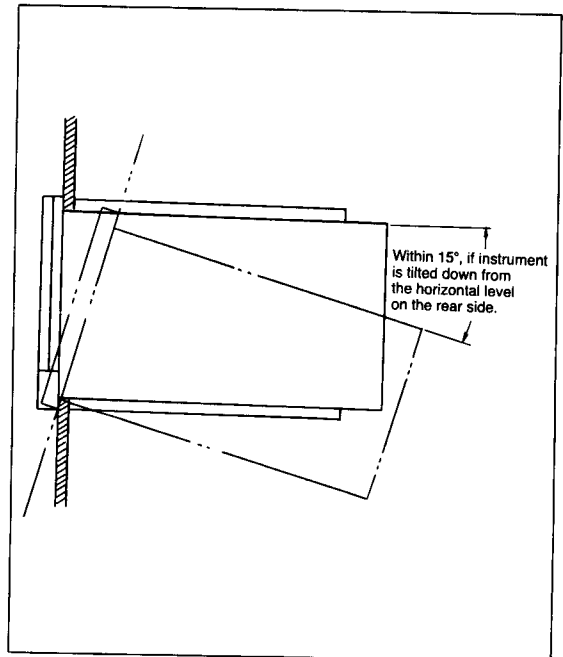

Fig. 13-2 Mounting angle

Caution: Use shielded cables for the DCP200 input/output cables so as not to introduce noises.

1. Cautions on wiring

- (1) Digital units are apt to be affected by electrical noises, so that a trouble and a wrong operation may be caused by those which are negligible for analog units. In order to prevent an effect of noises, connect cables with due care according to the instructions of this chapter.
- (2) Use solderless terminals conforming to M3.5 screws.
- (3) Connect cables according to the wiring diagram of the corresponding model number after confirming the instrument model number. After wiring, check them for normal conditions.
- (4) Separate input/output signal cables from a power cable as far as possible.
Don't pass both cables through the same conduit or duct.

2. Input/output signal cables

2.1 Thermocouple input signal cable

- (1) Connect a thermocouple line cable to terminals in case of a thermocouple input. Connect the thermocouple input by extending it with a compensating lead wire, if the wiring distance is long or a sensor is connected to terminals.
Use a shielded compensating lead wire.

2.2 Input signal cables for those other than thermocouples, and digital input/output signal cables

- (1) Use a shielded polyethylene insulated vinyl sheathed cable for instrumentation use conforming to JCS-364 or equivalent (generally called a twisted shielded for instrumentation use).
- (2) A shielded multiconductor microphone cord (MVVS) may be used, if electromagnetic induction noises are comparatively low.

References Recommendable commercially available twisted shielded cables (JAPAN)

Fujikura Cable Co.	2 con- ductors	IPEV-S-0.9 mm ² ×1 P
	3 con- ductors	ITEV-S-0.9 mm ² ×1 T
Hitachi Cable Co.	2 con- ductors	KPEV-S-0.9 mm ² ×1 P
	3 con- ductors	KTEV-S-0.9 mm ² ×1 T

2.3 Remote switch input contact

- (1) Use a no-voltage remote switch input and a micro-current contact.
- (2) Hold a contact signal for longer than one second.

2.4 Signal cables for communication use (additional function)

- (1) Be careful since the communication circuit may be broken, if (+) and (-) communication terminals are shorted with each other.
- (2) Don't connect the DCP200 together with another instrument connected to the same RS-422 communication line to the same addresses.
(Zero has no communication)

3. Grounding

- (1) Connect the instrument by one-point grounding to G terminal. Don't perform any jumper wiring.
Mount a grounding terminal board (earth bar) separately and connect shielded cables, etc. to ground as shown in Fig. 11-1, since only one G terminal is provided.
 - Grounding type: Category 3 grounding or higher (Lower than 100Ω)
 - Grounding wire: Annealed copper wire of more than 2mm² (AWG14)
 - Grounding wire length: Max. 20 m

4. Instrument power supply

- (1) Obtain the DCP200 power supply from a single-phase instrument power source in such a way as the instrument is not affected by noises as much as possible.

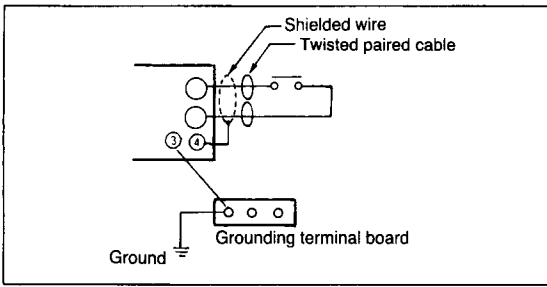

Fig. 11-1 Grounding method

(2) It is recommended to use a line filter having an additional insulation transformer, if noises are introduced noticeably from the power source.

- Line filter
Part number 81446364-001

Be careful not to bundle the primary and secondary of the power cable together or not to put them into the same conduit or duct after taking a countermeasure against noises.

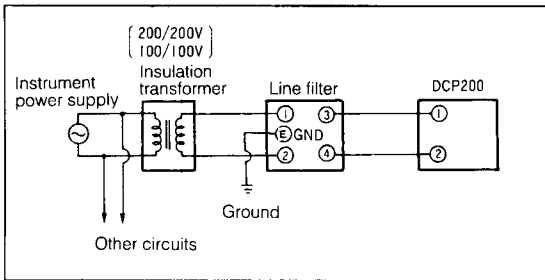

Fig. 11-2 Power noise reduction method

5. Noise generation sources and noise reduction methods

5.1 Noise generation sources

(1) The following noise generation sources are generally presumable.

- ① Relays and contacts
- ② Solenoid coils and solenoid valves
- ③ Power line (higher than 100 V ac, in particular)
- ④ Inductive load
- ⑤ Motor commutator
- ⑥ Phase angle control SCR
- ⑦ Radio communication equipment
- ⑧ Welding machine

5.2 Noise reduction method

(1) A CR filter is effective for quick-rising noises.

- Recommendable CR filter
Part number 81446365-001
(953M50033311 manufactured by Matsuo electric or equivalent)

(2) A varistor is effective for noises having a high crest value. Be careful since the varistor is shorted, if it becomes defective.

- Recommendable varistor
Part number 81446366-001 for 100 V use
81446367-001 for 200 V use.

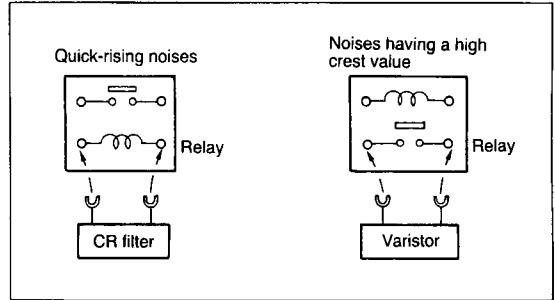
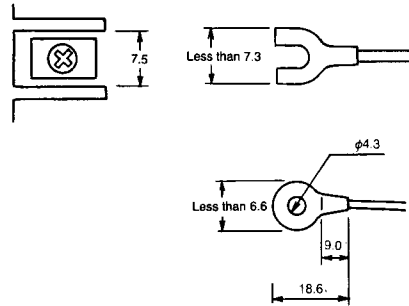





Fig. 11-3 Noise reduction method

For terminal connection, use solderless terminals conforming to M3.5 screws.



(Note) Use circular solderless terminals so that cables are not disconnected from terminals, if the instrument is mounted at a place subjected to noticeable vibrations and impacts.

The following table shows the meanings of symbols in the terminal wiring label on the instrument top.

Symbol	Description
	Alternating current
	Earth (ground) terminal
	Caution, risk of electric shock
	Caution (refer to accompanying documents)

16.

MAINTENANCE

Cleaning: Clean the instrument with a soft, dry cloth when it becomes dirty.

Replacing Parts: Only authorized personnel are allowed to replace parts.

Replacing Fuses: When replacing fuses provided on the power supply circuit, use only standard parts specified bellow.

Standard	IEC 127
Type	Time-lag (T)
Voltage rating	250 V
Current rating	2 A

APPENDIXES

- (1) Program pattern preparation example**
- (2) Setup setting example**
- (3) Parameter setting example**
- (4) Programming example**
- (5) Program work sheet**

(1) Program preparation example

Program No.:

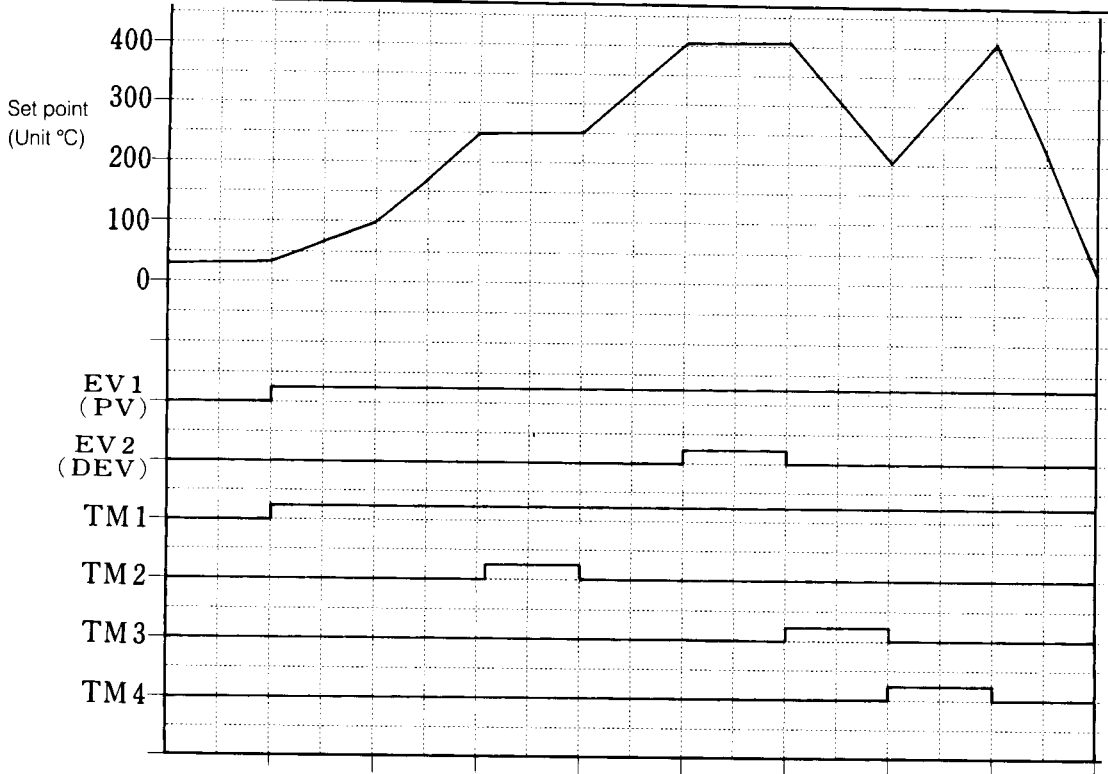

Programming map

Map position	Segment item		1	2	3	4	5	6	7	8	9
A	SP time	Upper-display: S P	30	100	250	250	400	400	200	400	30
		Lower-display: Time	2.00	4.00	3.00	7.00	4.00	7.00	4.00	4.00	4.00
B	Event No.1	Upper-display: —									
		Lower-display: Set point (PV)		100							
C	Event No.2	Upper-display: —									
		Lower-display: Set point (DEV)					5	600			
D	Time event No.1	Upper-display: ON		0.00							
		Lower-display: OFF		37.00							
E	Time event No.2	Upper-display: ON			1.00						
		Lower-display: OFF			7.00						
F	Time event No.3	Upper-display: ON						0.00			
		Lower-display: OFF						7.00			
G	Time event No.4	Upper-display: ON								0.00	
		Lower-display: OFF								4.00	
H	PID group selection	Upper-display: P I d									
		Lower-display: Group No.	1	1	1	1	2	2	2	3	3
I	G.SOAK setting	Upper-display: 9.5									
		Lower-display: no or YES	no	no	no	YES	no	no	no	no	no
J	PV start setting	Upper-display: P S t A									
		Lower-display: no or YES	YES	YES	YES	YES	YES	YES	YES	YES	YES
K	Cycle setting	Upper-display: C Y C L									
		Lower-display: Cycle No.	0	0	0	0	0	0	0	0	0
L	Progrm link setting	Upper-display: P L I n									
		Lower-display: Enter link progrm data No.	0	0	0	0	0	0	0	0	0
M	PV shift value	Upper-display: S H F t									
		Lower-display: Shift value									

(Note) Set the max value of segment 7 DEV so as not to allow EV2 to function between segments 7 to 9. -50% FS to +50% FS

(2) Setup setting example

SET UP Setup setting procedure

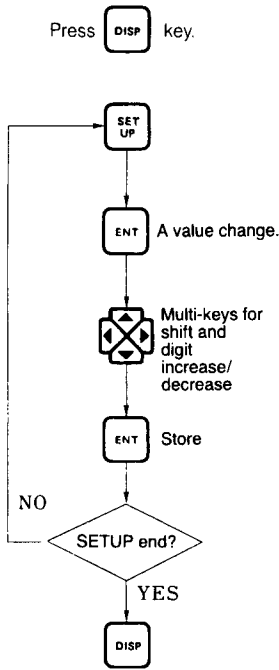

Step	Key operation	Display	Description of display	Remarks
1	Press SET UP key.		Proceed to the next step, since the initial value is the preset value before delivery from factory.	See pages 12 and 13.
16	Press SET UP key.		Program time unit is minute and second. (: Minue and second)	
17	Press ENT key.		flashes.	
18	Press this key.		Digit 1 is displayed.	
19	Press DISP key.		1 is set.	
20	Press ENT key.	SP TM 	SETUP has finished.	C30 to C34 are not related to setup.

(3) Parameter setting example

PARAM Parameter setting procedure

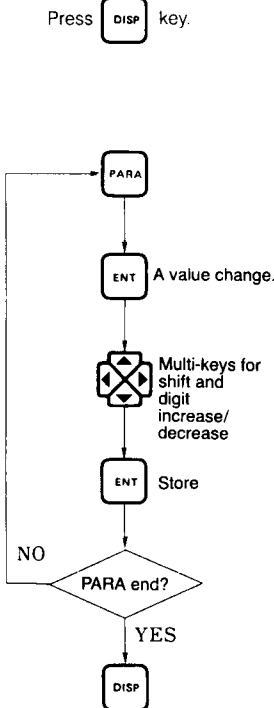

Step	Key operation	Display	Description of displays	Remarks
1	Press PARAM key.		Proceed t the next step, since the initial value is the preset value before delivery from factory.	See pages 19 and 20.
9	Press PARAM key.		Change initial value 0 for setting DEV of event No.2.	
10	Press ENT key.		The last digit flashes.	
11	Press this key.		Change the digit to 2 .	Initial value 2 : Deviation
12	Press ENT key.		The higher side of the (+) DEV set point is on.	
13	Press PARAM key.		Set the DEV event on-off range to 5°C in event No.2. There is no change because the initial value is 5 .	
14	Press DISP key.	SP TM 	Parameters setting has finished.	

(4) Programming example

Programming setting procedure

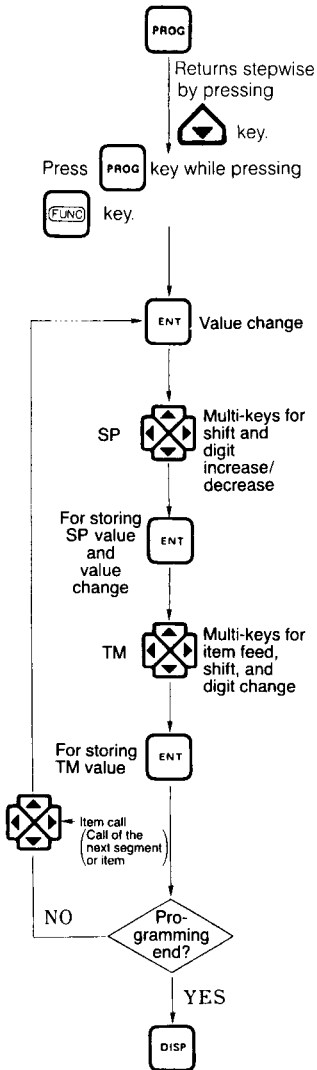









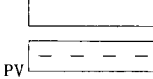

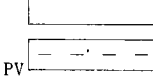

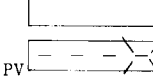



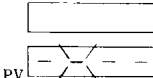

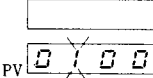

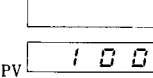

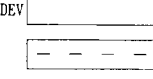

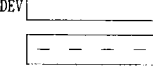

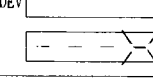



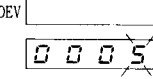





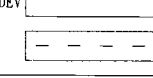

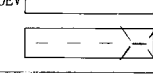
Step	Key operation	Display	Description of displays	Display of profile
1	Press key. (Returns stepwise by pressing key.)		A program No. is assigned. SP, TM LEDs light.	
2	Press key while pressing key.	SP TM	Programming mode is set. PRG LED lights. decimal point lights.	
3	Press key.	SP TM	Segment 1 The last digit of SP flashes. SP value setting (Temperature is set to °C.)	
4	Press this key first, and then, press this key.	SP TM	After pressing shift (left) key, change the flashing digit by a digit increase key. Set SP=30 (°C).	
5	Press key.	SP TM	The last digit of TM flashes. TM value setting. (Time unit is set to minute/second.)	
6	Press this key first, and then, press this key.	SP TM	Press shift (left) key, and then, change the flashing digit by a digit increase key. Set TM=2.00 (min.)	
7	Press key.	SP TM	SP=30°C and TM=2 min have been stored.	
8	Press this key.	SP TM	Segment 2 	-
9	Press key.	SP TM	SP value setting	-
10	Repeat step 4.	SP TM	SP=100(°C) is set.	
11	Press key.	SP TM	TM value setting	
12	Repeat step 6.	SP TM	TM=4.00 (min) is set.	
13	Press key.	SP TM	SP=100°C and TM=4 min have been stored.	
~~~~~				
	Press  key.	SP TM	<b>Segment 9</b> SP=30°C and TM=4 min have been stored.	

**PV event**

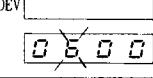
**DEV event**

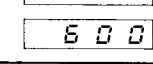
(Note)  
A wrong event can be erased, if it has been set by mistake.  
 flickers  
The display returns to "-----" after erasing the event.

Step	Key operation	Display	Description of displays	Display of profile
1	 Press this key.		PRG LED lights continuously. PV EV1 LED lights.	
2	 Press this key.		Press an item feed (right) key continuously until ^{SEG} 2 appears.	
3	Press  key.		The last digit of PV value flashes. 	
4	 Press this key twice.		Shift	
5	 Press this key.		100 is displayed.	
6	Press  key.		PV event 100°C is set.	
7	 Press this key.		DEV EV2 LED lights when ^{SEG} 2 appears.	
8	 Press this key (four times)		Stop pressing the key when ^{SEG} 5 appears.	
9	Press  key.		The last digit  flashes.	
10	 Press this key.		5 is displayed.	
11	Press  key.		DEV event 5°C is set.	
12	 Press this key.		^{SEG} 7 is displayed.	
13	Press  key.		The last digit  flashes.	
14	 Press this key first, and then, press this key.		600 is displayed.	
15	Press  key.		DEV event 600°C is set.	

	Step	Key operation	Display	Description of display	Display of profile
Time event	16	Press this key.		T1 LED lights in ^{SEG} 7.	
	17	Press this key. (four times)		Stop pressing the key when ^{SEG} 2 appears.	
	18	Press  key.		The last digit  flashes.	
	19	Press this key first, and then, press this key.		0.00 is displayed.	
	20	Press  key.		T1 time event ON is set to 0 min.	
	21	Press this key first, and then, press this key.		37.00 is displayed.	
	22	Press  key.		T1 time event OFF is set to 37 min.	
	23	Repeat 16 to 21 steps. Press  key.		^{SEG} 4. T2 LED ON is set to 1 min. OFF is set to 7 min.	
	24	Repeat 16 to 21 steps. Press  key.		^{SEG} 5. T3 LED ON is set to 0 min. OFF is set to 7 min.	
	25	Repeat 16 to 21 steps. Press  key.		^{SEG} 8. T4 LED ON is set to 0 min. OFF is set to 4 min.	
PID	26	Press this key.		^{SEG} 8. P I d is displayed in 8. Since segments 1 to 4 apply to 1 group, go to segment 5.	
	27	Press this key.		^{SEG} 5. 5 is displayed.	
	28	Press  key.		PID 1 flashes.	
	29	Press this key.		No.2 PID group is set to segment 5.	
	30	Repeat 27 to 30 steps. Press  key.		No.2 PID group is applied to segment 5 to 6. No.3 PID group is applied to segments 7 to 9.	

	Step	Key operation	Display	Description of display	Display of profile
Guaranteed soak	31	Press this key.	9.5. no	9.5 (guaranteed soak) and ^{SEG} no are displayed in  9.	
	32	Press this key. (four times)	9.5. no	Display ^{SEG} 4.	
	33	Press  key.	9.5. <del>no</del>		
	34	Press this key.	9.5. <del>YES</del>		
	35	Press  key.	9.5. YES	Guaranteed soak is set in segment 4.	
PV event	36	Press this key.	P.S.E.A. no	PV start YES or NO may be set in an optional segment.	
	37	Press  key.	P.S.E.A. <del>no</del>		
	38	Press this key.	P.S.E.A. <del>YES</del>		
	39	Press  key.	P.S.E.A. YES	YES is set for PV start.	
Cycle	40	Press this key.	CYCL 0	Since no cycle is required, 0 is set.	
Program link	41	Press this key.	P.LI n 0	Set 0, since no program link is necessary.	
PV shift	42	Press this key.	S.H.F.E. ----	PV shift is displayed. If <b>S.H.F.E.</b> is not displayed, refer to item 20 on page	
	43	Press  key.	S.H.F.E. <del>----</del>		
	44	Press this key. (four times)	S.H.F.E. ----4	Display ^{SEG} 4.	
	45	Press  key.	S.H.F.E. 3	Set PV shift 3°C.	
	46	Press  key.	  	Programming ends now. Press  key after confirming the program by using  key.	

## ☆ COMMENTS ON ABBREVIATIONS

Advance	: A program data can be advanced to the next segment from the present segment by pressing (ADV) key.	Hold	: (Holding) Opposite to the operation A program is stopped advancing temporarily when the control mode is in progress.
Auto tuning	: Optimum PID values are automatically calculated and set.	HYS	: (Hysteresis) A differential gap of event on-off operation A differential gap
Auxiliary output	: Two kinds of auxiliary outputs are provided; PV and SP.	MAN	: (Manipulated operation) An output value is sent over a range of 0 to 100% in manual operation mode.
Auto/Manual	: Auto/manual operation	MV	: (Manipulated variable) A signal to be sent to a final controlling element Example: 4 to 20 mA
Clearance	: Set data are cleared to zero.	OL	: (Low-limit output value) An output (manipulated variable low-limit Set the minimum limit value of outputs
Cycle	: The same program data is repeated several times. Since it is repeated twice when CYCL=2, the operation is done three times in total.	OH	: (High-limit output value) An output (manipulated variable high-limit value Set the maximum-limit value of outputs
Deviation	: A value obtained by subtracting a set point value (SP) from a process variable (PV).	OUT	: (output 1) The output is displayed as -10 to 110.0% when the output range is from 4 to 20 mA, for example.
Display	: The contents to be indicated on the right 4-digit indicator are selected by pressing DISP key.	PARA	: (Parameters) Set parameters to desired values.
Event signal	: An on-off signal to be output according to the control conditions alarm event, control event, time event, etc.	PID	: (Three-mode positioning) P: Proportional action I: Integral action or reset action D: Derivative action or rate action
EV1	: Event 1 signal 1 Same as described in EV.	PROG	: (Programming) Program data setting Set program values to various values on the time axis.
EV2	: Event 2 signal 2 Same as described in EV.	PROTECT	: (Protection) Inhibition of resetting program data
FUNC	: FUNC key does not function by itself. The instrument is set to the programming mode when this FUNC key is pressed together with PROG key. A program can be erased by pressing FUNC key together with CLR key in the READY mode.		
G.SOAK	: (Guarantee soak) A program is not advanced until the absolute value of a deviation between a PV value and an SP value becomes within a set value of the G.soak width.		

PV	: (Process variables) Thermocouple input values, resistance thermometer bulb input variables, linear input, and other measured values.	T1	: Time event 1 An on-off signal 1 on the time axis
		T2	: Time event 2 An on-off signal 2 on the time axis
READY	: The instrument is ready for operation (=RDY)	T3	: Time event 3 An on-off signal 3 on the time axis
RUN	: (Running) A control operation mode Opposite to holding	T4	: Time event 4 An on-off signal 4 on the time axis
SEG	: (Segment) A partition or a segment of program data	TM	: (Time) Hour, minute, or minute, second display The display contents show the residual segment time or elapsed operation time.
SET UP	: Direct or reverse control action, input range, and other basic setting		
SP	: (Set point) A set point for controlling temperature, etc. for example		

*Specification are subject to change without notice.*

**YAMATAKE**

---

**Yamatake Corporation**

Control Products Division

1-12-2, Kawana

Fujisawa, Kanagawa, 251-8522, Japan

Phone: 81-466-20-2187

Fax: 81-466-20-2309

*This has been printed on recycled paper.*

Printed in Japan.

1st Edition: Issued in Feb., 1991

3rd Edition: Issued in Nov., 1998(W)