

DigitroniK Digital Control Programmers DCP 211/216

FEATURES

DigitroniK DCP 211/216 are proven, compact (96 mm x 96 mm) digital controllers for the control of temperature, humidity, pressure, flow, and other process variables.

- **Multiranges**
Sensors can be replaced without readjusting groups of thermocouples, resistance temperature detectors (RTDs), and linear inputs (current, voltage).
- **SP limit**
The reliable, robust DCP 211/216 can limit a data setting ranges and prevent process upsets due to input errors.
- **Clear LED displays**
The DCP 211/216's profile display uses LED segments to show process conditions (rising, soaking, falling), and the next segment conditions during program run. Two 4-digit, 7-segment numeric displays are easy to read.
- **Autotuning**
This option is an advanced function for both models that automatically calculates PID constants at startup time, and eliminates troublesome tuning.
- **Pattern link function**
The DCP 216 can execute complicated programming and partial cycling.
- **Constant value control**
One DCP 216 can operate as a program controller and a constant value controller.
- **Variable power supply**
Since the DCP 211/216 can use 90 to 264 Vac, they can be operated on 100, 110, 120, 200, 220, and 240 Vac power supplies without special wiring.

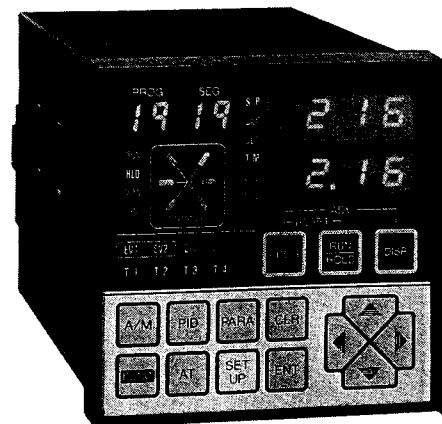

BASIC FUNCTION BLOCK DIAGRAM

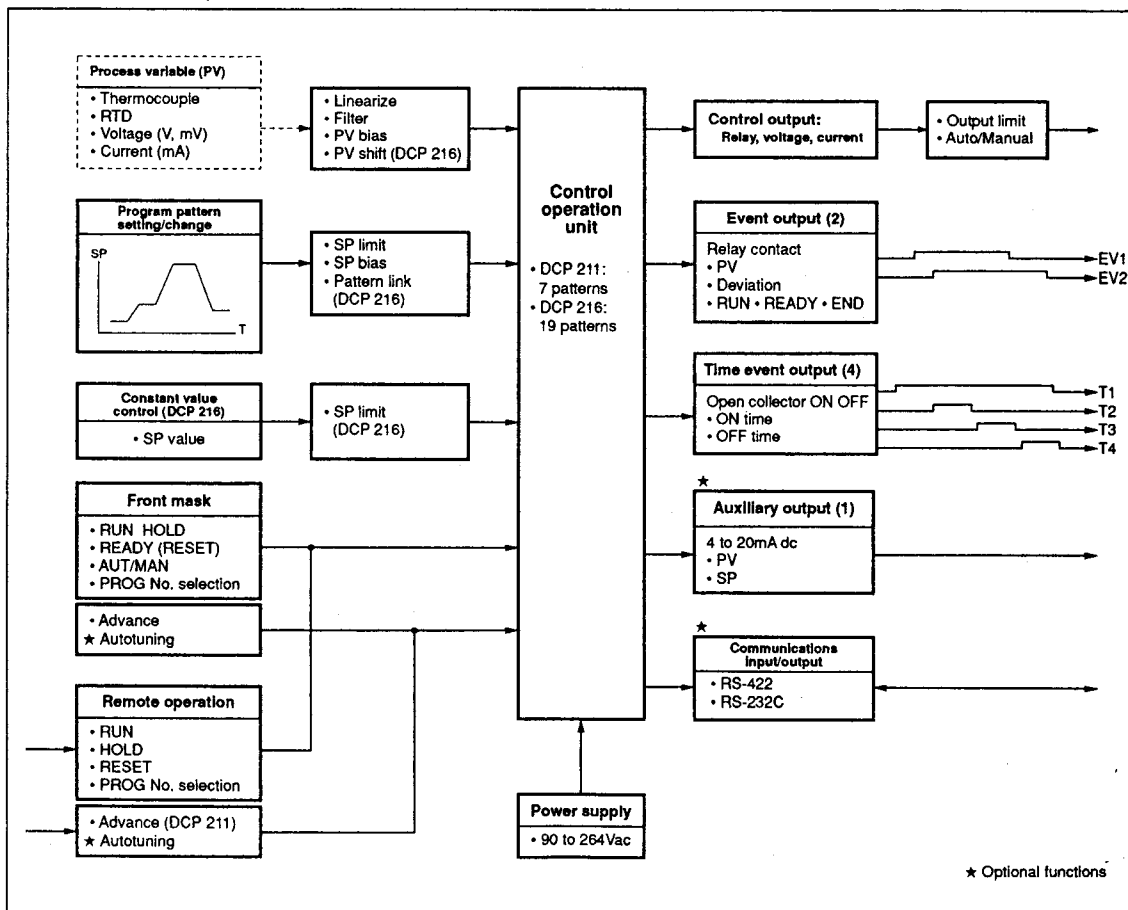

MODEL SELECTION GUIDE

I II III IV V VI

Examples: I II III IV V VI
DCP211 5G K09 A 007 01

Code No.	Model No.	Description							
I	Basic model No.	DCP211	Digital control programmer (7 patterns)						
		DCP216	Digital control programmer (19 patterns)						
II	Output type Control mode	0D	Relay output SPDT (ON-OFF) Time proportional PID						
		5G	Current output 4 to 20mA dc Continuous proportional PID						
		6D	Voltage output 22.5V dc ±10% (ON-OFF) Time proportional PID						
III	Type of input/range		Type of input	Range		Resolution		Accuracy	Range change
		T44	Thermocouple T (CC)	-199.9 to +300.0°C	-300 to +700°F	0.1°C	1°F	±0.2% FS	Possible
		J08	Thermocouple J (IC)	0 to 800°C	0 to 1600°F	1°C	1°F		
		E08	Thermocouple E (CRC)	0 to 800°C	0 to 1800°F	1°C	1°F		
		K04	Thermocouple K (CA)	0.0 to 400.0°C	0 to 750°F	0.1°C	1°F		
		K08	Thermocouple K (CA)	0 to 800°C	0 to 1600°F	1°C	1°F		
		K09	Thermocouple K (CA)	0 to 1200°C	0 to 2400°F	1°C	1°F		
		U13	Thermocouple N	0 to 1300°C	32 to 2372°F	1°C	1°F		
		Y13	Thermocouple PL II	0 to 1300°C	32 to 2372°F	1°C	1°F		
		R16	Thermocouple R (PR13)	0 to 1600°C	0 to 3100°F	1°C	1°F		
		S16	Thermocouple S (PR10)	0 to 1600°C	0 to 3100°F	1°C	1°F		
		B18	Thermocouple B (PR30-6)	0 to 1800°C	0 to 3300°F	1°C	1°F		
		D19	Thermocouple PR40-20	0 to 1900°C	0 to 3400°F	1°C	1°F	±0.3% FS	Possible
		W23	Thermocouple W (Wre5-26)	0 to 2300°C	0 to 4200°F	1°C	1°F	±0.2% FS	
		F01	JIS '89 Pt100 (equivalent to IEC and DIN)	0.0 to 100.0°C	0.0 to 200.0°F	0.1°C	0.1°F	±0.2% FS	
		F03	JIS '89 Pt100 (equivalent to IEC and DIN)	0.0 to 300.0°C	0.0 to 500.0°F	0.1°C	0.1°F		
		F05	JIS '89 Pt100 (equivalent to IEC and DIN)	0.0 to 500.0°C	0 to 900°F	0.1°C	1°F		
		F32	JIS '89 Pt100 (equivalent to IEC and DIN)	-100.0 to +150.0°C	-150.0 to +300.0°F	0.1°C	0.1°F		
		F33	JIS '89 Pt100 (equivalent to IEC and DIN)	-40.0 to +60.0°C	-40.0 to +140.0°F	0.1°C	0.1°F		
		F36	JIS '89 Pt100 (equivalent to IEC and DIN)	-50.0 to +200.0°C	-50.0 to +400.0°F	0.1°C	0.1°F		
		F46	JIS '89 Pt100 (equivalent to IEC and DIN)	-199.9 to +200.0°C	-300.0 to +400.0°F	0.1°C	1°F		
		F50	JIS '89 Pt100 (equivalent to IEC and DIN)	-200 to +500°C	-300.0 to +900.0°F	1°C	1°F		
		P01	JIS '89 JPt100 (JIS Pt100)	0.0 to 100.0°C	0.0 to 200.0°F	0.1°C	0.1°F		
		P03	JIS '89 JPt100 (JIS Pt100)	0.0 to 200.0°C	0.0 to 500.0°F	0.1°C	0.1°F		
		P05	JIS '89 JPt100 (JIS Pt100)	0.0 to 500.0°C	0 to 900.0°F	0.1°C	1°F		
		P32	JIS '89 JPt100 (JIS Pt100)	-100.0 to +150.0°C	-150.0 to +300.0°F	0.1°C	0.1°F		
		P33	JIS '89 JPt100 (JIS Pt100)	-40.0 to +60.0°C	-40.0 to +140.0°F	0.1°C	0.1°F		
		P36	JIS '89 JPt100 (JIS Pt100)	-50.0 to +200.0°C	-50.0 to +400.0°F	0.1°C	0.1°F		
		P46	JIS '89 JPt100 (JIS Pt100)	-199.9 to +200.0°C	-300.0 to +400.0°F	0.1°C	1°F		
		C01	Current 4 to 20mA dc linear	Programmable	-1999 to +9999	-	-	±0.2% FS	Possible
		M01	Voltage 0 to 10mA dc linear	Programmable	-1999 to +9999	-	-		
		V01	Voltage 1 to 5V dc linear	Programmable	-1999 to +9999	-	-		
		L02	Voltage -10 to +10mV dc linear	Programmable	-1999 to +9999	-	-		
IV	Power	A	90 to 264 Vac 50-60Hz						
		E	90 to 264 Vac 50-60Hz (Honeywell version, DCP 216 only)						
V	Optional function (1)		Auxiliary output (4 to 20mA dc)	Autotuning	RS-422 Communications	RS-232C Communications			
		000	-	-	-	-			
		001	○	-	-	-			
		002	-	○	-	-			
		003	○	○	-	-			
		004	-	○	○	-			
		005	-	○	-	○			
		006	○	○	○	-			
007	○	○	-	○					
VI	Optional function (2) DCP211	01	None						
		D1	With test data						
		T1	Tropical treatment						
		B1	Tropical treatment with test data.						
	(2) DCP216	00	None						
		D0	With test data						
		T0	Tropical treatment						
		B0	Tropical treatment with test data.						

Note: ○ = corresponding function is included.

SPECIFICATIONS

Program storage capacity	No. of patterns	7 patterns (DCP 211), 19 (DCP 216)			
	No. of segments per program	20 segments			
	No. of segments for all programs	140 segments (DCP 211), 380 (DCP 216)			
	No. of events for all programs	DCP 211	200 events		Total number of PV, deviation, RUN, READY, END and timer events.
	DCP 216	200 events total in program Nos. 1 to 7 200 events total in program Nos. 8 to 14 200 events total in program Nos. 15 to 19			
Indication and setting	Indication and setting resolution	See the model selection guide.			
	Indication accuracy	$\pm 0.2\%$ FS $\pm 1U$ $\pm 5.0\%$ FS at 260°C max. for T/C B type. (U: Industrial unit). $\pm 0.3\%$ for D type.			
	Indication and setting resolution	See the model selection guide.			
	Time units	0 to 99 hours 59 min. or 0 to 99 min 59 sec			
Remote operation switch ass'y (Contact input)	Input sampling cycle	500 msec			
	Type of input	Thermocouple	RTD (100 ohm pt)	Current	Voltage
	Impedance	1M Ω min.	—	100	1M Ω min.
	Allowable wiring resistance	250 Ω max.	4 Ω max.	—	—
	Input circuit failure indication	Upscale (Regarded as 110%)	Upscale (when element broken)	Downscale (Regarded as -10%)	—
	Digital filter	System: first-order lag filter Time constant: 0.0 to 120.0 sec variable (0.0: filter off.)			
	PV bias	-100 to +100U variable			
	Control system	PID control system, deviation value derivative type			
Control	Proportional band (P)	0.1 to 999.9% FS; Resolution: 0.1% (ON/OFF control at P=0)			
	Integral time (Reset time) (I)	0 to 3600 sec; Resolution: 1 sec (PD control at I=0)			
	Derivative time (Rate time) (D)	0 to 1200 sec; Resolution: 1 sec (PI control at D=0)			
	Direct/reverse action	Selectable			
	Output type	Relay output	Voltage output	Current output	
	Control mode	Time proportional PID RD+MR or ON-OFF	Time proportional PID PD+MR or ON-OFF	Current proportional PID or PD+MR	
	Output ratings	SPDT 250V ac 5A resistive load	22.5V DC $\pm 10\%$ Lower than 75mA	4 to 20mA dc (2.4 to 21.6mA dc)	
	Cycle time	5 to 120 sec	1 to 60 sec	—	
	Allowable load resistance	—	—	600 Ω max.	
	Scaling	—	—	For SP output, -1999 to 9999, settable	
	Output sampling cycle	Renewed every 500 msec			
Remote Operation (Contact input)	No. of inputs	8 contacts, Dry contact input			
	Program selection	DCP 211	3 contacts, Program number selection (2 ⁰ , 2 ¹ , 2 ²) Up to 7 programs		
		DCP 216	5 contacts, Program number selection (2 ⁰ , 2 ¹ , 2 ² , 2 ³ , 10) Up to 19 programs		
	Program operation	DCP 211	5 contacts (operation start 1, Hold 1, Reset 1, Advance 1, Auto-tuning 1)		
DCP 216		4 contacts (operation start 1, Hold 1, Reset 1, Auto/Manual changeover 1) (Note 1)			
Event output	Setting type	PV, deviation, RUN, READY, END, time			
	Setting range	PV: 0 to 100% FS Deviation: -50 to +50% FS Time: 0 to 99.99 (in time unit)			
	Differential gap	0 to 100U			
	Output	PV, deviation, RUN, READY : Relay contact (reversible) SPST x 2 Time, END : Transistor open collector ... 4 outputs (Power supply: 24V dc, 100mA dc max., user-supplied)			
	Relay contact ratings	250V ac, 5A resistive load (PV, deviation)			

Auxiliary output (Optional function)	Output	PV or SP: 4 to 20mA		
	Scaling	PV and SP: Select -1999 to +9999		
	Allowable load resistance	600Ω max.		
Communication function RS-422 (Optional function)	Communication system	Network	1 to 16 units max. multidropped (slave mode only)	
		Mode	Half-duplex	
		Synchronization	Start/stop	
	Interface system	Transmission	Balanced (differential) type	
		Type	Serial	
		Signal line	3 transmit/receive lines	
		Transmission speed	1200, 2400, 4800, 9600 bps	
		Communication distance	300 m max.	
	Message character	Others	Conforms to RS-422	
		Character configuration	11 bits/character	
		Format	1 start, 2 stop bits (standard)	
Data length		8-bit binary		
Auxiliary output (Optional function)	Communication system	Network	Peer-to-peer (slave mode only)	
		Mode	Half-duplex	
		Synchronization	Start/stop	
	Interface system	Transmission	Unbalanced type	
		Type	Serial	
		Signal line	3 transmit/receive lines	
		Transmission speed	1200, 2400, 4800, 9600 bps	
		Communication distance	15 m max.	
	Message character	Others	Conforms to RS-232C	
		Character configuration	11 bits/character	
		Format	1 start, 2 stop bits (standard)	
Data length		8-bit ASCII		
General specifications	Power voltage	90 to 264V ac 50/60Hz		
	Power consumption	Max. 17.5VA		
	Insulation resistance	Higher than 50MΩ, 500V dc megger (between power terminal and case)		
	Dielectric strength	1500V ac for 1 min. or 1800V ac for 1 sec (between power terminal and case)		
	Weight	1.0 kg		
	Allowable ambient temperature	0 to 50°C		
	Allowable ambient humidity	10 to 90%RH (non-condensing)		
	Vibration resistance	0.5G max. (10 to 60Hz, XYZ directions, 2 hours each)		
	Shock resistance	50G max.		
Memory backup	Lithium battery (longer than 5 years)			

Note: 1. If A/M changeover by a remote switch is enabled by setup, the maximum number of programs selectable by a remote switch is 15.

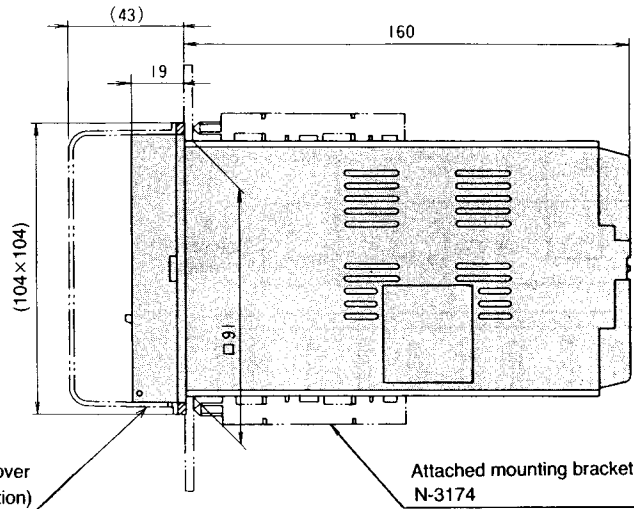
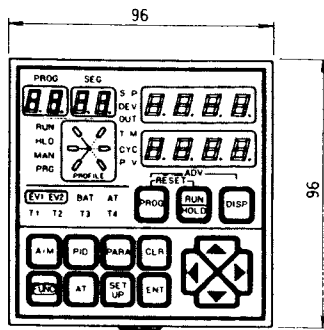

Packing, dust cover
81401330A (option)

Attached mounting bracket
N-3174

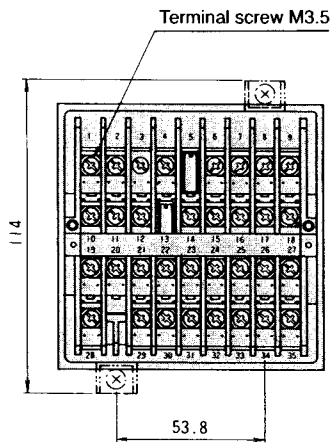

Panel cutout

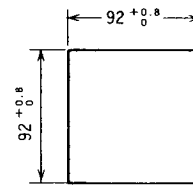

Panel cutout

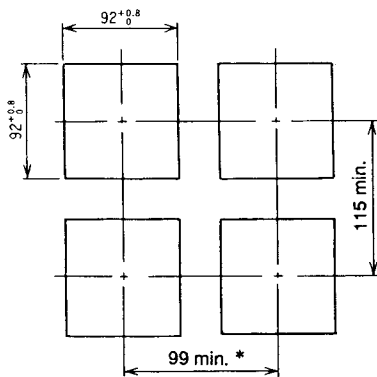

*120 min. when dust cover is used.

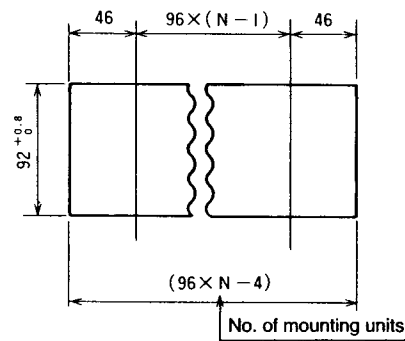

Panel cutout for closed mounting
(recommended)

External terminal layout

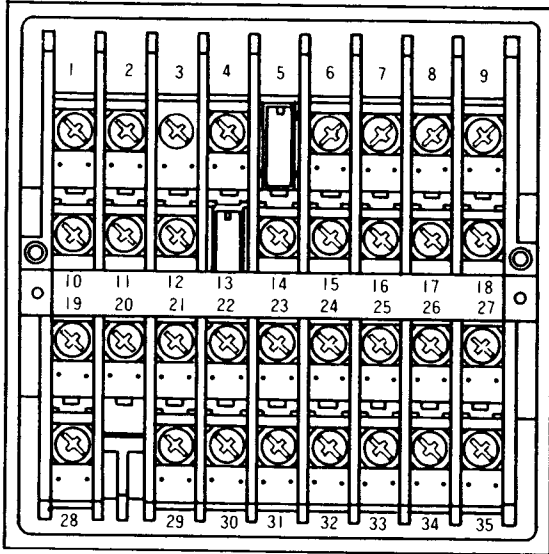
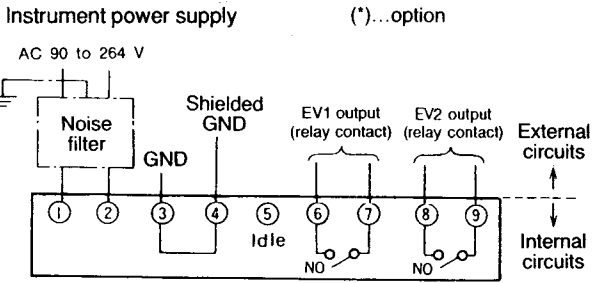

Control output (MV)

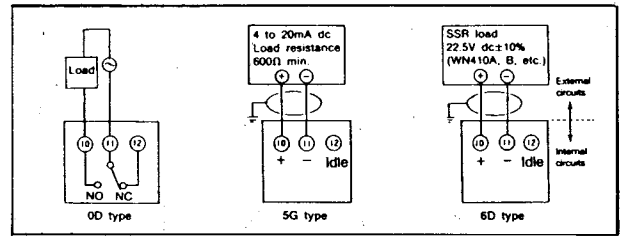

Communication COMM (*) Input/Output

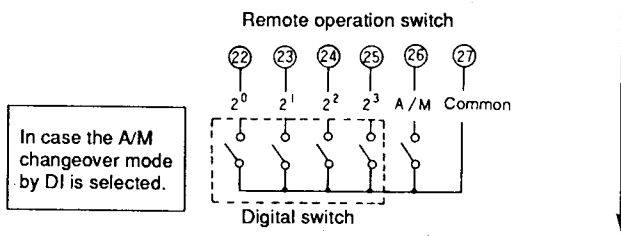
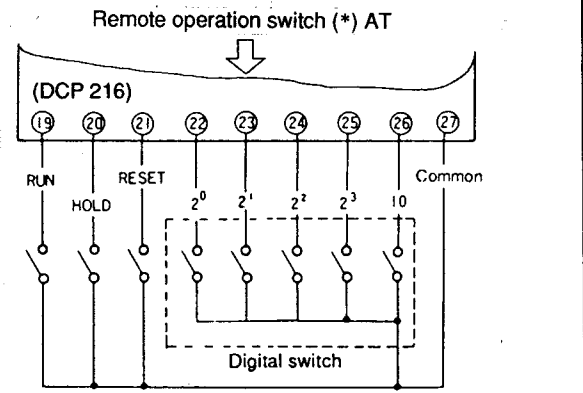
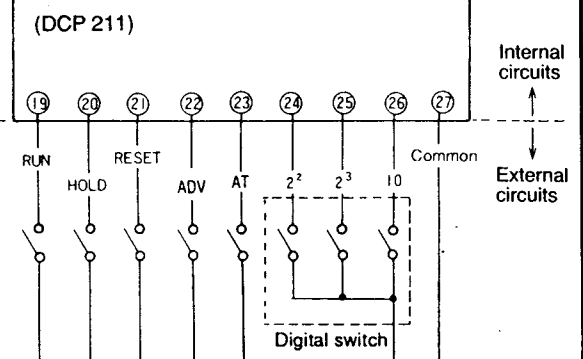
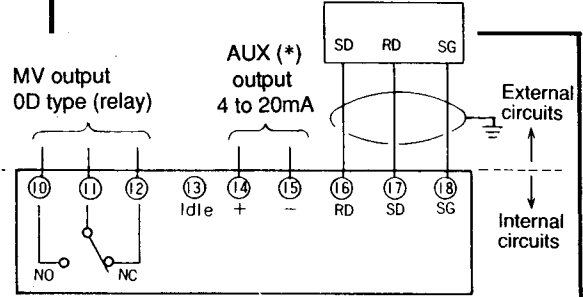

PV input and time event output

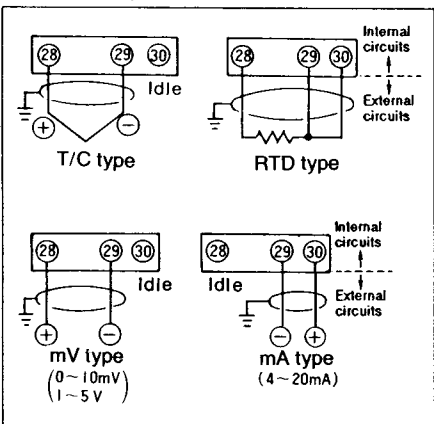
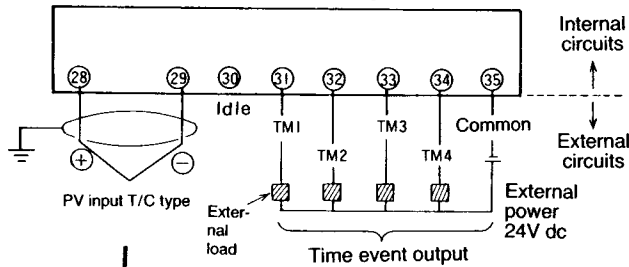

Communications (*)

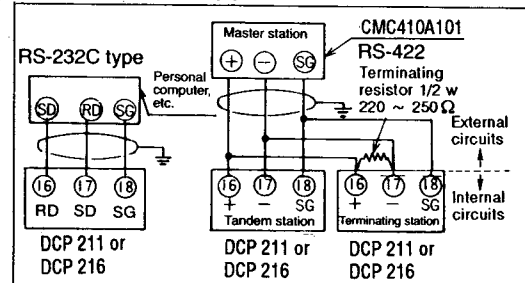

Specifications are subject to change without notice.

YAMATAKE

Savemation

Yamatake Corporation

Control Products Division

1-12-2, Kawana

Fujisawa, Kanagawa, 251-8522, Japan

Phone: 81-466-20-2187

Fax: 81-466-20-2309

Printed in Japan. (H)

1st Edition: Issued in May, 1994

2nd Edition: Issued in Nov., 1999