

DigitroniK Digital Program Controller DCP211

User's Manual

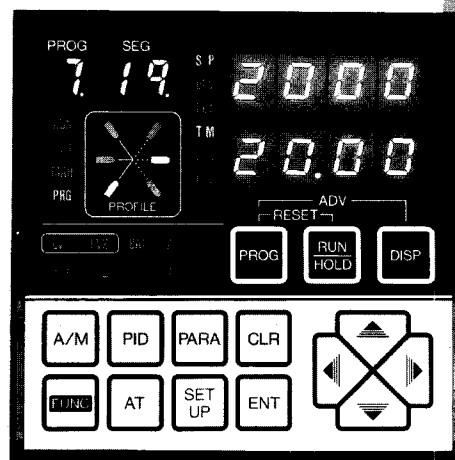

Yamatake Corporation

RESTRICTIONS ON USE

When using this product in applications that require particular safety or when using this product in important facilities, pay attention to the safety of the overall system and equipment. For example, install fail-safe mechanisms, carry out redundancy checks and periodic inspections, and adopt other appropriate safety measures as required.

REQUEST

Make sure that this Instruction Manual is handed over to the user before the product is used.

Copying or duplicating this Instruction Manual in part or in whole is forbidden. The information and specifications in this Instruction Manual are subject to change without notice.

Considerable effort has been made to ensure that this Instruction Manual is free from inaccuracies and omissions.

If you should find any inaccuracies or omissions, please contact Yamatake Corporation.

In no event is Yamatake Corporation liable to anyone for any indirect, special or consequential damages as a result of using this product.

©1988 Yamatake Corporation ALL RIGHTS RESERVED

The DigitroniK® is a registered trademark of Yamatake Corporation.

This manual describes how to use this product. Before using this product, thoroughly read and understand the descriptions in this manual to ensure correct use.

After you have read this manual, store the manual a safe place nearby so that it can be referred whenever needed.

WARNINGS

- Before connecting or disconnecting wiring to or from this product, be sure to turn the mains power supply OFF. Inadvertently touching terminals or other electrically live parts might cause electrical shock.
- Before connecting this product to the measurement target or external control circuits, make sure that it is connected to an earth. Failure to do so might cause electrical shock or fire.

CAUTIONS

- Wire this product properly in accordance with predetermined wiring standards, instruction described in this manual and generally accepted wiring methods. Failure to do so might result in electrical shock, fire or malfunction.
- Use this product only within the recommended operating conditions (temperature, humidity, voltage, vibration, shock, atmosphere, etc.) described in the specifications.
- Do not cover the ventilation holes on this product. Doing so might result in fire or malfunction.
- Do not disassemble this product, or touch parts inside. Doing so might result in electrical shock or malfunction.
- Some parts in this product become hot while the power is turned ON or are hot immediately after the power is turned OFF. Do not touch these parts. Doing so might result in burns.
- Do not operate the operation keys on this product with the top of a propelling pencil or other sharp-tipper object. Doing so might result in malfunction.

SAFETY REQUIREMENTS



To reduce risk of electrical shock which could cause personal injury, follow all safety notices in this documentation.



This symbol warns the user of a potential shock hazard where hazardous live voltages may be accessible.

- * If the equipment is used in a manner not specified by the manufacturer, the protection provided by the equipment must be impaired.
- * Do not replace any component (or part) not explicitly specified as replaceable by your supplier.
- * All wiring must be in accordance with local norms and carried out by authorized experienced personnel.
- * The ground terminal must be connected before any other wiring (and disconnect last).
- * A switch in the main supply is required near the equipment.
- * Mains power supply wiring requires a (T) 2A, 250V fuse(s).

Installation category : Category II (IEC664-1, IEC1010-1)

Specification of common mode voltage : The common mode voltages of all I/O except for main supply and relay outputs are less than 30Vrms, 42.4Vpeak and 60Vdc.

EQUIPMENT RATINGS

Supply voltage	90 - 264 V~
Frequency	50/60Hz
Power or current ratings	17.5VA maximum

EQUIPMENT CONDITIONS

Do not operate the instrument in the presence of flammable liquids or vapors. Operation of any electrical instrument in such an environment constitutes a safety hazard.

Temperature	0 to 50°C
Humidity	10 to 90% RH
Vibration	Frequency 10 to 60Hz
	Acceleration 2 m/s ² maximum

EQUIPMENT INSTALLATION

The controller must be mounted into a panel to limit operator access to the rear terminals.

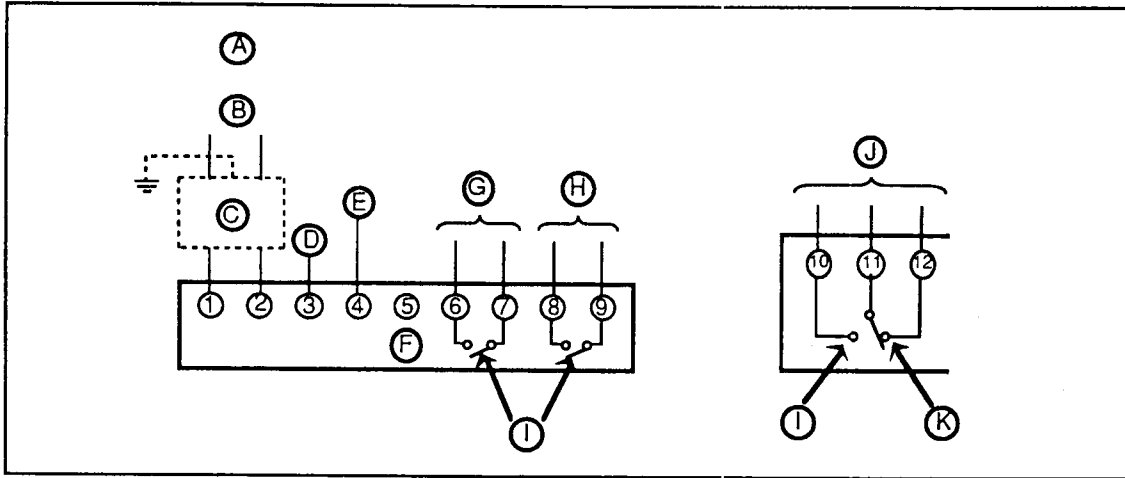

(A)	Instrument power supply
(B)	90 to 264 V AC
(C)	Noise filter
(D)	GND
(E)	Shielded GND
(F)	Idle
(G)	Event 1 output (relay contact)
(H)	Event 2 output (relay contact)
(I)	Normally open
(J)	Relay output
(K)	Normally close

TABLE OF CONTENTS

I.	MODEL SELECTION GUIDE AND SPECIFICATIONS	1
II.	FUNCTION	4
1.	GENERAL	4
2.	CONSTANTS AND PROGRAMMING	5
3.	CONTENT OF PROGRAM	7
	A. MAIN FUNCTION	7
	(1) SOAK SEGMENT	7
	(2) RAMP SEGMENT	7
	B. SUBFUNCTION	8
	(1) PROCESS VARIABLE-BASED EVENT CIRCUITS	8
	(2) DEVIATION-BASED EVENT CIRCUITS	9
	(3) TIME-BASED EVENT CIRCUITS	10
	(4) PID GROUP SELECTION	11
	(5) GUARANTEED SOAK	12
	(6) PV START	12
	(7) AUTOMATIC CYCLING OF A PROGRAM	13
III.	PROGRAMMING AND OPERATION	14
1.	CONTENTS OF DISPLAYS AND FUNCTIONS OF KEYS	14
2.	OUTLINE OF PROGRAMMING	17
3.	SETUP MODE	18
4.	PARAMETER MODE	24
5.	PROGRAMMING MODE	27
	(1) PROGRAMMING MAP	28
	(2) MAIN FUNCTION SETTING	29
	(3) SUBFUNCTION SETTING	32
6.	PID TUNING	36
7.	OPERATION MODE	38
	<OPERATION EXAMPLES>	39
	① STARTING A PROGRAM	39
	② STARTING A PROGRAM FROM A PRESENT TEMPERATURE	39
	③ HOLDING A PROGRAM	39
	④ ADVANCING A PROGRAM TO A NEW SEGMENT	39
	⑤ STARTING AUTO TUNING	40
	⑥ SELECTING MANUAL CONTROL FOR THE PROCESS	40
	⑦ STOPPING A PROGRAM	41
	⑧ COPYING STORED PROGRAM DATA UNDER A DIFFERENT PROGRAM NUMBER	41
	⑨ CHANGING PROGRAM DATA	41
	⑩ STORING THE SETTING RANGE LIMITS OF A PROGRAM	42
	⑪ DELETING STORED DATA	42
	⑫ ALARM CODE DISPLAY	42
	⑬ CONDITION AFTER RECOVERY FROM A POWER FAILURE	42
8.	REMOTE OPERATION	43
9.	EXTERNAL DIMENSIONS	44
10.	INSTALLATION	45
11.	WIRING	46
12.	EXTERNAL WIRING DIAGRAM	48
13.	MAINTENANCE	50
14.	APPENDIXES	51
	(1) PROGRAM PREPARATION EXAMPLE	52
	(2) SETUP SETTING EXAMPLE	53
	(3) PARAMETER SETTING EXAMPLE	53
	(4) PROGRAMMING EXAMPLE	54
	PROGRAM WORK SHEET	

I. MODEL SELECTION GUIDE AND SPECIFICATIONS

Model selection guide

I II III IV V VI

Example :

I II III IV V VI
 DCP216 5G K09 A 007 00

Code No.	Model No.	Specifications						
I	Basic model number DCP 216	Digital program controller						
II	Output type Control mode	0D	Relay output SPDT (ON-OFF) Time proportional PID					
		5G	Current output 4 to 20mA DC Continuous proportional PID					
		6D	Voltage output 22.5V DC + 10% (ON-OFF) Time proportional PID					
III	Type of input range		Type of input	Range		PV range code	Accuracy	Range change
		T44	Thermocouple T (CC)	-199.9 to +300.0°C	-300 to +700°F	6	+0.2% FS	Possible
		J08	Thermocouple J (IC)	0 to 800°C	0 to 1600°F	2		
		E08	Thermocouple E (CRC)	0 to 800°C	0 to 1800°F	1		
		K04	Thermocouple K (CA)	0.0 to 400.0°C	0 to 750°F	12		
		K08	Thermocouple K (CA)	0 to 800°C	0 to 1600°F	11		
		K09	Thermocouple K (CA)	0 to 1200°C	0 to 2400°F	3		
		U13	Thermocouple N	0 to 1300°C	32 to 2372°F	9		
		Y13	Thermocouple PL II	0 to 1300°C	32 to 2372°F	10		
		R16	Thermocouple R (PR13)	0 to 1600°C	0 to 3100°F	4		
		S16	Thermocouple S (PR10)	0 to 1600°C	0 to 3100°F	5		
		B18	Thermocouple B (PR30-6)	0 to 1800°C	0 to 3300°F	0		
		D19	Thermocouple PR40-20	0 to 1900°C	(0 to 3400°F)	8	+0.3% FS	Possible
		W23	Thermocouple W (Wre5-26)	0 to 2300°C	0 to 4200°F	7	+0.2% FS	
		Z13	Thermocouple Ni=NiMo	0 to 1300°C	32 to 2372°F	16	+0.2% FS	
		F01	Pt100 (IEC, DIN and JIS)	0.0 to 100.0°C	0.0 to 200.0°F	34	+0.2% FS	
		F03	Pt100 (IEC, DIN and JIS)	0.0 to 300.0°C	0.0 to 500.0°F	33		
		F05	Pt100 (IEC, DIN and JIS)	0.0 to 500.0°C	0 to 900°F	29		
		F32	Pt100 (IEC, DIN and JIS)	-100.0 to +150.0°C	-150.0 to +300.0°F	32		
		F33	Pt100 (IEC, DIN and JIS)	-40.0 to + 60.0°C	-40.0 to +140.0°F	30		
		F36	Pt100 (IEC, DIN and JIS)	-50.0 to +200.0°C	-50.0 to +400.0°F	31		
		F46	Pt100 (IEC, DIN and JIS)	-199.9 to +200.0°C	-300.0 to +400.0°F	21		
		F50	Pt100 (IEC, DIN and JIS)	-200 to +500°C	-300.0 to +900.0°F	20		
		P01	JPt100 (JIS Pt100)	0.0 to 100.0°C	0.0 to 200.0°F	28		
		P03	JPt100 (JIS Pt100)	0.0 to 300.0°C	0.0 to 500.0°F	27		
		P05	JPt100 (JIS Pt100)	0.0 to 500.0°C	0 to 900.0°F	23		
		P32	JPt100 (JIS Pt100)	-100.0 to +150.0°C	-150.0 to +300.0°F	26		
		P33	JPt100 (JIS Pt100)	-40.0 to + 60.0°C	-40.0 to +140.0°F	24		
		P36	JPt100 (JIS Pt100)	-50.0 to +200.0°C	-50.0 to +400.0°F	25		
		P46	JPt100 (JIS Pt100)	-199.9 to +200.0°C	-300.0 to +400.0°F	22		
		C01	Current 4 to 20mA DC linear	Programmable	-1999 to 9999	40	+0.2% FS	Possible
		M01	Voltage 0 to 10mV DC linear	Programmable	-1999 to 9999	41		
		V01	Voltage 1 to 5V DC linear	Programmable	-1999 to 9999	45		
L02	Voltage -10 to 10mV DC linear	Programmable	-1999 to 9999	42				
IV	Power	A	90 to 264V AC 50-60Hz					
V	Optional function (1)		Auxiliary output (4 to 20mA DC)	Auto tuning	RS-422 Communication	RS-232C Communication		
		000	—	—	—	—		
		001	○	—	—	—		
		002	—	○	—	—		
		003	○	—	—	—		
		004	—	○	○	—		
		005	—	○	—	○		
		006	○	○	○	—		
VI	Optional function (2)	01	Data are not attached					
		D1	Data are attached					
		T1	Tropical treatment					
		B1	Data are attached plus tropical treatment					
		Y1	Traceability prover compatibility product					

(Note) Mark ○ shows that the corresponding function is provided.

SPECIFICATIONS

Program storage capacity	No. of programs	7 programs			
	No. of segments per program	20 segments			
	No. of segments for all programs	140 segments			
	No. of events for all programs	200 event settings (total number of PV, deviation, RUN, READY, END, and time-based events circuits)			
Indication and setting	Indication and setting ranges	See the model selection guide.			
	Indication accuracy	$\pm 0.2\%$ FS $\pm 1U$ $\pm 5.0\%$ FS at 260°C max. in case of T/C B type. (U: Industrial unit)			
	Indication and setting resolution	See the model selection guide			
	Time units	0 to 99 h 59 min, or 0 to 99 min 59 s			
Input	Input sampling cycle	500 ms			
	Type of input	Thermocouple	RTD (100 ohm pt)	Current	Voltage
	Impedance	1M Ω min.	—	100 Ω	1M Ω min.
	Allowable wiring resistance	250 Ω max.	4 Ω max.	—	—
	Input circuit failure indication	Upscale (Regarded as 110%)	Upscale (When the element was broken)	Downscale (Regarded as -10%)	—
	Digital filter	System: First-order lag filter Time constant: 0.0 to 120.0 sec variable (0.0: filter off.)			
	PV bias	-100 to +100U variable			
Control	Control system	PID control system, deviation value derivative type			
	Proportional band (P)	0.1 to 999.9% FS, Resolution 0.1%, (ON-OFF control at P=0)			
	Integral time (Reset time) (I)	0 to 3600 s, Resolution 1 s, (PD control at I=0)			
	Derivative time (Rate time) (D)	0 to 1200 s, Resolution 1 s, (PI control at D=0)			
	Direct/reverse action	Selectable by set-up			
	Output type	Relay output	Voltage output:	Current output	
	Control mode	Time proportional PID PD+MR or ON-OFF	Time proportional PID PD+MR or ON-OFF	Current proportional PID or PD+MR	
	Output ratings	SPDT 250 V ac 5 A resistive load	22.5 V dc $\pm 10\%$ Lower than 75 mA	4 to 20 mA dc (2.4 to 21.6 mA dc)	
	Cycle time	5 to 120 s	1 to 60 s	—	
	Allowable load resistance	—	—	600 Ω max.	
	Scaling	—	—	For SP output, -1999 to 9999, settable	
Output sampling cycle	Renewed every 500 ms				
Remote operation Switch ass'y (Contact input)	No. of inputs	8 contacts Dry contact input			
	Program selection	3 contacts Program number selection (2 ⁰ , 2 ¹ , 2 ²) No. 1 to 7 program selection			
	Program operation	5 contacts (Operation start ... 1, Hold ... 1, Reset ... 1, Advance ... 1, Auto tuning ... 1)			
Event output	Setting type	PV, deviation, RUN, READY, END, time			
	Setting range	PV: 0 to 100% FS Deviation: -50 to +50% FS Time: 0 to 99.59 (in time unit)			
	Differential gap	0 to 100U			
	Output	PV, deviation: Relay contact (reversible) SPST $\times 2$ Time: Transistor open collector ... 4 outputs (Power supply: 24 V dc, 100 mA dc max user-supplied)			
	Relay contact ratings	250 V ac, 5 A resistive load (PV, deviation)			
Auxiliary output (Optional function)	Output	PV or SP: 4 to 20 mA			
	Scaling	PV and SP: Settable -1999 to +9999			
	Allowable load resistance	600 Ω max.			

Communication function RS-422 (Optional function)	Communication system	Network	Multidrop system 1-to-16 units max. (Instrument serves as a slave station only)
		Information direction	Half-duplex
		Synchronous system	Start-stop synchronization
	Interface system	Transmission type	Balancing (differential) type
		Data line	Bit serial
		Signal line	3 transmitting/receiving lines
		Transmission speed	1200, 2400, 4800, 9600 bps
		Communication distance	300 m max.
	Message character	Others	Conforms to RS-422
		Character configuration	11 bits/character
		Format	1 start, 2 stop bits (standard)
	Communication function RS-232C (Optional function)	Communication system	Data code
Network			1-to-1 (Slave station function only)
Information direction			Half-duplex
Interface system		Synchronous system	Start-stop synchronization
		Transmission type	Unbalanced type
		Data line	Bit serial
		Signal line	3 transmitting/receiving lines
		Transmission speed	1200, 2400, 4800, 9600 bps
Message character		Communication distance	15 m max.
	Others	Conforms to RS-232C	
	Character configuration	11 bits/character	
Common specifications	Format	1 start, 2 stop bits (standard)	
	Data code	8 bit, ASCII code	
	Rated supply voltage/Frequency	100 to 240 V ac • 50/60 ± 2 Hz	
	Supply voltage/Frequency	90 to 264 V ac • 50/60 ± 4 Hz	
	Power consumption	Max. 17.5 VA	
	Insulation resistance	Higher than 50MΩ, 500 V dc megger (between power terminal and case)	
	Dielectric strength	1500 V ac for 1 min, or 1300 V ac for 1 s (between power terminal and case)	
	Mass	Approx. 1.0 kg	
	Allowable ambient temperature	0 to 50°C	
	Allowable ambient humidity	10 to 90%RH (No dew condensation is allowable)	
	Vibration resistance	4.9m/s ² max. (10 to 60 Hz XYZ directions 2 h each)	
	Shock resistance	490m/s ² max. (3 times each in vertical direction, in packed state)	
	Memory backup	Lithium battery (for longer than 5 years)	
	Environmental condition	Permanently connected equipment, indoor use, Panel mounted equipment	
	Conformed standard	EN61010-1, EN50081-2, EN50082-2	
Installation category (Over voltage category)	Category II (IEC664-1, EN61010-1)		
Pollution degree	Pollution degree 2		

II.

FUNCTION

1.

GENERAL

1. General

The DCP211 is a microprocessor-based program controller (96 mm×96 mm in size) which executes program control of temperature, humidity, pressure, flow, and other process variables.

2. Features

- Multiranges
Sensors can be replaced without any need of adjustment in each group of thermocouples, resistance thermometer bulbs, and linear inputs (current, voltage).
- SP limit
Since the DCP211 can limit a data setting range, it can prevent troubles due to wrong setting.
- Profile display
The DCP211 displays present segment conditions (rising, soaking, falling), and the next segment conditions during program run.
- Auto tuning (option)
Since the DCP211 automatically calculates PID constants at the start-up time, you can entrust the DCP211 with troublesome tuning.
- Free power supply.
Since the DCP211 is applicable to 90 to 264 V ac, it can be operated with any of 100, 110, 120, 200, 220, and 240 V ac power supply without reconnecting power terminals.

3. Outline of functions

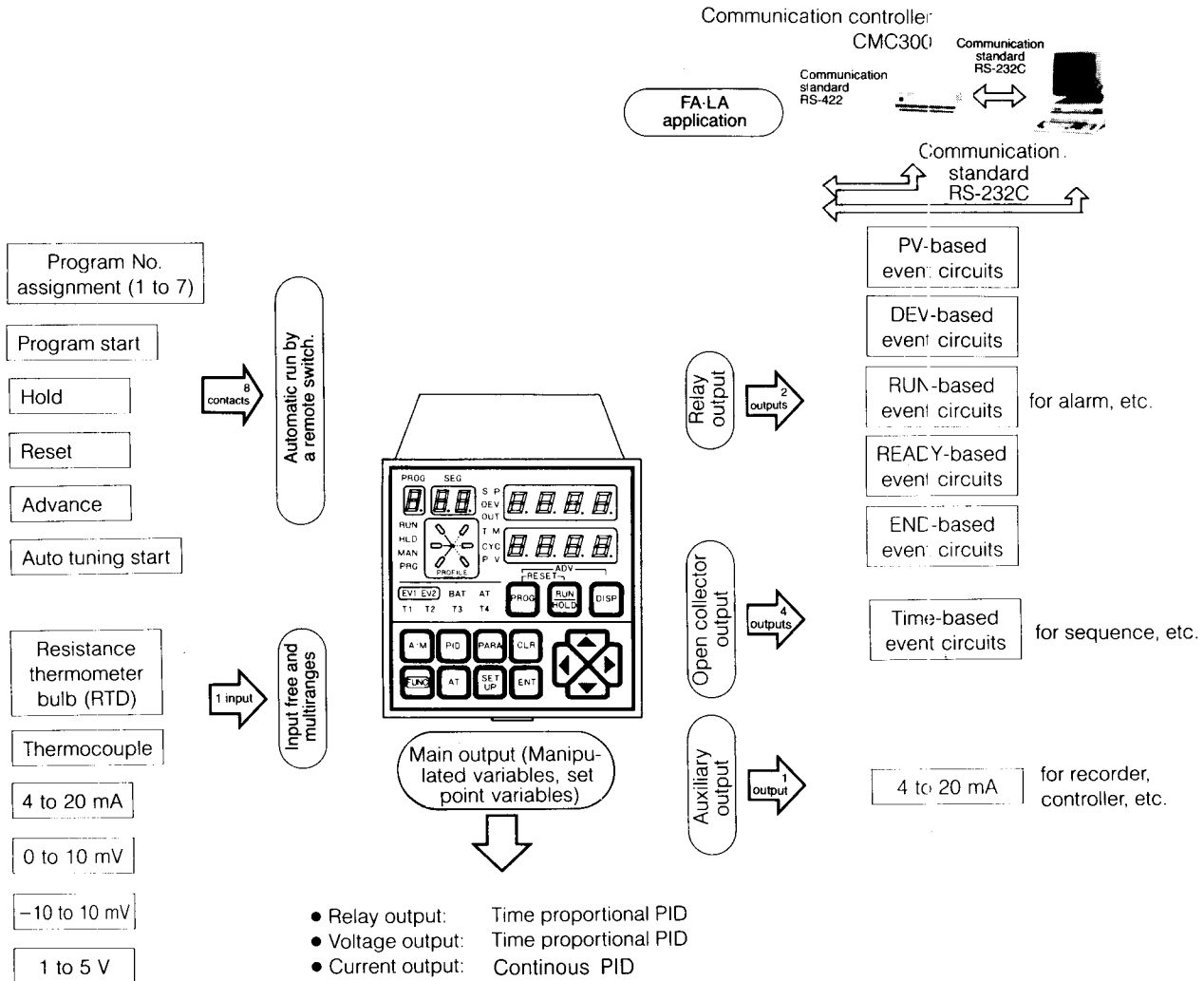

2. CONSTANTS AND PROGRAMMING

1. Content of program: DCP211 constants and programming

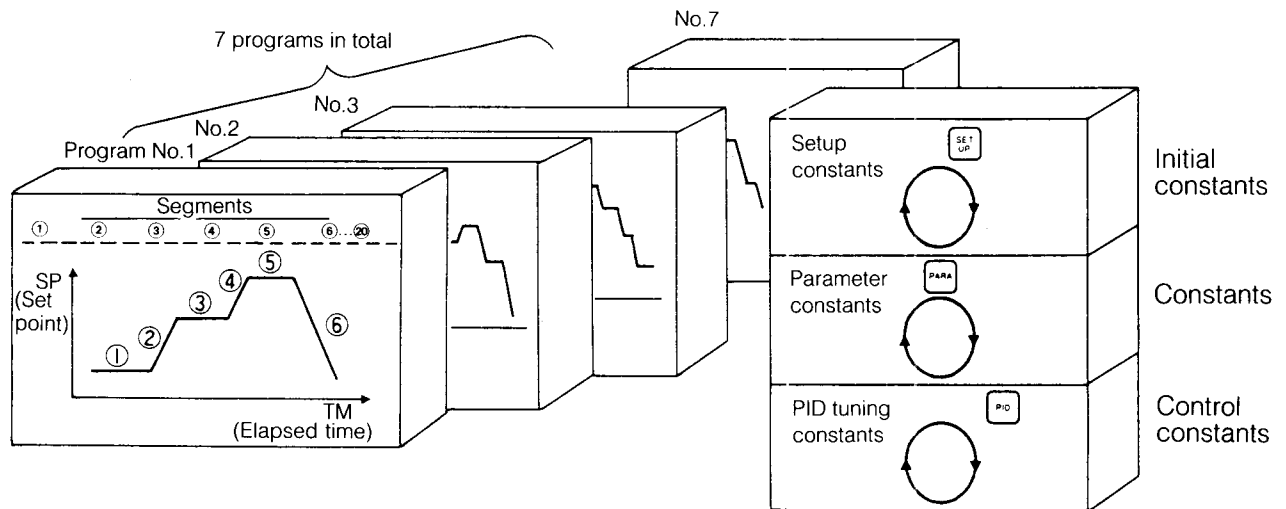

For running the DCP211, the above setting is necessary. Respective setting modes are provided.

(1) Setting of constants

Constants are divided into three groups, and operated by **SET UP**, **PARA**, and **PID** keys, respectively.

(a) Setup constants

Setup constants are initially set as a program controller. After setting, the constants are not changed frequently.

(b) Parameter constants

These constants are changed comparatively frequently.

(c) PID tuning constants

These constants are provided for PID control.

(2) Programming

Programs No.1 to 7 can be programmed. Max. 20 segments per program can be set.

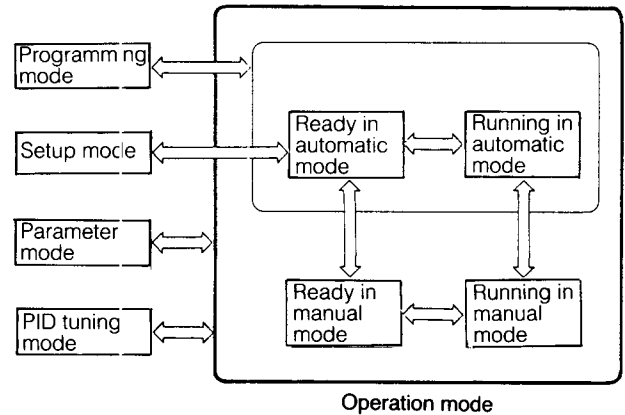

2. Programming:

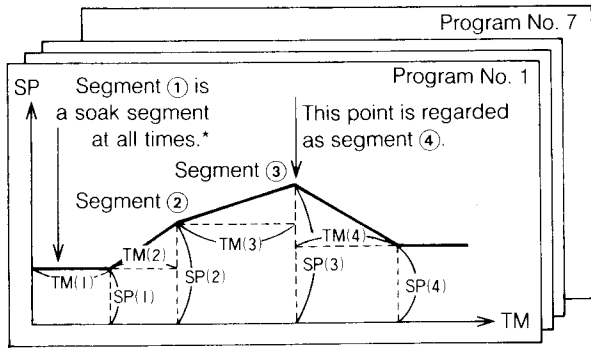
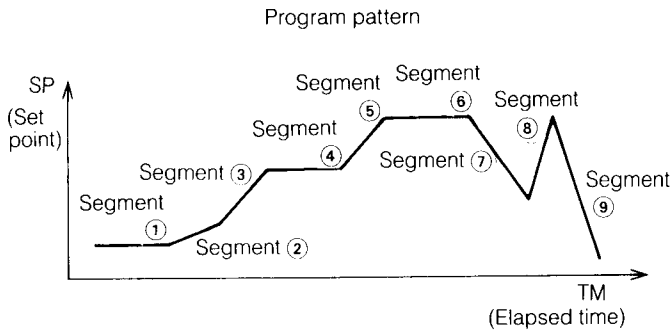

Fig. 2-1 Program concept

A broken line determined by set points of industrial values (temperature, humidity, pressure, flow, rotating speed, and other variables) to the time is called program pattern (or simply program or pattern).

Program patterns are identified from each other by program numbers (1 to 7).

Individual straight lines composing a program pattern are called segments, which are identified from each other by segment numbers (1 to 20).

A “—” portion of a segment is called soak (soaking), while a “/” portion is called ramp (rising or falling).

In the following figure, the n-th segment is specified by a set point of the N-1-th segment, N-th set point, and N-th time setting; provided that the first segment is regarded to be set constant.

The constant of the N-th segment and the N+1-th segment is regarded as the N+1-th start point.

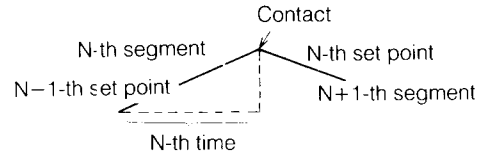

Program No. 1					
Segment 1		Segment 2		Segment 3	
Main function	Subfunction	Main function	Subfunction	Main function	Subfunction

- (1) Main function Sets a program pattern by set points and time.
 - ① Soak Setting of soaking section (every segment)
 - ② Ramp A rising or falling section to be set by the next aimed set point and arrival time (every segment).
- (2) Sub function Adds events and other functions.
 - ① Event (EV1, EV2) PV-based event circuits: Used for sending a sequence output by PV (every segment)
DEV-based event circuits: Used for sending a sequence output by a deviation between a set point and PV (every segment).
 - ② Time-based event circuits (T1, T2, T3, T4) Used for sending a sequence output by time (every segment).
 - ③ *Pid* Specifies the PID group number (every segment).
 - ④ Guaranteed soak (*G.S.*) Stops the progress of time until a process variable enters within the guaranteed soak band at the segment start point (every segment).
 - ⑤ PV start (*P.S.E.R*) Used for adjusting the start point to the point where PV is equal to a set point (every program).
 - ⑥ Cycle (*C.Y.C.L*) Used for repeating the same program.

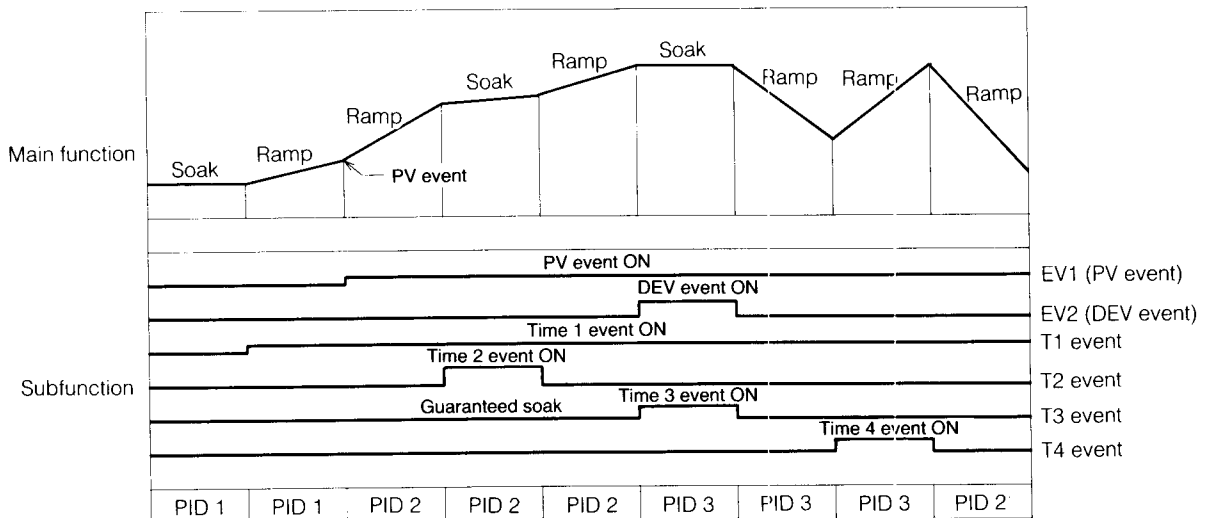

3.

CONTENT OF PROGRAM

A. Main function

(1) SOAK SEGMENT

- The soak means a section where SP is kept constant irrespective of the lapse of time.
- A program is set by specifying a set point and time of each segment. It is set by specifying an aimed set point in the segment and the time required to arrive at the aimed set point.

If the set point of the former segment is equal to that of the present segment in the program mode, the soak is set, and its time is set by the present segment time.

A set point and time of the first segment (segment No.1) of a program are set to soak at all times. If the time is set to zero, the set point becomes a point.

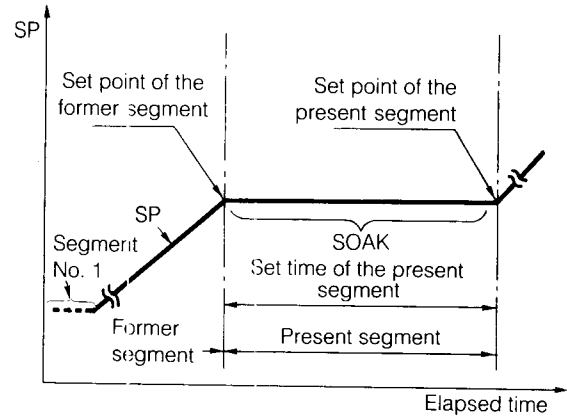

(2) RAMP SEGMENT

- The ramp means a section where a set point changes at a constant ratio with time.
- The first segment (segment No.1) of a program cannot be set to any ramp segment.

The ramp angle α is obtained by dividing a difference between set point SP1 of the former segment and set point SP2 of the present segment by the preset set time in the programming mode.

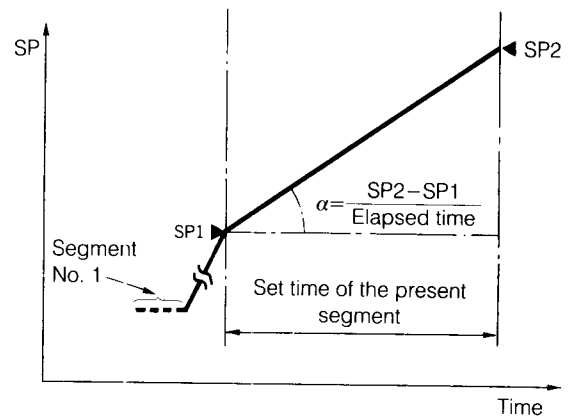

(2) Deviation-based event circuits

The DEV event (signal) circuit turns on if a PV value from a set point is deviated more than a certain value (DEV event set point), irrespective of the control output. The DEV event can be specified in any segment.

- The DEV event functions in RUN/HOLD mode.
- The DEV functions as follows.
 - Assume that DEV is set to be plus as viewed from SP;
 - The DEV event circuit turns on at (SP+DEV) point in direct action and turns off at (SP+DEV) point in reverse action as PV increases.
 - The DEV event circuit turns off at (SP+DEV - hysteresis) point in direct action, and turns on at (SP+DEV - hysteresis) point in reverse action as PV decreases.
 - Assume that DEV is set to the minus side as viewed from SP.
 - The DEV event circuit turns on at (SP-DEV) point in direct action, and turns off at (SP-DEV) point in reverse action as PV decreases.
 - The DEV event circuit turns off at (SP-DEV + hysteresis) point in direct action and turns on at (SP-DEV + hysteresis) point in reverse action as PV increases.
- The DEV event remains effective after it has been set once until the DEV event of the same event number is set again next. Accordingly, set the DEV event in the next segment as follows when you want to use this DEV event in a certain segment and make it ineffective in the next segment.
 - Set the direct action set point of +DEV to the upper limit of the input range.
 - Set the reverse action set point of -DEV to the upper limit of the input range.
 - Set the reverse action set point of +DEV to the lower limit of the input range.
 - Set the reverse action set point of -DEV to the lower limit of the input range.
- When the PV bias is set, a PV value obtained by adding or subtracting the PV bias value becomes effective to the DEV event.

1. Set the DEV event in the set up mode to the item to be displayed at the programming.
2. In parameter mode;
 - DEV event of EV 1 2 (direct action) setting
3 (reverse action) setting
 - DEV event of EV 2 2 (direct action) setting
3 (reverse action) setting
3. Set a DEV range value in programming mode.

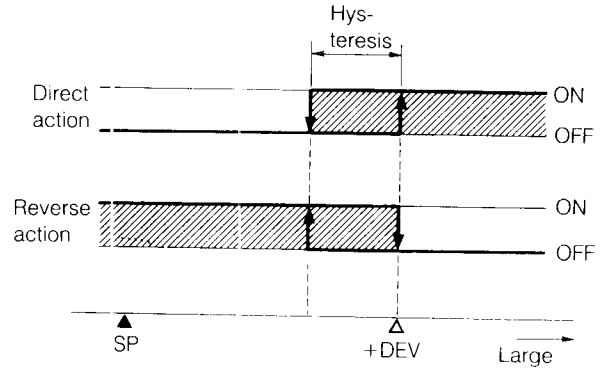
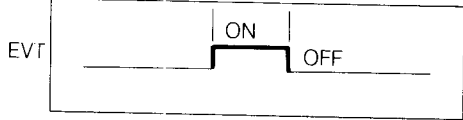
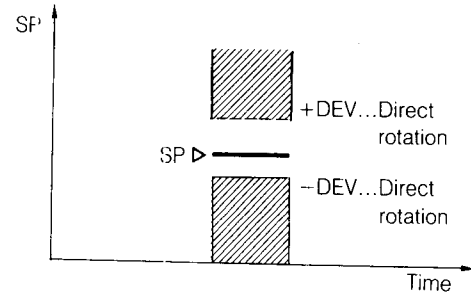

Assume that DEV is set to the plus side as viewed from SP.

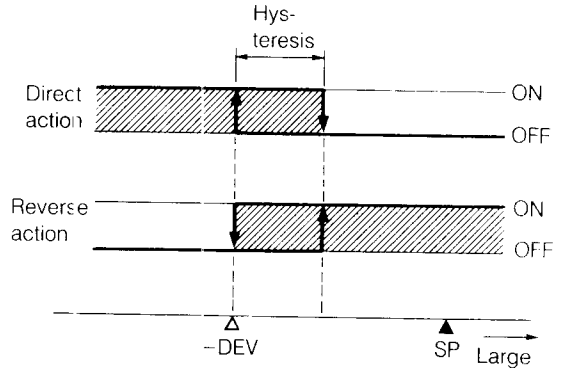

Assume that DEV is set to the minus side as viewed from SP.

Set in parameter mode.
 DEV: Direct action, reverse action
 H: Event, hysteresis
 Set in programming mode.
 DEV: DEV set point

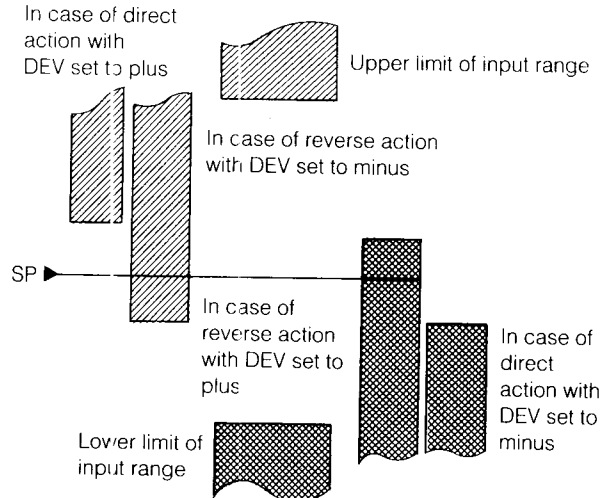

For making the DEV event ineffective in the next segment

(3) Time-based event circuits

- This time event circuit is a 4-channel transistor open collector output, and it turns on and off according to the lapse of the program time.
- The time event is settable in any segment. The on/off operation of each channel can be set by the time from the start point of the segment or the time exceeding the segment time can also be set. (If the time is set in excess of the final segment, the program is in READY mode after the program end, and the output turns off.)
- The ON and OFF action can be set once in one segment for each channel. Either on or off action only is also settable.
- The ON or OFF action is set independently each other.
- If the same setting (ON setting if the ON action is in progress, or OFF setting if the OFF action is in progress) is set in a subsequent segment again, the former setting becomes ineffective, while the latter setting becomes effective.

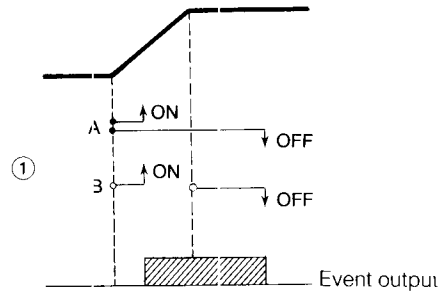
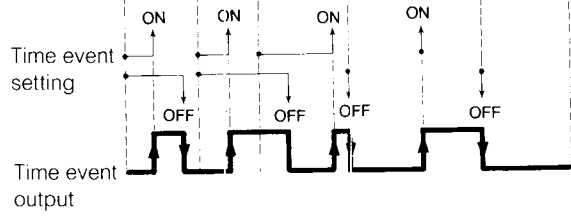
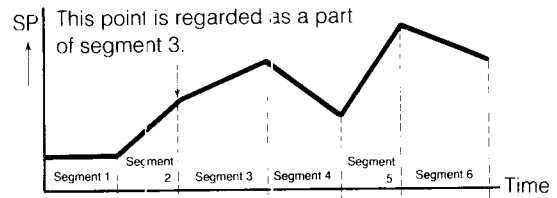

- The right figure No. ① shows that either A or B method is used to set the event output for the time event crossing a segment.

- The right figures ②, ③, ④, and ⑤ show the examples of the event output that the present time event is newly set to the former time event.
- Time event timer stops in HOLD mode.
- The switching point of two segments is regarded to belong to the latter segment.
- The time event is off in READY mode.

1. Set the time event in setup mode to the item to be displayed at the programming.
2. Set the ON time and OFF time of the time event in each segment in the programming mode.

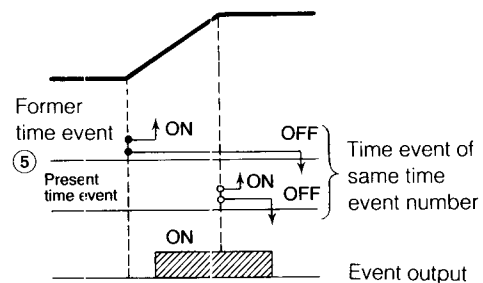
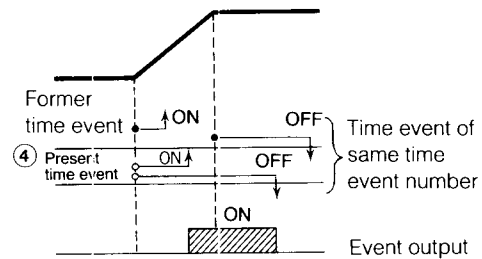
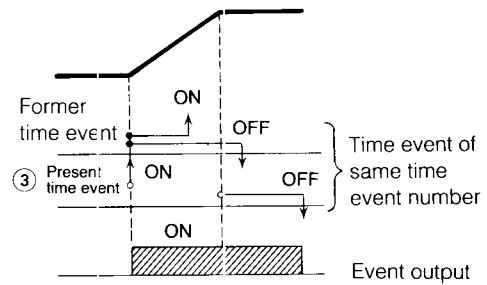
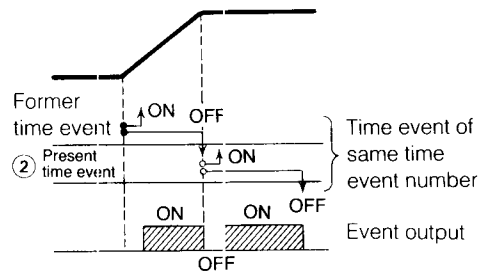

- When a segment is advanced to the next segment by the segment advance operation, the timer of the time event is corrected so that the same results can be obtained as in normal advance to the next segment without segment advance operation.

- If a power failure occurred, the time event is continued after recovery from the state just before the occurrence of the power failure.
- The time event turns off momentarily at the cycle switching point when cycle action is applied.
- When a program is transferred to segment 01 by cycle action, the time event setting and timer are cleared once, and they are reset and corrected to the same results as in normal start of the program with segment 01.

• Time event in PV start

If a program is started halfway in the course of a certain segment by the PV start operation, the time event setting and timer action are executed to be the same results as in the transfer to the halfway (the point found by the PV start) of the segment by normal start with segment 01 without PV start operation.

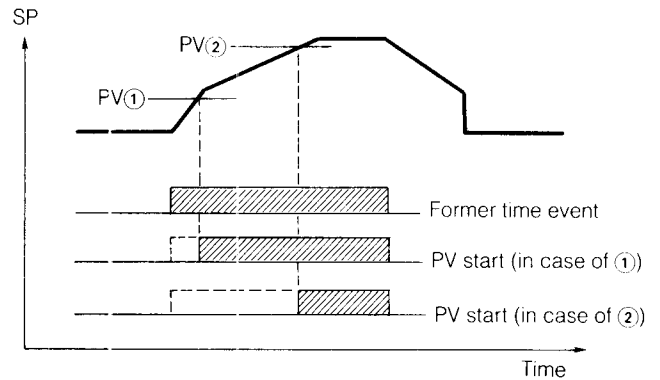

The time event at PV start is automatically corrected.

• Time event in guaranteed soak

The time event circuit turns on simultaneously when an SP enters the guarantee soak segment of a program when the ON time is "0", and the time measurement stops until the PV reaches the guaranteed soak temperature band. The time measurement is started with the time the PV has reached the guaranteed soak temperature band. Thus, the time compensation of the guaranteed soak segment can be synchronized with the time event time.

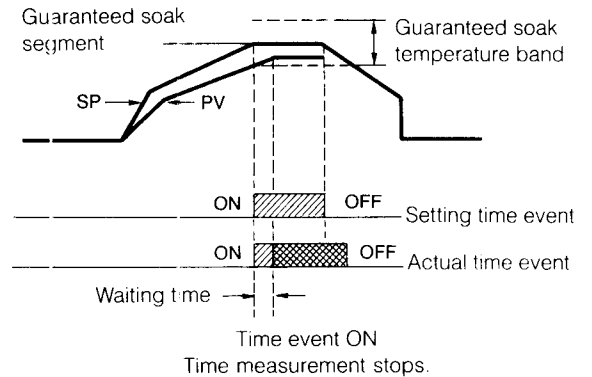

(4) PID group selection

- Three groups of PID parameters can be used for control operation, assuming that one group consists of P.I.D. and output limiters.
- A PID parameter group to be used for each segment is selectable during programming.
- PID groups are assignable in any segment.

1. Set PID in setup mode to the item to be displayed at the programming.
2. Set a PID group to be used in the programming mode.

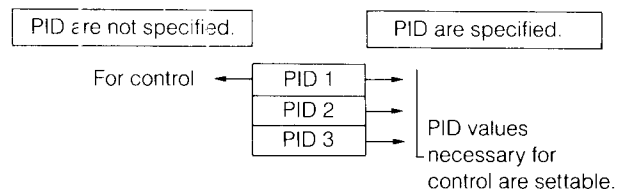

- One group of PID constant groups is selected at the delivery from factory.

(5) G.SOAK (guaranteed soak)

- The guaranteed soak means a section where the segment setting time is guaranteed without starting the segment setting time count until PV enters a predetermined band of SP.
- The G.SOAK time is started counting after a PV value has entered the soak band for more than one second. This is also applicable to the advance mode.
- Unlike events, the action is judged at the entry of the segment in which G.SOAK is set. This decision is irrespective of whether a PV value gets out of the G.SOAK band or not after it has entered the G.SOAK band once. This G.SOAK can also be set at the RAMP segment point. The action is judged at the entry of a RAMP segment in the same way as described above, and it is not executed during the RAMP segment time until PV enters a certain band of SP.

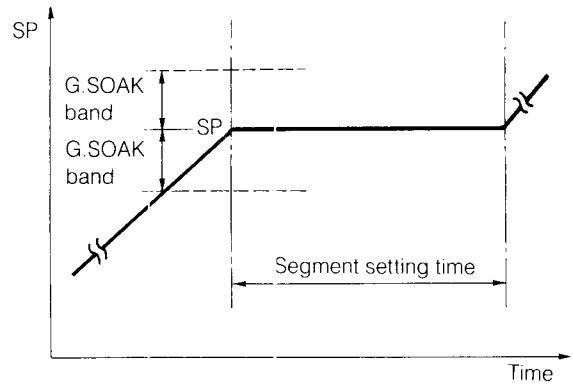

1. Set G.SOAK in the setup mode to the item to be displayed at the programming.
2. Set the G.SOAK band (numeric value) in the parameter mode.
3. Set whether G.SOAK is used or not in each segment of the programming mode.

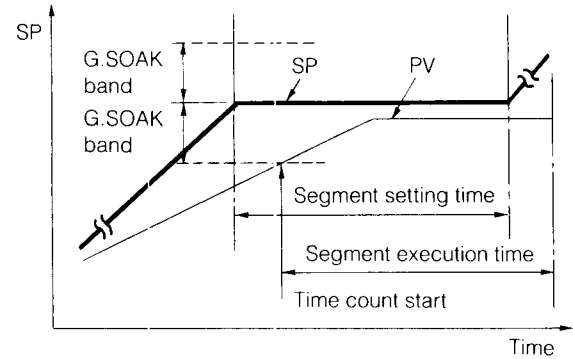

(6) PV start

Operation start from a PV value point on a program pattern

PV start function

- The PV start is made by normal RUN operation, if the PV start is set during programming.
- A program is started with the first point where the PV coincides with the SP of the program (PV and SP include a bias).
- A program is started with the beginning of No.1 segment, if PV and SP don't coincide with each other.
- After PV start, the event action and time event time are automatically corrected.

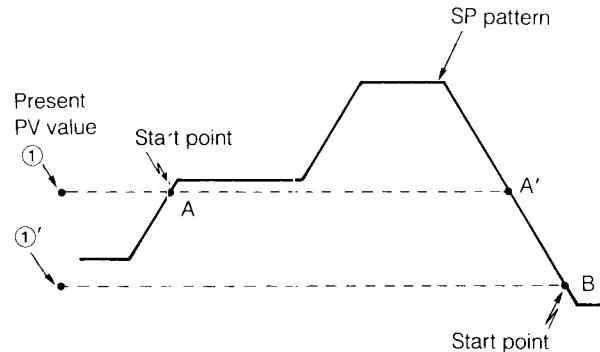

1. Set the PV start in the setup mode to the item to be displayed at the programming.
2. Set YES or NO to determine whether the program is PV started or not in the programming mode.

PV start point

- ① A program is started with the point (A) where a PV value coincides with an SP pattern: first.
- ①' Since the point (B) where a PV value coincides with an SP pattern first is positioned at the end of this program, the residual pattern only is program-controlled.

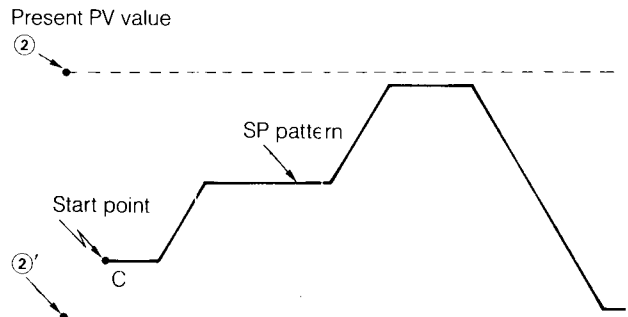

PV start point

- ②, ②' Since a PV value and an SP pattern don't coincide with each other, a program pattern is started with No.1 segment (C).

(7) Automatic cycling of a program

- This function repeats the program from No.1 segment of a complete program to the final segment by the number of preset cycles. The number of cycles is settable to max. 99 cycles every program.
- If No. of cycles is set to n, the program is repeated by n+1 times.
- Cycle run is restarted under the cleared condition of each event setting of PV, DEV, and time without running at the end point of the final segment.
- This run is started with segment 1 without executing any PV start, even if the PV start function is preset.

1. Set No. of cycles in the setup mode to the item to be displayed at the programming.
2. Set No. of cycles in the programming mode.

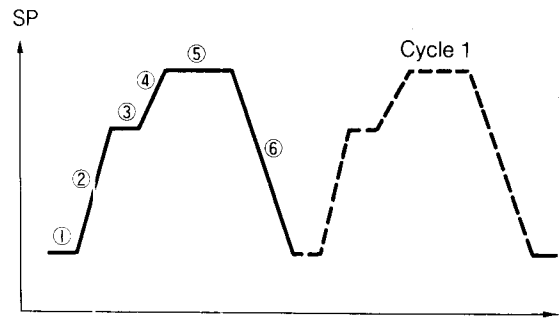

- No. of cycles to repeat the entire program can be set from any segment (① to ⑥).
- No. of cycles set is displayed in all segments.

III.

PROGRAMMING AND OPERATION

1. CONTENTS OF DISPLAYS AND FUNCTIONS OF KEYS

Contents of displays



Program No. display:
Displays a selected program No.
Displays A, if an alarm occurs.



Segment No. display:
Displays a selected segment No.
Displays an alarm code, if an alarm occurred.

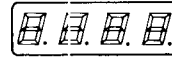

Upper display:
Displays SP, DEV, OUT, TIME, etc.

Upper and lower display indicators:
Indicates the contents of the upper and lower displays.

RUN
HLD
MAN
PRG

Mode indicator LED lamps:
Indicates RUN, HOLD, MAN, and programming modes.



Profile indicator LED lamp:
Indicates the rising, soaking, and falling tendencies of a program pattern by 2 segments.



Lower display:
Displays PV, TIME, CYC, etc.

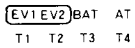

EV (event) indicator LED lamp:
Indicates the event action.
Indicates an event setting in programming mode.

BAT (battery) alarm LED lamp:
Flickers when the battery voltage becomes lower than specified.

AT (auto tuning) indicator LED lamp:
Flickers during the execution of auto tuning.

T1, T2, T3, T4 (time event) indicator LED lamps:
Indicates the event action.
Indicate an event setting in programming mode.

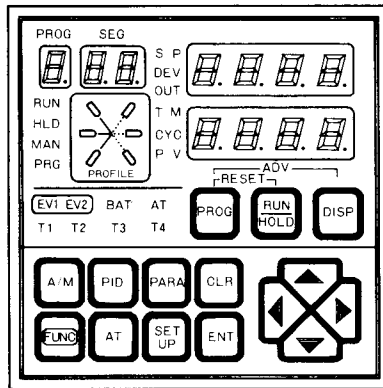

Functions of keys

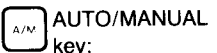

AUTO/MANUAL key:
Selects AUTO or MANUAL mode.



PID key:
Changes the setting of PID constants.



Parameter key:
Sets and changes parameter constants.



Clear key:
Deletes program data with FUNC key combined.



Function key:
Used together with other keys.



Auto tuning key:
Starts or interrupts the execution of auto tuning.



Set up key:
Sets setup constants.



Enter key:
•Used to change data.
•Enters data in memory.



RUN/HOLD key:
•Sets the mode from READY to FUN.
•Selects RUN or HOLD.



Display key:
•Changes the display selection.
•Interrupts the setting action, and other action.



Multi-keys:

- One of these 4 keys is used for data setting and programming item shift.
- These keys increase or decrease a flashing digit, or select a flashing digit for change.

Key operation

Simultaneous pressing of two keys:

In the case of key operation like + , press key while pressing key.

Two keys are pushed together at a time in 5 ways as shown in the right table. Press a key in column B while pressing a key in column A in such a case.

Operation	A	B
Reset (RESET)	PROG	<u>RUN</u> HOLD
Advance (ADV)	PROG	DISP
Programming start	FUNC	PROG
Program data erase	FUNC	CLR
Program copy	▲	PROG

Operation of specific keys

1. · · operation

⇒ Press key when you want to complete the set-up, parameter mode, or PID tuning.

- ① Select an operation mode by , , or key.
- ② Select each mode item by , , , , or key.
- ③ Specify by key, if you want to change data. Data flushes.
- ④ Change data by key.
- ⑤ Store data by key.

2. Key operation in programming mode

⇒ Press key when you want to complete the programming mode.

- ① Select program No. by key.
- ② Press + keys, and PRG (PROG) LED lamp lights.
- ③ Operate keys according to the lighting condition of PRG (PROG) lamp as follows.

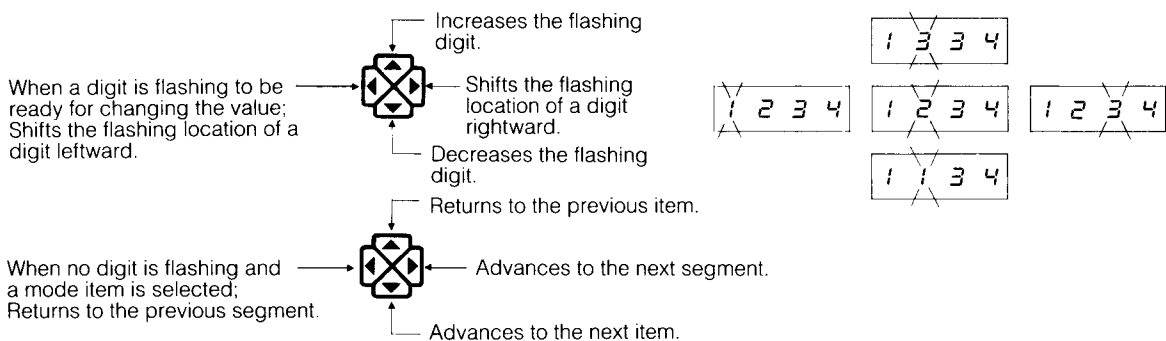

By pressing key when no digit is flashing, the digit will start to flash to be ready for changing the value.

By pressing key when a digit is flashing, the data can be stored in memory.

MODE TRANSITION DIAGRAM

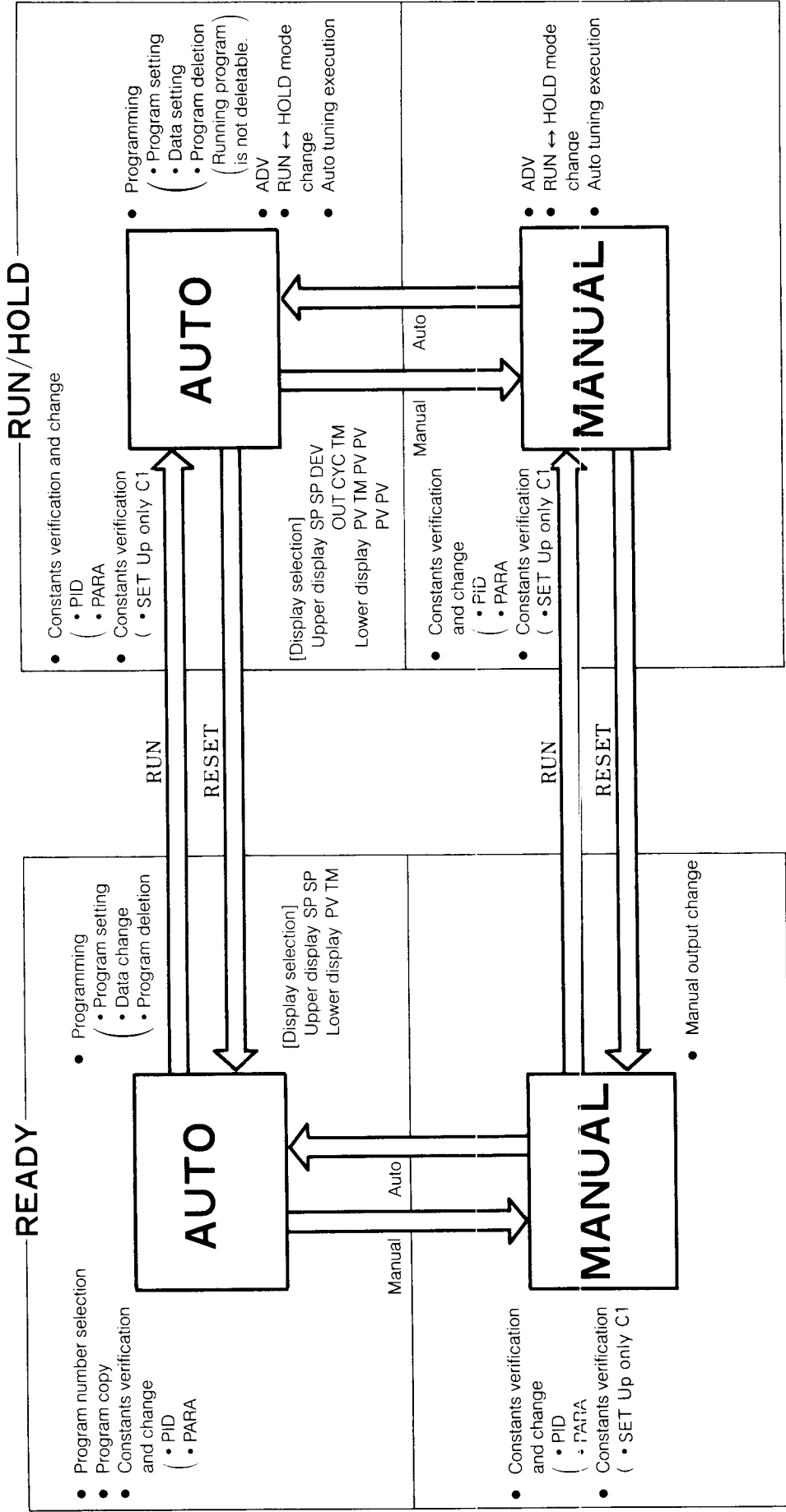

2. OUTLINE OF PROGRAMMING

Turn on the power supply



In case of the ready mode;



Perform setting operation based on each mode.



Reset the programmer first, if it is operating.



Resetting method

Press key while pressing .

Instruction pages of modes	Display at the start of mode	Setting example in a specified mode	Operation methods
Setup mode (Initialization) See page 18.	Press key. (SP)		<ul style="list-style-type: none"> Each code from C 1 to C 33 appears in a display when key is pressed sequentially. If C 1 is not displayed, press key and then, press key again.
Parameter mode (Constant value setting) See page 24.	Press key. (SP)		<ul style="list-style-type: none"> Each code from P r t c to H Y S Z appears in a display when key is pressed sequentially. If P r t c is not displayed, press key and then, press key again.
Programming mode (Program setting) See page 29. (Note) Set the program mode first.	Press key. SP TM PROG SEG PRG		<ul style="list-style-type: none"> Select the programming mode by pressing key while pressing key. PRG LED lights.
Tuning mode (PID constants setting) See page 36.	Press key. (SP)		<ul style="list-style-type: none"> Each code from P t to i o u t appears in a display when key is pressed sequentially. If P t is not displayed, press key and then, press key again.
Operation mode (Running operation) See page 38.	Press key. PROG SEG RUN HLD MAN PRG SP TM		<ul style="list-style-type: none"> Press key, and then press key.

3.

SETUP MODE

① General

The setup mode decides the specifications as a program controller. The upper display shows a setup code representing a setup item, while the lower display shows setup data. This mode is executed in ready (ready for run) mode.

If an initial value satisfies the required specifications, the setup data change is not necessary. Proceed to the parameter mode on page 24 in such a case.

(Note) Initial values in the display show those set before the delivery from the factory.

Display/ setting order	Codes	Setup item	Selection or setting range	Initial value in display	Description
1	┌ 1	Key lock	0: No keylock 1: Setup change is not allowable. 2: Data are not changeable. 3: DISP only is changeable.	0	No key lock
2	┌ 2	Temperature unit	0: °C (Centigrade) -1: °F (Fahrenheit)		Indicated in case of a thermocouple or resistance thermometer bulb input.
3	┌ 3	Control action	0: Reverse action 1: Direct action	0	Nct indicated, if the main output of the current output model is SP.
4	┌ 4	Setting of manipulated variable (MV) in case of PV overrange.	0: Not provided 1: Provided	0	If initial value 0 is changed to 1 in ┌ 4, ┌ 5 appears.
5	┌ 5	Manipulated variable (MV) in case of PV overrange.	0.0 to 100.0% (Time proportional model) -10.0 to +110.0% (Current output model)	0.0 (%)	
6	┌ 6	Type of PV range	0 to 12 (T/C) 20 to 34 (RTD) 40 to 45 (Linear)		
7	┌ 7	Linear PV decimal point position	0 to 3	0	Displayed for a linear input model.
8	┌ 8	Linear PV lower limit	-1999 to upper-limit U	0	
9	┌ 9	Linear PV upper limit	Lower limit 9999U	1000	
10	┌ 10	SP limit lower-limit	0% FS to upper limit of range	0	Different depending upon the type of PV range code.
11	┌ 11	SP limit upper-limit	Lower-limit to 100% FS of range	100	Different depending upon the type of PV range code.
12	┌ 12	SP main output 4mA setting	0: MV 1: SP	0	Displayed in case of a current output model MV: Control output SP: Set point output for controller
13	┌ 13	SP main output 4mA setting	-1999 to +9999U	0 (%FS)	Displayed when initial value 0 is changed to 1 in ┌ 12 in case of a current output model.
14	┌ 14	SP main output 20mA setting	-1999 to +9999U	100 (%FS)	
15	┌ 15	Type of auxiliary output	0: PV 1: SP	0	Displayed when an auxiliary output is provided PV: Process variable SP: Set point
16	┌ 16	Auxiliary output 4mA setting	-1999 to +9999U	0 (%FS)	
17	┌ 17	Auxiliary output 20mA setting	-1999 to +9999U	100 (%FS)	

Display/ setting order	Codes	Setup item	Selection or setting range	Initial value in display	Description
18	C18	EV1, 2 programming	0: Item is displayed at the programming. 1: Item is not displayed at the programming.	0	
19	C19	T1-T4 programming	0: Item is displayed at the programming. 1: Item is not displayed at the programming.	0	
20	C20	PID group, G.SOAK programming	0: Item is displayed at the programming. 1: Item is not displayed at the programming.	0	
21	C21	PV start, cycle programming	0: Item is displayed at the programming. 1: Item is not displayed at the programming.	0	
22	C22	Communication address	0 to 254	0	Displayed when the communication function is provided. Designates communication address when the communication function is provided.
23	C23	Transmission speed	0: 9600 1: 4800 2: 2400 3: 1200 (BPS)	0	
24	C24	Communication code	0: 8-bit even parity, 1 stop 1: 8-bit parity is not provided, 2 stop	0	
25	C25	Transmitting codes	0: Binary (for CMC300/400, MA500 DIM) 1: ASCII (for MX100 SCM)	0	See when communication function is provided
26	C26	PV	0: Displayed 1: Not displayed 2: Not displayed, but fixed to 0% of the range.	0	
27	C27	Time display	0: Residual segment time 1: Elapsed run time	0	
28	C28	Alarm display	0: Displayed 1: Not displayed	0	
29	C29	Program time unit	0: Hour, minute 1: Minute, second	0	
30	C30	Input/output type, option type	(Hexadecimal number)	--	Not rewritable. (*1) Initial value is E.4.0.0. in the display in case of K09 (0 to 1200°C), for example.
31	C31	Instrument code	135	135	Not rewritable.
32	C32	ROM ID	2049	2049	
33	C33	ROM version	—	—	

(*1) Table of combinations of initial values in the display for the item 30.

No. 1 digit	No. 2 digit	No. 3 to 4 digits
Model number optional function (1)		
0.: 000		
8.: 001	1.: Voltage output	0.0.: Thermocouple input
4.: 002		
C.: 003	2.: Relay output	0.1.: RTb input
6.: 004		
5.: 005	4.: Current output	0.2.: Linear input
E.: 006		
d.: 007		

Setup mode setting procedure



Refer to the key operation on page 18. For the setup contents, see page 15. Although there are setup items from No.1 to No.33, the setup setting procedures for the selected setup items will be described here.

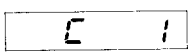
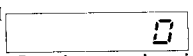

Press  key first.

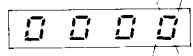

1 Key lock

SP  Initial setup display:
 TM  0: Indicates that no key lock function is provided.

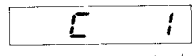
Set the number in the lower display to 2 when specifying the data to be unchangeable.

 The digit flashes when pressing  key.

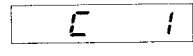



  Increase the number to 2 by pressing this key.

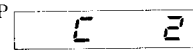
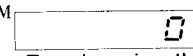

 Press  key.

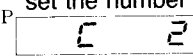

2 Temperature unit

SP  Temperature unit is initially set to °C (centigrade).
 TM  Initial setup display:
 0: Indicates centigrade (°C).

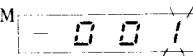

For changing the temperature unit to °F (Fahrenheit), set the number in the lower display to -1.

SP 
 TM  The digit flashes when pressing  key.



SP 
 TM   Increase the number to 1 by pressing this key.



SP 
 TM  Press  key.

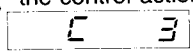

3 Control action

SP  Initial setup display:
 TM  0: Indicates the reverse control action.

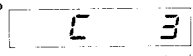
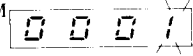
Set the number in the lower display to 1 for changing the control action to direct control action.

SP 
 TM  The digit flashes flickers when pressing  key.

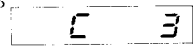

SP 
 TM   Increase the number to 1 by pressing this key.

SP 
 TM  Press  key.

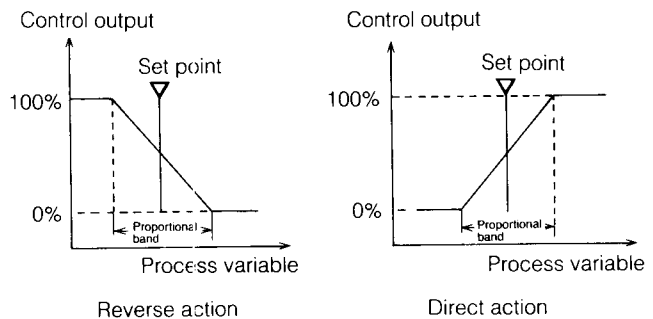
- This item selects either reverse action or direct action of the control output. The control output is initially set to the reverse action. Switch the control output by this item if the direct action is necessary.
- 0: Reverse action As process variable increases, the control output decreases. This action is generally used for heating control, etc.
- 1: Direct action As process variable increases, the control output increases. This action is generally used for cooling control, etc.



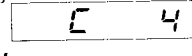

4 Setting of manipulated variable in case of PV overrange

SP  Initial setup display:
 TM  0: Not provided. Not designated.



Set the number of the lower display to 1 for changing to "Provided, Designated".

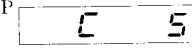

This item specifies the control output when an input exceeds the upper/lower-limit values of the range. This item is utilized for specifying the control output to safety when an input signal is interrupted.

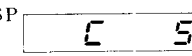
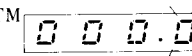

5 Manipulated variable in case of PV overrange

SP  Proceed to when 1 is selected at C 4.
 TM  Initial setup display:
 0 0: 0.0 to 100.0% (0D, 6D models)
 -10.0 to 110.0% (5G model)

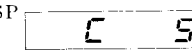
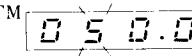
Set the value in the lower display to 50.0 for changing the setting range to 50.0.

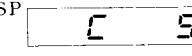

SP 
 TM  The digit flashes when pressing  key.

SP 
 TM   Shift the flashing location of a digit by pressing this key.



SP 
 TM   Increase the flashing digit to 5 by pressing this key.



Pressing  key.

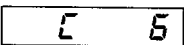

6 PV range type

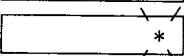
S P  Initial setup display:
 TM  *: Indicates No. corresponding to input type/range of model No.

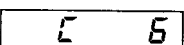
To change the input type/range from * to 10, set the lower display to 10.

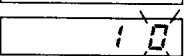
S P  Press  key. * flashes.
 TM 

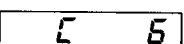
S P   Increase the number to 10
 TM  by pressing this key or this key.

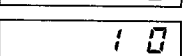
S P  Press  key.
 TM 

Note: With thermocouple types, only 0 to 12 can be selected. With RTD types, only 20 to 34 can be selected. With linear types, only 40 to 45 can be selected. On the Z13 model, other input types/ranges cannot be changed to.

7 Linear PV decimal point position

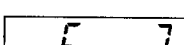
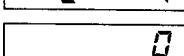
S P  Initial setup display:
 TM  0: Indicates that the decimal point is not used.

This item determines the decimal point position for the linear input (C01: 4 to 20mA dc, M01: 0 to 10mA dc, V01: 1 to 5V dc) range designation. Select a number from the following table for a suitable decimal point position.

Decimal point position	Initial value selection range
× × × ×	0
× × × . ×	1
× × . × ×	2
× . × × ×	3

For displaying a 4 to 20mA dc input as a 0 to 1000 range, the following setting is made.

Decimal point position	0
Lower-limit value	0
Upper-limit value	1000

If you want to set the unit to PPM, the unit can be set and indicated to 0 to 1000 PPM by labeling the attached industrial unit to the right of the upper- and lower-displays.

8 Linear PV lower-limit

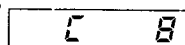
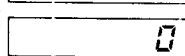

S P  Initial setup display:
 TM  0: -1999 to upper-limit U

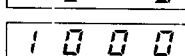

9 Linear PV upper-limit

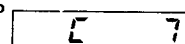

S P  Initial setup display:
 TM  1000: Lower-limit to 9999

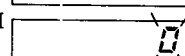
(Example)

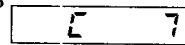
Perform the following operation for setting the linear input to 0 to 200.0. (Example of 7, 8, 9 items)

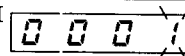
S P  The digit flashes when pressing  key.
 TM 

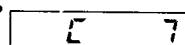
S P   Increase the number to 1
 TM  by pressing this key.

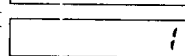

S P  Press  key.
 TM 

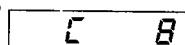
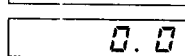

Press  key for proceeding to the lower limit item.

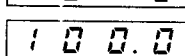

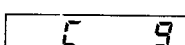
S P  The initial setup display: 0.0.
 TM 

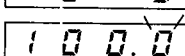
Press  key for proceeding to the lower limit item.

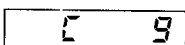
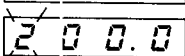
S P  The initial setup display shows 1000.
 TM  However, since the decimal point position is the 2nd from the right, it is indicated as 100.0.

S P  Press  key.
 TM 

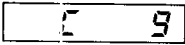
S P  Shift the flashing location of a digit by pressing this key.
 TM   Increase the flashing digit to 2 by pressing this key.

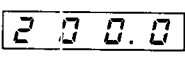
S P  Press  key.
 TM 

10 SP limit lower-limit

SP
 TM

The initial setup display shows 0% FS. This is the low end value of the range. (Depends upon range).

11 SP limit upper-limit

SP
 TM

The initial setup display shows 100% FS. This is the high end value of the range. (Depends upon range) (1200 in case of 0 to 1200°C range, for example).

- This item restricts the setting range of a program. If the temperature limit of an equipment is 600°C, for example, this item does not allow the equipment to be set to higher than 600°C, so that the equipment is protected or prevented from being set to be higher than the temperature limit, or, 800°C, for example, by mistake. The SP limit restricts the SP setting range in programming, and it is not effective for a preset SP, a running SP in which an SP bias is added, and a manual SP.

Since the digit of is 0, the lower-limit remains unchanged, but the upper-limit value is changed.

SP
 TM

By pressing the key, the digit flashes.

SP
 TM

Shift the flashing location of a digit by pressing this key.

Change the flashing digit to 6 by pressing these keys.

SP
 TM

Press key.

15 Type of auxiliary output

SP
 TM

Initial setup display:
 0: Specifies whether PV is set or not.
 1: Specifies whether SP is specified or not.

16 Auxiliary output 4 mA setting

SP
 TM

Initial setup display shows 0% FS. It differs according to the type of PV range code.

17 Auxiliary output 20 mA setting

SP
 TM

Initial setup display shows 100% FS. It differs according to the type of PV range code.

(Example) 15, 16, 17

When a PV value is an auxiliary output as 0 to 100 to a recorder.

SP
 TM

This digit remains unchanged. Proceed to the next item.

Press key for proceeding to the next item, "auxiliary output 4 mA setting".

SP
 TM

The digit flashes when pressing key.

SP
 TM

Shift the flashing location of a digit by pressing this key.

Change all digits to 0 by pressing these keys.

SP
 TM

Press key.

Press key for proceeding to the next item, "auxiliary output 20 mA setting".

SP
 TM

The digit flashes when pressing key.

SP
 TM

Shift the flashing location of a digit by pressing this key.

Change the value to 100 by pressing these keys.

SP
 TM

Press key.

Items 18 to 21 are used not to display unnecessary items so that the programming mode is free of items where setting is not changed usually.

Make unnecessary items not to be displayed by 18 to 21, because all items appear in initialization. (See the following table)

These items are not displayed, but the set points remain effective. Make sure again before setting these items that all set points are correct and their display is not necessary.

Segment item		1	2	3	...	20
SP time	Upper display	SP				
	Lower display	Time				
Event No. 1	Upper display	(Goes out)				
	Lower display	Event set point				
Event No. 2	Upper display	(Goes out)				
	Lower display	Event set point				
Time event No. 1	Upper display	ON time				
	Lower display	OFF time				
Time event No. 2	Upper display	ON time				
	Lower display	OFF time				
Time event No. 3	Upper display	ON time				
	Lower display	OFF time				
Time event No. 4	Upper display	ON time				
	Lower display	OFF time				
PID group selection	Upper display	-PId				
	Lower display	Group No.				
G.SOAK setting	Upper display	g.s				
	Lower display	no. SE5				
PV start setting	Upper display	-P.St.R				
	Lower display	no. SE5				
Cycle setting	Upper display	cycle				
	Lower display	Cycle				

18 EV1, 2 programming

SP

TM

Initial setup display:
0: Displays the item.
1: Does not display the item.

19 T1 to T4 programming

SP

TM

Initial setup display:
0: Displays the item.
1: Does not display the item.

20 PID group, G.SOAK programming

SP

TM

Initial setup display:
0: Displays the item.
1: Does not display the item.

21 PV start, cycle programming

SP

TM

Initial setup display:
0: Displays the item.
1: Does not display the item.

(Example) 18, 19, 20, 21

When the display of the time events T1 to T4 is not required;

SP

TM

The digit flashes when pressing key.

SP

TM

Change the number to 1 by pressing this key.

SP

TM

Press key.

The shaded portion consisting of the line of every programming item and the row of every segment (see the table on page 28) is not displayed.

26 PV

SP

TM

Initial setup display:

0: Input signal from thermocouple, resistance thermometer bulb, or linear input sensor is processed as PV.

1: The same PV input as described above is not displayed as PV on the console.

2: The value of the 0% FS of the range is processed as PV, irrespective of the input from sensor. A PV overrange alarm is not indicated.

27 Time display

SP

TM

A time (TM) to be displayed in the RUN or HOLD mode is selectable.

0: Displays the residual time of a running segment by rounding down the portion below the selected time unit.

1: Displays the lapsed time from the running start by rounding down the portion below the selected time unit.

28 Alarm display

SP

TM

Initial setup display:

0: Displays an alarm.

Displays alarms sequentially, if two or more alarms occur concurrently.

1: Does not indicate any alarm.

An alarm condition can be read by means of communication.

29 Program time unit

SP

TM

Initial setup display
0: Hour, minute
1: Minute, second

Specifies either hour/minute unit or minute/second unit to set the program pattern time (TM) and time even on-off.

4.

PARAMETER MODE

General

Parameters are provided to decide constants as the program controller. The parameter code indicating an item is displayed in the upper display, while a setting value is displayed in the lower display.

The setting in this parameter mode is not necessary, if an initial value satisfies the required specifications.

Proceed to the programming mode on page 27 in such a case.

Display/ setting order	Codes	Parameter item	Selection or setting range	Initial value in display	Description
1	<i>P r t c</i>	Program protect	0: Not provided 1: Provided	0	
2	<i>F i l t</i>	PV filter constant	0.0 to 120.0 sec	0.0	Not displayed when PV=0% fixed in SET UP [2 5.
3	<i>P b i A</i>	PV bias	-100 to +100U	0 (U)	
4	<i>S b i A</i>	SP bias	-50 to 50%FS	0 (U)	
5	<i>G.S.o a k b d</i>	G.SOAK band	0 to 100U	5 (U)	
6	<i>c y</i>	Time proportional Output cycle	5 to 120 sec (relay output model) 1 to 60 sec (voltage output model)	10	Displayed in 0D, 6D (time proportional) model, but not displayed in 5G (current output) model.
7	<i>o u t L</i>	MV change limit	0.0 to 100.0% (every 0.5 sec)	100.0	Not displayed, if main output of 5G (current output) is set (SP).
8	<i>d i f f</i>	ON/OFF control differential	0 to 100U	5 (U)	Displayed in 0D, 6D (time proportional) model, but not displayed in 5G (current output) model.
9	<i>E t 1</i>	Event 1 type	0: PV (direct action) 1: PV (reverse action) 2: Deviation (direct action) 3: Deviation (reverse action) 4: RUN 5: READY 6: END 7: PV lower limit (ON) 8: PV lower limit (OFF)	0	The relay turns to NO in PV direct action, and it turns to NC in PV reverse action. Turn "ON" at below PV lower limit Turn "OFF" at below PV lower limit
10	<i>H Y S 1</i>	Event 1 hysteresis	0 to 100U	5 (U)	specifies an on-off differential of event.
11	<i>E t 2</i>	Event 2 type	0: PV (direct action) 1: PV (reverse action) 2: Deviation (direct action) 3: Deviation (reverse action) 4: RUN 5: READY 6: END 7: PV lower limit (ON) 8: PV lower limit (OFF)	0	Turn "ON" at below PV lower limit Turn "OFF" at below PV lower limit
12	<i>H Y S 2</i>	Event 2 hysteresis	0 to 100U	5 (U)	specifies an on-off differential of event.
13	<i>r P I d</i>	PID algorithm AT advance	0: Not initialize 1: Initialize	0	

Parameter mode setting procedure

Refer to the key operation on page 15. For the parameter mode contents, see page 24.
This paragraph describes the operation procedure for the selected parameter items out of No.1 to 11.

Press PARA key first.

1 Program protect

SP P r t c
TM 0 Initial parameter display:
0: Does not protect any program.

Set the number in the lower display to 1 for protecting a program.

SP P r t c
TM 0 0 0 0 The digit flashes when pressing
ENT key.

SP P r t c
TM 1 ↕ Increase the number to 1
by pressing this key.

SP P r t c
TM 1 Press ENT key.

- (1) This item inhibits the reset of programmed data.
- (2) When selecting 1 "Protects a program" after programming, none of all program data can be reset until 0 "Does not protect any program" is selected.

2 PV filter constant

SP F I L T
TM 0 . 0 Initial parameter display:
0.0: 0.0 to 120.0 sec

PV filter effect:

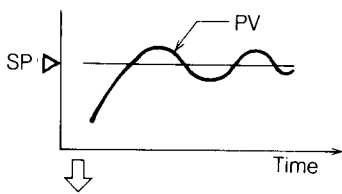

PV filter: Setting range
0.0 to 120.0 sec

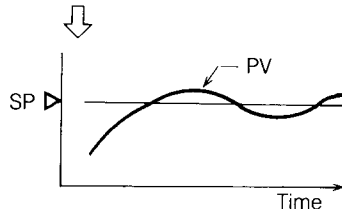

- (1) This item is used to set a PV filter constant.
- (2) The PV filter is used to filter the erratic input signal to the degree needed to get a stable. The filter effect increases as the numeric filter setting value increases.

3 PV bias

SP P b i A
TM 0 Initial parameter display:
0: -100 to 100U

PV bias effect:

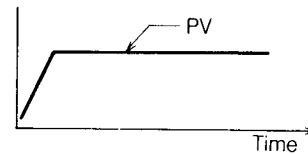

PV bias effect:

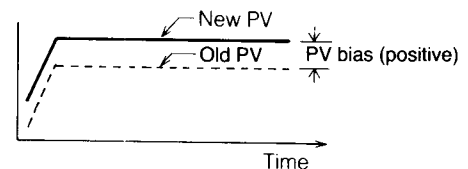

- (1) This item sets a PV bias value.
- (2) The PV bias is used to compensate for input such as the compensation of the drift of an input value due to deterioration of a sensor or other causes. A new PV value is obtained by adding a bias value.

5 G SOAK band

SP 3 . 5 . 6 d
TM 5 Initial parameter display:
5U: 0 to 100U

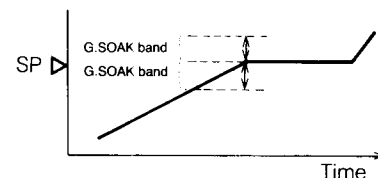

- (1) This item sets a G.SOAK band value.
- (2) G.SOAK shows the segment start point specified in programming, and the time is stopped until the absolute value of a deviation between PV and SP becomes smaller than the G.SOAK band.
- (3) G.SOAK is settable for every segment, irrespective of soaking, rising, or falling of segments.

6 Time proportional output cycle

SP

TM

Initial parameter display:
5 to 120 sec (Relay output, 0D model)
1 to 60 sec (Voltage output, 6D model)

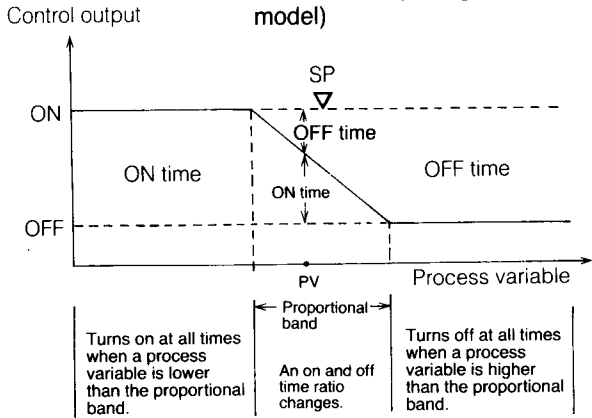

- (1) This item specifies the cycle time (control cycle) of the time proportional output.
- (2) If the cycle time (one cycle of on and off time) is set to 10 seconds, for example, the on time is 7 seconds when a process variable (PV) is lower than a set point (SP) in the proportional, and it becomes longer than off time (3 seconds).

7 Manipulated variable change limit

SP

TM

Initial parameter display:
100.0: 0.0 to 100.0% (every 0.5 sec)

This item specifies the limit of a change quantity of the former arithmetic value and present arithmetic value of the control output. This limit is determined by the following calculation formulas.

- A=Former arithmetic value (%)
- B=Present arithmetic value (%)
- C=Manipulated variable change limit (%)
- D=Actual output value (%)

(Example 1) Assume that A+20, B=50 and C=20.

$$B-A = 50 - 20 = 30$$

$$30 \geq 20 = C$$

thus, $D = 20 + 20 = 40$

$$D = A + C, \text{ if } |B-A| \geq C$$

(Example 2) Assume that A=20, B=50 and C=40.

$$B-A = 50 - 20 = 30$$

$$30 < 40 = C$$

thus, $D = 20 + 30 = 50$

$$D = B, \text{ if } |B-A| < C$$

- (1) This item controls a control output change quantity.
- (2) The output arithmetic value is updated once every output update cycle 0.5 sec (twice every second). If the manipulated variable change quantity limit is 0.5%, an output is changeable 60% per minute.

8 on/off control differential

SP

TM

Initial parameter display:
5U: 0 to 100U

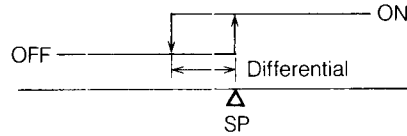

This item specifies the on/off control differential.

9 Event 1 type **10 Event 2 type**

SP

TM

SP

TM

Initial parameter 1

- 0: PV direct action
- 2: DEV (deviation) direct action

- 1: PV reverse action
- 3: DEV (deviation) reverse action

This item specifies whether an event is set to PV or DEV (deviation).

(Example) In case of PV event;

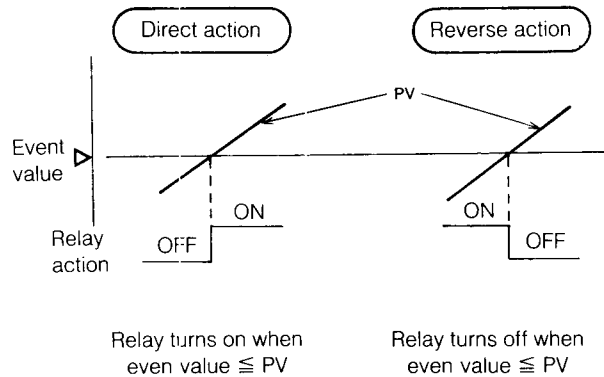

5.

PROGRAMMING MODE

Map type programming

- 1 Set the segments (patterns) on the abscissa first.
- 2 Set EV₁, EV₂, T₁ to T₄, PID, guaranteed soak, PV start, and cycle number on the ordinate.
- 3 Set the ordinate for every segment.
- 4 The  keys freely move on the map.
- 5 The present segment conditions (soaking, rising, falling) are indicated by LED lamps on the profile indicator.

Segment No. can be freely called by  multi-keys.

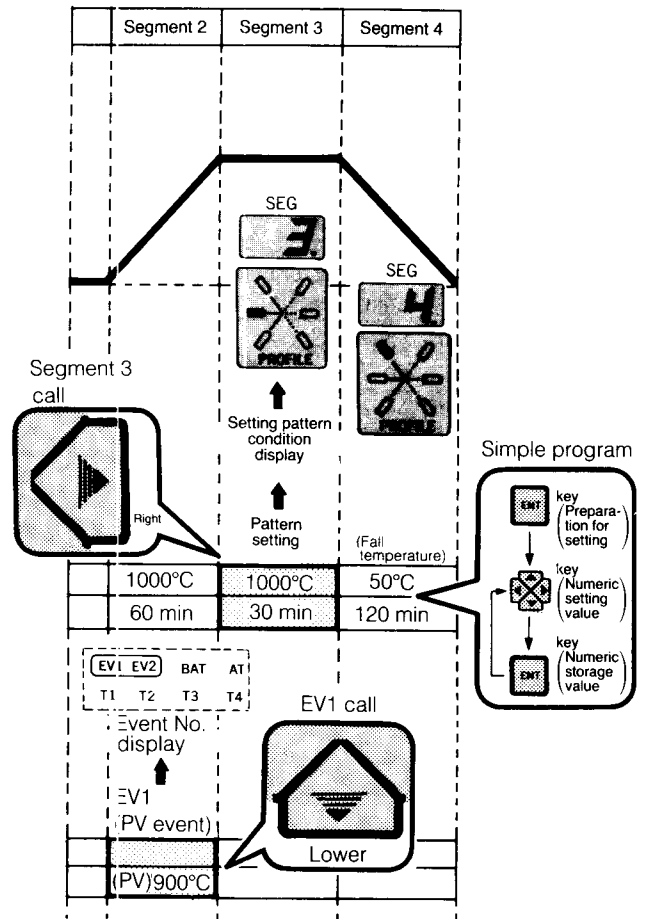

PROGRAMMING MAP

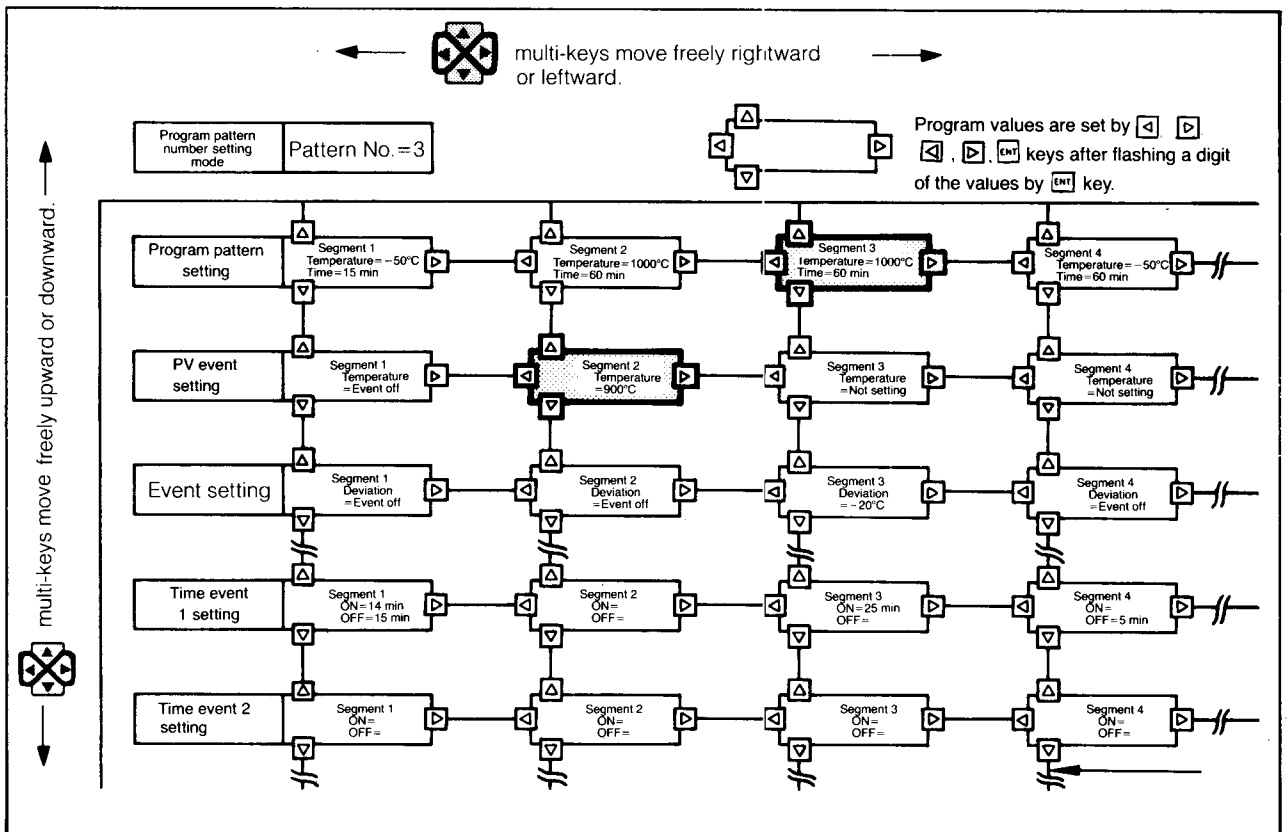





This table consists of lines of each programming item and row of each segment.

Map position	Item display position		Segment				Lighting lamp
			1	2	20	
A	SP and time	Upper display	SP *1	A1	A2		SP, TM
		Lower display	Time *1	A1	A2		
B	No. 1 event	Upper display	Event set point *1		B2 position		PV or DEV EV1
C	No. 2 event	Lower display	Event set point *1				PV or DEV EV2
D	No. 1 time event	Upper display	ON time *1				T1, TM
		Lower display	OFF time *1				
E	No. 2 time event	Upper display	ON time *1				T2, TM
		Lower display	OFF time *1				
F	No. 3 time event	Upper display	ON time *1				T3, TM
		Lower display	OFF time *1				
G	No. 4 time event	Upper display	ON time *1				T4, TM
		Lower display	OFF time *1				
H	PID group selection	Lower display	Group No.				"P I d"
I	G.SOAK setting	Lower display	no : Not set YES : Set				"G.S."
J	PV start setting	Lower display	no : Not set *2 YES : Set				"P.S t R"
K	Cycle setting	Lower display	Cycle number *2				"CYCL"

(Note) *1: "— — —" is displayed, if not set.

*2: One data only is settable for every program, and data are equal for every segment.

- The frame position is specified by combining the alphabetic characters (A to K) showing program map items with the numbers (1 to 20) showing segments. The frame of event No. 1 of segment 2 is represented as .

- Program setting, change, check, and other programming operations are executed by displaying the contents of each frame of the above programming map on the displays. The vertical move (items) and horizontal move (segments) of the frame of the programming map are executed by  multi-keys when displayed data are not flashing. If setting or change is not required, press  key once or twice to flash the aimed data and change data by  keys. Then, store the data by pressing  key.

* Since a blank programming map is attached to this manual at the last page, it is recommended to fill each item before starting the programming work for correct setting with a reduced setting time.

Program pattern

Map position	Segment item	1	2	3	20
A	SP						
	Time						
	Upper display						
	Lower display						

Main function (pattern data)

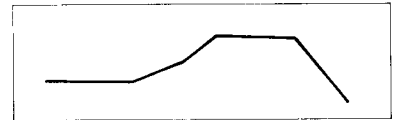

Subfunction (events and other data)

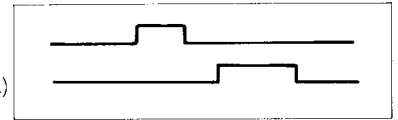

How to set a program pattern:

Set point

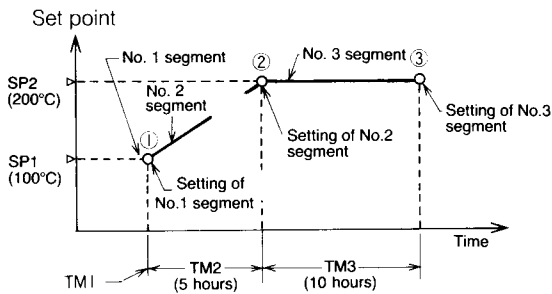

- (1) Set the basic program pattern.
 - (2) Prepare each segment (broken line) sequentially by assigning one point as shown in ①, ②, ③ in the left figure.
 - (3) Assign points ①, ②, ③ by combining SP (set points) and TM (time) switch each other.
 - (4) The unit of TM (time) is either hour/minute or minute/second, and it can be assigned by SET UP C29.
- Perform operation according to the assignment of C29 in the operation mode, irrespective of the assignment in the programming mode.

Segment No.	SP (Set point)	TM (time)	Description
1	100°C	0 hour	Start point designation. Soaking for 0 hour at 100°C
2	200°C	5 hours	Ramp segment designation. Heating for 5 hours up to 200°C
3	200°C	10 hours	Soaking segment designation. Soaking for 10 hours at 200°C

For setting the soaking segment, set the SP (set point) of the present point to the SP of the next point.

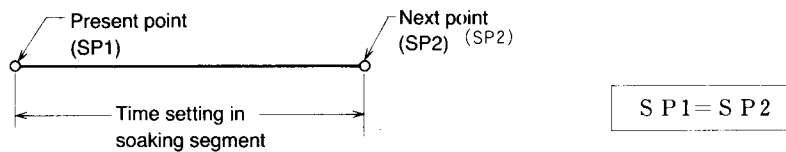

For setting the ramp, make a differential between the SP (set point) at the present point and the SP at the next point.

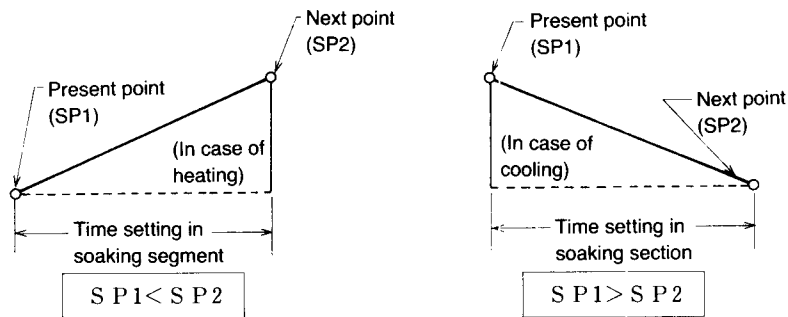

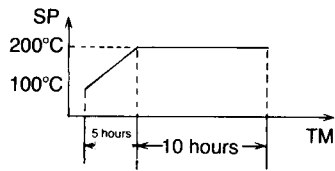



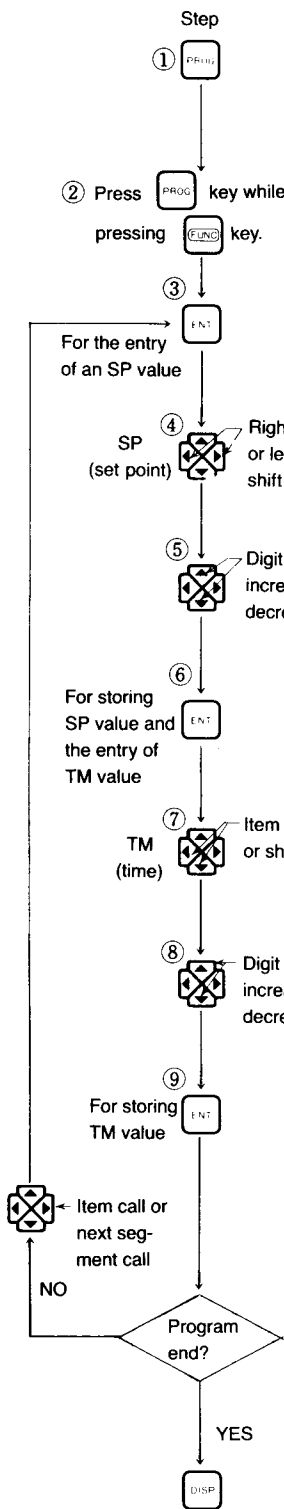



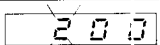
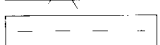

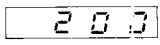
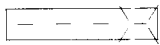

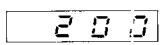
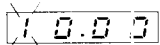

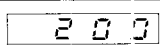
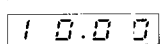
SP	Input range. Limit range when SP limit is set.
TM	0 to 99 hours 59 minutes

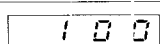
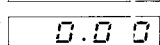

Map position	Key operation	Display	Description of display	Display of profile
A 1	Press PROG key.	PROG SEG 	Specifies program No. SP, TM, LED light.	
A 1	Press PROG key while pressing FUNC key.	SP --- TM ---	Sets to programming mode. PRG LED lights. PROG SEG decimal points light.	
A 1	Press ENT key.	SP --- TM ---	Segment 1 The last digit in SP display flashes. SP (set point) entry operation	
A 1	Press this key.	SP --- TM ---	Press this shift key (left), or continue pressing this shift key.	
A 1	Press this key.	SP 0100 TM ---	Increase the flashing digit by a digit increase key. Set SP=100(°C).	
A 1	Press ENT key.	SP 100 TM ---	The last digit in TM display flashes. TM entry operation	
A 1	Press this key.	SP 100 TM 00.00	Under this condition because TM=0 (hour)	
A 1	Press ENT key.	SP 100 TM 0.00	SP=100°C/TM=0 (hour) stored.	
A 2	Press this key.	SP --- TM ---	Segment 2 PROG SEG 1. 2.	
A 2	Press ENT key.	SP --- TM ---	SP entry operation	
A 2	Repeat (4) to (5) steps	SP 0200 TM ---	Set SP=200(°C).	
A 2	Press ENT key.	SP 200 TM ---	The last digit in TM display flashes. TM entry operation	
A 2	Repeat (7) to (8) steps	SP 200 TM 05.00	Set TM=5 (time).	
A 2	Press ENT key.	SP 200 TM 5.00	SP=200(°C)/TM=5 (hours) stored.	
A 3	Press this key.	SP --- TM ---	Segment 3 PROG SEG 1. 3.	
A 3	Press ENT key.	SP --- TM ---	SP entry operation	

Map position	Key operation	Display	Description of display	Display of profile
A 3	Repeat ④ to ⑤ steps	SP  TM 	Set SP=200(°C).	
A 3	Press  key.	SP  TM 	The first digit in TM display  .	
A 3	Repeat ⑦ to ⑧ steps	SP  TM 	Set TM=10 (hours).	
A 3	Press  key.	SP  TM 	SP=200°C/TM=10 (hours) stored.	
—	Press  key.	SP  TM 	Programming mode ends.	

Press  key during the flashing of SP or TM data. If the  key is pressed while pressing  key instead of setting data, all program data after the segment is deleted. Therefore, if this operation is done at the first segment, the entire program data are deleted.

Complete the program work sheet.

Map position	Segment	1	2	3	...	20
A	S P . T M					
B	E V 1					
C	E V 2					
L	Cycle setting					

Map position	Segment	1	2	3	...	20
B	EV1 event No.1					
C	EV2 event No.2					

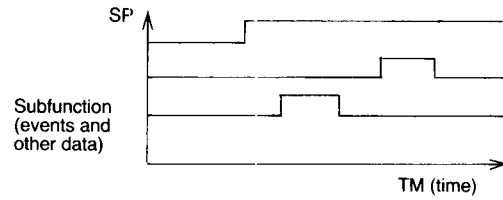
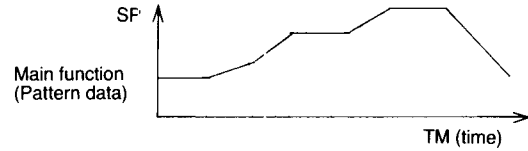

Finish the setting of the parameter mode items $\boxed{9}$ $\boxed{E E 1}$ and $\boxed{10}$ $\boxed{E E 2}$ first.

1. PV-based event circuit setting:

The PV-based event circuit is operated by comparing a PV and an event set point with each other.

Type of event	Relay action
PV (direct) (Off in ready mode)	
PV (reverse) (On in ready mode)	

2. DEV-based event circuit setting:

The DEV-based event circuit is operated by comparing a deviation (PV-SP) and an event set point with each other.

Type of event	Relay action
DEV (direct) (Off in ready mode)	
DEV (reverse) (On in ready mode)	

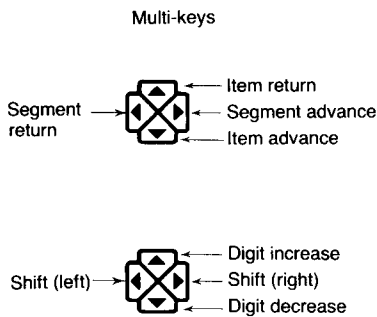

Setting range	
PV event	Input range
DEV event	0 to 50% FS of input range

Map position	Keying operation	Display	Description
B 3	<ol style="list-style-type: none"> Press item advance key. Press segment advance key. 		Shift's to B3 position ①PRG, EV1, and PV of display light. ②D splay segment (map B3) for event setting.
B 3	Press \boxed{ENT} key.		The first digit in a lower-display flashes.
B 3	<ol style="list-style-type: none"> Press shift key. Press digit increase key. 		Enter 100(°C).
B 3	Press \boxed{ENT} key.		Store PV event 100°C.

(Note) Setting is deleted by pressing \boxed{CLR} key while pressing \boxed{CLR} key instead of \boxed{ENT} key.

3. Time-based event circuit setting:

Map position	Segment	1	2	3	...	20
D	T1 time event					
E	T2 time event					
F	T3 time event					
G	T4 time event					

Time-based event circuit turns on and off with the program time, irrespective of the control output. They are specified by the time from the start point of the set segment.

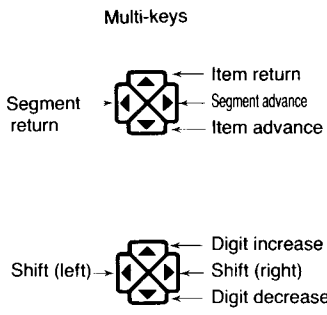
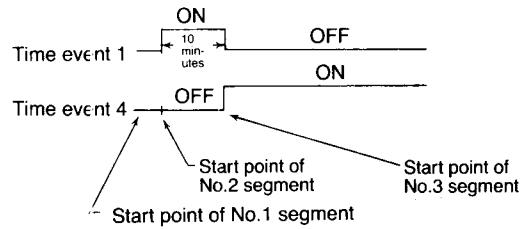
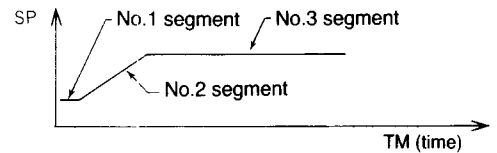

Map position	Key operation	Display	Description
D 2	① Press item advance key. ② Press segment advance key.	SP: [---] TM: [---]	Shift to D2 position ① RPG and T1 light. ② Display segment (map D2) for event setting.
D 2	Press [ENT] key.	SP: [---] TM: [---]	Press [ENT] key the first digit in upper display flashes for ON time setting.
D 2	Press [1] key.	SP: [0.0.0] TM: [---]	Set the time to turn on (0:00 in this case).
D 2	Press [ENT] key. (Note)	SP: [0.0.0] TM: [---]	Press [ENT] key the first digit in a lower display flashes for OFF time setting.
D 2	① Press the shift key (left). ② Press the numeric value increase key.	SP: [0.0.0] TM: [1.0.0]	Set the time to turn off (10:00 in this case).
D 2	Press [ENT] key. (Note)	SP: [0.0.0] TM: [1.0.0]	Time event 1 setting { ON: 0:00 OFF: 10:00

(Note) Setting is cancelled by pressing [C] key while pressing [ENT] key instead of pressing [ENT] key.

Setting item	Contents
Upper display	ON time
Lower display	OFF time

Setting range	
ON time	0:00 to 99:59
OFF time	0:00 to 99:59

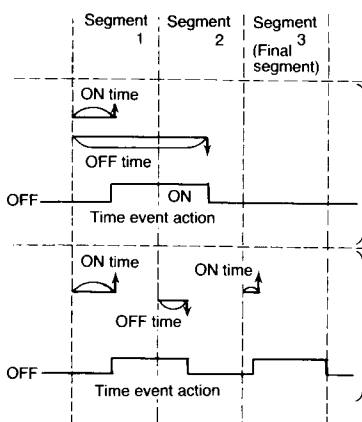

Example 1 In example 1, ON time and OFF time are set as one set at segment 1. Time event setting for a time exceeding the time of one segment is also possible.

Example 2 In example 2, the ON time only is set at segments 1 and 3, while the OFF time only is set at segment 2. ON and OFF can be set without combining ON and OFF time as one set. The time-based event circuit is turned off when the program ends.

4. PID group selection

Map position	Segment	1	2	3	20
H	PID group selection				

PID group No. to be employed in a segment is specified out of PID1, PID2, and PID3.

Set point	Contents
1	PID 1 group is used.
2	PID 2 group is used.
3	PID 3 group is used.

Multi-keys

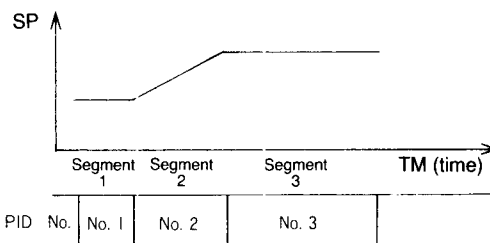
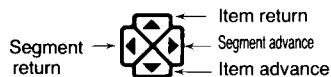

Map position	Key operation	Display	Description
H 2	① Press item advance key. ② Press segment advance key.	P i d 1	Shifts to H2 position. ① P i d . 1 is displayed in the upper display. ② Display the segment (map H2) for PID setting.
H 2	Press ENT key.	P i d 0 0 0 1	1 flickers in the lower display.
H 2	① Press digit increase key.	P i d 0 0 0 2	Increase the flashing digit to 2.
H 2	Press ENT key.	P i d 2	Store PID group No.2.

Note: PID values of each group are set by either PID tuning mode or AT action.

5. G.S (guaranteed soak) setting

Map position	Segment	1	2	3	20
I	G.S setting				

Specify this item for setting G.SOAK (guaranteed soak).

Setting item	Contents
YES	G.SOAK is set.
no	G.SOAK is not set.

Multi-keys

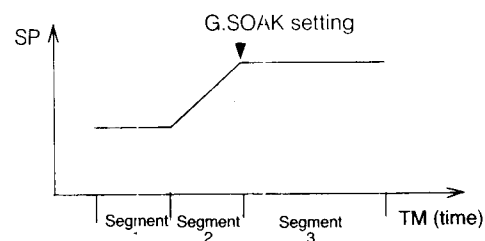
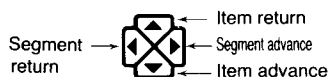

Map position	Key operation	Display	Description
I 3	① Press item advance key. ② Press segment advance key.	9 . 5 . no	Shifts to I3 position. ① LED lights. ② Display the segment (map I3) for G.SOAK setting.
I 3	Press ENT key.	9 . 5 . no	Press ENT key. no flashes.
I 3	① Press item return key.	9 . 5 . YES	YES flashes.
I 3	Press ENT key.	9 . 5 . YES	YES is set.

6. PV start setting

Map position	Segment	1	2	3	20
J	PV start setting				

Specify this item for starting the program from the present PV.

Setting item	Contents
YES	PV start is executed.
NO	PV start is not executed.

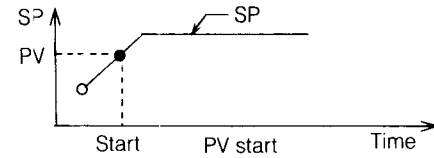
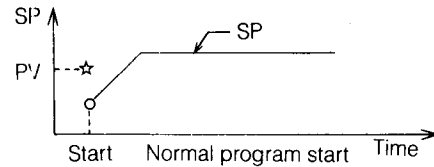

Multi-keys (nominal)

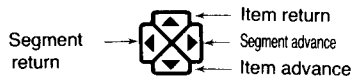

Map position	Keying operation	Display	Contents
J 1	① Press item advance key.	P.S t A n o	Data are displayed in the upper display. (Note) YES or NO of PV start can be set at any optional segment.
J 1	Press key.	P.S t A n o	NO flashes.
J 1	① Press item return key.	P.S t A Y E S	YES flashes.
J 1	Press key.	P.S t A Y E S	YES is set.

7. Cycle setting

Map position	Segment	1	2	3	20
K	Cycle setting				

Specify this item for executing the same program repeatedly.

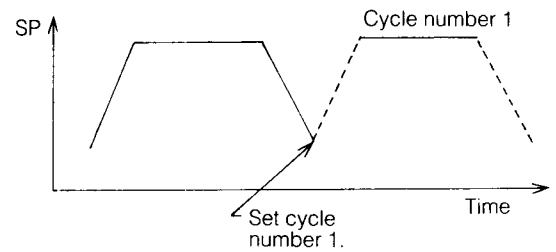

Multi-keys (nominal)

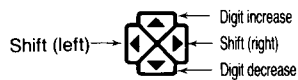

Map position	Key operation	Display	Description
K 3	① Press item advance key. ② Press segment advance key.	C Y C L 0	Shifts to K3 position. ① CYCL 0 is displayed in the upper display. ② Cycle number can be set in any optional segment.
K 3	Press key.	C Y C L 0	Press ENT key, 0 flashes.
K 3	① Press the digit increase key.	C Y C L 1	Assume that the cycle number is 1, set the digit to 1. 1 flashes.
K 3	Press key.	C Y C L 1	Cycle number 1 is set.

6.

PID TUNING

General

Specify and set P (proportional band), I (integral time), D (derivative time), and the upper-limit and lower-limit of manipulated variables.

Tuning is done by either manual tuning or auto tuning.

- Manual tuning (PID constants are set manually.)
- Auto tuning (PID constants are automatically set.)

Display/ setting order	Code	Tuning item	Selection or setting range	Initial value in display	Description
1	<i>AT</i>	Auto tuning selection	0: AT is not executed 1: Method 1 is executed by AT key. 2: Method 2 is executed by AT key.	0	Displayed only when auto tuning is provided. (Note) For methods, 1 and 2, see page 37.
2	<i>P - 1</i>	Proportional band 1	0.0 to 999.9% (time propor- tional) type 0.1 to 999.9% (current out- put) type	100.0	
3	<i>I - 1</i>	Integral time 1	0 to 3600 sec	0	Displayed when P≠0.
4	<i>d - 1</i>	Derivative time 1	0 to 1200 sec	0	Displayed when P≠0.
5	<i>oL - 1</i>	MV lower-limit 1	0.0 to upper-limit % (time proportional) type -10.0 to upper-limit % (cur- rent output) type	0.0 -10.0	Displayed when P≠0.
6	<i>oH - 1</i>	MV upper-limit 1	Lower-limit to 100.0% (time proportional) type Lower-limit to 110.0% (current output) type	100.0 110.0	Displayed when P≠0.
7	<i>rE - 1</i>	Manual reset 1	0.0 to 100.0%	50.0	Displayed when P≠0 and I=0.
8	<i>P - 2</i>	Proportional band 2	0.0 to 999.9% (time proportional) type 0.1 to 999.9% (current output) type	100.0	
9	<i>I - 2</i>	Integral time 2	0 to 3600 sec	0	Displayed when P≠0.
10	<i>d - 2</i>	Derivative time 2	0 to 1200 sec	0	Displayed when P≠0.
11	<i>oL - 2</i>	MV lower-limit 2	0.0 to upper-limit % (time proportional) type -10.0 to upper-limit % (cur- rent output) type	0.0 -10.0	Displayed when P≠0.
12	<i>oH - 2</i>	MV upper-limit 2	Lower-limit to 100.0% (time proportional) type Lower-limit to 110.0% (cur- rent output) type	100.0 110.0	Displayed when P≠0.
13	<i>rE - 2</i>	Manual reset 2	0.0 to 100.0%	50.0	Displayed when P≠0 and I=0.
14	<i>P - 3</i>	Proportional band 3	0.0 to 999.9% (time propor- tional) type 0.1 to 999.9% (current out- put) type	100.0	
15	<i>I - 3</i>	Integral time 3	0 to 3600 sec	0	Displayed when P≠0.
16	<i>d - 3</i>	Derivative time 3	0 to 1200 sec	0	Displayed when P≠0.
17	<i>oL - 3</i>	MV lower-limit 3	0.0 to upper-limit % (time proportional) type -10.0 to upper-limit % (cur- rent output) type	0.0 -10.0	Displayed when P≠0.
18	<i>oH - 3</i>	MV upper-limit 3	Lower-limit to 100.0% (time proportional) type Lower-limit to 110.0% (cur- rent output) type	100.0 110.0	Displayed when P≠0.
19	<i>rE - 3</i>	Manual reset 3	0.0 to 100.0%	50.0	Displayed when P≠0 and I=0.
20	<i>I o u t</i>	PID operation Initial MV	0.0 to 100.0%	0.0	Displayed, if at least one P=0 out of 1 to 3 groups.

PID tuning procedure

Refer to the key operation note on page 15.

For the contents of PID tuning mode, see page 36.

This paragraph describes the operating procedures for the selected PID tuning items out of No. 1 to 20.

Press PID key.

1 Auto tuning selection

SP A t
 TM 1

Initial tuning display:
 0: AT is not executed.
 1: Method 1 is executed by AT key.
 2: Method 2 is executed by AT key.

Auto tuning method 1 or 2 is described below.

1: Method 1

The most popular control constants can be set automatically. Overshoot may more or less occur. This method is used when the arrival time to a set point is regarded as important.

2: Method 2

This method is used when noticeable overshoot is presumable on an equipment or when it is desired to suppress overshoot. In many cases, the overshoot is restricted. However, rising is apt to be delayed.

I and D: Unlike in on/off action, the P control action does not easily produce any undulation phenomenon. However, it is possible that the temperature remains deviated from a set point.

I and D control action are provided for preventing such a failure. In electric furnaces, I is generally set to 150 sec, while D is generally set to about 30 sec. As I becomes shorter, or as D becomes longer, the control function becomes stronger. However, the control function is too strong to ensure the control to be executed satisfactorily at all times.

Both I and D are off at 0.

(Examples)

In case of 10% proportional band in 0° to 800°C range, P is 80°C.

If I is short (strong), the control may often become excessive.

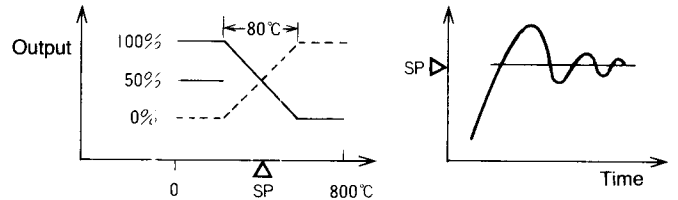

2 Proportional band 1

SP P - 1
 TM 1 0 0 . 0

Initial tuning display

3 Integral time 1

SP 1 - 1
 TM 0

Initial tuning display

4 Derivative time 2

SP d - 1
 TM 0

Initial tuning display

Setting range:

$P-1, P-2, P-3$: $\begin{cases} 0.0 \text{ to } 999.9\% \text{ (time proportional type)} \\ 0.1 \text{ to } 999.9\% \text{ (current output type)} \end{cases}$

$I-1, I-2, I-3$: 0 to 3600 sec

$D-1, D-2, D-3$: 0 to 1200 sec

P: This constant determines the deviation ratio of a PV to a set point of a temperature, where the control output is to be set to 0 or 100. This value is set by %, and an about 10% is generally used for electric furnaces.

As this range becomes narrower, the sensitivity becomes higher. But, if the range is extremely narrow, an undulation phenomenon occurs.

5 MV lower-limit 1

SP o L - 1
 TM 0 . 0

Initial tuning display

6 MV upper-limit 1

SP o H - 1
 TM 1 0 0 . 0

Initial tuning display

Setting range

$oL-1, oL-2, oL-3$: 0.0 to upper-limit %
 (Time proportional type)
 -10.0 to upper-limit %
 (Current output type)



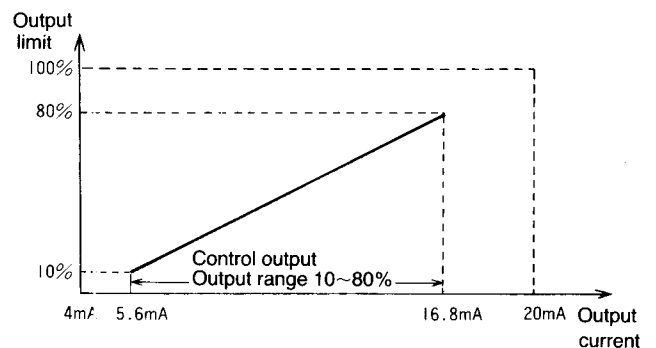



$oH-1, oH-2, oH-3$: Lower-limit to 100.0%
 (Time proportional type)
 Lower-limit to 110.0%
 (Current output type)



Check and set the following items before starting the program.

1. Is PV start executed?
See page 19, 35.
2. Is auto tuning executed?
See page 36, 37.
3. Are PID constants set? Is the output limiter set?
See page 34, 36.
4. Is PV bias used?
See page 24, 25.
5. Is SP bias used?
See page 24.
6. Is PV filter used?
See page 24, 25.
7. Is the MV change quantity limit set?
See page 24, 26.
8. Is the program protect function provided?
See page 24, 25.

Key operation

-  : Specifies the program number.
-  : Change the mode from ready to RUN or from RUN to HOLD.
-  : Specifies the display contents of the upper-display and lower-display.
- * For resetting to the ready mode (from RUN or HOLD), press  key while pressing  key.
- * For advancing the segment by one under RUN/HOLD mode, press  key while pressing  key.

Monitoring during program run

1. The program number and segment number display contents are as shown below during run and programming check.

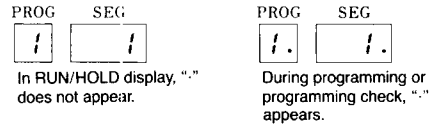

2. When  key is pressed, the upper- and lower-display indicator lamps indicate the contents of both upper- and lower-display by their combinations. The upper- and lower-display indication lamps are combined with each other as follows.

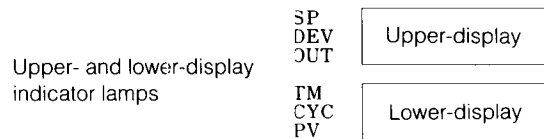

Combinations of upper- and lower-display indicator lamps

Upper-display	SP	DEV	OUT	TM	CYC	SP
Lower-display	PV	PV	PV	PV	PV	TM

3. Mode indication by mode indicator LED lamps

RUN: Lights during run.
HLD: Lights during hold.
MAN: Lights in manual operation mode.
PRG: Lights in programming mode.
(Note) None of mode indicator lamps lights under the ready mode.

4. Running pattern conditions, easily monitorable by profile indicator LED lamps

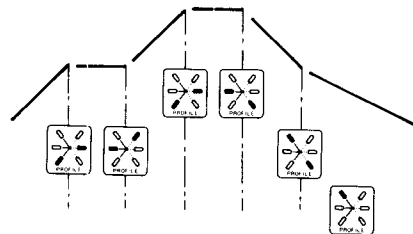

Program status display:

- Indicates rising, soaking, and falling tendencies of program pattern.
 - Indicates the present segment and next segment.
5. For identifying pattern which has already set or not, check if the upper-display shows the following contents when a program number is entered by  key.

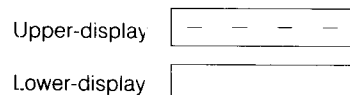

OPERATION EXAMPLES

1 Starting program

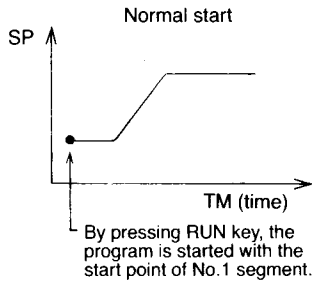

Specify the PV start no in programming. See page 35.
 When PV start is set to no in programming, the normal start is done.
 When PV start is set to YES in programming, the PV start is done.

Display	Key operation	Description of contents
	Press key.	Specify a program No. Press this key by necessary times.
	Press key.	Runs. •RUN LED lights. •PROFILE LED lights.

2 Starting a program from a preset temperature

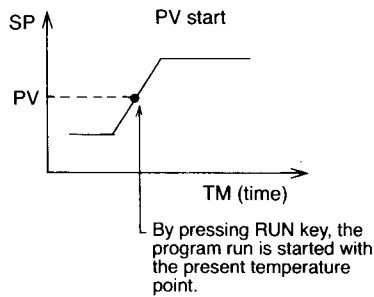

Specify PV start YES in programming. See page 35.

Display	Key operation	Description of contents
	Press key.	Specify a program No. Press this key by necessary times.
	Press key.	Runs. •RUN LED lights.

3 Holding a program

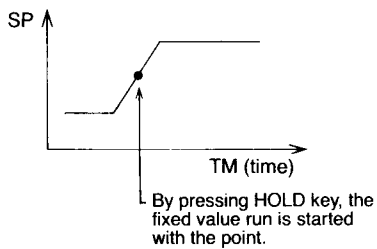

Display	Key operation	Description of contents
	Press key.	Holds. •HOLD LED lights.

4 Advancing a program to a new segment

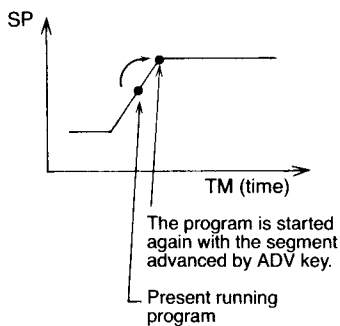

Display	Key operation	Description of contents
		Running.
	Press key while pressing key.	Perform ADV operation. The program proceeds to the start point of the next segment.

5 Starting auto tuning

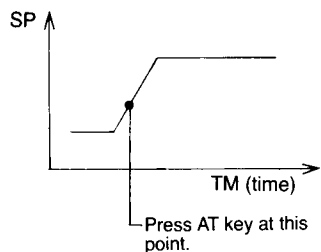

Display	Key operation	Description of contents
		During RUN or HOLD.
	Press key.	Auto tuning is started. •AT LED lights.
		Auto tuning ends automatically.

Description of auto tuning (AT) (option)

• Auto tuning is executed only when all the following conditions are satisfied.

- ① RUN or HOLD mode
- ② AUTO mode
- ③ PID constant is set to "1" or "2".
- ④ PV is within the range.

• When auto tuning ends, the PID group constants used for the segment are replaced with new constants by auto tuning.

• For stopping this auto tuning, press key during auto tuning. The auto tuning stops, and PID constants are not rewritten.

Auto tuning method:

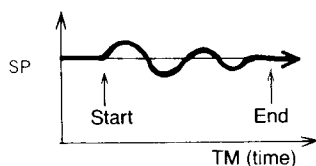

The on-off operation is repeated twice at about the set point of a temperature, and PID values newly calculated are used.

Whether the first control action is on or off depends upon the condition of PV and SP at that time.

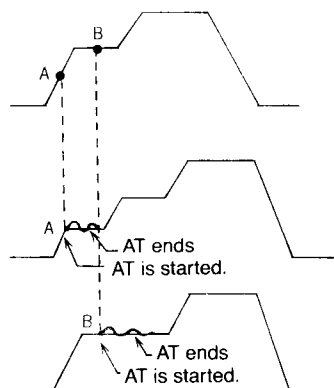

Auto tuning at point A

Be careful because a stepwise pattern appears halfway in the course of ramp.

Auto tuning at point B

The program automatically stops advancing temporarily when executing auto tuning. It is automatically restarted after the end of auto tuning.

6 Selecting manual control for the process

Display	Key operation	Description of contents
	Press key.	Upper-display for main output (MV or SP). Lower-display for PV.
	Press key.	MV or SP change Set an output value by multi-keys. The value is effective, even if key is not pressed.

Press key when returning to the automatic operation mode.

7 Stopping a program

Display	Key operation	Description of contents
		Running
	Press key while pressing key.	Program is reset to the ready mode. •RUN and HLD LEDs are off.

8 Copying stored program data under a different program number

Display	Key operation	Description of contents
	Press key.	Select a program number of the copy source by PROG key in an AUTO mode.
	Press key while pressing this key.	COPY is indicated on the upper-display, and --- is indicated on the lower-display. No display appears, if the copy source is not available.
	Press this key.	Select a program number in the lower-display program number is not displayed if some program is set already for the number.
	Press key.	Press ENT key to copy the program. However, it is not copied, if the total number of preset events of the instrument exceeds 200, the lower-display indicates --- .
	Press key.	Returns to the ready mode.

9 Changing program data

Select the mode to be corrected.





- Setup mode ———
- Parameter mode: ———
- PID tuning mode: ———
- Programming mode ——— +



Select an item to be corrected by keys, and press key.

Change program data by keys, and press key.

10 Storing the setting range limits of a program





$C10$: Lower-limit value
 $C11$: Upper-limit value

Setup mode.   or  keys, and press  key.



Change the program data by  keys, and press  key.

11 Deleting stored data

Set the ready mode.



 +  in RUN/HOLD mode.
 in MANUAL mode.
 in other cases.

Select the program No. of the program to be deleted by  key.

Select the programming mode by pressing  key while pressing  key.

Display the values of SP (set point) and TM (time) of segment 1 by  keys.

Start changing the values of SP or TM by  key to flash the value.

The program can be deleted by pressing  key while pressing  key.

12 Alarm code display

If a PV alarm or an instrument alarm is detected, a program segment No and its alarm code are displayed on the PROG/SEG indicator alternately every second, but the instrument run and other action are continued. However, if A90 alarm occurs, its alarm code only is continuously displayed on the PROG/SEG indicator, and the lower-stage indicator displays the present board input/output and option type. The instrument does not start any action.

Alarm code	Meanings	Remedial measures
$A 01$	PV is not within a range of -10 to $+110\%$ FS	Check the sensor/disconnection.
$A 90$	PC board is not properly mounted. (Check it only when power is turned on.)	Ask for repair.
$A 92$	EEPROM is defective.	Ask for repair.
$A 94$	SETUP and PARA parameter contents were broken.	Reset.
$A 95$	PID parameter contents were broken.	
$A 96$	Program pattern contents were broken.	
$A 98$	RAM is defective.	Ask for repair.
$A 99$	ROM is defective.	

13 Condition (of the DCP200) after recovery from a power failure

- A power failure to the DCP200 will occur when its power supply drops below 70V AC and remains below this level for longer than 100 msec.
- After sufficient power has been generated, all functions of the instrument will return to conditions existing before the failure, i.e. the display mode will continue operations from the point immediately before the failure. Operating time will also progress from the point immediately before the failure. However, the LED display and the EVENT operation will only reappear two to three seconds after sufficient power has been generated; upon reactivation, their timing will not coincide with the other operations' timing.

8.

REMOTE OPERATION

1. Remote operation

RUN, HOLD, RESET, ADV, AT, and other operations can be done by using external contacts. An automatic operation of the DCP200 can be made automatically by combining this remote operation function with a sequencer.

Remote operation terminals

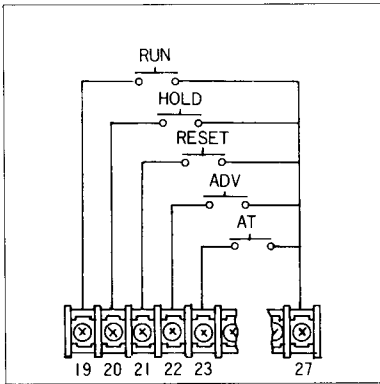

Program No. selection terminals

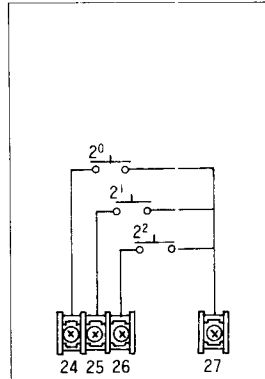

Program No.	Terminal connection
1	②7-②4
2	②7-②5
3	②7-②4, ②7-②5
4	②7-②6
5	②7-②4, ②7-②6
6	②7-②5, ②7-②6
7	②7-②4, ②7-②5, ②7-②6

(Example) Starting program No. 1

- Operation
1. Program No. 1 selection ———— ②7 and ②4
 2. Program start ————— ②7 and ②5
- Terminal connection

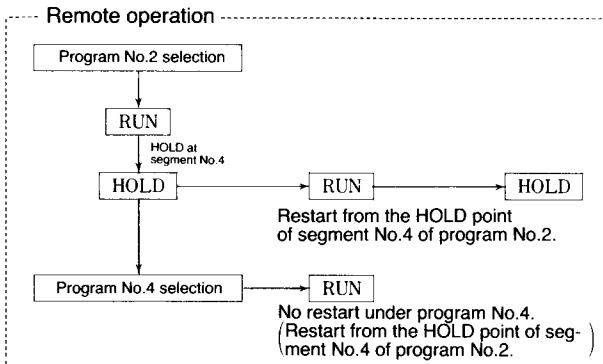
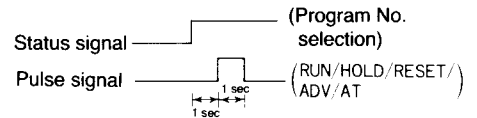

- The remote run start sequence is as follows:
Turn off RUN, HOLD, RESET, ADV and AT switches, and set three program No. setting switches. After one second or longer, continue turning on the RUN switch for longer than 1 second.

2. Description of remote operation

The remote input is acceptable when any one of RUN, HOLD, RESET, ADV and AT switches is turned on continuously for longer than 1 second after three switches of program No. were continued to be held for longer than 1 second with RUN, HOLD, RESET, ADV, and AT switches turned off. Setting of SETUP key lock does not affect any remote operation.

1) Remote operation

If a program specified by three program No. switches is already programmed when none of setting operations (programming, PID, PARA, SETUP) is done in the ready mode, the program is started running.

The program runs continuously from the HOLD point in the HOLD mode, irrespective of whether setting operations are executed or not. (The program number of the program to be run remains unchanged even if the specified program number differs from the running program number.)

2) Remote HOLD operation

The program is set to HOLD mode during run, irrespective of whether setting operation is done or not.

3) Remote RESET operation

The program is set to READY mode (waiting for run) in RUN or HOLD mode, irrespective of whether setting operation is done or not.

4) Remote ADV operation

The program advances to the start point of the next segment in RUN or HOLD mode, irrespective of whether setting operation is done or not.

5) Remote AT operation (AT function is option.)

Auto tuning is started, if AT is not being executed. Or it is stopped, if AT is being executed when setting operation is not done in RUN or HOLD mode.

6) Remote program number selection

Select a program number (No.1 to 7) by three switches when the remote RUN operation is done in the READY mode. Program No. 0 means the designation of a program which has already been selected by the console.

9.

EXTERNAL DIMENSIONS

External dimensions

[in mm]

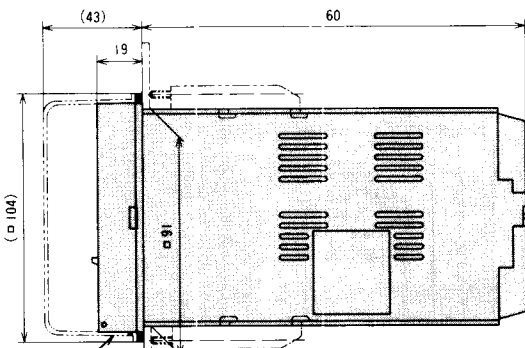
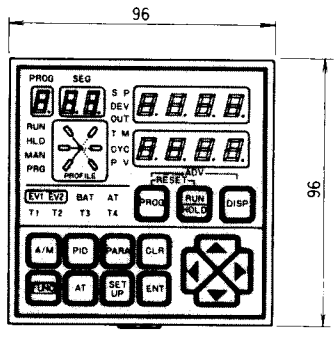

Packing, dust cover
8140330A (option)

Attached mounting bracket
81405411-001 or N-3174.

Panel cutout size

[in mm]

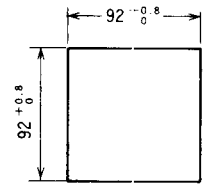
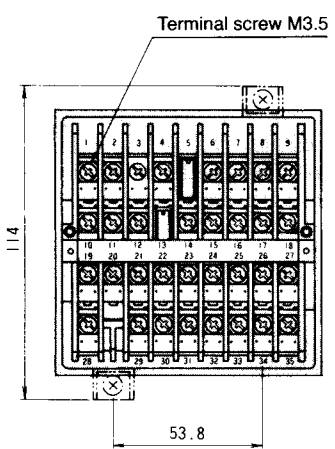

Panel cutout size

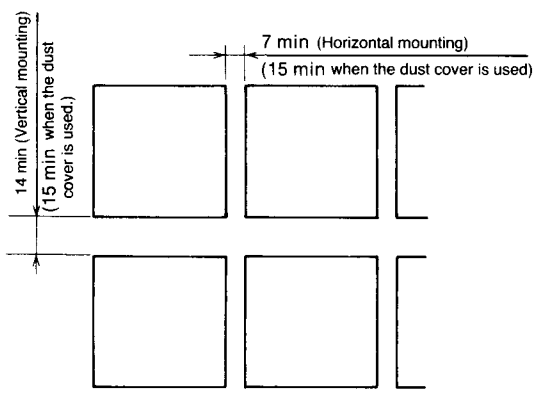

Vertical and horizontal mounting panel cutout sizes (recommendable)

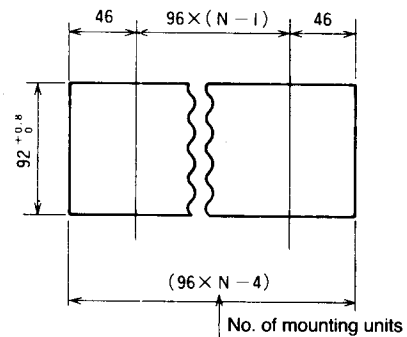

Panel cutout size for closed mounting (recommendable)

1. Mounting place

Mount the instrument at following places in the same way as in general digital electronic instruments.

- (1) A place free of any noticeable temperature change at normal temperature or so (within 0° to 50°C)
- (2) A place free of a corrosive gas atmosphere
- (3) A place not subjected to a low or high humidity (10 to 90% RH)
- (4) A place free of mechanical vibrations (less than 2 m/s², 10 to 60 Hz)
- (5) A place free of dust particles, soot, or the like
- (6) A place where is not affected by electrical noises
- (7) A place where is not subjected to a strong magnetic field
- (8) A place free of any flammable liquids or vapors.

2. Mounting method

- (1) Keep instrument within a mounting angle of 15°, if it is tilted down from the horizontal level on the rear side
- (2) Use a steel panel having a plate thickness of thicker than 2 mm.
- (3) Insert the instrument case from the panel cutout.
- (4) Fix the upper and lower panels of the instrument securely by using the attached mounting brackets.
- (5) Fix the panels to lower mounting bracket (1) first.
- (6) When the mounting brackets are flush against both a and b (where there is no longer any play between the mounting brackets and mounting panel), tighten the screw by about one turn. Do not tighten the screws too hard. Doing so might deform the case.

The controller must be mounted on a mounting panel, and its terminals covered to prevent electrical shock.

An optional terminal cover (Part No.: 81446084-002) is so separately.

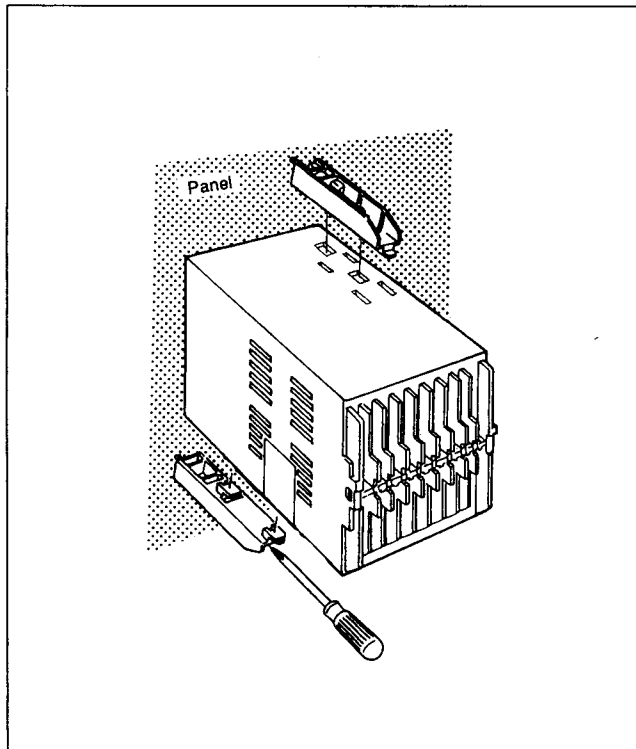

Fig. 10-1 Mounting method

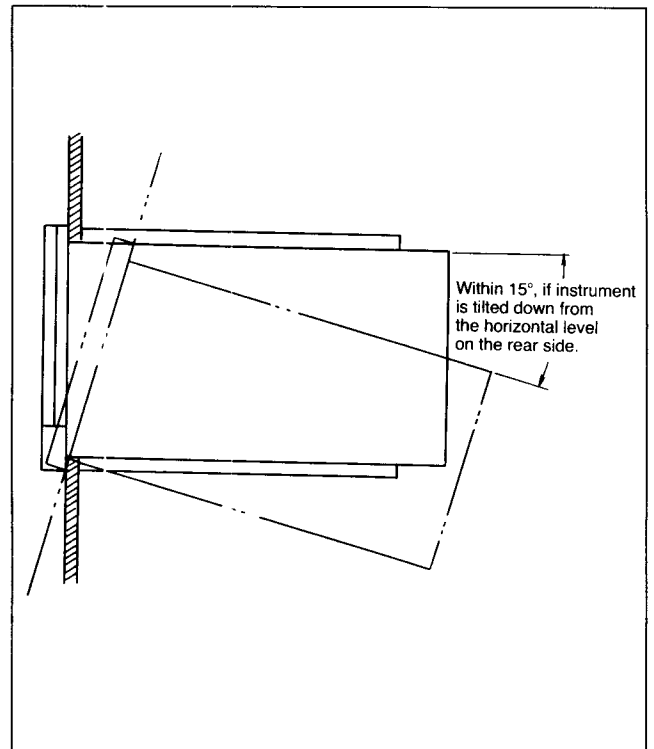

Fig. 10-2 Mounting angle

Caution: Use shielded cables for the DCP200 input/output cables so as not to introduce noises.

1. Cautions on wiring

- (1) Digital units are apt to be affected by electrical noises, so that a trouble and a wrong operation may be caused by those which are negligible for analog units. In order to prevent an effect of noises, connect cables with due care according to the instructions of this chapter.
- (2) Use solderless terminals conforming to M3.5 screws.
- (3) Connect cables according to the wiring diagram of the corresponding model number after confirming the instrument model number. After wiring, check them for normal conditions.
- (4) Separate input/output signal cables from a power cable as far as possible. Don't pass both cables through the same conduit or duct.

2. Input/output signal cables

2.1 Thermocouple input signal cable

- (1) Connect a thermocouple line cable to terminals in case of a thermocouple input. Connect the thermocouple input by extending it with a compensating lead wire, if the wiring distance is long or a sensor is connected to terminals.
Use a shielded compensating lead wire.

2.2 Input signal cables for those other than thermocouples, and digital input/output signal cables

- (1) Use a shielded polyethylene insulated vinyl sheathed cable for instrumentation use conforming to JCS-364 or equivalent (generally called a twisted shielded for instrumentation use).
- (2) A shielded multiconductor microphone cord (MVVS) may be used, if electromagnetic induction noises are comparatively low.

References Recommendable commercially available twisted shielded cables (JAPAN)

Fujikura Cable Co.	2 con- ductors	IPEV-S-0.9 mm ² ×1 P
	3 con- ductors	ITEV-S-0.9 mm ² ×1 T
Hitachi Cable Co.	2 con- ductors	KPEV-S-0.9 mm ² ×1 P
	3 con- ductors	KTEV-S-0.9 mm ² ×1 T

2.3 Remote switch input contact

- (1) Use a no-voltage remote switch input and a micro-current contact.
- (2) Hold a contact signal for longer than one second.

2.4 Signal cables for communication use (additional function)

- (1) Be careful since the communication circuit may be broken, if (+) and (--) communication terminals are shorted with each other.
- (2) Don't connect the DCP200 together with another instrument connected to the same RS-422 communication line to the same addresses.
(Zero has no communication)

3. Grounding

- (1) Connect the instrument by one-point grounding to G terminal. Don't perform any jumper wiring. Mount a grounding terminal board (earth bar) separately and connect shielded cables, etc. to ground as shown in Fig. 11-1, since only one G terminal is provided.
 - Grounding type: Category 3 grounding or higher (Lower than 100Ω)
 - Grounding wire: Annealed copper wire of more than 2mm² (AWG14)
 - Grounding wire length: Max. 20 m

4. Instrument power supply

- (1) Obtain the DCP200 power supply from a single-phase instrument power source in such a way as the instrument is not affected by noises as much as possible.

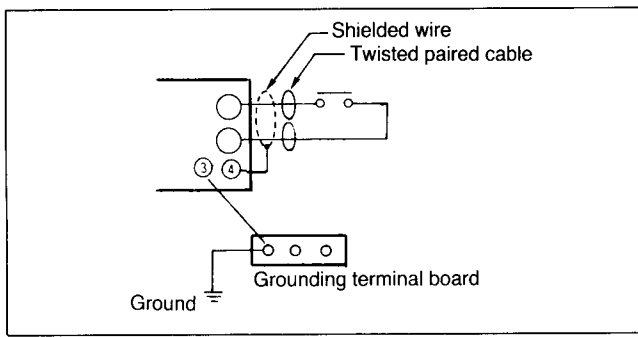

Fig. 11-1 Grounding method

(2) It is recommended to use a line filter having an additional insulation transformer, if noises are introduced noticeably from the power source.

- Line filter
Part number 81446364-001

Be careful not to bundle the primary and secondary of the power cable together or not to put them into the same conduit or duct after taking a countermeasure against noises.

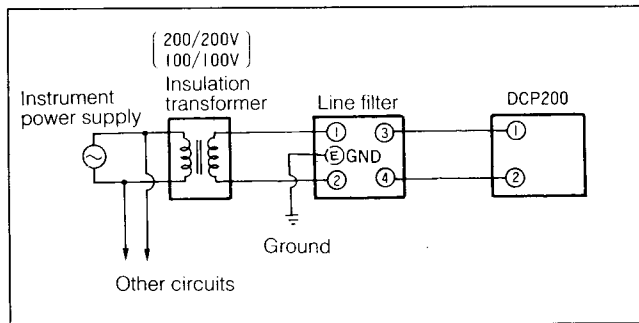

Fig. 11-2 Power noise reduction method

5. Noise generation sources and noise reduction methods

5.1 Noise generation sources

(1) The following noise generation sources are generally presumable.

- ① Relays and contacts
- ② Solenoid coils and solenoid valves
- ③ Power line (higher than 100 V ac, in particular)
- ④ Inductive load
- ⑤ Motor commutator
- ⑥ Phase angle control SCR
- ⑦ Radio communication equipment
- ⑧ Welding machine

5.2 Noise reduction method

(1) A CR filter is effective for quick-rising noises.

- Recommendable CR filter
Part number 81446365-001
(XEB120033 manufactured by Matsuo electric or equivalent)

(2) A varistor is effective for noises having a high crest value. Be careful since the varistor is shorted, if it becomes defective.

- Recommendable varistor
Part number 81446366-001 for 100 V use
81446367-001 for 200 V use.

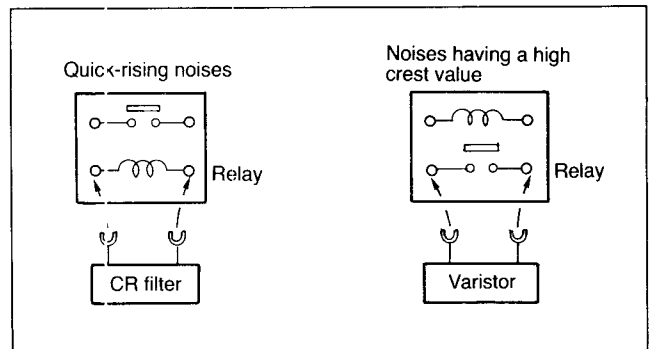
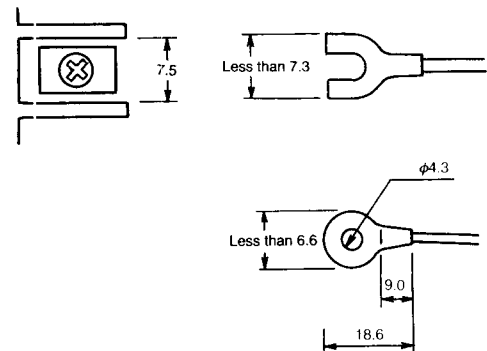

Fig. 11-3 Noise reduction method

For terminal connection, use solderless terminals conforming to M3.5 screws.



(Note) Use circular solderless terminals so that cables are not disconnected from terminals, if the instrument is mounted at a place subjected to noticeable vibrations and impacts.

External terminal layout

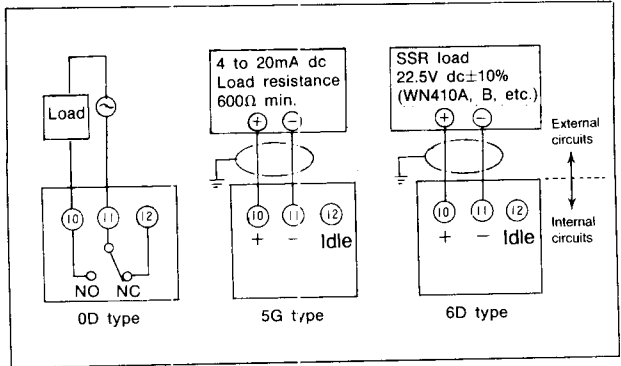
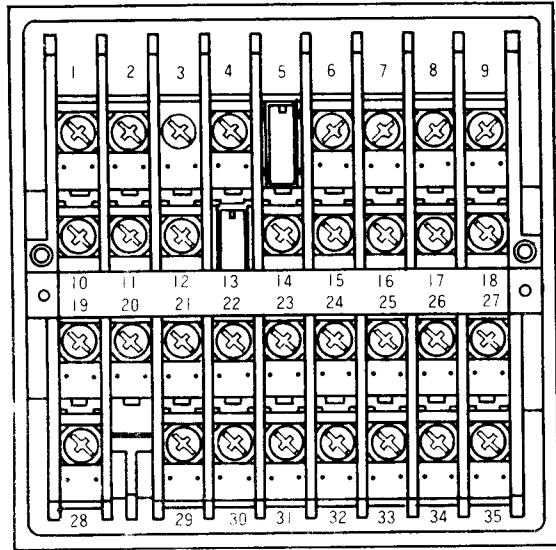
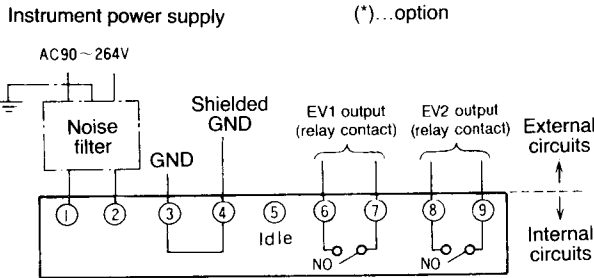

Fig. 12-1 MV output

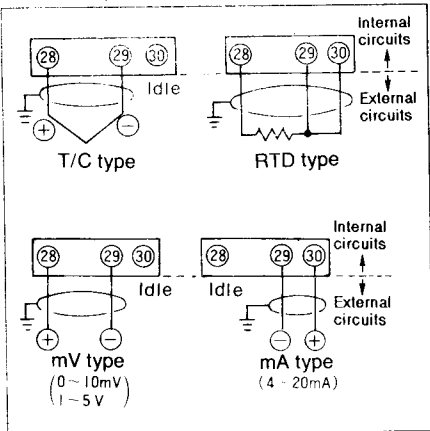
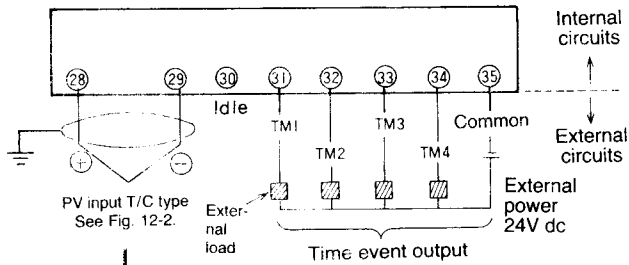

Fig. 12-2 PV input

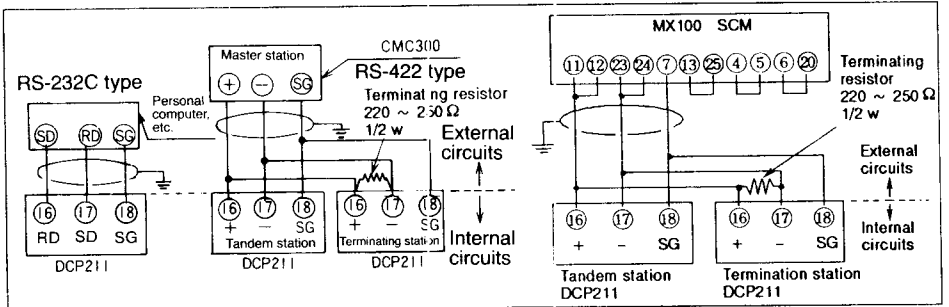
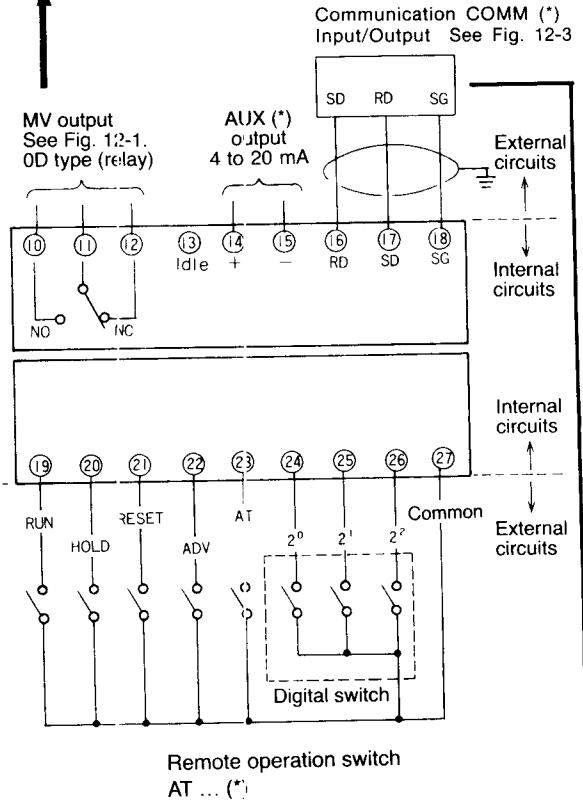





Fig. 12-3 COMM input/output (*)

- A switch in the main supply is required near the equipment.
- Mains power supply wiring requires a (T) 2A, 250V fuse(s). (IEC127)

The following table shows the meanings of symbols in the terminal wiring label on the instrument top.

Symbol	Description
	Alternating current
	Earth (ground) terminal
	Caution, risk of electric shock
	Caution (refer to accompanying documents)

13.

MAINTENANCE

Cleaning: Clean the instrument with a soft, dry cloth when it becomes dirty.

Replacing Parts: Only authorized personnel are allowed to replace parts.

Replacing Fuses: When replacing fuses provided on the power supply circuit, use only standard parts specified below.

Standard	IEC 127
Type	Time-lag (T)
Voltage rating	250 V
Current rating	2 A

APPENDIXES

- (1) Program pattern preparation example**
- (2) Setup setting example**
- (3) Parameter setting example**
- (4) Programming example**
- (5) Program work sheet**

(1) Program preparation example

Program No.:

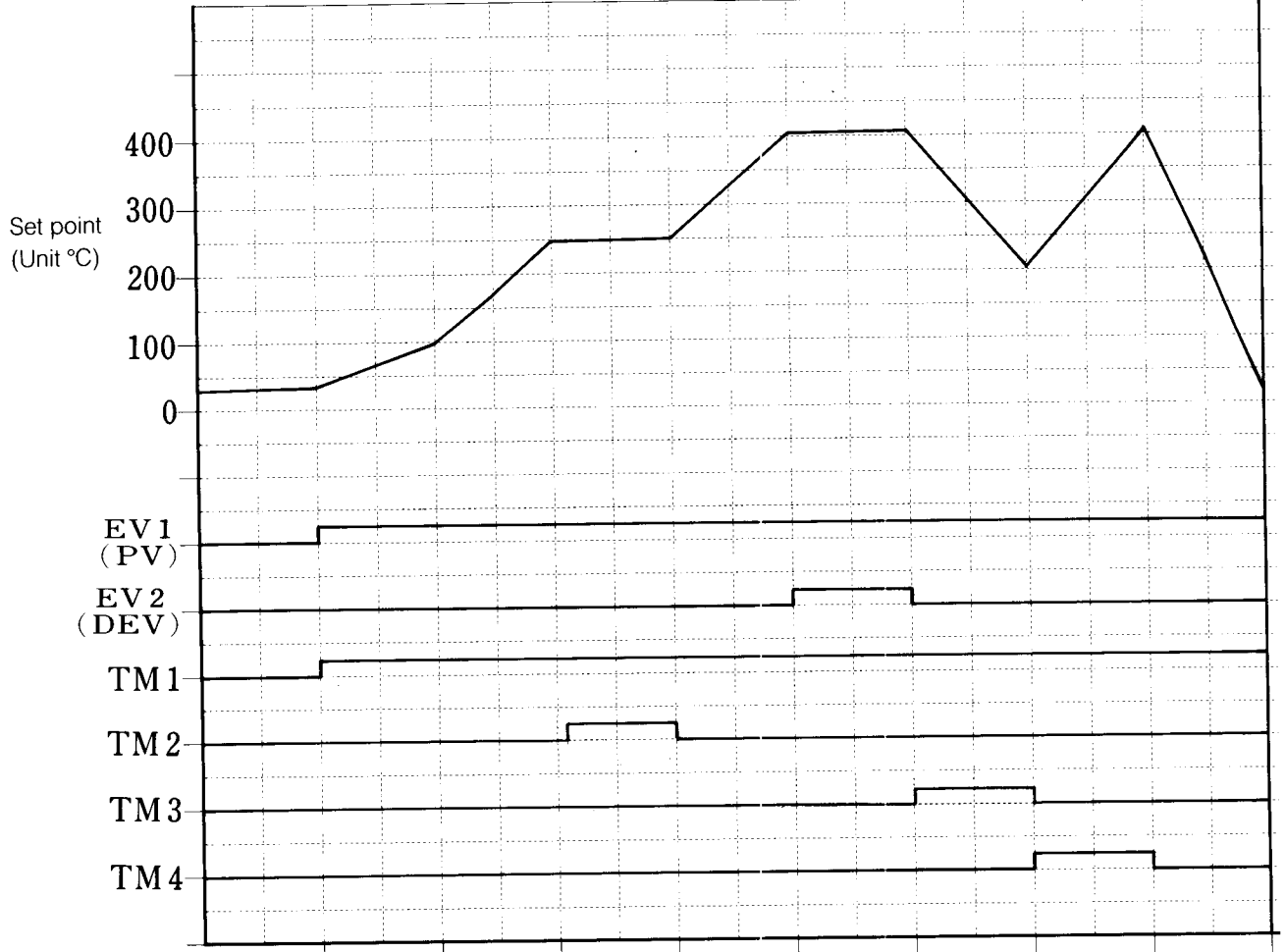

Programming map

Map position	Segment item	1	2	3	4	5	6	7	8	9			
A	SP time	Upper-display	S P	30	100	250	250	400	400	200	400	30	
		Lower-display	Time	2.00	4.00	3.00	7.00	4.00	7.00	4.00	4.00	4.00	
B	Event No.1	Upper-display	—										
		Lower-display	Set point (PV)	100									
C	Event No.2	Upper-display	—										
		Lower-display	Set point (DEV)	5	(DEV)	5	(DEV)	500					
D	Time event No.1	Upper-display	ON	0.00									
		Lower-display	OFF	37.00									
E	Time event No.2	Upper-display	ON	1.00									
		Lower-display	OFF	7.00									
F	Time event No.3	Upper-display	ON						0.00				
		Lower-display	OFF						7.00				
G	Time event No.4	Upper-display	ON								0.00		
		Lower-display	OFF								4.00		
H	PID group selection	Upper-display	P i d										
		Lower-display	Group No.	1	1	1	1	2	2	2	3	3	
I	G.SOAK setting	Upper-display	9.5										
		Lower-display	no or YES	no	no	no	YES	no	no	no	no	no	
J	PV start setting	Upper-display	P S t P										
		Lower-display	no or YES	YES	YES	YES	YES	YES	YES	YES	YES	YES	
K	Cycle setting	Upper-display	C Y C L										
		Lower-display	Cycle No.	0	0	0	0	0	0	0	0	0	

(Note) Set the max value of segment 7 DEV so as not to allow EV2 to function between segments 7 to 9. -50% FS to +50% FS

(2) Setup setting example

SET UP Setup setting procedure

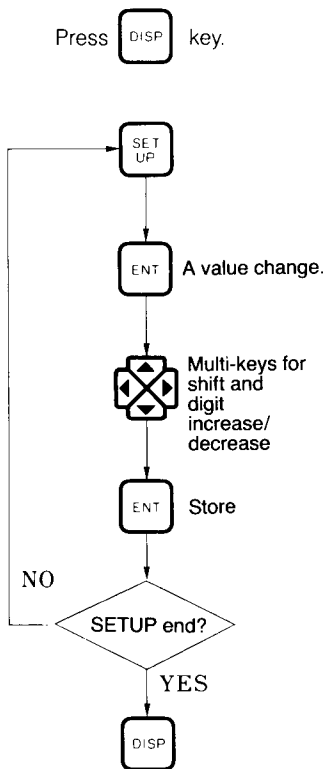

Step	Key operation	Display	Description of display	Remarks
1	Press key.		Proceed to the next step, since the initial value is the preset value before delivery from factory.	See pages 18 and 20.
16	Press key.		Program time unit is minute and second. (/: Minue and second)	
17	Press key.		flashes.	
18	Press this key.		Digit 1 is displayed.	
19	Press key.		1 is set.	
20	Press key.	SP TM	SETUP has finished.	C30 to C33 are not related to setup.

(3) Parameter setting example

PARAM Parameter setting procedure

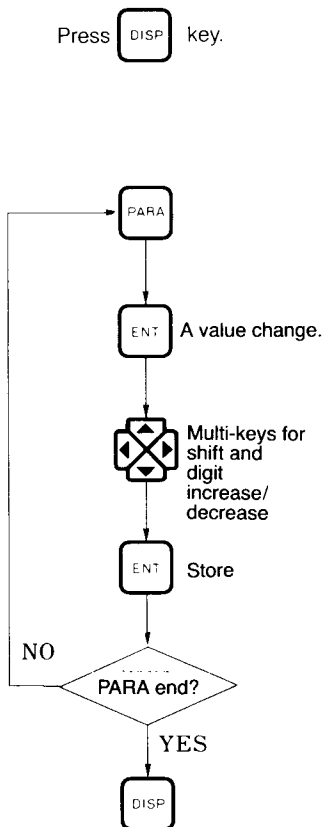

Step	Key operation	Display	Description of displays	Remarks
1	Press key.		Proceed to the next step, since the initial value is the preset value before delivery from factory.	See pages 24 and 25.
9	Press key.		Change initial value for setting DEV of event No.2.	
10	Press key.		The last digit flashes.	
11	Press this key.		Change the digit to 2.	Initial value 2: Deviation
12	Press key.		The higher side of the (+) DEV set point is on.	
13	Press key.		Set the DEV event on-off range to 5°C in event No.2. There is no change because the initial value is 5.	
14	Press key.	SP TM	Parameters setting has finished.	

(4) Programming example

Programming setting procedure

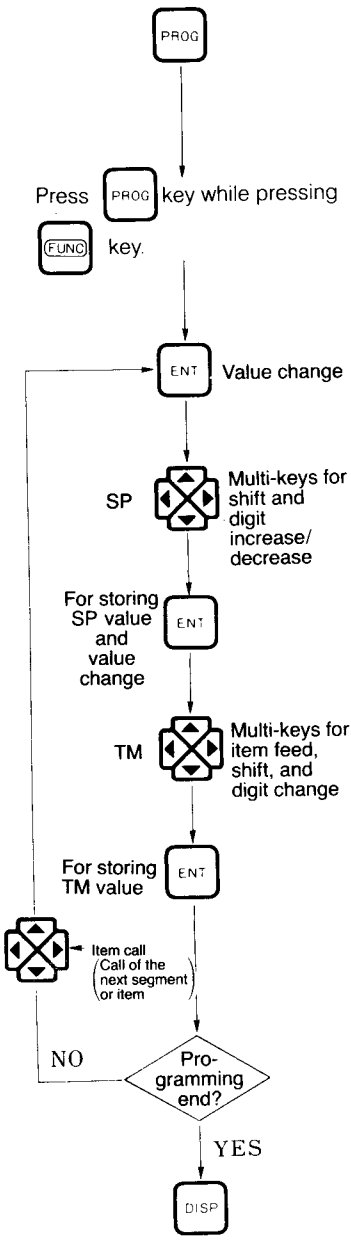

Step	Key operation	Display	Description of displays	Display of profile
1	Press key.		A program No. is assigned. SP, TM LEDs light.	
2	Press key while pressing key.		Programming mode is set. PRG LED lights. decimal point lights.	
3	Press key.		Segment 1 The last digit of SP flashes. SP value setting (Temperature is set to °C.)	
4	Press this key first, and then, press this key.		After pressing shift (left) key, change the flashing digit by a digit increase key. Set SP=30 (°C).	
5	Press key.		The last digit of TM flashes. TM value setting. (Time unit is set to minute/second.)	
6	Press this key first, and then, press this key.		Press shift (left) key, and then, change the flashing digit by a digit increase key. Set TM=2.00 (min.)	
7	Press key.		SP=30°C and TM=2 min have been stored.	
8	Press this key.		Segment 2	
9	Press key.		SP value setting	
10	Repeat step 4.		SP=100(°C) is set.	
11	Press key.		TM value setting	
12	Repeat step 6.		TM=4.00 (min) is set.	
13	Press key.		SP=100°C and TM=4 min have been stored.	
	Press key.		Segment 9 PROG SEG: 1. 9. SP=30°C and TM=4 min have been stored.	

	Step	Key operation	Display	Description of displays	Display of profile
PV event	1	Press this key.		PRG LED lights continuously. PV EV1 LED lights.	
	2	Press this key.		Press an item feed (right) key continuously until appears.	
	3	Press key.		The last digit of PV value flashes.	
	4	Press this key twice.		Shift	
	5	Press this key.		100 is displayed.	
	6	Press key.		PV event 100°C is set.	
DEV event	7	Press this key.		DEV EV2 LED lights when appears.	
	8	Press this key (four times)		Stop pressing the key when appears.	
	9	Press key.		The last digit flashes.	
	10	Press this key.		5 is displayed.	
	11	Press key.		DEV event 5°C is set.	
	12	Press this key.		is displayed.	
	13	Press key.		The last digit flashes.	
	14	Press this key first, and then, press this key.		600 is displayed.	
	15	Press key.		DEV event 600°C is set.	

	Step	Key operation	Display	Description of display	Display of profile
Time event	16	Press this key.		T1 LED lights in ^{SEG} 7.	
	17	Press this key. (four times)		Stop pressing the key when ^{SEG} 2. appears.	
	18	Press key.		The last digit flashes.	
	19	Press this key first, and then, press this key.		0.00 is displayed.	
	20	Press key.		T1 time event ON is set to 0 min.	
	21	Press this key first, and then, press this key.		37.00 is displayed.	
	22	Press key.		T1 time event OFF is set to 37 min.	
	23	Repeat 16 to 21 steps. Press key.		^{SEG} 4. T2 LED ON is set to 1 min. OFF is set to 7 min.	
	24	Repeat 16 to 21 steps. Press key.		^{SEG} 5. T3 LED ON is set to 0 min. OFF is set to 7 min.	
	25	Repeat 16 to 21 steps. Press key.		^{SEG} 8. T4 LED ON is set to 0 min. OFF is set to 4 min.	
PID	26	Press this key.		<i>P I d</i> is displayed in ^{SEG} 8. Since segments 1 to 4 apply to 1 group, go to segment 5.	
	27	Press this key.		^{SEG} 5. is displayed.	
	28	Press key.		PID 1 flashes.	
	29	Press this key.		No.2 PID group is set to segment 5.	
	30	Repeat 27 to 30 steps. Press key.		No.2 PID group is applied to segment 5 to 6. No.3 PID group is applied to segments 7 to 9.	

	Step		Display		Display of profile
Guaranteed soak	31	Press this key.	g.S. no	3.5 (guaranteed soak) and no are displayed in ^{SEG} 9.	
	32	Press this key. (four times)	g.S. no	Display ^{SEG} 4.	
	33	Press key.	g.S. no		
	34	Press this key.	g.S. YES		
	35	Press key.	g.S. YES	Guaranteed soak is set in segment 4.	
PV event	36	Press this key.	P.S t A no	PV start YES or NO may be set in an optional segment.	
	37	Press key.	P.S t A no		
	38	Press this key.	P.S t A YES		
	39	Press key.	P.S t A YES	YES is set for PV start.	
Cycle	40	Press this key.	CYCL 0	Since no cycle is required, 0 is set.	
	41	Press key.	 	Programming ends. After verifying with keys again, press key.	

WORKSHEET FOR DCP211 SETUP, PARAMETER AND PID VALUE SETTING

Client

Model No.

Equipment Name :	Product Name :

D	C	P	2	1	1						
Tag Name											

Application Engineer	
Salesman	
Date	

1. Setup

No.	Indication, set point value at the delivery time from factory	Item	Client's set point																
1	E 1 0	Key lock 0 : No key lock 1 : SETUP change is not allowable. 2 : Setting data are not changeable. 3 : DISP key only is changeable.	E 1 0																
2	E 2 0	Temperature unit 0 : Centigrade (°C) 1 : Fahrenheit (°F) T/C and RTD inputs only are displayed.	E 2 0																
3	E 3 0	Control action 0 : Reverse action 1 : Direct action	E 3 0																
4	E 4 0	MV at PV overrange 0 : Not provided 1 : Provided	E 4 0																
5	E 5 0.0	Setting value at PV overrange 0.0 to 100.0% (Time proportional type) -10.0 to +110.0% (Current output type) Displayed only when 1 in C4.	E 5 0.0																
6	E 6 0	0 to 12 (T/C) 20 to 35 (RTD) 40 to 45 (Linear)	E 6 0																
7	E 7 0	Linear PV decimal point position 0 = <table style="display: inline-table; border: none;"><tr><td style="border: 1px solid black; width: 15px; height: 15px;"></td><td style="border: 1px solid black; width: 15px; height: 15px;"></td><td style="border: 1px solid black; width: 15px; height: 15px;"></td><td style="border: 1px solid black; width: 15px; height: 15px;"></td></tr></table> 1 = <table style="display: inline-table; border: none;"><tr><td style="border: 1px solid black; width: 15px; height: 15px;"></td><td style="border: 1px solid black; width: 15px; height: 15px;"></td><td style="border: 1px solid black; width: 15px; height: 15px;"></td><td style="border: 1px solid black; width: 15px; height: 15px;"></td></tr></table> 2 = <table style="display: inline-table; border: none;"><tr><td style="border: 1px solid black; width: 15px; height: 15px;"></td><td style="border: 1px solid black; width: 15px; height: 15px;"></td><td style="border: 1px solid black; width: 15px; height: 15px;"></td><td style="border: 1px solid black; width: 15px; height: 15px;"></td></tr></table> 3 = <table style="display: inline-table; border: none;"><tr><td style="border: 1px solid black; width: 15px; height: 15px;"></td><td style="border: 1px solid black; width: 15px; height: 15px;"></td><td style="border: 1px solid black; width: 15px; height: 15px;"></td><td style="border: 1px solid black; width: 15px; height: 15px;"></td></tr></table> Linear type only displayed.																	E 7 0
8	E 8 0	Linear PV lower-limit -1999 to upper-limit U Linear type only is displayed.	E 8 0																
9	E 9 1000	Linear PV upper-limit Lower-limit to 9999U Linear type only is displayed.	E 9 1000																
10	E 10 0	SP limit lower-limit 0% to upper-limit of range	E 10 0																
11	E 11 100	SP limit upper-limit Lower-limit to 100% of range	E 11 100																

No.	Indication, set point value at the delivery time from factory	Item	Client's set point
12	E 12 0	Type of main output 0 : MV 1 : SP Current output type only is displayed.	E 12 0
13	E 13 0	Setting of SP4mA -1999 to +9999U Displayed only when 1 in C12. Current output type only is displayed.	E 13 0
14	E 14 100	Setting of SP20mA -1999 to +9999U Displayed only when 1 in C12. Current output type only is displayed.	E 14 100
15	E 15 0	Type of auxiliary output 0 : PV 1 : SP Displayed only when auxiliary output is provided.	E 15 0
16	E 16 0	Setting of auxiliary output 4mA -1999 to +9999U Displayed only when auxiliary output is provided.	E 16 0
17	E 17 100	Setting of auxiliary output 20mA -1999 to +9999U Displayed only when auxiliary output is provided.	E 17 100
18	E 18 0	Display at programming of EV1.2 0 : Displayed 1 : Not displayed	E 18 0
19	E 19 0	Display at programming of T1 to T4 0 : Displayed 1 : Not displayed	E 19 0
20	E 20 0	Display at programming of PID G.SOAK 0 : Provided 1 : Not provided	E 20 0
21	E 21 0	Display at programming of PV start, cycle, and pattern link. 0 : Not provided 1 : Provided	E 21 0
22	E 22 0	Communication address 0, 1 to 254 Displayed only when communication is provided.	E 22 0
23	E 23 0	Communication speed 0 : 9600 (BPS) 1 : 4800 2 : 2400 3 : 1200 Displayed only when communication is provided.	E 23 0

No.	Indication, set point value at the delivery time from factory	Item	Client's set point
24	C 2 4 0	Communication code 0 : 8 bits, even parity bit, 1 stop bit 1 : 8 bits, not parity bit, 2 stop bits Displayed only when communication is provided.	C 2 4
26	C 2 6 0	PV display 1 : Displayed 2 : Not displayed 3 : Not displayed when fixed at 0% of range.	C 2 6
27	C 2 7 0	Time display 0 : Segment remaining time 1 : Operation progress time	C 2 7
28	C 2 8 0	Alarm display 0 : Displayed 1 : Not displayed	C 2 8
29	C 2 9 0	Time unit of program 0 : min/hr 1 : sec/min	C 2 9

2. Parameter

No.	Indication, set point value at the delivery time from factory	Item	Client's set point
1	P r t c 0	Program protect 0 : Protected 1 : Not protected	P r t c
2	F I L t 0.0	PV filter constant 0.0 to 120.0 sec.	F I L t
3	P b i a 0	PV bias -100 to +100U	P b i a
4	S b i a 0	SP bias -50 to +50% FS	S b i a
5	G . S . o a k 5	G.SOAK 0 to 100U	G . S . o a k
6	c y 1 0	Time proportional output cycle 5 to 120 sec. (Relay type) 1 to 60 sec. (Voltage type) 00 and 60 types only are displayed.	c y
7	o u t l 1 0 0 . 0	Manipulated variable change limit 0.0 to 100.0 (Every 0.5 sec.)	o u t l
8	d i f f 5	ON/OFF control differential 0 to 100U Displayed only in 0D, and 6D types.	d i f f
9	E t 1 0	Selection of event 1 0 : PV (Direct) 1 : PV (Reverse) 2 : Deviation (Direct) 3 : Deviation (Reverse) 4 : RUN 5 : READY 6 : END	E t 1
10	H y s 1 5	Event 1 hysteresis 0 to 100U	H y s 1
11	E t 2 0	Selection of event 2 0 : PV (Direct) 1 : PV (Reverse) 2 : Deviation (Direct) 3 : Deviation (Reverse) 4 : RUN 5 : READY 6 : END	E t 2
12	H y s 2 5	Event 2 hysteresis 0 to 100U	H y s 2
13	r P i d 0	PID operation initialize at advance 0 : PID operation is not initialized. 1 : PID operation is initialized.	r P i d

3. PID constant setting

No.	Indication, set point value at the delivery time from factory	Item	Client's set point
1	<div style="border: 1px solid black; padding: 2px; display: inline-block;">P t</div> <div style="border: 1px solid black; padding: 2px; display: inline-block;">0</div>	0 : AT is not executed 1 : Method 1 is executed by ATkey. 2 : Method 2 is executed by ATkey. Displayed only when auto tuning is provided.	<div style="border: 1px solid black; padding: 2px; display: inline-block;">P t</div> <div style="border: 1px solid black; padding: 2px; display: inline-block;"></div>
2	<div style="border: 1px solid black; padding: 2px; display: inline-block;">P - 1</div> <div style="border: 1px solid black; padding: 2px; display: inline-block;">1 0 0 . 0</div>	Proportional band 1 0.0 to 999.9% (Time proportional) 0.1 to 999.9% (Current output)	<div style="border: 1px solid black; padding: 2px; display: inline-block;">P - 1</div> <div style="border: 1px solid black; padding: 2px; display: inline-block;"></div>
3	<div style="border: 1px solid black; padding: 2px; display: inline-block;">I - 1</div> <div style="border: 1px solid black; padding: 2px; display: inline-block;">0</div>	Integral time 1 0 to 3600 sec. Displayed when P - 1 ≠ 0	<div style="border: 1px solid black; padding: 2px; display: inline-block;">I - 1</div> <div style="border: 1px solid black; padding: 2px; display: inline-block;"></div>
4	<div style="border: 1px solid black; padding: 2px; display: inline-block;">d - 1</div> <div style="border: 1px solid black; padding: 2px; display: inline-block;">0</div>	Derivative time 1 0 to 1200 sec. Displayed when P - 1 ≠ 0	<div style="border: 1px solid black; padding: 2px; display: inline-block;">d - 1</div> <div style="border: 1px solid black; padding: 2px; display: inline-block;"></div>
5	<div style="border: 1px solid black; padding: 2px; display: inline-block;">o L - 1</div> <div style="border: 1px solid black; padding: 2px; display: inline-block;">0 . 0</div> or <div style="border: 1px solid black; padding: 2px; display: inline-block;">- 1 0 . 0</div>	Manipulated variable lower-limit 1 0.0 to upper-limit % (Time proportional) -10.0 to upper-limit % (Current output) Displayed when P - 1 ≠ 0	<div style="border: 1px solid black; padding: 2px; display: inline-block;">o L - 1</div> <div style="border: 1px solid black; padding: 2px; display: inline-block;"></div>
6	<div style="border: 1px solid black; padding: 2px; display: inline-block;">o H - 1</div> <div style="border: 1px solid black; padding: 2px; display: inline-block;">1 0 0 . 0</div> or <div style="border: 1px solid black; padding: 2px; display: inline-block;">1 1 0 . 0</div>	Manipulated variable upper-limit 1 Lower-limit to 100.0% (Time proportional) Lower-limit to 110.0% (Current output) Outputted when P - 1 ≠ 0	<div style="border: 1px solid black; padding: 2px; display: inline-block;">o H - 1</div> <div style="border: 1px solid black; padding: 2px; display: inline-block;"></div>
7	<div style="border: 1px solid black; padding: 2px; display: inline-block;">r E - 1</div> <div style="border: 1px solid black; padding: 2px; display: inline-block;">5 0 . 0</div>	Manual reset 1 0.0 to 100.0% Displayed when P - 1 ≠ 0 and I ≠ 0	<div style="border: 1px solid black; padding: 2px; display: inline-block;">r E - 1</div> <div style="border: 1px solid black; padding: 2px; display: inline-block;"></div>
8	<div style="border: 1px solid black; padding: 2px; display: inline-block;">P - 2</div> <div style="border: 1px solid black; padding: 2px; display: inline-block;">1 0 0 . 0</div>	Proportional band 2 0.0 to 999.9% (Time proportional) 0.1 to 999.9% (Current output)	<div style="border: 1px solid black; padding: 2px; display: inline-block;">P - 2</div> <div style="border: 1px solid black; padding: 2px; display: inline-block;"></div>
9	<div style="border: 1px solid black; padding: 2px; display: inline-block;">I - 2</div> <div style="border: 1px solid black; padding: 2px; display: inline-block;">0</div>	Integral time 2 0 to 3600 sec. Displayed when P - 2 ≠ 0	<div style="border: 1px solid black; padding: 2px; display: inline-block;">I - 2</div> <div style="border: 1px solid black; padding: 2px; display: inline-block;"></div>
10	<div style="border: 1px solid black; padding: 2px; display: inline-block;">d - 2</div> <div style="border: 1px solid black; padding: 2px; display: inline-block;">0</div>	Derivative time 2 0 to 1200 sec. Displayed when P - 2 ≠ 0	<div style="border: 1px solid black; padding: 2px; display: inline-block;">d - 2</div> <div style="border: 1px solid black; padding: 2px; display: inline-block;"></div>
11	<div style="border: 1px solid black; padding: 2px; display: inline-block;">o L - 2</div> <div style="border: 1px solid black; padding: 2px; display: inline-block;">0 . 0</div>	Manipulated variable lower-limit 2 0.0 to upper-limit % (Time proportional) -10.0 to upper-limit % (Current output) Displayed when P - 2 ≠ 0	<div style="border: 1px solid black; padding: 2px; display: inline-block;">o L - 2</div> <div style="border: 1px solid black; padding: 2px; display: inline-block;"></div>

No.	Indication set point value at the delivery time from factory	Item	Client's set point
12	<div style="border: 1px solid black; padding: 2px; display: inline-block;">o H - 2</div> <div style="border: 1px solid black; padding: 2px; display: inline-block;">1 0 0 . 0</div> or <div style="border: 1px solid black; padding: 2px; display: inline-block;">1 1 0 . 0</div>	Manipulated variable lower-limit 2 Lower-limit to 100.0% (Time proportional) Lower-limit to 110.0% (Current output) Displayed when P - 2 ≠ 0	<div style="border: 1px solid black; padding: 2px; display: inline-block;">o H - 2</div> <div style="border: 1px solid black; padding: 2px; display: inline-block;"></div>
13	<div style="border: 1px solid black; padding: 2px; display: inline-block;">r E - 2</div> <div style="border: 1px solid black; padding: 2px; display: inline-block;">5 0 . 0</div>	Manual reset 2 0.0 to 100.0% Displayed when P - 2 ≠ 0 and I ≠ 0	<div style="border: 1px solid black; padding: 2px; display: inline-block;">r E - 2</div> <div style="border: 1px solid black; padding: 2px; display: inline-block;"></div>
14	<div style="border: 1px solid black; padding: 2px; display: inline-block;">P - 3</div> <div style="border: 1px solid black; padding: 2px; display: inline-block;">1 0 0 . 0</div>	Proportional band 3 0.0 to 999.9% (Time proportional) 0.1 to 999.9% (Current output)	<div style="border: 1px solid black; padding: 2px; display: inline-block;">P - 3</div> <div style="border: 1px solid black; padding: 2px; display: inline-block;"></div>
15	<div style="border: 1px solid black; padding: 2px; display: inline-block;">I - 3</div> <div style="border: 1px solid black; padding: 2px; display: inline-block;">0</div>	Integral time 3 0 to 3600 sec. Displayed when P - 3 ≠ 0	<div style="border: 1px solid black; padding: 2px; display: inline-block;">I - 3</div> <div style="border: 1px solid black; padding: 2px; display: inline-block;"></div>
16	<div style="border: 1px solid black; padding: 2px; display: inline-block;">d - 3</div> <div style="border: 1px solid black; padding: 2px; display: inline-block;">0</div>	Derivative time 3 0 to 1200 sec. Displayed when P - 3 ≠ 0	<div style="border: 1px solid black; padding: 2px; display: inline-block;">d - 3</div> <div style="border: 1px solid black; padding: 2px; display: inline-block;"></div>
17	<div style="border: 1px solid black; padding: 2px; display: inline-block;">o L - 3</div> <div style="border: 1px solid black; padding: 2px; display: inline-block;">0 . 0</div> or <div style="border: 1px solid black; padding: 2px; display: inline-block;">- 1 0 . 0</div>	Manipulated variable lower-limit 3 0.0 to upper-limit (Time proportional) -10.0 to upper-limit (Current output) Outputted when P - 3 ≠ 0	<div style="border: 1px solid black; padding: 2px; display: inline-block;">o L - 3</div> <div style="border: 1px solid black; padding: 2px; display: inline-block;"></div>
18	<div style="border: 1px solid black; padding: 2px; display: inline-block;">o H - 3</div> <div style="border: 1px solid black; padding: 2px; display: inline-block;">1 0 0 . 0</div> or <div style="border: 1px solid black; padding: 2px; display: inline-block;">1 1 0 . 0</div>	Manipulated variable upper-limit 3 Lower-limit to 100.0 (Time proportional) Lower-limit to 110.0 (Current output) Displayed when P - 3 ≠ 0	<div style="border: 1px solid black; padding: 2px; display: inline-block;">o H - 3</div> <div style="border: 1px solid black; padding: 2px; display: inline-block;"></div>
19	<div style="border: 1px solid black; padding: 2px; display: inline-block;">r E - 3</div> <div style="border: 1px solid black; padding: 2px; display: inline-block;">5 0 . 0</div>	Manual reset 3 0.0 to 100.0% Displayed when P - 3 ≠ 0 and I ≠ 0	<div style="border: 1px solid black; padding: 2px; display: inline-block;">r E - 3</div> <div style="border: 1px solid black; padding: 2px; display: inline-block;"></div>
20	<div style="border: 1px solid black; padding: 2px; display: inline-block;">I o u t</div> <div style="border: 1px solid black; padding: 2px; display: inline-block;">0 . 0</div>	PID operation Initial MV 0.0 to 100.0% Displayed, if at least one P=0 out of 1 to 3 groups.	<div style="border: 1px solid black; padding: 2px; display: inline-block;">I o u t</div> <div style="border: 1px solid black; padding: 2px; display: inline-block;"></div>

General PID Actions

1. Proportional band P

- (1) When the proportional band is wide, an overshoot is difficult to occur on arrival at the set point, but an offset from the set point is produced. When the proportional band is narrow on the contrary, an overshoot occurs and the control amplitude is waved as in on-off action.
 - The offset is reduced.
 - When the proportional band is minimized, the maximum and minimum control outputs are repeated, and the output amplitude is maximized. The offset is also minimized.
- (2) When the proportional band is narrowed, the following effect appear.
 - The offset is reduced.
 - When the proportional band is minimized, the maximum and minimum control outputs are repeated, and the output amplitude is maximized. The offset is also minimized.
- (3) In electric furnaces, the proportional band may be generally set to narrower than about 10%.

P control action

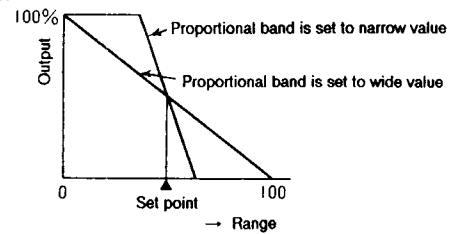

P control effect

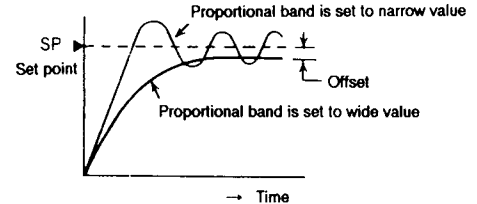

2. Ingeral I

- (1) The integral time functions in such a direction that the offset caused by the proportional control is eliminated as the time elapses.

If the integral time is shortened to eliminate the offset in a short time, the derivative action is intensified and the control is disturbed on the contrary, thus causing a hunting.

Therefore, change over the integral time from a long value to a short value, and find an optimum control constant.
- (2) As the integral value is shortened, the following effects appear.
 - The offset is reduced more speedily.
 - The control output amplitude is increased, thus causing a hunting.
- (3) In electric furnaces, the integral time may be generally set to shorter than about 150 sec.

I control action

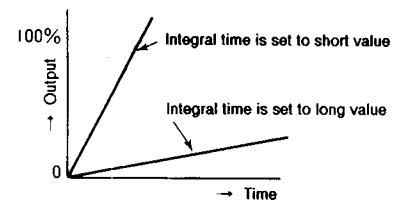

I control effect

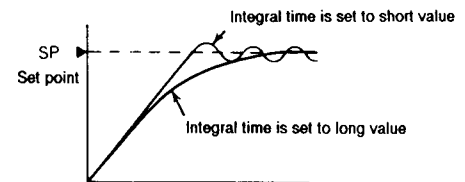

3. Derivative D

- (1) The derivative time functions to output a large manipulated variable against a sudden disturbance, and thereby restore the control to the original.

When the derivative time is made long, the large manipulated variable is activated for a long time, and therefore the control is caused to be disturbed on the contrary.

Therefore, change over the setting of the derivative time a short value to a long value, and find an optimum control constant.
- (2) As the derivative time becomes longer, the following effects appear.
 - Both the control output amplitude and time become smaller little by little.
 - The derivative time adjustment has no effect on the offset correction.
- (3) In electric furnaces, the derivative time may be generally set to longer than about 30 sec.
- (4) A optimum derivative value is generally about 1/4 of the integral value.

D control action

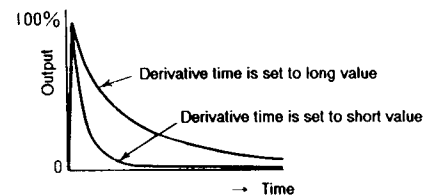

D control effect

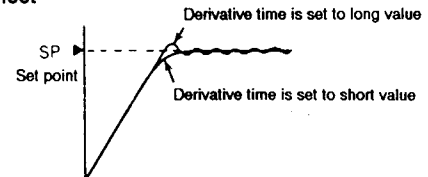

Specifications are subject to change without notice.

YAMATAKE

Yamatake Corporation

IBD Sensing and Control Department
Totate International Building
2-12-19 Shibuya Shibuya-ku Tokyo 150-8316 Japan
Phone: 81-3-3486-2311
Fax: 81-3-3486-2300

This has been printed on recycled paper.

Printed in Japan.
1st Edition: Issued in June, 1998
4th Edition: Issued in Sep., 2000(R)