

ST3000 Smart Transmitter Model JTD720

Differential Pressure Transmitter with Temperature and Pressure Compensation

OVERVIEW

The ST3000 Differential Pressure Transmitter with Temperature and Pressure Compensation is a microprocessor-based transmitter. The transmitter detects a differential pressure, a static pressure and temperature of a process fluid simultaneously to compensate the density change due to the static pressure and temperature changes and converts the differential pressure into an analog (4 to 20mA) or digital output signal which is proportional to the massflow (volumetric flow at a reference condition). The transmitter's parameters and settings (range, damping time constant, linear or square-root output, constant-current output and others) can be remote-controlled from the instrument room via the SFC (Smart Field Communicator) for the temperature and pressure compensation.

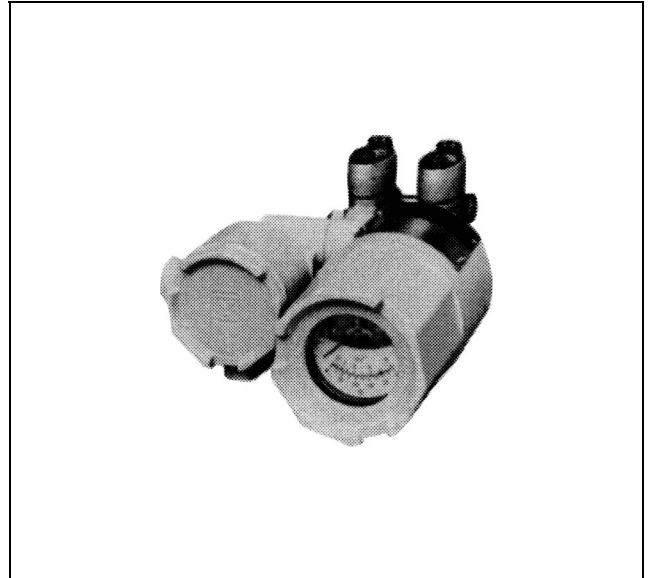

Standard Specifications

Item	Specifications
Measuring span	75 to 10000mmH ₂ O (0.74 to 98.1 kPa)
Setting range	-10000 ≤ URV (*1) ≤ 10000mmH ₂ O (- 98.1 ≤ URV ≤ 98.1 kPa) -10000 ≤ LRV (*1) ≤ 10000mmH ₂ O (- 98.1 ≤ LRV ≤ 98.1 kPa)
Output (After pressure and temperature compensation)	Analog output (4 to 20mA) Digital output
Designed pressure setting range	1.7 to 35kgf/cm ² abs. (0.17 to 3.43 MPa abs.)
Designed temperature setting range	-50 to + 300°C
Calculation equation	See Figure 1
Accuracy (Output after compensation)	Percentage with respect to x (mmH ₂ O) that represents the URV or LRV of the calibrated range, or the span-whichever is greatest. PP _{REF.} : Designed pressure (kgf/cm ² abs.) PP _{MAX.} : Maximum process pressure (kgf/cm ² abs.) ± 0.28% (at differential pressure 2500mm H ₂ O, designed pressure 5kgf/cm ² abs, designed temperature 100°C, maximum process pressure 6kgf/cm ² abs. maximum process temperature 150°C) Accuracies under various conditions are obtained by the following equations: Accuracy%= ± (0.05+A+B+C+D+E)
	A: $0.05\% \dots x \times \frac{PP_{REF.}}{PP_{MAX.}}$ is 1250mm H ₂ O or greater $0.05 \times \frac{1250}{x} \times \frac{PP_{MAX.}}{PP_{REF.}} \dots x \times \frac{PP_{REF.}}{PP_{MAX.}}$ is 1250mm H ₂ O or less
	B: $0.1 \times \frac{PP_{MAX.}}{35} \dots x \times \frac{PP_{REF.}}{PP_{MAX.}}$ is 2500mm H ₂ O or greater $0.1 \times \frac{2500}{x} \times \frac{PP_{MAX.}}{PP_{REF.}} \times \frac{PP_{MAX.}}{35} \dots x \times \frac{PP_{REF.}}{PP_{MAX.}}$ is 2500mm H ₂ O or less
	C: $0.05\% \dots PP_{REF.}$ is 3.5kgf/cm ² abs. or greater $0.05 \times \frac{3.5}{PP_{REF.}} \dots PP_{REF.}$ is 3.5kgf/cm ² abs. or less
	D: $0.15 \times \frac{x}{PP_{REF.} \times 10000}$
	E: 0.1% Square root output: When output is 50 to 100%; Same as that of linear output. When output is 7 to 50%; Value of linear output x 50 square root output % (Dropout area is not specified.) When output is 7% or less; Not specified.
Low flow cut	Cut off value: 0 to 20% of output adjustable Dropout type: Zero or linear output
Supply voltage	17.5 to 45V DC (See Figure 2.)
Working pressure rating	35kgf/cm ² abs. (3.43 MPa abs.) max.(For vacuum pressures, see Figure 3.)
Operating temperature range	Ambient and meter body (process fluid) temperature: Normal operating conditions; -15 to +65° Operative limits; -40 to +70°C Transportation and storage conditions; -50 to +85°C
Operating humidity range	Normal operating conditions: 5 to 100% RH
Temperature effect (After compensation)	Percentage with respect to x (mmH ₂ O) that represents the URV or LRV of the setting range, or the span-whichever is greatest. PP _{REF.} : Designed pressure (kgf/cm ² abs.) PP _{MAX.} : Maximum process pressure (kgf/cm ² abs.) Zero shift:
	±0.40%/30°C (at differential pressure 2500mmH ₂ O, designed pressure 5kgf/cm ² abs., designed temperature 100°C, maximum process pressure 6kgf/cm ² abs. and maximum process temperature 150°C)
	Zero shifts under various conditions are obtained by the following equations: Zero shift%/30°C = ± (0.15+A+B+D) A: $0.06 \times \frac{1250}{x} \times \frac{PP_{MAX.}}{PP_{REF.}}$ B: $0.08 \times \frac{2500}{x} \times \frac{PP_{MAX.}}{35} \times \frac{PP_{MAX.}}{PP_{REF.}}$ D: 0.20%

Item	Specifications
Temperature effect (After compensation) - continued	<p>Combined shift (including zero and span shifts): $\pm 0.62\%/30^\circ\text{C}$</p> <p>(at differential pressure 2500mmH₂O, designed pressure 5kgf/cm² abs., designed temperature 100°C, maximum process pressure 6kgf/cm² abs. and maximum process temperature 150°C)</p> <p>Combined shifts under various conditions are obtained by the following equations: Combined shift%/30°C = $\pm (0.2+A+B+C+D)$</p> <p>A: $0.1\% \dots x \frac{PP_{REF.}}{PP_{MAX.}}$ is 1250mm H₂O or greater</p> $0.1 \times \frac{1250}{x} \times \frac{PP_{MAX.}}{PP_{REF.}} \% \dots x \times \frac{PP_{REF.}}{PP_{MAX.}}$ is 1250mm H ₂ O or less <p>B: $0.08 \times \frac{PP_{MAX.}}{35} \% \dots x \frac{PP_{REF.}}{PP_{MAX.}}$ is 2500mm H₂O or greater</p> $0.08 \times \frac{2500}{x} \times \frac{PP_{MAX.}}{PP_{REF.}} \times \frac{PP_{MAX.}}{35} \% \dots x \times \frac{PP_{REF.}}{PP_{MAX.}}$ is 2500mm H ₂ O or less <p>C: $0.1\% \dots PP_{REF.}$ is 3.5 kgf/cm² abs. or greater</p> $0.1 \times \frac{3.5}{PP_{REF.}} \% \dots PP_{REF.}$ is 3.5kgf/cm ² abs. or less <p>D: 0.20%</p>
Accuracy and calibration accuracy for differential pressure transmitter	<p>Percentage with respect to x (mmH₂O) that represents the URV or the LRV of the setting range or the span-whichever is greatest.</p> <p>Linear output: $\pm 0.1\% \dots x$ is 1250mm H₂O or greater.</p> $\pm (0.05 + 0.05 \times \frac{1250}{x})\% \dots x$ is 1250mm H ₂ O or less
Calibration accuracy for pressure transmitter	<p>Percentage with respect to x (mmH₂O) that represents the URV or the LRV of the setting range or the span-whichever is greatest.</p> <p>$\pm 0.1\% \dots x$ is 3.5kgf/cm² abs. or greater.</p> $\pm (0.05 + 0.05 \times \frac{3.5}{x})\% \dots x$ is 3.5kgf/cm ² abs. or less
Calibration accuracy for temperature transmitter	<p>$-50^\circ\text{C} \leq \text{LRV}, \text{URV} \leq 300^\circ\text{C}$, span is 50°C or greater</p> $\pm (0.3 \times \frac{50}{\text{span}} + 0.05)\% \text{FS}$
Temperature input type	Resistance thermo-bulb Pt 100Ω or JPt Ω
Stability against supply voltage change	0.005% FS/V

Dead time	Approx. 0.6 sec.
Damping time constant	Adjustable within a range of 0.6 to 32 sec. (at 25°C)
Process connection	Rc½, ½NPT, Rc¼, ¼NPT internal thread
Electrical conduit connection	G½ internal thread
Structure	Waterproof and dustproof structure: JIS C0920 watertight, JIS F8001 Class 2 watertight, NEMA 3 and 4X, IEC IP67
Materials	Center body: SUS316 Wetted parts of center body: SUS316 (SUS316L for diaphragm only) Meter body cover (Differential pressure chambers): Carbon steel (SF45A), SUS316 Bolts: SNB7 Nuts: S45C Gasket: Teflon Transmitter case: Aluminum alloy
Finish	Baked acryl paint, light beige (Munsell 4Y7.2/1.3)
Installation	Can be installed on a 2-inch horizontal or vertical pipe. (Can be directly mounted on a process pipe.)
Weight	Approx. 7.5kg

(*1): URV denotes the value for 100% (20mA DC) output.

(*2): LRV denotes the value for 0% (4mA DC) output.

Optional Specifications

(The items other than the following are identical with those of the Standard Specifications.)

Item	Specifications
Built-in indicating meter (Class 2.5)	Ambient temperature: Normal operating conditions; -10 to +60°C Operative limits (For short period) and transportation and storage conditions; -40 to +85°C
Corrosion-resistant finish	Corrosion-resistant paint (Baked acryl paint), fungus-proof finish. (Silver paint when meter body cover, adaptor flanges, bolts, nuts, and manifold valves are made of carbon steel)
Corrosion-proof finish	Corrosion-proof paint (Baked epoxy paint), fungus-proof finish. (Silver paint when meter body cover, adaptor flanges, bolts, nuts, and manifold valves are made of carbon steel)
Corrosive-resistant finish (Silver paint)	Transmitter case is silver-painted in addition to the above corrosion-resistant finish.
Flameproof-packing-type cable connecting adaptor	For electrical connection by the leading-in method of flameproof-packing type for special flameproof structure.
Explosion-proof structure	JIS C0903 ds2G4 special flameproof structure (Ambient temperature: -10 to +60°C Meter body (Process fluid) temperature: -10 to +65°C

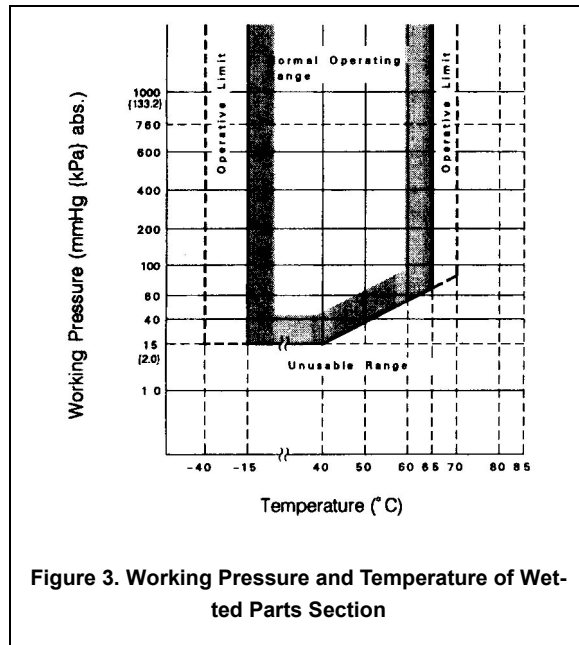
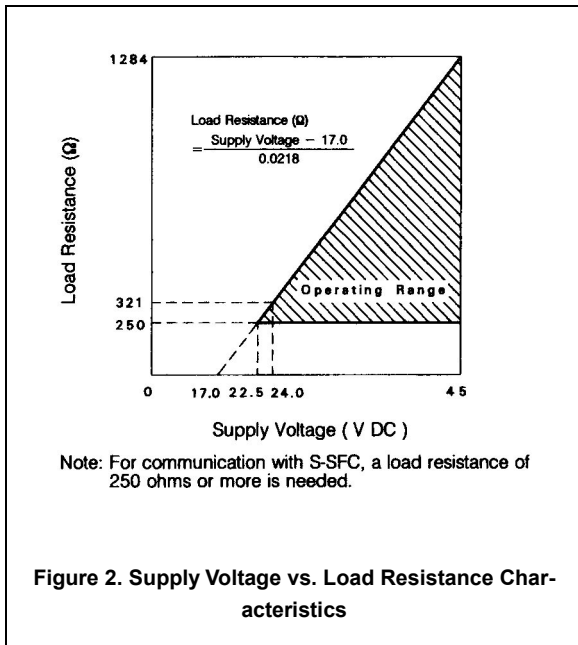
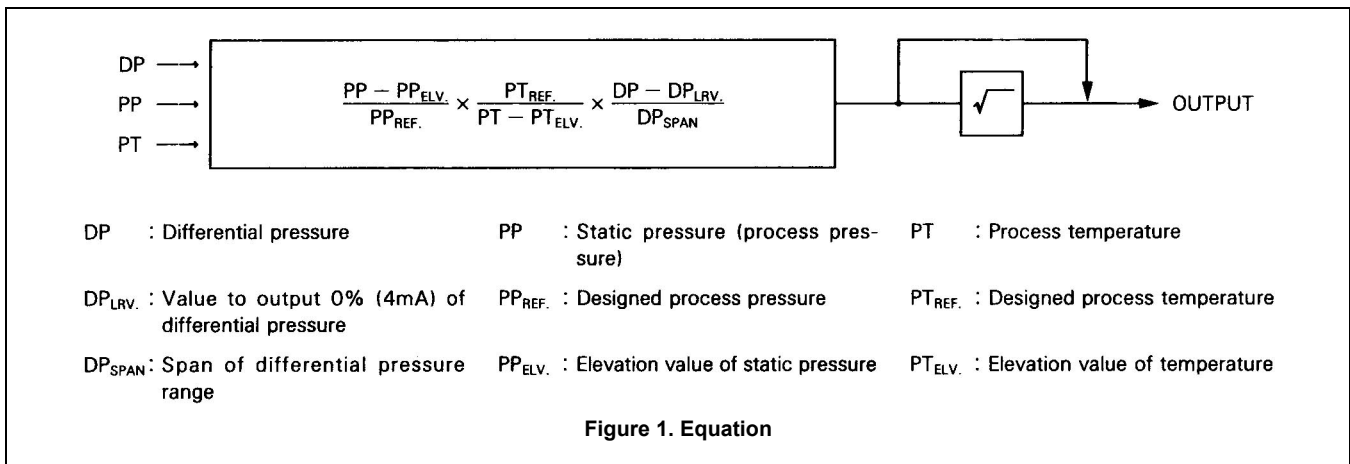

MODEL SELECTION

Basic Model No.	Selection I			Selection II	Options		Description
	Material	Fill fluid	Process Connection		I	II	
JTD720							Measuring span : 75 to 1000mmH ₂ O {0.75 to 98.1 kPa}
							Meter body cover Vent/drain plugs Wetted parts of center body
	-A						Carbon steel SUS316 Diaphragm: SUS316L Others : SUS316
	-E						SUSF316 SUS316 Diaphragm: SUS316L Others : SUS316
		1					Regular type (Silicone oil)
		2					For oxygen (Fluorine oil) service
			Q				Rc ½
			R				½NPT internal thread
			S				Rc ¼
			T				¼NPT internal thread
				-00000			No selection
					-X		No option
					-M		Built-in indicating meter (0 to 100% linear and 0 to 10 √ double scales)
					-W		SUS304 bolts and nuts material
					-A		Corrosion-resistant finish
					-B		Corrosion-proof finish
					-D		Corrosion-resistant finish, silver paint
					-N		½NPT internal-thread electrical conduit connection (Unavailable combination with 1 of Options)
					-K		No oil finish
					-Q		Two cable adaptors with flameproof packing
					-J		Long vent/drain plug
					-1		JIS special flameproof structure (Unavailable combination with N of Options)
					-XX		No options
					-A5		Upward output burnout at abnormal condition
					-D1		Built-in digital indicating meter
					-E1		w/Elbow

DIMENSIONS

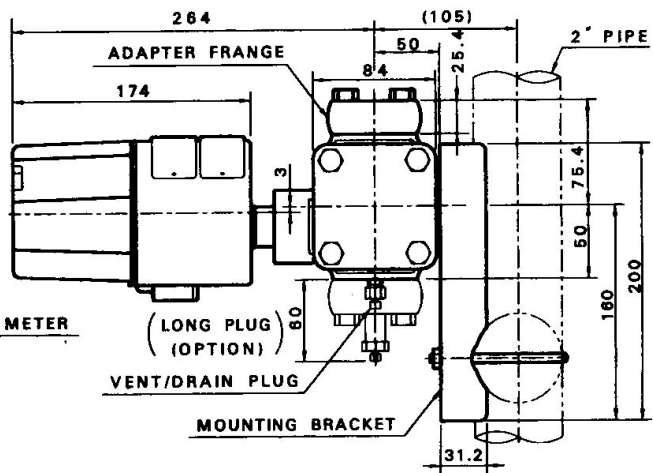
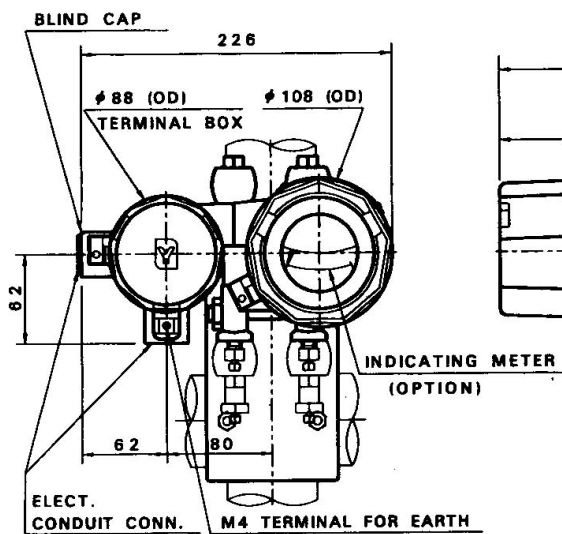
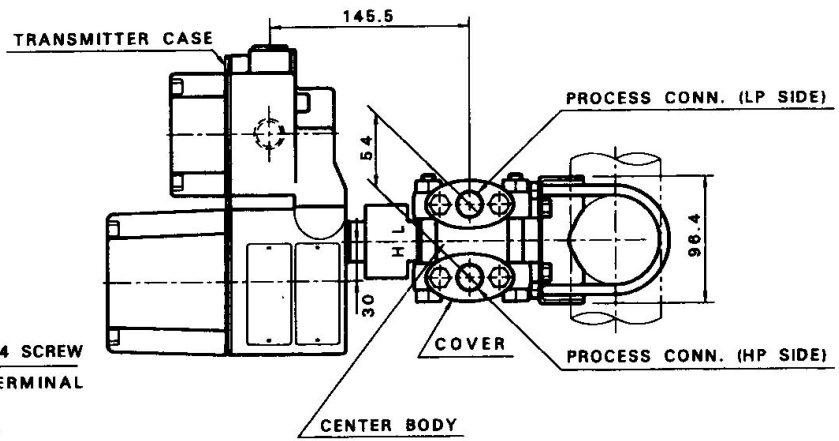
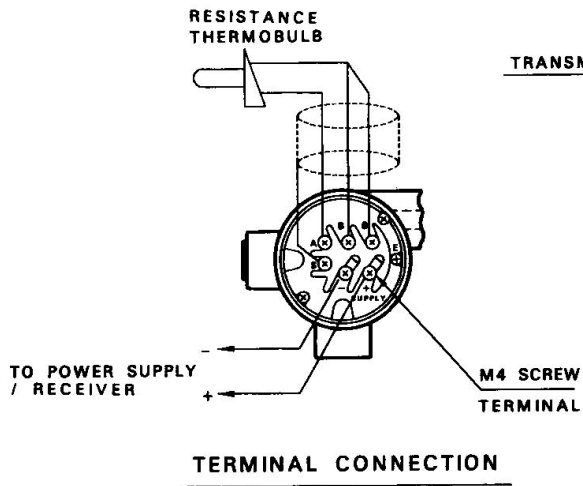

- Note:**
- 1) The process connection can be made in any of two positions of top or bottom. When connection is changed, replace the vent/drain plug.
 - 2) This transmitter can be mounted in various ways using the holes of the mounting bracket. (The above drawing shows an example of typical mounting.)
 - 3) Mount the transmitter vertically.

YAMATAKE**Savemation***Saving through Automation*

Yamatake Corporation

Totate International Building
2-12-19 Shibuya
Shibuya-ku, Tokyo 150-8316
Tel : 81-3-3486-2216
Fax : 81-3-3486-2503

Yamatake-SIC Control Systems Co., Ltd.
Shanghai Yamatake Jinshan Control Instruments Co., Ltd.
Yamatake Korea Co., Ltd.
Yamatake Taiwan Co., Ltd.
Yamatake (Thailand) Co., Ltd.
Yamatake Philippines, Inc.
PT. Yamatake Berca Indonesia
Yamatake Controls Singapore Pte. Ltd.
Yamatake Automation (M) Sdn. Bhd
YCV Corporation
SICAL Yamatake Ltd.

: China 86-10-6510-2505
: China 86-21-6428-8661
: Korea 82-2-785-0280 to 2
: Taiwan 886-2-2501-1066
: Thailand 66-2-210-0900 to 7
: Philippines 63-2-817-6452
: Indonesia 62-21-230-5538
: Singapore 65-778-5966
: Malaysia 60-3-706-5740
: USA 1-602-548-1800
: India 91-44-375-0801

Yamatake Industrial Systems Co., Ltd.

This has been printed on recycled paper.

<http://www.yamatake.co.jp/>