

## ST3000 ACE Smart Transmitter

### JTD Series of Differential Pressure Transmitters Model JTD910A/920A/930A/960A/921A/931A/961A

#### **OVERVIEW**

The ST3000 ACE Smart Transmitter is a microprocessor-based smart transmitter that features high performance and excellent stability. Capable of measuring gas, liquid, and vapor flow rates, pressures, and liquid levels, it transmits 4 to 20 mA DC analog and digital signals according to the measured differential pressure.

It can also execute two-way communications between the CommPad (Smart communicator), or the SFC (Smart Communicator), and via DE protocol with the TDCS3000 or 3000<sup>X</sup>, or Advanced-PS, and a database, thus facilitating self-diagnosis, range resetting, and automatic zero adjustment.

Refer to No. SS2-DST10F-0100 for FOUNDATION<sup>TM</sup> Fieldbus specification.

#### **FEATURES**

##### **Excellent stability and high performance**

- Long-term stability has been proven in 500,000 installations worldwide.
- Unique characterization and composite semiconductor sensors realize excellent temperature and static pressure characteristics.

##### **Wide measuring range (rangeability)**

- A wide measuring range is available from a single model. This feature is highly effective in taking measurements over a wide range and reducing the need for reserve units. The measuring range of the model JTD920A, for example, is 0.75 to 100 kPa (range ability = 1: 135).

##### **A diverse lineup**

- A wide range of models is available to meet user requirements. They include micro-differential pressure, standard differential pressure, high differential pressure, standard differential pressure/high static pressure, and



high differential pressure/high static pressure models.

- A wide variety of corrosion-resistant materials for wetted parts is also available.

##### **Multi protocol communication**

- Either analog output (4 to 20 mA DC), analog FSK output (4 to 20 mA DC) or digital output (DE protocol), FOUNDATION<sup>TM</sup> Fieldbus protocol is possible.
- Two-way communication using digital output facilitates self-diagnosis, range resetting, automatic zero adjustment, and other operations.

##### **Full after-sales service program**

- A wide variety of specialized replacement kits is provided to meet customers' needs when replacing Yamatake transmitters or transmitters from other companies.
- From product delivery to replacement, we will service all your needs. Our nationwide service network provides all the backup you require, including trial operation support and regular maintenance.

## APPLICATION

### **Petroleum / Petrochemical / Chemical**

- For strict flow control in combination with orifice plates
- For measuring pressures and liquid levels in pipes and tanks

### **Electric power / City gas / Other utilities**

- For measurement applications that require high degrees of stability and accuracy

### **Draft range applications such as semiconductor equipment manufacturing / Clean rooms**

- For applications that require highly stable, accurate measurement

### **Pulp and paper**

- For lines that need transmitters resistant to chemical liquids, corrosive fluids and the like

### **Iron and steel / Nonferrous metal / Ceramics**

- For highly stable, accurate measurements such as furnace pressure measurement
- For lines that require stable measurement under strictly controlled (temperature, humidity, etc.) conditions

### **Machinery / Shipbuilding**

- For lines that require stable measurement under strictly controlled (temperature, humidity, etc.) conditions

## SPECIFICATIONS

### **Measuring span / Setting range / Working pressure range**

See Table 1.

### **Output / Communication**

Analog output (4 to 20 mA DC)  
 Analog FSK output (4 to 20 mA DC)  
 (Frequency shift keying signal transmission system)  
 Digital output (DE protocol)  
 Digital output (FOUNDATION™ Fieldbus protocol)

### **Supply voltage and load resistance**

10.8 to 45V DC. A load resistance of 250 Ω or more is necessary between loops. (See Figure 1)

### **Fill Fluid**

Silicone oil for general purpose models  
 Fluorine oil for oxygen and chlorine models

### **Ambient temperature range**

#### **Normal operating range**

-40 to 85°C for general purpose models

-15 to 65°C for general purpose model (JTD910A)  
 -10 to 75°C for oxygen and chlorine models  
 -20 to 70°C for models with digital indicators

#### **Operative limits**

-50 to 93°C for general purpose models  
 -40 to 70°C for general purpose model (JTD910A)  
 -40 to 80°C for oxygen and chlorine models  
 -30 to 80°C for models with digital indicators

JIS special explosion-proof models: -20 to 60°C

JIS intrinsically safe models: -10 to 60°C

### **Temperature ranges of wetted parts**

#### **Normal operating range**

-40 to 110°C for general purpose models  
 -10 to 75°C for oxygen and chlorine models

#### **Operative limits:**

-50 to 115°C for general purpose models  
 -40 to 80°C for oxygen and chlorine models

JIS special explosion-proof models: -20 to 110°C

(JTD910A: -15 to 65°C)

JIS intrinsically safe models: -10 to 100°C

(JTD910A: -15 to 65°C)

### **Ambient humidity range**

5 to 100% RH

### **Stability against supply voltage change**

± 0.005% F.S./V

### **Lightning protection**

Peak value of voltage surge: 100 kV

Peak value of current surge: 1000A

### **Dead time**

Approximately 0.4 sec.

### **Damping time constant**

Selectable from 0 to 32 sec. in ten stages

### **Waterproof / Dustproof structure**

JIS C0920 watertight: NEMA3 and 4X

JIS F8001 class 2 watertight: IEC IP67

### **Explosion-proof structure**

JIS explosion-proof models: (Exd II CT4X)

JIS intrinsically safe models: (i3aG4)

*Note) Please use the cable that can be used in the environment that maximum ambient temperature is beyond 65°C*

### **Vibration effect**

Amplitude 1.5mm / Frequency 0 to 9Hz

5m/s<sup>2</sup>(0.5G) / 9 to 60Hz

### **Impact effect**

10m/s<sup>2</sup>(1G)

**Table 1 Measuring span, setting range, and working pressure range**

(for negative pressure in the working pressure range, see Figure2, Figure 3, Figure 4 and Figure 5.)

Model	Measuring span	Setting range	Working pressure range
JTD910A	0.1 to 2 kPa {10 to 200 mmH <sub>2</sub> O}	-1 to 1 kPa {-100 to 100 mmH <sub>2</sub> O}	-70 to 210 kPaG {-0.7 to 2.1 kgf/cm <sup>2</sup> }
JTD920A	0.75 to 100 kPa {75 to 10160 mm H <sub>2</sub> O}	-100 to 100 kPa {-10160 to 10160 mmH <sub>2</sub> O}	2.0 kPa abs. to 14 MPa *1 *2 {15 mmHg abs. to 140 kgf/cm <sup>2</sup> }
JTD930A	35 to 700 kPa {0.35 to 7 kgf/cm <sup>2</sup> }	-100 to 700 kPa {-1 to 7 kgf/cm <sup>2</sup> }	
JTD960A	0.25 to 14 MPa {2.5 to 140 kgf/cm <sup>2</sup> }	-0.1 to 14 MPa {-1 to 140 kgf/cm <sup>2</sup> }	2.0 kPa abs. to 14 MPa *2 {15 mmHg abs. to 140 kgf/cm <sup>2</sup> }
JTD921A	2.5 to 100 kPa {250 to 10160 mmH <sub>2</sub> O}	-100 to 100 kPa {-10160 to 10160 mmH <sub>2</sub> O}	2.0 kPa abs. to 42 Mpa *3 {15 mmHg abs. to 420 kgf/cm <sup>2</sup> }
JTD931A	35 to 700 kPa {0.35 to 7 kgf/cm <sup>2</sup> }	-100 to 700 kPa {-1 to 7 kgf/cm <sup>2</sup> }	
JTD961A	0.25 to 14 MPa {0.25 to 140 kgf/cm <sup>2</sup> }	-0.1 to 14 MPa {-1 to 140 kgf/cm <sup>2</sup> }	

Note) \*1: With PVC wetted parts, the maximum working pressure is 1.5 MPa {15 kgf/cm<sup>2</sup>}  
 \*2: With SUS304 bolts and nuts, the maximum working pressure is 10 MPa {100 kgf/cm<sup>2</sup>}  
 \*3: With SUS304 bolts and nuts, the maximum working pressure is 23 MPa {230 kgf/cm<sup>2</sup>}  
 \*4: JTD910A is high sensitivity. So that shall not be receiving the mounting position of the radiant heat of the wind effect.

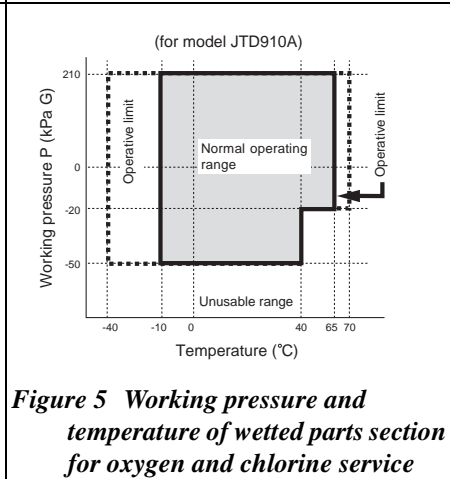
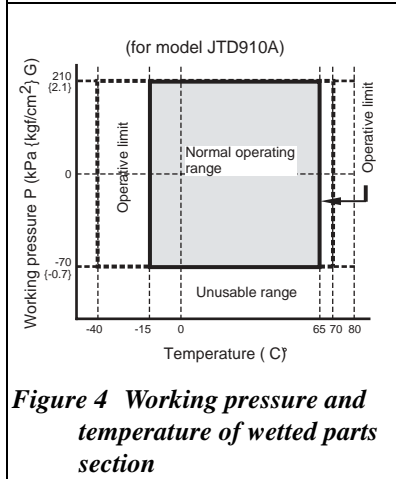
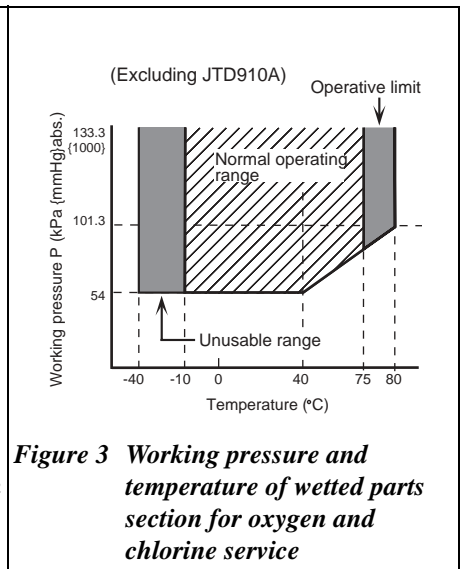
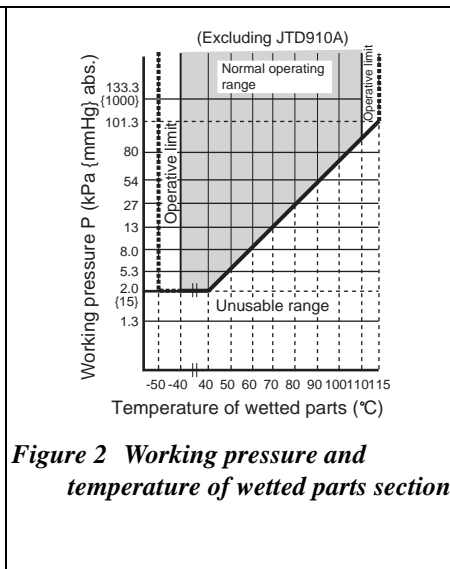
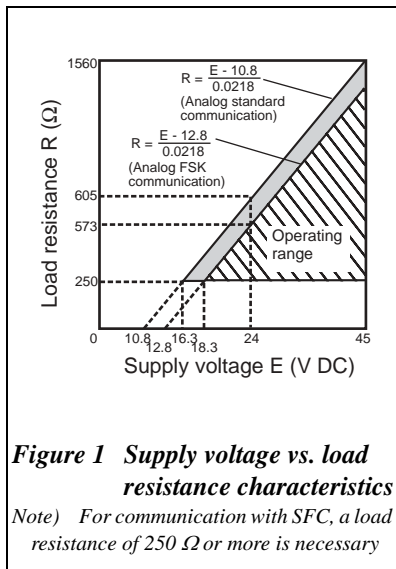

**Process pipe connection**

Rc1/2, 1/2NPT internal thread and Rc1/4, 1/4NPT internal thread

**Electrical conduit connection**

G1/2 internal thread and 1/2NPT internal thread

**Materials**

Center body: SUS316

Transmitter case: Aluminum alloy

**Wetted parts materials****Meter body cover**

SCS14A(SUS316),SUSF316, PVC

**Wetted parts of center body**

SUS316 (Diaphragm: SUS316L),  
ASTM B575 (Hastelloy C-276 equivalent),  
tantalum, etc.

**Vents and plugs**

SUS316, PVC

**Gaskets for wetted parts**

FEP (Teflon)

**Bolts and nuts material (for fastening meter body cover)**

Carbon steel (SNB7), SUS304, SUS630

**Finish**

Housing: light beige (Munsell 4Y7.2/1.3)

Cap: dark beige (Munsell 10YR4.7/0.5)

**Corrosion-resistant finish****Standard**

Corrosion-resistant paint (Baked acrylic paint)

**Corrosion-resistant finish**

Corrosion-resistant paint (Baked acrylic paint),  
fungus-proof finish

**Corrosion-proof finish**

Corrosion-proof paint (Baked epoxy paint), fungus-proof finish

**Corrosion-resistant finish (silver paint)**

Transmitter case is silver-coated in addition to the above corrosion-resistant finish.

**Built-in indicating meter**

The digital LCD indicator (optional) indicates actual flow rates (in SI units) and can be set freely between -19999 and 19999 (4.5 digits). For actual calibration, specify the following items when placing your order:

- Actual calibration range
- Actual calibration unit
- Proportional representation and instructions about square-root extraction

Various kinds of data can be set using the SFC smart communicator (Ver. 7.1 or later).

**Burnout feature**

Choice of three states at abnormal condition:

Burnout of output values: none

upper limit: 20.8mA (105%) or more

lower limit: 3.8mA (-1.25%) or less

**Grounding**

Grounding resistance 100Ω max.

**Installation**

Can be installed on a 2-inch horizontal or vertical pipe (can be directly mounted on a process pipe)

**Weight**

Approx. 4.4 kg (Model JTD920A)

**OPTIONAL SPECIFICATIONS****Adaptors for anticorrosion materials**

These are adaptor flanges to connect 82 mm pipes made of anticorrosion materials (excluding ASTM B575 (Hastelloy C-276 equivalent)) to 54 mm general-purpose pipes.

**External zero adjustment function**

The transmitter can be easily zero-adjusted in the field with a flat-blade screwdriver.

**Additional lightning protection**

It is possible to achieve a lightning protection performance of 200 kV, 2000A, twice the standard performance (100 kV, 1000A). This is advisable when the transmitter is to be used in lightning-prone areas such as mountains, hills or wherever high-performance lightning protection is required.

**Long vent drain**

A longer (58 mm) drain than the standard (24 mm) can be used for maintenance, process, and safety reasons.

**Steam block**

A block with steam piping can be attached to the initial process section of the transmitter to deal with process fluids or steam that tend to coagulate or condense at low temperatures.

**Working pressure (Steam block)**

5 MPa {50 kgf/cm<sup>2</sup>} max.

(Must not exceed the working pressure range)

**Working temperature (Steam block)**

250°C max.

(The temperature of the wetted parts of the transmitter must not exceed the temperature range of the wetted parts.)

**Elbow**

This is an adaptor for changing the electrical conduit connection port from the horizontal to the vertical direction, if required by wiring conditions in the field. One or two elbows may be used as needed.

**Water free treatment (including oil free treatment)**

The transmitter is shipped with dry and oil-free wetted parts.

**Oil free treatment**

The transmitter is shipped with oil-free wetted parts.

**Electric power specification**

This specification applies to where stringent quality control is required, such as in the electrical power and city gas industries.

**Special burnout (3.2 mA)**

The burnout output value (in the lower-limit direction) under abnormal conditions shall be 3.2 mA (-5%) or less.

**Output saturation**

The output saturation point can be set within the following ranges.

$$12\text{mA}(50\%) \leq \text{output upper limit} \leq 20.8\text{mA}(105\%)$$

$$3.2\text{mA}(-5\%) \leq \text{output lower limit} \leq 12\text{mA}(50\%)$$

*Note) As HART communication type, the lower limit of output saturation becomes 3.8mA(-1.25%).*

**Test report**

The test report indicates the results of appearance, I/O characteristics, insulation resistance, and breakdown voltage tests.

**Material certificate**

The material certificate shows the chemical composition, heat-treatment conditions, and mechanical properties of the materials used for the wetted parts. The transmitter can be easily zero-adjusted in the field with a flat-blade screwdriver.

**Strength calculation sheet**

The strength calculation sheet indicates the strength of the meter body cover, flanges, bolts, etc.

**Withstand pressure and air tight test (for general purposes)**

The withstand pressure and air tight test result sheet shows the results of a pressure resistance test (under water pressure for 10 minutes) and a gas-tightness test (using N<sub>2</sub> gas for 10 minutes) performed on the wetted parts.

**Traceability certificate**

This certificate consists of three parts: the transmitter's measurement control system configuration diagram, a calibration certificate, and a test report.

**Conformance to non-SI units**

We deliver transmitters set to any non-SI unit you specify.

## **Transmitter handling notes**

To get the most from the performance this transmitter can offer, please use it properly noting the points mentioned below. Before using it, please read the Instruction Manual.

### **Transmitter installation notes**

#### **⚠ WARNING**

- When installing the transmitter, ensure that gaskets do not protrude from connecting points into the process (such as adapter flange connection points and connecting pipes and flanges). Gasket protrusion may result in leaks and output errors.
- Do not use the transmitter outside its defined pressure, temperature, and connection specifications. A serious accident may otherwise occur due to damage and leaks.
- When performing wiring work in explosion-proof areas, follow the work method specified in the explosion-proof guidelines. In addition, when the wiring for an explosionproof product is a pull-in pressure-resistant packing cable, be sure to use a pressure-resistant packing-cable adapter certified by Yamatake Corporation.
- Be sure to use the cable which allowable temperature is more than 65°C.

#### **⚠ CAUTION**

- After installing the transmitter, do not stand on it. Using it as a foothold could cause it to collapse and cause physical injury.
- Be careful not to hit the glass indicator with tools etc. This could break the glass and cause injury.
- The transmitter is heavy. Wear safety shoes and take care when installing it.

### **Wiring notes**

#### **⚠ WARNING**

- To avoid shocks, do not perform electrical wiring work with wet hands or with live wires.

#### **⚠ CAUTION**

- Do wiring work properly in conformance with the specifications. Wiring mistakes may result in malfunction or irreparable damage to the instrument.
- Use a power supply that conforms to the specifications. Use of an improper power supply may result in malfunction or irreparable damage to the instrument.

**PERFORMANCE**

Shown for each performance (accuracy/ temperature characteristics/ static pressure effect) are absolute value of the upper limit (URV)<sup>\*1</sup> and the lower limit (LRV)<sup>\*2</sup> of the calibration range or the percentage ratio of the maximum value of the span to  $\chi$ .

**Model JTD910A (material for wetted parts: SUS316)**

Accuracy	<b>Linear output:</b>	$\pm\left(0.15 + 0.15 \times \frac{1.0}{\chi}\right) \%$	$(\chi:kPa)$
	<b>Square-root output:</b>	When output is 50 to 100%: same as linear output When output is 7.1 to 50%: linear output $\times \frac{50}{\text{square-root output}} \%$ When output is less than 7.1%: dropout	
Temperature characteristics (Shift from the set range) Change of 30°C	<b>Zero shift:</b>	$\pm\left(0.15 + 0.35 \times \frac{1.0}{\chi}\right) \%$	$(\chi:kPa)$
	<b>Combined shift:</b> (including zero and span shift)	$\pm\left(0.2 + 0.6 \times \frac{1.0}{\chi}\right) \%$	$(\chi:kPa)$
Static pressure effect (Shift with respect to setting range) Change of 70 kPa {0.7 kgf/cm <sup>2</sup> }	<b>Zero shift:</b>	$\pm 0.45\%$	$(\chi \geq 1.0 kPa \{100 mmH_2O\})$
	<b>Combined shift:</b> (including zero and span shift)	$\pm\left(0.45 \times \frac{1.0}{\chi}\right) \%$ $\pm 0.5\%$ $\pm\left(0.5 \times \frac{1.0}{\chi}\right) \%$	$(\chi < 1.0 kPa \{100 mmH_2O\})$ $(\chi \geq 1.0 kPa \{100 mmH_2O\})$ $(\chi < 1.0 kPa \{100 mmH_2O\})$

**Model JTD920A / 921A (material for wetted parts: SUS316)**

Accuracy <sup>*3</sup>	<b>Linear output:</b>	$\pm 0.1\%$	$(\chi \geq 5.0 kPa \{500 mmH_2O\})$
	<b>Square-root output:</b>	$\pm\left(0.025 + 0.075 \times \frac{5.0}{\chi}\right) \%$ When output is 50 to 100%: same as linear output When output is 7.1 to 50%: linear output $\times \frac{50}{\text{square-root output}} \%$ When output is less than 7.1%: dropout	$(\chi < 5.0 kPa \{500 mmH_2O\})$
Temperature characteristics (Shift from the set range) <sup>*3</sup> Change of 30°C	<b>Zero shift:</b>	$\pm\left(0.14 + 0.17 \times \frac{12.5}{\chi}\right) \%$	$(\chi:kPa)$
	<b>Combined shift:</b> (including zero and span shift)	$\pm 0.44\%$ $\pm\left(0.19 + 0.25 \times \frac{12.5}{\chi}\right) \%$	$(\chi \geq 12.5 kPa \{1250 mmH_2O\})$ $(\chi < 12.5 kPa \{1250 mmH_2O\})$
Static pressure effect (Shift with respect to setting range) <sup>*3</sup> Change of 7 MPa {70 kgf/cm <sup>2</sup> }	<b>Zero shift:</b>	$\pm 0.18 \%$ $\pm\left(0.18 \times \frac{20.0}{\chi}\right) \%$	$(\chi \geq 20.0 kPa \{2000 mmH_2O\})$ $(\chi < 20.0 kPa \{2000 mmH_2O\})$
	<b>Combined shift:</b> (including zero and span shift)	$\pm 0.33 \%$ $\pm\left(0.33 \times \frac{20.0}{\chi}\right) \%$	$(\chi \geq 20.0 kPa \{2000 mmH_2O\})$ $(\chi < 20.0 kPa \{2000 mmH_2O\})$

**Model JTD930A / 931A (material for wetted parts: SUS316)**

Accuracy <sup>*3</sup>	<b>Linear output:</b>	$\pm 0.1\%$	$(\chi \geq 140 kPa \{1.4 kgf/cm^2\})$
	<b>Square-root output:</b>	$\pm\left(0.025 + 0.075 \times \frac{140}{\chi}\right) \%$ When output is 50 to 100%: same as linear output When output is 7.1 to 50%: linear output $\times \frac{50}{\text{square-root output}} \%$ When output is less than 7.1%: dropout	$(\chi < 140 kPa \{1.4 kgf/cm^2\})$
Temperature characteristics (Shift from the set range) <sup>*3</sup> Change of 30°C	<b>Zero shift:</b>	$\pm\left(0.14 + 0.17 \times \frac{12.5}{\chi}\right) \%$	$(\chi:kPa)$
	<b>Combined shift:</b> (including zero and span shift)	$\pm 0.44\%$ $\pm\left(0.19 + 0.25 \times \frac{12.5}{\chi}\right) \%$	$(\chi \geq 12.5 kPa \{1250 mmH_2O\})$ $(\chi < 12.5 kPa \{1250 mmH_2O\})$

Static pressure effect (Shift with respect to setting range) <sup>*3</sup> Change of 7 MPa {70 kgf/cm <sup>2</sup> }	Zero shift:	$\pm\left(0.18 \times \frac{700}{\chi}\right) \%$	( $\chi:kPa$ )
	Combined shift: (including zero and span shift)	$\pm\left(0.33 \times \frac{700}{\chi}\right) \%$	( $\chi:kPa$ )

### Model JTD960A / 961A

Material for wetted parts: SUS316

Accuracy <sup>*3</sup>	Linear output:	$\pm 0.15\%$	( $\chi \geq 3.5 MPa \{35 kgf/cm^2\}$ )
		$\pm\left(0.1 + 0.05 \times \frac{3.5}{\chi}\right) \%$	( $\chi < 3.5 MPa \{35 kgf/cm^2\}$ )
Temperature characteristics (Shift from the set range) <sup>*3</sup> Change of 55°C	Square-root output:	When output is 50 to 100%: same as linear output	
		When output is 7.1 to 50%: linear output $\times \frac{50}{\text{square-root output}} \%$	
		When output is less than 7.1%: dropout	
Static pressure effect (Shift with respect to setting range) <sup>*3</sup> Change of 7 MPa {70 kgf/cm <sup>2</sup> }	Zero shift:	$\pm\left(0.14 + 0.16 \times \frac{3.5}{\chi}\right) \%$	( $\chi:MPa$ )
	Combined shift: (including zero and span shift)	$\pm 0.44\%$	( $\chi \geq 3.5 MPa \{35 kgf/cm^2\}$ )
		$\pm\left(0.19 + 0.25 \times \frac{3.5}{\chi}\right) \%$	( $\chi < 3.5 MPa \{35 kgf/cm^2\}$ )
Static pressure effect (Shift with respect to setting range) <sup>*3</sup> Change of 7 MPa {70 kgf/cm <sup>2</sup> }	Zero shift:	$\pm\left(0.03 + 0.17 \times \frac{7}{\chi}\right) \%$	( $\chi > 7 MPa \{70 kgf/cm^2\}$ )
	Combined shift: (including zero and span shift)	$\pm 0.4\%$	( $\chi \leq 7 MPa \{70 kgf/cm^2\}$ )
		$\pm\left(0.03 + 0.37 \times \frac{7}{\chi}\right) \%$	( $\chi \leq 7 MPa \{70 kgf/cm^2\}$ )

T: Ambient temperature (°C)

### Model JTD920A

Material for wetted parts: ASTM B575 (Hastelloy C-276 equivalent), Tantalum

Accuracy <sup>*3</sup>	Linear output:	$\pm 0.2\%$	( $\chi \geq 5.0 kPa \{500 mmH_2O\}$ )
		$\pm\left(0.125 + 0.075 \times \frac{5.0}{\chi}\right) \%$	( $\chi < 5.0 kPa \{500 mmH_2O\}$ )
Temperature characteristics (Shift from the set range) <sup>*3</sup> Change of 30°C (Range from -5 to 55°C)	Square-root output:	When output is 50 to 100%: same as linear output	
		When output is 7.1 to 50%: linear output $\times \frac{50}{\text{square-root output}} \%$	
		When output is less than 7.1%: dropout	
Static pressure effect (Shift with respect to setting range) <sup>*3</sup> Change of 7 MPa {70 kgf/cm <sup>2</sup> }	Zero shift:	$\pm\left(0.15 + 0.6 \times \frac{20.0}{\chi}\right) \%$	( $\chi:kPa$ )
	Combined shift: (including zero and span shift)	$\pm\left(0.55 + 0.65 \times \frac{20.0}{\chi}\right) \%$	( $\chi:kPa$ )
Static pressure effect (Shift with respect to setting range) <sup>*3</sup> Change of 7 MPa {70 kgf/cm <sup>2</sup> }	Zero shift:	$\pm 0.66 \%$	( $\chi \geq 20.0 kPa \{2000 mmH_2O\}$ )
		$\pm\left(0.66 \times \frac{20.0}{\chi}\right) \%$	( $\chi < 20.0 kPa \{2000 mmH_2O\}$ )
	Combined shift: (including zero and span shift)	$\pm 1.0 \%$	( $\chi \geq 20.0 kPa \{2000 mmH_2O\}$ )
		$\pm\left(1.0 \times \frac{20.0}{\chi}\right) \%$	( $\chi < 20.0 kPa \{2000 mmH_2O\}$ )

Note) \*1: URV denotes the value for 100% (20 mA DC) output.

\*2: LRV denotes value for 0% (4 mA DC) output

\*3: Within a range of URV  $\geq 0$  and LRV  $\geq 0$

\*4: Hastelloy C-276 equivalent material.

**Model JTD930A**

Material for wetted parts: ASTM B575 (Hastelloy C-276 equivalent), Tantalum, SUS316L

Accuracy <sup>*3</sup>	<b>Linear output:</b>	$\pm 0.2\%$ (For $\chi \geq 140 \text{ kPa} \{1.4 \text{ kgf/cm}^2\}$ )
		$\pm \left(0.125 + 0.075 \times \frac{140}{\chi}\right) \%$ (For $\chi < 140 \text{ kPa} \{1.4 \text{ kgf/cm}^2\}$ )
	<b>Square-root output:</b>	When output is 50 to 100%: same as linear output
		When output is 7.1 to 50%: linear output $\times \frac{50}{\text{square-root output}} \%$ When output is less than 7.1%: dropout
Temperature characteristics (Shift from the set range) <sup>*3</sup> Change of 30°C (Range from -5 to 55°C)	<b>Zero shift:</b>	$\pm \left(0.15 + 0.6 \times \frac{210}{\chi}\right) \%$ ( $\chi: \text{kPa}$ )
	<b>Combined shift:</b> (including zero and span shift)	$\pm 1.2\%$ (For $\chi \geq 210 \text{ kPa} \{2.1 \text{ kgf/cm}^2\}$ ) $\pm \left(0.55 + 0.65 \times \frac{210}{x}\right) \%$ (For $\chi < 210 \text{ kPa} \{2.1 \text{ kgf/cm}^2\}$ )
Static pressure effect (Shift with respect to setting range) <sup>*3</sup> Change of 7 MPa {70 kgf/cm <sup>2</sup> }	<b>Zero shift:</b>	$\pm \left(0.03 + 0.295 \times \frac{700}{\chi}\right) \%$ ( $\chi: \text{kPa}$ )
	<b>Combined shift:</b> (including zero and span shift)	$\pm \left(0.03 + 0.495 \times \frac{700}{\chi}\right) \%$ ( $\chi: \text{kPa}$ )

**Model JTD960A**

Material for wetted parts: ASTM B575 (Hastelloy C-276 equivalent), Tantalum, SUS316L

Accuracy <sup>*3</sup>	<b>Linear output:</b>	$\pm 0.3\%$ (For $\chi \geq 3.5 \text{ MPa} \{35 \text{ kgf/cm}^2\}$ )
		$\pm \left(0.25 + 0.05 \times \frac{3.5}{\chi}\right) \%$ (For $\chi < 3.5 \text{ MPa} \{35 \text{ kgf/cm}^2\}$ )
	<b>Square-root output:</b>	When output is 50 to 100%: same as linear output
		When output is 7.1 to 50%: linear output $\times \frac{50}{\text{square-root output}} \%$ When output is less than 7.1%: dropout
Temperature characteristics (Shift from the set range) <sup>*3</sup> Change of 30°C (Range from -5 to 55°C)	<b>Zero shift:</b>	$\pm \left(0.15 + 0.6 \times \frac{3.5}{\chi}\right) \%$ ( $\chi: \text{kPa}$ )
	<b>Combined shift:</b> (including zero and span shift)	$\pm 1.2\%$ (For $\chi \geq 3.5 \text{ MPa} \{35 \text{ kgf/cm}^2\}$ ) $\pm \left(0.55 + 0.65 \times \frac{3.5}{x}\right) \%$ (For $\chi < 3.5 \text{ MPa} \{35 \text{ kgf/cm}^2\}$ )
Static pressure effect (Shift with respect to setting range) <sup>*3</sup> Change of 7 MPa {70 kgf/cm <sup>2</sup> }	<b>Zero shift:</b>	$\pm \left(0.03 + 0.295 \times \frac{7}{\chi}\right) \%$ ( $\chi: \text{kPa}$ )
	<b>Combined shift:</b> (including zero and span shift)	$\pm 0.525\%$ (For $\chi \geq 7 \text{ MPa} \{70 \text{ kgf/cm}^2\}$ ) $\pm \left(0.03 + 0.495 \times \frac{7}{\chi}\right) \%$ (For $\chi < 7 \text{ MPa} \{70 \text{ kgf/cm}^2\}$ )

Note) \*1: URV denotes the value for 100% (20 mA DC) output.

\*2: LRV denotes value for 0% (4 mA DC) output

\*3: Within a range of  $URV \geq 0$  and  $LRV \geq 0$ 

\*4: Hastelloy C-276 equivalent material.

**MODEL SELECTIONS**

**Model JTD910A - Lowest differential pressure - Regular service**

Basic model no.      Selections      Options 1      Options 2 (Options 2: Refer to page 17)

- 
  I  II  III  IV  V - 
  VI  VII  VIII  IX  X -

Model	Pressure range / style		Service (Fill fluid)	Process connection
JTD910A	0.1 to 2 kPa (10 to 200 mmH <sub>2</sub> O)	Lowest differential pressure	Regular service (Silicon oil)	Rc1/2, 1/2NPT, Rc1/4, NPT1/4

Measuring span		0.1 to 2.0 kPa (10 to 200 mmH <sub>2</sub> O)		JTD910A	Basic model no. Selections					Options 1													
<b>Selections</b>																							
I	Output	4 to 20 mA			1																		
		4 to 20 mA (Analog FSK communication) *1			2																		
		Digital output (DE protocol) *2			3																		
		Digital output (FOUNDATION Fieldbus protocol) *41			4																		
		4 to 20 mA (HART protocol) *43			5																		
II	Material	Meterbody cover	Vent / drain plugs	Wetted parts of center body																			
		SUSF316	SUS316	SUS316	E																		
III	Fill fluid	Regular type (Silicon oil)			1																		
IV	Process connection	Rc1/2, top connection			A																		
		Rc1/2, bottom connection			B																		
		1/2NPT internal thread, top connection			F																		
		1/2NPT internal thread, bottom connection			G																		
		Rc1/4, top connection			L																		
		Rc1/4, bottom connection			M																		
		1/4NPT internal thread, top connection			R																		
		1/4NPT internal thread, bottom connection			S																		
V	Bolt / nut	SUS304			2																		
<b>Options 1</b>																							
VI	Electrical connection / explosion-proof	G1/2, watertight			X																		
		G1/2, JIS Flameproof with 1 pc. of cable gland attached			2																		
		G1/2, JIS Flameproof with 2 pcs. of cable gland attached			3																		
		G1/2, Intrinsically safe *3			6																		
		1/2NPT, watertight			A																		
VII	Built-in indicating smart meter	None			X																		
		0 to 100% linear scales *1			1																		
		Engineering unit scales *1			2																		
VIII	Finish	Standard			X																		
		Corrosion-resistant			A																		
		Corrosion-proof			B																		
		Corrosion-resistant (Silver coating)			D																		
IX	Burnout feature	None *2			X																		
		Upper limit of output at abnormal condition *5			U																		
		Lower limit of output at abnormal condition *5			D																		
X	Mounting bracket	None			X																		
		Carbon steel			1																		
		SUS304			2																		

- Note 1: Range should be informed to IBQ/Factory at purchase order. Digital output (DE protocol) should be selected with upper/lower direction of burn out feature.
- 2: Digital output (DE protocol) can not be combined with an external zero adjustment function.
- 3: Analog FSK communication can not be combined with JIS intrinsically safe.
- 41: Code LI must be selected for OPTION2.
- 42: Burnout function can not be combined with FOUNDATION™ Fieldbus.
- 43: HART communication can not be combined with special burnout (3.2mA) or JIS Intrinsically safe.

**Model JTD920A / JTD930A / JTD960A - Regular service**

Basic model no.      Selections      Options 1      Options 2 (Options 2: Refer to page 17)

\_\_\_\_\_ - [ I | II | III | IV | V ] - [ VI | VII | VIII | IX | X ] - \_\_\_\_\_

Model	Pressure range / style	Service (Fill fluid)	Process connection
JTD920A	0.75 to 100 kPa (75 to 10160 mmH <sub>2</sub> O)	Medium differential pressure	Regular service (Silicon oil) Rc1/2, 1/2NPT, Rc1/4, NPT1/4
JTD930A	35 to 700 kPa (0.35 to 7 kgf/cm <sup>2</sup> )	High differential pressure	
JTD960A	0.25 to 14 MPa (2.5 to 140 kgf/cm <sup>2</sup> )	Super high differential pressure	

		Basic model no.	Selections	Options-1
Measuring span	0.75 to 100 kPa (75 to 10160 mmH <sub>2</sub> O)	JTD920A		
	35 to 700 kPa (0.35 to 7 kgf/cm <sup>2</sup> )	JTD930A		
	0.25 to 14 MPa (2.5 to 140 kgf/cm <sup>2</sup> )	JTD960A		
I Output	4 to 20 mA		1	
	4 to 20 mA (Analog FSK communication) *3		2	
	Digital output (DE protocol) *2		3	
	Digital output (FOUNDATION Fieldbus protocol) *41		4	
	4 to 20 mA (HART protocol) *43		5	
II Material	Meterbody cover	Vent / drain plugs	Wetted parts of center body	
	SCS14A *32	SUS316	SUS316	E
	SCS14A *32	SUS316	ASTM B575 **	F
	*5 SUSF316	SUS316	Tantalum	H
	*5 SUSF316	SUS316	SUS316L	K
	*4, 5, 6, 10 PVC	PVC	Tantalum	P
III Fill fluid	Regular type (Silicon oil)			1
IV Process connection	Rc1/2, top connection			A
	Rc1/2, bottom connection			B
	1/2NPT internal thread, top connection			F
	1/2NPT internal thread, bottom connection			G
	Rc1/4, top connection			L
	Rc1/4, bottom connection			M
	1/4NPT internal thread, top connection			R
	1/4NPT internal thread, bottom connection			S
V Bolt / nut	Carbon steel			1
	SUS304			2
	SUS630			3
<b>Option 1</b>				
VI Electrical connection / explosion-proof	G1/2, watertight			X
	G1/2, JIS Flameproof with 1 pc. of cable gland attached			2
	G1/2, JIS Flameproof with 2 pcs. of cable gland attached			3
	G1/2, Intrinsically safe *3			6
	1/2NPT, watertight			A
VII Built-in indicating smart meter	None			X
	0 to 100% linear scales *1			1
	Engineering unit scales *1			2
VIII Finish	Standard			X
	Corrosion-resistant			A
	Corrosion-proof			B
	Corrosion-resistant (Silver coating)			D
IX Burnout feature	None *2			X
	Upper limit of output at abnormal condition			U
	Lower limit of output at abnormal condition			D
X Mounting bracket	None			X
	Carbon steel			1
	SUS304			2

- Note 1: Range should be informed to IBQ/Factory at purchase order. Digital output (DE protocol) should be selected with upper/lower direction of burn out feature.
- 2: Digital output (DE protocol) can not be combined with an external zero adjustment function.
- 3: Analog FSK Communication can not be combined with JIS intrinsically safe.
- 4: JTD960A is not available for cover material PVC.
- 5: The pitch is 82mm. To change the pitch to 54mm (standard pitch), should be selected adapter flange ("A1" of Option 2).
- 6: When meterbody cover material is PVC, option 2 should be selected "V" as bolt/nut SUS304.
- 9: This can be selected for the meterbody cover if the process fluid contains hydro-carbon or H2S which used for Refinery/Petrochemical. When you selected this, contact to IBQ/Factory.
- 10: When meterbody cover material is PVC, manifold valve (model MVG) and/or Integral orifice (model KEE) can not be combined with.
- 32: SCS14A (equivalent to SUS316) or SUSF316
- 41: Code L1 must be selected for OPTION2.
- 42: Burnout function can not be combined with FOUNDATION™ Fieldbus.
- 43: HART communication can not be combined with special burnout (3.2mA) or JIS Intrinsically safe.
- \*\* ASTM B575: Hastelloy C-276 equivalent.

**Model JTD921A / JTD931A / JTD961A - Regular service**

Basic model no.      Selections      Options 1      Options 2 (Options 2: Refer to page 17)

- 
 

I	II	III	IV	V
---	----	-----	----	---

 - 
 

VI	VII	VIII	IX	X
----	-----	------	----	---

 -

Model	Pressure range / style	Service (Fill fluid)	Process connection
JTD921A	0.75 to 100 kPa (75 to 10160 mmH <sub>2</sub> O)	Regular service (Silicon oil)	Rc1/2, 1/2NPT, Rc1/4, NPT1/4
JTD931A	35 to 700 kPa (0.35 to 7 kgf/cm <sup>2</sup> )		
JTD961A	0.25 to 14 MPa (2.5 to 140 kgf/cm <sup>2</sup> )		

		Basic model no.	Selections	Options 1	
	Measuring span	0.75 to 100 kPa (75 to 10160 mmH <sub>2</sub> O) 35 to 700 kPa (0.35 to 7 kgf/cm <sup>2</sup> ) 0.25 to 14 MPa (2.5 to 140 kgf/cm <sup>2</sup> )	JTD921A JTD931A JTD961A		
I	Output	4 to 20 mA	1		
		4 to 20 mA (Analog FSK communication) *3	2		
		Digital output (DE protocol) *2	3		
		Digital output (FOUNDATION Fieldbus protocol) *41	4		
		4 to 20 mA (HART protocol) *43	5		
II	Material	Meterbody cover	Vent / drain plugs	Wetted parts of center body	
		SUS316			E
III	Fill fluid	Regular type (Silicon oil)	1		
IV	Process connection	Rc1/2, top connection *40	A		
		Rc1/2, bottom connection *40	B		
		1/2NPT internal thread, top connection *40	F		
		1/2NPT internal thread, bottom connection *40	G		
		Rc1/4, top connection	L		
		Rc1/4, bottom connection	M		
		1/4NPT internal thread, top connection	R		
		1/4NPT internal thread, bottom connection	S		
V	Bolt / nut	Carbon steel	1		
		SUS304	2		
		SUS630	3		
<b>Option 1</b>					
VI	Electrical connection / explosion-proof	G1/2, watertight	X		
		G1/2, JIS Flameproof with 1 pc. of cable gland attached	2		
		G1/2, JIS Flameproof with 2 pcs. of cable gland attached	3		
		G1/2, Intrinsically safe *3	6		
		1/2NPT, watertight	A		
VII	Built-in indicating smart meter	None	X		
		0 to 100% linear scales *1	1		
		Engineering unit scales *1	2		
VIII	Finish	Standard	X		
		Corrosion-resistant	A		
		Corrosion-proof	B		
		Corrosion-resistant (Silver coating)	D		
IX	Burnout feature	None *2	X		
		Upper limit of output at abnormal condition	U		
		Lower limit of output at abnormal condition	D		
X	Mounting bracket	None	X		
		Carbon steel	1		
		SUS304	2		

Note 1: Range should be informed to IBQ/Factory at purchase order. Digital output (DE protocol) should be selected with upper/lower direction of burn out feature.

2: Digital output (DE protocol) can not be combined with an external zero adjustment function.

3: Analog FSK Communication can not be combined with JIS intrinsically safe.

41: Code L1 must be selected for OPTION2.

42: Burnout function can not be combined with FOUNDATION™ Fieldbus.

43: HART communication can not be combined with special burnout (3.2mA) or JIS Intrinsically safe.

\*\* ASTM B575: Hastelloy C-276 equivalent.

**Model JTD910A - Oxygen service**

Basic model no.      Selections      Options 1      Options 2 (Options 2: Refer to page 17)

- 
 

I	II	III	IV	V
---	----	-----	----	---

 - 
 

VI	VII	VIII	IX	X
----	-----	------	----	---

 -

Model	Pressure range / style	Service (Fill fluid)	Process connection
JTD910A	0.1 to 2.0 kPa (10 to 200 mmH <sub>2</sub> O)	Lowest differential pressure	Oxygen service (Fluorine oil)
			Rc1/2, 1/2NPT, Rc1/4, NPT1/4

		Basic model no.	Selections	Options-1
	Measuring span	0.1 to 2.0 kPa (10 to 200 mmH <sub>2</sub> O)	JTD910A	
I	Output	4 to 20 mA	1	
		4 to 20 mA (Analog FSK communication) *3	2	
		Digital output (DE protocol) *2	3	
		Digital output (FOUNDATION Fieldbus protocol) *41	4	
		4 to 20 mA (HART protocol) *43	5	
II	Material	Meterbody cover	Vent/drain plugs	Wetted parts of centerbody
		SUSF316	SUS316	SUS316
III	Fill fluid	For oxygen service (Fluorine oil)		2
IV	Process connection	Rc1/2, top connection	A	
		Rc1/2, bottom connection	B	
		1/2NPT internal thread, top connection	F	
		1/2NPT internal thread, bottom connection	G	
		Rc1/4, top connection	L	
		Rc1/4, bottom connection	M	
		1/4NPT internal thread, top connection	R	
		1/4NPT internal thread, bottom connection	S	
V	Bolt / nut	SUS304		2
<b>Option 1</b>				
VI	Electrical connection / explosion-proof	G1/2, watertight	X	
		G1/2, JIS Flameproof with 1 pc. of cable gland attached	2	
		G1/2, JIS Flameproof with 2 pcs. of cable gland attached	3	
		G1/2, Intrinsically safe *3	6	
		1/2NPT, watertight	A	
VII	Built-in indicating smart meter	None	X	
		0 to 100% linear scales *1	1	
		Engineering unit scales *1	2	
VIII	Finish	Standard	X	
		Corrosion-resistant	A	
		Corrosion-proof	B	
		Corrosion-resistant (Silver coating)	D	
IX	Burnout feature	None *2	X	
		Upper limit of output at abnormal condition	U	
		Lower limit of output at abnormal condition	D	
X	Mounting bracket	None	X	
		Carbon steel	1	
		SUS304	2	

Note 1: Range should be informed to IBQ/Factory at purchase order. Digital output (DE protocol) should be selected with upper/lower direction of burn out feature.

2: Digital output (DE protocol) can not be combined with an external zero adjustment function.

3: Analog FSK communication can not be combined with JIS intrinsically safe.

41: Code L1 must be selected for OPTION2.

42: Burnout function can not be combined with FOUNDATION™ Fieldbus.

43: HART communication can not be combined with special burnout (3.2mA) or JIS Intrinsically safe.

Model JTD920A / JTD930A / JTD960A - Oxygen service

Basic model no.      Selections      Options 1      Options 2 (Options 2: Refer to page 17)

-  I  II  III  IV  V -  VI  VII  VIII  IX  X -

Model	Pressure range / style	Service (Fill fluid)	Process connection
JTD920A	0.75 to 100 kPa (75 to 10160 mmH <sub>2</sub> O)	Medium differential pressure	Rc1/2, 1/2NPT, Rc1/4, NPT1/4
JTD930A	35 to 700 kPa (0.35 to 7 kgf/cm <sup>2</sup> )	High differential pressure	
JTD960A	0.25 to 14 MPa (2.5 to 140 kgf/cm <sup>2</sup> )	Super high differential pressure	

		Basic model no.	Selections	Options-1
Measuring span	0.75 to 100 kPa (75 to 10160 mmH <sub>2</sub> O)	JTD920A		
	35 to 700 kPa (0.35 to 7 kgf/cm <sup>2</sup> )	JTD930A		
	0.25 to 14 MPa (2.5 to 140 kgf/cm <sup>2</sup> )	JTD960A		
I Output	4 to 20 mA	1		
	4 to 20 mA (Analog FSK communication)	2		
	Digital output (DE protocol) *2	3		
	Digital output (FOUNDATION Fieldbus protocol) *41	4		
	4 to 20 mA (HART protocol) *43	5		
II Material	Meterbody cover	Vent/drain plugs	Wetted parts of centerbody	
	SCS14A *32	SUS316	SUS316	E
	SCS14A *32	SUS316	ASTM B575 **	F
	SUSF316	SUS316	Tantalum	H
	SUSF316	SUS316	SUS316L	K
	PVC	PVC	Tantalum	P
III Fill fluid	For oxygen service (Fluorine oil)			2
IV Process connection	Rc1/2, top connection	A		
	Rc1/2, bottom connection	B		
	1/2NPT internal thread, top connection	F		
	1/2NPT internal thread, bottom connection	G		
	Rc1/4, top connection	L		
	Rc1/4, bottom connection	M		
	1/4NPT internal thread, top connection	R		
	1/4NPT internal thread, bottom connection	S		
	Δ Probe bottom connection	W		
	V Bolt / nut	Carbon steel	1	
SUS304		2		
SUS630		3		
<b>Option 1</b>				
VI Electrical connection / explosion-proof	G1/2, watertight	X		
	G1/2, JIS Flameproof with 1 pc. of cable gland attached	2		
	G1/2, JIS Flameproof with 2 pcs. of cable gland attached	3		
	G1/2, Intrinsically safe *3	6		
	1/2NPT, watertight	A		
VII Built-in indicating smart meter	None	X		
	0 to 100% linear scales *1	1		
	Engineering unit scales *1	2		
VIII Finish	Standard	X		
	Corrosion-resistant	A		
	Corrosion-proof	B		
	Corrosion-resistant (Silver coating)	D		
IX Burnout feature	None *2	X		
	Upper limit of output at abnormal condition	U		
	Lower limit of output at abnormal condition	D		
X Mounting bracket	None	X		
	Carbon steel	1		
	SUS304	2		

- Note 1: Range should be informed to IBQ/Factory at purchase order. Digital output (DE protocol) should be selected with upper/lower direction of burn out feature.
- 2: Digital output (DE protocol) can not be combined with an external zero adjustment function.
- 3: Analog FSK Communication can not be combined with JIS intrinsically safe.
- 4: Model JTD960A is not available for meterbody cover material PVC.
- 5: The pitch is 82 mm. To change the pitch to 54 mm (standard pitch), should be selected adapter flange ("A1" of option 2).
- 6: When meterbody cover material is PVC, option 2 should be selected "V" as bolt/nut SUS304.
- 9: This can be selected for the meterbody cover if the process fluid contains hydro-carbon or H<sub>2</sub>S which used for refinery/Petrochemical. When you selected this, contact to IBQ/Factory.
- 10: When meterbody cover material is PVC, manifold valve (model MVG) and/or integral orifice (model KEE) can not be combined with.
- 32: SCS14A (equivalent to SUS316) or SUSF316
- 41: Code L1 must be selected for OPTION2.
- 42: Burnout function can not be combined with FOUNDATION™ Fieldbus.
- 43: HART communication can not be combined with special burnout (3.2mA) or JIS Intrinsically safe.
- \*\*.: ASTM B575: Hastelloy C-276 equivalent

**Model JTD921A / JTD931A / JTD961A - Oxygen service**

Basic model no.      Selections      Options 1      Options 2 (Options 2: Refer to page 17)

- 
 

I	II	III	IV	V
---	----	-----	----	---

 - 
 

VI	VII	VIII	IX	X
----	-----	------	----	---

 -

Model	Pressure range / style	Service (Fill fluid)	Process connection
JTD921A	0.75 to 100 kPa (75 to 10160 mmH <sub>2</sub> O)	Oxygen service (Fluorine oil)	Rc1/2, 1/2NPT, Rc1/4, NPT1/4
JTD931A	35 to 700 kPa (0.35 to 7 kgf/cm <sup>2</sup> )		
JTD961A	0.25 to 14 MPa (2.5 to 140 kgf/cm <sup>2</sup> )		

		Basic model no.	Selections	Options-1						
	Measuring span	<table border="1"> <tr> <td>0.75 to 100 kPa (75 to 10160 mmH<sub>2</sub>O)</td> <td>JTD921A</td> </tr> <tr> <td>35 to 700 kPa (0.35 to 7 kgf/cm<sup>2</sup>)</td> <td>JTD931A</td> </tr> <tr> <td>0.25 to 14 MPa (2.5 to 140 kgf/cm<sup>2</sup>)</td> <td>JTD961A</td> </tr> </table>	0.75 to 100 kPa (75 to 10160 mmH <sub>2</sub> O)	JTD921A	35 to 700 kPa (0.35 to 7 kgf/cm <sup>2</sup> )	JTD931A	0.25 to 14 MPa (2.5 to 140 kgf/cm <sup>2</sup> )	JTD961A		
0.75 to 100 kPa (75 to 10160 mmH <sub>2</sub> O)	JTD921A									
35 to 700 kPa (0.35 to 7 kgf/cm <sup>2</sup> )	JTD931A									
0.25 to 14 MPa (2.5 to 140 kgf/cm <sup>2</sup> )	JTD961A									
I	Output	4 to 20 mA	1							
		4 to 20 mA (Analog FSK communication)	2							
		Digital output (DE protocol) *2	3							
		Digital output (FOUNDATION Fieldbus protocol) *41	4							
		4 to 20 mA (HART protocol) *43	5							
II	Material	Meterbody cover	Vent / drain plugs	Wetted parts of center body	E					
		SUSF316	SUS316	SUS316						
III	Fill fluid	For oxygen service (Fluorine oil)		2						
IV	Process connection	Rc1/2, top connection *40		A						
		Rc1/2, bottom connection *40		B						
		1/2NPT internal thread, top connection *40		F						
		1/2NPT internal thread, bottom connection *40		G						
		Rc1/4, top connection		L						
		Rc1/4, bottom connection		M						
		1/4NPT internal thread, top connection		R						
		1/4NPT internal thread, bottom connection		S						
V	Bolt / nut	Carbon steel		1						
		SUS304		2						
		SUS630		3						
<b>Option 1</b>										
VI	Electrical connection / explosion-proof	G1/2, watertight		X						
		G1/2, JIS Flameproof with 1 pc. of cable gland attached		2						
		G1/2, JIS Flameproof with 2 pcs. of cable gland attached		3						
		G1/2, Intrinsically safe *3		6						
		1/2NPT, watertight		A						
VII	Built-in indicating smart meter	None		X						
		0 to 100% linear scales *1		1						
		Engineering unit scales *1		2						
VIII	Finish	Standard		X						
		Corrosion-resistant		A						
		Corrosion-proof		B						
		Corrosion-resistant (Silver coating)		D						
IX	Burnout feature	None *2		X						
		Upper limit of output at abnormal condition		U						
		Lower limit of output at abnormal condition		D						
X	Mounting bracket	None		X						
		Carbon steel		1						
		SUS304		2						

- Note 1: Range should be informed to IBQ/Factory at purchase order. Digital output (DE protocol) should be selected with upper/lower direction of burn out feature.
- 2: Digital output (DE protocol) can not be combined with an external zero adjustment function.
- 3: Analog FSK Communication can not be combined with JIS intrinsically safe.
- 40: Not available with NZ16 high pressure manifold valve.
- 41: Code L1 must be selected for OPTION2.
- 42: Burnout function can not be combined with FOUNDATION™ Fieldbus.
- 43: HART communication can not be combined with special burnout (3.2mA) or JIS Intrinsically safe.

**Model JTD920A / JTD930A / JTD960A - Chlorine service**

Basic model no.      Selections      Options 1      Options 2 (Options 2: Refer to page 17)

- 
 

I	II	III	IV	V
---	----	-----	----	---

 - 
 

VI	VII	VIII	IX	X
----	-----	------	----	---

 -

Model	Pressure range / style	Service (Fill fluid)	Process connection
JTD920A	0.75 to 100 kPa (75 to 10160 mmH <sub>2</sub> O)	Medium differential pressure	Chlorine service (Fluorine oil)  Rc1/2, 1/2NPT, Rc1/4, NPT1/4
JTD930A	35 to 700 kPa (0.35 to 7 kgf/cm <sup>2</sup> )	High differential pressure	
JTD960A	0.25 to 14 MPa (2.5 to 140 kgf/cm <sup>2</sup> )	Super high differential pressure	

		Basic model no.	Selections	Options 1	Options 2
	Measuring span	0.75 to 100 kPa (75 to 10160 mmH <sub>2</sub> O) 35 to 700 kPa (0.35 to 7 kgf/cm <sup>2</sup> ) 0.25 to 14 MPa (2.5 to 140 kgf/cm <sup>2</sup> )	JTD920A JTD930A JTD960A		
I	Output	4 to 20 mA	1		
		4 to 20 mA (Analog FSK communication)	2		
		Digital output (DE protocol) *2	3		
		Digital output (FOUNDATION Fieldbus protocol) *41	4		
		4 to 20 mA (HART protocol) *43	5		
II	Material	Meterbody cover	Vent/drain plugs	Wetted parts of centerbody	
		*5 SUSF316	SUS316	Tantalum	H
		*4, 5, 6, 10 PVC *3	PVC	Tantalum	P
III	Fill fluid	For chlorine service (Fluorine oil)			5
IV	Process connection	Rc1/2, top connection	A		
		Rc1/2, bottom connection	B		
		1/2NPT internal thread, top connection	F		
		1/2NPT internal thread, bottom connection	G		
		Rc1/4, top connection	L		
		Rc1/4, bottom connection	M		
		1/4NPT internal thread, top connection	R		
		1/4NPT internal thread, bottom connection	S		
		Δ Probe bottom connection	W		
		V	Bolt / nut	Carbon steel	1
		SUS304	2		
		SUS630	3		
<b>Option 1</b>					
VI	Electrical connection / explosion-proof	G1/2, watertight	X		
		G1/2, JIS Flameproof with 1 pc. of cable gland attached	2		
		G1/2, JIS Flameproof with 2 pcs. of cable gland attached	3		
		G1/2, Intrinsically safe *3	6		
		1/2NPT, watertight	A		
VII	Built-in indicating smart meter	None	X		
		0 to 100% linear scales *1	1		
		Engineering unit scales *1	2		
VIII	Finish	Standard	X		
		Corrosion-resistant	A		
		Corrosion-proof	B		
		Corrosion-resistant (Silver coating)	D		
IX	Burnout feature	None *2	X		
		Upper limit of output at abnormal condition	U		
		Lower limit of output at abnormal condition	D		
X	Mounting bracket	None	X		
		Carbon steel	1		
		SUS304	2		

- Note 1: Range should be informed to IBQ/Factory at Purchase order. Digital output (DE protocol) should be selected with upper/lower direction of burn out feature.
- 2: Digital output (DE protocol) can not be combined with an external zero adjustment function.
  - 3: Analog FSK Communication can not be combined with JIS intrinsically safe.
  - 4: Model JTD960A is not available for meterbody cover material PVC.
  - 5: The pitch is 82 mm. To change the pitch to 54 mm (standard pitch), should be selected adapter flange ("A1" of option 2).
  - 6: When meterbody cover material is PVC, option 2 should be selected "V" as bolt/nut SUS304.
  - 10: When meterbody cover material is PVC, manifold valve (model MVG) and/or integral orifice (model KEE) can not be combined with.
  - 41: Code L1 must be selected for OPTION2.
  - 42: Burnout function can not be combined with FOUNDATION™ Fieldbus.
  - 43: HART communication can not be combined with special burnout (3.2mA) or JIS Intrinsically safe.

## Option 2

Options 2	XX	No options
	A1	Adapter flange for corrosion-resistant application (SUS316L or Tantalum for the wetted parts of centerbody)
	A2	External Zero adjustment *2
	A4	Lightning arrestor
	A5	Long vent/drain plugs
	B2	Steam block
	B7	For mounting a high load resistance smart meter *23
	C1	Color: Red (Munsell 5R4/13)
	C2	Color: Yellow (Munsell 2.5Y8/16)
	C3	Color: Blue (Munsell 7.5BG7/2)
	C7	Process connection; reverse
	D1	Water free finish (included oil free finish) *16, *17
	D2	Oil free finish *16, *17
	G1	One elbow (left)
	G2	One elbow (right)
	G3	2 elbows
	J8	Special burn-out feature (3.2 mA) *18
	L1	Fieldbus communication stack BASIC class
	K9	Output saturation point changeable
	T1	Test report
	T2	Material certificate *19
	T5	Strength calculation sheet *33
	T6	Withstand pressure and Airtight test *34
	T8	Traceability certificate
	U2	Non-SI unit conformance
	<input type="checkbox"/>	Others

Note 2: Digital output (DE protocol) can not be combined with an External zero adjustment function.

16: When the fill fluid is for oxygen or chlorine service, there is no need to select.

17: The carbon steel for meterbody cover material is not available for this option.

18: "Lower limit of output at abnormal condition" - code D must be selected for options 1 "V", Burnout feature.

19: Available only for material of wetted part.

20: When order-entry, designed pressure and designed temperature are required.

21: When ordering, resistant pressure and gas-tightness test pressure are required.

22: Steam block is not available for model JTD921/931/961.

23: When this transmitter connected with NW35, NWS300, this option must be selected.

33: Specify design pressure and design temperature.

34: Specify required test pressures (up to the max. working pressure).

**DIMENSIONS**

[Unit: mm]

**Model JTD910A /JTD920A /JTD930A (SUS316, ASTM B575 (Hastelloy C-276 equivalent))**

**Model JTD960A (SUS316)**

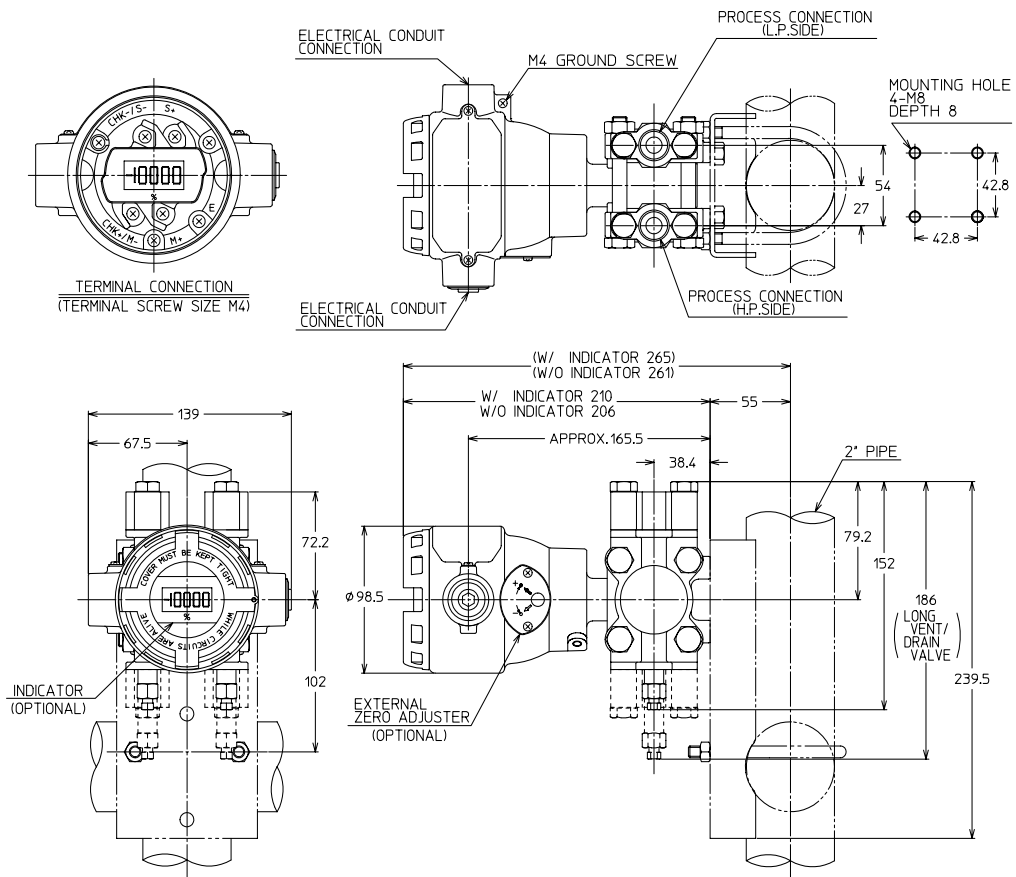

Model JTD921A / JTD931A / JTD961A

[Unit: mm]

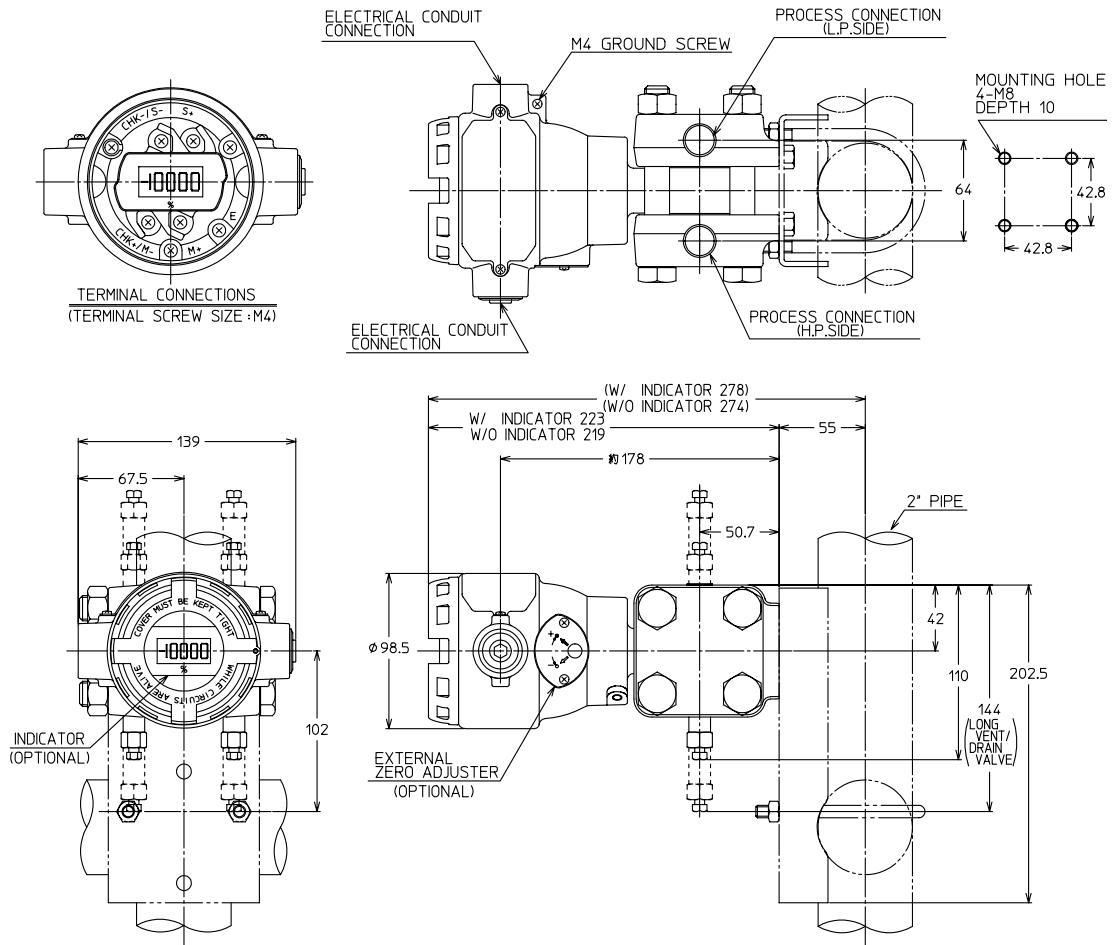

Model JTD920A/930A (Tantalum, SUS316L)

Model JTD960A (ASTM B575 (Hastelloy C-276 equivalent), Tantalum, SUS316L) [Unit: mm]

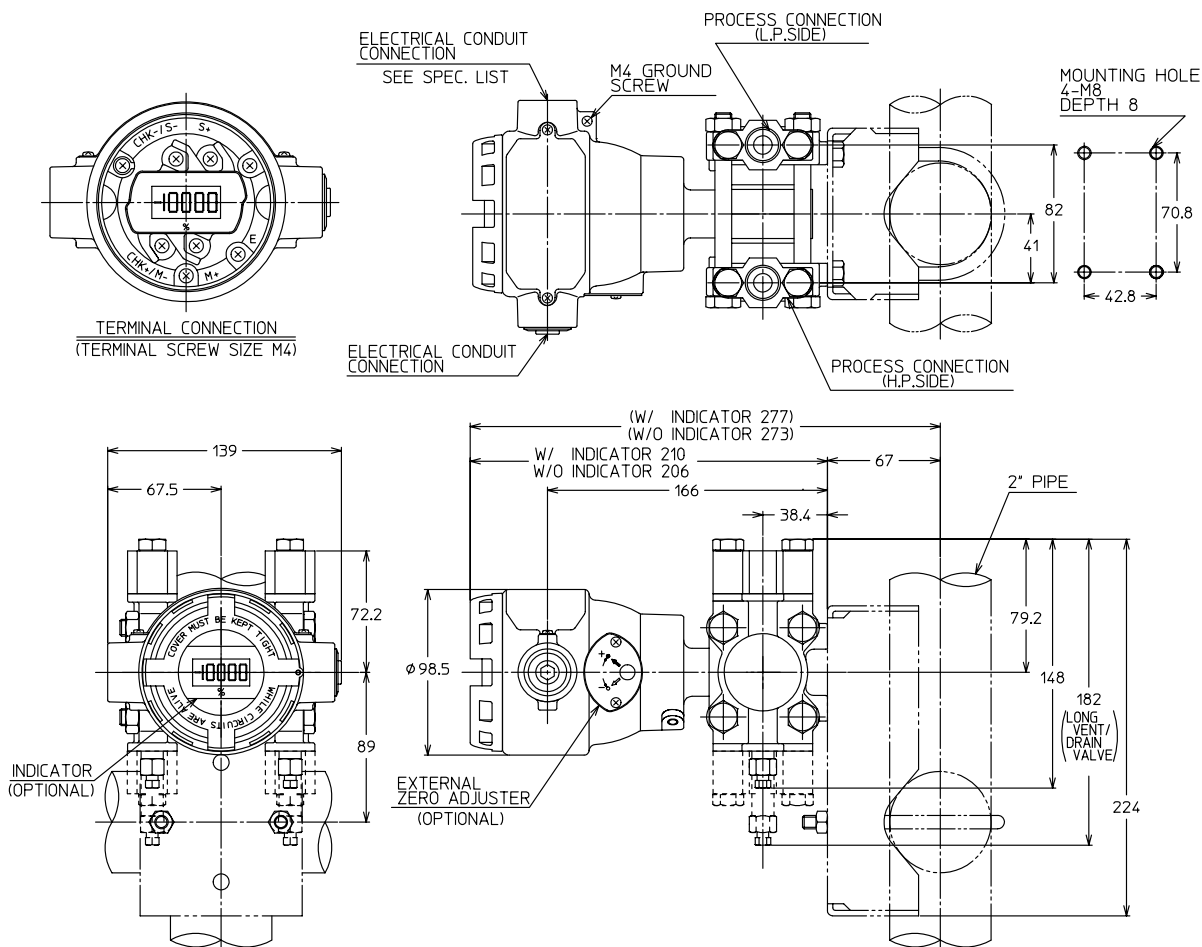

Note) The suppression > adjustment Span/2  
 A high pressure and a low pressure side of the process piping connection become it contrary to figure.  
 Please follow the figure, if measuring the level with liquid seal.

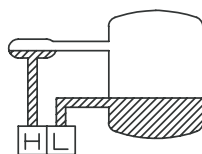

Yamatake Corporation  
 Advanced Automation Company

1-12-2 Kawana, Fujisawa  
 Kanagawa 251-8522 Japan

URL: <http://www.azbil.com>