

ST 3000 Smart Transmitter Electronic Differential Pressure Transmitter

Model JTR226 (Remote-Sealed Type for Hi-Temperature and Hi-Temperature-Vacuum Service, with Temperature Compensation for Enclosed Liquid in Capillary Tube)
Measuring Span: 250 to 10000mmH₂O

Introduction

The ST 3000 Differential Pressure Transmitter measures a differential pressure and transmits an analog 4 to 20mA DC output or digital output proportional to the measured variable. The transmitter is a microprocessor-based instrument, whose parameters and settings (range, damping time constant, linear or square-root output, constant current output and others) can be remote-controlled from the instrument room via the SFC (Smart Communicator).

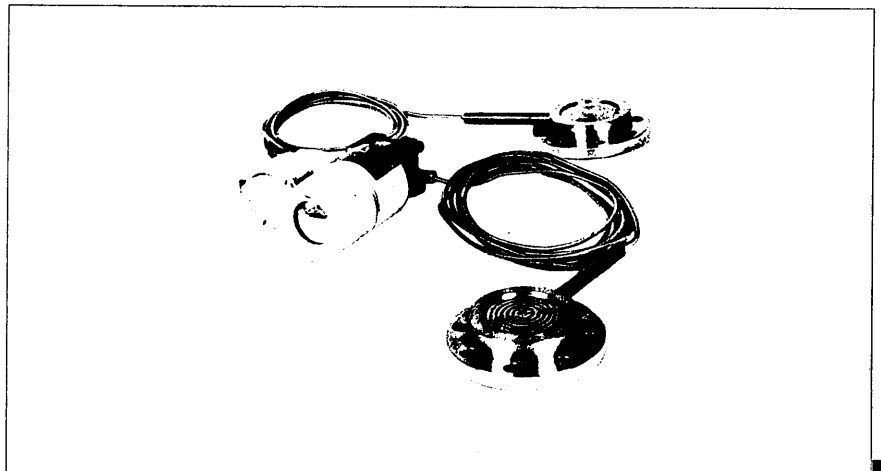

Standard Specifications

Item	Specifications		
Measuring span (Continuously adjustable)	250 to 10000mmH ₂ O		
Setting range	- 10000 ≤ URV ^(#1) ≤ 10000mmH ₂ O, - 10000 ≤ LRV ^(#2) ≤ 10000mmH ₂ O		
Output	Analog output (4 to 20mA DC) / Digital output		
Accuracy ^(#3)	Percentage with respect to x (mmH ₂ O) that represents the URV or LRV of the calibrated range, or the span - whichever is greatest. ± 0.2% When x is 1250mmH ₂ O or greater. ± [0.15 + (0.05 × $\frac{1250}{x}$)]% When x is less than 1250mmH ₂ O. (with damping effected)		
Supply voltage and load resistance	10.8 to 45V DC (See Figure 1.)		
Working pressure rating	Up to flange pressure rating (For vacuum pressure, see Figures 2 and 3.)		
Operating temperature range	Ambient temperature: Normal operating conditions; - 5 to + 55°C Operative limits (for short period); - 10 to + 60°C Transportation and storage conditions; - 20 to + 85°C Meter body (Process fluid) temperature: Normal operating conditions; - 5 to + 280°C Operative limits (for short period); - 10 to + 310°C		
Operating humidity range	Normal operating conditions: 10 to 90% RH		
Temperature effect ^(#3) (Shift with respect to setting range)	Percentage with respect to x (mmH ₂ O) that represents the URV or LRV of the setting range, or the span - whichever is greatest.		
		High temperature service	High temperature and vacuum service
	Zero shift	± [0.25 + (0.25 × $\frac{2500}{x}$)]% / 55°C change	± [0.15 + (1.0 × $\frac{2500}{x}$)]% / 30°C change
Static Pressure effect ^(#3)	Percentage with respect to x (mmH ₂ O) that represents the URV or LRV of the setting range, or the span - whichever is greatest (P: Static pressure value)		
		High temperature service	High temperature and vacuum service
	Zero shift	± [0.03 + (0.07 × $\frac{P}{70}$ + 0.35 × $\frac{P}{70}$) × $\frac{2500}{x}$]%	± [0.03 + (0.76 × $\frac{2500}{x}$)]% / 10kgf/cm ² change
Combined shift (including zero and span shift)	± [0.03 + (0.2 × $\frac{P}{70}$ + 0.4 × $\frac{P}{70}$)]%: ... When x is 2500mmH ₂ O or greater. ± [0.03 + (0.2 × $\frac{P}{70}$ + 0.4 × $\frac{P}{70}$) × $\frac{2500}{x}$]%: ... When x is less than 2500mmH ₂ O.	± [0.24 + (0.71 × $\frac{2500}{x}$)]% / 10kgf/cm ² change ... When x is 2500mmH ₂ O or greater. ± [0.1 + (0.85 × $\frac{2500}{x}$)]% / 10kgf/cm ² change ... When x is less than 2500mmH ₂ O.	

(*1): URV denotes the value for 100% (20mA DC) output.
(*2): LRV denotes the value for 0% (4mA DC) output.
(*3): Within a range of URV ≥ 0 and LRV ≥ 0.

(*4): For the performance and external dimensions of corrosion-resistant type, refer to the specification sheet for corrosion-resistant application.

Item	Specifications
Stability against supply voltage change	0.005% FS/V
Dead time	Approx. 0.4 sec.
Damping time constant	Adjustable within a range of 2.5 to 32 sec. by 10 steps. (at 25°C with 5 meter capillary tube)
Process connection	Flange (Both high and low pressure sides) { Flush diaphragm type; JIS10K, 30K – 80mm (RF) equivalent ANSI150, 300 – 3" (RF) equivalent JPI150, 300 – 3" (RF) equivalent Extended diaphragm type; JIS10K, 30K – 100mm (RF) equivalent ANSI150, 300 – 4" (RF) equivalent JPI150, 300 – 4" (RF) equivalent }
Electrical conduit connection	G $\frac{1}{2}$ internal thread
Structure	Water-proof and dust-proof structure: JIS C0920 water-tight, JIS F8001 Class 2 water-tight, NEMA 3 and 4X, IEC IP67
Materials	Center body: SUS316 Meter body cover: SUSF304 Bolts: SNB7 Flange: Carbon steel (SF45A), SUS304 Wetted parts: For hi-temp. service SUS316 (Diaphragm: SUS316L) For hi-temp.-vacuum service SUS316L Capillary tube: SUS316 Armored tube: SUS304 Transmitter case: Aluminium alloy
Finish	Baked acryl paint, light beige (Munsell 4Y 7.2/1.3)
Installation	Direct mounting on a process flange (Transmitter body is mounted on a 2-inch horizontal or vertical pipe.)
Length of capillary tube	2, 3 or 5 meters (Specific gravity of the fill fluid is 1.07 at 25°C.)
Weight	Approx. 20.5kg (with JIS10K – 80mm flange and 5 meter capillary tube)

Selectable Standard Specifications

(The items other than the following are identical with those of the Standard Specifications.)

Item	Specifications
Material of wetted parts	Tantalum (Flush diaphragm only) Meter body (Process fluid) temperature: Normal operating conditions; – 5 to +180°C Operative limits (for short period); – 10 to +200°C
	Hastelloy C (Flush diaphragm only) Meter body (Process fluid) temperature: Normal operating conditions; – 5 to +280°C Operative limits (for short period); – 10 to +310°C

Optional Specifications

(The items other than the following are identical with those of the Standard Specifications.)

Item	Specifications
Built-in indicating meter (Class 2.5)	Ambient temperature: Normal operating conditions; – 5 to +55°C Operative limits (for short period); – 10 to +60°C Transportation and storage conditions; – 20 to +85°C
Corrosion-resistant finish	Corrosion-resistant paint (Baked acryl paint), fungus-proof finish. (Silver paint when bolts and flanges are made of carbon steel.)
Corrosion-proof finish	Corrosion-proof paint (Baked epoxy paint), fungus-proof finish. (Silver paint when bolts and flanges are made of carbon steel.)
Corrosion-resistant finish (Silver paint)	Transmitter case is silver-painted in addition to the above corrosion-resistant finish.
Flame-proof packing type cable connecting adaptor	For electrical connection by the leading-in method of flame-proof packing type for special flame-proof structure.
Explosion-proof structure	JIS C0903 ds2G4 special flame-proof structure (Ambient temperature: – 5 to +55°C Meter body (Process fluid) temperature: – 5 to +280°C) JIS C0903 i3aG4 intrinsic-safety explosion-proof structure, using Zener barrier 8907/51 – 24/45 (Approval No. 29911) (Ambient temperature: – 5 to +55°C Meter body (Process fluid) temperature: – 10 to +280°C) FM flame-proof structure Explosion-proof Class I (Gas, steam), Division 1, Group B, C, D Dust-ignition Class II (Inflammable dust), Division 1, Group E, F, G Suitable Class III (Inflammable fiber), Division 1 FM intrinsic-safety explosion-proof structure Intrinsically safe Class I, II, III, Division 1, Group A, B, C, D, E, F, G Nonincendive (for Class 2 location) Class I, Division 2, Group A, B, C, D

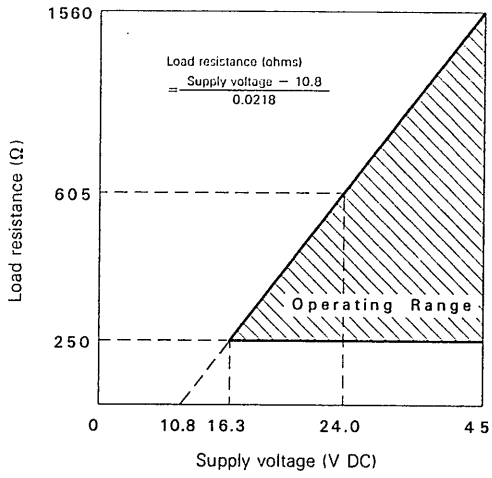

Note: For communication with SFC, a load resistance of 250 ohms or more is needed.

Fig.1 Supply voltage vs load resistance characteristics

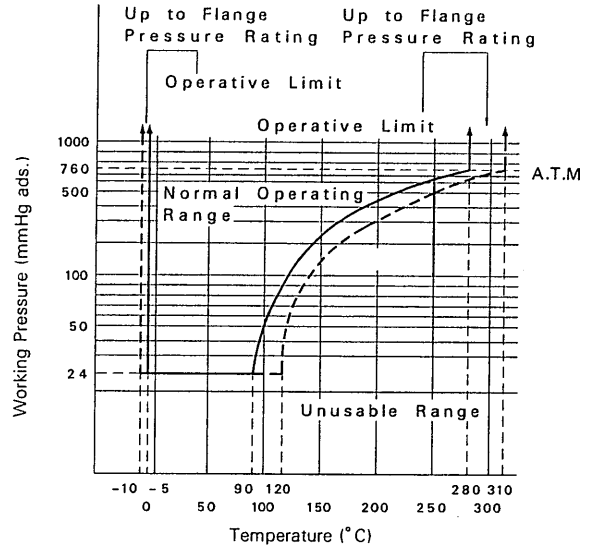

Fig.2 Working pressure and temperature of wetted parts (for hi-temp.)

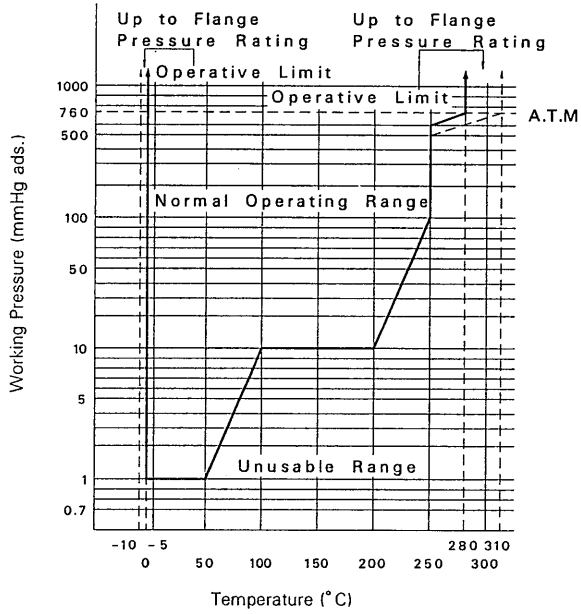

Fig.3 Working pressure and temperature of wetted parts (for hi-temp. -vacuum)

Model Number Table

Basic Model Number	Fill Fluid	Flange							Options I	Options II	Description	
		Standard	Type and Rating	Flange Material	Material of Wetted Parts	Finish of Gasket Face	Length of Extended Parts	Capillary Tube Length				
JTR226											Measuring span: 250 to 10000mmH ₂ O	
	-3										For hi-temperature service (Silicon oil)	
	-4										For hi-temperature-vacuum service (Silicon oil) (Note 2)	
			J									JIS flange
			A									ANSI flange
			P									JPI flange
				A								Flush diaphragm type 10K - 80mm/150 - 3" (RF) equivalent
				B								Flush diaphragm type 30K - 80mm/300 - 3" (RF) equivalent
				C								Extended diaphragm type 10K - 100mm/150 - 4" (RF) equivalent
				D								Extended diaphragm type 30K - 100mm/300 - 4" (RF) equivalent
					1							Carbon steel (SF45A)
					2							SUS316
					7							SUS304
						2						SUS316 (Diaphragm: SUS316L)
						4						Tantalum (for hi-temp. service and flush diaphragm only) (Note 3)
						8						SUS316L
						9						Hastelloy C (for hi-temp. service and flush diaphragm only) (Note 3)
							J					Standard
								00				Flush diaphragm
								05				L = 50mm (Extended diaphragm)
								10				L = 100mm (Extended diaphragm)
								15				L = 150mm (Extended diaphragm)
									2			ℓ = 2m
									3			ℓ = 3m
									5			ℓ = 5m
									-X			No option
									-L			Built-in lightning arrester
									-M			Built-in indicating meter (0 to 100% linear and 0 to 10 √ double scales)
									-A			Corrosion-resistant finish
									-B			Corrosion-proof finish
									-D			Corrosion-resistant finish, silver paint
									-N			½NPT internal-thread electrical conduit connection
									-K			No oil finish
								-P			One cable adaptor with flame-proof packing	
								-Q			Two cable adaptors with flame-proof packing	
								-R			Specification for power plant application	
								-1			JIS special flame-proof structure	
								-2			JIS intrinsic-safety explosion-proof structure	
								-3			FM flame-proof structure	
								-4			FM intrinsic-safety explosion-proof structure	
								-9			Vertical pressure-conduit connection, right side electrical-conduit connection type	
								-XX			No options	
								-A2			With external zero adjustment (Unavailable combination with FM explosion-proof structure)	
								-A5			Burnout feature (Upper limit of output value at abnormal condition)	
								-D1			With DE meter	

Notes:

- 1) The items enclosed in the bold-line boxes are for Standard Specifications.
- 2) Material for connecting section must be combined with SUS316L.
- 3) Combination with enclosed fluid "4" is scheduled to be released shortly.

5

FLUSH DIAPHRAGM TYPE

(Unit: mm)

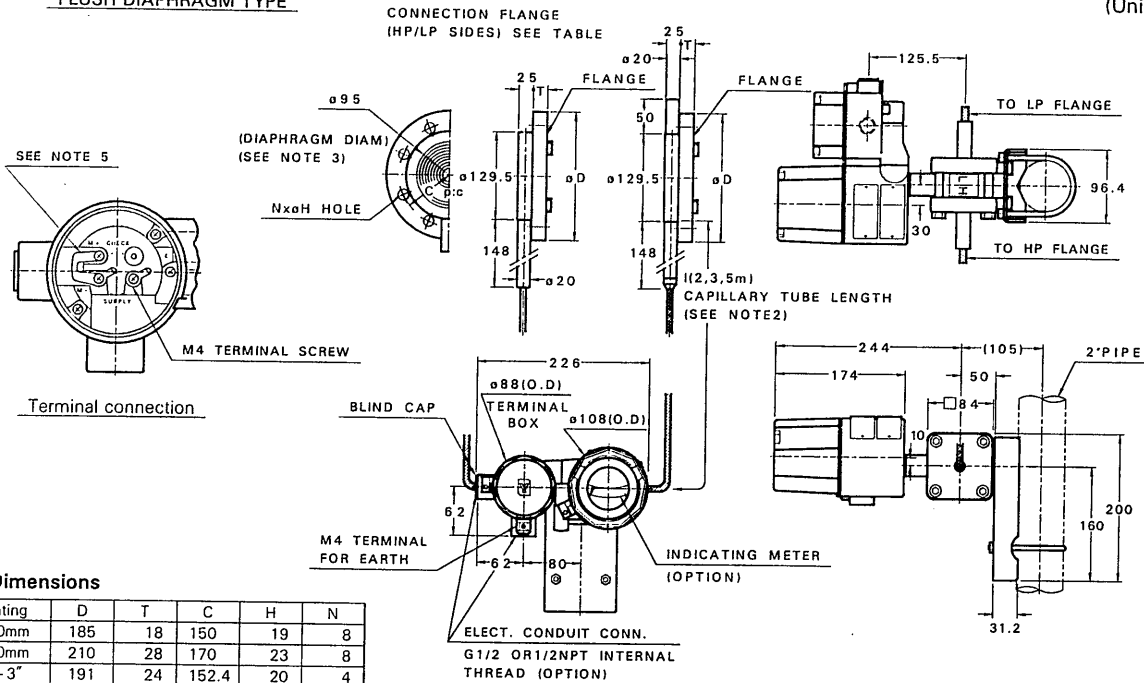

Flange Dimensions

Flange Rating	D	T	C	H	N
JIS 10K - 80mm	185	18	150	19	8
JIS 30K - 80mm	210	28	170	23	8
ANSI 150 - 3"	191	24	152.4	20	4
ANSI 300 - 3"	210	29	168.3	23	8
JPI 150 - 3"	191	24	152.4	20	4
JPI 300 - 3"	210	29	168.3	23	8
JIS 10K - 100mm	210	18	175	19	8
JIS 30K - 100mm	240	32	195	25	8
ANSI 150 - 4"	229	24	190.5	20	8
ANSI 300 - 4"	254	32	200	23	8
JPI 150 - 4"	229	24	190.5	20	8
JPI 300 - 4"	254	32	200	23	8

EXTENDED DIAPHRAGM TYPE

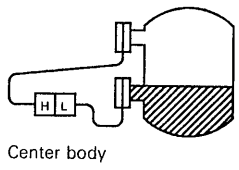
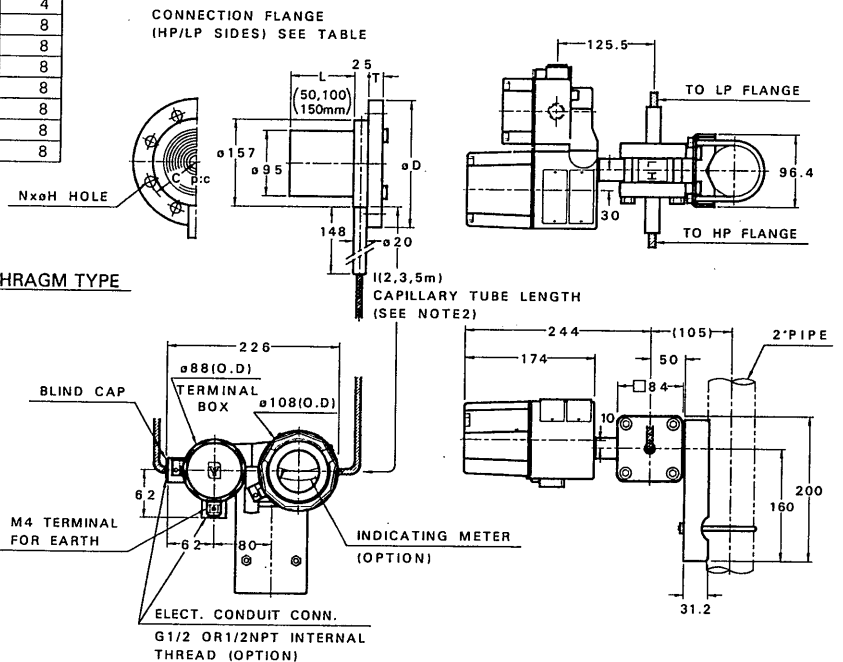

Center body
For liquid level measurement, make process connection at "H" and "L" marks on the center body.

Caution on Process Connection

- Notes:
- 1) This transmitter can be mounted in various ways by using the holes of the mounting bracket. (The above drawing shows an example of typical mounting.)
 - 2) It is recommended to fix the capillary tube at a midposition in order to prevent mechanical vibration.
 - 3) Select a gasket that will not touch the diaphragm after being fastened.
 - 4) Mount the transmitter vertically.
 - 5) To use an external indicating meter, disconnect the jumper bar from the M terminals and connect in its place the lead-wires of the external indicating meter.
 - 6) For process connection, it means:
 - a) High pressure (H) side ... relatively higher pressure applied to sensor
 - b) Low pressure (L) side ... relatively lower pressure applied to sensor
 Therefore, if suppression amount > (adjustable span)/2, actual "H" and "L" sides become reversal to those indicated.

Fig. 5 Dimension drawing

*Specifications are subject to change without notice.