

ST 3000 Smart Transmitter

Electronic Differential Pressure Transmitter

Model JTD210 (Standard Type for Lowest Differential Pressure)

Measuring Span: 10 to 200mmH₂O (Measuring Range: -100 to +100mmH₂O)

Introduction

The ST 3000 Differential Pressure Transmitter measures a differential pressure and transmits an analog 4 to 20mA DC output or digital output proportional to the measured variable. The transmitter is a microprocessor-based instrument, whose parameters and settings (range, damping time constant, linear or square-root output, constant current output and others) can be remote-controlled from the instrument room via the SFC (Smart Communicator).

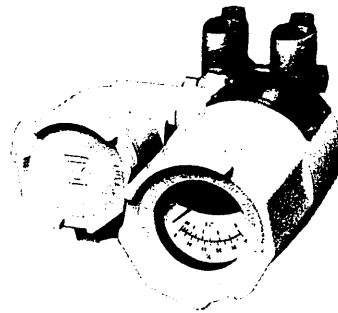

Standard Specifications

Item	Specifications		
Measuring span (Continuously adjustable)	10 ^(*4) to 200mmH ₂ O (Measuring range: -100 to +100mmH ₂ O)		
Setting range	-100 ≤ URV ^(*1) ≤ 100mmH ₂ O, -100 ≤ LRV ^(*2) ≤ 100mmH ₂ O		
Output	Analog output (4 to 20mA DC) / Digital output		
Accuracy ^(*3)	Percentage with respect to x (mmH ₂ O) that represents the URV or LRV of the calibrated range, or the span - whichever is greatest.		
		General Use	High Performance Type
	Linear output	$\pm [0.15 + (0.15 \times \frac{100}{x})]\%$	$\pm 0.3\%$, x : 30mmH ₂ O or more $\pm 0.5\%$, x : Less than 30mmH ₂ O
Supply voltage and load resistance	10.8 to 45V DC (See Figure 1.)		
Working pressure rating	-0.70 to +0.70kgf/cm ² G (For vacuum pressures, see Figure 2.)		
Operating temperature range	Ambient temperature: Normal operating conditions; -15 to +65°C Operative limits (for short period); -40 to +70°C Transportation and storage conditions; -40 to +70°C Meter body (Process fluid) temperature: Normal operating conditions; -15 to +65°C Operative limits (for short period); -40 to +70°C		
Operating humidity range	Normal operating conditions: 10 to 90% RH		
Temperature effect ^(*4) (Shift with respect to setting range)	Percentage with respect to x (mmH ₂ O) that represents the URV or LRV of the setting range, or the span - whichever is greatest.		
		General Use	High Performance Type
	Zero shift	$\pm [0.15 + (0.35 \times \frac{100}{x})]\%/30^\circ\text{C change}$	$\pm [0.15 + (0.2 \times \frac{100}{x})]\%/30^\circ\text{C change}$
Combined shift (Including zero and span shift)	$\pm [0.2 + (0.6 \times \frac{100}{x})]\%/30^\circ\text{C change}$	$\pm [0.2 + (0.45 \times \frac{100}{x})]\%/30^\circ\text{C change}$	

(*1): URV denotes the value for 100% (20mA DC) output.

(*2): LRV denotes the value for 0% (4mA DC) output.

(*3): Within a range of URV ≥ 0 and LRV ≥ 0.

(*4): Refer to the temperature effect diagram (Figure 3).

(*5): When to be used at less than 100mmH₂O, consult us.

Item	Specifications
Stability against supply voltage change	0.005%FS / V
Dead time	Approx. 0.4 sec.
Damping time constant	Adjustable within a range of 0.4 to 32 sec. by 10 steps. (at 25°C)
Process connection	Rc $\frac{1}{2}$, $\frac{1}{2}$ NPT internal thread, Rc $\frac{1}{4}$, $\frac{1}{4}$ NPT internal thread
Electrical conduit connection	G $\frac{1}{2}$ internal thread
Structure	Water-proof and dust-proof structure JIS C0920 water-tight, JIS F8001 Class 2 water-tight, NEMA 3 and 4X, IEC IP67
Materials	Center body: SUS316 Wetted parts of center body: SUS316 (Diaphragm: SUS316L) Meter body cover (Differential pressure chambers): SUSF316 Bolts: SUS304 Nuts: SUS304 Gasket: Teflon Transmitter case: Aluminium alloy
Finish	Baked acryl paint, light beige (Munsell 4Y 7.2 / 1.3)
Burnout feature	Lower limit of output value at abnormal condition
Installation	Can be installed on a 2-inch horizontal or vertical pipe. (Can be directly mounted on a process pipe.)
Weight	Approx. 7.5kg

Optional Specifications

(The items other than the following are identical with those of the Standard Specifications.)

Item	Specifications
Built-in indicating meter (Class 2.5)	Ambient temperature: Normal operating conditions; -10 to +60°C Operative limits (for short period) and transportation and storage conditions; -40 to +70°C
Steam block	Operable temperature (Steam block): 250°C max. (65°C max. for meter body) (Not available when rear connection is specified.)
Corrosion-resistant finish	Corrosion-resistant paint (Baked acryl paint), fungus-proof finish. (Silver paint when manifold valves are made of carbon steel.)
Corrosion-proof finish	Corrosion-proof paint (Baked epoxy paint), fungus-proof finish. (Silver paint when manifold valves are made of carbon steel.)
Corrosion-resistant finish (Silver paint)	Transmitter case is silver-painted in addition to the above corrosion-resistant finish.
Flame-proof packing type cable connecting adaptor	For electrical connection by the leading-in method of flame-proof packing type for special flame-proof structure.
Explosion-proof structure	JIS C0903 ds2G4 special flame-proof structure (Ambient temperature: -10 to +65°C, Meter body (Process fluid) temperature: -10 to +65°C) JIS C0903 i3aG4 intrinsic-safety explosion-proof structure, using Zener barrier 8907/51-24/45 (Approval No. 29911) (Ambient temperature: -10 to +60°C, Meter body (Process fluid) temperature: -10 to +65°C) FM flame-proof structure Explosion-proof Class I (Gas, steam), Division 1, Group B, C, D Dust-ignition Class II (Inflammable dust), Division 1, Group E, F, G Suitable Class III (Inflammable fiber), Division 1 FM intrinsic-safety explosion-proof structure Intrinsically safe Class I, II, III, Division 1, Group A, B, C, D, E, F, G Nonincendive (for Class 2 location) Class I, Division 2, Group A, B, C, D

Model Number Table

Basic Model Number	Selection I			Selection II	Options I	Options II	Description
	Material	Fill Fluid	Process Connection				
JTD210							Measuring span: 10 to 200 mmH ₂ O
	-E						Meter body cover Vent / drain plugs Watted parts of center body
							SUSF316 SUS316 SUS316 (Diaphragm:SUS316L)
		1					Regular type (Silicone Oil)
			Q				Rc 1/2 Top or bottom connection
			R				1/2 NPT internal thread Top or bottom connection
			S				Rc 1/4 Top or bottom connection
			T				1/4 NPT internal thread Top or bottom connection
			L				Rc 1/2 Rear connection ✓
			G				1/2 NPT internal thread Rear connection
			D				Rc 1/4 Rear connection
			A				1/4 NPT internal thread Rear connection
				-00000			No selection
					-W		SUS304 bolts and nuts material (See note 2)
					-L		Built-in lightning arrester
					-M		Built-in indicating meter (0 to 100% linear and 0 to 10 √ double scales)
					-A		Corrosion-resistant finish
					-B		Corrosion-proof finish
					-D		Corrosion-resistant finish, silver paint
					-N		1/2 NPT internal-thread electrical conduit connection
					-K		No oil finish
					-P		One cable adaptor with flame-proof packing
					-Q		Two cable adaptors with flame-proof packing
					-R		Specification for power plant application
					-V		High performance type
					-J		Long vent / drain plugs
					-1		JIS special flame-proof structure
					-2		JIS intrinsic-safety explosion-proof structure
					-3		FM flame-proof structure
					-4		FM intrinsic-safety explosion-proof structure
					-8		Horizontal pressure-conduit connection type (Process connection is only for the front. Combination with indicating meter is not possible. When corrosion-resistant type is required, consult us.
					-9		Vertical pressure-conduit connection, right-side electrical-conduit connection type
					-XX		No options
					-A2		With external zero adjustment (Unavailable combination with FM explosion-proof structure)
					-A5		Burnout feature (Upper limit of output value at abnormal condition)
					-D1		With DE meter

Notes: 1) The items enclosed in the bold-line boxes are for Standard Specifications.
 2) When ordering, write "w" in options I.

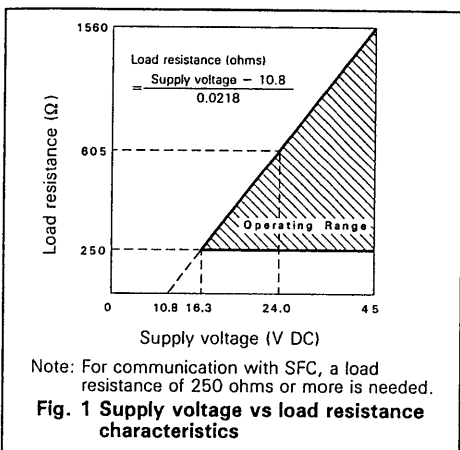

Note: For communication with SFC, a load resistance of 250 ohms or more is needed.

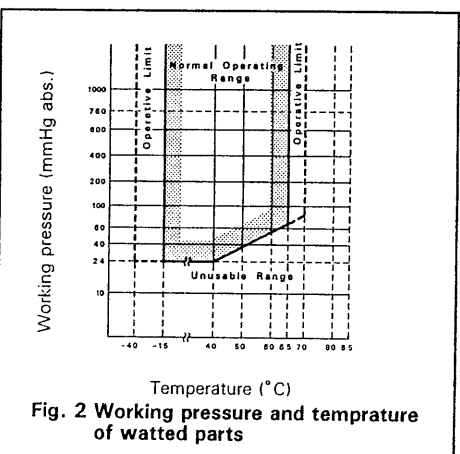

5

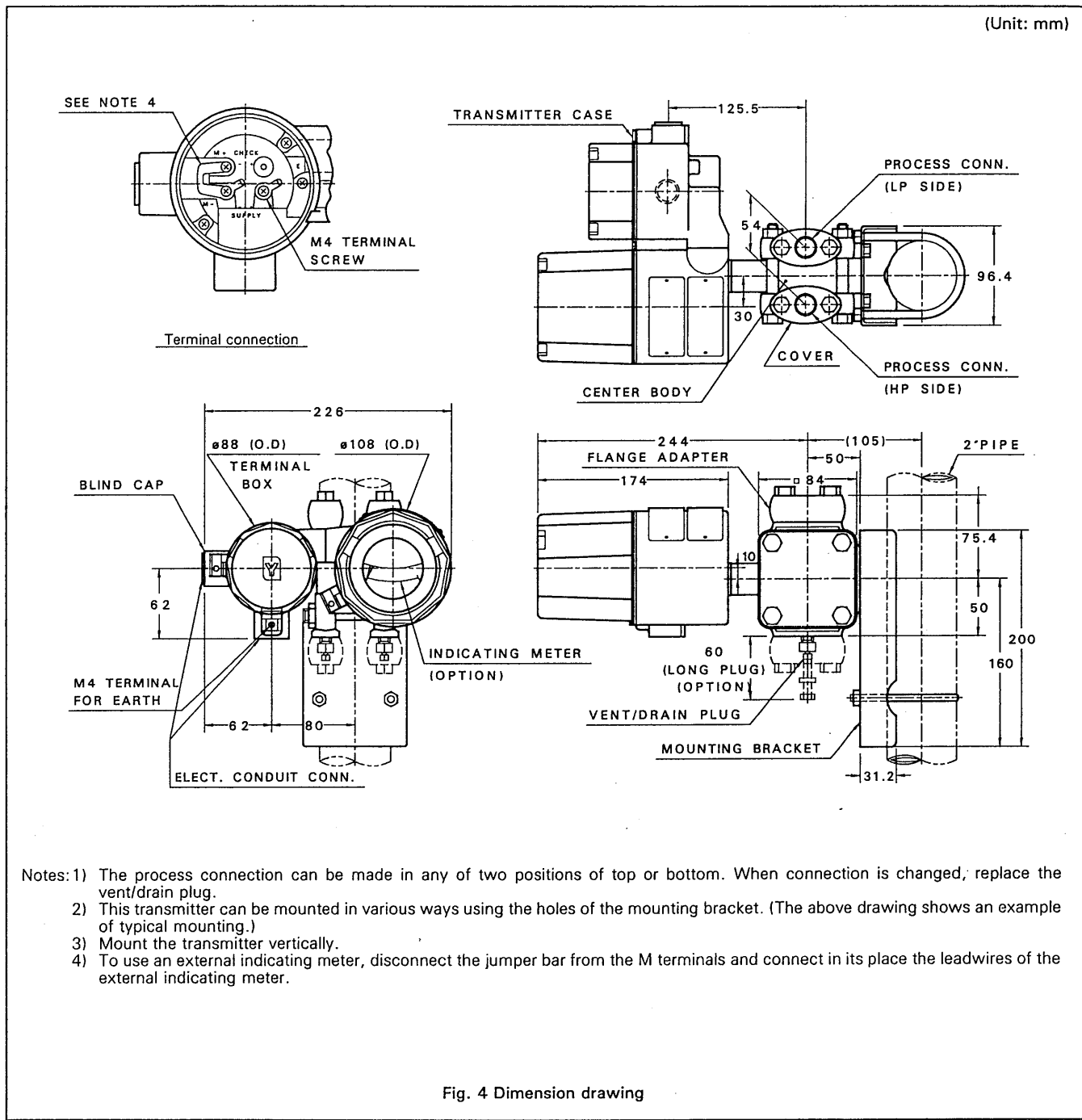
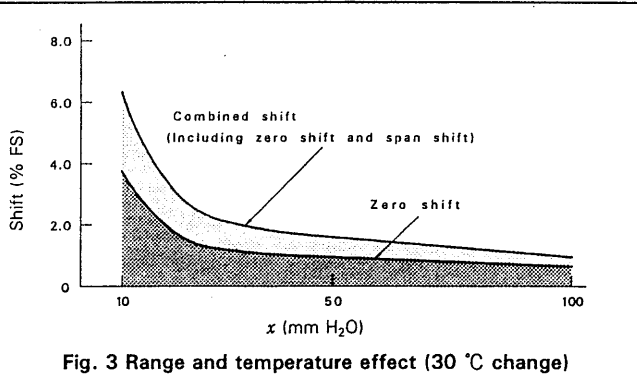

*Specifications are subject to change without notice.