

SPS300 A/B Pressure Sensor/Switch User's Manual



(Wall-mount Type)



(Panel-mount Type)

Thank you for purchasing the SPS300 A/B Pressure Sensor/Switch.

This manual contains information for ensuring correct use of the SPS300 A/B pressure sensors/switches. It also provides necessary information for installation, maintenance, and troubleshooting. This manual should be read by those who design and maintain devices that use the SPS300 A/B pressure sensors/switches.

Be sure to keep this manual near by for handy reference.

Yamatake Corporation

RESTRICTIONS ON USE

This product has been designed, developed and manufactured for general-purpose application in machinery and equipment. Accordingly, when used in applications outlined below, special care should be taken to implement a fail-safe and/or redundant design concept as well as a periodic maintenance program.

- Safety devices for plant worker protection
- Start/stop control devices for transportation and material handling machines
- Aeronautical/aerospace machines
- Control devices for nuclear reactors

Never use this product in applications where human safety may be put at risk.

Contents

	Safety Precautions	i
	Safety Requirements	ii
Chapter 1	GENERAL FEATURES	
1-1	Overview	1-1
1-2	Features	1-1
1-3	Function Outline	1-3
Chapter 2	COMPONENT PART NAMES & OPERATING METHODS	
2-1	Summary	2-2
2-2	Operating Methods	2-3
2-3	Procedures in the DISPLAY/PARAMETER Modes	2-6
Chapter 3	TROUBLESHOOTING	
3-1	Alarm Code Display	3-1
3-2	Troubleshooting Procedure	3-1
Chapter 4	MODEL NUMBER	
4-1	Model Number Configuration	4-1
4-2	Specifications	4-2
4-3	Accessories and Optional Parts	4-6
4-4	External Dimension Drawing	4-7
Chapter 5	INSTALLATION	
5-1	Siting Environment	5-1
5-2	Pressure Inlet Connection	5-2
5-3	Installation	5-3
Chapter 6	WIRING	
Chapter 7	MAINTENANCE	

Safety Precautions

WARNING

- Before wiring, or removing/mounting the SPS300 A/B, be sure to turn the power OFF. Failure to do so might cause electric shock.
- Before connecting the SPS300 A/B to the measurement target or external control circuits, make sure that a protective ground terminal is connected to the SPS300 A/B.

Failure to do so might cause electric shock or fire.

CAUTION

- PV value zero point and full-span point have been adjusted before shipment from the factory. Do not adjust these points again at installation. If these points must be adjusted, compensate by PV bias.
- Wire the SPS300 A/B according to the descriptions on pages 5-1 to 6-6 to ensure that the performance of the SPS300 A/B is fully exhibited.
- Wire the SPS300 A/B according to predetermined standards. Also wire the SPS300 A/B using designated power leads according to recognized installation methods. Failure to do might cause electric shock, fire or faulty operation.
- Use the SPS300 A/B within the operating ranges recommended in the specifications (temperature, humidity, voltage, vibration, shock, atmosphere, etc.). Failure to do so might cause fire or faulty operation.
- Do not disassemble the SPS300 A/B, nor touch components inside the SPS300 A/B. Doing so might cause electric shock or faulty operation
- Do not touch internal components during use or immediately after turning the power OFF. Doing so might cause burns.
- If the SPS300 A/B must be wired via a conduit, provide an appropriate conduit. Also, when the SPS300 A/B must be protected from the rain, provide a water-proof conduit, and properly seal unused conduit holes with plugs (supplied). Failure to do might cause electric shock, fire or faulty operation.
- Do not operate the keys with a propelling pencil or sharp-tipped object. Doing so might cause faulty operation.
- Do not climb on top of the SPS300 A/B nor use the SPS300 A/B as a stand. Doing so might cause faulty operation.

SAFETY REQUIREMENTS



To reduce risk of electrical shock which could cause personal injury, follow all safety notices in this document.



This symbol warns the user of a potential shock hazard where hazardous live voltages may be accessible.



Protective ground terminal. Provided for connection of the protective ground supply system conductor.

- * If the equipment is used in a manner not specified by the manufacturer, the protection provided by the equipment might be impaired.
- * Do not replace any component (or part) not explicitly specified as replaceable by your supplier.
- * All wiring must be in accordance with local standards and carried out by authorized experienced personnel.
- * The protective ground terminal must be connected before any other wiring (and disconnected last).
- * A switch in the main power supply is required within operating range of the equipment.
- * Mains power supply wiring requires a (Type F) 100 mA, 250 V fuse(s) (supply voltage: 100/120 VAC).
- * Mains power supply wiring requires a (Type F) 50 mA, 250 V fuse(s) (supply voltage: 200/240 VAC).

EQUIPMENT RATINGS

Supply voltage	100/200 VAC (SPS300xxxxx1xx) 120/240 VAC (SPS300xxxxx2xx)
Frequency	50/60 Hz
Power consumption	7 W max.

EQUIPMENT CONDITIONS

Do not operate the instrument in the presence of flammable liquids or vapors. Operation of any electrical instrument in such an environment constitutes a safety hazard.

Temperature:	-20 to +60°C
Humidity:	0 to 90% RH/40°C
Vibration:	Frequency 10 to 60 Hz Acceleration 4.9m/s ² maximum
Installation category:	Category II (IEC664-1, EN61010-1)
Pollution degree:	2

EQUIPMENT INSTALLATION

The equipment must be mounted into a panel to limit operator access to the rear terminals.

Specification of common mode voltage: The common mode voltages of 4 to 20 mA output is less than 30 V rms, 42.4 V peak and 60 VDC.

APPLICABLE STANDARDS

EN61010-1, EN50081-2, EN50082-2, EN61326

Chapter 1 GENERAL FEATURES

1-1 Overview

The Pressure Sensor/Switch SPS300A/B is a digital indicating pressure sensor that utilizes solid-state silicon semiconductor pressure elements. It is used to control air, vapor, inert gas and non-corrosive liquid pressures, and to indicate alarms. It is produced in either a wall-mount or panel-mount type.

1-2 Features

① High accuracy

The accuracy for the display and output range, 4 to 20 mA, is $\pm 0.25\%FS$ at 0 to 50°C. It exhibits no temperature characteristics.

② Pressure readings

Pressure values (PV value) are indicated by a 4-digit, 7-segment LED. The position of the decimal point can be moved to a minimum resolution range.

③ 4 to 20 mA output

PV values are converted to 4 to 20 mA output for either full range or a preset span.

④ Relay contact output

Relay ON/OFF control is carried out by contacts according to the digital settings below.

⑤ Digital settings (set point, differential)

Relay contact and pressure differential set points can be input by key input while monitoring process pressures (digital readings and set points can be checked as needed).

⑥ Keylock

The DISPLAY and PARAMETER mode details can be displayed and checked in the keylock state. However, these modes cannot be set. This prevents inadvertent and erroneous setting.

⑦ Display digit

The display digit can be changed so that the lowermost digit is hidden. This prevents flickering on the display caused by small pressure fluctuations.

⑧ Peak hold

The previous maximum pressure value can be stored to memory and checked when required. This value is cleared when the power supply is turned OFF.

⑨ Filter time constant change

Sudden fluctuations in PV value can be suppressed by the preset time constant.

⑩ HI/LO operation switching

The excitation direction of the relay can be changed as follows.

HI Relay de-excited on pressure rise, excited on pressure drop.

LO Relay excited on pressure rise, de-excited on pressure drop.

The operation LED lights when the relay is excited.

⑪ PV bias

Process variables can be increased or decreased with preset values. This allows zero point adjustment to atmospheric pressure.

⑫ PV adjusting values (zero point, span point)

Zero and span point of PV values are adjustable.

⑬ Current value manual output (SPS300A)

Manually set pressure values can be output in order to check controllers and recorders during trial runs. (Relay control also is carried out.)

⑭ Self-diagnostics

Abnormal conditions are monitored by an integral microcomputer so that remedial measures can be quickly carried out.



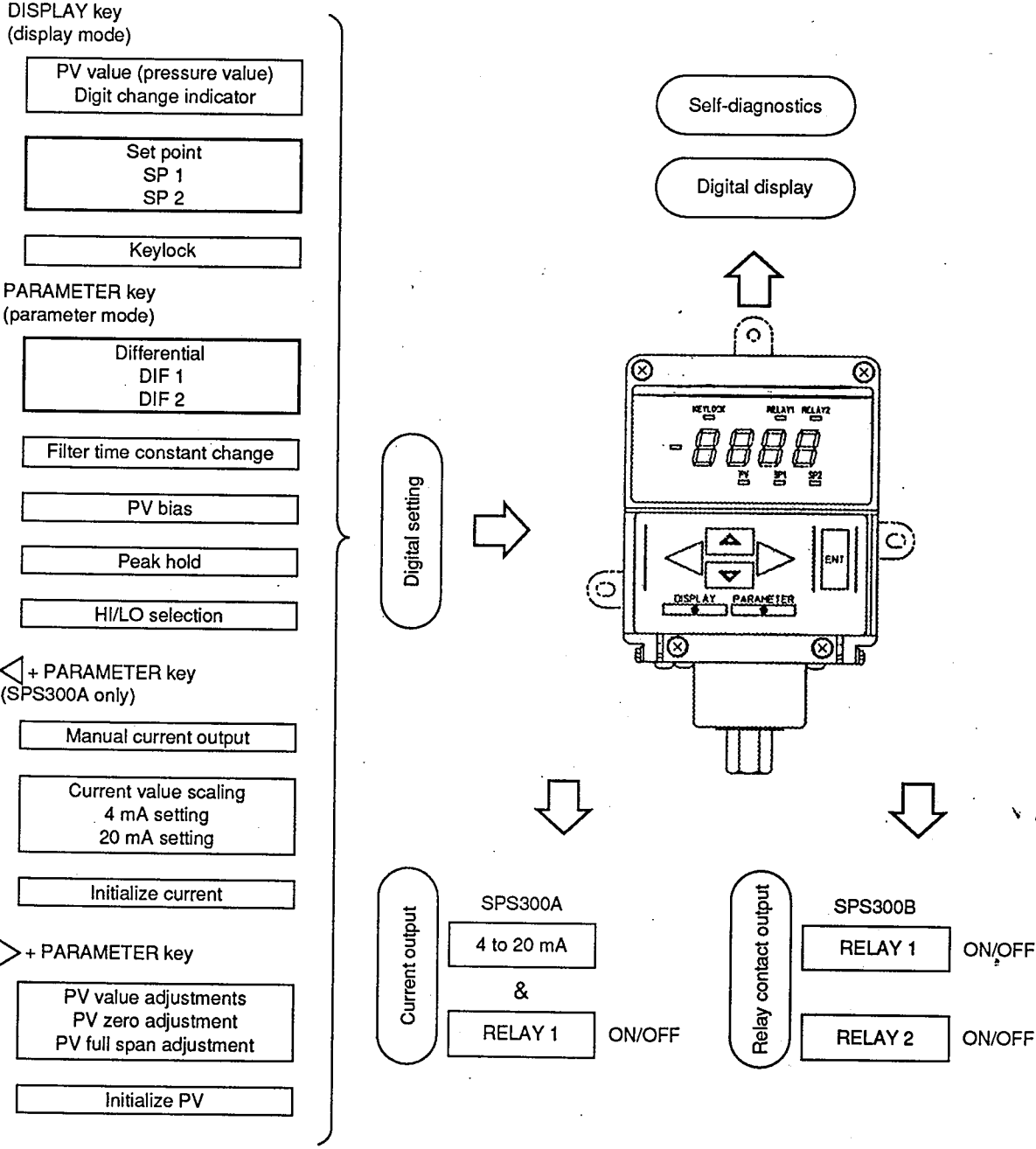

1-3 Function Outline

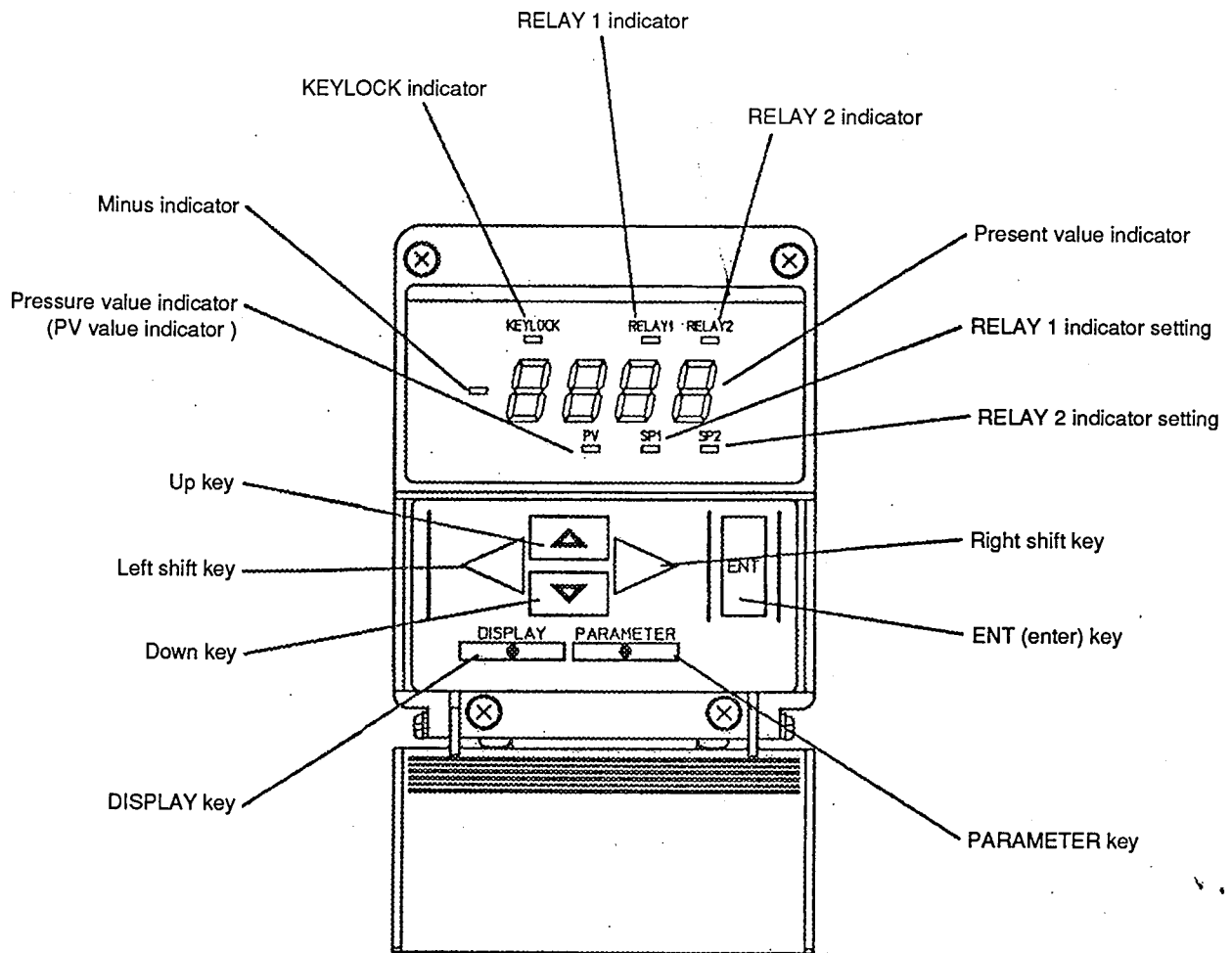







Chapter 2 COMPONENT PART NAMES & OPERATING METHODS



■ Entering numerical values with the DISPLAY key:

- Move the digit to the left or right with the  keys, and increment or decrement the value with the  or  keys.
- Key in the values, and press the  key.

■ Entering numerical values with the PARAMETER key:

- Press the  key.
- Move the digit to the left or right with the  or  keys, and increment or decrement the value with the  or  keys.
- Press the  key.

2-1 Operating Summary







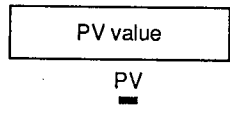

Key Operation	Mode	Function	SPS300A	SPS300B	Display Characters and Lamp States
DISPLAY key	① DISPLAY mode	PV value display	○	○	PV lamp lit
		SP1 value setting	○	○	SP1 lamp lit
		SP2 value setting	x	○	SP2 lamp lit
		Keylock	○	○	LOCK (LOCK)
PARAMETER key	② PARAMETER mode	DIFF1 value setting	○	○	DI.F1 (DI. F1)
		DIFF2 value setting	x	○	DI.F2 (DI. F2)
		Digital filter time constant setting	○	○	FILT (FILT)
		PV bias value setting	○	○	BIAS (BIAS)
		Peak hold value display	○	○	PEAK (PEAK)
		Relay 1 action state setting	○	○	REL1 (REL 1)
		Relay 2 action state setting	x	○	REL2 (REL 2)
◀ + PARAMETER key	③ 4 to 20 mode	4 to 20 mA manual output (relay control function provided)	○	x	MANAL (MANUAL)
		4 mA output point range scaling value setting	○	x	4AD (4 AD)
		20 mA output point range scaling value setting	○	x	20AD (20 AD)
		4 to 20 mA output values initialization	○	x	CUIA (CURRENT INITIALIZE)
▶ + PARAMETER key	④ PV adjustment mode	PV zero adjusting value setting	○	○	PV0 (PV 0)
		PV span adjusting value setting	○	○	PVFS (PV FULL SCALL)
		PV all adjusting value initialization	○	○	PVIA (PV INITIALIZE)

(Note) Press ◀ + PARAMETER, ▶ + PARAMETER key first, then PARAMETER key.

2-2 Operating Methods

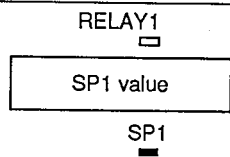

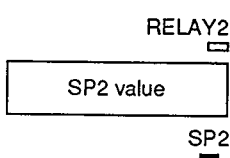

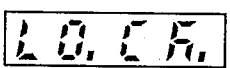





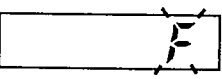

DISPLAY key operation

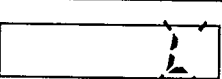
(1) Each press of the DISPLAY key sequentially accesses the following functions.

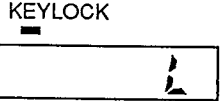
Step	Key Operation	Display	Description
1	Press  key		PV value display PV LED lights. To shift display digit, press  or  key. Fix display digit with ENT key.
2	Press  key		SP1 value display SP1 LED lights. RELAY 1 RED lights when relay 1 is excited. Settin range: Within the Display/Setting range of Table 1
3	Press  key		(Note) SPS300B only SP2 value display SP2 LED lights. RELAY 2 LED lights when relay 2 is excited. Settin range: Within the Display/Setting range of Table 1
4	Press  key		LOCK display Keylock setting is ready.



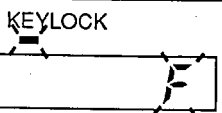

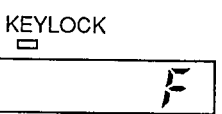

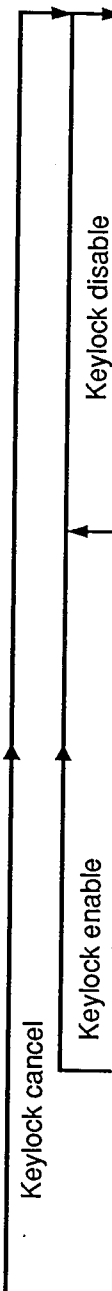



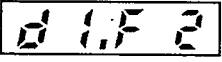

- The RELAY LED lights when the relay is excited.
- The lighting direction of the RELAY LED will change according to the HI/LO setting.

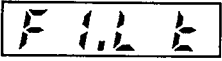
When the keylock is enabled and canceled

5	Press  key		 Display blinks. (F=Free)
6	Press either  or  key		 Display blinks. (L=LOCK)
7	Press  key		 Display KEYLOCK LED lights. Keylock setting
8	Press either  or  key		 Display blinks. KEYLOCK LED blinks.
9	Press  key		F display KEYLOCK LED goes out. Keylock canceled.







PARAMETER key operation

Step	Key Operation	Display	Description
1	Press  key	= 	Differential 1 value setting Setting range: Within the Display/Setting range of Table 1, for the positive figure excluding zero
2	Press  key	= 	(SPS300B only) Differential 2 value setting Setting range: Within the Display/Setting range of Table 1, for the positive figure excluding zero
3	Press  key	= 	Digital filter time constant Setting range: 0.00 to 99.99 s
4	Press  key	= 	PV bias value setting Setting range: Within the Display/Setting range of Table 1
5	Press  key	= 	Peak hold value display
6	Press  key	= 	Relay 1 action state setting
7	Press  key	= 	(SPS300B only) Relay 2 action state setting



Operation by simultaneously pressing the ◀ + PARAMETER keys

This is displayed only on the SPS300A.

Step	Key Operation	Display	Description
1	Press ◀ +  key	= 0.000	4 to 20mA manual output (relay control function provided.) Settin range: Within the Display/Setting range of Table 1
2	Press  key	= 4 Ad	4mA output point range scaling value setting Setting range: Within the Display/Setting range, with less than 20mA output point range scaling value
3	Press  key	= 20 Ad	20 mA output point range scaling value setting Setting range: Within the Display/Setting range, with more than 4 mA output point range scaling value
4	Press  key	= 0.00	4 to 20 mA output values initialization Factory settings are re-stored.

Operation by simultaneously pressing the ▶ + PARAMETER keys



Refer to items [4-1], [4-2] and [4-3] before carrying out this operation. (pages 2-12 and 2-13)



Step	Key Operation	Display	Description
1	Press ▶ +  key	= Pv 0	PV zero adjusting value setting
2	Press  key	= Pv FS.	PV span adjusting value setting
3	Press  key	= Pv 0.0	PV all adjusting value initialization Factory settings are re-stored.

2-3 Procedures in the DISPLAY/PARAMETER Modes

[1] Display mode

[1-1] PV function/display digit change function (PV)

- Entering the DISPLAY mode
 - 1) After one second, the PV lamp lights, and the measured pressure value (PV value) is displayed.
 - 2) Pressing the  key allows the PV function to be changed from other modes.
 - 3) Pressing the  key in a keylock state sets the PV function.

- Exiting the DISPLAY mode
 - 1) Pressing the  key changes the function from PV to SP1.
 - 2) Pressing the  key enters the PARAMETER mode.

The display changes to *d i . F i*.

- Description
 - 1) The PV value is displayed, and the PV LED lights.
 - 2) To change the display digit (with keylock disabled)
 - Set PV to the desired number of digits with the ◀ or ▶ keys.
 - The display digit cannot be shifted to the right when the decimal point is at the rightmost position (4th digit) by the ◀ key.
 - Alternatively, the display digit can be shifted only to the left by the ▶ key to the position where the full-span value is the most significant digit.
 - Values lower than the display digit are rounded to the nearest whole number.
 - 3) The display digit is set and fixed with the  key.

The display digit will return to its default, if the  key is not pressed before the power is turned OFF.

[1-2] SP1 or SP2 function (SP1), (SP2)

- The procedure for entering and exiting functions is the same as that described on the previous page.
- Description
 - 1) Setting method
 - Select the digit to be set by pressing the ◀ or ▶ key. The blinking digit can be set.
 - Set the desired value by pressing the ▲ or ▼ keys. Each press of the ▲ or ▼ keys increments or decrements the value. Pressing the ▲ key when “9” is indicated changes the value to “0”, and next higher digit is incremented by “1”. Pressing the ▼ key when “0” is indicated changes the value to “9”, the next higher digit is decremented by “1”.
 - When you press the ENT key after setting to the desired numerical value, the digit blinks once, and then stops blinking to indicate that the value has been set. Control output is also executed at the same time.
 - To reset the value, press the ◀, ▶, ▲ or ▼ keys.

NOTE

- Since the next displayed digit on the PV display has been rounded to the nearest whole number, the corresponding relay may not function even if the same value is displayed for the set point and PV value.
- This is more likely to happen when the PV value digit has been moved.
- The relay functions when the PV value after internal operation matches the set point.

[2] PARAMETER mode

[2-1] Differential (d1, F1), (d2, F2)

- The procedure for entering and exiting functions is the same as that in [1-2].

- Description

- 1) Setting method

Pressing the key displays a set point. Repeat the procedures described in [1-2].

[2-2] Filter time constant display/setting function (F1, L1)

- 1) Definition of filter time constant set point

Pressing the key displays a set point.

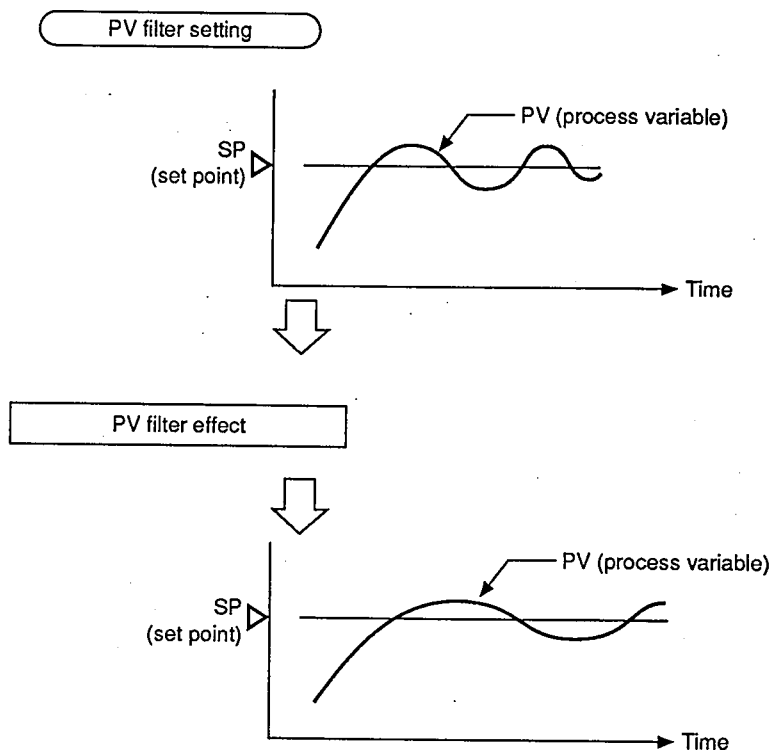

- (1) This item is for setting the PV filter time constant.
 - (2) The "PV filter" suppresses sudden changes in PV (input). Setting this item to "0.0" disables the filter. The higher this value is set, the more effective the PV filter becomes.
- 2) Setting method

Repeat the procedure described in [1-2].

[2-3] PV bias function (b / . R S.)

1) Definition of PV bias set point

Pressing the key displays a set point.

The PV value is displayed or output as a 4 to 20 mA signal after being biased by the set point.

NOTE In the PV adjustment mode

Since the PV bias function is independent, it remains unchanged if either PV zero point or PV full-span point values are adjusted.

2) Setting method

Repeat the procedure described in [1-2].

[2-4] Peak hold display/setting function (P E R S.)

1) Setting method

Pressing the key displays the last maximum pressure value. (This value is cleared when the power supply is turned OFF.)

2) Clear procedure

Pressing the key causes the **5. G.** (GO) display to blink.

Pressing the key again clears the display, and updates the peak hold value.

3) Display cautions

Zero will be displayed for 20 seconds when the power supply is turned ON.

NOTE

Values exceeding the rated pressure should only be used as a reference, since readout accuracy decreases by about $\pm 5\%$.

Also, drift in readout accuracy may occur if a pressure exceeding the rated pressure is applied.

[2-5] Relay 1 or 2 action state selection (H I), (L O)

- 1) H I is displayed in the relay 1 function mode, while L O is displayed in the relay 2 function mode.
- 2) Pressing the key de-excites the corresponding relay as follows:
 - If input is greater than the set point during H I, pressure increase, the relay is de-excited (pressure rise control).
 - If input is less than set the point during L O, pressure decrease, the relay is de-excited (pressure drop control).
- 3) Pressing the or keys reverses the setting state. Pressing the key loads and displays set points.

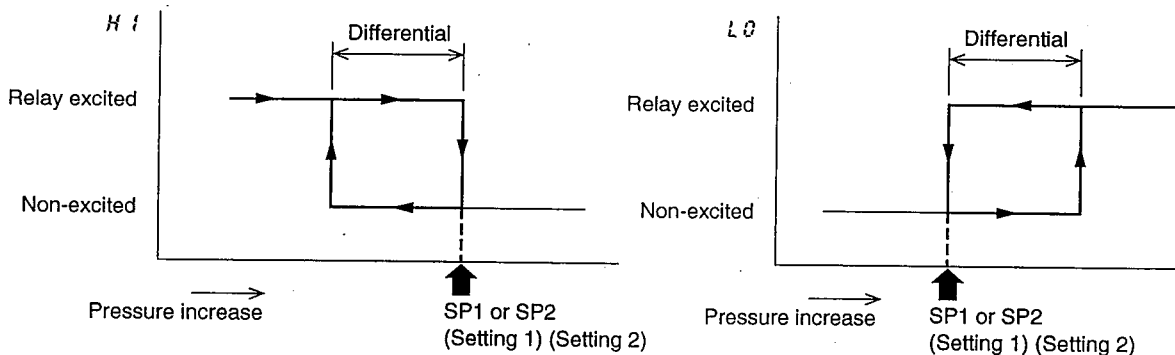

- 4) The operation LED lights when the relay is excited.

[3-1] Current value manual output function (P, R R L)

- 1) Setting method
 - Pressing the key displays and outputs the current PV value. Set the PV value to be output with the , , , or keys, then press the key. The new setting value is displayed and output.

[3-2] 4 mA output point range scaling (4 R d)





- Description
 - 4 R d is displayed in the 4Ad function mode.
 - Pressing the key displays the value at the 4 mA output point.
- 1) Setting method
 - Input a desired value for the 4 mA output point by the , , , keys.
 - Pressing the key displays the new setting value.
 - The 4 to 20 mA process variables are also changed as a result of the above change.

[3-3] 20 mA output point range scaling (20Rd)

• Description

- 20Rd is displayed in the 20Ad function mode.
- Pressing the  key displays the value at the 20 mA output point.



1) Setting method

- Input a desired value for the 20 mA output point by the , , ,  keys.
- Pressing the  key displays the new setting value.
- The 4 to 20 mA process variables are also changed as a result of the above change.

[3-4] 4 to 20 mA output values initialization (4U1.n)

- 4U1.n is displayed in the initialize function mode.

1) Setting method

- Pressing the  key causes 4U1.n to blink.
- Pressing the  key again in this state resets the 4 to 20 mA output to the factory setting.
- This function is effective when resetting the 4 to 20 mA output value to the default if the adjustment has failed in [3-2] or [3-3].

Note

- **PV value zero point and full-span point have been adjusted** before shipment from the factory. **Do not adjust these points** again at installation. If these points must be adjusted, compensate by PV bias.
- When adjusting the zero point and full-span point during maintenance and inspection, or calibration, follow the descriptions described below.
- **If adjustment is not successful** after carrying out [4-1] and [4-2], initialize the settings following the description in [4-3].

[4-1] PV zero point adjustment function (P or Q)

1) Setting method

Pressing the $\boxed{\text{ENT}}$ key displays the current PV value (PV value based on the factory set point but excluding bias value).

2) • Set the pressure to either zero or a fixed value.

- Enter the numerical value indicated on the reference manometer by the \triangleleft , \triangleleft , \triangleleft , \triangleright keys.
- Pressing the $\boxed{\text{ENT}}$ key calculates and displays the current PV value so that it is matched to the input value.
- The difference between PV and input values is calculated in order to change the bias and ratio of the subsequent PV value.
- The following figure illustrates the relationship caused by this adjustment.

$$Y = \frac{B - A}{b - a} (X - a) + A$$

$$= \frac{B - A}{b - a} X - \frac{a(B - A)}{b - a} + A$$

Adjusting bias value

where,

X = Value after adjustment

Y = Value before adjustment

A, B: Value after adjustment

a, b: Value before adjustment

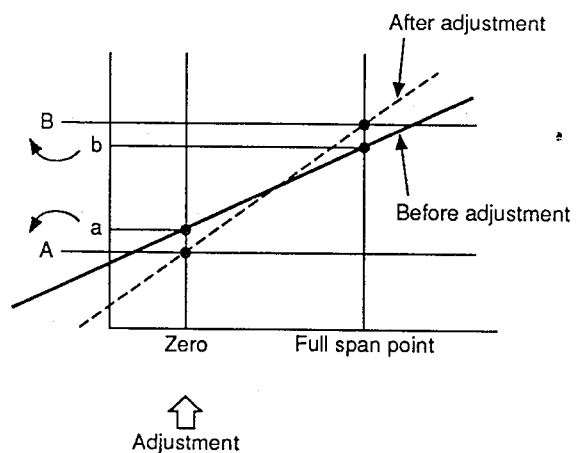

- To reset, repeat the above procedure.
- The 4 to 20 mA process variables are also changed as a result of the above adjustment.

NOTE

- Since the PV bias value is not adjusted, reset it to zero before carrying out the above adjustment.
- An adjusting bias value after PV zero adjustment is independent of PV bias values.
- Reset the filter time constant to zero and adjust it after the PV value has stabilized.

[4-2] PV value full-span point adjustment (P v F S.)

1) Setting method

Pressing the $\boxed{\text{ENT}}$ key displays the current PV value (PV value based on the factory set point but excluding bias value).

2) Supply full-span pressure until it stabilizes.

- Enter the numerical value indicated on the reference manometer by the \triangleleft , \triangleright , \triangle , ∇ keys.
- Pressing the $\boxed{\text{ENT}}$ key calculates and displays the current PV value so that it is matched to the input value.

NOTE

- Since the PV bias value is not adjusted, reset it to zero before carrying out the above adjustment.
- Reset the filter time constant to zero and adjust it after the PV value has stabilized.
- After adjusting the PV value zero point, be sure to press the $\boxed{\text{DISPLAY}}$ key to check the PV value.

$$Y = \frac{B - A}{b - a} (X - a) + A$$

$$= \frac{B - A}{b - a} X - \frac{a(B - A)}{b - a} + A$$

Adjusting bias value

where,

- Y = Value after adjustment
- X = Value before adjustment
- A, B: Value after adjustment
- a, b: Value before adjustment

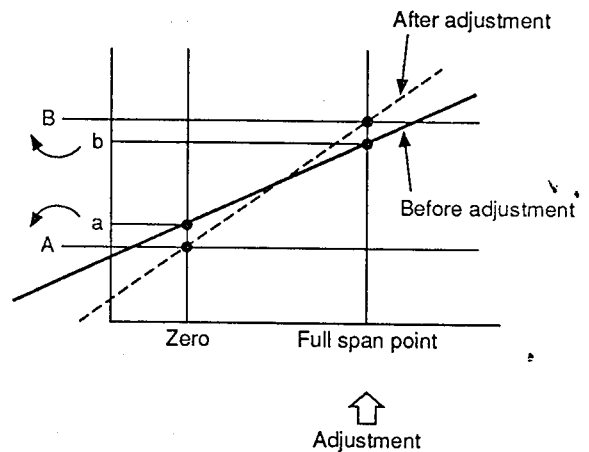

[4-3] PV value zero point and full-span point adjustment initialization (P v I . n)

- P v I . n is displayed in the initialize function mode.

1) Setting method

- Pressing the $\boxed{\text{ENT}}$ key causes δ , σ to blink.
- Pressing the $\boxed{\text{ENT}}$ key again in this state resets the PV value adjustment to the factory setting.
- This function is effective when adjusting the PV value zero point and full-span point to the defaults if the adjustment has failed in [4-1] or [4-2].

Chapter 3 TROUBLESHOOTING

3-1 Alarm Code Display

Alarm Code	Cause of Alarm	Corrective Measures
ALr1	Excessive pressure (Application of pressure lower than the Display/Setting range of Table 1)	Apply rated pressure and confirm normal operation.
ALr2	Excessive pressure (Application of pressure higher than the Display/Setting range of Table 1)	Apply rated pressure and confirm normal operation.
ALr3	Lower than -20°C (inside case)	Check operation in recommended temperature range.
ALr4	Higher than 80°C (inside case)	Check operation in recommended temperature range.
ALr5	User setting memory error	Check all setting values and reset if necessary.
ALr6	Factory setting memory error	Ask for repair

- PV values and alarm codes are alternately displayed.
- Outputs in this state are not guaranteed as normal.

3-2 Troubleshooting Procedure

(1) PV value not displayed.

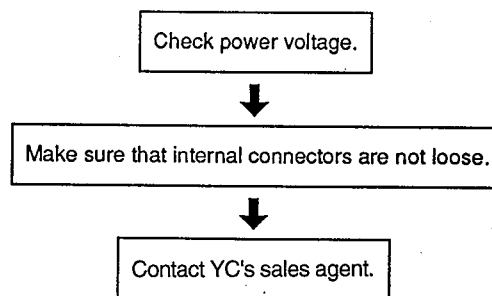

(2) PV value error

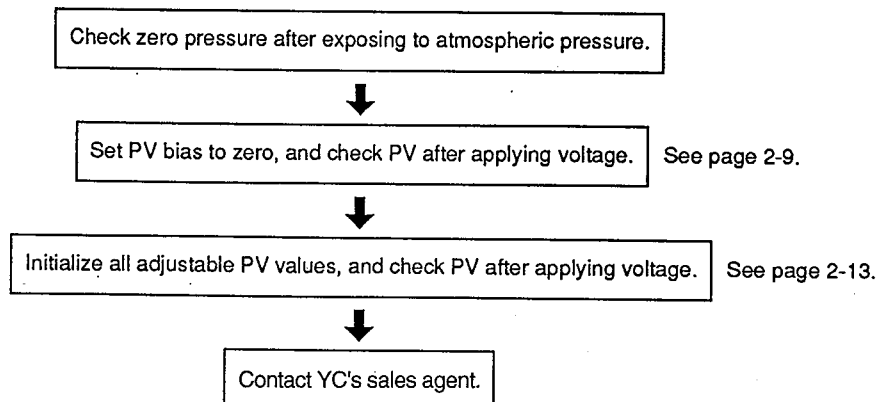

(3) 4 to 20 mA error

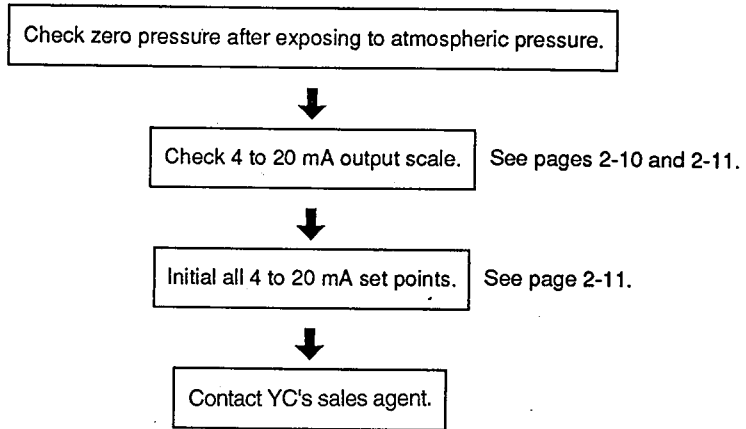

(4) Incorrect operation

