

# ST3000 Series 900 Smart Transmitter

## Remote-sealed type of Pressure Transmitters

### Model STU940

#### **OVERVIEW**

The ST3000 Smart Transmitter is a microprocessor-based smart transmitter that features high performance and excellent stability. Capable of measuring gas, liquid, and vapor pressures, and liquid levels, it transmits 4 to 20 mA DC analog and digital signals according to the measured differential pressure.

It can also execute two-way communications between the SFC (Smart Field Communicator) or HART<sup>®</sup> 275 communicator, and, via DE protocol, with the TDCS3000 or 3000<sup>X</sup> and a database, thus facilitating self-diagnosis, range resetting, and automatic zero adjustment.

Remote-sealed pressure transmitters are suitable for the measurement of process fluid pressures (pressures, oil levels, etc.) of process fluids that are highly corrosive, tend to condense, precipitate metal, etc.



#### **FEATURES**

##### **Excellent stability and high performance**

- Long-term stability is proven in 500,000 installations worldwide.
- Unique characterization and composite semiconductor sensors realize excellent temperature and static pressure characteristics.

##### **A diverse lineup**

- A diverse flange lineup, ranging from small diameter 1.5 inch (40 mm) and 2 inches (50 mm) to 3 inches (80 mm), is available to meet user requirements.
- A wide variety of corrosion-resistant materials for wetted parts is also available.

##### **Function to correct the temperature of the fill fluid of the capillary section**

Changes in the density of the fill fluid caused by temperature fluctuations are calculated, and the output is corrected accordingly. This function substantially reduces (to 1/5 - 1/10) the effect of seasonal fluctuations in temperature.

##### **Remote communication**

- Either analog output (4 to 20 mA DC), or digital output (DE protocol) is possible.
- Two-way communication using digital output facilitates self-diagnosis, range resetting, automatic zero adjustment, and other operations.
- HART<sup>®</sup> protocol communication is available. (Option)

HART<sup>®</sup> is a registered trademark of the HART Communication Foundation.

**APPLICATION**

**Petroleum / Petrochemical / Chemical**

For the measurement of liquid levels including corrosive fluids at high temperatures, and high temperatures under vacuum

**Electric power / City gas / Other utilities**

For measurement applications that require high degrees of stability and accuracy.

**Pulp and paper**

For lines that need transmitters resistant to chemical liquids, corrosive fluids and the like.

**Iron and steel / Nonferrous metal / Ceramics**

For lines that require stable measurement under strictly controlled (temperature, humidity, etc.) conditions.

**Machinery / Shipbuilding**

For lines that require stable measurement under strictly controlled (temperature, humidity, vibration, etc.) conditions.

**FUNCTIONAL SPECIFICATIONS**

**Type of protection**

JIS C0920 watertight: NEMA3 and 4X  
JIS F8001 class 2 watertight: IEC IP67

**FM Explosionproof approval**

**Explosionproof** for Class I (Gas, steam), Division 1, Group A, B, C, D

**Dust-ignition** for Class II (Inflammable dust), Division 1, Group E, F, G

**Suitable** for Class III (inflammable fiber), Division 1  
**Nonincendive** for Class I, Division 2, Group A, B, C, D

**FM Intrinsically safe approval**

**Intrinsically safe** for Class I, II, III, Division 1, Group A, B, C, D, E, F, G

**ATEX Flameproof approval**

Certificate number: INERIS99ATEX0010 X

**Ex** II 2 GD EExd IIC T6 at  $-20 \leq T_{amb} \leq +60^{\circ}C$

**ATEX Intrinsic safety**

Certificate number: KEMA03ATEX1225 X

**Ex** II 1 G EEx ia IIC T4 at  $-20 \leq T_{amb} \leq +60^{\circ}C$

Electrical data:  $U_i = 30V$   
 $I_i = 100 mA$   
 $P_i = 1W$   
 $C_i = 3 nF$   
 $L_i = 0.5 mH$

**SPECIAL CONDITIONS FOR SAFE USE (X)**

Because the enclosure of the Smart Pressure Transmitter is made of aluminium, if it is mounted in an area where the use of category 1 G apparatus is required, it must be installed such, that, even in the event of rare

incidents, ignition sources due to impact and friction sparks are excluded.

**NEPSI Flameproof approval**

Ex d II T6 (with NEPSI Dust Ignition DIP DT T13)

**NEPSI Intrinsically safe approval**

Ex ia IIC T5 at  $-20 \leq T_{amb} \leq +60^{\circ}C$   
Ex ia IIC T6 at  $-20 \leq T_{amb} \leq +40^{\circ}C$

**CSA Explosion-proof Approval**

**CSA Explosion-proof** for Class I, (Division 1), Groups A, B, C and D

**CSA Flameproof** for Class I, Zone 1, Ex d IIC T6 at ambient temp. =  $-20^{\circ}C$  to  $+60^{\circ}C$

**CSA Dust-ignitionproof** for Class II and III, (Division 1), Groups E, F and G

**EMC Conformity**

89/336/EEC, 92/31/EEC, 93/68/EEC Electromagnetic Compatibility (EMC) Directive

**PED Conformity (97/23/EC)**

Comply with Module H (with "H1" option), or SEP (Sound Engineering Practice) for models of which maximum working pressure is 200 bar or lower.

**Measuring span / Setting range / Working pressure range**

	Measuring span	Setting range	Working pressure range	Overload resistant value
STU 940 R5	4 to 104 kPa abs. {30 to 780 mmHg abs.}	0 to 104 kPa {0 to 780 mmHg abs.}	0.13 to 104 kPa abs.	300 kPa abs. {3.0 kgf/cm <sup>2</sup> }
STU 940 R6	35 to 3500 kPa abs. {0.35 to 35 kgf/cm <sup>2</sup> abs.}	0 to 3500 kPa abs. {0 to 35 kgf/cm <sup>2</sup> abs.}	Up to flange rating of the setting range, which is lower.	5250 kPa abs. {52.5 kgf/cm <sup>2</sup> }

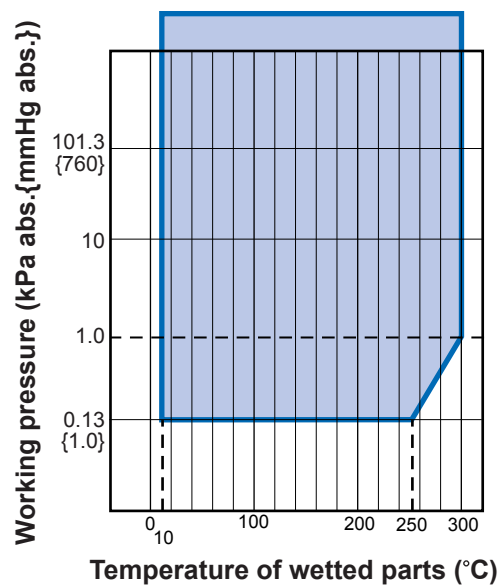
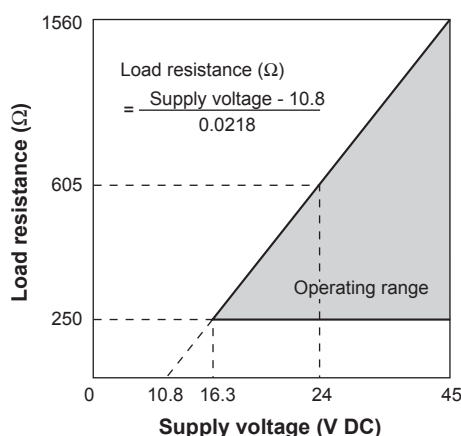

Figure 1 Working pressure and temperature of wetted parts section

## Supply voltage and load resistance

10.8 to 45 V DC. A load resistance of 250 Ω or more is necessary between loops. See Figure 2.



**Figure 2** Supply voltage vs. load resistance characteristics

*Note* For communication with SFC, a load resistance of 250 Ω or more is necessary.

For ATEX Intrinsic safety model, minimum voltage of 18.0V is required.

## Output

Analog output (4 to 20 mA DC) with DE protocol

Analog output (4 to 20 mA DC) with HART protocol

Digital output (DE protocol)

## Ambient temperature limits / Temperature ranges of wetted parts

		Temperature Range (°C) *1 *4
		High-temp. high-vacuum models
Wetted parts section	Normal operating range	10 to 300 *5
	Operative limit range	-10 to 310 *6
Ambient temperature *2	Normal operating range	10 to 55
	Operative limit range	-10 to 60
Specific gravity of fill fluid *3		1.09

*Note* \*1. See the working pressures and temperatures of the wetted parts section in Figure 1.

\*2. Ambient temperatures of the transmitter itself

\*3. Approximate values at the temperature of 25°C

\*4. Note that if the operating temperature falls below the lower limit of the normal operating range, the response of the transmitter becomes slower.

\*5. When the wetted parts material is tantalum, the upper limit is 180°C.

\*6. When the wetted parts material is tantalum, the upper limit is 200°C.

## Ambient humidity limits

5 to 100% RH

## Stability against supply voltage change

± 0.005% FS/V

## Dead time

Approximately 0.4 sec.

## Damping time

Selectable from 0 to 32 sec. in ten stages

## OPTIONAL SPECIFICATIONS

### Lightning protection

Peak value of voltage surge: 200 kV

Peak value of current surge: 2000A

### Built-in indicating meter

The digital LCD indicator (optional) indicates engineering units and can be set freely between -19999 and 19999 (4.5 digits). For meter calibration, specify the following items when placing your order

- Meter calibration range
- Meter calibration unit
- Linear / Square-root for meter indication

Various kinds of data can be set using the SFC smart

communicator (Ver. 7.1 or later) or HART<sup>®</sup>275 communicator.

### Bolts and nuts materials (for fastening meter body cover)

Carbon steel (SNB7), SUS304, SUS630

### Corrosion-resistant finish

#### Corrosion-resistant finish

Corrosion-resistant paint (Baked acrylic paint), fungus-proof finish

#### Corrosion-proof finish

Corrosion-proof paint (Baked epoxy paint), fungus-proof finish

#### Corrosion-resistant finish (silver paint)

Transmitter case is coated with silver paint in addition to the above corrosion-resistant finish.

### Oil free finish

The transmitter is shipped with oil-free wetted parts.

### External zero/span adjustment function

The transmitter can be easily zero/span adjusted in the field.

### Burnout feature

Choice of three states at abnormal condition

Burnout of output values: None, upper limit, lower limit

### Elbow

This is an adaptor for changing the electrical conduit connection port from the horizontal to the vertical direction, if required by wiring conditions in the field. One or two elbows may be used as needed.

### Conformance to SI units

We deliver transmitters set to any SI units as specified.

**PHYSICAL SPECIFICATIONS****Materials****Fill fluid**

Silicone oil for high-temperature vacuum, and high temperature high-vacuum models

For specific gravity, refer to “Ambient temperature limits / Temperature ranges of wetted parts” on page 3

**Center body**

SUS316

**Transmitter case**

Aluminum alloy

**Meter body cover**

SUSF304

**For Wetted parts****Adapter flange (option)**

Carbon steel (SF440A), SUS304, SUS316, SUS316L

**Finish**

Baked acrylic paint

Housing light beige (Munsell 4Y7.2/1.3)

Cap dark beige (Munsell 10YR4.7/0.5)

**Weight**

Approx. 13.3 kg (STU940)

(Including JIS10K-80A flange and capillary 5 m long)

**INSTALLATION****Electrical connection**

1/2NPT internal thread

**Grounding**

Resistance 100 Ω max.

**Mounting**

Direct mounting on the process side

Using 2-inch pipe mounting brackets: Mount the transmitter on a horizontal or vertical 2-inch pipe

**Bracket**

Carbon steel

**U-bolt and nuts**

SUS304

**Process connection****Measured pressure (liquid side)**

Flanges (both higher and lower pressure sides)

**Flush diaphragm**

JIS10K, 20K and 30K: 80 mm (RF) equivalents

ANSI 150 and 300: 3 inches (RF) equivalents

JPI 150 and 300: 3 in (RF) equivalents

**Extended diaphragm**

JIS10K, 20K and 30K: 100 mm (RF) equivalents

ANSI 150 and 300: 4 inches (RF) equivalents

JPI 150 and 300: 4 in (RF) equivalents

**Wafer**

2 inches wafer (RF) equivalent

**Screw connection**

G1½ button diaphragm (G1½ external thread)

**Mounting notes****For pressure measurement**

- 1) If the fluid to be measured contains hydrogen, please consult us.
- 2) When mounting the transmitter, leave a space of at least 10 cm under the upper nozzle of the tank. If the no space is available, please consult us.

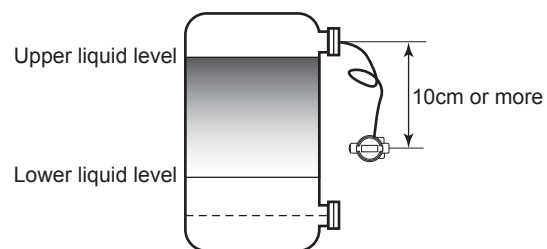

**PERFORMANCE SPECIFICATIONS**

**Max working pressure**

- Note) 1. Max working pressure depends on flange rating, flange materials and operating temperature. Please refer to the following data. Operating range of temperature depends on specification of transmitters.  
 2. In case of flange type (model STC940□) and remote scaled type (model STU940□, model STH940□), max working pressure depends on the smaller value of either 1.5 MPa or following data.  
 3. In case of remote scaled type (model STH960□), max working pressure depends on the smaller value of either 10 MPa or following data.

	JIS	JPI/ANSI
<b>Carbon steel</b>		
<b>SUS304</b>		
<b>SUS316</b>		
<b>SUS316L</b>		

**Accuracy**

Shown for each item are the percentage ratio for  $\chi$  (kPa), which is the greatest value of either the upper range value (URV)<sup>\*1</sup>, the lower range value (LRV)<sup>\*2</sup> or the span.

**Model STU940 (R5) (for high-temperature high-vacuum service)**

Material of wetted parts: SUS316 (Diaphragm: SUS316L)

Accuracy		$\pm 0.25\%$	(For $\chi \geq 12$ kPa abs. (90 mmHg abs.))
		$\pm (0.1 + 0.15 \times \frac{12}{\chi})\%$	(For $\chi < 12$ kPa abs. (90 mmHg abs.))
Temperature characteristics (Shift from the set range) Change of 30°C	Zero shift	$\pm (0.14 + 0.52 \times \frac{12}{\chi})\%$	$\chi$ : kPa abs.
	Combined shift	$\pm 0.79\%$	(For $\chi \geq 12$ kPa abs. (90 mmHg abs.))
		$\pm (0.19 + 0.6 \times \frac{12}{\chi})\%$	(For $\chi < 12$ kPa abs. (90 mmHg abs.))

**Model STU940 (R5) (for high-temperature high-vacuum service)**

Material of wetted parts: Hastelloy C, Tantalum, SUS316L

Accuracy		$\pm 1.05\%$	(For $\chi \geq 12$ kPa abs. (90 mmHg abs.))
		$\pm (1.05 \times \frac{12}{\chi})\%$	(For $\chi < 12$ kPa abs. (90 mmHg abs.))
Temperature characteristics (Shift from the set range) Change of 30°C	Zero shift	$\pm 1.08\%$	(For $\chi \geq 12$ kPa abs. (90 mmHg abs.))
		$\pm (1.08 \times \frac{12}{\chi})\%$	(For $\chi < 12$ kPa abs. (90 mmHg abs.))
	Combined shift	$\pm 1.29\%$	(For $\chi \geq 12$ kPa abs. (90 mmHg abs.))
		$\pm (1.29 \times \frac{12}{\chi})\%$	(For $\chi < 12$ kPa abs. (90 mmHg abs.))

**Model STU940 (R6) (for high-temperature high-vacuum service)**

Material of wetted parts: SUS316 (Diaphragm: SUS316L)

Accuracy		$\pm 0.25\%$	(For $\chi \geq 350$ kPa abs. (3.5 kgf/cm <sup>2</sup> abs.))
		$\pm (0.1 + 0.15 \times \frac{350}{\chi})\%$	(For $\chi < 350$ kPa abs. (3.5 kgf/cm <sup>2</sup> abs.))
Temperature characteristics (Shift from the set range) Change of 30°C	Zero shift	$\pm (0.14 + 0.52 \times \frac{350}{\chi})\%$	$\chi$ : kPa abs.
	Combined shift	$\pm 0.79\%$	(For $\chi \geq 350$ kPa abs. (3.5 kgf/cm <sup>2</sup> abs.))
		$\pm (0.19 + 0.6 \times \frac{350}{\chi})\%$	(For $\chi < 350$ kPa abs. (3.5 kgf/cm <sup>2</sup> abs.))

**Model STU940 (R6) (for high-temperature high-vacuum service)**

Material of wetted parts: Hastelloy C, Tantalum, SUS316L

Accuracy		$\pm 1.05\%$	(For $\chi \geq 350$ kPa abs. (3.5 kgf/cm <sup>2</sup> abs.))
		$\pm (1.05 \times \frac{350}{\chi})\%$	(For $\chi < 350$ kPa abs. (3.5 kgf/cm <sup>2</sup> abs.))
Temperature characteristics (Shift from the set range) Change of 30°C	Zero shift	$\pm 1.08\%$	(For $\chi \geq 350$ kPa abs. (3.5 kgf/cm <sup>2</sup> abs.))
		$\pm (1.08 \times \frac{350}{\chi})\%$	(For $\chi < 350$ kPa abs. (3.5 kgf/cm <sup>2</sup> abs.))
	Combined shift	$\pm 1.29\%$	(For $\chi \geq 350$ kPa abs. (3.5 kgf/cm <sup>2</sup> abs.))
		$\pm (1.29 \times \frac{350}{\chi})\%$	(For $\chi < 350$ kPa abs. (3.5 kgf/cm <sup>2</sup> abs.))

Note) \*1: URV denotes the process value for 100% (20 mA DC) output

\*2: LRV denotes the process value for 0% (4 mA DC) output.

\*3: Within a range of URV  $\geq 0$  and LRV  $\geq 0$ .

**MODEL SELECTION****ST3000 series 900 electric differential pressure transmitter****Model STU940 (remote-sealed diaphragm type for absolute pressure)**

Model No.: STU940 - I II III IV V VI VII VIII - Option I - Option II

Basic Model No.

Measuring span	4.0 to 104 kPa abs (30 to 780 mmHg abs.) *13	STU940 *29	Flush diaphragm flange type: 3 inches (80 mm)
	35 to 3500 kPa abs (0.35 to 35 kgf/cm <sup>2</sup> abs.) *14		Extended diaphragm flange type: 4 inches (100 mm)

Selection I					Fill fluid code		
					Code	Flush diaphragm flange type	Extended diaphragm flange type
I	Fill fluid	Flange type	Model No.	Fill fluid		3 inches (80 mm)	4 inches (100 mm)
		Flush diaphragm flange type	3 inches (80 mm)	For high-temperature high-vacuum service (Silicone oil)	7		
		Extended diaphragm flange type	4 inches (100 mm)				
II	Flange standard	ANSI flange			A	✓	✓
		JIS flange			J	✓	✓
		JPI flange			P	✓	✓
III	Flange type & rating	Flush diaphragm flange type	80 mm - 10K 3 inches - 150		A	✓	
			80 mm - 30K 3 inches - 300		B	✓	
		Extended diaphragm flange type	100 mm - 10K 4 inches - 150		C		✓
			100 mm - 30K 4 inches - 300 *20		D		✓
IV	Flange material	SUS304			7	✓	✓
		SUS316			2	✓	✓
		SUS316L *3			8	✓	✓
V	Material of wetted parts	SUS316 (Diaphragm: SUS316L, others: SUS316)			2		✓
		SUS316L (Diaphragm: SUS316L, others: SUS316L)			8	✓	✓
		Tantalum (Diaphragm: Tantalum, others: Tantalum) *17			4	✓	
		Hastelloy C (Diaphragm: Hastelloy C, others: Hastelloy C)			9	✓	
VI	Finish of gasket face	Standard (JIS Ra3.2 (12.5S))			J	✓	✓
VII	Length of extended parts	Flush diaphragm 3 inches (80 mm)			00	✓	
		L = 50 mm (4 inches / 100 mm)			05		✓
		L = 100 mm (4 inches / 100 mm)			10		✓
		L = 150 mm (4 inches / 100 mm)			15		✓
VIII	Length of capillary tube	2 m			2	✓	✓
		3 m			3	✓	✓
		4 m			4	✓	✓
		5 m			5	✓	✓

(Continued)

Note) \*13 Specify range in abs. pressure. Correct: 0 to 500 mmHg abs. Incorrect: -700 mmHg to 1 kgf/cm<sup>2</sup>

\*14 Specify range in abs. pressure. Correct: 0 to 3 kgf/cm<sup>2</sup> abs. Incorrect: -1 to 2 kgf/cm<sup>2</sup> abs.

\*17 In case "Tantalum" is used for diaphragm material and in case of "for high-temperature high-vacuum service", normal operating conditions of meter body (process fluid) temperature is -10 to +180°C

\*20 In case "JIS30K" is used for flange type & rating and in case "SUS316L" is used for flange material, the extended diaphragm flange type is not available.

\*29 Notes of "Order entry"

SH No.	SH8989	Must be specified in "Remarks of order entry sheets"
Code No.	R5 or R6	Must be specified in "Options II"
	Measuring Span	R5 4.0 to 104 kPa abs. (30 to 780 mmHg abs.) *5
		R6 35 to 3500 kPa abs. (0.35 to 35 kgf/cm <sup>2</sup> abs.) *6
Code No.	U	Must be selected in "Options I"

(Continued from previous page)

Model No.: STU940 - I II III IV V VI VII VIII - Option I - Option II

		Code	Fill Fluid Code	
			Flush diaphragm flange type	Extended diaphragm flange type
			3 inches (80 mm)	4 inches (100 mm)
		-		
Option I	Lightning arrester	L	✓	✓
	Built-in indicating smart meter (0 to 100% liner scales)	P	✓	✓
	Built-in indicating smart meter (engineering unit scales)	R	✓	✓
	SUS630 bolt and nuts material *29	U	✓	✓
	Corrosion-resistant finish	A	✓	✓
	Corrosion-proof finish	B	✓	✓
	Corrosion-resistant finish, silver coating	D	✓	✓
	Oil free finish	K	✓	✓
	FM Explosionproof	3	✓	✓
	FM Intrinsically safe	4	✓	✓
	Combination of FM Explosionproof and Intrinsically safe	5	✓	✓
	ATEX Flameproof	6	✓	✓
	ATEX Intrinsic safety	7	✓	✓
	CSA Explosion proof	8	✓	✓
		-		
Options II	No option	XX		
	Burn-out feature (Lower limit of value at abnormal condition) *2	A4	✓	✓
	Burn-out feature (Upper limit of value at abnormal condition) *2	A5	✓	✓
	Water free finish (with Oil free finish)	A7	✓	✓
	NEPSI Flameproof	C1	✓	✓
	NEPSI Intrinsically safe	C2	✓	✓
	Custom calibration	C7	✓	✓
	Digital output *38	D5	✓	✓
	HART communication *5 *38	D7	✓	✓
	One elbow	E1	✓	✓
	Two elbows	E2	✓	✓
	External zero/span adjustment	E5	✓	✓
	Mounting bracket	E9	✓	✓
	Material certificate	H2	✓	✓
	Absolute Pressure Type: 4.0 to 104 kPa abs (30 to 780 mmHg abs.) *29	R5	✓	✓
	Absolute Pressure Type: 35 to 3500 kPa abs (0.35 to 35 kgf/cm <sup>2</sup> abs.) *29	R6	✓	✓
	SI unit	U1	✓	✓

Note) \*2 The output current value ranges from 3.0 to 3.8 mA for the lower limit and from 20.8 to 21.8 mA for the upper limit.

\*3 In case "for oxygen or chlorine (fluorine oil) service" is used, "oil free finish - code K" must be selected.

\*5 Intrinsically safe for NEPSI cannot be selected with -D7.

\*13 Specify range in abs. pressure. Correct: 0 to 500 mmHg abs. Incorrect: -700 mmHg to 1 kgf/cm<sup>2</sup>

\*14 Specify range in abs. pressure. Correct: 0 to 3 kgf/cm<sup>2</sup> abs. Incorrect: -1 to 2 kgf/cm<sup>2</sup> abs.

\*17 In case "Tantalum" is used for diaphragm material and in case of "for high-temperature high-vacuum service", normal operating conditions of meter body (process fluid) temperature is -10 to +180°C.

\*20 In case flange rating: JIS30K, wetted parts material: SUS316L and for high-temperature service, extended diaphragm type is not available.

\*29 Notes of "Order entry"

SH No.	SH8989	Must be specified in "Remarks of order entry sheets"
Code No.	R5 or R6	Must be specified in "Options II"
	Measuring span	R5 4.0 to 104 kPa abs. (30 to 780 mmHg abs.) *5
		R6 35 to 3500 kPa abs. (0.35 to 35 kgf/cm <sup>2</sup> abs.) *6
Code No.	U	Must be selected in "Options I"

\*38 Either one of "digital output - code D5" or "HART communication - code D7" can be selected at a time.

**DIMENSIONS**

**Model STU940 High-temperature vacuum and high-temperature high-vacuum service**

2 inches wafer

[Unit: mm]

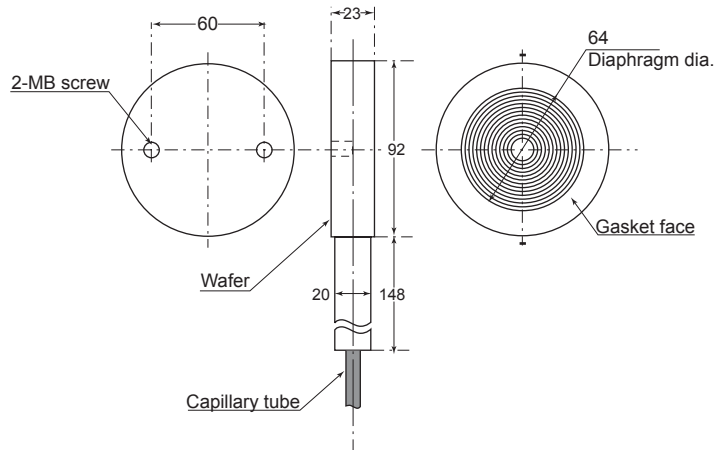

**Flush diaphragm flange / Extended diaphragm flange**

[Unit: mm]

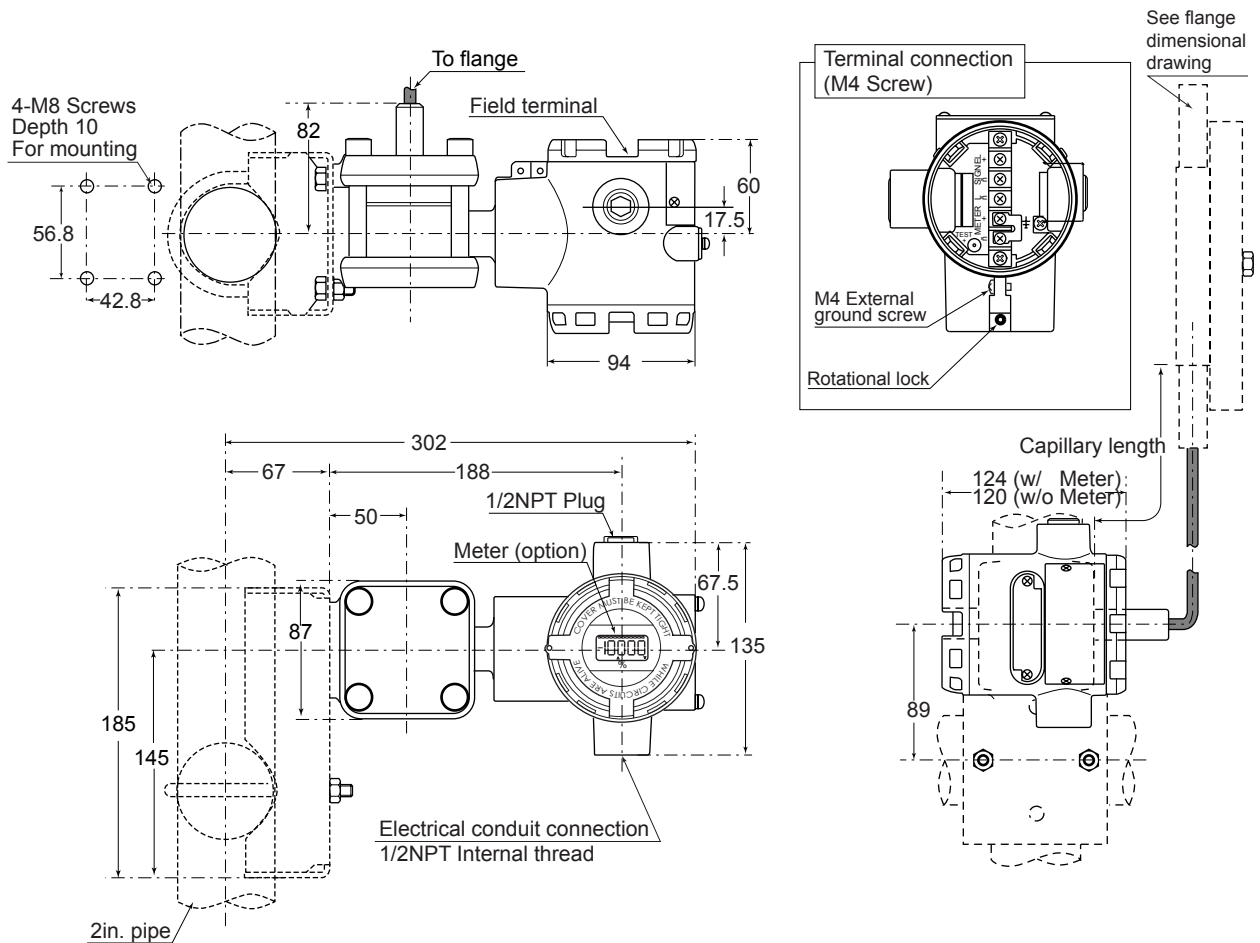

**Model STU960 High-temperature vacuum and high-temperature high-vacuum service**

**Flush diaphragm flange / Extended diaphragm flange**

[Unit: mm]

See flange dimensional drawing

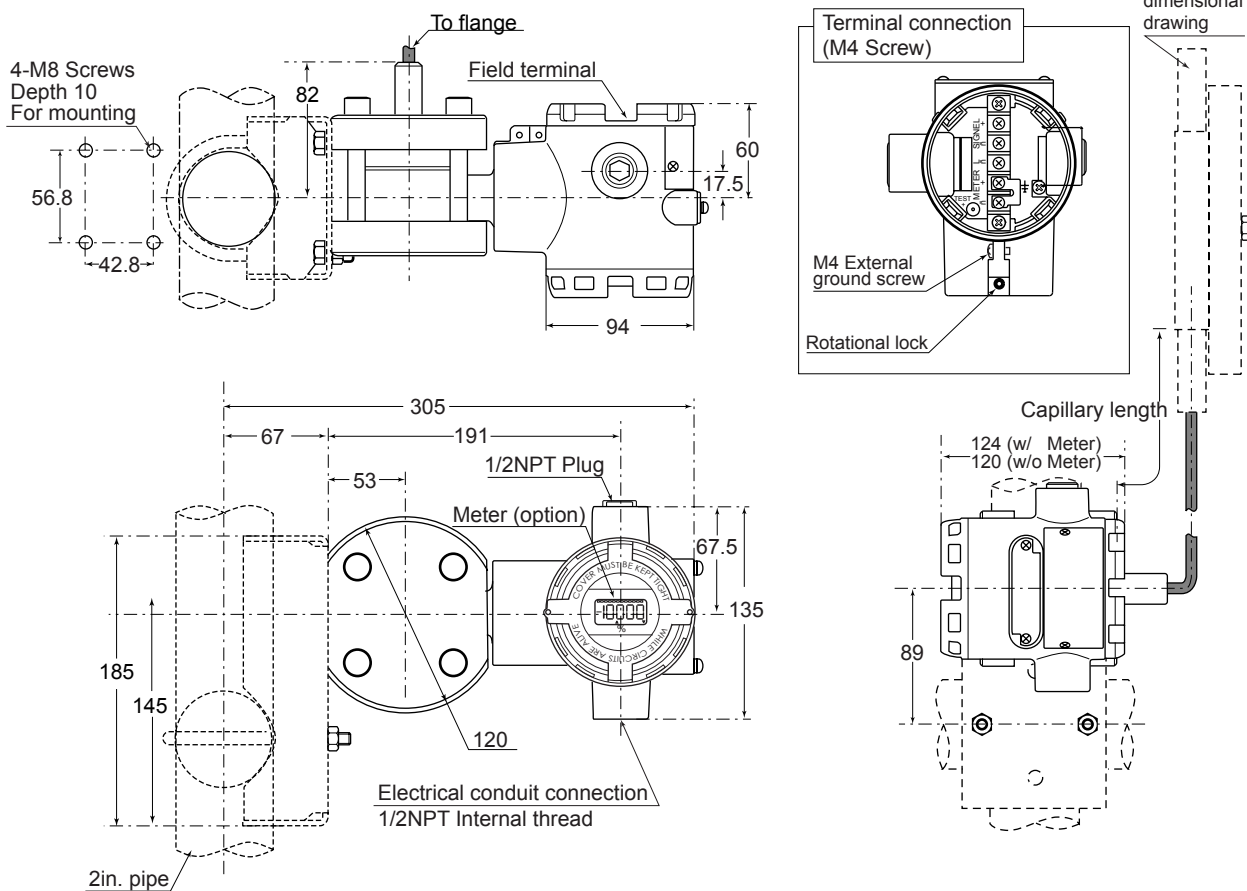

**Model STU980 (for regular type and high-temperature service)**

**Bottom diaphragm**

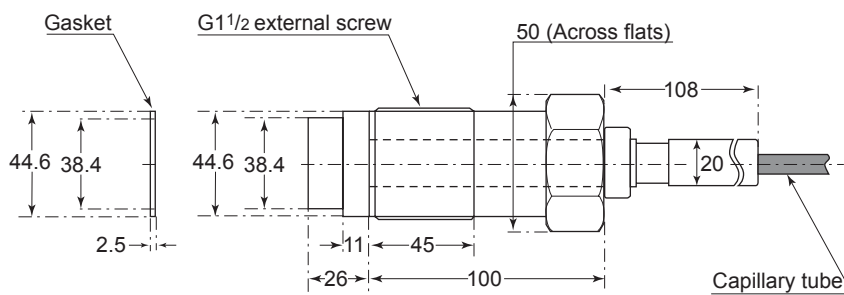

2-inch wafer

[Unit: mm]

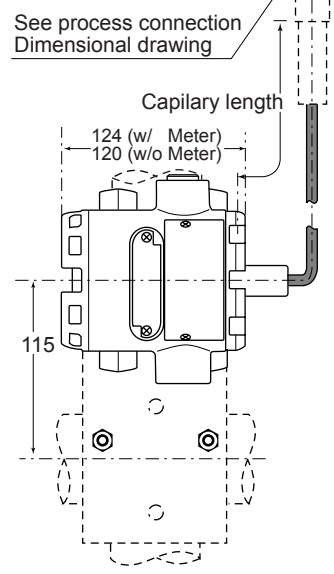
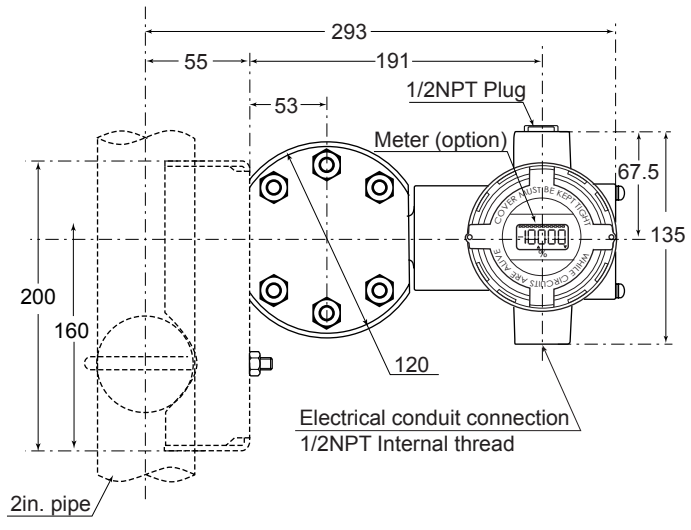
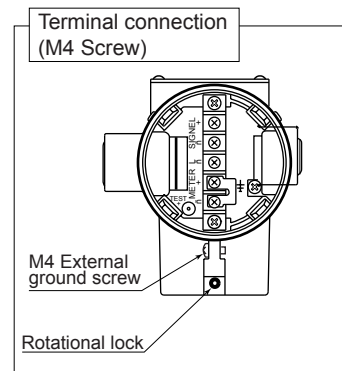
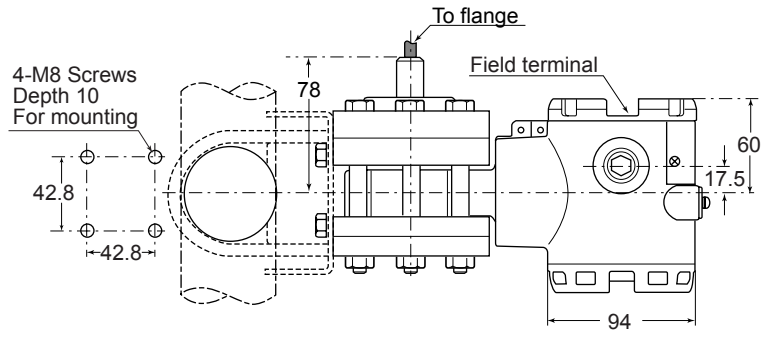

Process connection

Table of flange dimension  
Flush diaphragm flange

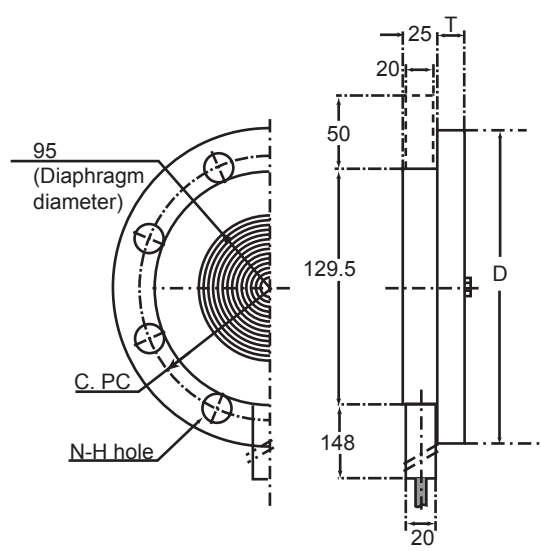

Rating	Flange rating	D	T	C	N	H
3 inches / 80 mm	JIS 10K - 80 mm	185	18	150	8	19
	JIS 20K - 80 mm	200	22	160	8	23
	JIS 30K - 80 mm	210	28	170	8	23
	ANSI 150 - 3 inches	190	24	152	4	19
	ANSI 300 - 3 inches	210	28.5	168	8	22
	JPI 150 - 3 inches	190	24	152	4	19
	JPI 300 - 3 inches	210	28.5	168	8	22

Extended diaphragm flange

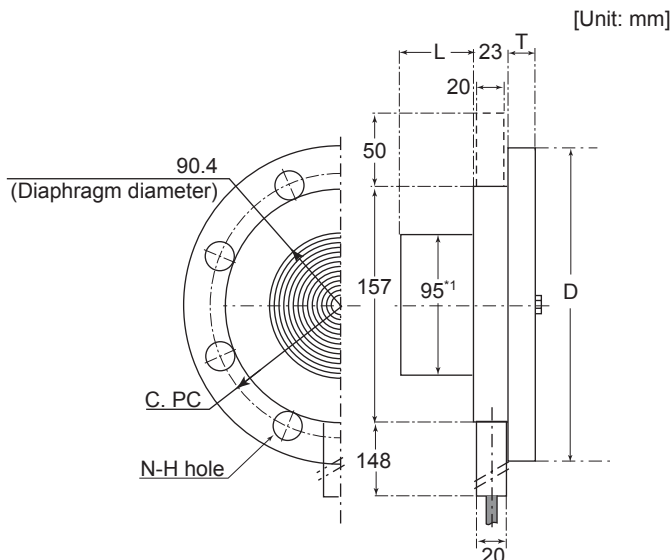

Rating	Flange rating	D	T	C	N	H
4 inches / 100 mm	JIS 10K - 100 mm	210	18	175	8	19
	JIS 20K - 100 mm	225	24	185	8	23
	JIS 30K - 100 mm	240	32	195	8	25
	ANSI 150 - 4 inches	229	24	191	8	19
	ANSI 300 - 4 inches	254	32	200	8	22
	JPI 150 - 4 inches	229	24	191	8	19
	JPI 300 - 4 inches	254	32	200	8	22

Extended length L
50
100
150
200
250
300

Yamatake Corporation

Totate international Building  
 2-12-19 Shibuya  
 Shibuya-ku, Tokyo 150-8316  
 Japan  
 Tel : 81-3-3486-2310  
 Fax : 81-3-3486-2593



Certificate No. Q17862



Certificate No. E8318  
 For Shonan Factory



Savemation

Saving through Automation