

ST3000 Series 900 Smart Transmitter

Remote-sealed type of Pressure Transmitters with FOUNDATION™ fieldbus

Model STH920 / STH940 / STH960 / STH980

OVERVIEW

The ST3000 Series 900 with FOUNDATION™ fieldbus is an accurate, stable, and reliable pressure / differential pressure transmitter, which fully complies with the 31.25 kbps voltage mode FOUNDATION™ fieldbus. Its built-in AI function blocks provide process variables to devices on the Fieldbus and its PID control function block enables process control in the field.

Since the ST3000 Series 900 is FOUNDATION™ registered, it can operate seamlessly with other registered field devices as well as host systems in a wide range of control applications.

FEATURES

Excellent stability and high performance

- Long-term stability is proven in 500,000 installations worldwide.
- Unique characterization and composite semiconductor sensors realize excellent temperature and static pressure characteristics.

A diverse lineup

- A diverse flange lineup, ranging from small diameter 1.5 in. (40 mm) and 2 in. (50 mm) to 3 in. (80 mm), is available to meet user requirements.
- A wide range of models, including those for general purposes, high-temperature, and high-temperature and high-vacuum service, is available to meet user requirements. In addition, the working temperature range of general purpose models has been expanded to 180°C maximum to allow you greater freedom instrumentation.
- A wide variety of corrosion-resistant materials for wetted parts is also available.

Function to correct the temperature of the fill fluid of the capillary section

Changes in the density of the fill fluid caused by temperature fluctuations are calculated, and the output is corrected accordingly. This function substantially reduces (to 1/5-1/10) the effect of seasonal fluctuations in temperature.

FOUNDATION™ is a registered trademark of the Fieldbus Foundation.

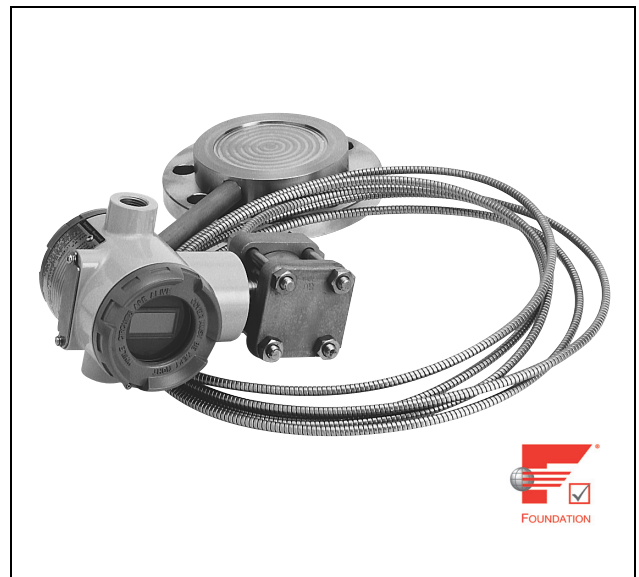

APPLICATION

Petroleum / Petrochemical / Chemical

- For the measurement of liquid levels including corrosive fluids at high temperatures, and high temperatures under vacuum
- For the measurement of liquid levels in small tanks

Electric power / City gas / Other utilities

For measurement applications that require high degrees of stability and accuracy.

Pulp and paper

- For lines that need transmitters resistant to chemical liquids, corrosive fluids and the like.
- For the measurement of liquid levels in small tanks

Iron and steel / Nonferrous metal / Ceramics

For lines that require stable measurement under strictly controlled (temperature, humidity, etc.) conditions.

Machinery / Shipbuilding

For lines that require stable measurement under strictly controlled (temperature, humidity, etc.) conditions.

FUNCTIONAL SPECIFICATIONS

Type of protection

JIS C0920 watertight: NEMA3 and 4X
 JIS F8001 class 2 watertight: IEC IP67

FM Explosionproof approval

Explosionproof for Class I (Gas, steam), Division 1, Group A, B, C, D

Dust-ignition for Class II (Inflammable dust), Division 1, Group E, F, G

Suitable for Class III (inflammable fiber), Division 1

Nonincendive for Class I, Division 2, Group A, B, C, D

ATEX Flameproof approval

Ⓔ II 2 GD EEx d IIC T6 at $-20 \leq T_{amb} \leq +60^{\circ}\text{C}$

NEPSI Flameproof approval

Ex d IIC T6 (with NEPSI Dust Ignition DIP DT T13)

EMC Conformity

89/336/EEC, 92/31/EEC, 93/68/EEC Electromagnetic Compatibility (EMC) Directive

PED Conformity (97/23/EC)

Comply with Module H (with “H1” option), or SEP (Sound Engineering Practice) for models of which maximum working pressure is 200 bar or lower.

Lowest temperature for Module H

Bolt/nut material SNB7: -10°C
 SUS630: -6°C

Measuring span / Setting range / Working pressure range

	Measuring Span	Setting Range	Working Pressure Range	Overload Resistant Value
STH 920	2.5 to 100 kPa {250 to 10160 mmH ₂ O}	-100 to 100k Pa {-10160 to 10160 mmH ₂ O}	Up to flange rating (For negative pressures, see Figure 1, 2 and .)	None
STH 940	35 to 3500kPa {0.35 to 35 kgf/cm ² }	-100 to 3500 kPa {-1 to 35 kgf/cm ² }	Up to flange rating (For negative pressures, see Figure 1, 2 and .)	5250 kPa {52.5 kgf/cm ² }
STH 960	0.7 to 10 MPa {7 to 102 kgf/cm ² }	-0.1 to 10 MPa {-1 to 102 kgf/cm ² }	Up to flange rating (For negative pressures, see Figure 1, 2 and .)	15.3 MPa {153 kgf/cm ² }
STH 980	0.7 to 42 MPa {7 to 420 kgf/cm ² }	-0.1 to 42 MPa {-1 to 420 kgf/cm ² }	Up to flange rating (For negative pressures, see Figure 1, 2 and .)	63 MPa {630 kgf/cm ² }

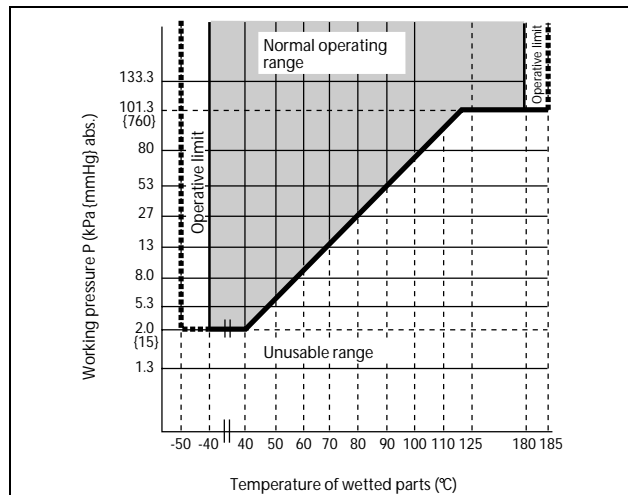

Figure 1 Working pressure and temperature of wetted parts section (for general purpose models)

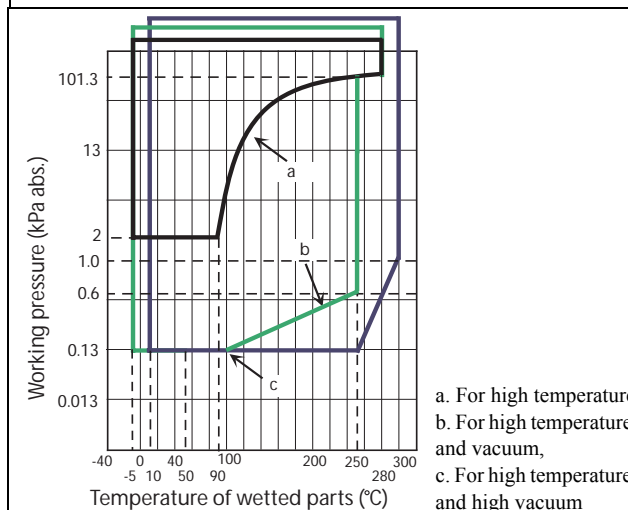

Figure 2 Working pressure temperature of wetted parts section (For high temperature / high temperature and vacuum / high temperature and high vacuum)

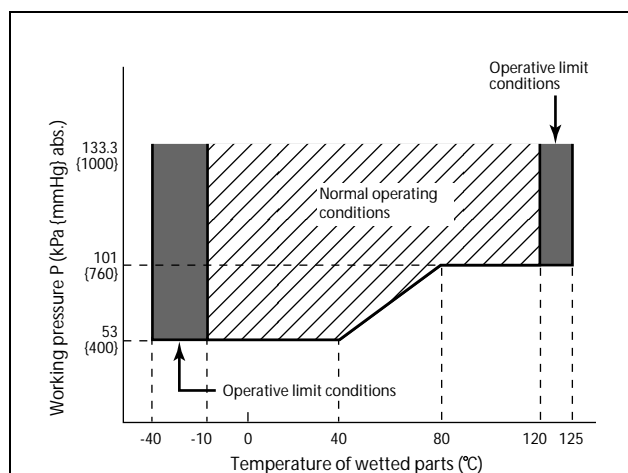

Figure 3 Working pressure and temperature of wetted parts section (for oxygen and chlorine models)

Supply voltage

9 to 32 V DC

Ambient temperature limits / Temperature ranges of wetted parts

		Temperature range (°C) Note 1), 4)				
		General purpose model	High-temperature model	High-temperature Vacuum models	High-temperature High-vacuum models	Oxygen and Chlorine models
Wetted parts section	Normal operating range	-40 to 180	-5 to 280 Note 5)	-5 to 280 Note 5)	10 to 280 Note 5)	-10 to 120
	Operative limit range	-50 to 185	-10 to 310 Note 6)	-10 to 310 Note 6)	-10 to 310 Note 6)	-40 to 125
Ambient temperature Note 2) Flange diameter: Flush diaphragm type 3 in.(80mm) Extended diaphragm type 4 in.(100mm)	Normal operating range	-30 to 75	-5 to 55	-5 to 55	10 to 55	-10 to 75
	Operative limit range	-50 to 80	-10 to 60	-10 to 60	-10 to 60	-40~80
Ambient temperature Note 2) Flange diameter: Flush diaphragm type 2 in.(50mm)/1.5 in.(40mm) Extended diaphragm type 3 in.(80mm)/2 in.(50mm)	Normal operating range	-15 to 65	-5 to 45	-5 to 55	10 to 55	-10 to 75
	Operative limit range	-30 to 80	-10 to 55	-10 to 60	-10 to 60	-40 to 80
Specific gravity of fill fluid Note 3)		0.935	1.07	1.07	1.09	1.87

- Note) 1. See the working pressures and temperatures of the wetted parts section in Figure 1, Figure 2, and Figure 3.
 2. Ambient temperatures of the transmitter itself
 3. Approximate values at the temperature of 25°C
 4. Note that if the operating temperature falls below the lower limit of the normal operating range, the response of the transmitter becomes slower.
 5. When the wetted parts material is tantalum, the upper limit is 180°C.
 6. When the wetted parts material is tantalum, the upper limit is 200°C.

For explosionproof models with digital indicators, which have to be used within the following ranges

Normal operating condition

-20 to 70°C

Operative limit

-30 to 80°C

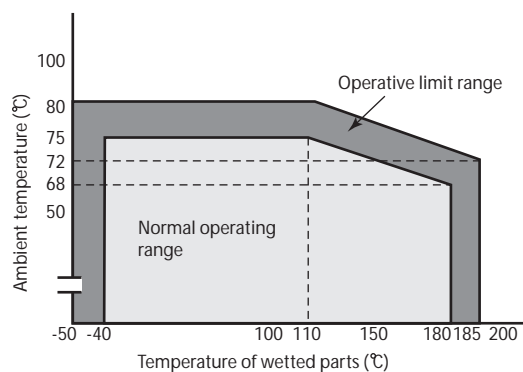

Figure 4 Ambient temperature and temperature of wetted parts section (for general purpose models)

[Flange diameter: Flush diaphragm 2 in. (50 mm) / 1.5 in. (40 mm)
 Extended diaphragm 3 in. (80 mm) / 2 in. (50 mm)]

Note) When the fill liquid is for general purposes, make sure before using your transmitter that the conditions in both Figure 1, Figure 4 and Figure 5 are met.

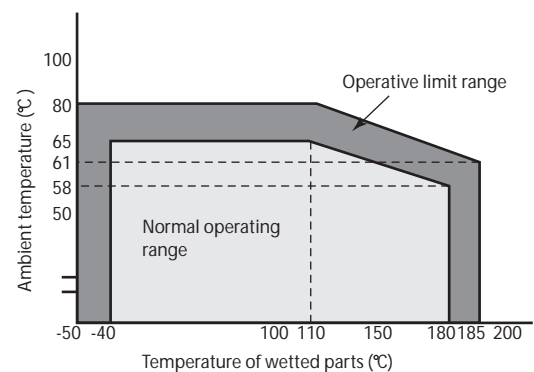

Figure 5 Ambient temperature and temperature of wetted parts section (for general purpose models)

[Flange diameter: Flush diaphragm 3 in. (80 mm)
 Extended diaphragm 4 in. (100 mm)]

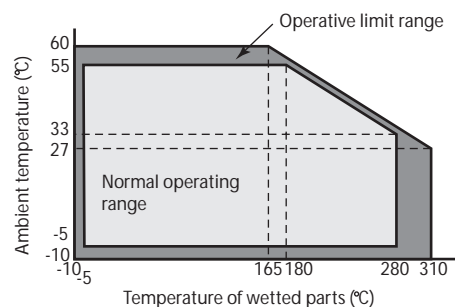

Figure 6 Ambient temperature and temperature of wetted parts section (for high temperature and vacuum 2, 3m)

[Flange diameter: Flush diaphragm 2 in. (50 mm) / 1.5 in. (40mm)]

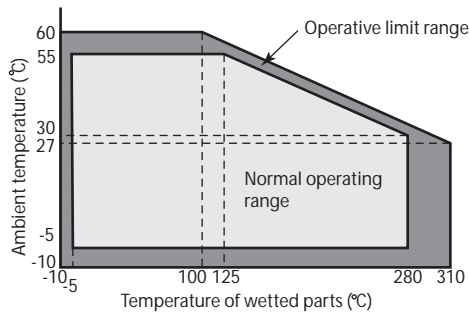

Figure 7 Ambient temperature and temperature of wetted parts section (for high temperature and vacuum 4, 5 m)

[Flange diameter: Flush diaphragm 2 in. (50 mm) / 1.5 in. (40 mm)]

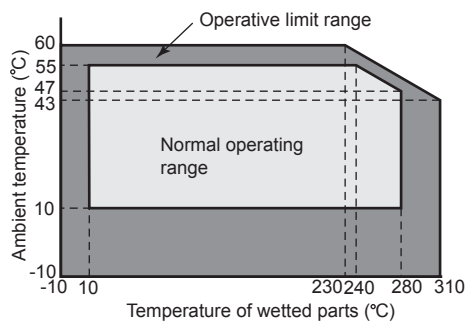

Figure 8 Ambient temperature and temperature of wetted parts section (for high temperature and high vacuum 2, 3 m)

[Flange diameter: Flush diaphragm 2 in. (50 mm) / 1.5 in. (40 mm)]

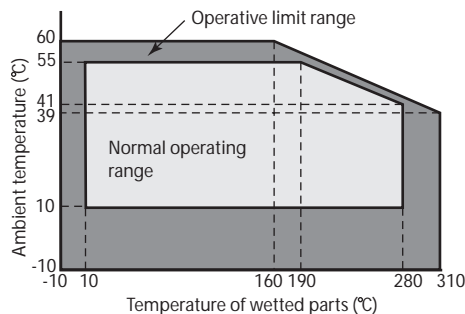

Figure 9 Ambient temperature and temperature of wetted parts section (for high temperature and high vacuum 4, 5 m)

[Flange diameter: Flush diaphragm 2 in. (50 mm) / 1.5 in. (40 mm)]

Ambient humidity limits

5 to 100% RH

Stability against supply voltage change

± 0.005% FS/V

Lightning protection

Peak value of voltage surge: 12 kV

Peak value of current surge: 1000 A

Optional specifications

Built-in indicating meter

The digital LCD indicator (optional) indicates engineering units and can be set freely between -19999 and 19999 (4.5 digits).

Bolts and nuts materials (for fastening meter body cover)

Carbon steel (SNB7), SUS304, SUS630

(Pressure rating 7000 kPa {70 kgf/cm²} or Flange rating)

Baked acrylic paint.

Corrosion-resistant finish

Corrosion-resistant finish

Corrosion-resistant paint (Baked acrylic paint), fungus-proof finish.

Corrosion-proof finish

Corrosion-proof paint (Baked epoxy paint), fungus-proof finish.

Corrosion-resistant finish (silver paint)

Transmitter case is coated with silver paint in addition to the above corrosion-resistant finish.

FEP protective film

Use FEP protective film when corrosive fluids are used or to avoid metal ions contact.

Working temperature range

0 to 110°C

Working pressure range

Atmospheric pressure to flange rating

(up to JIS10K, ANSI/JPI 150)

(Not usable under negative pressure)

Oil free finish

The transmitter is shipped with oil-free wetted parts.

(The vent drain plug is coated with a small amount of fluorine oil to prevent galling.)

Elbow

This is an adaptor for changing the electrical conduit connection port from the horizontal to the vertical direction, if required by wiring conditions in the field. One or two elbows may be used as needed.

Conformance to SI units

We deliver transmitters set to any SI units as specified.

PHYSICAL SPECIFICATIONS**Materials****Fill fluid**

Silicone oil for general purpose and high-temperature vacuum models

Fluorine oil for oxygen and chlorine models

For specific gravity, refer to .

Center body

SUS316

Transmitter case

Aluminum alloy

Meter body cover

SUSF304

For wetted parts

SUS316 (SUS316L for diaphragm only)

Hastelloy C, Tantalum, SUS316L

Flange materials

SUS304, SUS316, SUS316L

Capillary section**Capillary tube length**

2, 3, 4, 5, 6, 7, 8, 9 and 10 m

2, 3, 4 and 5 m when flange diameter is flush diaphragm

2 in. (50 mm) / 1.5 in. (40 mm) extended diaphragm

3 in. (80 mm) / 2 in. (50 mm) (same for olefin covering)

Capillary tube material

SUS316

Armored tube material

SUS304

Coating (optional)

Olefin coating to improve corrosion resistance

Finish

Baked acrylic paint

Housing light beige (Munsell 4Y7.2/1.3)

Cap dark beige (Munsell 10YR4.7/0.5)

Weight

Approx. 19.8 kg

(Including JIS10K - 80 mm flange and capillary 5 m long)

INSTALLATION**Electrical connection**

1/2NPT internal thread

Grounding

Resistance 100 Ω max.

Mounting

Direct mounting on the process side

Using 2 inch pipe mounting brackets: Mount the transmitter on a horizontal or vertical 2 inch pipe.

Bracket

Carbon steel

U-bolt and nuts

SUS304

Process connection**Measured pressure (liquid side)**

Flanges (both higher and lower pressure sides)

Flush diaphragm

JIS10K, 20K and 30K: 40 mm / 50 mm / 80 mm (RF) equivalents

ANSI 150, 300 and 600: 1.5 in. / 2 in. / 3 in. (RF) equivalents

JPI 150, 300 and 600: 1.5 in./2 in./ 3 in. (RF) equivalents

Extended diaphragm

JIS 10K, 20K and 30K: 50 mm / 80 mm / 100 mm (RF) equivalents

JIS 10K, 20K and 30K: 100 mm / 80 mm / 50 mm (RF) equivalents

ANSI 150 and 300: 2 in. / 3 in. / 4 in. (RF) equivalents

ANSI 150 and 300: 4 in. / 3 in. / 2 in. (RF) equivalents

JPI 150 and 300: 2 in. / 3 in. / 4 in. (RF) equivalents

JPI 150 and 300: 4 in./ 3in./ 2 in. (RF) equivalents

Screw connection

G1/2 button diaphragm (G1½ external thread)

Mounting notes**For pressure measurement**

- 1) If the fluid to be measured contains hydrogen, please consult us.
- 2) When mounting the transmitter, leave a space of at least 10 cm under the upper nozzle of the tank. If no space is available, please consult us.

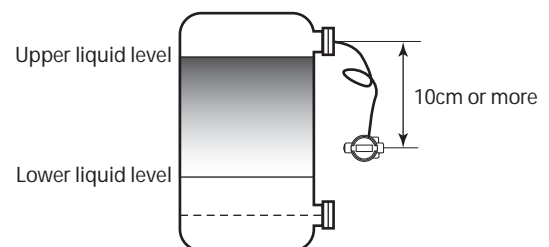

PERFORMANCE SPECIFICATIONS

Max working pressure

- Note) 1. Max working pressure depends on flange rating, flange materials and operating temperature. Please refer to the following data. Operating range of temperature depends on specification of transmitters.
- Note) 2. In case of flange type (model STC940□) and remote scaled type (model STU940□, model STH940□), max working pressure depends on the smaller value of either 1.5 MPa or following data.
- Note) 3. In case of remote sealed type (model STH960□), max working pressure depends on the smaller value of either 10 MPa or following data.

	JIS	JPI/ANSI
SUS304		
SUS316		
SUS316L		

Accuracy

Shown for each item is the percentage ratio for χ (kPa), which is the greatest value of either XD_SCALE_EU_100^(*1), XD_SCALE_EU_0^(*2), or the span.

Model STH920 (for regular type and high-temperature service)

Material of wetted parts: Diaphragm; SUS316L, Others; SUS316

Flange size: Flush diaphragm 3 in. (80 mm), Extended diaphragm 4 in. (100mm)

Accuracy (*3)		$\pm 0.3\%$	(For $\chi \geq 12.5kPa$ {1250 mmH ₂ O})
		$\pm\left(0.3 \times \frac{12.5}{\chi}\right) \%$	(For $\chi < 12.5kPa$ {1250 mmH ₂ O})
Temperature characteristics (Shift from the set range) Change of 55°C(*3)	Zero shift:	$\pm 1.25\%$	(For $\chi \geq 25kPa$ {2500 mmH ₂ O})
		$\pm\left(1.25 \times \frac{2.5}{\chi}\right) \%$	(For $\chi < 25kPa$ {2500 mmH ₂ O})
	Combined shift: (including zero and span shifts)	$\pm 2.5\%$	(For $\chi \geq 25kPa$ {2500 mmH ₂ O})
		$\pm\left(2.5 \times \frac{25}{\chi}\right) \%$	(For $\chi < 25kPa$ {2500 mmH ₂ O})

Model STH920 (for regular type and high-temperature service)

Material of wetted parts: Diaphragm; Hastelloy C, Tantalum, SUS316L Others; Hastelloy C, Tantalum, SUS316L

Flange size: Flush diaphragm 3 in. (80 mm)

Accuracy (*3)		$\pm 0.4\%$	(For $\chi \geq 12.5kPa$ {1250 mmH ₂ O})
		$\pm\left(0.4 \times \frac{12.5}{\chi}\right) \%$	(For $\chi < 12.5kPa$ {1250 mmH ₂ O})
Temperature characteristics (Shift from the set range) Change of 30°C(Range from the -5 to 55°C) (*3)	Zero shift:	$\pm 3.2\%$	(For $\chi \geq 25kPa$ {2500 mmH ₂ O})
		$\pm\left(3.5 \times \frac{25}{\chi}\right) \%$	(For $\chi < 25kPa$ {2500 mmH ₂ O})
	Combined shift:	$\pm 4.5\%$	(For $\chi \geq 25kPa$ {2500 mmH ₂ O})
		$\pm\left(4.5 \times \frac{25}{\chi}\right) \%$	(For $\chi < 25kPa$ {2500 mmH ₂ O})

Model STH940 (for regular type and high-temperature service)

Material of wetted parts: Diaphragm; SUS316L, Others; SUS316

Flange size: Flush diaphragm 3 in. (80 mm) Extended diaphragm 4 in. (100 mm)

Accuracy (*3)		$\pm 0.2\%$	(For $\chi \geq 350kPa$ {3.5 kgf/cm ² })
		$\pm\left(0.05 + 0.15 \times \frac{350}{\chi}\right) \%$	(For $\chi < 350kPa$ {3.5 kgf/cm ² })
Temperature characteristics (Shift from the set range) Change of 55°C(*3)	Zero shift:	$\pm\left(0.25 + 0.5 \times \frac{350}{\chi}\right) \%$	χ : kPa
	Combined shift:	$\pm 1.05\%$	(For $\chi \geq 350kPa$ {3.5 kgf/cm ² })
		$\pm\left(0.35 + 0.7 \times \frac{350}{\chi}\right) \%$	(For $\chi < 350kPa$ {3.5 kgf/cm ² })

Model STH940 (for regular type and high-temperature service)

Material of wetted parts: Diaphragm; Hastelloy C, Tantalum, SUS316L Others; Hastelloy C, Tantalum, SUS316L

Flange size: Flush diaphragm 3 in. (80 mm)

Accuracy(*3)		$\pm 0.2\%$	(For $\chi \geq 350kPa$ {3.5 kgf/cm ² })
		$\pm\left(0.05 + 0.15 \times \frac{350}{\chi}\right) \%$	(For $\chi < 350kPa$ {3.5 kgf/cm ² })
Temperature characteristics (Shift from the set range) Change of 30°C (Range from -5 to 55°C) (*3)	Zero shift:	$\pm\left(0.15 + 0.5 \times \frac{350}{\chi}\right) \%$	χ : kPa
	Combined shift:	$\pm 0.9\%$	(For $\chi \geq 350kPa$ {3.5 kgf/cm ² })
		$\pm\left(0.35 + 0.55 \times \frac{350}{\chi}\right) \%$	(For $\chi < 350kPa$ {3.5 kgf/cm ² })

Note) (*1): XD_SCALE_EU_100 denotes the upper limit of the calibration range.

(*2): XD_SCALE_EU_0 denotes the lower limit of the calibration range.

(*3): Within a range of XD_SCALE_EU_100 ≥ 0 and XD_SCALE_EU_0 ≥ 0 .

Model STH960 (for regular type and high-temperature service)

Material of wetted parts: Diaphragm; SUS316L, Others; SUS316
 Flange size: Flush diaphragm 3 in. (80 mm), Extended diaphragm 4 in. (100 mm)

Accuracy(*3)		$\pm 0.2\%$	(For $\chi \geq 3.5MPa$ {35 kgf/cm ² })
		$\pm\left(0.05 + 0.15 \times \frac{3.5}{\chi}\right) \%$	(For $\chi < 3.5MPa$ {35 kgf/cm ² })
Temperature characteristics (Shift from the set range) Change of 55°C(*3)	Zero shift:	$\pm\left(0.25 + 0.5 \times \frac{3.5}{\chi}\right) \%$	χ : kPa
	Combined shift:	$\pm 1.05\%$	(For $\chi \geq 3.5MPa$ {35 kgf/cm ² })
		$\pm\left(0.35 + 0.7 \times \frac{3.5}{\chi}\right) \%$	(For $\chi < 3.5MPa$ {35 kgf/cm ² })

Model STH960 (for regular type and high-temperature service)

Material of wetted parts: Diaphragm; Hastelloy C, Tantalum, SUS316L Others; Hastelloy C, Tantalum, SUS316L
 Flange size: Flush diaphragm 3 in. (80 mm)

Accuracy(*3)		$\pm 0.2\%$	(For $\chi \geq 3.5MPa$ {35 kgf/cm ² })
		$\pm\left(0.05 + 0.15 \times \frac{3.5}{\chi}\right) \%$	(For $\chi < 3.5MPa$ {35 kgf/cm ² })
Temperature characteristics (Shift from the set range) Change of 30°C(*3) (Range from -5 to 55°C)	Zero shift:	$\pm\left(0.15 + 0.5 \times \frac{3.5}{\chi}\right) \%$	χ : kPa
	Combined shift:	$\pm 0.9\%$	(For $\chi \geq 3.5MPa$ {35 kgf/cm ² })
		$\pm\left(0.35 + 0.55 \times \frac{3.5}{\chi}\right) \%$	(For $\chi < 3.5MPa$ {35 kgf/cm ² })

Model STH940 (for regular type and high-temperature service)

Material of wetted parts: Diaphragm; SUS316L, Others; SUS316
 Flange size: Flush diaphragm 2 in. (50 mm) / 1.5 in. (40 mm), Extended diaphragm 3 in. (80 mm) / 2 in.(50 mm)

Accuracy(*3)		$\pm 0.2\%$	(For $\chi \geq 350kPa$ {3.5 kgf/cm ² })
		$\pm\left(0.2 \times \frac{350}{\chi}\right) \%$	(For $\chi < 350kPa$ {3.5 kgf/cm ² })
Temperature characteristics (Shift from the set range) Change of 55°C(*3)	Zero shift:	$\pm\left(0.25 + 0.5 \times \frac{350}{\chi}\right) \%$	χ : kPa
	Combined shift:	$\pm 1.05\%$	(For $\chi \geq 350kPa$ {3.5 kgf/cm ² })
		$\pm\left(0.35 + 0.7 \times \frac{350}{\chi}\right) \%$	(For $\chi < 350kPa$ {3.5 kgf/cm ² })

Model STH940 (for regular type and high-temperature service)

Material of wetted parts: Diaphragm; Hastelloy C, Tantalum, SUS316L Others; Hastelloy C, Tantalum, SUS316L
 Flange size: Flush diaphragm 2 in. (50 mm) / 1.5 in. (40 mm)

Accuracy (*3)	Analog mode:	$\pm 0.3\%$	(For $\chi \geq 350kPa$ {3.5 kgf/cm ² })
		$\pm\left(0.3 \times \frac{350}{\chi}\right)$	(For $\chi < 350kPa$ {3.5 kgf/cm ² })
Temperature characteristics (Shift from the set range) Change of 30°C(*3) (Range from -5 to 55°C)	Zero shift:	$\pm\left(0.68 \times \frac{350}{\chi}\right) \%$	(For $\chi \geq 350kPa$ {3.5 kgf/cm ² }) (For $\chi < 350kPa$ {3.5 kgf/cm ² })
	Combined shift:	$\pm 1.75\%$	(For $\chi \geq 350kPa$ {3.5 kgf/cm ² })
		$\pm\left(1.75 \times \frac{350}{\chi}\right) \%$	(For $\chi < 350kPa$ {3.5 kgf/cm ² })

Model STH960 (for regular type and high-temperature service)

Material of wetted parts: Diaphragm; SUS316L, Others; SUS316
 Flange size: Flush diaphragm 2 in. (50 mm) / 1.5 in. (40 mm), Extended diaphragm 3 in. (80 mm) / 2 in.(50 mm)

Accuracy (*3)		$\pm 0.2\%$	(For $\chi \geq 3.5MPa$ {35 kgf/cm ² })
		$\pm\left(0.2 \times \frac{3.5}{\chi}\right)$	(For $\chi < 3.5MPa$ {35 kgf/cm ² })
Temperature characteristics (Shift from the set range) Change of 55°C (*3)	Zero shift:	$\pm\left(0.25 + 0.5 \times \frac{3.5}{\chi}\right) \%$	χ : kPa
	Combined shift:	$\pm 1.5\%$	(For $\chi \geq 3.5MPa$ {35 kgf/cm ² })
		$\pm\left(0.35 + 0.7 \times \frac{3.5}{\chi}\right) \%$	(For $\chi < 3.5MPa$ {35 kgf/cm ² })

Note) (*3): Within a range of $XD_SCALE_EU_100 \geq 0$ and $XD_SCALE_EU_0 \geq 0$.

Model STH960 (for regular type and high-temperature service)

Material of wetted parts: Diaphragm; Hastelloy C, Tantalum, SUS316L Others; Hastelloy C, Tantalum, SUS316L

Flange size: Flush diaphragm 2 in. (50 mm) / 1.5 in. (40 mm)

Accuracy (*3)		$\pm 0.2\%$	(For $\chi \geq 3.5MPa$ {35 kgf/cm ² })
		$\pm\left(0.2 \times \frac{3.5}{\chi}\right)$	(For $\chi < 3.5MPa$ {35 kgf/cm ² })
Temperature characteristics (Shift from the set range) Change of 30°C(*3) (Range from -5 to 55°C)	Zero shift:	$\pm 0.68\%$	(For $\chi \geq 3.5MPa$ {35 kgf/cm ² })
		$\pm\left(0.68 \times \frac{3.5}{\chi}\right) \%$	(For $\chi < 3.5MPa$ {35 kgf/cm ² })
	Combined shift:	$\pm 1.75\%$	(For $\chi \geq 3.5MPa$ {35 kgf/cm ² })
		$\pm\left(1.75 \times \frac{3.5}{\chi}\right) \%$	(For $\chi < 3.5MPa$ {35 kgf/cm ² })

Model STH940 (for high temperature and vacuum / high temperature and high vacuum)

Material of wetted parts: Diaphragm; SUS316L, Others; SUS316

Flange size: Flush diaphragm 3 in. (80 mm), Extended diaphragm 4 in. (100 mm)

Accuracy (*3)		$\pm 0.2\%$	(For $\chi \geq 350kPa$ {3.5 kgf/cm ² })
		$\pm\left(0.05 + 0.15 \times \frac{350}{\chi}\right) \%$	(For $\chi < 350kPa$ {3.5 kgf/cm ² })
Temperature characteristics (Shift from the set range) Change of 30°C (Range from -5 to 55°C) (*3)	Zero shift:	$\pm\left(0.15 + 0.45 \times \frac{350}{\chi}\right) \%$	χ : kPa
	Combined shift:	$\pm 0.9\%$	(For $\chi \geq 350kPa$ {3.5 kgf/cm ² })
		$\pm\left(0.35 + 0.55 \times \frac{350}{\chi}\right) \%$	(For $\chi < 350kPa$ {3.5 kgf/cm ² })

Model STH940 (for high temperature and vacuum / high temperature and high vacuum)

Material of wetted parts: Hastelloy C, Tantalum

Flange size: Flush diaphragm 3 in. (80 mm), Extended diaphragm 4 in. (100 mm)

Accuracy (*3)		$\pm 0.2\%$	(For $\chi \geq 350kPa$ {3.5 kgf/cm ² })
		$\pm\left(0.05 + 0.15 \times \frac{350}{\chi}\right) \%$	(For $\chi < 350kPa$ {3.5 kgf/cm ² })
Temperature characteristics (Shift from the set range) Change of 30°C (Range from -5 to 55°C) (*3)	Zero shift:	$\pm\left(0.15 + 0.5 \times \frac{350}{\chi}\right) \%$	χ : kPa
	Combined shift:	$\pm 0.9\%$	(For $\chi \geq 350kPa$ {3.5 kgf/cm ² })
		$\pm\left(0.35 + 0.55 \times \frac{350}{\chi}\right) \%$	(For $\chi < 350kPa$ {3.5 kgf/cm ² })

Model STH960 (for high temperature and vacuum / high temperature and high vacuum)

Material of wetted parts: Diaphragm; SUS316L, Others; SUS316,

Flange size: Flush diaphragm 3 in. (80 mm), Extended diaphragm 4 in. (100 mm)

Accuracy (*3)		$\pm 0.2\%$	(For $\chi \geq 3.5MPa$ {35 kgf/cm ² })
		$\pm\left(0.05 + 0.15 \times \frac{3.5}{\chi}\right) \%$	(For $\chi < 3.5MPa$ {35 kgf/cm ² })
Temperature characteristics (Shift from the set range) Change of 30°C (*3) (Range from -5 to 55°C)	Zero shift:	$\pm\left(0.15 + 0.45 \times \frac{3.5}{\chi}\right) \%$	χ : MPa
	Combined shift:	$\pm 0.9\%$	(For $\chi \geq 3.5MPa$ {35 kgf/cm ² })
		$\pm\left(0.35 + 0.55 \times \frac{3.5}{\chi}\right) \%$	(For $\chi < 3.5MPa$ {35 kgf/cm ² })

Model STH960 (for high temperature and vacuum / high temperature and high vacuum)

Material of wetted parts: Hastelloy C, Tantalum

Flange size: Flush diaphragm 3 in. (80 mm), Extended diaphragm 4 in. (100 mm)

Accuracy (*3)		$\pm 0.2\%$	(For $\chi \geq 3.5MPa$ {35 kgf/cm ² })
		$\pm\left(0.05 + 0.15 \times \frac{3.5}{\chi}\right) \%$	(For $\chi < 3.5MPa$ {35 kgf/cm ² })
Temperature characteristics (Shift from the set range) Change of 30°C (*3) (Range from -5 to 55°C)	Zero shift:	$\pm\left(0.15 + 0.5 \times \frac{3.5}{\chi}\right) \%$	χ : kPa
	Combined shift:	$\pm 0.9\%$	(For $\chi \geq 3.5MPa$ {35 kgf/cm ² })
		$\pm\left(0.35 + 0.55 \times \frac{3.5}{\chi}\right) \%$	(For $\chi < 3.5MPa$ {35 kgf/cm ² })

Note) (*3): Within a range of $XD_SCALE_EU_100 \geq 0$ and $XD_SCALE_EU_0 \geq 0$.

Model STH940 (for high temperature and vacuum / high temperature and high vacuum)

Material of wetted parts: Diaphragm; SUS316L, Others; SUS316

Flange size: Flush diaphragm 2 in. (50 mm) / 1.5 in. (40 mm), Extended diaphragm 3 in. (80 mm) / 2 in. (50 mm)

Accuracy (*3)		$\pm 0.2\%$	(For $\chi \geq 350kPa$ {3.5 kgf/cm ² })
		$\pm\left(0.05 + 0.15 \times \frac{350}{\chi}\right) \%$	(For $\chi < 350kPa$ {3.5 kgf/cm ² })
Temperature characteristics (Shift from the set range) Change of 30°C (*3) (Range from -5 to 55°C)	Zero shift:	$\pm\left(0.15 + 0.45 \times \frac{350}{\chi}\right) \%$	χ : MPa
	Combined shift:	$\pm 0.9\%$	(For $\chi \geq 350kPa$ {3.5 kgf/cm ² })
		$\pm\left(0.35 + 0.55 \times \frac{350}{\chi}\right) \%$	(For $\chi < 350kPa$ {3.5 kgf/cm ² })

Model STH940 (for high temperature and vacuum / high temperature and high vacuum)

Material of wetted parts: Hastelloy C, Tantalum

Flange size: Flush diaphragm 2 in. (50 mm) / 1.5 in. (40 mm)

Accuracy (*3)	Analog mode:	$\pm 0.2\%$	(For $\chi \geq 350kPa$ {3.5 kgf/cm ² })
		$\pm\left(0.05 + 0.15 \times \frac{350}{\chi}\right) \%$	(For $\chi < 350kPa$ {3.5 kgf/cm ² })
Temperature characteristics (Shift from the set range) Change of 30°C (*3) (Range from -5 to 55°C)	Zero shift:	$\pm\left(0.15 + 0.50 \times \frac{350}{\chi}\right) \%$	χ : kPa
	Combined shift:	$\pm 0.9\%$	(For $\chi \geq 350kPa$ {3.5 kgf/cm ² })
		$\pm\left(0.35 + 0.55 \times \frac{350}{\chi}\right) \%$	(For $\chi < 350kPa$ {3.5 kgf/cm ² })

Model STH960 (for high temperature and vacuum / high temperature and high vacuum)

Material of wetted parts: Diaphragm; SUS316L, Others; SUS316

Flange size: Flush diaphragm 2 in. (50 mm) / 1.5 in. (40 mm), Extended diaphragm 3 in. (80 mm) / 2 in.(50 mm)

Accuracy (*3)		$\pm 0.2\%$	(For $\chi \geq 3.5MPa$ {35 kgf/cm ² })
		$\pm\left(0.05 + 0.15 \times \frac{3.5}{\chi}\right) \%$	(For $\chi < 3.5MPa$ {35 kgf/cm ² })
Temperature characteristics (Shift from the set range) Change of 30°C (*3) (Range from -5 to 55°C)	Zero shift:	$\pm\left(0.15 + 0.45 \times \frac{3.5}{\chi}\right) \%$	χ : MPa
	Combined shift:	$\pm 0.9\%$	(For $\chi \geq 3.5MPa$ {35 kgf/cm ² })
		$\pm\left(0.35 + 0.55 \times \frac{3.5}{\chi}\right) \%$	(For $\chi < 3.5MPa$ {35 kgf/cm ² })

Model STH960 (for high temperature and vacuum / high temperature and high vacuum)

Material of wetted parts: Hastelloy C, Tantalum

Flange size: Flush diaphragm 2 in. (50 mm) / 1.5 in. (40 mm)

Accuracy (*3)		0.2%	(For ($\chi \geq 3.5 MPa$ {35 kgf/cm ² })
		$\pm\left(0.05 + 0.15 \times \frac{3.5}{\chi}\right) \%$	(For $\chi < 3.5MPa$ {35 kgf/cm ² })
Temperature characteristics (Shift from the set range) Change of 30°C (*3) (Range from -5 to 55°C)	Zero shift:	$\pm\left(0.15 + 0.50 \times \frac{3.5}{\chi}\right) \%$	χ : MPa
	Combined shift:	$\pm 0.9\%$	(For $\chi \geq 3.5MPa$ {35 kgf/cm ² })
		$\pm\left(0.35 + 0.55 \times \frac{3.5}{\chi}\right) \%$	(For $\chi < 3.5MPa$ {35 kgf/cm ² })

Model STH980 (for regular type and high temperature service)

Material of wetted parts: Diaphragm; SUS316L, Others; SUS316

Flange size: G1½ External screw

Accuracy (*3)		$\pm 0.2\%$	(For $\chi \geq 7MPa$ {70 kgf/cm ² })
		$\pm\left(0.05 + 0.15 \times \frac{7}{\chi}\right) \%$	(For $\chi < 7MPa$ {70 kgf/cm ² })
Temperature characteristics (Shift from the set range) Change of 30°C (*3) (Range from -5 to 55°C)	Zero shift:	$\pm\left(0.15 + 0.45 \times \frac{7}{\chi}\right) \%$	χ : MPa
	Combined shift:	$\pm 1.05\%$	(For $\chi \geq 7MPa$ {70 kgf/cm ² })
		$\pm\left(0.35 + 0.8 \times \frac{7}{\chi}\right) \%$	(For $\chi < 7MPa$ {70 kgf/cm ² })

Note) (*3): Within a range of $XD_SCALE_EU_100 \geq 0$ and $XD_SCALE_EU_0 \geq 0$.

FIELD BUS SPECIFICATIONS**Block supported by the S900**

Name of block	Number of block	Description	Max. execution time msec.
Resource block	1	The Resource Block (RB) maintains overall resources of the S900.	-
Transducer block	1	The Transducer Block (XB) interfaces with the sensing element of the S900, converts the measured value into specified engineering unit, and sends it to the AI Function Block.	-
AI Function Block	2	The AI Function Block (AI FB) accepts an analog input signal from the XB, scales it, detects alarm conditions, and provides it in a uniform format on the Fieldbus network.	75
Diagnostics Block	1	The Diagnostics Block (DB) is Yamatake proprietary block which provides the result of self-diagnostics of the S900.	-
PID Function Block	1	The PID Function Block (PID FB) accepts a process variable (PV) from an AI Function Block on the Fieldbus network, calculates the valve position using the PID algorithm, and sends a new valve output signal to the AO Function Block.	125

VCR structure

The S900 has 16 VCRs (Virtual Communication Relationships), of which the first one is dedicated to the SMIB/NMIB as defined by Foundation Fieldbus specifications. The rest of the VCRs are fully configurable. Their default configurations are shown below:

VCR No.	Configuration	VCR No.	Configuration
1	QUB (Server) for NIMIB/SMIB	9	QUU (Source)
2	BNU (Subscriber)	10	QUU (Source)
3	BNU (Subscriber)	11	QUU (Source)
4	BNU (Subscriber)	12	QUB (Server)
5	BNU (Subscriber)	13	QUB (Server)
6	BNU (Publisher)	14	QUB (Server)
7	BNU (Publisher)	15	QUB (Server)
8	QUU (Source)	16	QUB (Server)

Network parameters

The following table lists the key parameter values that affect the interoperability of the Fieldbus devices. The LAS must be configured to satisfy these parameters. If other devices on the same Fieldbus network require a greater number for them, the greater number must be used. This however will degrade network performance.

Symbol	Parameter name	Range of value
V (ST)	Slot Time	4 to 100
V (MID)	Minimum Interframe Gap	10 to $(V (MRD) - 1) \times V (ST)$, less than 120 inclusive.
V (MRD)	Maximum Response Delay	$V (MRD) \times V (ST)$ shall be greater than 20 and $V (MRD)$ shall be less than 11, inclusive.
T1	SM step timer	96000 (3 seconds)
T2	SM set address sequence timer	1920000 (60 seconds)
T3	SM set address wait timer	480000 (15 seconds)

- Note) • An LAS requires parameters other than those listed here for operation. Please refer to the user's manual that is provided with your LAS device.
 • The T3 must be set between 15 seconds and 60 seconds.

MODEL SELECTION

ST3000 series 900 electric pressure transmitter

Model STH920 / STH940 / STH960 (Remote-sealed diaphragm type for gauge pressure)

Flush diaphragm: 3 in. (80 mm)

for Regular / High-temperature service

Model No.: STH920 - **I II III IV V VI VII VIII** - Option I - Option II

Model No.: STH940 - **I II III IV V VI VII VIII** - Option I - Option II

Model No.: STH960 - **I II III IV V VI VII VIII** - Option I - Option II

Basic Model No.

Measuring span	2.5 to 100 kPa (250 to 10,160 mmH ₂ O)	STH920	Flush diaphragm flange type: 3 in. (80 mm)
	35 to 3500 kPa (0.35 to 35 kgf/cm ²)	STH940	
	0.7 to 10 MPa (7 to 102 kgf/cm ²)	STH960	

Selection I		Model No.	Fill fluid	Code	Fill Fluid Code			
I	Fill fluid			-	1	2	3	5
		STH920 / STH940 / STH960 Flush diaphragm flange type 3 in. (80 mm)	Regular type service (Silicone oil)	1				
			For oxygen service (Fluorine oil) *3	2				
			For high-temperature service (Silicone oil)	3				
			For chlorine service (Fluorine oil) *3	5				
II	Flange standard	ANSI flange		A	✓	✓	✓	✓
		JIS flange		J	✓	✓	✓	✓
		JPI flange		P	✓	✓	✓	✓
III	Flange type & Rating	JIS 10K, ANSI/JPI 150 (RF) equivalent		A	✓	✓	✓	✓
		JIS 20K, ANSI/JPI 300 (RF) equivalent		B	✓	✓	✓	✓
		JIS 30K, ANSI/JPI 600 (RF) equivalent		C	✓	✓	✓	✓
IV	Flange material	SUS304		7	✓	✓	✓	✓
		SUS316		2	✓	✓	✓	✓
		SUS316L		8	✓	✓	✓	✓
V	Material of wetted parts	SUS316 (Diaphragm: SUS316L, others: SUS316)		2	✓	✓	✓	
		SUS316L (Diaphragm: SUS316L, others: SUS316L)		8	✓	✓	✓	
		Tantalum (Diaphragm: Tantalum, others: Tantalum) *17		4	✓	✓	✓	✓
		Hastelloy C (Diaphragm: Hastelloy C, others: Hastelloy C)		9	✓	✓	✓	
VI	Finish of gasket face	Standard (JIS Ra3.2 (12.5S))		J	✓	✓	✓	✓
VII	Length of extended parts	Flush diaphragm 3 in. (80 mm)		00	✓	✓	✓	✓
VIII	Length of capillary tube	2 m		2	✓	✓	✓	✓
		3 m		3	✓	✓	✓	✓
		4 m		4	✓	✓	✓	✓
		5 m		5	✓	✓	✓	✓
		6 m		6	✓	✓	✓	✓
		7 m		7	✓	✓	✓	✓
		8 m		8	✓	✓	✓	✓
		9 m		9	✓	✓	✓	✓
		10 m		A	✓	✓	✓	✓
		Length of capillary tube with olefin coating	2 m		B	✓	✓	✓
	3 m			C	✓	✓	✓	✓
	4 m			H	✓	✓	✓	✓
	5 m			D	✓	✓	✓	✓
	6 m			J	✓	✓	✓	✓
	7 m			E	✓	✓	✓	✓
	8 m			F	✓	✓	✓	✓
	9 m			K	✓	✓	✓	✓
	10 m		G	✓	✓	✓	✓	

(Continued)

(Continued from previous page)

Model No.: STH920 - I II III IV V VI VII VIII - **Option I - Option II**Model No.: STH940 - I II III IV V VI VII VIII - **Option I - Option II**Model No.: STH960 - I II III IV V VI VII VIII - **Option I - Option II**

		Code	Fill Fluid Code			
		-	1	2	3	5
Options I	No options	X	✓	✓	✓	✓
	Built-in indicating smart meter (0 to 100% liner scales)	P	✓	✓	✓	✓
	Built-in indicating smart meter (engineering unit scales)	R	✓	✓	✓	✓
	SUS304 bolt and nuts material	W	✓	✓	✓	✓
	SUS630 bolt and nuts material	U	✓	✓	✓	✓
	Corrosion-resistant finish	A	✓	✓	✓	✓
	Corrosion-proof finish	B	✓	✓	✓	✓
	Corrosion-resistant finish, silver paint	D	✓	✓	✓	✓
	Oil free finish	K	✓	✓	✓	✓
	FEP protective film	T	✓	✓		✓
	FM Explosionproof	3	✓	✓	✓	✓
	ATEX Flameproof	6	✓	✓	✓	✓
		-				
Options II	No option	XX	✓	✓	✓	✓
	Water free finish (with oil free finish)	A7	✓	✓	✓	✓
	NEPSI Flameproof	C1	✓	✓	✓	✓
	Custom calibration	C7	✓	✓	✓	✓
	FOUNDATION™ fieldbus *33	D6	✓	✓	✓	✓
	One elbow	E1	✓	✓	✓	✓
	Two elbows	E2	✓	✓	✓	✓
	Mounting bracket	E9	✓	✓	✓	✓
	0.1 mm thickness diaphragm *15	F4	✓	✓	✓	✓
	Material certificate	H2	✓	✓	✓	✓
	Fieldbus communication stack BASIC class (used with option D6) *33	L1	✓	✓	✓	✓
	SI unit	U1	✓	✓	✓	✓

Note) *3 In case “for oxygen or chlorine (fluorine oil) service” is used, “oil free finish - code K” must be selected.

*15 Only available for material of wetted parts: “SUS316” and “SUS316L”.

*17 In case “Tantalum” is used for diaphragm material and in case of “for high-temperature service”, normal operating conditions of meter body (process fluid) temperature is -10 to +180°C

*33 “FOUNDATION™ fieldbus - code D6” and “Fieldbus communication stack BASIC class - code L1” must be selected.

ST3000 series 900 electric pressure transmitter
Model STH940 / STH960 (Remote-sealed diaphragm type)
Flush diaphragm: 2 in. (50 mm), 1.5 in. (40 mm)
for Regular / High-temperature service

Model No.: STH940 - **I II III IV V VI VII VIII** - Option I - Option II

Model No.: STH960 - **I II III IV V VI VII VIII** - Option I - Option II

Basic Model No.

	Measuring span	35 to 3500 kPa (0.35 to 35 kgf/cm ²)	STH940	Flush diaphragm flange type: 2 in. (50 mm), 1.5 in. (40 mm)
		0.7 to 10 MPa (7 to 102 kgf/cm ²)	STH960	

Selection I			Code	Fill Fluid Code				
I	Fill fluid	Model No.	Fill fluid	-	1	2	3	5
		STH940 / STH960 Flush diaphragm flange type 2 in. (50 mm), 1.5 in. (40 mm)	Regular type service (Silicone oil)	1				
			For oxygen service (Fluorine oil) *3	2				
			For high-temperature service (Silicone oil)	3				
			For chlorine service (Fluorine oil) *3	5				
II	Flange standard	ANSI flange		A	✓	✓	✓	✓
		JIS flange		J	✓	✓	✓	✓
		JPI flange		P	✓	✓	✓	✓
III	Flange type & Rating	JIS 10K, ANSI/JPI 150 (RF) equivalent		A	✓	✓	✓	✓
		JIS 20K, ANSI/JPI 300 (RF) equivalent		B	✓	✓	✓	✓
		JIS 30K, ANSI/JPI 600 (RF) equivalent		C	✓	✓	✓	✓
IV	Flange material	SUS304		7	✓	✓	✓	✓
		SUS316		2	✓	✓	✓	✓
		SUS316L		8	✓	✓	✓	✓
V	Material of wetted Parts	SUS316 (Diaphragm: SUS316L, others: SUS316)		2	✓	✓	✓	
		SUS316L (Diaphragm SUS316L, others: SUS316L) *17		8	✓	✓	✓	
		Tantalum (Diaphragm: Tantalum, others: Tantalum) *27		4	✓	✓		✓
		Hastelloy C (Diaphragm: Hastelloy C, others: Hastelloy C)		9	✓	✓	✓	
VI	Finish of gasket face	Standard (JIS Ra3.2 (12.5S))		J	✓	✓	✓	✓
VII	Length of extended parts	Flush diaphragm 2 in. (50 mm)		01	✓	✓	✓	✓
		Flush diaphragm 1.5 in. (40 mm)		02	✓	✓	✓	✓
VIII	Length of capillary tube	2 m		2	✓	✓	✓	✓
		3 m		3	✓	✓	✓	✓
		4 m		4	✓	✓	✓	✓
		5 m		5	✓	✓	✓	✓
	Length of capillary tube with olefin coating	2 m		B	✓	✓	✓	✓
		3 m		C	✓	✓	✓	✓
		4 m		H	✓	✓	✓	✓
		5 m		D	✓	✓	✓	✓

(Continued)

(Continued from previous page)

Model No.: STH940 - I II III IV V VI VII VIII - Option I - Option II

Model No.: STH960 - I II III IV V VI VII VIII - Option I - Option II

		Code	Fill Fluid Code			
		-	1	2	3	5
Options I	No options	X	✓	✓	✓	✓
	Built-in indicating smart meter (0 to 100% liner scales)	P	✓	✓	✓	✓
	Built-in indicating smart meter (engineering unit scales)	R	✓	✓	✓	✓
	SUS304 bolt and nuts material	W	✓	✓	✓	✓
	SUS630 bolt and nuts material	U	✓	✓	✓	✓
	Corrosion-resistant finish	A	✓	✓	✓	✓
	Corrosion-proof finish	B	✓	✓	✓	✓
	Corrosion-resistant finish, silver paint	D	✓	✓	✓	✓
	Oil free finish	K	✓	✓	✓	✓
	FEP protective film	T	✓	✓		✓
	FM Explosionproof	3	✓	✓	✓	✓
	ATEX Flameproof	6	✓	✓	✓	✓
			-			
Options II	No option	XX	✓	✓	✓	✓
	Water free finish (with oil free finish)	A7	✓	✓	✓	✓
	NEPSI Flameproof	C1	✓	✓	✓	✓
	Custom calibration	C7	✓	✓	✓	✓
	FOUNDATION™ fieldbus *33	D6	✓	✓	✓	✓
	One elbow	E1	✓	✓	✓	✓
	Two elbows	E2	✓	✓	✓	✓
	Mounting bracket	E9	✓	✓	✓	✓
	Material certificate	H2	✓	✓	✓	✓
	Fieldbus communication stack BASIC class (used with option D6) *33	L1	✓	✓	✓	✓
	SI unit	U1	✓	✓	✓	✓

Note) *3 In case “for oxygen or chlorine (fluorine oil) service” is used, “oil free finish - code K” must be selected.

*17 In case “Tantalum” is used for diaphragm material and in case of “for high-temperature service”, normal operating conditions of meter body (process fluid) temperature is -10 to +180°C

*27 In case “Tantalum” is used for diaphragm material and flange size is 1.5 in., fill fluid “for high-temperature service” is not applicable and only 2 m and 3 m are available for capillary length.

*33 “FOUNDATION™ fieldbus - code D6” and “Fieldbus communication stack BASIC class - code L1” must be selected.

ST3000 series 900 electric pressure transmitter
Model STH920 / STH940 / STH960 (Remote-sealed diaphragm type)
Extended diaphragm: 4 in. (100 mm)
for Regular / High-temperature service

Model No.: STH920 - **I II III IV V VI VII VIII** - Option I - Option II

Model No.: STH940 - **I II III IV V VI VII VIII** - Option I - Option II

Model No.: STH960 - **I II III IV V VI VII VIII** - Option I - Option II

Basic Model No.

Measuring span	2.5 to 100 kPa (250 to 10,160 mmH ₂ O)	STH920	Extended diaphragm flange type: 4 in. (100 mm)
	35 to 3500 kPa (0.35 to 35 kgf/cm ²)	STH940	
	0.7 to 10 MPa (7 to 102 kgf/cm ²)	STH960	

Selection I		Code	Fill fluid code			
			1	2	3	
I	Fill fluid	Model No.				
		STH920 / STH940 / STH960	Regular type service (Silicone oil)	1		
		Extended diaphragm flange type 4 in. (100 mm)	For oxygen service (Fluorine oil) *3	2		
		For high-temperature service (Silicone oil) *19 *20	3			
II	Flange standard	ANSI flange	A	✓	✓	✓
		JIS flange	J	✓	✓	✓
		JPI flange	P	✓	✓	✓
III	Flange type & rating	JIS 10K, ANSI/JPI 150 (RF) equivalent	A	✓	✓	✓
		JIS 20K, ANSI/JPI 300 (RF) equivalent *19	B	✓	✓	✓
		JIS 30K, ANSI/JPI 600 (RF) equivalent *16 *20	C	✓	✓	✓
IV	Flange material	SUS304	7	✓	✓	✓
		SUS316	2	✓	✓	✓
		SUS316L *16 *20	8	✓	✓	✓
V	Material of wetted parts	SUS316 (Diaphragm: SUS316L, others: SUS316)	2	✓	✓	✓
		SUS316L (Diaphragm: SUS316L, others: SUS316L) *16 *19 *20	8	✓	✓	✓
VI	Finish of gasket face	Standard (JIS Ra3.2 (12.5S))	J	✓	✓	✓
VII	Length of extended parts	L = 50 mm (4 in. / 100 mm) *20	09	✓	✓	✓
		L = 100 mm (4 in. / 100 mm) *20	14	✓	✓	✓
		L = 150 mm (4 in. / 100 mm) *16 *20	19	✓	✓	✓
		L = 200 mm (4 in. / 100 mm) *16 *20	24	✓	✓	✓
		L = 250 mm (4 in. / 100 mm) *16 *19 *20	29	✓	✓	✓
		L = 300 mm (4 in. / 100 mm) *16 *19 *20	34	✓	✓	✓
VIII	Length of capillary tube	2 m	2	✓	✓	✓
		3 m	3	✓	✓	✓
		4 m	4	✓	✓	✓
		5 m	5	✓	✓	✓
		6 m	6	✓	✓	✓
		7 m	7	✓	✓	✓
		8 m	8	✓	✓	✓
		9 m	9	✓	✓	✓
		10 m	A	✓	✓	✓
		Length of capillary tube with olefin coating	2 m	B	✓	✓
	3 m		C	✓	✓	✓
	4 m		H	✓	✓	✓
	5 m		D	✓	✓	✓
	6 m		J	✓	✓	✓
	7 m		E	✓	✓	✓
	8 m		F	✓	✓	✓
	9 m		K	✓	✓	✓
	10 m	G	✓	✓	✓	

(Continued)

(Continued from previous page)

Model No.: STH920 - I II III IV V VI VII VIII - Option I - Option II

Model No.: STH940 - I II III IV V VI VII VIII - Option I - Option II

Model No.: STH960 - I II III IV V VI VII VIII - Option I - Option II

		Code	Fill fluid code		
		-	1	2	3
Options I	No options	X	✓	✓	✓
	Built-in indicating smart meter (0 to 100% liner scales)	P	✓	✓	✓
	Built-in indicating smart meter (engineering unit scales)	R	✓	✓	✓
	SUS304 bolt and nuts material	W	✓	✓	✓
	SUS630 bolt and nuts material	U	✓	✓	✓
	Corrosion-resistant finish	A	✓	✓	✓
	Corrosion-proof finish	B	✓	✓	✓
	Corrosion-resistant finish, silver paint	D	✓	✓	✓
	Oil free finish	K	✓	✓	✓
	FM Explosionproof	3	✓	✓	
	ATEX Flameproof	6	✓	✓	✓
			-		
Options II	No option	XX	✓	✓	✓
	Water free finish (with oil free finish)	A7	✓	✓	✓
	NEPSI Flameproof	C1	✓	✓	✓
	Custom calibration	C7	✓	✓	✓
	FOUNDATION™ fieldbus *33	D6	✓	✓	✓
	One elbow	E1	✓	✓	✓
	Two elbows	E2	✓	✓	✓
	Mounting bracket	E9	✓	✓	✓
	0.1 mm thickness diaphragm	F4	✓	✓	✓
	Material certificate	H2	✓	✓	✓
	Fieldbus communication stack BASIC class (used with option D6) *33	L1	✓	✓	✓
	SI unit	U1	✓	✓	✓

Note) *3 In case “for oxygen or chlorine (fluorine oil) service” is used, “oil free finish - code K” must be selected.

*16 In case “JIS30K” is used for flange type and rating, “SUS316L” is used for flange material and for regular service or oxygen service, not available for length of extended parts: 150 / 200 / 250 / 300 mm

*19 In case fill fluid: for high-temperature service and flange rating: ANSI 300 and wetted parts material: SUS316L, extension length of flange 250 / 300 mm are not available.

*20 In case flange rating: JIS 30K and wetted parts material: SUS316L, and for high temperature service, extended diaphragm type is not available.

*33 “FOUNDATION™ fieldbus - code D6” and “Fieldbus communication stack BASIC class - code L1” must be selected.

ST3000 series 900 electric pressure transmitter
Model STH940 / STH960 (Remote-sealed diaphragm type)
Extended diaphragm: 3 in. (80 mm), 2 in. (50 mm)
for Regular / High-temperature service

Model No.: STH940 - **I II III IV V VI VII VIII** - Option I - Option II

Model No.: STH960 - **I II III IV V VI VII VIII** - Option I - Option II

Basic Model No.

	Measuring span	35 to 3500 kPa (0.35 to 35 kgf/cm ²)	STH940	Extended diaphragm flange type: 3 in. (80 mm), 2 in. (50 mm)
		0.7 to 10 MPa (7 to 102 kgf/cm ²)	STH960	

Selection I			Code	Fill fluid code			
I	Fill fluid	Model No.	Fill fluid	-	1	2	3
		STH940 / STH960	Regular type service (Silicone oil)	1			
		Extended diaphragm flange type 3 in. (80 mm), 2 in. (50 mm)	For oxygen service (Fluorine oil) *3	2			
			For high-temperature service (Silicone oil) *31	3			
II	Flange standard	ANSI flange	A	✓	✓	✓	
		JIS flange	J	✓	✓	✓	
		JPI flange	P	✓	✓	✓	
III	Flange type & Rating	JIS 10K, ANSI/JPI 150 (RF) equivalent	A	✓	✓	✓	
		JIS 20K, ANSI/JPI 300 (RF) equivalent	B	✓	✓	✓	
		JIS 30K, ANSI/JPI 600 (RF) equivalent *24 *31	C	✓	✓	✓	
IV	Flange material	SUS304	7	✓	✓	✓	
		SUS316	2	✓	✓	✓	
		SUS316L	8	✓	✓	✓	
V	Material of wetted Parts	SUS316 (Diaphragm: SUS316L, others: SUS316)	2	✓	✓	✓	
		SUS316L (Diaphragm: SUS316L, others: SUS316L) *31	8	✓	✓	✓	
VI	Finish of gasket face	Standard (JIS Ra3.2 (12.5S))	J	✓	✓	✓	
VII	Length of extended parts	L = 50 mm (3 in. / 80 mm) *24	05	✓	✓	✓	
		L = 100 mm (3 in. / 80 mm) *24	10	✓	✓	✓	
		L = 150 mm (3 in. / 80 mm) *24	15	✓	✓	✓	
		L = 200 mm (3 in. / 80 mm) *24	20	✓	✓	✓	
		L = 250 mm (3 in. / 80 mm) *24	25	✓	✓	✓	
		L = 300 mm (3 in. / 80 mm) *24	30	✓	✓	✓	
		L = 50 mm (2 in. / 50 mm) *24	06	✓	✓	✓	
		L = 100 mm (2 in. / 50 mm) *24	11	✓	✓	✓	
		L = 150 mm (2 in. / 50 mm) *24	16	✓	✓	✓	
		L = 200 mm (2 in. / 50 mm) *24 *31	21	✓	✓	✓	
		L = 250 mm (2 in. / 50 mm) *24 *31	26	✓	✓	✓	
		L = 300 mm (2 in. / 50 mm) *24 *31	31	✓	✓	✓	
VIII	Length of capillary tube	2 m	2	✓	✓	✓	
		3 m	3	✓	✓	✓	
		4 m	4	✓	✓	✓	
		5 m	5	✓	✓	✓	
	Length of capillary tube with olefin coating	2 m	B	✓	✓	✓	
		3 m	C	✓	✓	✓	
		4 m	H	✓	✓	✓	
		5 m	D	✓	✓	✓	

(Continued)

(Continued from previous page)

Model No.: STH940 - I II III IV V VI VII VIII - Option I - Option II

Model No.: STH960 - I II III IV V VI VII VIII - Option I - Option II

		Code	Fill fluid code		
		-	1	2	3
Options I	No options	X	✓	✓	✓
	Built-in indicating smart meter (0 to 100% liner scales)	P	✓	✓	✓
	Built-in indicating smart meter (engineering unit scales)	R	✓	✓	✓
	SUS304 bolt and nuts material	W	✓	✓	✓
	SUS630 bolt and nuts material	U	✓	✓	✓
	Corrosion-resistant finish	A	✓	✓	✓
	Corrosion-proof finish	B	✓	✓	✓
	Corrosion-resistant finish, silver paint	D	✓	✓	✓
	Oil free finish	K	✓	✓	✓
	FM Explosionproof	3	✓	✓	✓
	ATEX Flameproof	6	✓	✓	✓
		-			
Options II	No option	XX	✓	✓	✓
	Water free finish (with oil free finish)	A7	✓	✓	✓
	NEPSI Flameproof	C1	✓	✓	✓
	Custom calibration	C7	✓	✓	✓
	FOUNDATION™ fieldbus *33	D6	✓	✓	✓
	One elbow	E1	✓	✓	✓
	Two elbows	E2	✓	✓	✓
	Mounting bracket	E9	✓	✓	✓
	Material certificate	H2	✓	✓	✓
	Fieldbus communication stack BASIC class (used with option D6) *33	L1	✓	✓	✓
	SI unit	U1	✓	✓	✓

Note) *3 In case “for oxygen or chlorine (fluorine oil) service” is used, “oil free finish - code K” must be selected.

*24 In case of “ANSI / JPI 600” is used for 3 in. flange type and rating, not available for the extended diaphragm flange type.

*31 In case fill fluid: for high-temperature service, for high-temperature vacuum service or high-temperature high vacuum service and 2 in. flange rating: ANSI / JPI 600 and wetted parts material: SUS316L, extension length of flange 200 / 250 / 300 mm are not available.

*33 “FOUNDATION™ fieldbus - code D6” and “Fieldbus communication stack BASIC class - code L1” must be selected.

ST3000 series 900 electric pressure transmitter
Model STH940 / STH960 (Remote-sealed diaphragm type for gauge pressure)
Flush diaphragm: 3 in. (80 mm)

for High-temperature / Vacuum, high-temperature / High-vacuum service

Model No.: STH940 - **I II III IV V VI VII VIII** - Option I - Option II

Model No.: STH960 - **I II III IV V VI VII VIII** - Option I - Option II

Basic Model No.

	Measuring span	35 to 3500 kPa (0.35 to 35 kgf/cm ²)	STH940	Flush diaphragm flange type: 3 in. (80 mm)
		0.7 to 10 MPa (7 to 102 kgf/cm ²)	STH960	

Selection I			Code	Fill fluid code	
I	Fill fluid	Model No.	-	4	7
		STH940 / STH960 Flush diaphragm flange type 3 in.(80 mm)	For high-temperature vacuum service (silicone oil)	4	
			For high-temperature high vacuum service (silicone oil)	7	
II	Flange standard	ANSI flange	A	✓	✓
		JIS flange	J	✓	✓
		JPI flange	P	✓	✓
III	Flange type & Rating	JIS 10K, ANSI/ JPI 150 (RF) equivalent	A	✓	✓
		JIS 20K, ANSI/ JPI 300 (RF) equivalent	B	✓	✓
		JIS 30K, ANSI/ JPI 600 (RF) equivalent	C	✓	✓
IV	Flange material	SUS304	7	✓	✓
		SUS316	2	✓	✓
		SUS316L	8	✓	✓
V	Material of wetted Parts	SUS316L (Diaphragm:SUS316L, others: SUS316L)	8	✓	✓
		Tantalum (Diaphragm: Tantalum, others: Tantalum) *17	4	✓	✓
		Hastelloy C (Diaphragm: Hastelloy C, others: Hastelloy C)	9	✓	✓
VI	Finish of gasket face	Standard (JIS Ra3.2 (12.5S))	J	✓	✓
VII	Length of extended parts	Flush diaphragm 3 in. (80 mm)	00	✓	✓
VIII	Length of capillary tube	2 m	2	✓	✓
		3 m	3	✓	✓
		4 m	4	✓	✓
		5 m	5	✓	✓
		6 m	6	✓	✓
		7 m	7	✓	✓
		8 m	8	✓	✓
		9 m	9	✓	✓
		10 m	A	✓	✓

(Continued)

(Continued from previous page)

Model No.: STH940 - I II III IV V VI VII VIII - **Option I - Option II**Model No.: STH960 - I II III IV V VI VII VIII - **Option I - Option II**

		Code	Fill fluid code	
		-	4	7
Options I	No options	X	✓	✓
	Built-in indicating smart meter (0 to 100% liner scales)	P	✓	✓
	Built-in indicating smart meter (engineering unit scales)	R	✓	✓
	SUS304 bolt and nuts material	W	✓	✓
	SUS630 bolt and nuts material	U	✓	✓
	Corrosion-resistant finish	A	✓	✓
	Corrosion-proof finish	B	✓	✓
	Corrosion-resistant finish, silver paint	D	✓	✓
	Oil free finish	K	✓	✓
	FM Explosionproof	3	✓	✓
	ATEX Flameproof	6	✓	✓
			-	
Options II	No option	XX	✓	✓
	Water free finish (with oil free finish)	A7	✓	✓
	NEPSI Flameproof	C1	✓	✓
	Custom calibration	C7	✓	✓
	FOUNDATION™ fieldbus *33	D6	✓	✓
	One elbow	E1	✓	✓
	Two elbows	E2	✓	✓
	Mounting bracket	E9	✓	✓
	Material certificate	H2	✓	✓
	Fieldbus communication stack BASIC class (used with option D6) *33	L1	✓	✓
	SI unit	U1	✓	✓

Note) *17 In case "Tantalum" is used for diaphragm material and in case of "for high-temperature service", normal operating conditions of meter body (process fluid) temperature is -10 to +180°C

*33 "FOUNDATION™ fieldbus - code D6" and "Fieldbus communication stack BASIC class - code L1" must be selected.

ST3000 Series 900 electric pressure transmitter
Model STH940 / STH960 (Remote-sealed diaphragm type)
Flush diaphragm: 2 in. (50 mm), 1.5 in. (40 mm)
for High-temperature / Vacuum, high-temperature / High-vacuum service

Model No.: STH940 - I II III IV V VI VII VIII - Option I - Option II

Model No.: STH960 - I II III IV V VI VII VIII - Option I - Option II

Basic Model No.

	Measuring span	35 to 3500 kPa (0.35 to 35 kgf/cm ²)	STH940	Flush diaphragm flange type: 2 in. (50 mm), 1.5 in. (40 mm)
		0.7 to 10 MPa (7 to 102 kgf/cm ²)	STH960	

Selection I			Code	Fill fluid code		
I	Fill fluid	Model No.	Fill fluid	-	4	7
		STH940 / STH960 Flush diaphragm flange type 2 in.(50 mm), 1.5 in. (40 mm)	For high-temperature vacuum service (silicone oil)	4		
			For high-temperature high vacuum service (silicone oil)	7		
II	Flange standard	ANSI flange		A	✓	✓
		JIS flange		J	✓	✓
		JPI flange		P	✓	✓
III	Flange type & Rating	JIS 10K, ANSI/ JPI 150 (RF) equivalent		A	✓	✓
		JIS 20K, ANSI/ JPI 300 (RF) equivalent		B	✓	✓
		JIS 30K, ANSI/ JPI 600 (RF) equivalent		C	✓	✓
IV	Flange material	SUS304		7	✓	✓
		SUS316		2	✓	✓
		SUS316L		8	✓	✓
V	Material of wetted parts	SUS316L (Diaphragm: SUS316L, others: SUS316L)		8	✓	✓
		Tantalum (Diaphragm: Tantalum, others: Tantalum) *17		4	✓	✓
		Hastelloy C (Diaphragm: Hastelloy C, others: Hastelloy C)		9	✓	✓
VI	Finish of gasket face	Standard (JIS Ra3.2 (12.5S))		J	✓	✓
VII	Length of extended parts	Flush diaphragm 2 in. (50 mm)		01	✓	✓
		Flush diaphragm 1.5 in. (40 mm)		02	✓	✓
VIII	Length of capillary tube	2 m		2	✓	✓
		3 m		3	✓	✓
		4 m		4	✓	✓
		5 m		5	✓	✓

(Continued)

(Continued from previous page)

Model No.: STH940 - I II III IV V VI VII VIII - Option I - Option II

Model No.: STH960 - I II III IV V VI VII VIII - Option I - Option II

		Code	Fill fluid code	
		-	4	7
Options I	No options	X	✓	✓
	Built-in indicating smart meter (0 to 100% liner scales)	P	✓	✓
	Built-in indicating smart meter (engineering unit scales)	R	✓	✓
	SUS304 Bolt and nuts material	W	✓	✓
	SUS630 Bolt and nuts material	U	✓	✓
	Corrosion-resistant finish	A	✓	✓
	Corrosion-proof finish	B	✓	✓
	Corrosion-resistant finish, silver paint	D	✓	✓
	Oil free finish	K	✓	✓
	FM Explosionproof	3	✓	✓
	ATEX Flameproof	6	✓	✓
			-	
Options II	No option	XX	✓	✓
	Water free finish (with oil free finish)	A7	✓	✓
	NEPSI Flameproof	C1	✓	✓
	Custom calibration	C7	✓	✓
	FOUNDATION™ fieldbus *33	D6	✓	✓
	One elbow	E1	✓	✓
	Two elbows	E2	✓	✓
	Mounting bracket	E9	✓	✓
	Material certificate	H2	✓	✓
	Fieldbus communication stack BASIC class (used with option D6) *33	L1	✓	✓
	SI unit	U1	✓	✓

Note) *17 In case "Tantalum" is used for diaphragm material and in case of "for high-temperature service", normal operating conditions of meter body (process fluid) temperature is -10 to +180°C

*33 "FOUNDATION™ fieldbus - code D6" and "Fieldbus communication stack BASIC class - code L1" must be selected.

ST3000 series 900 electric pressure transmitter
Model STH940 / STH960 (Remote-sealed diaphragm type)
Extended diaphragm: 4 in. (100 mm)
for High-temperature / Vacuum, high-temperature / High-vacuum service

Model No.: STH940 - I II III IV V VI VII VIII - Option I - Option II

Model No.: STH960 - I II III IV V VI VII VIII - Option I - Option II

Basic Model No.

	Measuring span	35 to 3500 kPa (0.35 to 35 kgf/cm ²)	STH940	Extended diaphragm flange type: 4 in. (100 mm)
		0.7 to 10 MPa (7 to 102 kgf/cm ²)	STH960	

Selection I			Code	Fill fluid code		
I	Fill fluid	Model No.	Fill fluid	-	4	7
		STH940 / STH960 Extended diaphragm flange type 4 in. (100 mm)	For high-temperature vacuum service (silicone oil)	4		
			For high-temperature high vac- uum service (silicone oil)	7		
II	Flange standard	ANSI flange		A	✓	✓
		JIS flange		J	✓	✓
		JPI flange		P	✓	✓
III	Flange type & rating	JIS 10K, ANSI/JPI 150 (RF) equivalent		A	✓	✓
		JIS 20K, ANSI/JPI 300 (RF) equivalent *23		B	✓	✓
		JIS 30K, ANSI/JPI 600 (RF) equivalent *20 *24		C	✓	✓
IV	Flange material	SUS304		7	✓	✓
		SUS316		2	✓	✓
		SUS316L *20 *23		8	✓	✓
V	Material of wetted parts	SUS316 (Diaphragm: SUS316L, others: SUS316)		2	✓	✓
		SUS316L (Diaphragm: SUS316L, others: SUS316L)		8	✓	✓
VI	Finish of gasket face	Standard (JIS Ra3.2 (12.5S))		J	✓	✓
VII	Length of extended parts	L = 50 mm (4in. / 100 mm) *24		09	✓	✓
		L = 100 mm (4in. / 100 mm) *24		14	✓	✓
		L = 150 mm (4in. / 100 mm) *24		19	✓	✓
		L = 200 mm (4in. / 100 mm) *23 *24		24	✓	✓
		L = 250 mm (4in. / 100 mm) *23 *24		29	✓	✓
		L = 300 mm (4in. / 100 mm) *23 *24		34	✓	✓
VIII	Length of capillary tube	2 m		2	✓	✓
		3 m		3	✓	✓
		4 m		4	✓	✓
		5 m		5	✓	✓
		6 m		6	✓	✓
		7 m		7	✓	✓
		8 m		8	✓	✓
		9 m		9	✓	✓
		10 m		A	✓	✓

(Continued)

(Continued from previous page)

Model No.: STH940 - I II III IV V VI VII VIII - Option I - Option II

Model No.: STH960 - I II III IV V VI VII VIII - Option I - Option II

		Code	Fill fluid code	
		-	4	7
Options I	No options	X	✓	✓
	Built-in indicating smart meter (0 to 100% liner scales)	P	✓	✓
	Built-in indicating smart meter (engineering unit scales)	R	✓	✓
	SUS304 bolt and nuts material	W	✓	✓
	SUS630 bolt and nuts material	U	✓	✓
	Corrosion-resistant finish	A	✓	✓
	Corrosion-proof finish	B	✓	✓
	Corrosion-resistant finish, silver paint	D	✓	✓
	Oil free finish	K	✓	✓
	FM Explosionproof	3	✓	✓
	ATEX Flameproof	6	✓	✓
			-	
Options II	No option	XX	✓	✓
	Water free finish (with oil free finish)	A7	✓	✓
	NEPSI Flameproof	C1	✓	✓
	Custom calibration	C7	✓	✓
	FOUNDATION™ fieldbus *33	D6	✓	✓
	One elbow	E1	✓	✓
	Two elbows	E2	✓	✓
	Mounting bracket	E9	✓	✓
	Material certificate	H2	✓	✓
	Fieldbus communication stack BASIC class (used with option D6) *33	L1	✓	✓
	SI unit	U1	✓	✓

- Note) *20 In case flange rating: JIS 30K, wetted parts material: SUS316L and for high temperature service, extended diaphragm type is not available.
- *23 In case "ANSI / JPI 300" is used for flange type & rating, not available for length of extended parts: 200 / 250 / 300 mm.
- *24 In case of "ANSI / JPI 600" is used for 3 in. flange type and rating, not available for the extended diaphragm flange type.
- *33 "FOUNDATION™ fieldbus - code D6" and "Fieldbus communication stack BASIC class - code L1" must be selected.

ST3000 series 900 electric pressure transmitter
Model STH940 / STH960 (Remote-sealed diaphragm type)
Extended diaphragm: 3 in. (80 mm), 2 in. (50 mm)
for High-temperature / Vacuum, high-temperature / High-vacuum service

Model No.: STH940 - I II III IV V VI VII VIII - Option I - Option II

Model No.: STH960 - I II III IV V VI VII VIII - Option I - Option II

Basic Model No.

	Measuring span	35 to 3500 kPa(0.35 to 35 kgf/cm ²)	STH940	Extended diaphragm flange type: 3 in. (80 mm), 2 in. (50 mm)
		0.7 to 10 MPa (7 to 102 kgf/cm ²)	STH960	

Selection I			Code	Fill fluid code		
I	Fill fluid	Model No.	-	4	7	
		STH940 / STH960 Extended diaphragm flange type 3 in. (80 mm), 2 in. (50 mm)	For high-temperature vacuum service (silicone oil)	4		
			For high-temperature high vacuum service (silicone oil)	7		
II	Flange standard	ANSI flange	A	✓	✓	
		JIS flange	J	✓	✓	
		JPI flange	P	✓	✓	
III	Flange type & Rating	JIS 10K, ANSI/ JPI 150 (RF) equivalent	A	✓	✓	
		JIS 20K, ANSI/ JPI 300 (RF) equivalent	B	✓	✓	
		JIS 30K, equivalent *24 *32	C	✓	✓	
IV	Flange material	SUS304	7	✓	✓	
		SUS316	2	✓	✓	
		SUS316L *32	8	✓	✓	
V	Material of wetted parts	SUS316 (Diaphragm: SUS316L, others: SUS316)	2	✓	✓	
		SUS316L (Diaphragm:SUS316L, others: SUS316L)	8	✓	✓	
VI	Finish of gasket face	Standard (JIS Ra3.2 (12.5S))	J	✓	✓	
VII	Length of extended parts	L = 50 mm (3 in. / 80 mm) *24	05	✓	✓	
		L = 100 mm (3 in. / 80 mm) *24	10	✓	✓	
		L = 150 mm (3 in. / 80 mm) *24	15	✓	✓	
		L = 50 mm (2 in. / 50 mm) *24	06	✓	✓	
		L = 100 mm (2 in. / 50 mm) *24	11	✓	✓	
		L = 150 mm (2 in. / 50 mm) *24	16	✓	✓	
VIII	Length of capillary tube	2 m	2	✓	✓	
		3 m	3	✓	✓	
		4 m	4	✓	✓	
		5 m	5	✓	✓	

(Continued)

(Continued from previous page)

Model No.: STH940 - I II III IV V VI VII VIII - Option I - Option II

Model No.: STH960 - I II III IV V VI VII VIII - Option I - Option II

		Code	Fill fluid code	
		-	4	7
Options I	No options	X	✓	✓
	Built-in indicating smart meter (0 to 100% liner scales)	P	✓	✓
	Built-in indicating smart meter (engineering unit scales)	R	✓	✓
	SUS304 bolt and nuts material	W	✓	✓
	SUS630 bolt and nuts material	U	✓	✓
	Corrosion-resistant finish	A	✓	✓
	Corrosion-proof finish	B	✓	✓
	Corrosion-resistant finish, silver paint	D	✓	✓
	Oil free finish	K	✓	✓
	FM Explosionproof	3	✓	✓
	ATEX Flameproof	6	✓	✓
		-		
Options II	No option	XX	✓	✓
	Water free finish (with oil free finish)	A7	✓	✓
	NEPSI Flameproof	C1	✓	✓
	Custom calibration	C7	✓	✓
	FOUNDATION™ fieldbus *33	D6	✓	✓
	One elbow	E1	✓	✓
	Two elbows	E2	✓	✓
	Mounting bracket	E9	✓	✓
	Material certificate	H2	✓	✓
	Fieldbus communication stack BASIC class (used with option D6) *33	L1	✓	✓
	SI unit	U1	✓	✓

Note) *24 In case of "ANSI / JPI 600" is used 3 in. flange type and rating, not available for the extended diaphragm flange type.

*32 In case flange rating: JIS 30K, flange material: SUS316L is not available.

*33 "FOUNDATION™ fieldbus - code D6" and "Fieldbus communication stack BASIC class - code L1" must be selected.

ST3000 series 900 electric pressure transmitter
Model STH960 / STH980 (Remote-sealed button diaphragm type)
Button diaphragm: 1½ in. External screw
for Regular / Oxygen service

Model No.: STH960 - I II III IV V VI VII VIII - Option I - Option II

Model No.: STH980 - I II III IV V VI VII VIII - Option I - Option II

Basic Model No.

	Measuring span	35 to 3500 kPa (0.35 to 35 kgf/cm ²)	STH960	Button diaphragm type: 1½ in. external screw
		0.7 to 42 MPa (7 to 420 kgf/cm ²)	STH980	

Selection I				Code	Fill fluid code	
I	Fill fluid	Flange type	Model No.	Fill fluid	1	2
		Button diaphragm type 1½ in. external screw	STH960	Regular type service (Silicone oil)	1	
				For oxygen service (Fluorine oil) *3	2	
			STH980	Regular type service (Silicone oil)	1	
				For oxygen service (Fluorine oil) *3	2	
II	Flange standard	No flange		N	✓	✓
III	Flange type & rating	1½ in. external screw button diaphragm		2	✓	✓
IV	Screw material	SUS304		7	✓	✓
V	Material of wetted parts	SUS316 (Diaphragm: SUS316L, others: SUS316)		2	✓	✓
		SUS316L (Diaphragm: SUS316L, others: SUS316L)		8	✓	✓
VI	Finish of gasket face	Standard (JIS Ra3.2 (12.5S))		J	✓	✓
VII	Length of extended parts	Flush diaphragm (for 1½ in. external screw)		00	✓	✓
VIII	Length of capillary tube	2 m		2	✓	✓
		3 m		3	✓	✓
		4 m		4	✓	✓
		5 m		5	✓	✓
	Length of capillary tube with olefin coating	2 m		B	✓	✓
		3 m		C	✓	✓
		4 m		H	✓	✓
		5 m		D	✓	✓

(Continued)

(Continued from previous page)

Model No.: STH960 - I II III IV V VI VII VIII - Option I - Option II

Model No.: STH980 - I II III IV V VI VII VIII - Option I - Option II

		Code	Fill fluid code	
		-	1	2
Options I	No options	X	✓	✓
	Built-in indicating smart meter (0 to 100% liner scales)	P	✓	✓
	Built-in indicating smart meter (engineering unit scales)	R	✓	✓
	SUS304 bolt and nuts material	W	✓	✓
	SUS630 bolt and nuts material	U	✓	✓
	Corrosion-resistant finish	A	✓	✓
	Corrosion-proof finish	B	✓	✓
	Corrosion-resistant finish, silver paint	D	✓	✓
	Oil free finish	K	✓	✓
	FM Explosionproof	3	✓	✓
	ATEX Flameproof	6	✓	✓
		-		
Options II	No option	XX	✓	✓
	Water free finish (with oil free finish)	A7	✓	✓
	NEPSI Flameproof	C1	✓	✓
	Custom calibration	C7	✓	✓
	FOUNDATION™ fieldbus *33	D6	✓	✓
	One elbow	E1	✓	✓
	Two elbows	E2	✓	✓
	Mounting bracket	E9	✓	✓
	PED (97/23/EC) conformity *34 *36	H1	✓	✓
	Material certificate	H2	✓	✓
	Max working pressure 20 MPa	H3	✓	✓
	Fieldbus communication stack BASIC class (used with option D6) *33	L1	✓	✓
	SI unit	U1	✓	✓

Note) *3 In case “for oxygen or chlorine (fluorine oil) service” is used, “oil free finish - code K” option must be selected.

*33 “FOUNDATION™ fieldbus - code D6” and “Fieldbus communication stack BASIC class - code L1” must be selected.

*34 “PED conformity” is not applicable for the combination with FM, CSA or NEPSI approvals.

*36 Applicable for model STH980 only.

ST3000 series 900 electric pressure transmitter

Model STH920 / STH940 / STH960 / STH980 (Remote-sealed 2 in. wafer diaphragm type)

2 in. wafer (Pancake)

Model No.: STH9X0 - I II III IV V VI VII VIII - Option I - Option II

Basic Model No.

	Measuring span	2.5 to 100 kPa (250 to 10,160 mmH ₂ O)	STH920	2 in. wafer diaphragm type ANSI 1500 equivalent
		35 to 3500 kPa (0.35 to 350 kgf/cm ²)	STH940	
		0.7 to 10 MPa (7 to 102 kgf/cm ²)	STH960	
		0.7 to 42 MPa (7 to 420 kgf/cm ²)	STH980	

Selection I				Code	Fill fluid code		
I	Fill fluid	Flange type	Model No.	Fill fluid	-	1	2
		2 in. wafer	STH920 / STH940 / STH960	Regular type service (Silicone oil)	1		
				For oxygen service (Fluorine oil) *3	2		
			STH980	Regular type service (Silicone oil)	1		
				For oxygen service (Fluorine oil) *3	2		
II	Flange standard	No flange			N	✓	✓
III	Flange type & rating	2 in. male screw button diaphragm			1	✓	✓
IV	Flange material	No flange			N	✓	✓
V	Material of wetted parts	SUS316 (Diaphragm: SUS316L, others: SUS316)			2	✓	✓
		SUS316L (Diaphragm:SUS316L, others: SUS316L)			8	✓	✓
VI	Finish of gasket face	Standard (JIS Ra3.2 (12.5S))			J	✓	✓
VII	Length of extended parts	Flush			00	✓	✓
VIII	Length of capillary tube	2 m			2	✓	✓
		3 m			3	✓	✓
		4 m			4	✓	✓
		5 m			5	✓	✓
		6 m			6	✓	✓
		7 m			7	✓	✓
		8 m			8	✓	✓
		9 m			9	✓	✓
		10 m			A	✓	✓
		Length of capillary tube with olefin coating	2 m			B	✓
	3 m			C	✓	✓	
	4 m			H	✓	✓	
	5 m			D	✓	✓	
	6 m			J	✓	✓	
	7 m			E	✓	✓	
	8 m			F	✓	✓	
	9 m			K	✓	✓	
	10 m			G	✓	✓	

(Continued)

(Continued from previous page)

Model No.: STH9X0 - I II III IV V VI VII VIII - **Option I - Option II**

		Code	Fill fluid code	
		-	1	2
Options I	No options	X	✓	✓
	Built-in indicating smart meter (0 to 100% liner scales)	P	✓	✓
	Built-in indicating smart meter (engineering unit scales)	R	✓	✓
	SUS630 bolt and nuts material	U	✓	✓
	Corrosion-resistant finish	A	✓	✓
	Corrosion-proof finish	B	✓	✓
	Corrosion-resistant finish, silver paint	D	✓	✓
	Oil free finish	K	✓	✓
	FM Explosionproof	3	✓	✓
	ATEX Flameproof	6	✓	✓
		-		
Options II	No option	XX	✓	✓
	Water free finish (with oil free finish)	A7	✓	✓
	NEPSI Flameproof	C1	✓	✓
	Custom calibration	C7	✓	✓
	FOUNDATION™ fieldbus *33	D6	✓	✓
	One elbow	E1	✓	✓
	Two elbows	E2	✓	✓
	Mounting bracket	E9	✓	✓
	PED (97/23/EC) conformity *34 *36	H1	✓	✓
	Material certificate	H2	✓	✓
	Max working pressure 20 MPa	H3	✓	✓
	Fieldbus communication stack BASIC class (used with option D6) *33	L1	✓	✓
	SI unit	U1	✓	✓

Note) *3 In case “for oxygen or chlorine (fluorine oil) service” is used, “oil free finish - code K” must be selected.

*33 “FOUNDATION™ fieldbus - code D6” and “Fieldbus communication stack BASIC class - code L1” must be selected.

*34 “PED conformity” is not applicable for the combination with FM, CSA or NEPSI approvals.

*36 Applicable for model STH980 only.

ST3000 series 900 electric pressure transmitter
Model STH940 / STH960 (Remote-sealed 2 in. wafer diaphragm type)
2 in. wafer (Pancake)
for High-temperature / Vacuum, high-temperature / High-vacuum service

Model No.: STH940 - I II III IV V VI VII VIII - Option I - Option II

Model No.: STH960 - I II III IV V VI VII VIII - Option I - Option II

Basic Model No.

Measuring span	35 to 3500 kPa (0.35 to 350 kgf/cm ²)	STH940	2 in. wafer diaphragm type ANSI 1500 equivalent
	0.7 to 10 MPa (7 to 102 kgf/cm ²)	STH960	

Selection I				Code	Fill fluid code		
I	Fill Fluid	Flange Type	Model No.	Fill fluid	-	4	7
		2 in. wafer	STH940	For high-temperature vacuum service (Silicone oil)	4		
			STH960	For high-temperature high-vacuum service (Silicone oil)	7		
II	Flange standard	No flange			N	✓	✓
III	Flange type & Rating	2 in. wafer type (ANSI 1500 equivalent)			1	✓	✓
IV	Flange material	No flange			N	✓	✓
V	Material of wetted Parts	SUS316L (Diaphragm:SUS316L, others: SUS316L)			8	✓	✓
VI	Finish of gasket face	Standard (JIS Ra3.2 (12.5S))			J	✓	✓
VII	Length of extended parts	Flush			00	✓	✓
VIII	Length of capillary tube	2 m			2	✓	✓
		3 m			3	✓	✓
		4 m			4	✓	✓
		5 m			5	✓	✓
		6 m			6	✓	✓
		7 m			7	✓	✓
		8 m			8	✓	✓
		9 m			9	✓	✓
		10 m			A	✓	✓

Options I	No options	X	✓	✓
	Built-in indicating smart meter (0 to 100% liner scales)	P	✓	✓
	Built-in indicating smart meter (engineering unit scales)	R	✓	✓
	SUS630 Bolt and nuts material	U	✓	✓
	Corrosion-resistant finish	A	✓	✓
	Corrosion-proof finish	B	✓	✓
	Corrosion-resistant finish, silver paint	D	✓	✓
	Oil free finish	K	✓	✓
	FM Explosion	3	✓	✓
	ATEX Flameproof	6	✓	✓

Options II	No option	XX	✓	✓
	Water free finish (with oil free finish)	A7	✓	✓
	NEPSI Flameproof	C1	✓	✓
	Custom calibration	C7	✓	✓
	FOUNDATION™ fieldbus *33	D6	✓	✓
	One elbow	E1	✓	✓
	Two elbows	E2	✓	✓
	Mounting bracket	E9	✓	✓
	Material certificate	H2	✓	✓
	Fieldbus communication stack BASIC class (used with option D6) *33	L1	✓	✓
	SI unit	U1	✓	✓

Note) *33 “FOUNDATION™ fieldbus - code D6” and “Fieldbus communication stack BASIC class - code L1” must be selected.

DIMENSIONS

Model STH920 / STH940 / STH960

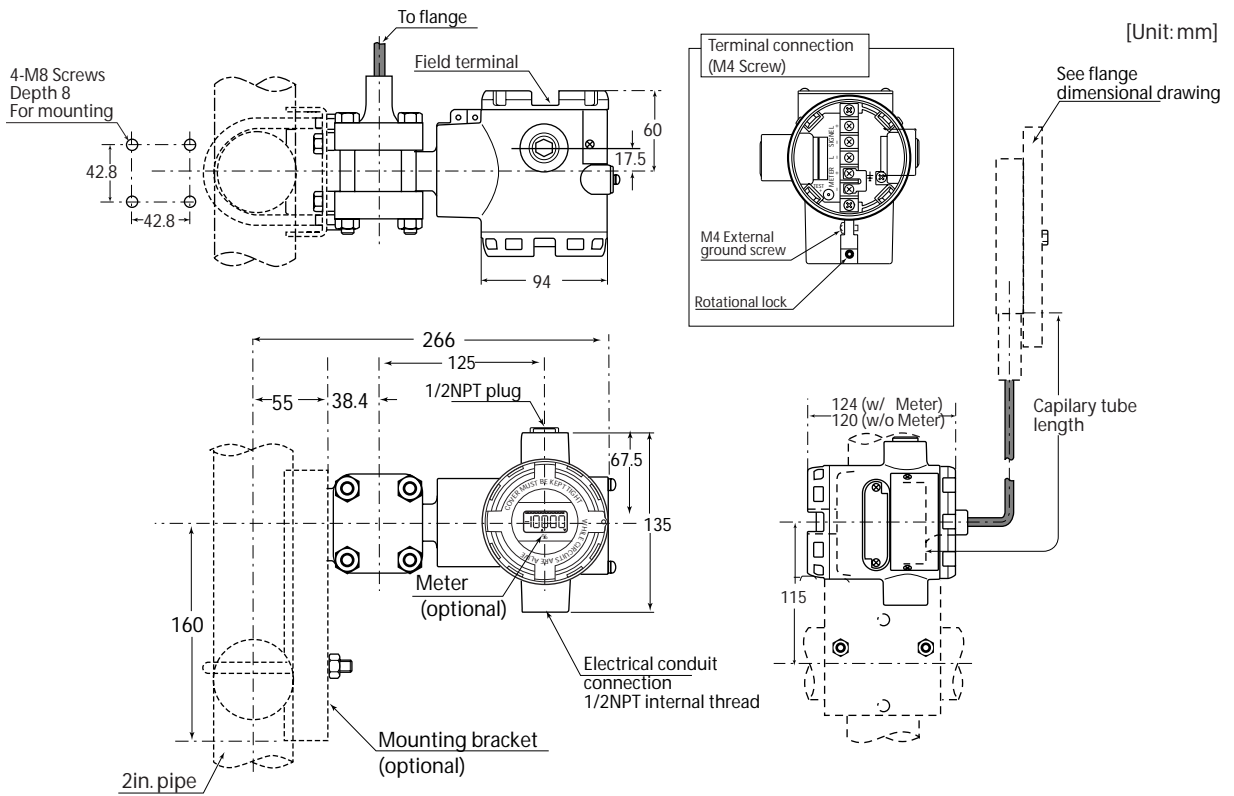

Model STH980

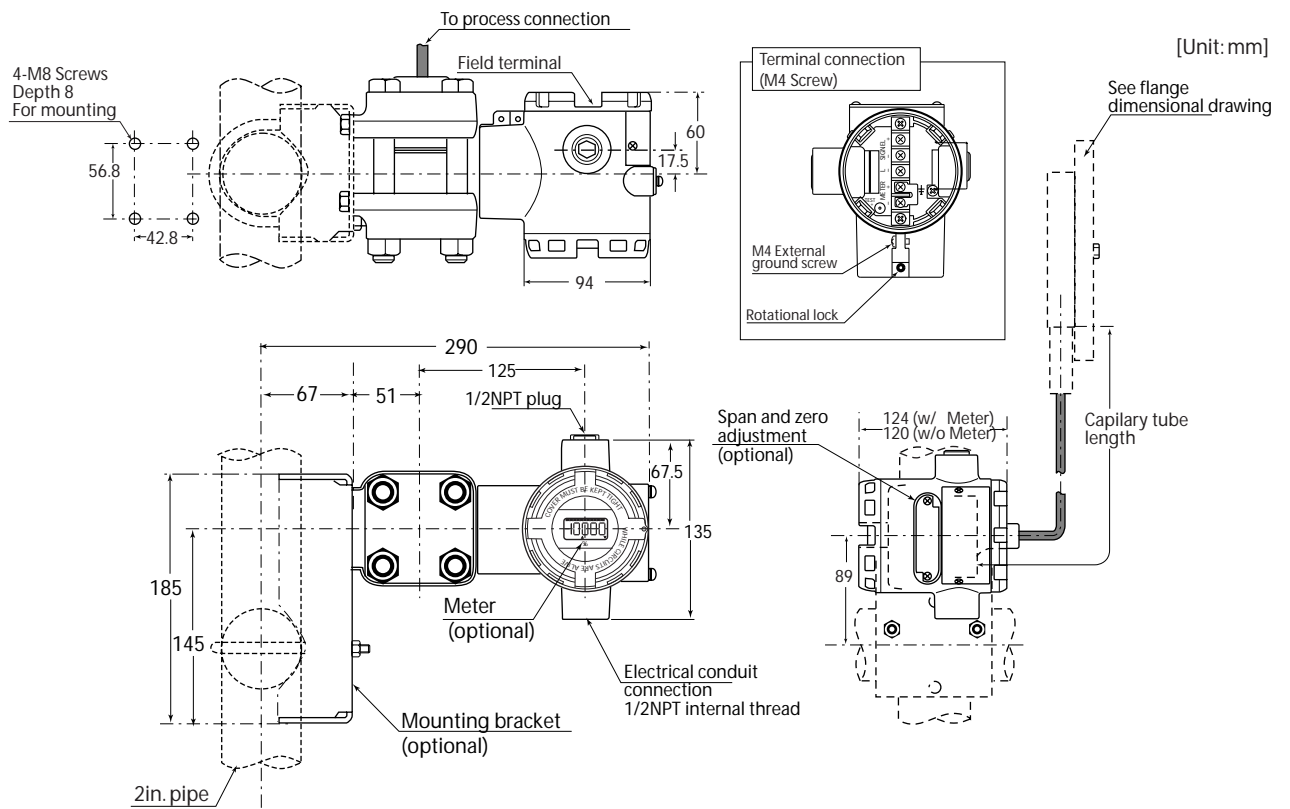

- Note) 1. To prevent vibration, you are recommended to fasten the capillary tube mid-length.
 2. Select a gasket that will not contact the diaphragm after it is tightened.

Model STH920 / STH940 / STH960

Table of flash diaphragm flange dimensions

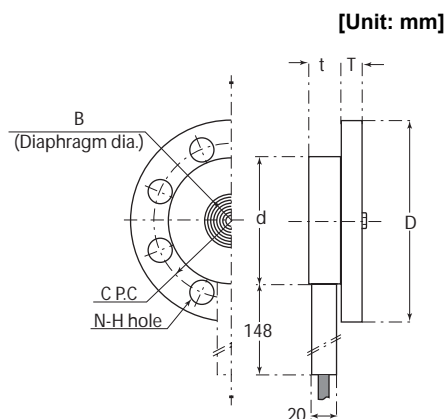

[Unit: mm]

Rating	Flange rating	D	T	C	N	H	d	t	B
1.5 in./ 40 mm	JIS 10K - 40 mm	140	16	105	4	19	81	25 ^{*i}	43
	JIS 20K - 40 mm	140	18	105	4	19			
	JIS 30K - 40 mm	160	22	120	4	23			
	ANSI 150 - 1.5 in.	127	18	98.6	4	16			
	ANSI 300 - 1.5 in.	155	21	114.3	4	22			
	ANSI 600 - 1.5 in.	155	22.5	114.3	4	22			
	JPI 150 - 1.5 in.	127	18	98.6	4	16			
	JPI 300 - 1.5 in.	155	21	114.3	4	22			
2 in./ 50 mm	JIS 10K - 50 mm	155	16	120	4	19	99	62 ^{*ii}	
	JIS 20K - 50 mm	155	18	120	8	19			
	JIS 30K - 50 mm	165	22	130	8	19			
	ANSI 150 - 2 in.	152	19.5	120.6	4	19			
	ANSI 300 - 2 in.	165	22.5	127	8	19			
	ANSI 600 - 2 in.	165	25.5	127	8	19			
	JPI 150 - 2 in.	152	19.5	120.6	4	19			
	JPI 300 - 2 in.	165	22.5	127	8	19			
3 in./ 80 mm	JIS 10K - 80 mm	185	18	150	8	19	129.5	25	95
	JIS 20K - 80 mm	200	22	160	8	23			
	JIS 30K - 80 mm	210	28	170	8	23			
	ANSI 150 - 3 in.	190	24	152.4	4	19			
	ANSI 300 - 3 in.	210	28.5	168.1	8	22			
	ANSI 600 - 3 in.	210	32	168.1	8	22			
	JPI 150 - 3 in.	190	24	152.4	4	19			
	JPI 300 - 3 in.	210	28.5	168.1	8	22			
JPI 600 - 3 in.	210	32	168.1	8	22				

- i. Wetted parts material is Hastelloy C and fill fluid is for regular, high-temperature, oxygen, or chlorine service: t=26.7
- ii. Wetted parts material is Hastelloy C and fill fluid is for regular, high-temperature, oxygen, or chlorine service: B=43

Table of extended diaphragm flange dimensions

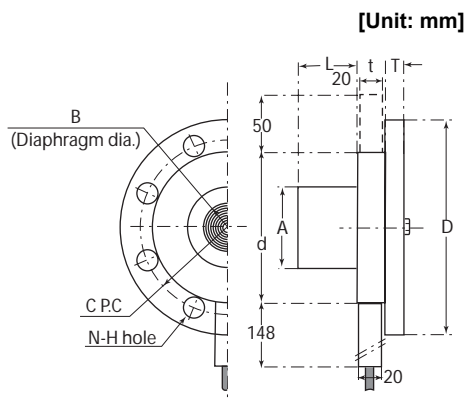

[Unit: mm]

Rating	Flange rating	D	T	C	N	H	d	A	t	B	L
2 in./ 50 mm	JIS 10K - 50 mm	155	16	120	4	19	99	47±1	25	43	50
	JIS 20K - 50 mm	155	18	120	8	19					100
	JIS 30K - 50 mm	165	22	130	8	19					150
	ANSI 150 - 2 in.	152	19.5	120.6	4	19					200
	ANSI 300 - 2 in.	165	22.5	127	8	19					250
	ANSI 600 - 2 in.	165	25.5	127	8	19					300
	JPI 150 - 2 in.	152	19.5	120.6	4	19					
	JPI 300 - 2 in.	165	22.5	127	8	19					
	JPI 600 - 2 in.	165	25.5	127	8	19					
3 in./ 80 mm	JIS 10K - 80 mm	185	18	150	8	19	129.5	69±1	25	62 ^{*i}	
	JIS 20K - 80 mm	200	22	160	8	23					
	JIS 30K - 80 mm	210	28	170	8	23					
	ANSI 150 - 3 in.	190	24	152.4	4	19					
	ANSI 300 - 3 in.	210	28.5	168.1	8	22					
	ANSI 600 - 3 in.	210	32	168.1	8	22					
	JPI 150 - 3 in.	190	24	152.4	4	19					
	JPI 300 - 3 in.	210	28.5	168.1	8	22					
JPI 600 - 3 in.	210	32	168.1	8	22						
4 in./ 100 mm	JIS 10K - 100 mm	210	18	175	8	19	157	95±1	23	90.4	
	JIS 20K - 100 mm	225	24	185	8	23					
	JIS 30K - 100 mm	240	32	195	8	25					
	ANSI 150 - 4 in.	229	24	190.5	8	19					
	ANSI 300 - 4 in.	254	32	200.2	8	22					
	JPI 150 - 4 in.	229	24	190.5	8	19					
JPI 300 - 4 in.	254	32	200.2	8	22						

- i. Wetted parts material is Hastelloy C and fill fluid is for regular, high-temperature, oxygen, or chlorine service: B=43

2 in wafer bottom diaphragm.

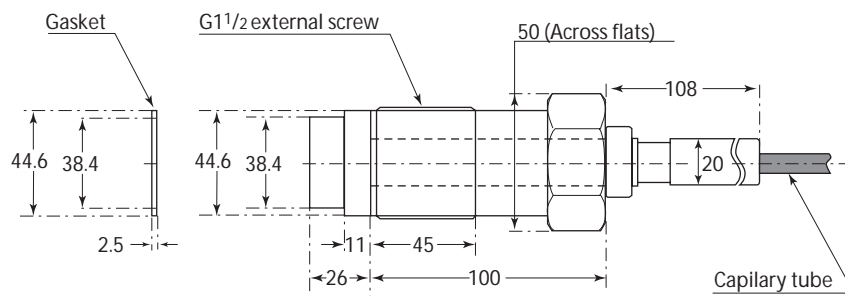
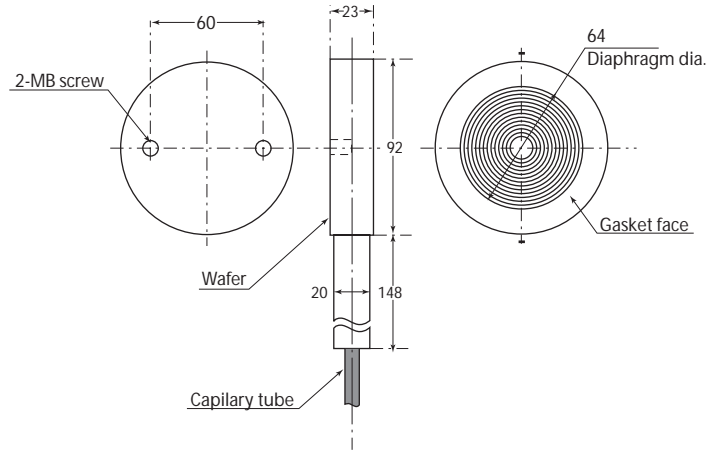

azbil

Yamatake Corporation
Advanced Automation Company

1-1-12 Kawana, Fujisawa
Kanagawa 251-8522 Japan

URL:<http://www.azbil.com>