

ST3000 Series 900 Smart Transmitter

Pressure Transmitters with FOUNDATION™ fieldbus Model STG940/STG960/STG981

OVERVIEW

The ST3000 Series 900 with FOUNDATION™ fieldbus is an accurate, stable, and reliable pressure / differential pressure transmitter, which fully complies with the 31.25 kbps voltage mode FOUNDATION™ fieldbus. Its built-in AI function blocks provide process variables to devices on the Fieldbus and its PID control function block enables process control in the field.

Since the ST3000 Series 900 is FOUNDATION™ registered, it can operate seamlessly with other registered field devices as well as host systems in a wide range of control applications.

FEATURES

Excellent stability and high performance

- Long-term stability is proven in 500,000 installations worldwide.
- Unique characterization and composite semiconductor sensors realize excellent temperature and static pressure characteristics.

Wide measuring range (rangeability)

A wide measuring range is available from a single model. This feature is highly effective in taking measurements over a wide range and reducing the need for reserve units

- The measuring range of the model STG940, for example, is 35 to 3500 kPa (rangeability = 1 : 100).

A diverse lineup

- A wide range of models is available to meet user needs for low, standard, and high pressures.
- A wide variety of corrosion-resistant materials for wetted parts is also available.

FOUNDATION™ is a registered trademark of the Fieldbus Foundation.



APPLICATION

Petroleum / Petrochemical / Chemical

For measuring pressures and liquid levels in pipes and tanks.

Electric power / City gas / Other utilities

For measurement applications that require high degrees of stability and accuracy.

Pulp and paper

For lines that need transmitters resistant to chemical liquids, corrosive fluids and the like

Iron and steel / Nonferrous metal / Ceramics

For lines that require stable measurement under strictly controlled (temperature, humidity, etc.) conditions.

Machinery / Shipbuilding

For lines that require stable measurement under strictly controlled (temperature, humidity, etc.) conditions.

FUNCTIONAL SPECIFICATIONS

Type of protection

JIS C0920 watertight: NEMA3 and 4X
 JIS F8001 class 2 watertight: IEC IP67

FM Explosionproof approval

Explosionproof for Class I (Gas, steam), Division 1, Group A, B, C, D

Dust-ignition for Class II (Inflammable dust), Division 1, Group E, F, G

Suitable for Class III (inflammable fiber), Division 1

Nonincendive for Class I, Division 2, Group A, B, C, D

ATEX Flameproof approval

Ⓔ II 2 GD EEx d IIC T6 at $-20 \leq T_{amb} \leq +60^{\circ}\text{C}$

NEPSI Flameproof approval

Ex d IIC T6 (with NEPSI Dust Ignition DIP DT T13)

EMC Conformity

89/336/EEC, 92/31/EEC, 93/68/EEC Electromagnetic Compatibility (EMC) Directive

PED Conformity (97/23/EC)

Comply with Module H (with “H1” option), or SEP (Sound Engineering Practice) for models of which maximum working pressure is 200 bar or lower.

Lowest temperature for Module H

Bolt/nut material SNB7: -10°C
 SUS630: -6°C

Measuring span / Setting range / Working pressure range

	Measuring span	Setting range	Working pressure range	Overload resistant value
STG 940	35 to 3500 kPa {0.35 to 35 kgf/cm ² }	-100 to 3500 kPa {-1 to 35 kgf/cm ² }	2.0 kPa abs. to 3500 kPa {15 mmHg abs. to 35 kgf/cm ² } ^{*i} See Figure 1	5250 kPa {52.5 kgf/cm ² }
STG 960	0.7 to 14 MPa {7 to 140 kgf/cm ² }	-0.1 to 14 MPa {-1 to 140 kgf/cm ² }	2.0kPa abs. to 14 MPa {15mmHg abs. to 140kgf/cm ² } ^{*ii} See Figure 1	21 MPa {210 kgf/cm ² }
STG 981	0.7 to 4 2MPa {7 to 420 kgf/cm ² }	-0.1 to 42 MPa {-1 to 420 kgf/cm ² }	2.0kPa abs. to 42 MPa {15mmHg abs. to 420kgf/cm ² } ^{*iii} See Figure 1	63 MPa {630 kgf/cm ² }

Note *i. With PVC wetted parts, the maximum working pressure is 1.5 MPa {15 kgf/cm²}.
 Note *ii. With SUS304 bolts and nuts, the maximum working pressure is 7 MPa {70 kgf/cm²}.
 Note *iii. With SUS304 bolts and nuts, the maximum working pressure is 23 MPa {230 kgf/cm²}.

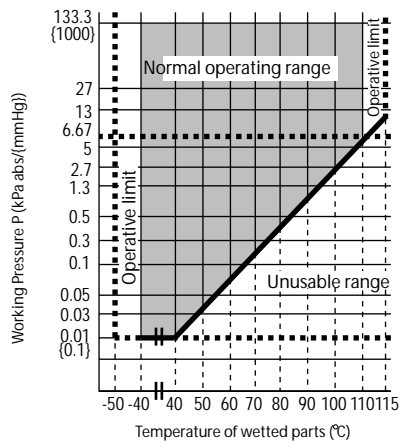

Figure 1 Working pressure and temperature of wetted parts section (for general purpose models)

Supply voltage and load resistance

9 to 32 V DC

Ambient temperature limits

Normal operating range

-40 to 85°C for general purpose models
 -10 to 75°C for oxygen and chlorine models
 -20 to 70°C for models with digital indicators

Operative limits

-50 to 93°C for general purpose models
 -40 to 80°C for oxygen and chlorine models
 -30 to 80°C for models with digital indicators

Transportation and storage conditions

-50 to 85°C

Temperature ranges of wetted parts

Normal operating range

-40 to 110°C for general purpose models
 -10 to 75°C for oxygen and chlorine models

Operative limits

-50 to 115°C for general purpose models
 -40 to 80°C for oxygen and chlorine models

Ambient humidity limits

5 to 100% RH

Stability against supply voltage change

$\pm 0.005\%$ FS/V

Lightning protection

Peak value of voltage surge: 12 kV

Peak value of current surge: 1000 A

Optional specifications

Built-in indicating meter

The digital LCD indicator (optional) indicates engineering units and can be set freely between -19999 and 19999 (4.5 digits).

Bolts and nuts materials (for fastening meter body cover)

Carbon steel (SNB7), SUS304, SUS630

(Pressure rating 7000 kPa {70 kgf/cm²} or Flange rating)

Baked acrylic paint.

Corrosion-resistant finish

Corrosion-resistant finish

Corrosion-resistant paint (Baked acrylic paint), fungus-proof finish.

Corrosion-proof finish

Corrosion-proof paint (Baked epoxy paint), fungus-proof finish.

Corrosion-resistant finish (silver paint)

Transmitter case is coated with silver paint in addition to the above corrosion-resistant finish.

Oil free finish

The transmitter is shipped with oil-free wetted parts.

Long vent / drain plugs

A longer (58 mm) drain than the standard (24 mm) can be used for maintenance, process, and safety reasons.

Elbow

This is an adaptor for changing the electrical conduit connection port from the horizontal to the vertical direction, if required by wiring conditions in the field. One or two elbows may be used as needed.

Conformance to SI units

We deliver transmitters set to any SI units as specified.

PHYSICAL SPECIFICATIONS**Materials****Fill fluid**

Silicone oil for general purpose and high-temperature vacuum models

Fluorine oil for oxygen and chlorine models

Center body

SUS316

Transmitter case

Aluminum alloy

Meter body cover

SCS14A (Equivalent to SUS316) or SUSF316, PVC

For Wetted parts**Adapter flange (option)**

SCS14A (Equivalent to SUS316), PVC

Center body

SUS316 (Diaphragm SUS316L)

Hastelloy C, Tantalum, SUS316L

Vents and plugs

SUS316, PVC

Gaskets

FEP, SFVC2A for model STG981

Finish

Baked acrylic paint

Housing light beige (Munsell 4Y7.2/1.3)

Cap dark beige (Munsell 10YR4.7/0.5)

Weight

Approx. 4.4 kg

INSTALLATION**Electrical connection**

1/2NPT internal thread

Grounding

Resistance 100 Ω max.

Mounting

Can be installed on a 2 inch horizontal or vertical pipe (can be directly mounted on a process pipe)

Process connection

Rc1/2, 1/2NPT internal thread and Rc1/4, 1/4NPT internal thread

PERFORMANCE SPECIFICATIONS

Accuracy

Shown for each item is the percentage ratio for χ (kPa), which is the greatest value of either XD_SCALE_EU_100, XD_SCALE_EU_0, or the span.

Model STG940

(Material of wetted parts: Diaphragm; SUS316L, Others; SUS316)

Accuracy (*3)		$\pm 0.075\%$	(For $\chi \geq 1750kPa$ {17.5 kgf/cm ² })
		$\pm 0.1\%$	(1750kPa{17.5kgf/cm ² }> $\chi \geq 5.0kPa$ {500 mmH ₂ O})
		$\pm\left(0.025 + 0.075 \times \frac{140}{\chi}\right)\%$	(For $\chi < 140kPa$ {1.4 kgf/cm ² })
Temperature characteristics (Shift from the set range) Change of 55°C (*3)	Zero shift:	$\pm\left(0.25 + 0.3 \times \frac{350}{\chi}\right)\%$	
	Combined shift: (including zero and span shifts)	$\pm 0.8\%$	(For $\chi \geq 350kPa$ {3.5 kgf/cm ² })
		$\pm\left(0.35 + 0.45 \times \frac{350}{\chi}\right)\%$	(For $\chi < 350kPa$ {3.5 kgf/cm ² })

Model STG960

(Material of wetted parts: Diaphragm; SUS316L, Others; SUS316)

Accuracy (*3)		$\pm 0.15\%$	(For $\chi \geq 2.1MPa$ {21 kgf/cm ² })
		$\pm\left(0.05 + 0.1 \times \frac{3.5}{\chi}\right)\%$	(For $\chi < 2.1MPa$ {21 kgf/cm ² })
Temperature characteristics (Shift from the set range) Change of 55°C (*3)	Zero shift:	$\pm\left(0.25 + 0.3 \times \frac{3.5}{\chi}\right)\%$	
	Combined shift: (including zero and span shifts)	$\pm 0.8\%$	(For $\chi \geq 3.5MPa$ {35 kgf/cm ² })
		$\pm\left(0.35 + 0.45 \times \frac{3.5}{\chi}\right)\%$	(For $\chi < 3.5MPa$ {35 kgf/cm ² })

Model STG981

(Material of wetted parts: Diaphragm; SUS316L, Others; SUS316)

Accuracy (*3)		$\pm 0.15\%$	(For $\chi \geq 7MPa$ {70 kgf/cm ² })
		$\pm\left(0.05 + 0.1 \times \frac{7}{\chi}\right)\%$	(For $\chi < 7MPa$ {70 kgf/cm ² })
Temperature characteristics (Shift from the set range) Change of 55°C (*3)	Zero shift:	$\pm\left(0.25 + 0.3 \times \frac{7}{\chi}\right)\%$	
	Combined shift: (including zero and span shifts)	$\pm 0.8\%$	(For $\chi \geq 7MPa$ {70 kgf/cm ² })
		$\pm\left(0.35 + 0.45 \times \frac{7}{\chi}\right)\%$	(For $\chi < 7MPa$ {70 kgf/cm ² })

Note (*1): XD_SCALE_EU_100 denotes the upper limit of the calibration range.

(*2): XD_SCALE_EU_0 denotes the lower limit of the calibration range.

(*3): Within a range of XD_SCALE_EU_100 ≥ 0 and XD_SCALE_EU_0 ≥ 0 .

Model STG940

(Material of wetted parts: Diaphragm; Hastelloy C, Tantalum, SUS316L Others; Hastelloy C, Tantalum, SUS316L)

Accuracy (*3)		$\pm 0.2\%$	(For $\chi \geq 140kPa$ { 1.4 kgf/cm ² })
		$\pm\left(0.05 + 0.15 \times \frac{140}{\chi}\right) \%$	(For $\chi < 140kPa$ { 1.4 kgf/cm ² })
Temperature characteristics (Shift from the set range) Change of 30°C (*3) (Range from -5 to 55°C)	Zero shift:	$\pm\left(0.15 + 0.45 \times \frac{350}{\chi}\right) \%$	
	Combined shift: (including zero and span shifts)	$\pm 0.85\%$	(For $\chi \geq 350kPa$ { 3.5 kgf/cm ² })
		$\pm\left(0.35 + 0.5 \times \frac{350}{\chi}\right) \%$	(For $\chi < 350kPa$ { 3.5 kgf/cm ² })

Model STG960

(Material of wetted parts: Diaphragm; Hastelloy C, Tantalum, SUS316L Others; Hastelloy C, Tantalum, SUS316L)

Accuracy (*3)		$\pm 0.2\%$	(For $\chi \geq 2.1MPa$ { 21 kgf/cm ² })
		$\pm\left(0.05 + 0.15 \times \frac{2.1}{\chi}\right) \%$	(For $\chi < 2.1MPa$ { 21 kgf/cm ² })
Temperature characteristics (Shift from the set range) Change of 30°C (*3) (Range from -5 to 55°C)	Zero shift:	$\pm\left(0.15 + 0.45 \times \frac{3.5}{\chi}\right) \%$	
	Combined shift: (including zero and span shifts)	$\pm 0.85\%$	(For $\chi \geq 3.5MPa$ { 35 kgf/cm ² })
		$\pm\left(0.35 + 0.5 \times \frac{3.5}{\chi}\right) \%$	(For $\chi < 3.5MPa$ { 35 kgf/cm ² })

Note) (*3): Within a range of $XD_SCALE_EU_100 \geq 0$ and $XD_SCALE_EU_0 \geq 0$.

FIELDBUS SPECIFICATIONS**Block supported by the S900**

Name of block	Number of block	Description	Max. execution time msec.
Resource block	1	The Resource Block (RB) maintains overall resources of the S900.	-
Transducer block	1	The Transducer Block (XB) interfaces with the sensing element of the S900, converts the measured value into specified engineering unit, and sends it to the AI Function Block.	-
AI Function Block	2	The AI Function Block (AI FB) accepts an analog input signal from the XB, scales it, detects alarm conditions, and provides it in a uniform format on the Fieldbus network.	75
Diagnostics Block	1	The Diagnostics Block (DB) is Yamatake proprietary block which provides the result of self-diagnostics of the S900.	-
PID Function Block	1	The PID Function Block (PID FB) accepts a process variable (PV) from an AI Function Block on the Fieldbus network, calculates the valve position using the PID algorithm, and sends a new valve output signal to the AO Function Block.	125

VCR structure

The S900 has 16 VCRs (Virtual Communication Relationships), of which the first one is dedicated to the SMIB/NMIB as defined by Foundation Fieldbus specifications. The rest of the VCRs are fully configurable. Their default configurations are shown below:

VCR No.	Configuration	VCR No.	Configuration
1	QUB (Server) for NIMIB/SMIB	9	QUU (Source)
2	BNU (Subscriber)	10	QUU (Source)
3	BNU (Subscriber)	11	QUU (Source)
4	BNU (Subscriber)	12	QUB (Server)
5	BNU (Subscriber)	13	QUB (Server)
6	BNU (Publisher)	14	QUB (Server)
7	BNU (Publisher)	15	QUB (Server)
8	QUU (Source)	16	QUB (Server)

Network parameters

The following table lists the key parameter values that affect the interoperability of the Fieldbus devices. The LAS must be configured to satisfy these parameters. If other devices on the same Fieldbus network require a greater number for them, the greater number must be used. This however will degrade network performance.

Symbol	Parameter name	Range of value
V (ST)	Slot Time	4 to 100
V (MID)	Minimum Interframe Gap	10 to $(V (MRD) - 1) \times V (ST)$, less than 120 inclusive.
V (MRD)	Maximum Response Delay	$V (MRD) \times V (ST)$ shall be greater than 20 and $V (MRD)$ shall be less than 11, inclusive.
T1	SM step timer	96000 (3 seconds)
T2	SM set address sequence timer	1920000 (60 seconds)
T3	SM set address wait timer	480000 (15 seconds)

Note) • An LAS requires parameters other than those listed here for operation. Please refer to the user's manual that is provided with your LAS device.
• The T3 must be set between 15 seconds and 60 seconds.

MODEL SELECTION

ST3000 series 900 electric pressure transmitter

Model STG940 (Low gauge pressure)

Model No.: STG940 - I II III - 00000 - Option I - Option II

Basic Model No.

	Measuring span	35 to 3500 kPa (0.35 to 35 kgf/cm ²)	STG940
--	----------------	--	--------

Selection I						Code	Material code									
I	Material	Meter body cover	Adapter flange	Vent / drain plugs	Center body		E	F	H	U	M	P	8	9		
		SCS14A*1	SCS14A*1	SUS316	Diaphragm:SUS316L Others: SUS316	E										
		SCS14A*1	SCS14A*1	SUS316	Diaphragm: Hastelloy C Others: Hastelloy C	F										
		SCS14A*1	SCS14A*1	SUS316	Diaphragm: Tantalum Others: Tantalum	H										
		SCS14A*1	SCS14A*1	SUS316	Diaphragm:SUS316L Others: SUS316L	U										
		PVC	PVC	PVC	Diaphragm: Hastelloy C Others: Hastelloy C *8	M										
		PVC	PVC	PVC	Diaphragm: Tantalum Others: Tantalum *8	P										
II	Fill Fluid	Regular type (Silicone oil)				1	✓	✓	✓	✓	✓	✓	✓	✓		
		For oxygen service (Fluorine oil) *3				2	✓	✓	✓	✓	✓	✓	✓	✓		
		For chlorine service (Fluorine oil) *3				5			✓			✓				
III	Process connection	Front connection	Rc1/2 with adapter flange			L	✓	✓						✓	✓	
			1/2NPT internal thread with adapter flange			G	✓	✓							✓	✓
			Rc1/4 with adapter flange			D	✓	✓							✓	✓
			1/4NPT internal thread with adapter flange			A	✓	✓							✓	✓
			1/4NPT internal thread on head			B	✓	✓							✓	✓
			Rc1/2 with adapter flange *7			Q			✓	✓	✓	✓	✓			
			1/2NPT internal thread with adapter flange *7			R			✓	✓	✓	✓	✓			
	Top or bottom connection	Rc1/4 with adapter flange *7			S			✓	✓							
		1/4NPT internal thread with adapter flange *7			T			✓	✓							
		1/4NPT internal thread on head *7			U			✓	✓							
					-											
					00000											
					-											
					-											
Options I	No options					X	✓	✓	✓	✓	✓	✓	✓	✓		
	Built-in indicating smart meter (0 to 100% liner scales)					P	✓	✓	✓	✓	✓	✓	✓	✓		
	Built-in indicating smart meter (engineering unit scales)					R	✓	✓	✓	✓	✓	✓	✓	✓		
	SUS304 bolt and nuts material					W	✓	✓	✓	✓	✓	✓	✓	✓		
	SUS630 bolt and nuts material					U	✓	✓	✓	✓	✓	✓	✓	✓		
	Corrosion-resistant finish					A	✓	✓	✓	✓	✓	✓	✓	✓		
	Corrosion-proof finish					B	✓	✓	✓	✓	✓	✓	✓	✓		
	Corrosion-resistant finish, silver paint					D	✓	✓	✓	✓	✓	✓	✓	✓		
	Oil free finish					K	✓	✓	✓	✓	✓	✓	✓	✓		
	Long vent / drain plugs					J	✓	✓	✓	✓	✓	✓	✓	✓		
	FM Explosionproof					3	✓	✓	✓	✓	✓	✓	✓	✓		
ATEX Flameproof					6	✓	✓	✓	✓	✓	✓	✓	✓			
					-											
Options II	No option					XX	✓	✓	✓	✓	✓	✓	✓	✓		
	Water free finish (with oil free finish)					A7	✓	✓	✓	✓	✓	✓	✓	✓		
	NEPSI Flameproof					C1	✓	✓	✓	✓	✓	✓	✓	✓		
	Custom calibration					C7	✓	✓	✓	✓	✓	✓	✓	✓		
	FOUNDATION™ fieldbus *33					D6	✓	✓	✓	✓	✓	✓	✓	✓		
	One elbow					E1	✓	✓	✓	✓	✓	✓	✓	✓		
	Two elbows					E2	✓	✓	✓	✓	✓	✓	✓	✓		
	Mounting bracket					E9	✓	✓	✓	✓	✓	✓	✓	✓		
	Side vent / drain top					F1	✓	✓					✓	✓		
	Side vent / drain bottom					F2	✓	✓					✓	✓		
	Material certificate					H2	✓	✓	✓	✓	✓	✓	✓	✓		
	Fieldbus communication stack BASIC class (used with option D6) *33					L1	✓	✓	✓	✓	✓	✓	✓	✓		
	SI unit					U1	✓	✓	✓	✓	✓	✓	✓	✓		

Note) *1 SCS14A (equivalent SUS316) or SUSF316

*3 In case "for oxygen or chlorine (fluorine oil) service" is used, "oil free finish - code K" must be selected.

*7 Applicable for wetted parts of center body material; Tantalum, SUS316L

*8 SUS304 bolts and nuts material (-W) must be selected when PVC meterbody cover is selected (-M or -P). The max. working pressure is 1.5 MPa.

*33 "FOUNDATION™ fieldbus - code D6" and "Fieldbus communication stack BASIC class - code L1" must be selected.

ST3000 series 900 electric pressure transmitter

Model STG960 (Medium gauge pressure)

Model No.: STG960 - I II III - 00000 - Option I - Option II

Basic model No.

	Measuring span	0.7 to 14 MPa (7 to 140 kgf/cm ²)	STG960
--	----------------	---	--------

Selection I					Code	Material code		
I	Material	Meter body cover	Adapter flange	Vent / drain plugs	Wetted parts of center body	E	F	U
		SCS14A*1	SCS14A*1	SUS316	Diaphragm:SUS316L Others: SUS316	E		
		SCS14A*1	SCS14A*1	SUS316	Diaphragm: Hastelloy C Others: Hastelloy C	F		
		SCS14A*1	SCS14A*1	SUS316	Diaphragm: Tantalum Others: Tantalum	H		
		SCS14A*1	SCS14A*1	SUS316	Diaphragm:SUS316L Others: SUS316L	U		
II	Fill fluid	Regular type (Silicone oil)			1	✓	✓	✓
		For oxygen service (Fluorine oil) *3			2	✓	✓	✓
		For chlorine service (Fluorine oil) *3			5			✓
III	Process connection	Front connection	Rc1/2 with adapter flange		L	✓	✓	
			1/2NPT internal thread with adapter flange		G	✓	✓	
			Rc1/4 with adapter flange		D	✓	✓	
			1/4NPT internal thread with adapter flange		A	✓	✓	
			1/4NPT internal thread on head		B	✓	✓	
			Rc1/2 with adapter flange *7		Q			✓
	Top or bottom connection		1/2NPT internal thread with adapter flange *7		R			✓
			Rc1/4 with adapter flange *7		S			✓
			1/4NPT internal thread with adapter flange *7		T			✓
			1/4NPT internal thread on head		U			✓
					-			
					00000			
Options I					-			
No options					X	✓	✓	✓
Built-in indicating smart meter (0 to 100% liner scales)					P	✓	✓	✓
Built-in indicating smart meter (engineering unit scales)					R	✓	✓	✓
SUS304 bolt and nuts material *11					W	✓	✓	✓
SUS630 bolt and nuts material					U	✓	✓	✓
Corrosion-resistant finish					A	✓	✓	✓
Corrosion-proof finish					B	✓	✓	✓
Corrosion-resistant finish, silver paint					D	✓	✓	✓
Oil free finish					K	✓	✓	✓
Long vent / drain plugs					J	✓	✓	✓
FM Explosionproof					3	✓	✓	✓
ATEX Flameproof					6	✓	✓	✓
					-			
Options II					XX	✓	✓	✓
No option					XX	✓	✓	✓
Water free finish (with oil free finish)					A7	✓	✓	✓
NEPSI Flameproof					C1	✓	✓	✓
Custom calibration					C7	✓	✓	✓
FOUNDATION™ fieldbus *33					D6	✓	✓	✓
One elbow					E1	✓	✓	✓
Two elbows					E2	✓	✓	✓
Mounting bracket					E9	✓	✓	✓
Side vent / drain top					F1	✓	✓	
Side vent / drain bottom					F2	✓	✓	
Material certificate					H2	✓	✓	✓
Fieldbus communication stack BASIC class (used with option D6) *33					L1	✓	✓	✓
SI unit					U1	✓	✓	✓

Note) *1 SCS14A (equivalent SUS316) or SUSF316
 *3 In case "for oxygen or chlorine (fluorine oil) service" is used, "oil free finish - code K" must be selected.
 *7 Applicable for wetted parts of center body material; Tantalum, SUS316L
 *11 When SUS304 bolt/nut is selected, max. working pressure rating is 7 MPa (70 kgf/cm²)
 *33 "FOUNDATION™ fieldbus - code D6" and "fieldbus communication stack BASIC class - code L1" must be selected.

**ST3000 series 900 electric pressure transmitter
Model STG981 (High gauge pressure)**

Model No.: STG981 - I II III - 00000 - Option I - Option II

Basic model No.

Measuring span	0.7 to 42 MPa (7 to 420 kgf/cm ²)	STG981
----------------	---	--------

Selection I			Code	Material code			
I	Material	Meter body cover	Vent / drain plugs	Wetted parts of center body	E	F	
		SCS14A*1	SUS316	Diaphragm:SUS316L Others: SUS316			E
		SCS14A*1	SUS316	Diaphragm: Hastelloy C Others: Hastelloy C			F
II	Fill fluid	Regular type (Silicone oil)		1	✓	✓	
		For oxygen service (Fluorine oil) *3		2	✓	✓	
III	Process connection	Top or bottom connection	Rc1/4	S			
			1/4NPT internal thread	T	✓	✓	
			-				
			00000				
Options I			No options	X	✓	✓	
			Built-in indicating smart meter (0 to 100% liner scales)	P	✓	✓	
			Built-in indicating smart meter (engineering unit scales)	R	✓	✓	
			SUS304 bolt and nuts material *12	W	✓	✓	
			SUS630 bolt and nuts material	U	✓	✓	
			Corrosion-resistant finish	A	✓	✓	
			Corrosion-proof finish	B	✓	✓	
			Corrosion-resistant finish, silver paint	D	✓	✓	
			Oil free finish	K	✓	✓	
			Long vent / drain plugs	J	✓	✓	
			FM explosionproof	3	✓	✓	
			ATEX Flameproof	6	✓	✓	
				-			
Options II			No option	XX	✓	✓	
			Water free finish (with oil free finish)	A7	✓	✓	
			NEPSI Flameproof	C1	✓	✓	
			Custom calibration	C7	✓	✓	
			FOUNDATION™ fieldbus *33	D6	✓	✓	
			One elbow	E1	✓	✓	
			Two elbows	E2	✓	✓	
			Mounting bracket	E9	✓	✓	
			PED (97/23/EC) Conformity *34	H1	✓	✓	
			Material certificate	H2	✓	✓	
			Max. working pressure 20 MPa	H3	✓	✓	
			Fieldbus communication stack BASIC class (used with option D6) *33	L1	✓	✓	
			SI unit	U1	✓	✓	

Note) *1 SCS14A (equivalent SUS316) or SUSF316

*3 In case "for oxygen or chlorine (fluorine oil) service" is used, "oil free finish - code K" must be selected.

*12 When SUS304 bolt/nut is selected, max. working pressure rating is 23 MPa (230 kgf/cm²).

*33 "FOUNDATION™ fieldbus - code D6" and "Fieldbus communication stack BASIC class - code L1" must be selected.

*34 "PED Conformity" is not applicable for the combination with FM, CSA or NEPSI approvals.

Model STG981

[Unit: mm]

Process connection: Top or bottom side

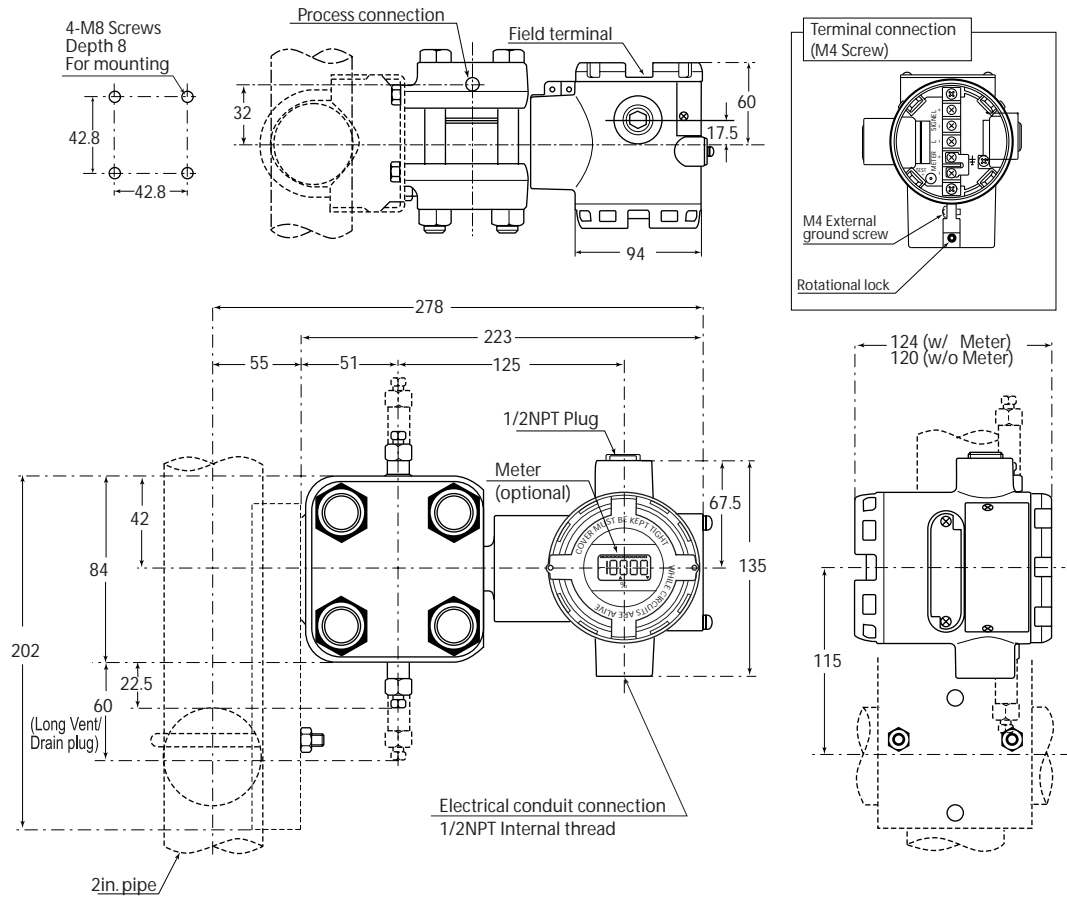

Model STG940 / STG960 (Wetted parts materials: Tantalum, SUS316L)

[Unit: mm]

Process connection: Top or bottom side

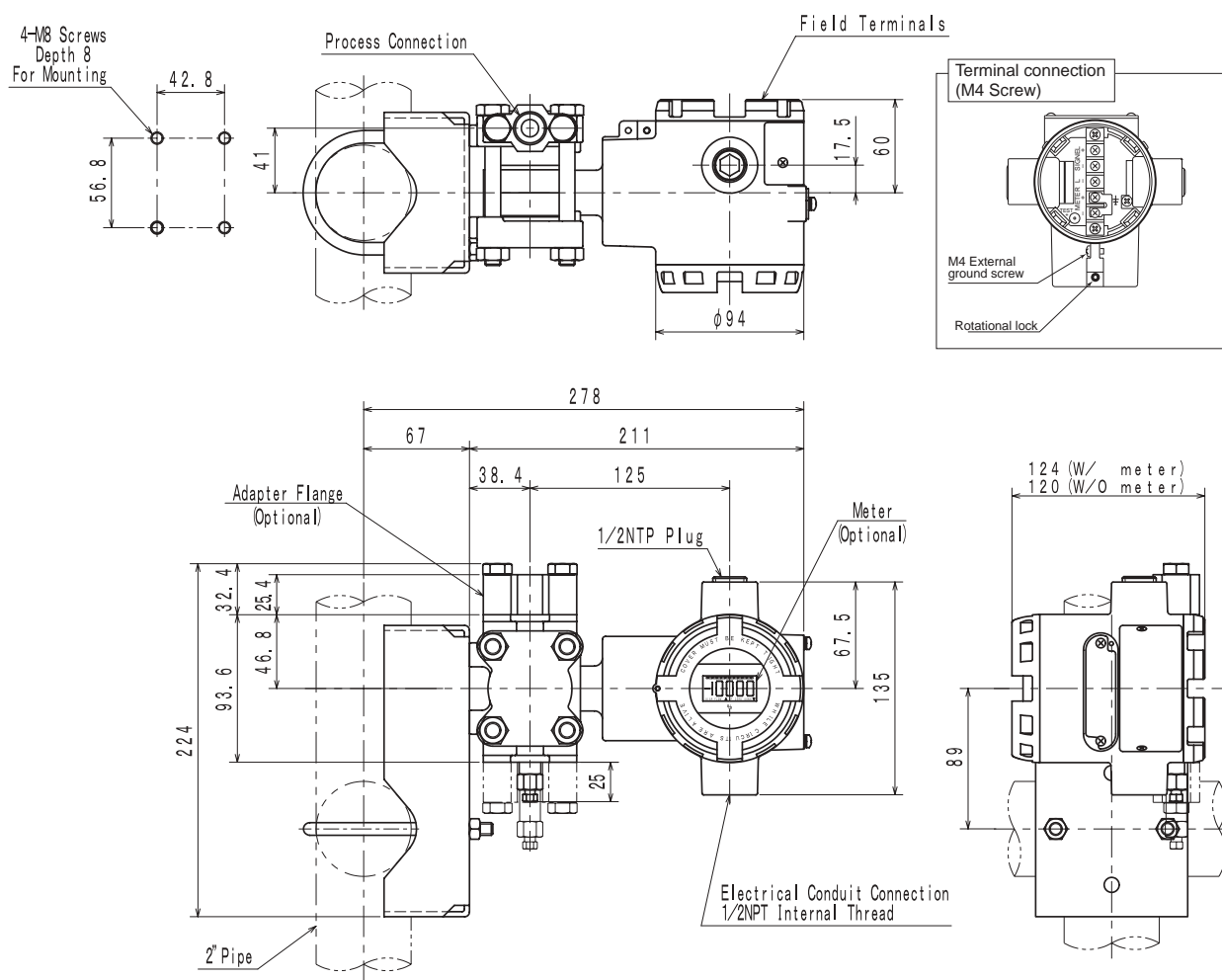

Yamatake Corporation
Advanced Automation Company

1-12-2 Kawana, Fujisawa
Kanagawa 251-8522 Japan

URL: <http://www.azbil.com>