

ST3000 Series 900 Smart Transmitter

Flange type of Differential Pressure Transmitter with FOUNDATION™ fieldbus

Model STC929 / STC940

OVERVIEW

The ST3000 Series 900 with FOUNDATION™ fieldbus is an accurate, stable, and reliable pressure / differential pressure transmitter, which fully complies with the 31.25 kbps voltage mode FOUNDATION™ fieldbus. Its built-in AI function blocks provide process variables to devices on the Fieldbus and its PID control function block enables process control in the field.

Since the ST3000 Series 900 is FOUNDATION™ registered, it can operate seamlessly with other registered field devices as well as host systems in a wide range of control applications.

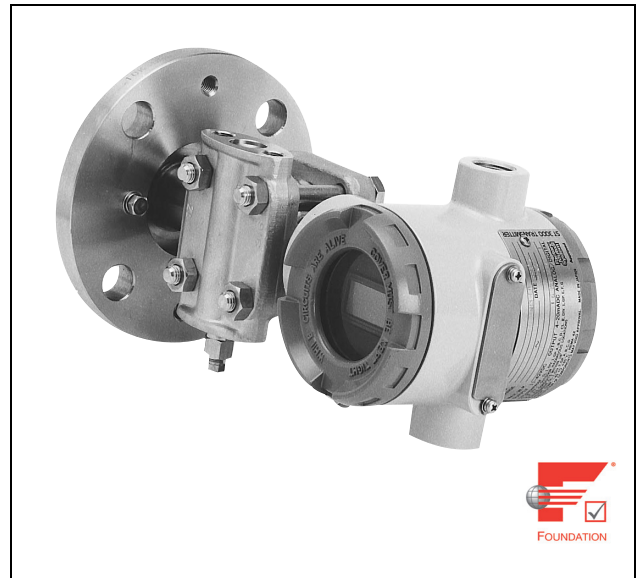

FEATURES

Excellent stability and high performance

- Long-term stability is proven in 500,000 installations worldwide.
- Unique characterization and composite semiconductor sensors realize excellent temperature and static pressure characteristics.

A diverse lineup

- A diverse flange lineup, ranging from small diameter 1.5 in. (40 mm) and 2 in. (50 mm) to 3 in. (80 mm), is available to meet user requirements.
- A wide variety of models, including those for standard differential pressure and high differential pressure, is available to meet user requirements.
- A wide variety of corrosion-resistant materials for wetted parts is also available.

FOUNDATION™ is a registered trademark of the Fieldbus Foundation.

APPLICATION

Petroleum / Petrochemical / Chemical

For measuring pressures, liquid levels, and ordinary surface levels in tanks of all sizes.

Electric power / City gas / Other utilities

For measurement applications that require high degrees of stability and accuracy.

Pulp and paper

- For measuring pressures, liquid levels, and boundary surface levels in tanks
- For measuring pressures, liquid levels, and boundary surface levels in tanks

Iron and steel / Nonferrous metal / Ceramics

For lines that require stable measurement under strictly controlled (temperature, humidity, etc.) conditions.

Machinery / Shipbuilding

For lines that require stable measurement under strictly controlled (temperature, humidity, etc.) conditions.

FUNCTIONAL SPECIFICATIONS

Type of protection

JIS C0920 watertight: NEMA3 and 4X
 JIS F8001 class 2 watertight: IEC IP67

FM Explosionproof approval

Explosionproof for Class I (Gas, steam), Division 1, Group A, B, C, D

Dust-ignition for Class II (Inflammable dust), Division 1, Group E, F, G

Suitable for Class III (inflammable fiber), Division 1

Nonincendive for Class I, Division 2, Group A, B, C, D

ATEX Flameproof approval

Ⓔ II 2 GD EEx d IIC T6 at $-20 \leq T_{amb} \leq +60^{\circ}\text{C}$

NEPSI Flameproof approval

Ex d IIC T6 (with NEPSI Dust Ignition DIP DT T13)

Measuring span / Setting range / Working pressure range

	Measuring span	Setting range	Working pressure range
STC 929	2.5 ~ 100 kPa {250 ~ 10160 mmH ₂ O}	-100 ~ 100 kPa {-10160 ~ 10160 mmH ₂ O}	Up flange rating (for negative pressures, see Figure 1 and Figure 2)
STC 940	35 ~ 3500 kPa {0.35 ~ 35 kgf/cm ² }	-100 ~ 3500 kPa {-1 ~ 35 kgf/cm ² }	

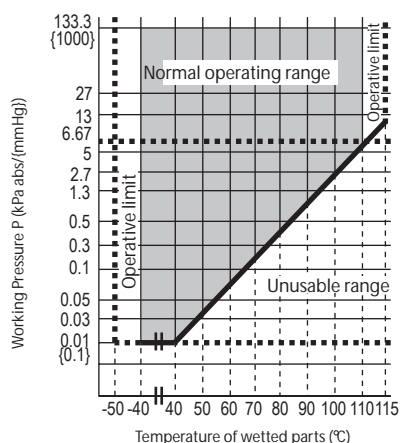

Figure 1 Working pressure and temperature of wetted parts section

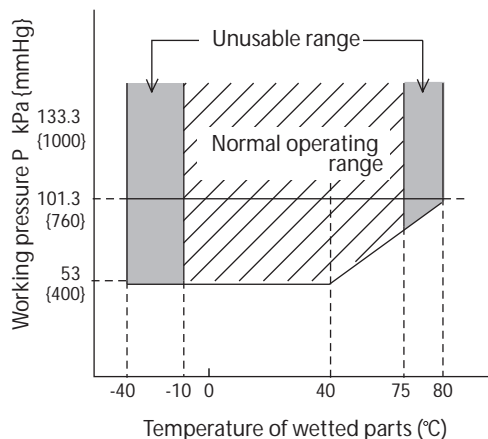

Figure 2 Working pressure and temperature of wetted parts section (for oxygen and chlorine service)

Supply voltage

9 to 32 V DC.

Ambient temperature limits

Normal operating range

-30 to 75°C for general purpose models
 -10 to 75°C for oxygen and chlorine models
 -20 to 70°C for models with digital indicators

Operative limit

-50 to 80°C for general purpose models
 -40 to 80°C for oxygen and chlorine models
 -30 to 80°C for models with digital indicators

Temperature ranges of wetted parts

Normal operating range

-40 to 110°C for general purpose models
 -10 to 75°C for oxygen and chlorine models

Operative limit

-50 to 115°C for general purpose models
 -40 to 80°C for oxygen and chlorine models

Ambient humidity limits

5 to 100% RH

Stability against supply voltage change

± 0.005% FS/V

Lightning protection

Peak value of voltage surge: 12 kV

Peak value of current surge: 1000 A

Optional specifications

Built-in indicating meter

The digital LCD indicator (optional) indicates engineering units and can be set freely between -19999 and 19999 (4.5 digits).

Bolts and nuts materials (for fastening meter body cover)

Carbon steel (SNB7), SUS304, SUS630

(Pressure rating 7000 kPa {70 kgf/cm²} or flange rating)

Baked acrylic paint.

Corrosion-resistant finish

Corrosion-resistant finish

Corrosion-resistant paint (baked acrylic paint), fungus-proof finish.

Corrosion-proof finish

Corrosion-proof paint (baked epoxy paint), fungus-proof finish.

Corrosion-resistant finish (silver paint)

Transmitter case is coated with silver paint in addition to the above corrosion-resistant finish.

FEP protective film

Use FEP protective films when corrosive fluids are used or to avoid metal ions contact.

Working temperature range

0 to 110°C

Working pressure range

Atmospheric pressure to flange rating

(Up to JIS 10K, ANSI / JPI 150)

(Not usable under negative pressure)

Oil free finish

The transmitter is shipped with oil-free wetted parts.

Elbow

This is an adaptor for changing the electrical conduit connection port from the horizontal to the vertical direction, if required by wiring conditions in the field. One or two elbows may be used as needed.

Conformance to SI units

We deliver transmitters set to any SI units as specified.

PHYSICAL SPECIFICATIONS**Materials****Fill fluid**

Silicone oil for general purpose models
Fluorine oil for oxygen and chlorine models

Center body

SUS316

Transmitter case

Aluminum alloy

Meter body cover

SCS14A (equivalent to SUS316) or SUSF316

For Wetted parts**Adapter flange (option)**

SCS14A (equivalent to SUS316)

Center body

SUS316 (SUS316L for diaphragm only)
Hastelloy C, Tantalum, SUS316L

Vents and plugs

SUS316

Gaskets

FEP

Flange materials

Carbon steel (SF440A), SUS304, SUS316, SUS316L

Finish

Housing light beige (Munsell 4Y7.2/1.3)

Cap dark beige (Munsell 10YR4.7/0.5)

Weight

Approx. 6.4 kg (in case of JIS 10K-40A flange)

INSTALLATION**Electrical connection**

1/2NPT internal thread

Grounding

Resistance 100 Ω max.

Mounting

Direct mounting on the process side

Process connection**Measured pressure (liquid side)****Flush diaphragm**

JIS10K, 20K and 30K: 40 mm/ 50 mm/ 80 mm (RF) equivalent

ANSI 150, 300 and 600: 1.5 in./ 2 in./ 3 in. (RF) equivalent

JPI 150, 300 and 600: 1.5 in./ 2 in./ 3 in. (RF) equivalent

Extended diaphragm

JIS10K, 20K, 30K: 50 mm/ 80 mm/ 100 mm (RF) equivalent

ANSI 150 and 300: 2 in./ 3 in./ 4 in. (RF) equivalents

JPI 150 and 300: 2 in./ 3 in./ 4 in. (RF) equivalents

Standard pressure side

Rc1/2, 1/2NPT internal thread, Rc1/4, 1/4NPT internal thread, atmospheric disconnection hole.

PERFORMANCE SPECIFICATIONS

Max working pressure

- Note) 1. Max working pressure depends on flange rating, flange materials and operating temperature. Please refer to the following data. Operating range of temperature depends on specification of transmitters.
- Note) 2. In case of flange type (STC940□) and remote scaled type (STU940□, STH940□), max working pressure depends on the smaller value of either 1.5 MPa or following data.
- Note) 3. In case of remote scaled type (STH960□), max working pressure depends on the smaller value of either 10 MPa or following data.

	JIS	JPI/ANSI
SUS304		
SUS316		
SUS316L		

Accuracy

Shown for each item is the percentage ratio for χ (kPa), which is the greatest value of either XD_SCALE_EU_100^(*1), XD_SCALE_EU_0^(*2), or the span.

Model STC929

(Material of Wetted Parts at Flange Side: Diaphragm; SUS316L Others; SUS316, Material of Wetted parts at reference side: Diaphragm; SUS316L, Others; SUS316)

Accuracy	Linear output:	$\pm 0.2\%$	(For $\chi \geq 12.5kPa$ {1250 mmH ₂ O})
		$\pm\left(0.05 + 0.15 \times \frac{12.5}{\chi}\right) \%$	(For $\chi < 12.5kPa$ {1250 mmH ₂ O})
Temperature characteristics (Shift from the set range) Change of 55°C	Zero shift:	$\pm\left(0.25 + 0.9 \times \frac{12.5}{\chi}\right) \%$	
	Combined shift: (including zero and span shifts)	$\pm 1.45\%$	(For $\chi \geq 12.5kPa$ {1250 mmH ₂ O})
		$\pm\left(0.35 + 1.1 \times \frac{12.5}{\chi}\right) \%$	(For $\chi < 12.5kPa$ {1250 mmH ₂ O})
Static pressure effect (Shift in respect to setting range) Change of 7 MPa {70 kgf/cm ² }	Zero shift:	$\pm 0.7\%$	(For $\chi \geq 25kPa$ {2500 mmH ₂ O})
		$\pm\left(0.7 \times \frac{25}{\chi}\right) \%$	(For $\chi < 25kPa$ {2500 mmH ₂ O})
	Combined shift: (including zero and span shifts)	$\pm 1.0\%$	(For $\chi \geq 25kPa$ {2500 mmH ₂ O})
		$\pm\left(1.0 \times \frac{25}{\chi}\right) \%$	(For $\chi < 25kPa$ {2500 mmH ₂ O})

Model STC940

(Material of Wetted Parts at Flange Side: Diaphragm; SUS316L Others; SUS316, Material of Wetted parts at reference side: Diaphragm; SUS316L, Others; SUS316)

Accuracy (*3)	Linear output:	$\pm 0.15\%$	(For $\chi \geq 350kPa$ {3.5 kgf/cm ² })
		$\pm\left(0.05 + 0.1 \times \frac{350}{\chi}\right) \%$	(For $\chi < 350kPa$ {3.5 kgf/cm ² })
Temperature characteristics (Shift from the set range) (*3) Change of 55°C	Zero shift:	$\pm\left(0.25 + 0.2 \times \frac{350}{\chi}\right) \%$	
	Combined shift: (including zero and span shifts)	$\pm 0.75\%$	(For $\chi \geq 350kPa$ {3.5 kgf/cm ² })
		$\pm\left(0.35 + 0.4 \times \frac{350}{\chi}\right) \%$	(For $\chi < 350kPa$ {3.5 kgf/cm ² })
Static pressure effect (Shift in respect to setting range) (*3) Change of 7 MPa {70 kgf/cm ² }	Zero shift:	$\pm\left(0.03 + 7.5 \times \frac{350}{\chi}\right) \%$	
	Combined shift: (including zero and span shifts)	$\pm 9.00\%$	(For $\chi \geq 350kPa$ {3.5 kgf/cm ² })
		$\pm\left(1.5 + 7.5 \times \frac{350}{\chi}\right) \%$	(For $\chi < 350kPa$ {3.5 kgf/cm ² })

Note (*1): XD_SCALE_EU_100 denotes the upper limit of the calibration range.

(*2): XD_SCALE_EU_0 denotes the lower limit of the calibration range.

(*3): Within a range of XD_SCALE_EU_100 ≥ 0 and XD_SCALE_EU_0 ≥ 0 .

Model STC929

(Material of Wetted Parts at Flange Side: Diaphragm; Hastelloy C, Tantalum, SUS316L Others; Hastelloy C, Tantalum, SUS316L, Material of Wetted parts at reference side: Diaphragm; SUS316L, Others; SUS316)

Accuracy	Linear output:	$\pm 0.4\%$	(For $\chi \geq 12.5kPa$ {1250 mmH ₂ O})
		$\pm\left(0.25 + 0.15 \times \frac{12.5}{\chi}\right)\%$	(For $\chi < 12.5kPa$ {1250 mmH ₂ O})
Temperature characteristics (Shift from the set range) 30°C (Range from -5 to 55°C)	Zero shift:	$\pm\left(0.15 + 2.35 \times \frac{2.5}{\chi}\right)\%$	
	Combined shift: (including zero and span shifts)	$\pm\left(0.6 + 2.4 \times \frac{25}{\chi}\right)\%$	
Static pressure effect (Shift in respect to setting range) Change of 7 MPa {70 kgf/cm ² }	Zero shift:	$\pm 2.0\%$	(For $\chi \geq 25kPa$ {2500 mmH ₂ O})
		$\pm\left(2.0 \times \frac{25}{\chi}\right)\%$	(For $\chi < 25kPa$ {2500 mmH ₂ O})
	Combined shift:	$\pm 2.5\%$	(For $\chi \geq 25kPa$ {2500 mmH ₂ O})
	(including zero and span shifts)	$\pm\left(2.5 \times \frac{25}{\chi}\right)\%$	(For $\chi < 25kPa$ {2500 mmH ₂ O})

Model STC940

(Material of Wetted Parts at Flange Side: Diaphragm; Hastelloy C, Tantalum, SUS316L Others; Hastelloy C, Tantalum, SUS316L, Material of Wetted parts at reference side: Diaphragm; SUS316L, Others; SUS316)

Accuracy (*3)	Linear output:	$\pm 0.3\%$	(For $\chi \geq 350kPa$ {3.5 kgf/cm ² })
		$\pm\left(0.15 + 0.15 \times \frac{350}{\chi}\right)\%$	(For $\chi < 350kPa$ {3.5 kgf/cm ² })
Temperature characteristics (Shift from the set range) Change of 30°C (*3) (Range from -5 to 55°C)	Zero shift:	$\pm\left(0.15 + 0.4 \times \frac{350}{\chi}\right)\%$	
	Combined shift: (including zero and span shifts)	$\pm 1.0\%$	(For $\chi \geq 350kPa$ {3.5 kgf/cm ² })
		$\pm\left(0.35 + 0.65 \times \frac{350}{\chi}\right)\%$	(For $\chi < 350kPa$ {3.5 kgf/cm ² })
Static pressure effect (Shift in respect to setting range) (*3)	Zero shift:	$\pm\left(0.03 + 7.5 \times \frac{350}{\chi}\right)\%$	
	Combined shift:	$\pm 9.0\%$	(For $\chi \geq 350kPa$ {3.5 kgf/cm ² })
	(including zero and span shifts)	$\pm\left(1.5 + 7.5 \times \frac{350}{\chi}\right)\%$	(For $\chi < 350kPa$ {3.5 kgf/cm ² })

Note) (*3): Within a range of $XD_SCALE_EU_100 \geq 0$ and $XD_SCALE_EU_0 \geq 0$.

FIELDBUS SPECIFICATIONS**Block supported by the S900**

Name of block	Number of block	Description	Max. execution time msec.
Resource block	1	The Resource Block (RB) maintains overall resources of the S900.	-
Transducer block	1	The Transducer Block (XB) interfaces with the sensing element of the S900, converts the measured value into specified engineering unit, and sends it to the AI Function Block.	-
AI Function Block	2	The AI Function Block (AI FB) accepts an analog input signal from the XB, scales it, detects alarm conditions, and provides it in a uniform format on the Fieldbus network.	75
Diagnostics Block	1	The Diagnostics Block (DB) is Yamatake proprietary block which provides the result of self-diagnostics of the S900.	-
PID Function Block	1	The PID Function Block (PID FB) accepts a process variable (PV) from an AI Function Block on the Fieldbus network, calculates the valve position using the PID algorithm, and sends a new valve output signal to the AO Function Block.	125

VCR structure

The S900 has 16 VCRs (Virtual Communication Relationships), of which the first one is dedicated to the SMIB/NMIB as defined by Foundation Fieldbus specifications. The rest of the VCRs are fully configurable. Their default configurations are shown below:

VCR No.	Configuration	VCR No.	Configuration
1	QUB (Server) for NIMIB/SMIB	9	QUU (Source)
2	BNU (Subscriber)	10	QUU (Source)
3	BNU (Subscriber)	11	QUU (Source)
4	BNU (Subscriber)	12	QUB (Server)
5	BNU (Subscriber)	13	QUB (Server)
6	BNU (Publisher)	14	QUB (Server)
7	BNU (Publisher)	15	QUB (Server)
8	QUU (Source)	16	QUB (Server)

Network parameters

The following table lists the key parameter values that affect the interoperability of the Fieldbus devices. The LAS must be configured to satisfy these parameters. If other devices on the same Fieldbus network require a greater number for them, the greater number must be used. This however will degrade network performance.

Symbol	Parameter name	Range of value
V (ST)	Slot Time	4 to 100
V (MID)	Minimum Interframe Gap	10 to $(V (MRD) - 1) \times V (ST)$, less than 120 inclusive.
V (MRD)	Maximum Response Delay	$V (MRD) \times V (ST)$ shall be greater than 20 and $V (MRD)$ shall be less than 11, inclusive.
T1	SM step timer	96000 (3 seconds)
T2	SM set address sequence timer	1920000 (60 seconds)
T3	SM set address wait timer	480000 (15 seconds)

Note) An LAS requires parameters other than those listed here for operation. Please refer to the user's manual that is provided with your LAS device.

Note) The T3 must be set between 15 seconds and 60 seconds.

MODEL SELECTION

ST3000 Series 900 electric differential pressure transmitter

Model STC929 (Flange type for medium differential pressure)

Model STC940 (Flange type for high differential pressure)

Model No.: STC929 - I II III IV V VI VII VIII - Option I - Option II

Model No.: STC940 - I II III IV V VI VII VIII - Option I - Option II

Basic Model No.

Measuring span	2.5 to 100 kPa (250 to 10,160 mmH ₂ O)	STC929	Flush flange type 3 in. (80 mm)
	35 to 3500 kPa (0.35 to 35 kgf/cm ²)	STC940	

Selection I			Code	Material Code							
I	Material	Reference side meter body cover	Adapter flange	Vent / drain plugs	Wetted parts of flange side center body	Wetted parts of reference side center body	-	E	F	H	U
		SCS14A*1	SCS14A*1	SUS316	Diaphragm:SUS316L Others: SUS316	Diaphragm:SUS316L Others: SUS316	E				
		SCS14A*1	SCS14A*1	SUS316	Diaphragm: Hastelloy C Others: Hastelloy C	Diaphragm:SUS316L Others: SUS316	F				
		SCS14A*1	SCS14A*1	SUS316	Diaphragm: Tantalum Others: Tantalum	Diaphragm:SUS316L Others: SUS316	H				
		SCS14A*1	SCS14A*1	SUS316	Diaphragm:SUS316L Others: SUS316L	Diaphragm:SUS316L Others: SUS316	U				
II	Fill fluid	Regular type (Silicone oil)				1	✓	✓	✓	✓	
		For oxygen service (Fluorine oil) *3				2	✓	✓	✓	✓	
		For chlorine service (Fluorine oil) *3				5			✓		
III	Process connection	Top or bottom connection	Rc1/2 with adapter flange			Q	✓	✓	✓	✓	
			1/2NPT internal thread with adapter flange			R	✓	✓	✓	✓	
			Rc1/4 with adapter flange			S	✓	✓	✓	✓	
			1/4NPT internal thread with adapter flange			T	✓	✓	✓	✓	
			1/4NPT internal thread on head			U	✓	✓	✓	✓	
			Open to atmosphere			H	✓	✓	✓	✓	
IV	Flange standard	ANSI flange			A	✓	✓	✓	✓		
		JIS flange			J	✓	✓	✓	✓		
		JPI flange			P	✓	✓	✓	✓		
V	Flange type & rating	Standard	JIS 10K, ANSI/JPI 150 (RF) equivalent			A	✓	✓	✓	✓	
			JIS 20K, ANSI/JPI 300 (RF) equivalent			B	✓	✓	✓	✓	
			JIS 30K, ANSI/JPI 600 (RF) equivalent			C	✓	✓	✓	✓	
VI	Flange material	SUS304			7	✓	✓	✓	✓		
		SUS316			2	✓	✓	✓	✓		
		SUS316L			8	✓	✓	✓	✓		
VII	Finish of gasket face	Standard (JIS Ra3.2 (12.5S))			J	✓	✓	✓	✓		
VIII	Length of extended parts	Flush diaphragm 3 in. (80 mm)			00	✓	✓	✓	✓		

(Continued)

(Continued from previous page)

Model No.: STC929 - I II III IV V VI VII VIII - **Option I - Option II**Model No.: STC940 - I II III IV V VI VII VIII - **Option I - Option II**

		Code	Material Code			
			E	F	H	U
Options I	No options	X	✓	✓	✓	✓
	Built-in indicating smart meter (0 to 100% liner scales)	P	✓	✓	✓	✓
	Built-in indicating smart meter (engineering unit scales)	R	✓	✓	✓	✓
	SUS304 bolt and nuts material	W	✓	✓	✓	✓
	SUS630 bolt and nuts material	U	✓	✓	✓	✓
	Corrosion-resistant finish	A	✓	✓	✓	✓
	Corrosion-proof finish	B	✓	✓	✓	✓
	Corrosion-resistant finish, silver paint	D	✓	✓	✓	✓
	FEP protective film	T	✓	✓	✓	✓
	Oil free finish	K	✓	✓	✓	✓
	Long vent/drain plugs	J	✓	✓	✓	✓
	FM Explosionproof	3	✓	✓	✓	✓
	ATEX Flameproof	6	✓	✓	✓	✓
		-				
Options II	No option	XX	✓	✓	✓	✓
	Water free finish (with oil free finish)	A7	✓	✓	✓	✓
	NEPSI Flameproof	C1	✓	✓	✓	✓
	Custom calibration	C7	✓	✓	✓	✓
	FOUNDATION™ fieldbus *33	D6	✓	✓	✓	✓
	One elbow	E1	✓	✓	✓	✓
	Two elbows	E2	✓	✓	✓	✓
	0.1 mm thickness diaphragm *15	F4	✓			✓
	Material certificate	H2	✓	✓	✓	✓
	Fieldbus communication stack BASIC class (used with option D6) *33	L1	✓	✓	✓	✓
	SI unit	U1	✓	✓	✓	✓

Note) *1 SCS14A (Equivalent SUS316) or SUSF316.

*3 In case "for oxygen or chlorine (fluorine oil) service" is used, "oil free finish - code K" must be selected.

*15 Only available for material of wetted parts: "SUS316" or "SUS316L".

*33 "FOUNDATION™ fieldbus - code D6" and "Fieldbus communication stack BASIC class - code L1" must be selected.

ST3000 Series 900 electric differential pressure transmitter
Model STC929 (Flange type for medium differential pressure)
Model STC940 (Flange type for high differential pressure)

Model No.: STC929 - I II III IV V VI VII VIII - Option I - Option II

Model No.: STC940 - I II III IV V VI VII VIII - Option I - Option II

Basic Model No.

Measuring span	2.5 to 100 kPa (250 to 10,160 mmH ₂ O)	STC929	Extended flange type 4 in. (100 mm)
	35 to 3500 kPa (0.35 to 35 kgf/cm ²)	STC940	

Selection I						Code	Material code		
I	Material	Reference side meter body cover	Adapter flange	Vent/drain plugs	Wetted parts of flange side center body	Wetted parts of reference side center body		E	U
		SCS14A*1	SCS14A*1	SUS316	Diaphragm:SUS316L Others: SUS316	Diaphragm:SUS316L Others: SUS316	E		
		SCS14A*1	SCS14A*1	SUS316	Diaphragm:SUS316L Others: SUS316	Diaphragm:SUS316L Others: SUS316	U		
II	Fill fluid	Regular type (Silicon oil)				1	✓	✓	
		For oxygen service (Fluorine oil) *3				2	✓	✓	
III	Process connection	Top or bottom connection	Rc1/2 with adapter flange			Q	✓	✓	
			1/2NPT internal thread with adapter flange			R	✓	✓	
			Rc1/4 with adapter flange			S	✓	✓	
			1/4NPT internal thread with adapter flange			T	✓	✓	
			1/4NPT internal thread on head			U	✓	✓	
			Open to atmosphere			H	✓	✓	
IV	Flange standard	ANSI flange				A	✓	✓	
		JIS flange				J	✓	✓	
		JPI flange				P	✓	✓	
V	Flange type & rating	Standard	JIS 10K, ANSI/JPI 150 (RF) equivalent			A	✓	✓	
			JIS 20K, ANSI/JPI 300 (RF) equivalent			B	✓	✓	
			JIS 30K *30			C	✓	✓	
VI	Flange material	SUS304				7	✓	✓	
		SUS316				2	✓	✓	
		SUS316L *30				8	✓	✓	
VII	Finish of gasket face	Standard (JIS Ra3.2 (12.5S))				J	✓	✓	
VIII	Length of extended parts	L = 50 mm (4 in. / 100 mm)				09	✓	✓	
		L = 100 mm (4 in. / 100 mm)				14	✓	✓	
		L = 150 mm (4 in. / 100 mm)				19	✓	✓	
		L = 200 mm (4 in. / 100 mm)				24	✓	✓	
		L = 250 mm (4 in. / 100 mm)				29	✓	✓	
		L = 300 mm (4in. / 100 mm) *30				34	✓	✓	

(Continued)

(Continued from previous page)

Model No.: STC929 - I II III IV V VI VII VIII - **Option I - Option II**Model No.: STC940 - I II III IV V VI VII VIII - **Option I - Option II**

		Code	Material Code	
			E	U
Options I	No options	X	✓	✓
	Built-in indicating smart meter (0 to 100% liner scales)	P	✓	✓
	Built-in indicating smart meter (engineering unit scales)	R	✓	✓
	SUS304 bolt and nuts material	W	✓	✓
	SUS630 bolt and nuts material	U	✓	✓
	Corrosion-resistant finish	A	✓	✓
	Corrosion-proof finish	B	✓	✓
	Corrosion-resistant finish, silver paint	D	✓	✓
	Oil free finish	K	✓	✓
	Long vent/drain plugs	J	✓	✓
	FM Explosionproof	3	✓	✓
	ATEX Flameproof	6	✓	✓
		-		
Options II	No option	XX	✓	✓
	Water free finish (with oil free finish)	A7	✓	✓
	NEPSI Flameproof	C1	✓	✓
	Custom calibration	C7	✓	✓
	FOUNDATION™ fieldbus *33	D6	✓	✓
	One elbow	E1	✓	✓
	Two elbows	E2	✓	✓
	0.1 mm thickness diaphragm	F4	✓	✓
	Material certificate	H2	✓	✓
	Fieldbus communication stack BASIC class (used with option D6) *33	L1	✓	✓
	SI unit	U1	✓	✓

Note) *1 SCS14A (Equivalent SUS316) or SUSF316

*3 In case "for oxygen or chlorine (fluorine oil) service" is used, "oil free finish - code K" must be selected.

*30 In case flange rating: JIS30K, Wetted parts material: SUS316L and for high temperature service, extension length of flange 300 mm is not available.

*33 "FOUNDATION™ fieldbus - code D6" and "Fieldbus communication stack BASIC class - code L1" must be selected.

ST3000 Series 900 electric differential pressure transmitter
Model STC929 (Flange type for medium differential pressure)
Model STC940 (Flange type for high differential pressure)

Model No.: STC929 - I II III IV V VI VII VIII - Option I - Option II

Model No.: STC940 - I II III IV V VI VII VIII - Option I - Option II

Basic Model No.

Measuring span	2.5 to 100 kPa (250 to 10,160 mmH ₂ O)	STC929	Flush flange type 2 in.(50 mm), 1.5 in.(40 mm)
	35 to 3500 kPa (0.35 to 35 kgf/cm ²)	STC940	

Selection I			Code	Material code							
				E	F	H	U				
I	Material	Reference side meter body cover	Adapter flange	Vent/drain plugs	Wetted parts of flange side center body	Wetted parts of reference side center body					
		SCS14A*1	SCS14A*1	SUS316	Diaphragm:SUS316L Others: SUS316	Diaphragm:SUS316L Others: SUS316	E				
		SCS14A*1	SCS14A*1	SUS316	Diaphragm: Hastelloy C Others: Hastelloy C	Diaphragm:SUS316L Others: SUS316	F				
		SCS14A*1	SCS14A*1	SUS316	Diaphragm: Tantalum Others: Tantalum	Diaphragm:SUS316L Others: SUS316	H				
		SCS14A*1	SCS14A*1	SUS316	Diaphragm:SUS316L Others: SUS316L	Diaphragm:SUS316L Others: SUS316	U				
II	Fill fluid	Regular type (Silicone oil)					1	✓	✓	✓	✓
		For oxygen service (Fluorine oil) *3					2	✓	✓	✓	✓
		For chlorine service (Fluorine oil) *3					5			✓	
III	Process connection	Top or bottom connection	Rc1/2 with adapter flange			Q	✓	✓	✓	✓	
			1/2NPT internal thread with adapter flange			R	✓	✓	✓	✓	
			Rc1/4 with adapter flange			S	✓	✓	✓	✓	
			1/4NPT internal thread with adapter flange			T	✓	✓	✓	✓	
			1/4NPT internal thread on head			U	✓	✓	✓	✓	
			Open to atmosphere			H	✓	✓	✓	✓	
IV	Flange standard	ANSI flange			A	✓	✓	✓	✓		
		JIS flange			J	✓	✓	✓	✓		
		JPI flange			P	✓	✓	✓	✓		
V	Flange type & rating	Standard	JIS 10K, ANSI/JPI 150 (RF) equivalent			A	✓	✓	✓	✓	
			JIS 20K, ANSI/JPI 300 (RF) equivalent			B	✓	✓	✓	✓	
			JIS 30K, ANSI/JPI 600 (RF) equivalent			C	✓	✓	✓	✓	
VI	Flange material	SUS304			7	✓	✓	✓	✓		
		SUS316			2	✓	✓	✓	✓		
		SUS316L			8	✓	✓	✓	✓		
VII	Finish of gasket face	Standard (JIS Ra3.2 (12.5S))			J	✓	✓	✓	✓		
VIII	Length of extended parts	Flush diaphragm 2 in. (50 mm)			01	✓	✓	✓	✓		
		Flush diaphragm 1.5 in. (40 mm)			02	✓	✓		✓		

(Continued)

(Continued from previous page)

Model No.: STC929 - I II III IV V VI VII VIII - **Option I - Option II**Model No.: STC940 - I II III IV V VI VII VIII - **Option I - Option II**

		Code	Material Code			
			E	F	H	U
Options I	No options	X	✓	✓	✓	✓
	Built-in indicating smart meter (0 to 100% liner scales)	P	✓	✓	✓	✓
	Built-in indicating smart meter (engineering unit scales)	R	✓	✓	✓	✓
	SUS304 bolt and nuts material	W	✓	✓	✓	✓
	SUS630 bolt and nuts material	U	✓	✓	✓	✓
	Corrosion-resistant finish	A	✓	✓	✓	✓
	Corrosion-proof finish	B	✓	✓	✓	✓
	Corrosion-resistant finish, silver paint	D	✓	✓	✓	✓
	FEP protective film	T	✓	✓	✓	✓
	Oil free finish	K	✓	✓	✓	✓
	Long vent/drain plugs	J	✓	✓	✓	✓
	FM Explosionproof	3	✓	✓	✓	✓
	ATEX Flameproof	6	✓	✓	✓	✓
		-				
Options II	No option	XX	✓	✓	✓	✓
	Water free finish (with oil free finish)	A7	✓	✓	✓	✓
	NEPSI Flameproof	C1	✓	✓	✓	✓
	Custom calibration	C7	✓	✓	✓	✓
	FOUNDATION™ fieldbus *33	D6	✓	✓	✓	✓
	One elbow	E1	✓	✓	✓	✓
	Two elbows	E2	✓	✓	✓	✓
	Material certificate	H2	✓	✓	✓	✓
	Fieldbus communication stack BASIC class (used with option D6) *33	L1	✓	✓	✓	✓
	SI unit	U1	✓	✓	✓	✓

Note) *1 SCS14A (equivalent SUS316) or SUSF316

*3 In case "for oxygen or chlorine (fluorine oil) service" is used, "oil free finish - code K" must be selected.

*33 "FOUNDATION™ fieldbus - code D6" and "fieldbus communication stack BASIC class - code L1" must be selected.

ST3000 Series 900 electric differential pressure transmitter
Model STC929 (Flange type for medium differential pressure)
Model STC940 (Flange type for high differential pressure)

Model No.: STC929 - I II III IV V VI VII VIII - Option I - Option II

Model No.: STC940 - I II III IV V VI VII VIII - Option I - Option II

Basic Model No.

Measuring span	2.5 to 100 kPa (250 to 10,160 mmH ₂ O)	STC929	Extended flange type 3 in.(80 mm), 2 in.(50 mm)
	35 to 3500 kPa (0.35 to 35 kgf/cm ²)	STC940	

Selection I							Code	Material code	
I	Material	Meter body cover	Adapter flange	Vent/drain Plugs	Wetted parts of flange side center body	Wetted parts of reference side center body		E	U
		SCS14A*1	SCS14A *1	SUS316	Diaphragm: SUS316L Others: SUS316	Diaphragm: SUS316L Others: SUS316	E		
		SCS14A*1	SCS14A *1	SUS316	Diaphragm: SUS316L Others: SUS316L	Diaphragm: SUS316L Others: SUS316	U		
II	Fill fluid	Regular type (Silicon oil)				1	✓	✓	
		For oxygen service (Fluorine oil) *3				2	✓	✓	
III	Process connection	Top or Bottom	Rc1/2 with adapter flange			Q	✓	✓	
			1/2NPT internal thread with adapter flange			R	✓	✓	
			Rc1/4 with adapter flange			S	✓	✓	
			1/4NPT internal thread with adapter flange			T	✓	✓	
			1/4NPT internal thread on head			U	✓	✓	
			Open to atmosphere			H	✓	✓	
IV	Flange standard	ANSI flange				A	✓	✓	
		JIS flange				J	✓	✓	
		JPI flange				P	✓	✓	
V	Flange type & rating	Standard	JIS 10K, ANSI/JPI 150 (RF) equivalent			A	✓	✓	
			JIS 20K, ANSI/JPI 300 (RF) equivalent			B	✓	✓	
			JIS 30K, ANSI/JPI 600 (RF) equivalent *24			C	✓	✓	
VI	Flange material	SUS304				7	✓	✓	
		SUS316				2	✓	✓	
		SUS316L *24				8	✓	✓	
VII	Finish of gasket face	Standard (JIS Ra3.2 (12.5S))				J	✓	✓	
VIII	Length of extended parts	L = 50 mm (3 in. / 80 mm) *24				05	✓	✓	
		L = 100 mm (3 in. / 80 mm) *24				10	✓	✓	
		L = 150 mm (3 in. / 80 mm) *24				15	✓	✓	
		L = 50 mm (2 in. / 50 mm)				06	✓	✓	
		L = 100 mm (2 in. / 50 mm)				11	✓	✓	
		L = 150 mm (2 in. / 50 mm)				16	✓	✓	

(Continued)

(Continued from previous page)

Model No.: STC929 - I II III IV V VI VII VIII - **Option I - Option II**Model No.: STC940 - I II III IV V VI VII VIII - **Option I - Option II**

		Code	Material code	
			E	U
Options I	No options	X	✓	✓
	Built-in indicating smart meter (0 to 100% liner scales)	P	✓	✓
	Built-in indicating smart meter (engineering unit scales)	R	✓	✓
	SUS304 Bolt and nuts material	W	✓	✓
	SUS630 Bolt and nuts material	U	✓	✓
	Corrosion-resistant finish	A	✓	✓
	Corrosion-proof finish	B	✓	✓
	Corrosion-resistant finish, silver paint	D	✓	✓
	Oil free finish	K	✓	✓
	Long vent/drain plugs	J	✓	✓
	FM Explosionproof	3	✓	✓
	ATEX Flameproof	6	✓	✓
		-		
Options II	No option	XX	✓	✓
	Water free finish (with oil free finish)	A7	✓	✓
	NEPSI Flameproof	C1	✓	✓
	Custom calibration	C7	✓	✓
	FOUNDATION™ fieldbus *33	D6	✓	✓
	One elbow	E1	✓	✓
	Two elbows	E2	✓	✓
	Material certificate	H2	✓	✓
	Fieldbus communication stack BASIC class (used with option D6) *33	L1	✓	✓
	SI unit	U1	✓	✓

Note *1 SCS14A (equivalent SUS316) or SUSF316

*3 In case "for oxygen or chlorine (fluorine oil) service" is used, "oil free finish - code K" must be selected.

*24 In case of "ANSI/JPI 600" is used for 3in. flange type and rating, not available for the extended diaphragm flange type.

*33 "FOUNDATION™ fieldbus - code D6" and "Fieldbus communication stack BASIC class - code L1" must be selected.

DIMENSIONS

Model STC929 / 940

[Unit: mm]

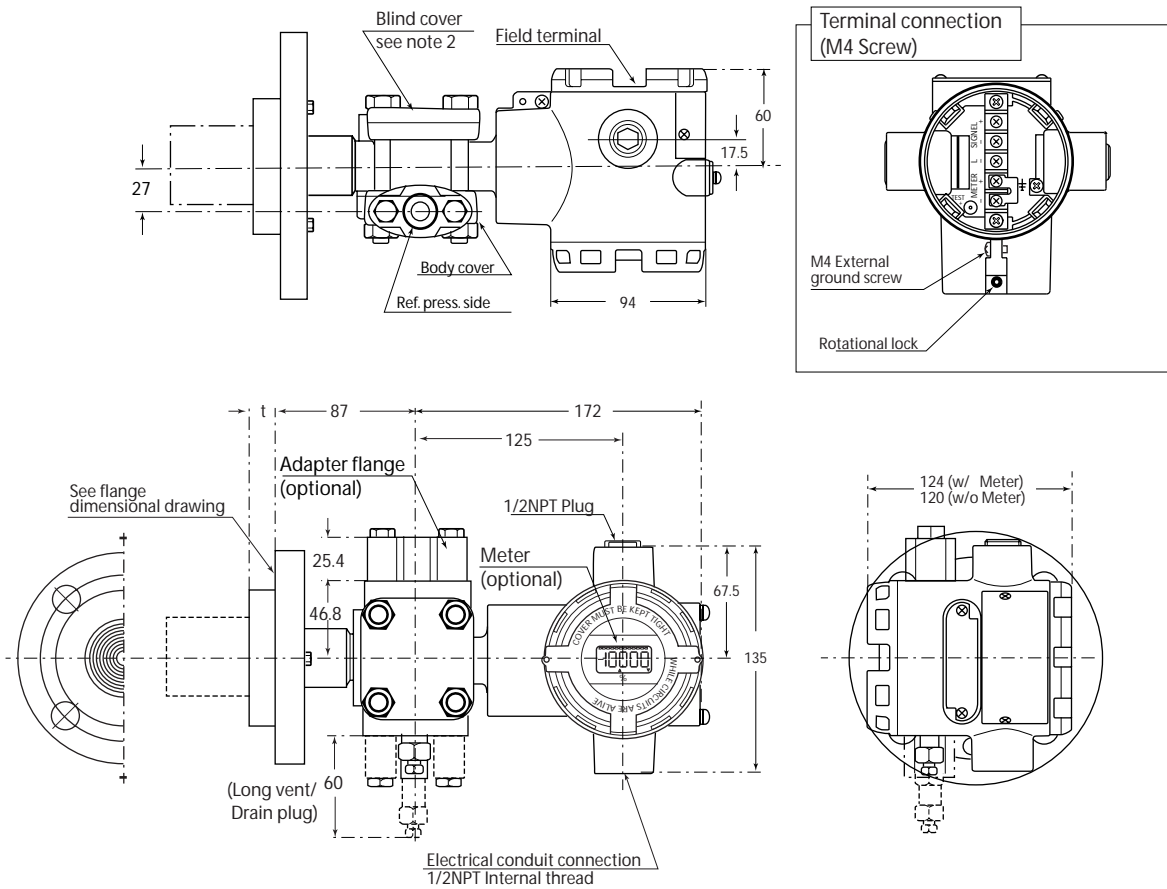

- Note) 1) For the process pipe connection on the standard pressure side, choose either the upward or downward directions. When changing the connection, replace the adaptor flange and the vent/drain plugs.
 2) Select a gasket that will not contact the diaphragm after it is tightened.

Flash diaphragm flange

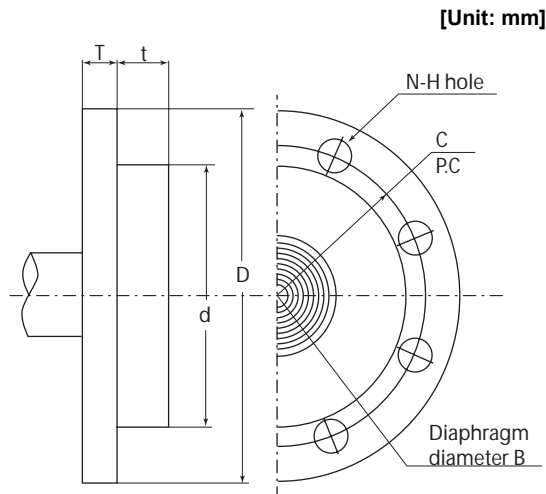

Material of wetted parts	B
SUS316	40
SUS316L	
Hastelloy C	43
Tantalum	62

Rating	Flange rating	D	T	C	N	H	d	t
1.5 in./40mm	JIS 10K - 40 mm	140	18	105	4	19	81	16
	JIS 20K - 40 mm	140	18	105	4	19		
	JIS 30K - 40 mm	160	25	120	4	23		
	ANSI 150 - 1.5 in.	127	18	98.6	4	16		
	ANSI 300 - 1.5 in.	155	25	114.3	4	22		
	ANSI 600 - 1.5 in.	155	32	114.3	4	22		
	JPI 150 - 1.5 in.	127	18	98.6	4	16		
	JPI 300 - 1.5 in.	155	25	114.3	4	22		
	JPI 600 - 1.5 in.	155	32	114.3	4	22		
2 in./50mm	JIS 10K - 50 mm	155	16	120	4	19	99	19
	JIS 20K - 50 mm	155	18	120	8	19		
	JIS 30K - 50 mm	165	22	130	8	19		
	ANSI 150 - 2 in.	152	19.5	120.6	4	19		
	ANSI 300 - 2 in.	165	22.5	127	8	19		
	ANSI 600 - 2 in.	165	25.5	127	8	19		
	JPI 150 - 2 in.	152	19.5	120.6	4	19		
	JPI 300 - 2 in.	165	22.5	127	8	19		
	JPI 600 - 2 in.	165	25.5	127	8	19		
3 in./80mm	JIS 10K - 80 mm	185	18	150	8	19	129.5	22
	JIS 20K - 80 mm	200	22	160	8	23		
	JIS 30K - 80 mm	210	28	170	8	23		
	ANSI 150 - 3 in.	190	24	152.4	4	19		
	ANSI 300 - 3 in.	210	28.5	168.1	8	22		
	ANSI 600 - 3 in.	210	32	168.1	8	22		
	JPI 150 - 3 in.	190	24	152.4	4	19		
	JPI 300 - 3 in.	210	28.5	168.1	8	22		
	JPI 600 - 3 in.	210	32	168.1	8	22		

External diaphragm flange

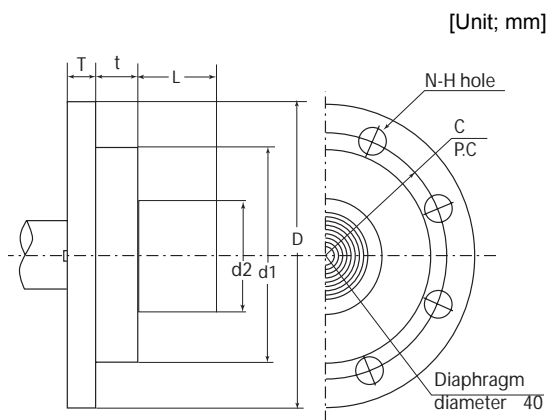

Rating	Flange rating	D	T	C	N	H	d1	d2	t	B	L
2 in./50mm	JIS 10K - 50 mm	155	16	120	4	19	99	47±1	19	40	50
	JIS 20K - 50 mm	155	18	120	8	19					100
	JIS 30K - 50 mm	165	22	130	8	19					150
	ANSI 150 - 2 in.	152	19.5	120.6	4	19					200
	ANSI 300 - 2 in.	165	22.5	127	8	19					250
	ANSI 600 - 2 in.	165	25.5	127	8	19					300
	JPI 150 - 2 in.	152	19.5	120.6	4	19					
	JPI 300 - 2 in.	165	22.5	127	8	19					
	JPI 600 - 2 in.	165	25.5	127	8	19					
3 in./80mm	JIS 10K - 80 mm	185	18	150	8	19	129.5	69±1	22	40	
	JIS 20K - 80 mm	200	22	160	8	23					
	JIS 30K - 80 mm	210	28	170	8	23					
	ANSI 150 - 3 in.	190	24	152.4	4	19					
	ANSI 300 - 3 in.	210	28.5	168.1	8	22					
	ANSI 600 - 3 in.	210	32	168.1	8	22					
	JPI 150 - 3 in.	190	24	152.4	4	19					
	JPI 300 - 3 in.	210	28.5	168.1	8	22					
	JPI 600 - 3 in.	210	32	168.1	8	22					
4 in./100mm	JIS 10K - 100 mm	210	18	175	8	19	157	95±1	23	40	
	JIS 20K - 100 mm	225	24	185	8	23					
	JIS 30K - 100 mm	240	32	195	8	25					
	ANSI 150 - 4 in.	229	24	190.5	8	19					
	ANSI 300 - 4 in.	254	32	200.2	8	22					
	JPI 150 - 4 in.	229	24	190.5	8	19					
JPI 300 - 4 in.	254	32	200.2	8	22						

Note

Note

azbil

Yamatake Corporation
Advanced Automation Company

1-12-2 Kawana, Fujisawa
Kanagawa 251-8522 Japan

URL:<http://www.azbil.com>