

PTG series

Smart Pressure Transmitter

Model PTG71 / PTG72

OVERVIEW

The Smart Pressure Transmitter model PTG is a high-performance, highly reliable gauge pressure transmitter. Based on Yamatake's proven Smart Transmitter technologies, the model PTG offers improved performance and reliability with size, weight and cost advantages. An optional, built-in digital indicator allows the pressure transmitter to be used in a wide variety of applications.

The model PTG can also enable two-way communications between model SFC (Smart Field Communicator), or HART 275 communicator, and, via DE protocol, a TDCS3000 or 3000X and a database, thus facilitating self-diagnosis, range resetting, and automatic zero adjustment operations.



FEATURES

Compact and lightweight

- Approx. 0.9 kg (Screw connection type)

Broad range setting

- Range from -100 kPa to 50 MPa.
- Span from 2.0 kPa to 50 MPa.

Note) Screw connection type. Covered with five ranges.

Remote communication

Any range can be set using the SFC or the HART communicator (available separately). This further increases range flexibility and keeps inventory down.

Built-in digital indicator

The built-in digital indicator option effectively checks output on site.

Type of protection

- Water and dust proof for IEC IP67
- FM Explosionproof for Class I, Division 1, Group A, B, C, and D, T4, ambient temperature = 60°C
- FM Dust-ignition-proof for Class II and III, Division 1, Groups E, F and G, ambient temperature = 60°C, Type 4X
- FM Intrinsically safe approval
Intrinsically safe for Class I, II, III, Division 1, Group A, B, C, D, E, F, G
T4 / Class I, Zone 0, AEx ia IIC T4
- NEPSI Flameproof for Ex d IIC T4, T5, T6
- NEPSI Dust ignition-proof for DIP DP T11

External views of the PTG series



Model PTG_G
(Screw type)



Model PTG_B
(Flush diaphragm type)



Model PTG_F
(Flange type)



Model PTG_S
(Ferrule clamp type)



Model PTG_S
(Ferrule cap nut type)



Model PTG_K
(Ferrule clamp type
with cooling tower)



Model PTG_K
(Ferrule cap nut type
with cooling tower)



Model PTG_T
(Remote seal with ferrule type)



Model PTG_T
(Remote seal with ferrule cap nut type)

COMMON SPECIFICATIONS

Type of protection

JIS C0920 watertight, JIS F8001 class 2 water or equivalent, NEMA 3 and 4X, IEC IP67

FM Explosionproof approval

Explosionproof for Class I, Division 1, Groups A, B, C and D, T4, ambient temperature = 60°C

Dust-ignition for Class II and III, Division 1, Groups E, F and G, T6 ambient temperature = 60°C, Type 4X

FM Intrinsically safe approval

Intrinsically safe for Class I, II, III, Division 1, Group A, B, C, D, E, F, G

T4 / Class I, Zone 0, AEx ia IIC T4

NEPSI Flameproof approval

Ex d IIC T4

Ambient temperature: - 25°C to + 60°C

Temperature of wetted part: - 25°C to +130°C

Ex d IIC T5

Ambient temperature: - 25°C to + 60°C

Temperature of wetted part: - 40°C to + 95°C

Ex d IIC T6

Ambient temperature: - 25°C to + 40°C

Temperature of wetted part: - 40°C to + 80°C

Dust ignition-proof

DIP DP T11

Supply voltage and load resistance

Refer to Figure 1.

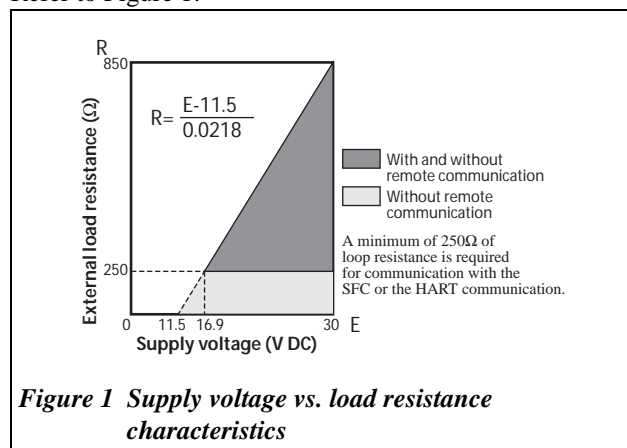

Power supply and voltage effect

0.005% F.S./V

Output / Communication

Model PTG71

Analog output (4 to 20mA DC) / SFC communication

Model PTG72

Analog output (4 to 20mA DC) / HART protocol
DE output / SFC communication

Response speed

Approx. 400 ms

Vibration Tolerance

Less than 100 Hz : 2 G

100 to 2000 Hz : 1 G

Zero adjustment

Internal zero adjustment function

CE conformity

- EN50081-2-1993, Electromagnetic Compatibility- Generic Emission Standard, Part 2: Industrial Environment
- EN50082-2-1995, Electromagnetic Compatibility- Generic Immunity Standard, Part 2: Industrial Environment
- EN61010-1-1993, Safety requirements for electrical equipment, control and laboratory use, Part: General requirement

Finish

Baked acrylic paint, metallic green (Munsell 5G7/8)

Electrical connection

1/2 NPT internal thread

Mounting

- Direct mounting on a pipe (line mount)
- 2-inch pipe mounting
- Wall mounting

When mounting a PTG transmitter, consider its characteristics against vibration and overall vibration including piping.

Use an optional mounting bracket when mounting it onto 2-inch pipe or wall.

Optional specifications

Built-in indicating meter

The digital LCD indicator (optional) displays engineering units and can be set freely between -1999 and 1999 (3.5 digits).

Mounting bracket

Bracket for 2-inch pipe or wall mounting (For thread connection type and ferrule remote sealed type)

Oil free finish

Oil is removed from the wetted parts before shipment.

Oil and water free finish

Oil and water are removed from the wetted parts before shipment.

Electrolytic grinding (For ferrule type only)

The surface of the wetted parts is smoothed by electrolytic grinding.

Passive state finish (For ferrule type only)

The surface of the wetted parts is treated with a passive state finish to form a protective film to increase resistance to corrosion.

Corrosion-resistant finish

Corrosion-proof paint (Baked epoxy paint), fungus-proof finish

Working range of negative pressure

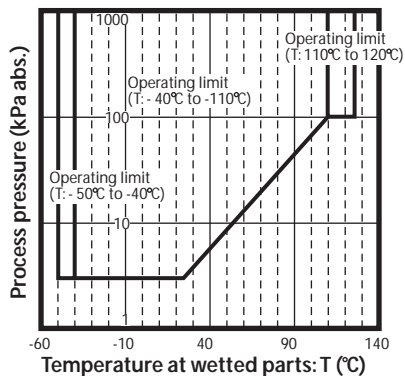

Figure 2 Minimum working pressure for model PTG_G

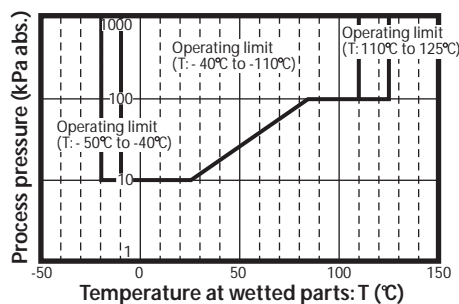
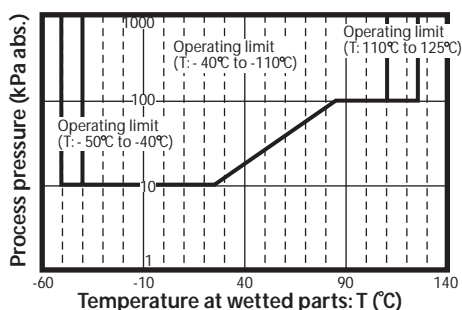
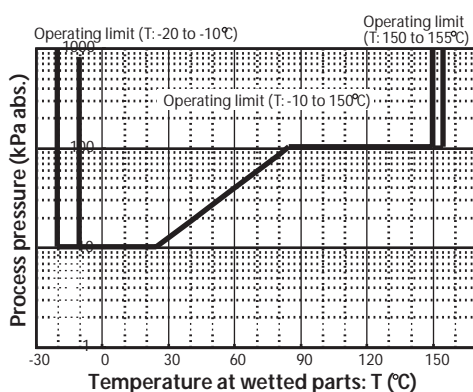

Figure 3 Minimum working pressure for model PTG_S, model PTG_T Minimum working pressure combination of model PTG_F and propylene glycol.



Minimum working pressure for combination of model PTG_B or model PTG_F



Minimum working pressure for model PTG_K

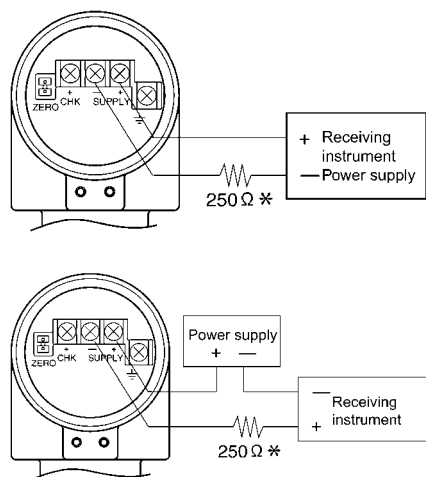

Note) *A minimum of 250 Ω of loop resistance is required for communication with the SFC or the HART Communicator.

Index of detailed specifications for process connection types

Process connection	Process connection style	Measurement span	Reference page
Screw type PTG_G	G3/8 external thread G1/2 external thread Rc3/8 internal thread Rc1/2 internal thread 1/2NPT internal thread M20 × 1.5 external	2.0 to 100 kPa {0.021 to 1.019 kgf/cm ² } 40 to 400 kPa {0.408 to 4.07 kgf/cm ² } 0.2 to 2 MPa {2.04 to 20.3 kgf/cm ² } 1 to 10 MPa {10.20 to 101.9 kgf/cm ² }	6 to 11
	Rc1/4 internal thread G1/2 external thread 1/4NPT internal thread M20 × 1.5 external thread	5 to 50 Mpa {51.0 to 509 kgf/cm ² }	
Flush diaphragm type PTG_B	G2-inch external thread	2.0 to 100 kPa {0.021 to 1.019 kgf/cm ² } 40 to 400 kPa {0.408 to 4.07 kgf/cm ² } 0.2 to 2 MPa {2.04 to 20.3 kgf/cm ² } 1 to 10 MPa {10.20 to 101.9 kgf/cm ² }	12 to 14
	G1/2-inch external thread	0.2 to 2 MPa {2.04 to 20.3 kgf/cm ² } 1 to 10 MPa {10.20 to 101.9 kgf/cm ² }	
Flange type PTG_F	JIS10K 50mm JIS30K 50mm JPI/ANSI150 2 inches JPI/ANSI300 2 inches JPI/ANSI600 2 inches JIS10K 15mm JIS30K 15mm JPI/ANSI150 ½ inch JPI/ANSI300 ½ inch JPI/ANSI600 ½ inch	2.0 to 100 kPa {0.021 to 1.019 kgf/cm ² } 40 to 400 kPa {0.408 to 4.07 kgf/cm ² } 0.2 to 2 MPa {2.04 to 20.3 kgf/cm ² } 1 to 10 MPa {10.20 to 101.9 kgf/cm ² }	15 to 18
Ferrule type (Direct mount) PTG_S	IDF 2S clamp IDF 1½S clamp IDF 1S clamp	2.0 to 100 kPa {0.021 to 1.019 kgf/cm ² } 40 to 400 kPa {0.408 to 4.07 kgf/cm ² } 0.2 to 2 MPa {2.04 to 20.3 kgf/cm ² }	19 to 21
	IDF 2S cap nut IDF 1½S cap nut	2.0 to 100 kPa {0.021 to 1.019 kgf/cm ² } 40 to 400 kPa {0.408 to 4.07 kgf/cm ² } 0.2 to 2 MPa {2.04 to 20.3 kgf/cm ² }	22 to 24
Ferrule type with cool- ing tower PTG_K	IDF 2S clamp IDF 1½S clamp	2.0 to 100 kPa {0.021 to 1.019 kgf/cm ² } 40 to 400 kPa {0.408 to 4.07 kgf/cm ² } 0.2 to 2 MPa {2.04 to 20.3 kgf/cm ² }	25 to 27
	IDF 1S clamp	40 to 400 kPa {0.408 to 4.07 kgf/cm ² } 0.2 to 2 MPa {2.04 to 20.3 kgf/cm ² }	
	IDF 2S cap nut IDF 1½ inch cap nut	2.0 to 100 kPa {0.021 to 1.019 kgf/cm ² } 40 to 400 kPa {0.408 to 4.07 kgf/cm ² } 0.2 to 2 MPa {2.04 to 20.3 kgf/cm ² }	28 to 30
Remote seal with fer- rule type (Capillary 1, 3, 5 m) PTG_T	IDF 2S clamp	2.0 to 100 kPa {0.021 to 1.019 kgf/cm ² } 40 to 400 kPa {0.408 to 4.07 kgf/cm ² } 0.2 to 2 MPa {2.04 to 20.3 kgf/cm ² }	31 to 33
	IDF 1½S clamp	40 to 400 kPa {0.408 to 4.07 kgf/cm ² } 0.2 to 2 MPa {2.04 to 20.3 kgf/cm ² }	
	IDF 2S cap nut	2.0 to 100 kPa {0.021 to 1.019 kgf/cm ² } 40 to 400 kPa {0.408 to 4.07 kgf/cm ² } 0.2 to 2 MPa {2.04 to 20.3 kgf/cm ² }	34 to 36
	IDF 1½S cap nut	40 to 400 kPa {0.408 to 4.07 kgf/cm ² } 0.2 to 2 MPa {2.04 to 20.3 kgf/cm ² }	

Screw type



Model PTG7_G-_7

Accuracy *1	± 0.2% F.S. (50 MPa > X > 10 MPa) ± (0.2 × 10.0 / X)% F.S. (10 MPa > X > 5.0 MPa)
Zero temperature effect per 30°C *1	± (0.4 × 10.0 / X + 0.35)%

Note) *1: Within a range of URV ≥ 0 and LRV ≥ 0

Ambient temperature limits

Normal operating range

-25 to 60°C

Transportation and storage temperature

-40 to 70°C

Temperature range of wetted parts

-40 to 110°C

Ambient humidity limits

5 to 100% RH

Materials

Fill fluid

Silicone oil

Wetted parts

Diaphragm

SUS316L

Others

SUS316

Case

Aluminum alloy

Weight

Approx. 0.9 kg

For other specification, please refer to COMMON SPECIFICATIONS.

Measuring span / Setting range / Max. working pressure

Model no.	Measuring span	Setting Range	Max. Working Pressure	Process Connection
PTG7_G - _3	2.0 to 100 kPa	-100 to 100 kPa	200 kPa	Rc3/8 internal thread, Rc1/2 internal thread, G3/8 external thread, G1/2 external thread, 1/2NPT internal thread, M20X1.5 external thread
PTG7_G - _4	40 to 400 kPa	-100 to 400 kPa	800 kPa	
PTG7_G - _5	0.2 to 2 MPa	-0.1 to 2MPa	4 MPa	
PTG7_G - _6	1 to 10 MPa	-0.1 to 10MPa	20 MPa	
PTG7_G - _7	5 to 50 MPa	-0.1 to 50MPa	75 MPa*	Rc1/4 internal thread G1/2 external thread 1/4NPT internal thread M20 1.5external thread

Note) * 62.5 MPa for explosion-proof type

Accuracy / Temperature effect

Model PTG7_G-_3

Accuracy *1	± 0.2% F.S. (100 kPa > X > 20 kPa) ± (0.2×20 / X)% F.S. (20 kPa > X > 2 kPa)
Zero temperature effect per 30°C *1	± (0.5×40 / X + 0.35)%

Model PTG7_G-_4

Accuracy *1	± 0.2% F.S. (400 kPa > X > 80 kPa) ± (0.2×80 / X)% F.S. (80 kPa > X > 40 kPa)
Zero temperature effect per 30°C *1	± (0.4 × 80 / X + 0.35)%

Model PTG7_G-_5

Accuracy *1	± 0.2% F.S. (2.0 MPa > X > 0.4 MPa) ± (0.2 × 0.4 / X)%F.S. (0.4 MPa > X > 0.2 MPa)
Zero temperature effect per 30°C *1	± (0.4 × 0.4 / X + 0.35)%

Model PTG7_G-_6

Accuracy *1	± 0.2% F.S. (10 MPa > X > 2.0 MPa) ± (0.2 × 2.0/X)%F.S. (2.0 MPa > X > 5.0 MPa)
Zero temperature effect per 30°C *1	± (0.4 × 2.0 / X + 0.35)%

MODEL SELECTION**Smart Pressure Transmitter model PTG7XG**

Process connection: Screw type

Measuring span: 2.0 to 100 kPa, 40 to 400 kPa, 0.2 to 2 MPa, 1 to 10 MPa, 5 to 50 MPa

Model number structure: Basic model number - selection - Option1 - Option2

Basic model number		Selection			Option1	Option2
Product description	Gauge pressure transmitter: Screw connection type with SFC communication	PTG71G				
	Gauge pressure transmitter: Screw connection type with SFC/HART communication	PTG72G				
		-				
Type of protection	Water and dust proof: IEC IP67 Electrical connection: 1/2 NPT	N				
	FM Explosionproof Electrical connection: 1/2 NPT	D				
	FM Intrinsically safe Electrical connection: 1/2 NPT	E				
	NEPSI Flameproof Electrical connection: 1/2 NPT	L				
Measuring span	2.0 to 100 kPa (0.021 to 1.019 kgf/cm ²)	3				
	40 to 400 kPa (0.408 to 4.07 kgf/cm ²)	4				
	0.2 to 2 MPa (2.04 to 20.3 kgf/cm ²)	5				
	1 to 10 MPa (10.20 to 101.9 kgf/cm ²)	6				
	5 to 50 MPa (51.0 to 509 kgf/cm ²)	7				
Material: Diaphragm / wetted parts other than diaphragm / fill fluid	SUS316L/SUS316/Silicone oil		B1			
Process connection	G ¹ / ₂ external thread			G4		
	G ³ / ₈ external thread (Not applicable for measuring span code "7")			G3		
	Rc ¹ / ₄ internal thread (Applicable only for measuring span code "7")			C2		
	Rc ¹ / ₂ internal thread (Not applicable for measuring span code "7")			C4		
	Rc ³ / ₈ internal thread (Not applicable for measuring span code "7")			C3		
	1/4NPT internal thread (Applicable only for measuring span code "7")			N2		
	1/2NPT internal thread (Not applicable for measuring span code "7")			N4		
	M20×1.5 external thread			PH		
Option 1					-	
No option						X
SFC communication DE output (Applicable for model PTG72 only)						8
Built-in digital indicator						M
Heavy-duty corrosion-proof coating						B
Wetted part finish	Oil free finish					G
	Water and oil free finish					H
Option2						-
No option						X
Test report						1
Material certificate						2
Over-pressure leak test						4
Strength calculation sheet (JIS)						5
Traceability certificate						6
Non SI unit						F
Mounting bracket						H
Electrical connection M20 × 1.5 adapter						T

DIMENSIONS

[mm]

Materials of construction

KEY No.	Description	Materials
1	Case	Aluminum alloy
2	Body	SUS 316 (Diaphragm SUS 316L)
3	Joint	SUS 316

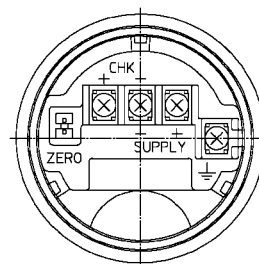

Terminal Connection
(M4 Screw)

See Table 3

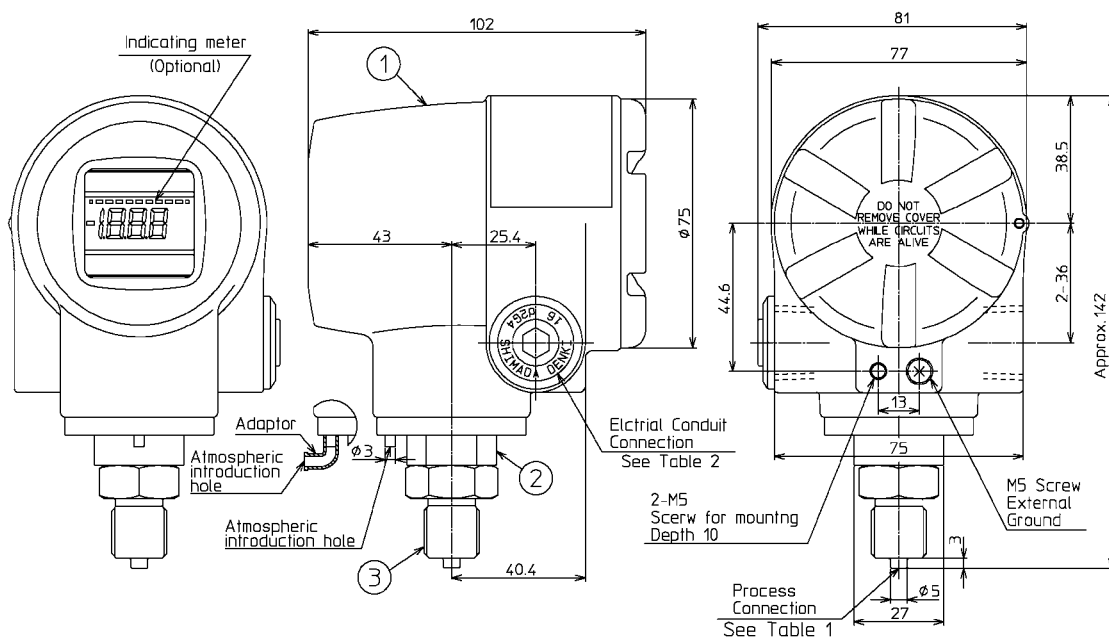

Table1 (See Inst. spec.)

Mode No.	Thread Type	Thread Size	Process Connection
G	G	3	G3/8 External

Table2 (See Inst. spec.)

Mode No.	Electrical Conduit Connection
A·B	G 1/2 Internal
	1/2NPT Internal
N·D·L	M20 Internal (1 pc)
	M20 Internal (2 pcs)

Table3 Terminal

Symbol	Terminal
SUPPLY +, SUPPLY -	Power supply and output signal
CHK+, CHK-	Check meter
⊥	Ground
ZERO	ZERO Adjuster

Process connection : G3/8 External

[mm]

Materials of construction

KEY No.	Description	Materials
1	Case	Aluminum alloy
2	Body	SUS 316 (Diaphragm SUS 316L)
3	Joint	SUS 316

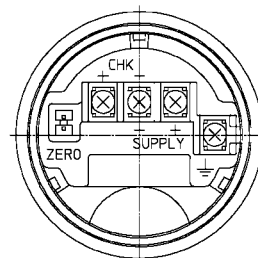

Terminal Connection
(M2 Screw)

See Table 3

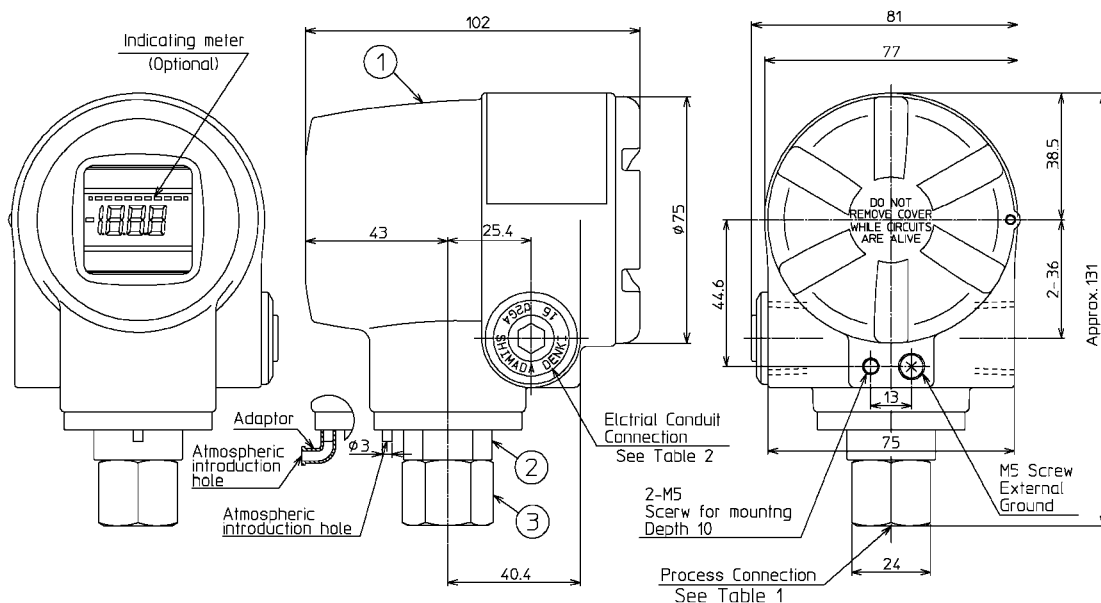

Table1 (See Inst. spec.)

Mode No.	Thread Type	Thread Size	Thread Type of Process Connection
C	3	Rc3/8	Internal

Table2 (See Inst. spec.)

Mode No.	Selection	Optional2	Electrical Conduit Connection
A·B	—	G 1/2	Internal
	—	1/2NPT	Internal
N·D·L	T	M20	Internal (1 pc)
	U	M20	Internal (2 pcs)

Table3 Terminal

Symbol	Terminal
SUPPLY +, SUPPLY -	Power supply and output signa.
CHK+, CHK-	Check meter
⏏	Ground
ZERO	ZERO Adjuster

Process connection : Rc3/8 Internal

[mm]

Materials of construction

KEY No.	Description	Materials
1	Case	Aluminum alloy
2	Body	SUS 316 (Diaphragm SUS 316L)

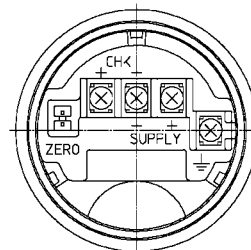

Terminal Connection
(M4 Screw)

See Table 3

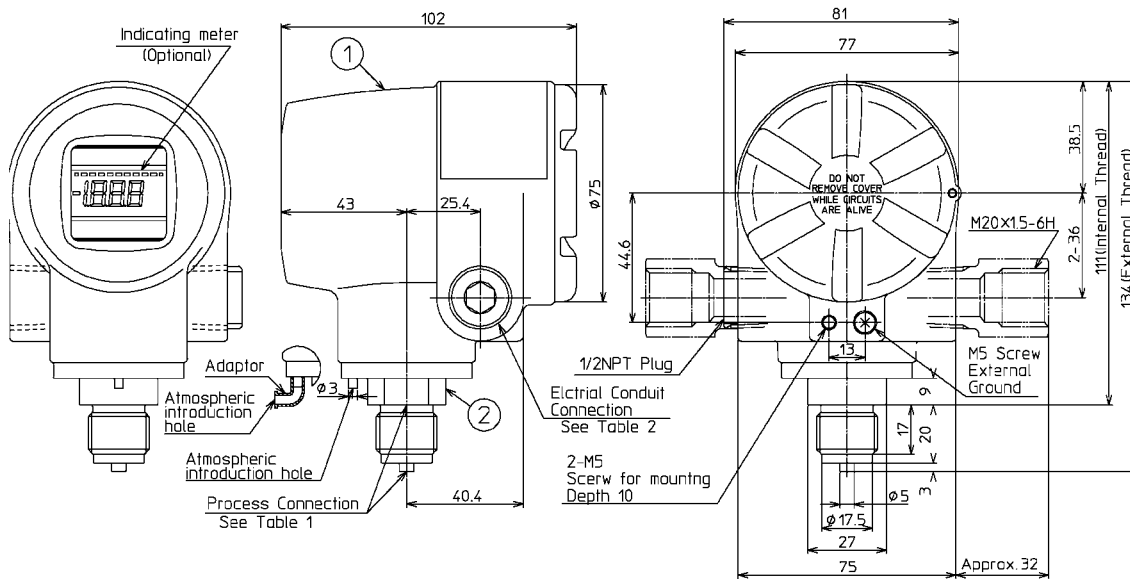

Table1 (See Inst. spec.)

Mode No.	Thread Type of Process Connection
G	4 G1/2 External
N	4 NPT 1/2 Internal
C	4 Rc 1/2 Internal

Table2 (See Inst. spec.)

Mode No.	Electrical Conduit Connection
—	1/2NPT Internal
N. D. L	T M20 Internal (1 pc)
	U M20 Internal (2 pcs)

Table3 Terminal

Symbol	Terminal
SUPPLY +, SUPPLY -	Power supply and output signal
CHK+, CHK-	Check meter
⏏	Ground
ZERO	ZERO Adjuster

Process connection :G1/2 External
 :1/2NPT internal
 :M20x1.5 External

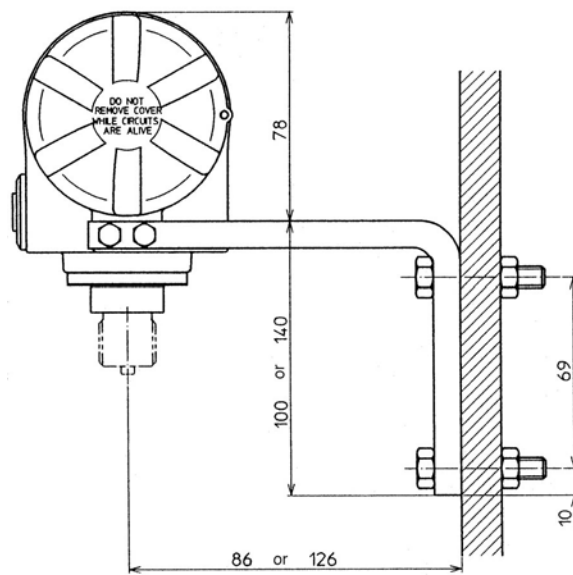
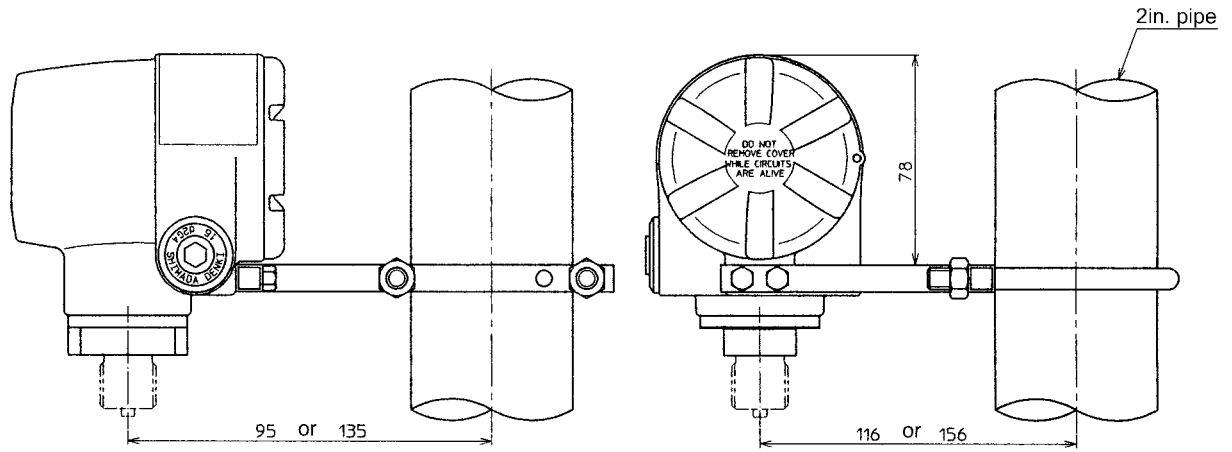

Flush diaphragm type

(G2 inch external, G1/2 inch external / flush diaphragm)



Measuring span / Setting range / Max. working pressure

Model Number	Measuring span	Setting Range	Max. Working Pressure	Process Connection
PTG7_B - _3	2.0 to 100kPa	-100 to 100kPa	200kPa	G2 external thread
PTG7_B - _4	40 to 400kPa	-100 to 400kPa	800kPa	
PTG7_B - _5	0.2 to 2MPa	-0.1 to 2MPa	4MPa	G2 external thread
PTG7_B - _6	1 to 10MPa	-0.1 to 10MPa	20MPa	G1/2 external thread

Accuracy / Temperature effect

Model PTG7_B- _3

Accuracy *1	± 0.5% F.S. (100 kPa ≥ X ≥ 20 kPa) ± (0.5 × 20 / X)% F.S. (20k Pa ≥ X ≥ 2.0 kPa)	
-------------	---	--

Zero temperature effect per 30°C *1	G2 external thread	± (4.7×40 / X +0.35)%
-------------------------------------	--------------------	-----------------------

Model PTG7_B- _4

Accuracy *1	± 0.5% F.S. (400 kPa ≥ X ≥ 80 kPa) ± (0.5 × 80 / X)% F.S. (80 kPa ≥ X ≥ 40 kPa)	
-------------	--	--

Zero temperature effect per 30°C *1	G2 external thread	± (2.5 × 80 / X +0.35)%
-------------------------------------	--------------------	-------------------------

Model PTG7_B- _5

Accuracy *1	± 0.5% F.S. (2 MPa ≥ X ≥ 0.4 MPa) ± (0.5 × 0.4 / X)% F.S. (0.4 MPa ≥ X ≥ 0.2 MPa)	
-------------	--	--

Zero temperature effect per 30°C *1	G2 external thread	± (0.82 × 0.4 / X +0.35)%
	G1/2 external thread	± (10.8 × 0.4 / X +0.35)%

Model PTG7_B- _6

Accuracy *1	± 0.5% F.S. (10.0 MPa ≥ X ≥ 2.0 MPa) ± (0.5 × 2.0 / X)% F.S. (2.0 MPa ≥ X ≥ 1.0 MPa)	
-------------	---	--

Zero temperature effect per 30°C *1	G2 external thread	± (0.49 × 2.0 / X +0.35)%
	G1/2 external thread	± (2.48 × 2.0 / X +0.35)%

Note) *1: Within a range of URV ≥ 0 and LRV ≥ 0

Ambient temperature limits

Normal operating ranges

Fill fluid	G2 external thread	G1/2 external thread
Silicone oil	-20 to 60°C	-10 to 50°C
Propylene glycol	-10 to 60°C	-10 to 50°C

Transportation and storage temperatures

Fill fluid	G2 external thread	G1/2 external thread
Silicone oil	-30 to 60°C	20 to 60°C
Propylene glycol	-20 to 60°C	-20 to 60°C

Temperature ranges of wetted parts

Fill fluid	G2 external thread	G1/2 external thread
Silicone oil	-20 to 110°C	-10 to 85°C
Propylene glycol	-10 to 110°C	-10 to 85°C

Ambient humidity limits

5 to 100% RH

Materials

Fill fluid

- Silicone oil
- Propylene glycol

Wetted parts

Diaphragm
SUS316L

Others
SUS316

Case

Aluminum alloy

Weight

- G2 inch external thread: Approx. 2.5kg
- G1/2 inch external thread: Approx. 1.5kg

Process connection

- G2 inch external thread
- G1/2 inch external thread

MODEL SELECTION**Smart pressure transmitter model PTG7XB**

Process connection: Flush diaphragm type (G2 inch external, G1/2 inch external / flush diaphragm)

Measuring span: 2.0 to 100 kPa, 40 to 400 kPa, 0.2 to 2 MPa, 1 to 10 MPa

Basic model number		Selection				Option1	Option2
		-				-	
Product description	Gauge pressure transmitter: Screw connection type (flush) with SFC Communication	PTG71B					
	Gauge pressure transmitter: Screw connection type (flush) with SFC / HART communication	PTG72B					
		-					
Type of protection	Water and dust proof: IEC IP67 Electrical connection: 1/2NPT	N					
	FM Explosionproof Electrical connection: 1/2NPT	D					
	FM Intrinsically safe Electrical connection: 1/2 NPT	E					
	NEPSI Flameproof Electrical connection: 1/2NPT	L					
Measuring span	2.0 to 100 kPa (0.021 to 1.019 kgf/cm ²) (Not applicable for process connection G1/2)	3					
	40 to 400 kPa (0.408 to 4.07 kgf/cm ²) (Not applicable for process connection G1/2)	4					
	0.2 to 2MPa (2.04 to 20.3 kgf/cm ²)	5					
	1 to 10MPa (10.20 to 101.9 kgf/cm ²)	6					
Material: Diaphragm / wetted parts other than diaphragm /fill fluid	SUS316L/SUS316L/Silicone oil	C1					
	SUS316L/SUS316L/Propylene glycol	CB					
Process connection	G2 external thread				AGF		
	G½ external thread				AG4		
Option 1						-	
No option							X
SFC communication DE output (Applicable only for model PTG72)							8
Built-in digital indicator							M
Heavy-duty corrosion-proof coating							B
Wetted part finish	Oil free finish						G
	Water and oil free finish						H
Option2						-	
No option							X
Test report							1
Material certificate							2
Over-pressure leak test							4
Strength calculation sheet (JIS)							5
Traceability certificate							6
Non SI unit							F
Mounting bracket							H
Electrical connection: M20 × 1.5 adapter							T

DIMENSIONS

[mm]

Materials of construction

KEY No.	Description	Materials
1	Case	Aluminum alloy
2	Body	SUS 316 (Diaphragm SUS 316L)
3	Wetted Part	SUS 316L

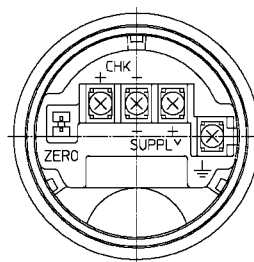

Terminal Connection
(M4 Screw)
See Table 3

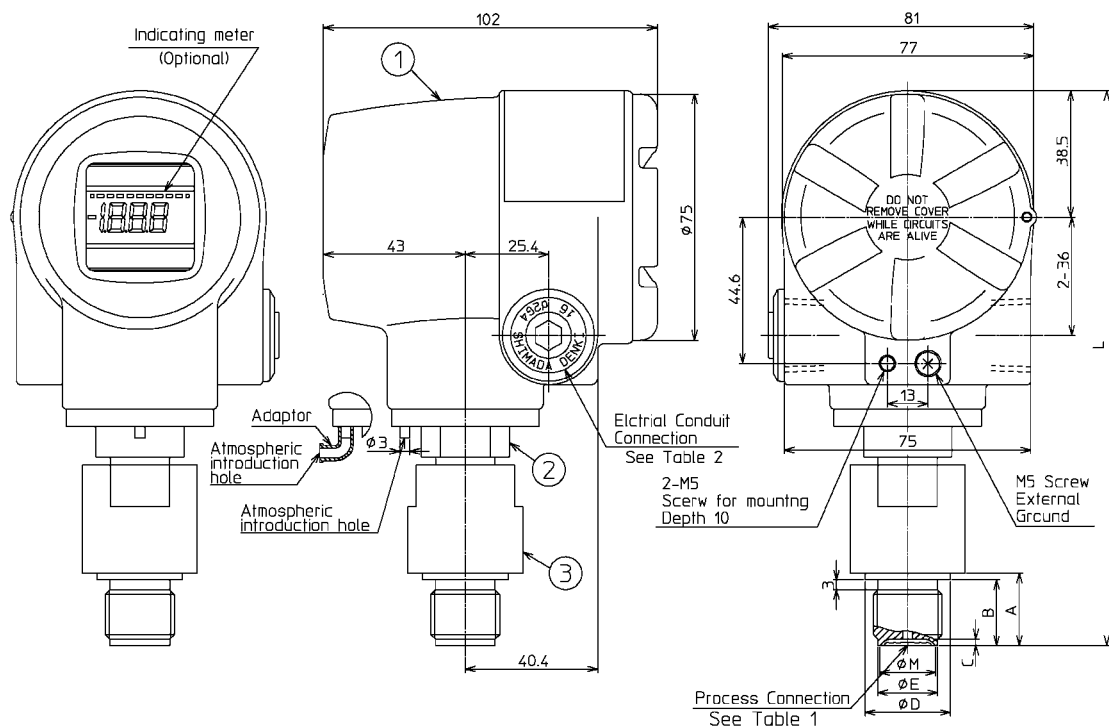

Table1 (See Inst. spec.)

Fitting	Mode No.		Thread Type of Process Connection (G)	A	B	φD	C	φE	φM	L
	Thread Type	Thread Size								
A	G	4	G 1/2 External	22	20	26	2	18.2	17	Approx 172
		F	G 2 External	30	-	-	-	-	43	Approx 180

Table2 (See Inst. spec.)

Mode No.	Electrical Conduit Connection
A, B	G 1/2 Internal
N, D, L	1/2NPT Internal

Table3 Terminal

Symbol	Terminal
SUPPLY +, SUPPLY -	Power supply and output signal
CHK+, CHK-	Check meter
⏏	Ground
ZERO	ZERO Adjuster

Flange type

(1/2 inch, 2 inches)

**Measuring Span / Setting Range / Max. Working Pressure**

Model Number	Measuring span	Setting Range	Max. Working Pressure	Process Connection
PTG7_F - _3	2.0 to 100 kPa	-100 to 100 kPa	200kPa	2 inches (50 mm), 1/2 inch (15 mm)
PTG7_F - _4	40 to 400 kPa	-100 to 400 kPa	800kPa	
PTG7_F - _5	0.2 to 2 MPa	-0.1 to 2 MPa	4MPa or flange rating	
PTG7_F - _6	1 to 10 MPa	-0.1 to 10 MPa	20MPa or flange rating	

Accuracy / Temperature effect**Model PTG7_F - _3**

Accuracy *1	$\pm 0.5\%$ F.S. ($100 \text{ kPa} \geq X \geq 20 \text{ kPa}$) $\pm (0.5 \times 2.0 / X)\%$ F.S. ($20 \text{ kPa} > X > 2 \text{ kPa}$)
-------------	---

Zero temperature effect per 30°C *1	2 inches (50 mm)	$\pm (4.5 \times 40 / X + 0.35)\%$
	1/2 inch (15 mm)	$\pm (10.0 \times 40 / X + 0.35)\%$

Model PTG7_F - _4

Accuracy *1	$\pm 0.5\%$ F.S. ($400 \text{ kPa} \geq X \geq 80 \text{ kPa}$) $\pm (0.5 \times 80 / X)\%$ F.S. ($80 \text{ kPa} \geq X \geq 40 \text{ kPa}$)
-------------	---

Zero temperature effect per 30°C *1	2 inches (50 mm)	$\pm (2.4 \times 80 / X + 0.35)\%$
	1/2 inch (15 mm)	$\pm (7.1 \times 80 / X + 0.35)\%$

Model PTG7_F - _5

Accuracy *1	$\pm 0.5\%$ F.S. ($2 \text{ MPa} \geq X \geq 0.4 \text{ MPa}$) $\pm (0.5 \times 0.4 / X)\%$ F.S. ($0.4 \text{ MPa} \geq X \geq 0.2 \text{ MPa}$)
-------------	---

Zero temperature effect per 30°C *1	2 inches (50 mm)	$\pm (0.8 \times 0.4 / X + 0.35)\%$
	1/2 inch (15 mm)	$\pm (1.4 \times 0.4 / X + 0.35)\%$

Model PTG7_F - _6

Accuracy *1	$\pm 0.5\%$ F.S. ($10.0 \text{ MPa} > X > 2.0 \text{ MPa}$) $\pm (0.5 \times 2.0 / X)\%$ F.S. ($2.0 \text{ MPa} > X > 1.0 \text{ MPa}$)
-------------	--

Zero temperature effect per 30°C *1	2 inches (50 mm)	$\pm (0.5 \times 2.0 / X + 0.35)\%$
	1/2 inch (15 mm)	$\pm (0.5 \times 2.0 / X + 0.35)\%$

(Note) *1: Within a range of URV ≥ 0 and LRV ≥ 0 **Ambient temperature limits****Normal operating range**

Silicone oil -25 to 60°C

Propylene glycol -10 to 60°C

Transportation and storage temperature

Silicone oil -40 to 70°C

Propylene glycol -20 to 60°C

Temperature ranges of wetted parts

Silicone oil -40 to 110°C

Propylene glycol -10 to 110°C

150°C for 30 minutes during steam cleaning.

Ambient humidity limits

5 to 100% RH

Materials**Fill fluid**

- Silicone oil
- Propylene glycol

Wetted parts**Diaphragm**

SUS316L

Others

SUS316

Flange parts

SUS316L

SUS304 (JIS10K)

Case

Aluminum alloy

Weight

ANSI 150, 2 inches type: Approx. 4.2 kg

ANSI 150, 1/2 inch type: Approx. 2 kg

Process connection

- JIS10K 15 mm, 50 mm
- JIS30K 15 mm, 50 mm
- JPI/ ANSI 150 1/2 inch, 2 inches
- JPI/ ANSI 300 1/2 inch, 2 inches
- JPI/ ANSI 600 1/2 inch, 2 inches

MODEL SELECTION

Smart pressure transmitter model PTG7XF

Process connection: Flange type

Measuring span: 2.0 to 100 kPa, 40 to 400 kPa, 0.2 to 2 MPa, 1 to 10 MPa

Model number structure: Basic model number - Selection - Option1 - Option2

Basic model number		Selection						Option1	Option2
Product description	Gauge pressure transmitter: Flange mount type with SFC communication	PTG71F							
	Gauge pressure transmitter: Flange mount type with SFC/ HART communication	PTG72F							
Type of protection	Water and dust proof: IEC IP67 Electrical connection:1/2NPT	N							
	FM Explosionproof Electrical connection:1/2NPT	D							
	FM Intrinsically safe Electrical connection: 1/2 NPT	E							
	NEPSI Flameproof Electrical connection:1/2NPT	L							
Measuring span	2.0 to 100 kPa (0.021 to 1.019 kgf/cm ²)	3							
	40 to 400 kPa (0.408 to 4.07 kgf/cm ²)	4							
	0.2 to 2MPa (2.04 to 20.3 kgf/cm ²)	5							
	1 to 10MPa (10.20 to 101.9 kgf/cm ²)	6							
Material Diaphragm / wetted parts other than dia- phragm/fill fluid	SUS316L/SUS316L/Silicone oil	C1							
	SUS316L/SUS316L/Propylene glycol	CB							
Flange standard/rating	JIS10K	A							
	JIS30K	D							
	ANSI150	G							
	ANSI300	H							
	ANSI600	J							
	JPI150	N							
	JPI300	P							
	JPI600	Q							
Flange diameter	2 inches / 50mm	3							
	1/2 inch / 15mm	7							
Flange material	SUS316L				B				
Flange extension	None					X			
Option 1								-	
No option								X	
SFC communication DE output (Applicable only for model PTG72)								8	
Built-in digital indicator								M	
Heavy-duty corrosion-proof coating								B	
Wetted parts finish	Oil free finish							G	
	Water and oil free finish							H	
Option2								-	
No option								X	
Test report								1	
Material certificate								2	
Over-pressure leak test								4	
Strength calculation sheet (JIS)								5	
Traceability certificate								6	
Non SI unit								F	
Electrical connection:M20 × 1.5 adapter								T	

DIMENSIONS

[mm]

Materials of construction

KEY No.	Description	Materials
1	Case	Aluminum alloy
2	Body	SUS 316
3	Wetted Part	SUS 316L

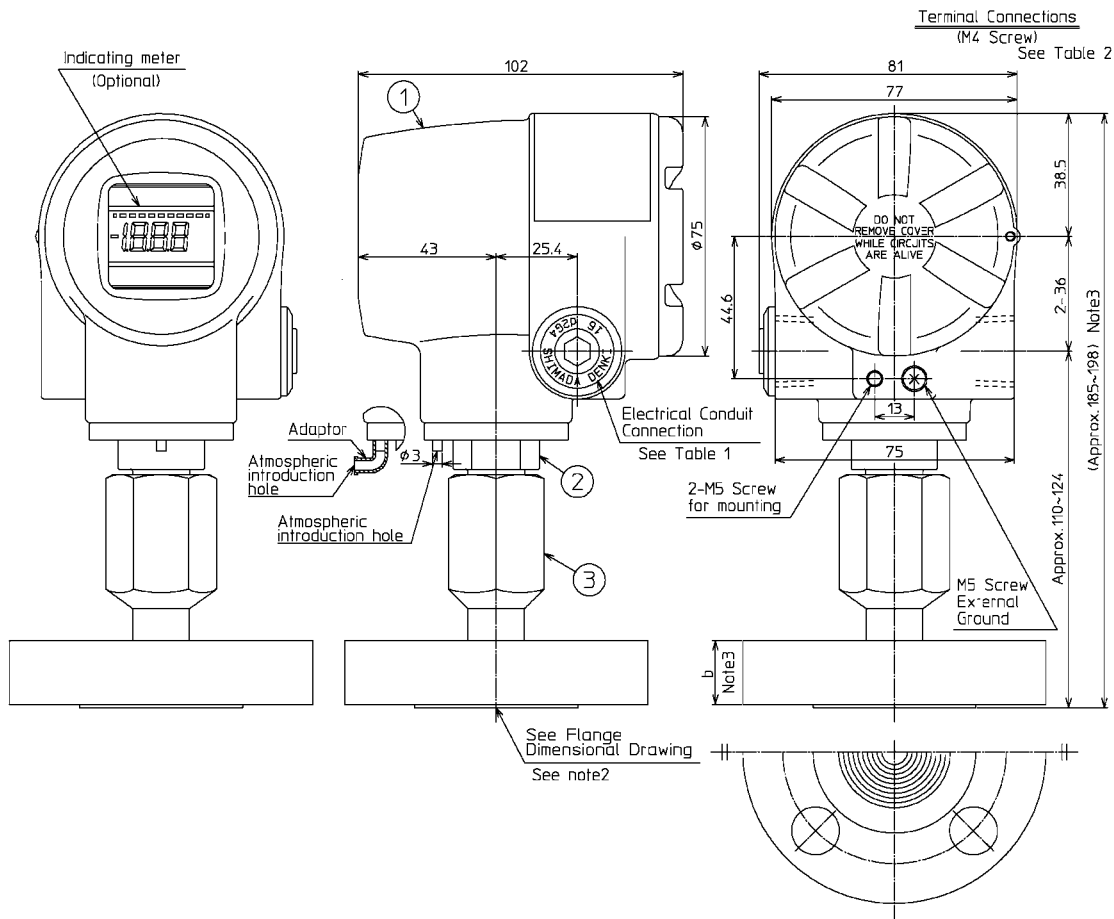
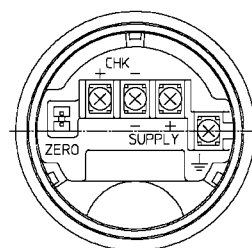

Table1 (See Inst. spec.)

Model No.	Electrical Conduit Connection
A, B	G 1/2 Internal
N, D, L	1/2 NPT Internal

Table2 Terminal

Symbol	Terminal
SUPPLY +, SUPPLY -	Power supply and output signal
CHK +, CHK -	Check meter
⊥	Ground
ZERO	ZERO Adjuster

- Note) 1. See Table 1.
 2. See flange dimensions on proceeding pages.
 3. See flange dimensions on proceeding pages.
 4. Do not loosen. Loosening the flange can cause fill fluid leakage.

JIS 10K - 15 mm / 25 mm

JIS 10K - 50 mm

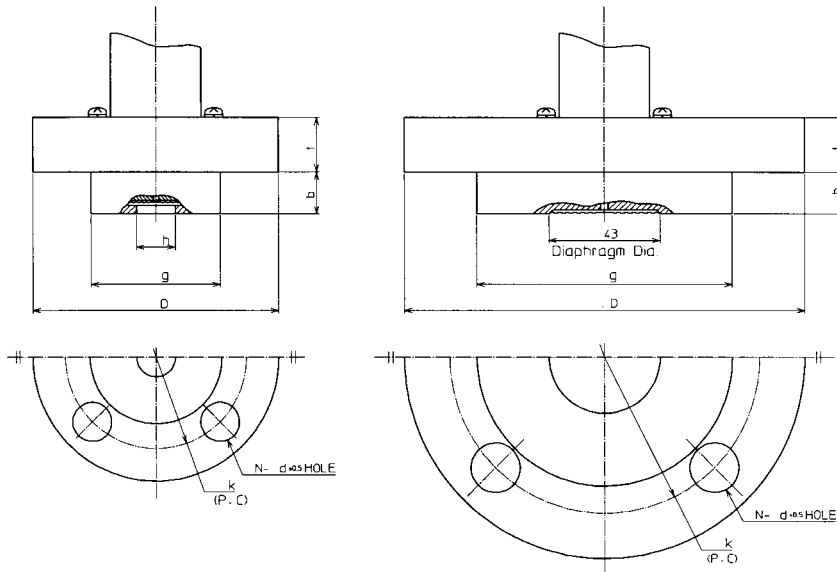

Flange rating	D_0^{-1}	g	k	N	$d_{\pm 0.5}$	1^{+1}	h	b
JIS 10K - 15 mm	95	54	70	4	15	12	15	16
JIS 10K - 50 mm	155	99	120	4	19	16	-	19

JIS 30K - 50mm, ANSI/ JPI - 2 inches

JIS 30K - 15 mm, ANSI/ JPI - 1/2 inch

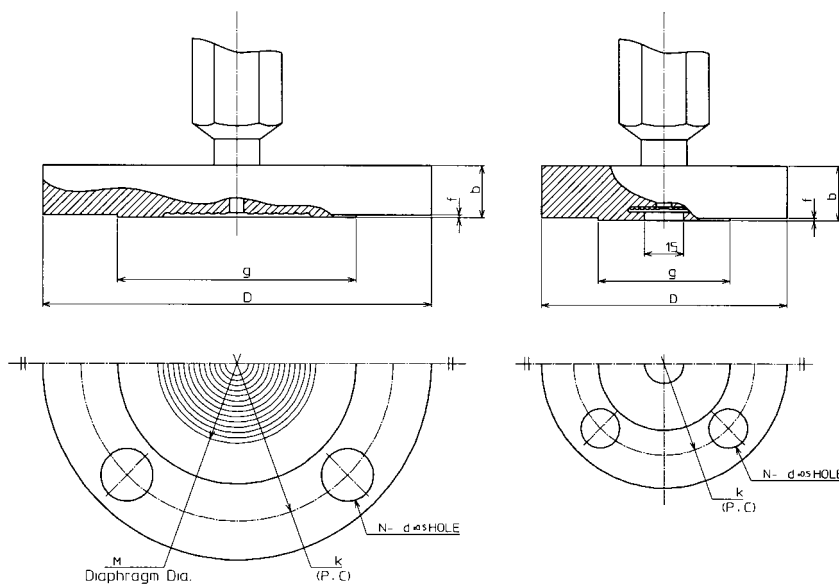

Flange rating	D^{-1}	g	k	N	$d_{\pm 0.5}$	M	b^{+1}	f
JIS 30K - 15 mm	115	55	80	4	19	-	21	1
ANSI/JPI 150 - 1/2 inch	90	35	60.5	4	16	-	22	2
ANSI/JPI 300 - 1/2 inch	95	35	66.5	4	16	-	22	2
ANSI/JPI 600 - 1/2 inch	95	35	66.5	4	16	-	27	7
JIS 30K - 50 mm	165	105	130	8	19	59	22	2
ANSI/JPI 150 - 2 inches	150	92	120.5	4	20	59	20	2
ANSI/JPI 300 - 2 inches	165	92	127	8	20	59	22.5	2
ANSI/JPI 600 - 2 inches	165	92	127	8	20	59	32.5	7

Ferrule type

(1S, 1½S, 2S clamp type)

**Measuring span / Setting range / Max. working pressure**

Model Number	Measuring span	Setting Range	Max. Working Pressure	Process Connection
PTG7_S - _3	2.0 to 100 kPa	-100 to 100 kPa	200 kPa	2S, 1½S
PTG7_S - _4	40 to 400 kPa	-100 to 400 kPa	800 kPa or clamp rating	2S, 1½S, 1S
PTG7_S - _5	0.2 to 2 MPa	-0.1 to 2 MPa	4 MPa or clamp rating	

Accuracy / Max. working pressure**Model PTG7_ S- _3**

Accuracy *1	± 0.5% F.S. (100 kPa ≥ X ≥ 20 kPa) ± (0.5 × 20 / X)% F.S. (20 kPa ≥ X ≥ 2 kPa)	
Zero temperature effect per 30°C *1	2S (Clamp type)	± (2.4 × 40 / X + 0.35)%
	1½S (Clamp type)	± (5.7 × 40 / X + 0.35)%

Model PTG7_ S- _4

Accuracy *1	± 0.5% F.S. (400 kPa ≥ X ≥ 80 kPa) ± (0.5 × 80 / X)% F.S. (80 kPa ≥ X ≥ 40 kPa)	
Zero temperature effect per 30°C *1	2S (Clamp type)	± (1.3 × 80 / X + 0.35)%
	1½S (Clamp type)	± (3.0 × 80 / X + 0.35)%
	1S (Clamp type)	± (30.4 × 80 / X + 0.35)%

Model PTG7_ S- _5

Accuracy *1	± 0.5% F.S. (2 MPa ≥ X ≥ 0.4 MPa) ± (0.5 × 0.4 / X)% F.S. (0.4 MPa ≥ X ≥ 0.2 MPa)	
Zero temperature effect per 30°C *1	2S (Clamp type)	± (0.58 × 0.4 / X + 0.35)%
	1½S (Clamp type)	± (0.92 × 0.4 / X + 0.35)%
	1S (Clamp type)	± (6.4 × 0.4 / X + 0.35)%

Note) *1: Within a range of URV ≥ 0 and LRV ≥ 0

Ambient temperature limits**Normal operating range**

-10 to 60°C

Transportation and storage temperature

-20 to 70°C

Temperature ranges of wetted parts

-10 to 121°C

150°C for 30 minutes during steam cleaning

Ambient humidity limits

5 to 100% RH

Materials**Fill fluid**

Propylene glycol

Wetted parts**Diaphragm**

SUS316L

Others

SUS316

Case

Aluminum alloy

Weight

Approx 1.2 kg

Process connection

- IDF 1S clamp type
- IDF 1½S clamp type
- IDF 2S clamp type

MODEL SELECTION

Smart pressure transmitter model PTG7XS

Process connection: Ferrule clamp type

Measuring span: 2.0 to 100 kPa, 40 to 400 kPa, 0.2 to 2 MPa

Model number structure: Basic model number - Selection - Option1 - Option2

Basic model number		Selection				Option1	Option2
Product description	Gauge pressure transmitter: Ferrule type with SFC communi- cation	PTG71S					
	Gauge pressure transmitter: Ferrule type with SFC/HART communication	PTG72S					
		-					
Type of protection	Water and dust proof: IEC IP67 Electrical connection:1/2NPT	N					
	FM Explosionproof Electrical connection:1/2NPT	D					
	FM Intrinsically safe Electrical connection: 1/2 NPT	E					
	NEPSI Flameproof Electrical connection:1/2NPT	L					
Measuring span	2.0 to 100 kPa (0.021 to 1.1019 kgf/cm ²) (Not applicable for process connection 1S.)	3					
	40 to 400 kPa (0.408 to 4.07 kgf/cm ²)	4					
	0.2 to 2MPa (2.04 to 20.3 kgf/cm ²)	5					
Material: Diaphragm / wetted parts other than dia- phragm/fill fluid	SUS316L/ SUS316L/ Propylene glycol		CB				
Process connection	IDF 1S ferrule clamp type			AH2X			
	IDF 1½S ferrule clamp type			AH3X			
	IDF 2S ferrule clamp type			AH4X			
Option 1						-	
No option						X	
SFC communication DE output (Applicable only for model PTG72)						8	
Built-in digital indicator						M	
Heavy-duty corrosion-proof coating						B	
Wetted parts finish	Oil free finish					G	
	Water and oil free finish					H	
	Electrolytic grinding					K	
	Passive state finish					W	
Option2						-	
No option							X
Test report							1
Material certificate							2
Over-pressure leak test							4
Strength calculation sheet (JIS)							5
Traceability certificate							6
Non SI unit							F
Mounting bracket							H
Electrical connection: M20 × 1.5 adapter							T

DIMENSIONS

[Unit: mm]

Materials of construction

KEY No.	Description	Materials
1	Case	Aluminum alloy
2	Body	SUS 316
3	Ferrule	SUS 316L (Diaphragm SUS 316L)

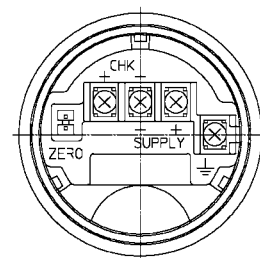

Terminal Connections
(M4 Screw)
See Table 3

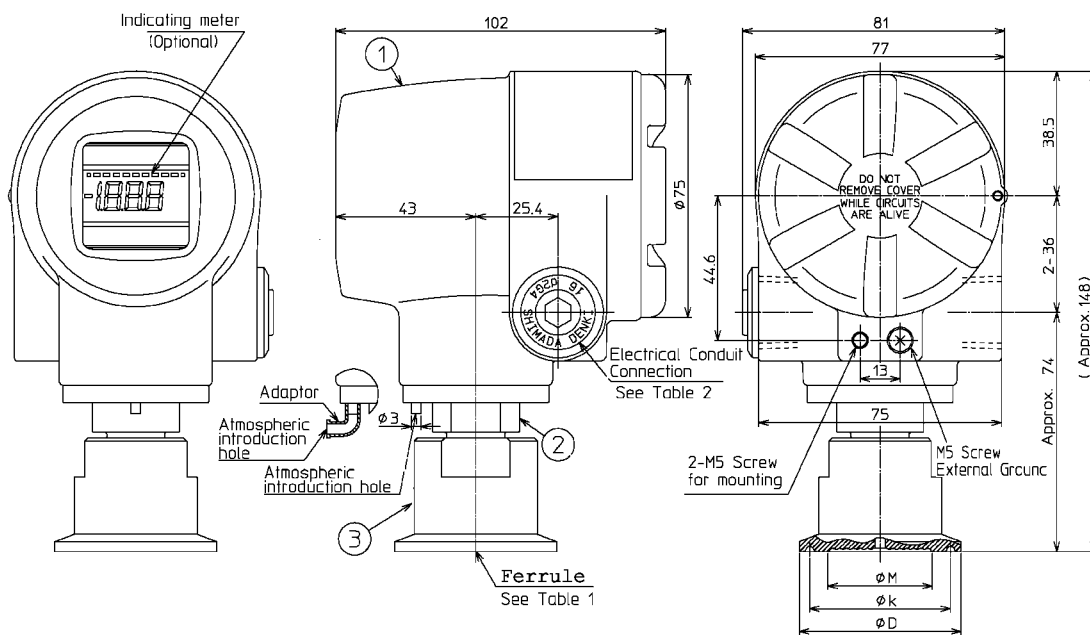

Table1 (See Inst. spec.)

Rating	Fitting	Model No.		D	φk	φM
		Size	Ferrule size			
A	H	2	IDF 1S	50.5	43.5	22
		3	IDF 1.5S			28
		4	IDF 2S			43

Table2 (See Inst. spec.)

Model No.	Electrical Conduit Connection
A, B	G 1/2 Internal
N, D, L	1/2 NPT Internal

Table3 Terminal

Symbol	Terminal
SUPPLY +, SUPPLY -	Power supply and output signal
CHK+, CHK-	Check meter
⊥	Ground
ZERO	ZERO Adjuster

Ferrule type

(1½ inch, 2 inches cap nut type)



Measuring Span / Setting Range / Max. Working Pressure

Model Number	Measuring span	Setting Range	Max. Working Pressure	Process Connection
PTG7_S - _3	2.0 to 100 kPa	-100 to 100 kPa	200 kPa	2S, 1½S
PTG7_S - _4	40 to 400 kPa	-100 to 400 kPa	800 kPa or cap nut rating	
PTG7_S - _5	0.2 to 2 MPa	-0.1 to 2 MPa	4 MPa or cap nut rating	

Accuracy / Max. working pressure

Model PTG7_S- _3

Accuracy *1	± 0.5% F.S. (100 kPa ≥ X ≥ 20 kPa) ± (0.5 × 20 / X)% F.S. (20 kPa ≥ X ≥ 2 kPa)
--------------------	---

Zero temperature effect per 30°C *1	2S (Cap nut type)	± (2.4 × 40 / X + 0.35)%
	1½S (Cap nut type)	± (5.7 × 40 / X + 0.35)%

Model PTG7_S- _4

Accuracy *1	± 0.5% F.S. (400 kPa ≥ X ≥ 80k Pa) ± (0.5 × 80 / X)%F.S. (80 kPa ≥ X ≥ 40 kPa)
--------------------	---

Zero temperature effect per 30°C *1	2S (Cap nut type)	± (1.3 × 80 / X + 0.35)%
	1½S (Cap nut type)	± (3.0 × 80 / X + 0.35)%

Model PTG7_S- _5

Accuracy *1	± 0.5% F.S. (2 MPa ≥ X ≥ 0.4 MPa) ± (0.5 × 0.4 / X)% F.S. (0.4 MPa ≥ X ≥ 0.2M Pa)
--------------------	--

Zero temperature effect per 30°C *1	2S (Cap nut type)	± (0.58 × 0.4 / X + 0.35)%
	1½S (Cap nut type)	± (0.92 × 0.4 / X + 0.35)%

Note) *1: Within a range of URV ≥ 0 and LRV ≥ 0

Ambient temperature limits

Normal operating range

-10 to 60°C

Transportation and storage temperature

-20 to 70°C

Temperature range of wetted parts

-10 to 121°C

150°C within 30 minutes of steam cleaning

Ambient humidity limits

5 to 100% RH

Materials

Fill fluid

Propylene glycol

Wetted parts

Diaphragm

SUS316L

Others

SUS316

Case

Aluminum alloy

Weight

- 1½ inch : Approx. 1.4 kg
- 2 inches : Approx. 1.7 kg

Process connection

- IDF 1½S cap nut type
- IDF 2S cap nut type

MODEL SELECTION**Smart pressure transmitter model PTG7XS**

Process connection: Ferrule cap nut type

Measuring span: 2.0 to 100 kPa, 40 to 400 kPa, 0.2 to 2 MPa

Model number structure: Basic model number - Selection - Option1 - Option2

			Selection					Option1	Option2
Product Description	Gauge pressure transmitter: Ferrule type with SFC communication	PTG71S							
	Gauge pressure transmitter: Ferrule type with SFC/ HART communication	PTG72S							
		-							
Type of protection	Water and dust proof: IEC IP67 Electrical connection: 1/2NPT		N						
	FM Explosionproof Electrical connection: 1/2NPT		D						
	FM Intrinsically safe Electrical connection: 1/2 NPT		E						
	NEPSI Flameproof Electrical connection: 1/2NPT		L						
Measuring span	2.0 to 100 kPa (0.021 to 1.1019 kgf/cm ²)			3					
	40 to 400 kPa (0.408 to 4.07 kgf/cm ²)			4					
	0.2 to 2MPa (2.04 to 20.3 kgf/cm ²)			5					
Material: Diaphragm / wetted parts other than diaphragm/fill fluid	SUS316L/SUS316L/Propylene glycol				CB				
Process connection	IDF1½S ferrule cap nut type					AC3X			
	IDF 2S ferrule cap nut type					AC4X			
Option 1							-		
No option								X	
SFC communication DE output (Applicable only for model PTG72)								8	
Built-in digital indicator								M	
Heavy-duty corrosion-proof coating								B	
Wetted part finish	Oil free finish							G	
	Water and oil free finish							H	
	Electrolytic grinding							K	
	Passive state finish							W	
Option2									-
No option									X
Test report									1
Material certificate									2
Over-pressure leak test									4
Strength calculation sheet (JIS)									5
Traceability certificate									6
Non SI unit									F
Mounting bracket									H
Electrical connection: M20 × 1.5 adapter									T

DIMENSIONS

[Unit: mm]

Materials of construction

KEY No.	Description	Materials
1	Case	Aluminum alloy
2	Body	SUS 316
3	Wetted Part	SUS 316L

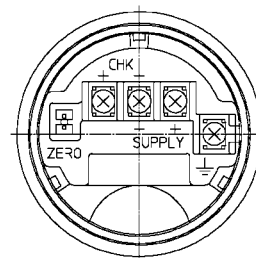

Terminal Connections
(M4 Screw)
See Table 3

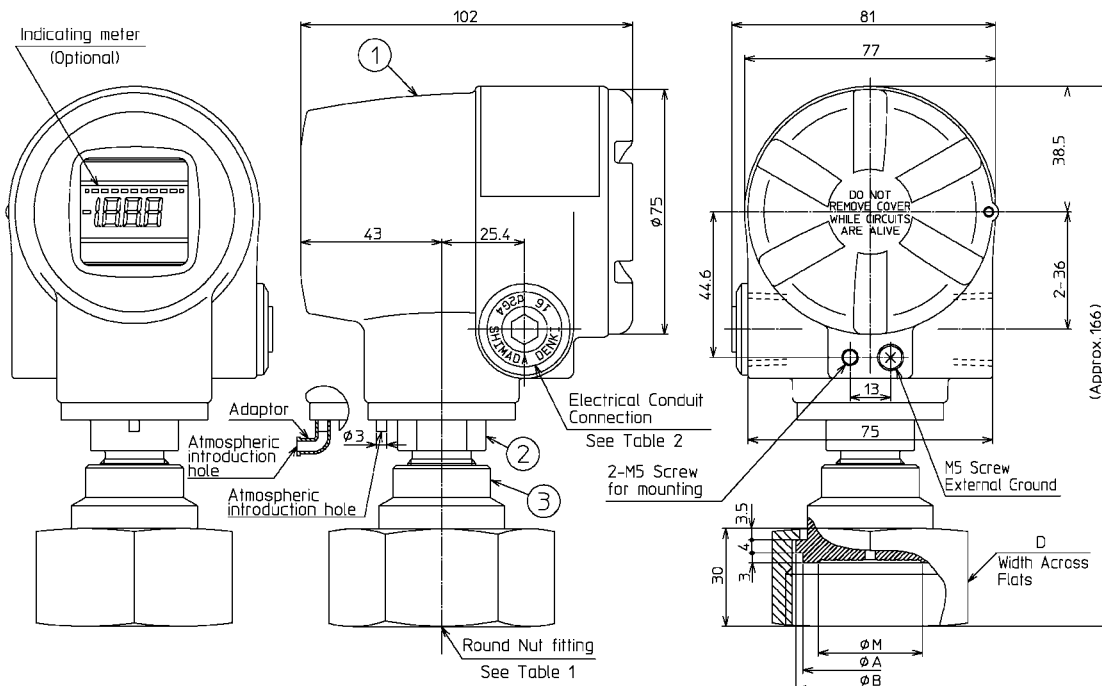

Table1 (See Inst. spec.)

Model No.	Fitting Size	D	ØM	A	B		
Rating Fitting	Size						
A	C	3	IDF 15S	60	28	42.7	47
		4	IDF 2S	75	43	56.2	60.5

Table2 (See Inst. spec.)

Model No.	Electrical Conduit Connection
A, B	G 1/2 Internal
N, D, L	1/2 NPT Internal

Table3 Terminal

Symbol	Terminal
SUPPLY +, SUPPLY -	Power supply and output signal
CHK+, CHK-	Check meter
⊥	Ground
ZERO	ZERO Adjuster

Ferrule with cooling tower (1 inch, 1 1/2 inch, 2 inches clamp type)



Measuring span / Setting range / Max. working pressure

Model Number	Measuring span	Setting Range	Max. Working Pressure	Process Connection
PTG7_K - _3	2.0 to 100 kPa	-100 to 100 kPa	200 kPa	2, 1 1/2S
PTG7_K - _4	40 to 400 kPa	-100 to 400 kPa	800 kPa or clamp rating	2S, 1 1/2S, 1S
PTG7_K - _5	0.2 to 2 MPa	-0.1 to 2 MPa	4 MPa or clamp rating	

Accuracy / Temperature effect

Model PTG7_K- _3

Accuracy *1	± 0.5% F.S. (100 kPa ≥ X ≥ 20 kPa) ± (0.5 × 20 / X)% F.S. (20 kPa ≥ X ≥ 2 kPa)	
Zero temperature effect per 30°C *1	2S (Clamp type)	± (2.5 × 40 / X + 0.35)%
	1 1/2S (Clamp type)	± (8.5 × 40 / X + 0.35)%

Model PTG7_K- _4

Accuracy *1	± 0.5% F.S. (400 kPa > X > 80 kPa) ± (0.5 × 80 / X)% F.S. (80 kPa > X > 40 kPa)	
Zero temperature effect per 30°C *1	2S (Clamp type)	± (1.4 × 80 / X + 0.35)%
	1 1/2S (Clamp type)	± (4.4 × 80 / X + 0.35)%
	1S (Clamp type)	± (37.5 × 80 / X + 0.35)%

Model PTG7_K- _5

Accuracy *1	± 0.5% F.S. (2 MPa > X > 0.4 MPa) ± (0.5 × 0.4 / X)% F.S. (0.4 MPa > X > 0.2 MPa)	
Zero temperature effect per 30°C *1	2S (Clamp type)	± (0.6 × 0.4 / X + 0.35)%
	1 1/2S (Clamp type)	± (1.2 × 0.4 / X + 0.35)%
	1S (Clamp type)	± (7.8 × 0.4 / X + 0.35)%

Note) *1: Within a range of URV ≥ 0 and LRV ≥ 0

Ambient temperature limits

Normal operating range

-10 to 60°C

Transportation and storage temperature

-20 to 70°C

Temperature range of wetted parts

-10 to 150°C

Ambient humidity limit

5 to 100% RH

Materials

Fill fluid

Propylene glycol

Wetted parts

Diaphragm

SUS316L

Others

SUS316

Case

Aluminum alloy

Weight

Approx. 1.4 kg

Process connection

- IDF 1S clamp
- IDF 1 1/2S clamp
- IDF 2S clamp

MODEL SELECTION

Smart pressure transmitter model PTG7XK

Process connection: Ferrule clamp type with cooling tower

Measuring span: 2.0 to 100 kPa, 40 to 400 kPa, 0.2 to 2 MPa

Model number structure: Basic model number - Selection - Option1 - Option2

Basic model number		Selection				Option1	Option2
Product description	Gauge pressure transmitter: Ferrule type with cooling tower with SFC communication	PTG71K					
	Gauge pressure transmitter: Ferrule type with cooling tower with SFC/ HART communication	PTG72K					
		-					
Type of protection	Water and dust proof: IEC IP67 Electrical connection:1/2NPT	N					
	FM Explosionproof Electrical connection:1/2NPT	D					
	FM Intrinsically safe Electrical connection: 1/2 NPT	E					
	NEPSI Flameproof Electrical connection:1/2NPT	L					
Measuring span	2.0 to 100 kPa (0.021 to 1.019 kgf/cm ²) (Applicable only for process connection 2S)	3					
	40 to 400 kPa (0.408 to 4.07 kgf/cm ²)	4					
	0.2 to 2MPa (2.04 to 20.3 kgf/cm ²)	5					
Material: Diaphragm / wetted parts other than diaphragm/fill fluid	SUS316L/ SUS316L/ Propylene glycol		CB				
Process connection	IDF 1½S ferrule clamp type			AH3X			
	IDF 2S ferrule clamp type			AH4X			
Option 1						-	
No option						X	
SFC communication DE output (Applicable only for model PTG72)						8	
Built-in digital indicator						M	
Heavy-duty corrosion-proof coating						B	
Wetted part finish	Oil free finish				G		
	Water and oil free finish				H		
	Electrolytic grinding				K		
	Passive state finish				W		
Option2						-	
No option							X
Test report							1
Material certificate							2
Over-pressure leak test							4
Strength calculation sheet (JIS)							5
Traceability certificate							6
Non SI unit							F
Mounting bracket							H
Electrical connection: M20 × 1.5 adapter							T

DIMENSIONS

[Unit: mm]

Materials of construction

KEY No.	Description	Materials
1	Case	Aluminum alloy
2	Body	SUS 316
3	Capillary A'ssy	SUS 316
4	Welded Part	SUS 316L

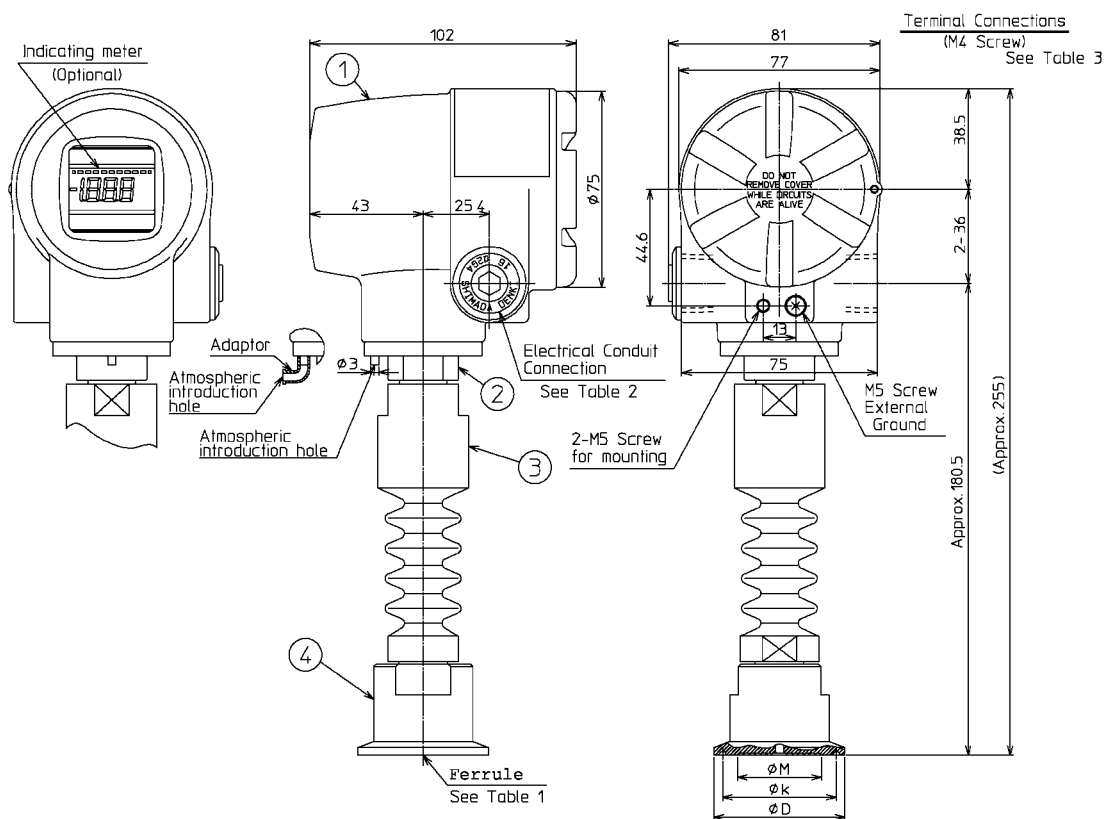
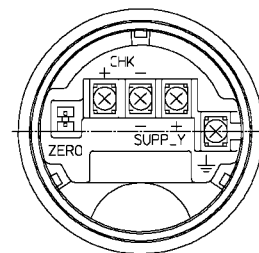

Table1 (See Inst. spec.)

Model No.		Ferrule Size		ϕD	ϕk	ϕM
Rating	Fitting	Size	Size			
A	H	2	IDF 1S	50.5	43.5	22
		3	IDF 15S			28
		4	IDF 2S	64	56.5	43

Table2 (See Inst. spec.)

Model No.	Electrical Conduit Connection	
A, B	G 1/2	Internal
N, D, L	1/2 NPT	Internal

Table3 Terminal

Symbol	Terminal
SUPPLY +, SUPPLY -	Power supply and output signal
CHK+, CHK-	Check meter
\perp	Ground
ZERO	ZERO Adjuster

Ferrule with cooling tower

(1½ inch, 2 inches cap nut type)



Measuring span/ Setting range/ Max. working pressure

Model Number	Measuring span	Setting Range	Max. Working Pressure	Process Connection
PTG7_K - _3	2.0 to 100kPa	-100 to 100 kPa	200 kPa	2S, 1½S
PTG7_K - _4	40 to 400 kPa	-100 to 400 kPa	800 kPa or cap nut rating	
PTG7_K - _5	0.2 to 2 MPa	-0.1 to 2 MPa	4 MPa or cap nut rating	

Accuracy / Temperature effect

Model PTG7_K- _3

Accuracy *1	± 0.5% F.S. (100kPa ≥ X ≥ 20 kPa) ± (0.5 × 20 / X)% F.S. (20k Pa ≥ X ≥ 2 kPa)
-------------	--

Zero temperature effect per 30°C *1	2S (Cap nut type)	± (2.5 × 40 / X + 0.35)%
	1½S (Cap nut type)	± (8.5 × 40 / X + 0.35)%

Model PTG7_K- _4

Accuracy *1	± 0.5% F.S. (400 kPa ≥ X ≥ 80 kPa) ± (0.5 × 80 / X)% F.S. (80 kPa ≥ X ≥ 40 kPa)
-------------	--

Zero temperature effect per 30°C *1	2S (Cap nut type)	± (1.4 × 80 / X + 0.35)%
	1½S (Cap nut type)	± (4.4 × 80 / X + 0.35)%

Model PTG7_K- _5

Accuracy *1	± 0.5% F.S. (2 MPa ≥ X ≥ 0.4 MPa) ± (0.5 × 0.4 / X)% F.S. (0.4 MPa ≥ X ≥ 0.2 MPa)
-------------	--

Zero temperature effect per 30°C *1	2S (Cap nut type)	± (0.6 × 0.4 / X + 0.35)%
	1½S (Cap nut type)	± (1.2 × 0.4 / X + 0.35)%

Note) *1: Within a range of URV ≥ 0 and LRV ≥ 0

Ambient temperature limits

Normal operating range

-10 to 60°C

Transportation and storage temperature

-20 to 70°C

Temperature ranges of wetted parts

-10 to 150°C

Ambient humidity limits

5 to 100% RH

Materials

Fill fluid

Propylene glycol

Wetted parts

Diaphragm

SUS316L

Others

SUS316

Case

Aluminum alloy

Weight

- 1½ inch: Approx. 1.6 kg
- 2 inches: Approx. 1.9 kg

Process connection

- IDF 1½S cap nut type
- IDF 2S cap nut type

MODEL SELECTION**Smart pressure transmitter model PTG7XK**

Process connection: Ferrule cap nut type with cooling tower

Measuring span 2.0 to 100 kPa, 40 to 400 kPa, 0.2 to 2 MPa

Model number structure: Basic model number - Selection - Option1 - Option2

Basic model number		-	Selection				-	Option1	-	Option2
Product description	Gauge pressure transmitter: Ferrule type with cooling tower with SFC communication	PTG71K								
	Gauge pressure transmitter: Ferrule type with cooling tower with SFC / HART Communication	PTG72K								
		-								
Type of protection	Water and dust proof: IEC IP67 Electrical connection: 1/2NPT		N							
	FM Explosionproof Electrical connection: 1/2NPT		D							
	FM Intrinsically safe Electrical connection: 1/2 NPT		E							
	NEPSI Flameproof Electrical connection: 1/2NPT		L							
Measuring span	2.0 to 100 kPa (0.021 to 1.019 kgf/cm ²) (Applicable only for process connection 2S)		3							
	40 to 400 kPa (0.408 to 4.07 kgf/cm ²)		4							
	0.2 to 2MPa (2.04 to 20.3 kgf/cm ²)		5							
Material: Diaphragm / wetted parts other than diaphragm/fill fluid	SUS316L / SUS316L / Propylene glycol			CB						
Process connection	IDF 1½S ferrule cap nut type					AC3X				
	IDF 2S ferrule cap nut type					AC4X				
Option 1							-			
No option								X		
SFC communication DE output (Applicable only for model PTG72)								8		
Built-in digital indicator								M		
Heavy-duty corrosion-proof coating								B		
Wetted part finish	Oil free finish						G			
	Water and oil free finish						H			
	Electrolytic grinding						K			
	Passive state finish						W			
Option2							-			
No option										X
Test report										1
Material certificate										2
Over-pressure leak test										4
Strength calculation sheet (JIS)										5
Traceability certificate										6
Non SI unit										F
Mounting bracket										H
Electrical connection: M20 × 1.5 adapter										T

DIMENSIONS

[Unit: mm]

Materials of construction

KEY No.	Description	Materials
1	Case	Aluminum alloy
2	Body	SUS 316
3	Capillary A'ssy	SUS 316
4	Welded Part	SUS 316L

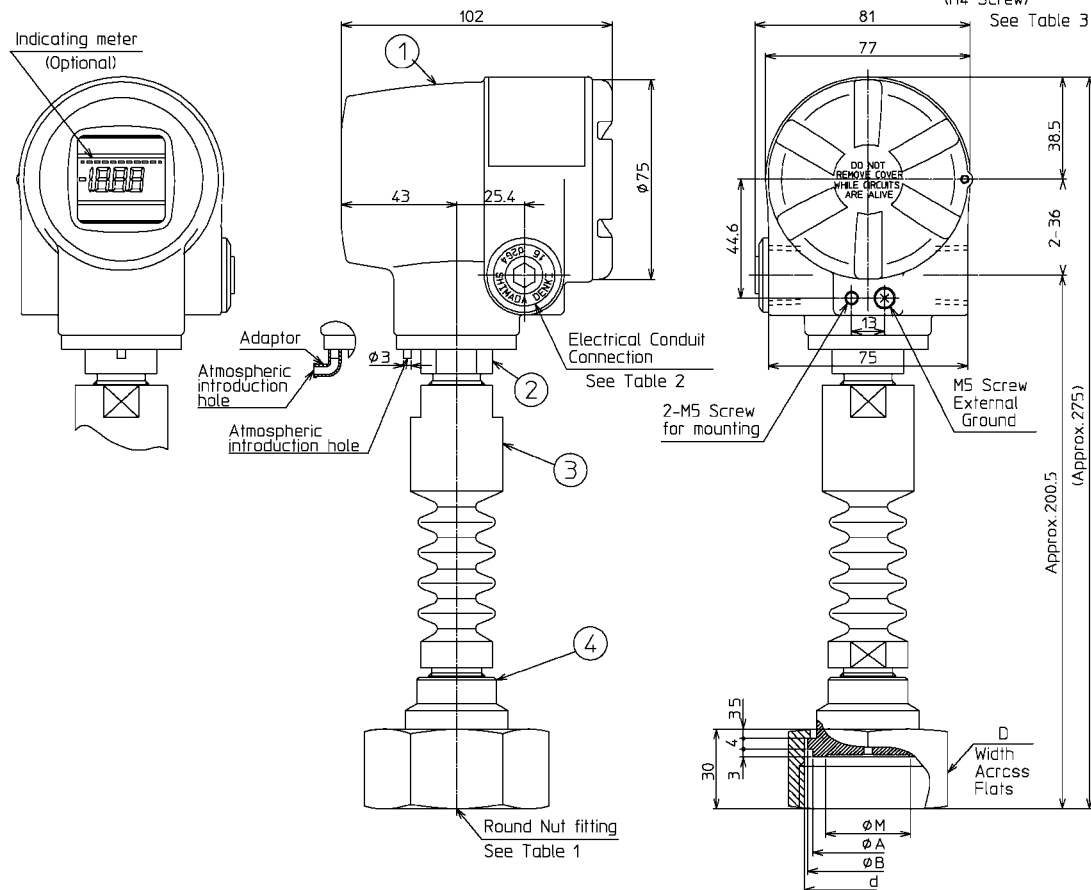

Table1 (See Inst. spec.)

Model No.	Fitting Size	Fitting Size(d)	D	φM	A	B	
A	C	3	IDF 1.5S	60	28	42.7	47
		4	IDF 2S	75	43	56.2	60.5

Table2 (See Inst. spec.)

Model No.	Electrical Conduit Connection
A, B	G 1/2 Internal
N, D, L	1/2 NPT Internal

Table3 Terminal

Symbol	Terminal
SUPPLY +, SUPPLY -	Power supply and output signal
CHK+, CHK-	Check meter
⊕	Ground
ZERO	ZERO Adjuster

Remote seal with ferrule type

(1½ inch, 2 inches clamp type)

**Measuring span/ Setting range/ Max. working pressure**

Model Number	Measuring span	Setting Range	Max. Working Pressure	Process Connection
PTG7_T - _3	2.0 to 100 kPa	-100 to 100 kPa	200 kPa	2S
PTG7_T - _4	40 to 400 kPa	-100 to 400 kPa	800 kPa or clamp rating	2S, 1½S
PTG7_T - _5	0.2 to 2 MPa	-0.1 to 2 MPa	4 MPa or clamp rating	

Accuracy / Temperature effect**Model PTG7_T- _3**

Accuracy *1	± 0.5% F.S. (100 kPa ≥ X ≥ 20 kPa) ± (0.5 × 20 / X)% F.S. (20 kPa ≥ X ≥ 2 kPa)
-------------	---

Zero temperature effect per 30°C *1	2S (Clamp type)	± (11.5 × 40 / X + 0.35)%
-------------------------------------	-----------------	---------------------------

Model PTG7_T- _4

Accuracy *1	± 0.5% F.S. (400 kPa ≥ X ≥ 80 kPa) ± (0.5 × 80 / X)% F.S. (80 kPa ≥ X ≥ 40 kPa)
-------------	--

Zero temperature effect per 30°C *1	2S (Clamp type)	± (5.9 × 80 / X + 0.35)%
	1½S (Clamp type)	± (21.7 × 80 / X + 0.35)%

Model PTG7_T- _5

Accuracy *1	± 0.5% F.S. (2 MPa ≥ X ≥ 0.4 MPa) ± (0.5 × 0.4 / X)% F.S. (0.4 MPa ≥ X ≥ 0.2 MPa)
-------------	--

Zero temperature effect per 30°C *1	2S (Clamp type)	± (1.5 × 0.4 / X + 0.35)%
	1½S (Clamp type)	± (4.65 × 0.4 / X + 0.35)%

Note) *1: Within a range of URV ≥ 0 and LRV ≥ 0

Ambient temperature limits**Normal operating ranges**

1 ½ inch -5 to 55°C

2 inches -5 to 60°C

Transportation and storage temperature

-20 to 70°C

Temperature range of wetted parts

-10 to 110°C

150°C for 30 minutes during steam cleaning

Ambient humidity limits

5 to 100% RH

Materials**Fill fluid**

Propylene glycol

Wetted parts**Diaphragm**

SUS316L

Others

SUS316

Case

Aluminum alloy

Capillary cover

Olefin

Weight

Approx. 1.8 kg (Capillary length 3 m)

Process connection

- IDF 1½S clamp type
- IDF 2S clamp type

MODEL SELECTION

Smart pressure transmitter model PTG7XT

Process connection: Remote seal with ferrule clamp type

Measuring span: 2.0 to 100 kPa, 40 to 400 kPa, 0.2 to 2 MPa

Model number structure: Basic model number - Selection - Option1 - Option2

			Selection				Option1	Option2
Product description	Gauge pressure transmitter: Ferrule type with remote seal with SFC Communication	PTG71T						
	Gauge pressure transmitter: Ferrule type with remote seal with SFC / HART Communication	PTG72T						
Type of protection	Water and dust proof: IEC IP67 Electrical connection: 1/2NPT		N					
	FM Explosionproof Electrical connection: 1/2NPT		D					
	FM Intrinsically safe Electrical connection: 1/2 NPT		E					
	NEPSI Flameproof Electrical connection: 1/2NPT		L					
Measuring span	2.0 to 100 kPa (0.021 to 1.019 kgf/cm ²) (Not applicable for process connection 1S)			3				
	40 to 400 kPa (0.408 to 4.07 kgf/cm ²)			4				
	0.2 to 2MPa (2.04 to 20.3 kgf/cm ²)			5				
Material: Diaphragm / wetted parts other than diaphragm/fill fluid	SUS316L/SUS316L/Propylene glycol				CB			
Process connection	IDF1½S ferrule clamp type					AH3X		
	IDF 2S ferrule clamp type					AH4X		
Capillary length	1m (with Olefin tube)					E		
	3m (with Olefin tube)					G		
	5m (with Olefin tube)					J		
Option 1							-	
No option							X	
SFC communication DE output (Applicable only for model PTG72)							8	
Heavy-duty corrosion-proof coating							B	
Built-in digital indicator							M	
Wetted parts finish	Oil free finish						G	
	Water and oil free finish						H	
	Electrolytic grinding						K	
	Passive state finish						W	
Option2							-	
No option							X	
Test report							1	
Material certificate							2	
Over-pressure leak test							4	
Strength calculation sheet (JIS)							5	
Traceability certificate							6	
Non SI unit							F	
Mounting bracket							H	
Electrical connection: M20 × 1.5 adapter							T	

DIMENSIONS

[Unit: mm]

Materials of construction

KEY No.	Description	Materials
1	Case	Aluminum alloy
2	Body	SUS 316
3	Capillary A'ssy	SUS 304(Olefin cover)
4	Wetted Part	SUS 316L

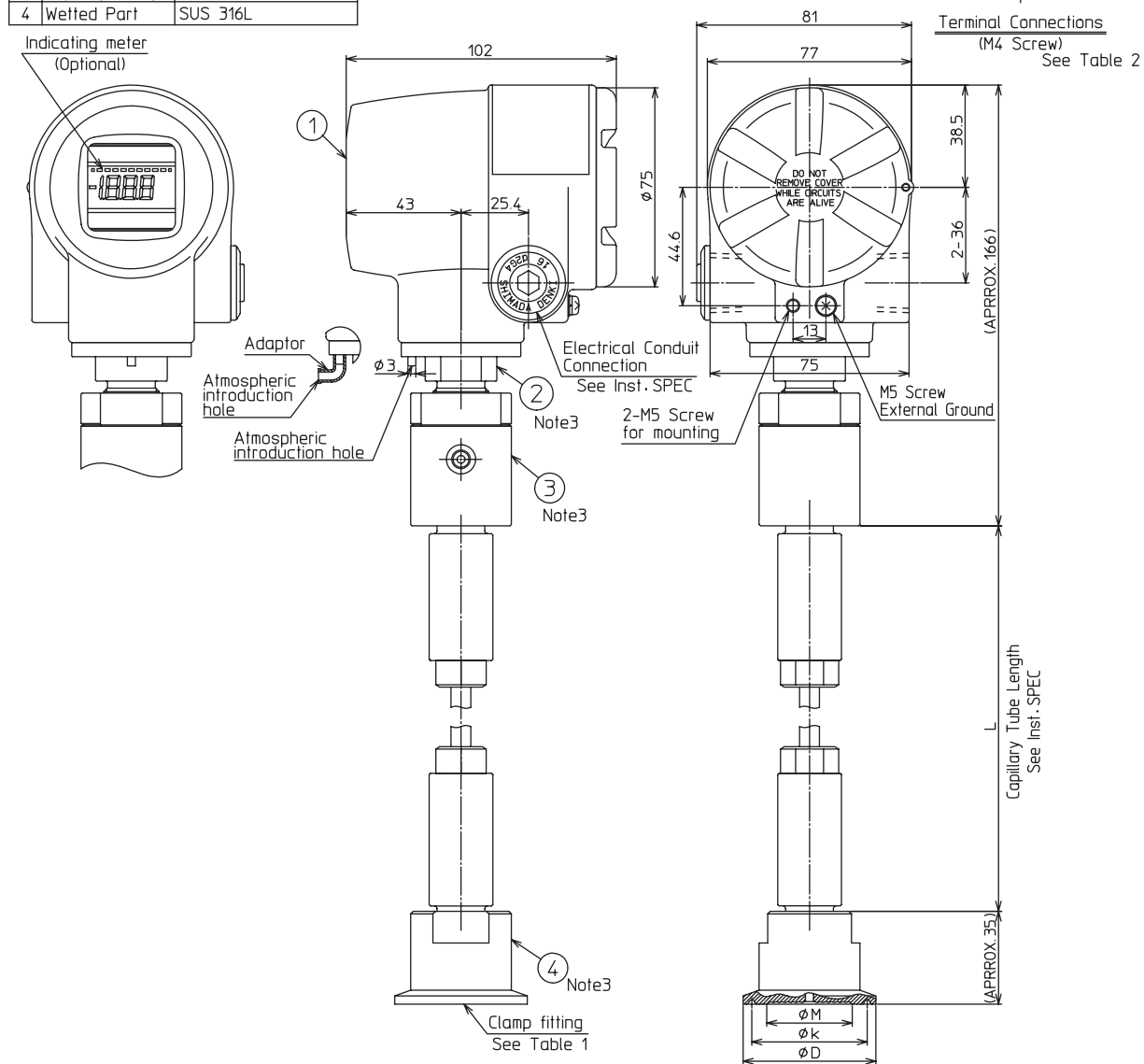

Table1 (See Inst. spec.)

Rating	Fitting	Model No.		Ferrule Size	φD	φk	φM
		Size	Size				
A	H	2	IDF 1S	50.5	43.5	22	
		3	IDF 1.5S	50.5	43.5	28	
		4	IDF 2S	64	56.5	43	

Table2 Terminal

Symbol	Terminal
SUPPLY +, SUPPLY -	Power supply and output signal
CHK +, CHK -	Check meter
⊥	Ground
ZERO	ZERO Adjuster

Remote seal with ferrule type

(1½ inch, 2 inches cap nut type)



Measuring span/ Setting range/ Max. working pressure

Model Number	Measuring span	Setting Range	Max. Working Pressure	Process Connection
PTG7_T - _3	2.0 to 100 kPa	-100 to 100 kPa	200 kPa	2S
PTG7_T - _4	40 to 400 kPa	-100 to 400 kPa	800 kPa or cap nut rating	2S, 1½S
PTG7_T - _5	0.2 to 2 MPa	-0.1 to 2 MPa	4 MPa or cap nut rating	

Accuracy / Temperature effect

Model PTG7_T - _3

Accuracy *1	± 0.5% F.S. (100 kPa ≥ X ≥ 20 kPa) ± (0.5 × 20 / X)% F.S. (20 kPa ≥ X ≥ 2 kPa)
-------------	---

Zero temperature effect per 30°C *1	2S (Cap nut type) ± (11.5×40 / X +0.35)%
-------------------------------------	--

Model PTG7_T - _4

Accuracy *1	± 0.5% F.S. (400 kPa ≥ X ≥ 80 kPa) ± (0.5 × 80 / X)% F.S. (80 kPa ≥ X ≥ 40 kPa)
-------------	--

Zero temperature effect per 30°C *1	2S (Cap nut type) ± (5.9 × 80 / X +0.35)%
	1½S (Cap nut type) ± (21.7 × 80 / X +0.35)%

Model PTG7_T - _5

Accuracy *1	± 0.5% F.S. (2 MPa > X > 0.4 MPa) ± (0.5 × 0.4 / X)% F.S. (0.4 MPa > X > 0.2 MPa)
-------------	--

Zero temperature effect per 30°C *1	2S (Cap nut type) ± (1.5 × 0.4 / X +0.35)%
	1½S (Cap nut type) ± (4.65 × 0.4 / X +0.35)%

Note) *1: Within a range of URV ≥ 0 and LRV ≥ 0

Ambient temperature limits

Normal operating range

-5 to 60°C

Transportation and storage temperature

-20 to 70°C

Temperature range of wetted parts

-5 to 121°C

150°C for 30 minutes during steam cleaning

Ambient humidity limits

5 to 100% RH

Materials

Fill fluid

Propylene glycol

Wetted parts

Diaphragm

SUS316L

Others

SUS316

Case

Aluminum alloy

Capillary cover

Olefin

Weight

Approx. 2.3 kg (Capillary length 3 m)

Process connection

- IDF 1½S cap nut type
- IDF 2S cap nut type

MODEL SELECTION**Smart pressure transmitter model PTG7XT**

Process connection: Remote seal with ferrule cap nut type

Measuring span 2.0 to 100 kPa, 40 to 400 kPa, 0.2 to 2 MPa

Model number structure: Basic model number - Selection - Option1 - Option 2

			Selection					Option1	Option2
Product description	Gauge pressure transmitter: Ferrule type with remote seal with SFC communication	PTG71T							
	Gauge Pressure Transmitter: Ferrule type with remote seal with SFC / HART Communication	PTG72T							
			-						
Type of protection	Water and dust proof: IEC IP67 Electrical connection: 1/2NPT		N						
	FM Explosionproof Electrical connection: 1/2NPT		D						
	FM Intrinsically safe Electrical connection: 1/2 NPT		E						
	NEPSI Flameproof Electrical connection: 1/2NPT		L						
Measuring span	2.0 to 100 kPa (0.021 to 1.019 kgf/cm ²)			3					
	40 to 400 kPa (0.408 to 4.07 kgf/cm ²)			4					
	0.2 to 2 MPa (2.04 to 20.3 kgf/cm ²)			5					
Material: Diaphragm / wetted parts other than diaphragm/fill fluid	SUS316L / SUS316L / Propylene glycol				CB				
Process connection	IDF 1½S ferrule cap nut type					AC3X			
	IDF 2S ferrule cap nut type					AC4X			
Capillary length	1m (with Olefin tube)					E			
	3m (with Olefin tube)					G			
	5m (with Olefin tube)					J			
Option 1							-		
No option								X	
SFC communication DE output (Applicable only for model PTG72)								8	
Heavy-duty corrosion-proof coating								B	
Built-in digital indicator								M	
Wetted parts finish	Oil free finish						G		
	Water and oil free finish						H		
	Electrolytic grinding						K		
	Passive state finish						W		
Option2								-	
No option								X	
Test report								1	
Material certificate								2	
Over-pressure leak test								4	
Strength calculation sheet (JIS)								5	
Traceability certificate								6	
Non SI unit								F	
Mounting bracket								H	
Electrical connection: M20 × 1.5 adapter								T	

