

PTG series

Pressure Transmitter Bravolight

Model PTG60

OVERVIEW

The Smart Pressure Transmitter model PTG is a high-performance, highly reliable gauge pressure transmitter. Based on Yamatake's proven Smart Transmitter technologies, the model PTG offers improved performance and reliability with size, weight and cost advantages. An optional, built-in digital indicator allows the pressure transmitter to be used in a wide variety of applications.



FEATURES

Compact and lightweight

- Approx. 0.9 kg (Screw connection type)

Broad range setting

- Range from -100 kPa to 50 MPa.
- Span from 2.0 kPa to 50 MPa.

Note) Screw connection type. Covered with five ranges.

Remote communication (Optional)

Any range can be set using the SFC. This further increases range flexibility and keeps inventory down.

Built-in digital indicator (Optional)

The built-in digital indicator option effectively checks output on site.

Type of protection

- Water and dust proof for IEC IP67, NEMA3 and 4X

External views of the PTG series



*Model PTG60G
(Screw type)*



*Model PTG60B
(Flush diaphragm type)*



*Model PTG60F
(Flange type)*



*Model PTG60S
(Ferrule clamp type)*



*Model PTG60S
(Ferrule cap nut type)*



*Model PTG60K
(Ferrule clamp type
with cooling tower)*



*Model PTG60K
(Ferrule cap nut type
with cooling tower)*



*Model PTG60T
(Remote seal with ferrule type)*



*Model PTG60T
(Remote seal with ferrule cap nut type)*

COMMON SPECIFICATIONS

Type of protection

JIS C0920 watertight, JIS F8001 class 2 water or equivalent, NEMA 3 and 4X, IEC IP67

Supply voltage and load resistance

Refer to Figure 1.

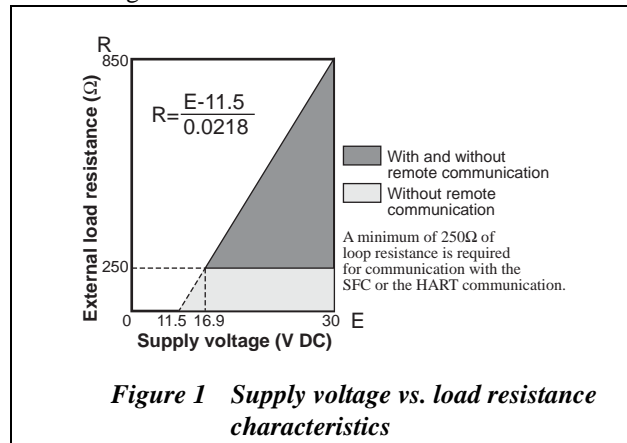

Power supply and voltage effect

0.005% F.S./V

Output / Communication

Analog output (4 to 20mA) two-wire

Response speed

Approx. 400 ms

Vibration Tolerance

Less than 100 Hz : 2 G
100 to 2000 Hz : 1 G

Zero adjustment

Internal zero adjustment function

CE conformity

- EN50081-2-1993, Electromagnetic Compatibility- Generic Emission Standard, Part 2: Industrial Environment
- EN50082-2-1995, Electromagnetic Compatibility- Generic Immunity Standard, Part 2: Industrial Environment
- EN61010-1-1993, Safety requirements for electrical equipment, control and laboratory use, Part: General requirement

Finish

Baked acrylic paint, metallic green (Munsell 5G7/8)

Electrical connection

1/2 NPT internal thread

Mounting

- Direct mounting on a pipe (line mount)
- 2-inch pipe mounting
- Wall mounting

When mounting a PTG transmitter, consider its characteristics against vibration and overall vibration including piping. Use an optional mounting bracket when mounting it onto 2-inch pipe or wall.

Optional specifications

Built-in indicating meter

The digital LCD indicator (optional) displays engineering units and can be set freely between -1999 and 1999 (3.5 digits).

Mounting bracket

Bracket for 2-inch pipe or wall mounting (For thread connection type and ferrule remote sealed type)

Oil free finish

Oil is removed from the wetted parts before shipment.

Oil and water free finish

Oil and water are removed from the wetted parts before shipment.

Electrolytic grinding (For ferrule type only)

The surface of the wetted parts is smoothed by electrolytic grinding.

Passive state finish (For ferrule type only)

The surface of the wetted parts is treated with a passive state finish to form a protective film to increase resistance to corrosion.

Corrosion-resistant finish

Corrosion-proof paint (Baked epoxy paint), fungus-proof finish

Working range of negative pressure

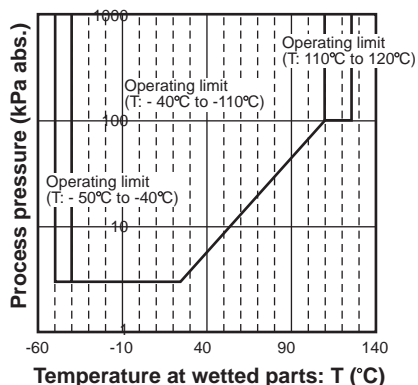

Figure 2 Minimum working pressure for model PTG60G

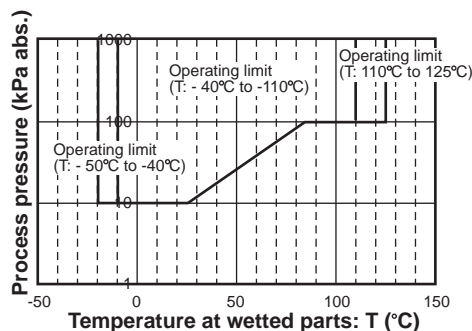

Figure 3 Minimum working pressure for model PTG60S, model PTG60T Minimum working pressure combination of model PTG60F and propylene glycol.

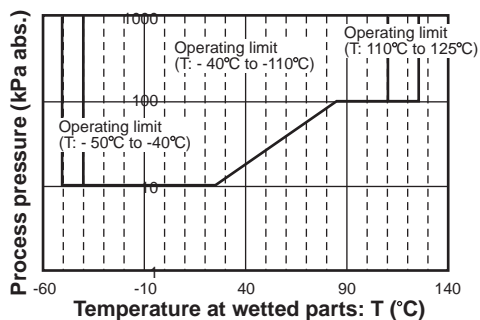

Figure 4 Minimum working pressure for combination of model PTG60B or model PTG60F

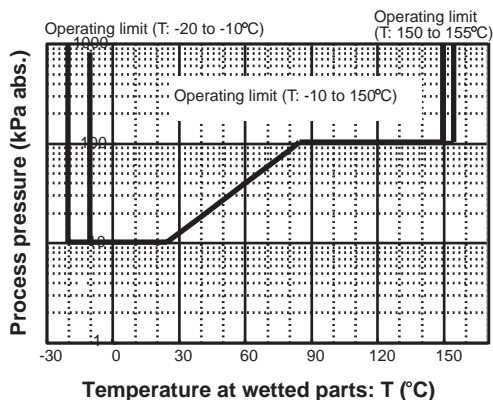
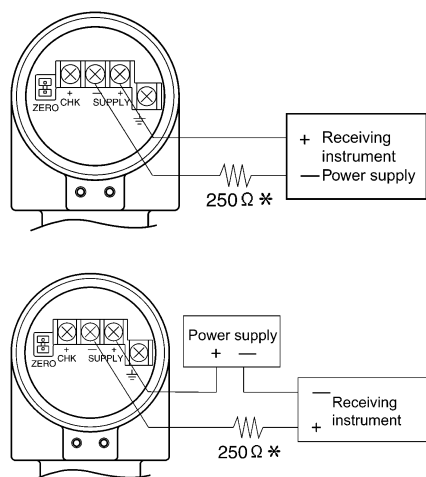

Figure 5 Minimum working pressure for model PTG60K



Note) *A minimum of 250 Ω of loop resistance is required for communication with the SFC

Index of detailed specifications for process connection types

Process connection	Process connection style	Measurement span	Reference page
Screw type PTG60G	G3/8 external thread G1/2 external thread Rc3/8 internal thread Rc1/2 internal thread 1/2NPT internal thread M20 × 1.5 external	2.0 to 100 kPa {0.021 to 1.019 kgf/cm ² } 40 to 400 kPa {0.408 to 4.07 kgf/cm ² } 0.2 to 2 MPa {2.04 to 20.3 kgf/cm ² } 1 to 10 MPa {10.20 to 101.9 kgf/cm ² }	6 to 11
	Rc1/4 internal thread G1/2 external thread 1/4NPT internal thread M20 × 1.5 external thread	5 to 50 Mpa {51.0 to 509 kgf/cm ² }	
Flush diaphragm type PTG60B	G2-inch external thread	2.0 to 100 kPa {0.021 to 1.019 kgf/cm ² } 40 to 400 kPa {0.408 to 4.07 kgf/cm ² } 0.2 to 2 MPa {2.04 to 20.3 kgf/cm ² } 1 to 10 MPa {10.20 to 101.9 kgf/cm ² }	12 to 14
	G1/2-inch external thread	0.2 to 2 MPa {2.04 to 20.3 kgf/cm ² } 1 to 10 MPa {10.20 to 101.9 kgf/cm ² }	
Flange type PTG60F	JIS10K 50mm JIS30K 50mm JPI/ANSI150 2 inches JPI/ANSI300 2 inches JPI/ANSI600 2 inches JIS10K 15 mm JIS30K 15 mm JPI/ANSI150 ½ inch JPI/ANSI300 ½ inch JPI/ANSI600 ½ inch	2.0 to 100 kPa {0.021 to 1.019 kgf/cm ² } 40 to 400 kPa {0.408 to 4.07 kgf/cm ² } 0.2 to 2 MPa {2.04 to 20.3 kgf/cm ² } 1 to 10 MPa {10.20 to 101.9 kgf/cm ² }	15 to 18
Ferrule type (Direct mount) PTG60S	IDF 2S clamp IDF 1½S clamp IDF 1S clamp	2.0 to 100 kPa {0.021 to 1.019 kgf/cm ² } 40 to 400 kPa {0.408 to 4.07 kgf/cm ² } 0.2 to 2 MPa {2.04 to 20.3 kgf/cm ² }	19 to 21
	IDF 2S cap nut IDF 1½S cap nut	2.0 to 100 kPa {0.021 to 1.019 kgf/cm ² } 40 to 400 kPa {0.408 to 4.07 kgf/cm ² } 0.2 to 2 MPa {2.04 to 20.3 kgf/cm ² }	22 to 24
Ferrule type with cool- ing tower PTG60K	IDF 2S clamp IDF 1½S clamp	2.0 to 100 kPa {0.021 to 1.019 kgf/cm ² } 40 to 400 kPa {0.408 to 4.07 kgf/cm ² } 0.2 to 2 MPa {2.04 to 20.3 kgf/cm ² }	25 to 27
	IDF 1S clamp	40 to 400 kPa {0.408 to 4.07 kgf/cm ² } 0.2 to 2 MPa {2.04 to 20.3 kgf/cm ² }	
	IDF 2S cap nut IDF 1½ inch cap nut	2.0 to 100 kPa {0.021 to 1.019 kgf/cm ² } 40 to 400 kPa {0.408 to 4.07 kgf/cm ² } 0.2 to 2 MPa {2.04 to 20.3 kgf/cm ² }	28 to 30
Remote seal with fer- rule type (Capillary 1, 3, 5 m) PTG60T	IDF 2S clamp	2.0 to 100 kPa {0.021 to 1.019 kgf/cm ² } 40 to 400 kPa {0.408 to 4.07 kgf/cm ² } 0.2 to 2 MPa {2.04 to 20.3 kgf/cm ² }	31 to 33
	IDF 1½S clamp	40 to 400 kPa {0.408 to 4.07 kgf/cm ² } 0.2 to 2 MPa {2.04 to 20.3 kgf/cm ² }	
	IDF 2S cap nut	2.0 to 100 kPa {0.021 to 1.019 kgf/cm ² } 40 to 400 kPa {0.408 to 4.07 kgf/cm ² } 0.2 to 2 MPa {2.04 to 20.3 kgf/cm ² }	34 to 36
	IDF 1½S cap nut	40 to 400 kPa {0.408 to 4.07 kgf/cm ² } 0.2 to 2 MPa {2.04 to 20.3 kgf/cm ² }	

Screw type



Ambient temperature limits

Normal operating range

-25 to 70°C

Transportation and storage temperature

-40 to 70°C

Temperature range of wetted parts

-40 to 110°C

Ambient humidity limits

5 to 100% RH

Materials

Fill fluid

Silicone oil

Wetted parts

Diaphragm

SUS316L

Others

SUS316

Case

Aluminum alloy

Weight

Approx. 0.9 kg

Measuring span / Setting range / Max. working pressure

Model no.	Measuring span	Setting range	Max. working pressure	Process connection
PTG60G- <u>3</u>	2.0 to 100 kPa	-100 to 100 kPa	200 kPa	Rc3/8 internal thread, Rc1/2 internal thread, G3/8 external thread, G1/2 external thread, 1/2NPT internal thread.
PTG60G- <u>4</u>	40 to 400 kPa	-100 to 400 kPa	800 kPa	
PTG60G- <u>5</u>	0.2 to 2 MPa	-0.1 to 2 MPa	4 MPa	
PTG60G- <u>6</u>	1 to 10 MPa	-0.1 to 10MPa	20 MPa	
PTG60G- <u>7</u>	5 to 50 MPa	-0.1 to 50 MPa	75 MPa*	

Note) * 62.5 MPa for explosion-proof type

Accuracy / Temperature effect

Model PTG60G- 3

Accuracy *1	± 0.5% F.S. (100 kPa > X > 20 kPa) ± (0.5 × 20 / X)% F.S. (20 kPa > X > 2 kPa)
--------------------	---

Zero temperature effect per 30°C *1	± (0.5×40 / X + 0.35)%
--	------------------------

Model PTG60G- 4

Accuracy *1	± 0.5% F.S. (400 kPa > X > 80 kPa) ± (0.5 × 80 / X)% F.S. (80 kPa > X > 40 kPa)
--------------------	--

Zero temperature effect per 30°C *1	± (0.4 × 80 / X + 0.35)%
--	--------------------------

Model PTG60G- 5

Accuracy *1	± 0.5% F.S. (2.0 MPa > X > 0.4 MPa) ± (0.5 × 0.4 / X)%F.S. (0.4 MPa > X > 0.2 MPa)
--------------------	---

Zero temperature effect per 30°C *1	± (0.4 × 0.4 / X + 0.35)%
--	---------------------------

Model PTG60G- 6

Accuracy *1	± 0.5% F.S. (10 MPa > X > 2.0 MPa) ± (0.5 × 2.0 / X)% F.S. (2.0 MPa > X > 5.0 MPa)
--------------------	---

Zero temperature effect per 30°C *1	± (0.4 × 2.0 / X + 0.35)%
--	---------------------------

Model PTG60G- 7

Accuracy *1	± 0.5% F.S. (50 MPa > X > 10 MPa) ± (0.5 × 10.0 / X)% F.S. (10 MPa > X > 5.0 MPa)
--------------------	--

Zero temperature effect per 30°C *1	± (0.4 × 10.0 / X+ 0.35)%
--	---------------------------

Note) *1: Within a range of URV ≥ 0 and LRV ≥ 0

For other specification, please refer to COMMON SPECIFICATIONS.

MODEL SELECTION

Smart Pressure Transmitter model PTG60G

Process connection: Screw type

Measuring span: 2.0 to 100 kPa, 40 to 400 kPa, 0.2 to 2 MPa, 1 to 10 MPa, 5 to 50 MPa

Model number structure: Basic model number - selection - Option1 - Option2

Basic model number		PTG60G	-	Selection				-	Option1	-	Option2
Product description	Gauge pressure transmitter: Screw connection type	PTG60G	-								
Type of protection	Water and dust proof: IEC IP67 Electrical conduit: G1/2			G							
Measuring span	2.0 to 100 kPa (0.021 to 1.019 kgf/cm ²)				3						
	40 to 400 kPa (0.408 to 4.07 kgf/cm ²)				4						
	0.2 to 2 MPa (2.04 to 20.3 kgf/cm ²)				5						
	1 to 10 MPa (10.20 to 101.9 kgf/cm ²)				6						
	5 to 50 MPa (51.0 to 509 kgf/cm ²)				7						
Material: Diaphragm / wetted parts other than diaphragm / fill fluid	SUS316L / SUS316 / Silicone oil					B1					
Process connection	G1/2 external thread						G4				
	G3/8 external thread (Not applicable for measuring span code "7")						G3				
	Rc1/4 internal thread (Applicable only for measuring span code "7")						C2				
	Rc1/2 internal thread (Not applicable for measuring span code "7")						C4				
	Rc3/8 internal thread (Not applicable for measuring span code "7")						C3				
	1/4NPT internal thread (Applicable only for measuring span code "7")						N2				
	1/2NPT internal thread (Not applicable for measuring span code "7")						N4				
Option 1								-			
No option									X		
Built-in digital indicator									M		
Heavy duty corrosion-proof coating									B		
Remote communication function									C		
Wetted parts finish	Oil free finish							G			
	Water and oil free finish							H			
Option2								-			
No option										X	
Test report										1	
Material certificate										2	
Documents conforming to Japanese high pressure gas control law										3	
Over-pressure leak test										4	
Strength calculation sheet (JIS)										5	
Traceability certificate										6	
Mounting bracket										H	
Certificate of oil free finish										J	
Documents conforming to Japanese high pressure gas control law and thickness test report										Y	

DIMENSIONS

[Unit: mm]

Materials of construction

KEY No.	Description	Materials
1	Case	Aluminum alloy
2	Body	SUS 316 (Diaphragm SUS 316L)
3	Joint	SUS 316

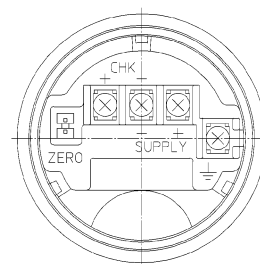

Terminal Connection
(M2 Screw)

See Table 3

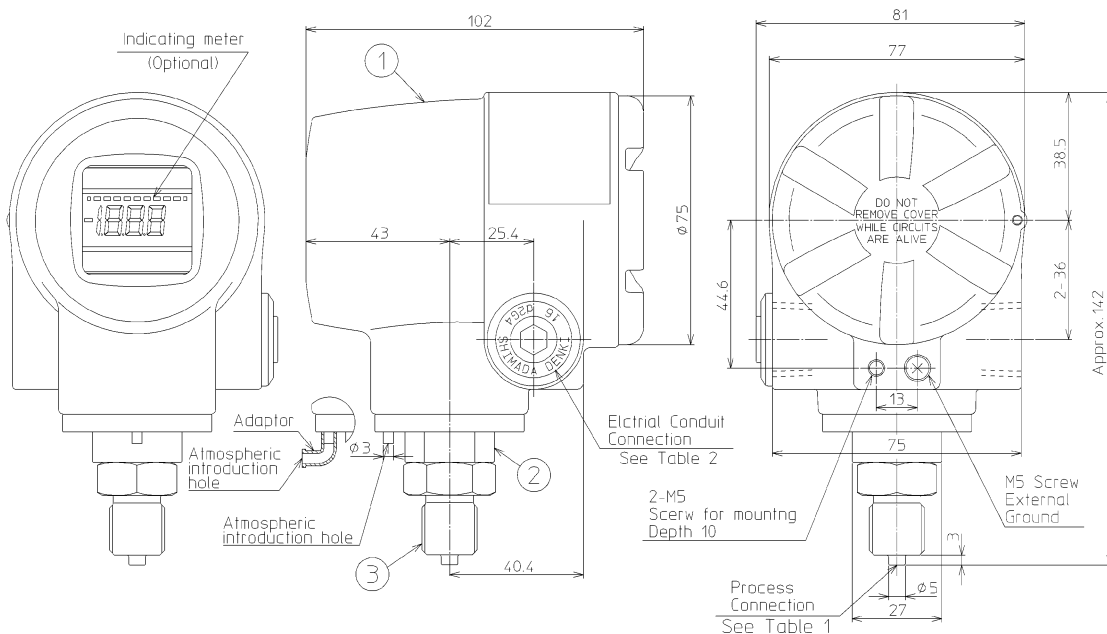

Table1 (See Inst. spec.)

Mode No.	Thread Type of Process Connection	
Thread Type	Thread Size	
G	3	G3/8 External

Table2 (See Inst. spec.)

Mode No. Selection	Optional2	Electrical Conduit Connection
A·B	—	G 1/2 Internal
	—	1/2NPT Internal
N·D·L	T	M20 Internal (1 pc)
	U	M20 Internal (2 pcs)

Table3 Terminal

Symbol	Terminal
SUPPLY +, SUPPLY -	Power supply and output signal
CHK+, CHK-	Check meter
⏏	Ground
ZERO	ZERO Adjuster

Process connection :G3/8 External

[Unit: mm]

Materials of construction

KEY No.	Description	Materials
1	Case	Aluminum alloy
2	Body	SUS 316 (Diaphragm SUS 316L)
3	Joint	SUS 316

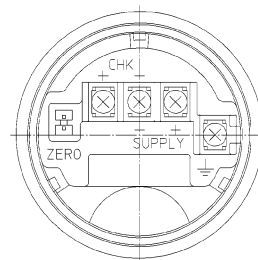

Terminal Connection
(M2 Screw)

See Table 3

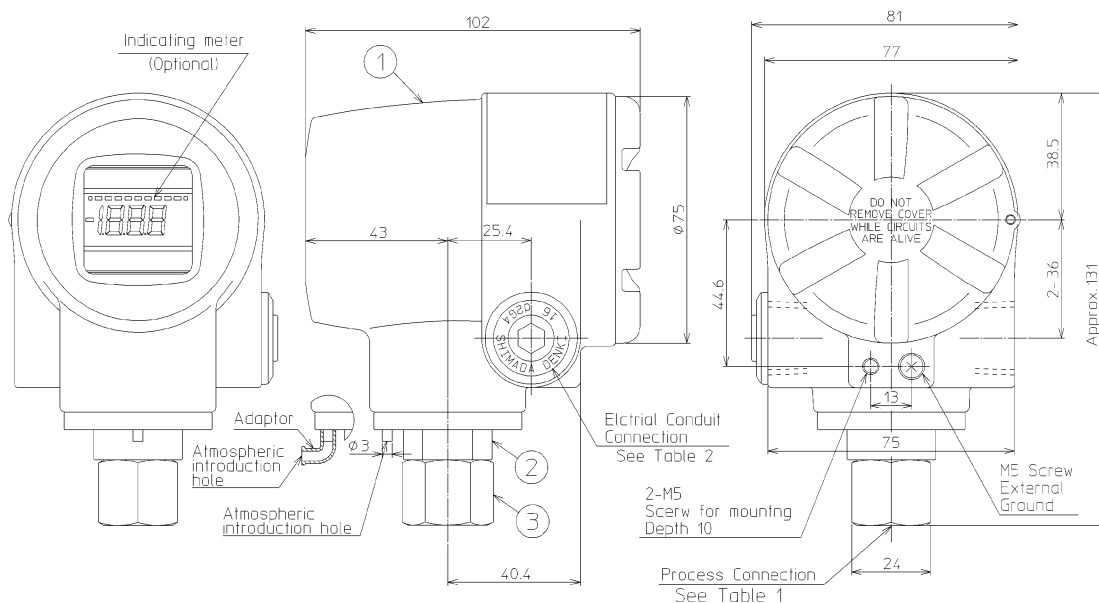

Table1 (See Inst. spec.)

Mode No.	Thread Type	Thread Size	Process Connection
C		3	Rc3/8 Internal

Table2 (See Inst. spec.)

Mode No.	Selection	Optional2	Electrical Conduit Connection
A·B	—		G 1/2 Internal
	—		1/2NPT Internal
N·D·L	T		M20 Internal (1 pc)
	U		M20 Internal (2 pcs)

Table3 Terminal

Symbol	Terminal
SUPPLY +, SUPPLY -	Power supply and output signal.
CHK+, CHK-	Check meter
⏏	Ground
ZERO	ZERO Adjuster

Process connection : Rc3/8 Internal

[Unit: mm]

Materials of construction

KEY No.	Description	Materials
1	Case	Aluminum alloy
2	Body	SUS 316 (Diaphragm SUS 316L)

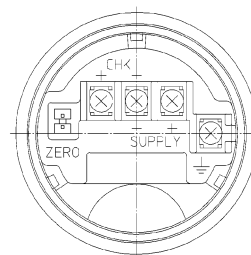

Terminal Connection
(M4 Screw)
See Table 3

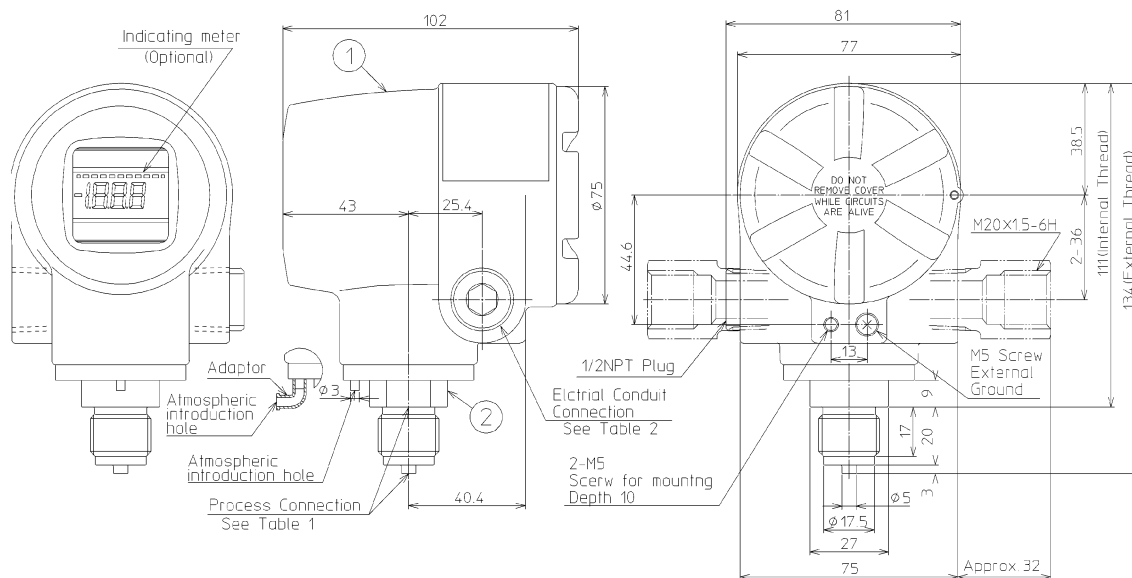

Table1 (See Inst. spec.)

Mode No.	Thread Type of Process Connection
G	4 G1/2 External
N	4 NPT 1/2 Internal
C	4 Rc 1/2 Internal

Table2 (See Inst. spec.)

Mode No.	Electrical Conduit Connection
N.D.L	— 1/2NPT Internal
T	M20 Internal (1 pc)
U	M20 Internal (2 pcs)

Table3 Terminal

Symbol	Terminal
SUPPLY +, SUPPLY -	Power supply and output signal
CHK+, CHK-	Check meter
⏏	Ground
ZERO	ZERO Adjuster

Process connection : G1/2 External
 : 1/2NPT internal
 : M20x15 External

[Unit: mm]

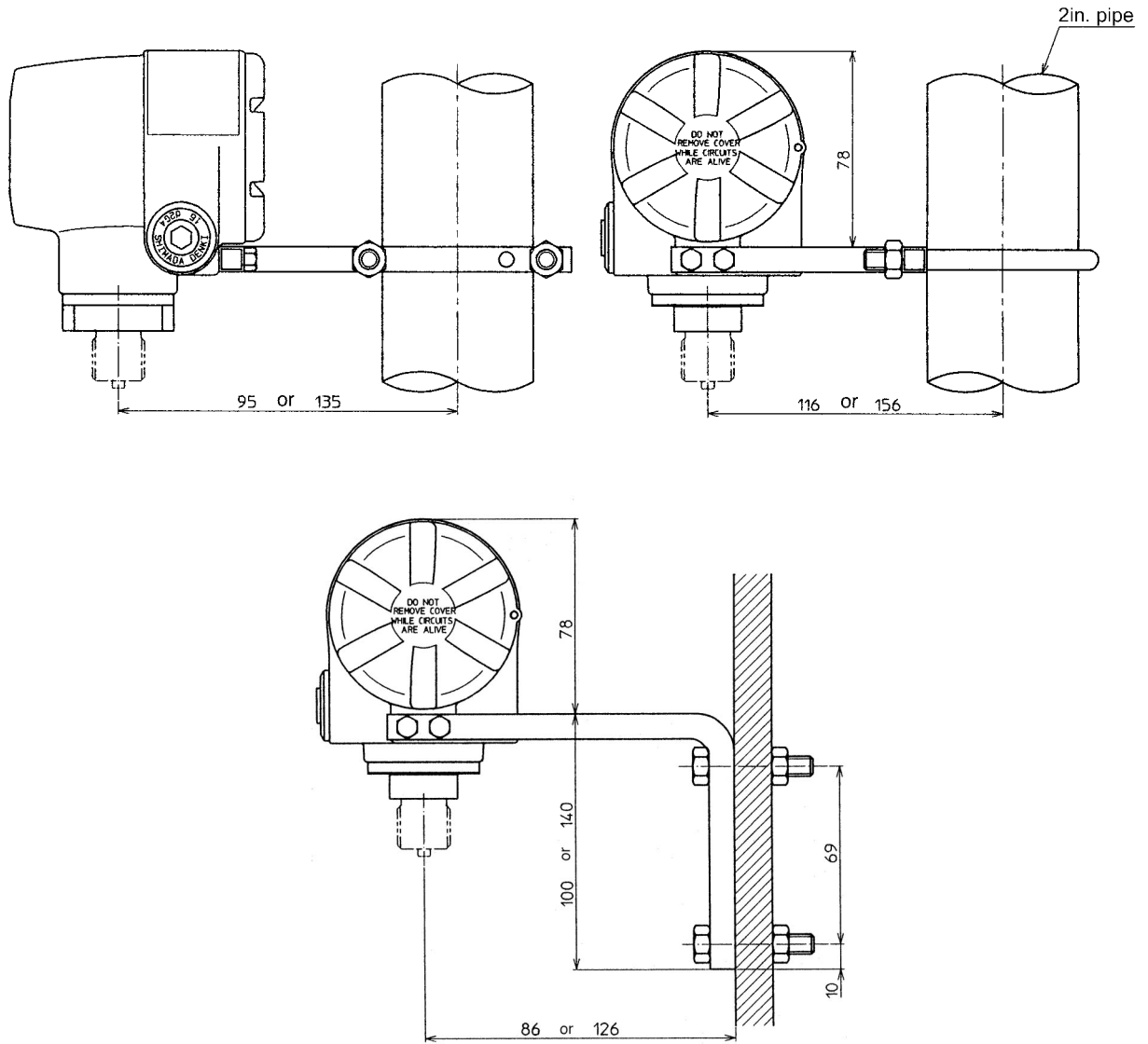

Flush diaphragm type

(G2 inch external, G1/2 inch external / flush diaphragm)



Measuring span / Setting range / Max. working pressure

Model number	Measuring span	Setting range	Max. working pressure	Process connection
PTG60B- -_3	2.0 to 100 kPa	-100 to 100 kPa	200kPa	G2 external thread
PTG60B- -_4	40 to 400 kPa	-100 to 400 kPa	800kPa	
PTG60B- -_5	0.2 to 2 MPa	-0.1 to 2 MPa	4MPa	G2 external thread G1/2 external thread
PTG60B- -_6	1 to 10 MPa	-0.1 to 10 MPa	20MPa	

Accuracy / Temperature effect

Model PTG60B- _3

Accuracy *1	± 0.5% F.S. (100 kPa ≥ X ≥ 20 kPa) ± (0.5 × 20 / X)% F.S. (20k Pa ≥ X ≥ 2.0 kPa)	
-------------	---	--

Zero temperature effect per 30°C *1	G2 external thread	± (4.7 × 40 / X + 0.35)%
-------------------------------------	--------------------	--------------------------

Model PTG60B- _4

Accuracy *1	± 0.5% F.S. (400 kPa ≥ X ≥ 80 kPa) ± (0.5 × 80 / X)% F.S. (80 kPa ≥ X ≥ 40 kPa)	
-------------	--	--

Zero temperature effect per 30°C *1	G2 external thread	± (2.5 × 80 / X + 0.35)%
-------------------------------------	--------------------	--------------------------

Model PTG60B- _5

Accuracy *1	± 0.5% F.S. (2 MPa ≥ X ≥ 0.4 MPa) ± (0.5 × 0.4 / X)% F.S. (0.4 MPa ≥ X ≥ 0.2 MPa)	
-------------	--	--

Zero temperature effect per 30°C *1	G2 external thread	± (0.82 × 0.4 / X + 0.35)%
	G1/2 external thread	± (10.8 × 0.4 / X + 0.35)%

Model PTG60B- _6

Accuracy *1	± 0.5% F.S. (10.0 MPa ≥ X ≥ 2.0 MPa) ± (0.5 × 2.0 / X)% F.S. (2.0 MPa ≥ X ≥ 1.0 MPa)	
-------------	---	--

Zero temperature effect per 30°C *1	G2 external thread	± (0.49 × 2.0 / X + 0.35)%
	G1/2 external thread	± (2.48 × 2.0 / X + 0.35)%

Note) *1: Within a range of URV ≥ 0 and LRV ≥ 0

Ambient temperature limits

Normal operating ranges

Fill fluid	G2 external thread	G1/2 external thread
Silicone oil	-10 to 50°C	-10 to 50°C
Propylene glycol	-10 to 50°C	-10 to 50°C

Transportation and storage temperatures

Fill fluid	G2 external thread	G1/2 external thread
Silicone oil	-20 to 60°C	-20 to 60°C
Propylene glycol	-20 to 60°C	-20 to 60°C

Temperature ranges of wetted parts

Fill fluid	G2 external thread	G1/2 external thread
Silicone oil	-10 to 85°C	-10 to 85°C
Propylene glycol	-10 to 85°C	-10 to 85°C

Ambient humidity limits

5 to 100% RH

Materials

Fill fluid

- Silicone oil
- Propylene glycol

Wetted parts

Diaphragm
SUS316L

Others
SUS316

Case

Aluminum alloy

Weight

- G2 inch external thread: Approx. 2.5 kg
- G1/2 inch external thread: Approx. 1.5 kg

Process connection

- G2 inch external thread
- G1/2 inch external thread

MODEL SELECTION**Smart pressure transmitter model PTG60B**

Process connection: Flush diaphragm type (G2 inch external, G1/2 inch external / flush diaphragm)

Measuring span: 2.0 to 100 kPa, 40 to 400 kPa, 0.2 to 2 MPa, 1 to 10 MPa

Model number structure: Basic model number - Selection - Option 1 - Option 2

Basic model number		PTG60B	Selection				Option1	Option2
Product description	Gauge pressure transmitter: Screw connection type (flush)	PTG60B	-					
Type of protection	Water and dust proof: IEC IP67 Electrical conduit: G1/2		G					
Measuring span	2.0 to 100 kPa (0.021 to 1.019 kgf/cm ²) (Not applicable for process connection G1/2)			3				
	40 to 400 kPa (0.408 to 4.07 kgf/cm ²) (Not applicable for process connection G1/2)			4				
	0.2 to 2 MPa (2.04 to 20.3 kgf/cm ²)			5				
	1 to 10 MPa (10.20 to 101.9 kgf/cm ²)			6				
Material: Diaphragm / wetted parts other than diaphragm /fill fluid	SUS316L / SUS316L / Silicone oil				C1			
	SUS316L / SUS316L / Propylene glycol				CB			
Process connection	G2 external thread					AGF		
	G1/2 external thread					AG4		
Option 1						-		
No option							X	
Built-in digital indicator							M	
Heavy duty corrosion-proof coating							B	
Remote communication function							C	
Wetted parts finish	Oil free finish						G	
	Water and oil free finish						H	
Option2						-		
No option							X	
Test report							1	
Material certificate							2	
Documents conforming to Japanese high pressure gas control law							3	
Over-pressure leak test							4	
Strength calculation sheet (JIS)							5	
Traceability certificate							6	
Mounting bracket							H	
Certificate of oil free finish							J	

DIMENSIONS

[Unit: mm]

Materials of construction

KEY No.	Description	Materials
1	Case	Aluminum alloy
2	Body	SUS 316 (Diaphragm SUS 316L)
3	Wetted Part	SUS 316L

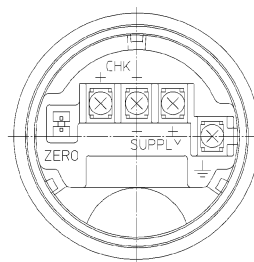

Terminal Connection
(M4 Screw)
See Table 3

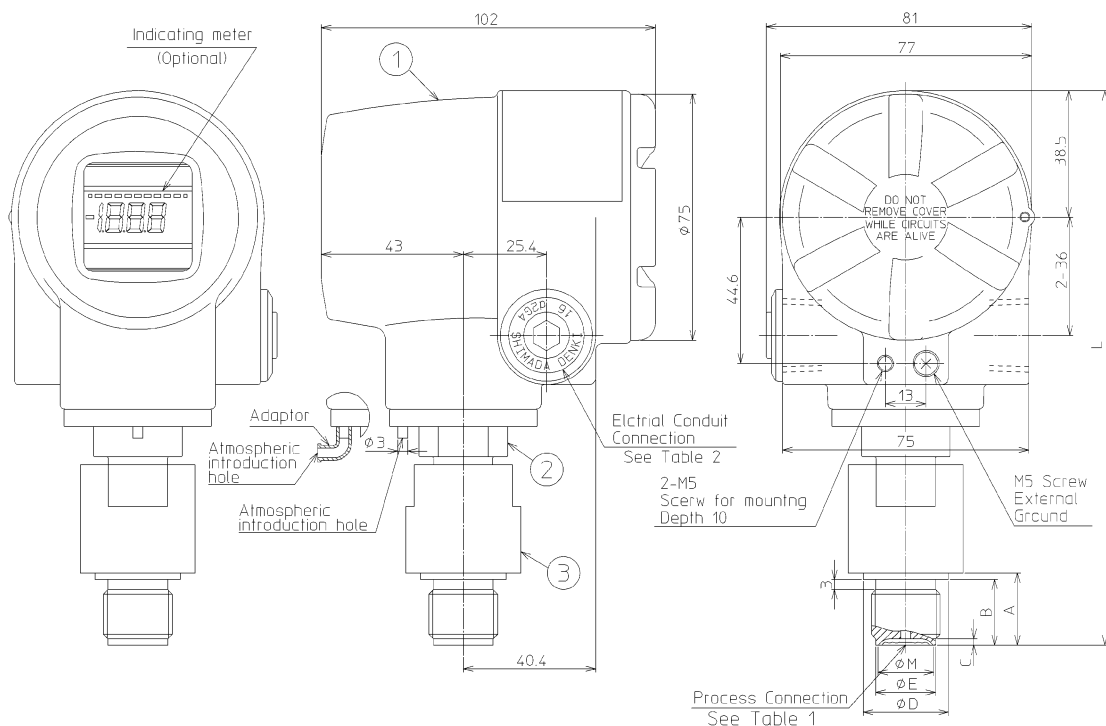

Table1 (See Inst. spec.)

Fitting	Mode No.		Thread Type of Process Connection (G)	A	B	φD	C	φE	φM	L
	Thread Type	Thread Size								
A	G	4	G 1/2 External	22	20	26	2	18.2	17	Approx 172
		F	G 2 External	30	—	—	—	—	43	Approx 180

Table2 (See Inst. spec.)

Mode No.	Electrical Conduit Connection
A, B	G 1/2 Internal
N, D, L	1/2NPT Internal

Table3 Terminal

Symbol	Terminal
SUPPLY +, SUPPLY -	Power supply and output signal
CHK+, CHK-	Check meter
⊥	Ground
ZERO	ZERO Adjuster

Flange type

(1/2 inch, 2 inches)

**Measuring Span / Setting Range / Max. Working Pressure**

Model number	Measuring span	Setting range	Max. working pressure	Process connection
PTG60F- _3	2.0 to 100 kPa	-100 to 100 kPa	200 kPa	2 inches (50 mm), 1/2 inch (15 mm)
PTG60F- _4	40 to 400 kPa	-100 to 400 kPa	800 kPa	
PTG60F- _5	0.2 to 2 MPa	-0.1 to 2 MPa	4 MPa or flange rating	
PTG60F- _6	1 to 10 MPa	-0.1 to 10 MPa	20 MPa or flange rating	

Accuracy / Temperature effect**Model PTG60F- _3**

Accuracy *1	$\pm 0.5\%$ F.S. (100 kPa $\geq X \geq 20$ kPa) $\pm (0.5 \times 2.0 / X)\%$ F.S. (20 kPa $> X > 2$ kPa)
-------------	---

Zero temperature effect per 30°C *1	2 inches (50 mm)	$\pm (4.5 \times 40 / X + 0.35)\%$
	1/2 inch (15 mm)	$\pm (10.0 \times 40 / X + 0.35)\%$

Model PTG60F- _4

Accuracy *1	$\pm 0.5\%$ F.S. (400 kPa $\geq X \geq 80$ kPa) $\pm (0.5 \times 80 / X)\%$ F.S. (80 kPa $\geq X \geq 40$ kPa)
-------------	---

Zero temperature effect per 30°C *1	2 inches (50 mm)	$\pm (2.4 \times 80 / X + 0.35)\%$
	1/2 inch (15 mm)	$\pm (7.1 \times 80 / X + 0.35)\%$

Model PTG60F- _5

Accuracy *1	$\pm 0.5\%$ F.S. (2MPa $\geq X \geq 0.4$ MPa) $\pm (0.5 \times 0.4 / X)\%$ F.S. (0.4MPa $\geq X \geq 0.2$ MPa)
-------------	---

Zero temperature effect per 30°C *1	2 inches (50 mm)	$\pm (0.8 \times 0.4 / X + 0.35)\%$
	1/2 inch (15 mm)	$\pm (1.4 \times 0.4 / X + 0.35)\%$

Model PTG60F- _6

Accuracy *1	$\pm 0.5\%$ F.S. (10.0 MPa $> X > 2.0$ MPa) $\pm (0.5 \times 2.0 / X)\%$ F.S. (2.0 MPa $> X > 1.0$ MPa)
-------------	--

Zero temperature effect per 30°C *1	2 inches (50 mm)	$\pm (0.5 \times 2.0 / X + 0.35)\%$
	1/2 inch (15 mm)	$\pm (0.5 \times 2.0 / X + 0.35)\%$

(Note) *1: Within a range of URV ≥ 0 and LRV ≥ 0 **Ambient temperature limits****Normal operating range**

Silicone oil -25 to 70°C

Propylene glycol -10 to 70°C

Transportation and storage temperature

Silicone oil -30 to 80°C

Propylene glycol -30 to 80°C

Temperature ranges of wetted parts

Silicone oil -40 to 110°C

Propylene glycol -10 to 110°C

150°C for 30 minutes during steam cleaning.

Ambient humidity limits

5 to 100% RH

Materials**Fill fluid**

- Silicone oil
- Propylene glycol

Wetted parts**Diaphragm**

SUS316L

Others

SUS316

Flange parts

SUS316L

SUS304 (JIS10K)

Case

Aluminum alloy

Weight

ANSI 150, 2 inches type: Approx. 4.2 kg

ANSI 150, 1/2 inch type: Approx. 2 kg

Process connection

- JIS10K 15 mm, 50 mm
- JIS30K 15 mm, 50 mm
- JPI/ ANSI 150 1/2 inch, 2 inches
- JPI/ ANSI 300 1/2 inch, 2 inches
- JPI/ ANSI 600 1/2 inch, 2 inches

MODEL SELECTION

Smart pressure transmitter model PTG60F

Process connection: Flange type

Measuring span: 2.0 to 100 kPa, 40 to 400 kPa, 0.2 to 2 MPa, 1 to 10 MPa

Model number structure: Basic model number - Selection - Option1 - Option2

Basic model number		Selection							Option1	Option2
PTG60F		-								
Product description	Gauge pressure transmitter: Flange mount type	PTG60F								
Type of protection	Water and dust proof: IEC IP67 Electrical conduit: G1/2	G								
Measuring span	2.0 to 100 kPa (0.021 to 1.019 kgf/cm ²)	3								
	40 to 400 kPa (0.408 to 4.07 kgf/cm ²)	4								
	0.2 to 2 MPa (2.04 to 20.3 kgf/cm ²)	5								
	1 to 10 MPa (10.20 to 101.9 kgf/cm ²)	6								
Material Diaphragm / wetted parts other than dia- phragm/fill fluid	SUS316L / SUS316L / Silicone oil	C1								
	SUS316L/SUS316L/Propylene glycol	CB								
Flange standard/rating	JIS 10K *2	A								
	JIS 30K *1 *2	D								
	ANSI 150	G								
	ANSI 300	H								
	ANSI 600	J								
	JPI 150	N								
	JPI 300	P								
	JPI 600	Q								
Flange diameter	2 inches / 50 mm	3								
	1 inch / 25 mm *3	5								
	1/2 inch / 15 mm	7								
Flange material	SUS316L	B								
	SUS304 *2	S								
Flange extension	None	X								
Option 1									-	
No option									X	
Built-in digital indicator									M	
Heavy duty corrosion-proof coating									B	
Remote communication function									C	
Wetted parts finish	Oil free finish								G	
	Water and oil free finish								H	
Option2									-	
No option									X	
Test report									1	
Material certificate									2	
Documents conforming to Japanese high pressure gas control law									3	
Over-pressure leak test									4	
Strength calculation sheet (JIS)									5	
Traceability certificate									6	
Mounting bracket									H	

Note) *1 Flange rating JIS 20K cannot be selected with flange size 2 inches / 50 mm.

*2 Flange material SUS304 must be selected for flange rating JIS 10K or JIS 20K

*3 Flange size 1 inch / 25 mm is applicable only with flange rating JIS 20K

DIMENSIONS

[Unit: mm]

Materials of construction

KEY No.	Description	Materials
1	Case	Aluminum alloy
2	Body	SUS 316
3	Wetted Part	SUS 316L

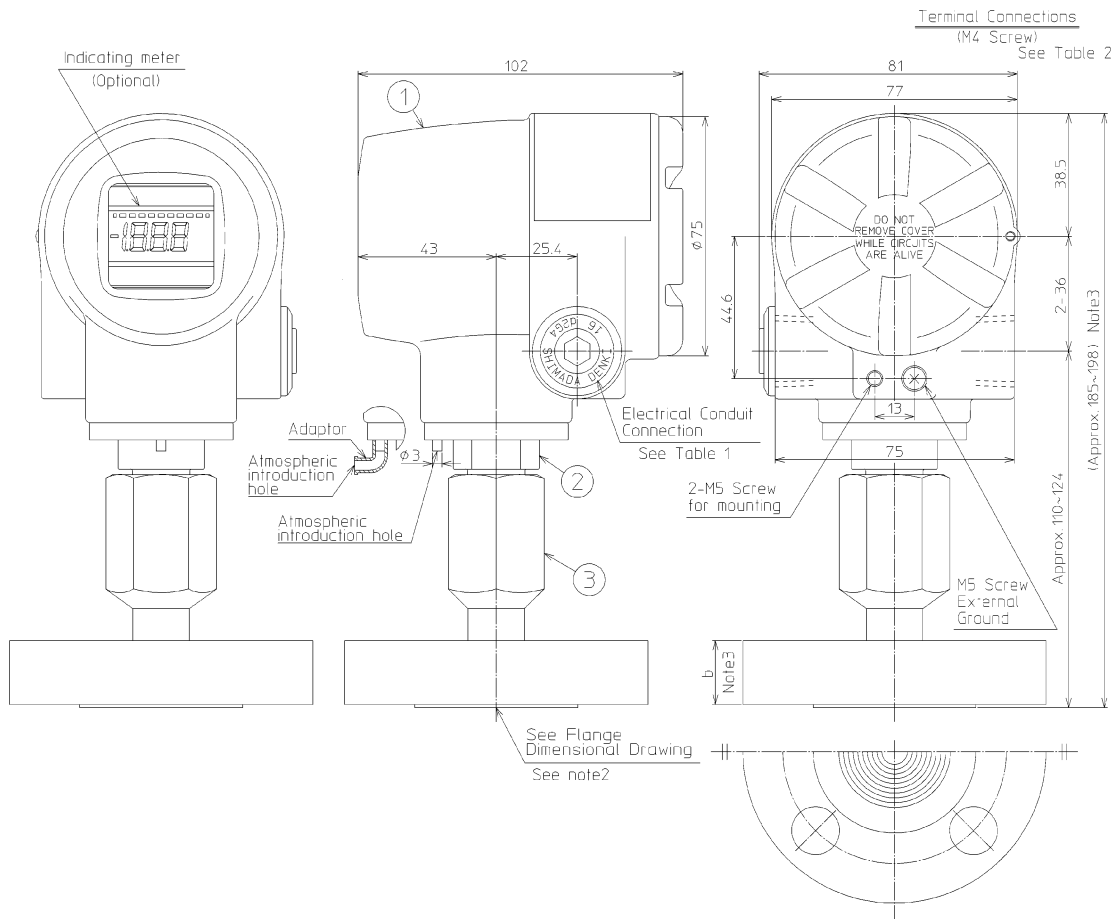
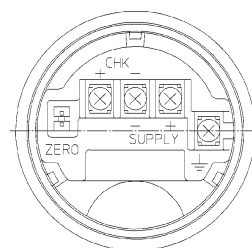

Table1 (See Inst. spec.)

Model No.	Electrical Conduit Connection
A, B	G 1/2 Internal
N, D, L	1/2 NPT Internal

Table2 Terminal

Symbol	Terminal
SUPPLY +, SUPPLY -	Power supply and output signal
CHK +, CHK -	Check meter
⏏	Ground
ZERO	ZERO Adjuster

- Note) 1. See Table 1.
 2. See flange dimensions on proceeding pages.
 3. See flange dimensions on proceeding pages.
 4. Do not loosen. Loosening the flange can cause fill fluid leakage.

JIS 10K - 15 mm / 25 mm

JIS 10K - 50 mm

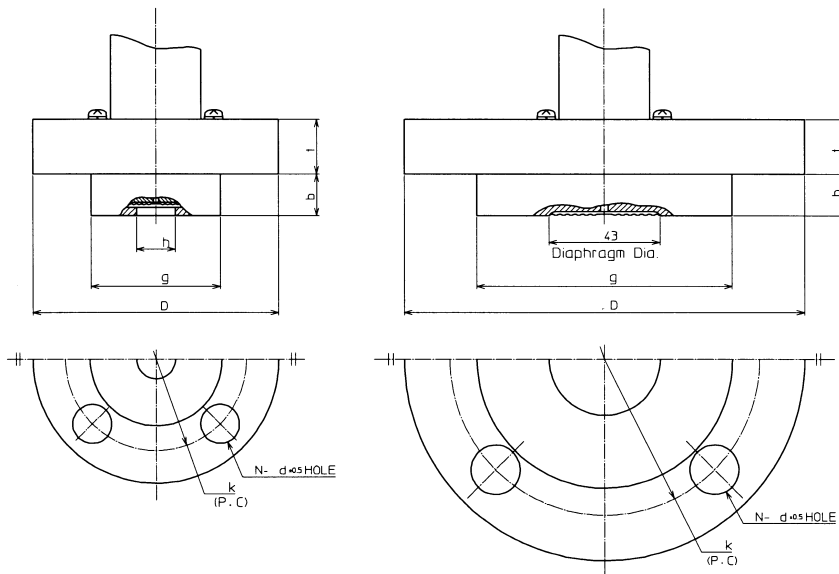

Flange rating	D_0^{-1}	g	k	N	$d_{\pm 0.5}$	1^{+1}	h	b
JIS 10K - 15 mm	95	54	70	4	15	12	15	16
JIS 10K - 50 mm	155	99	120	4	19	16	-	19

JIS 30K - 50mm, ANSI/ JPI - 2 inches

JIS 30K - 15 mm, ANSI/ JPI - 1/2 inch

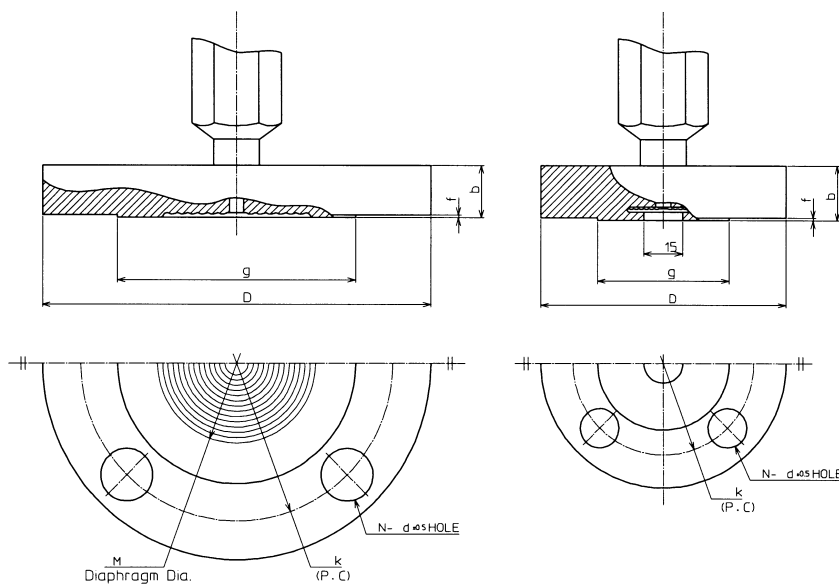

Flange rating	D^{-1}	g	k	N	$d_{\pm 0.5}$	M	b^{+1}	f
JIS 30K - 15 mm	115	55	80	4	19	-	21	1
ANSI/JPI 150 - 1/2 inch	90	35	60.5	4	16	-	22	2
ANSI/JPI 300 - 1/2 inch	95	35	66.5	4	16	-	22	2
ANSI/JPI 600 - 1/2 inch	95	35	66.5	4	16	-	27	7
JIS 30K - 50 mm	165	105	130	8	19	59	22	2
ANSI/JPI 150 - 2 inches	150	92	120.5	4	20	59	20	2
ANSI/JPI 300 - 2 inches	165	92	127	8	20	59	22.5	2
ANSI/JPI 600 - 2 inches	165	92	127	8	20	59	32.5	7

Ferrule type

(1S, 1½S, 2S clamp type)

**Measuring span / Setting range / Max. working pressure**

Model number	Measuring span	Setting range	Max. working pressure	Process connection
PTG60S- _3	2.0 to 100 kPa	-100 to 100 kPa	200 kPa	2S, 1½S
PTG60S- _4	40 to 400 kPa	-100 to 400 kPa	800 kPa or clamp rating	2S, 1½S, 1S
PTG60S- _5	0.2 to 2 MPa	-0.1 to 2 MPa	4 MPa or clamp rating	

Accuracy / Max. working pressure**Model PTG60S- _3**

Accuracy *1	± 0.5% F.S. (100 kPa ≥ X ≥ 20 kPa) ± (0.5 × 20 / X)% F.S. (20 kPa ≥ X ≥ 2 kPa)	
Zero temperature effect per 30°C *1	2S (Clamp type)	± (2.4 × 40 / X + 0.35)%
	1½S (Clamp type)	± (5.7 × 40 / X + 0.35)%

Model PTG60S- _4

Accuracy *1	± 0.5% F.S. (400 kPa ≥ X ≥ 80 kPa) ± (0.5 × 80 / X)% F.S. (80 kPa ≥ X ≥ 40 kPa)	
Zero temperature effect per 30°C *1	2S (Clamp type)	± (1.3 × 80 / X + 0.35)%
	1½S (Clamp type)	± (3.0 × 80 / X + 0.35)%
	1S (Clamp type)	± (30.4 × 80 / X + 0.35)%

Model PTG60S- _5

Accuracy *1	± 0.5% F.S. (2 MPa ≥ X ≥ 0.4 MPa) ± (0.5 × 0.4 / X)% F.S. (0.4 MPa ≥ X ≥ 0.2 MPa)	
Zero temperature effect per 30°C *1	2S (Clamp type)	± (0.58 × 0.4 / X + 0.35)%
	1½S (Clamp type)	± (0.92 × 0.4 / X + 0.35)%
	1S (Clamp type)	± (6.4 × 0.4 / X + 0.35)%

Note) *1: Within a range of URV ≥ 0 and LRV ≥ 0

Ambient temperature limits**Normal operating range**

-10 to 70°C

Transportation and storage temperature

-30 to 80°C

Temperature ranges of wetted parts

-10 to 110°C

150°C for 30 minutes during steam cleaning

Ambient humidity limits

5 to 100% RH

Materials**Fill fluid**

Propylene glycol

Wetted parts**Diaphragm**

SUS316L

Others

SUS316

Case

Aluminum alloy

Weight

Approx 1.2 kg

Process connection

- IDF 1S clamp type
- IDF 1½S clamp type
- IDF 2S clamp type

MODEL SELECTION

Smart pressure transmitter model PTG60S

Process connection: Ferrule clamp type

Measuring span: 2.0 to 100 kPa, 40 to 400 kPa, 0.2 to 2 MPa

Model number structure: Basic model number - Selection - Option1 - Option2

Basic model number		Selection				Option1	Option2
Product description		Gauge pressure transmitter: Ferrule type with SFC communication	PTG60S				
Type of protection		Water and dust proof: IEC IP67 Electrical conduit: G1/2		G			
Measuring span		2.0 to 100 kPa (0.021 to 1.1019 kgf/cm ²) (Not applicable for process connection 1S.)		3			
		40 to 400 kPa (0.408 to 4.07 kgf/cm ²)		4			
		0.2 to 2 MPa (2.04 to 20.3 kgf/cm ²)		5			
Material: Diaphragm / wetted parts other than diaphragm/fill fluid		SUS316L / SUS316L / Propylene glycol		CB			
Process connection		IDF 1S ferrule clamp type			AH2X		
		IDF1½S ferrule clamp type			AH3X		
		IDF 2S ferrule clamp type			AH4X		
Option 1						-	
No option						X	
Built-in digital indicator						M	
Heavy duty corrosion-proof coating						B	
Remote communication function						C	
Wetted parts finish		Anti-dynamic pressure specification *1				F	
		Anti-pulsation specification *2				J	
		Oil free finish				G	
		Water and oil free finish				H	
		Electrolytic grinding				K	
		Passive state finish				W	
Option2						-	
No option						X	
Test report							1
Material certificate							2
Documents conforming to Japanese high pressure gas control law							3
Over-pressure leak test							4
Strength calculation sheet (JIS)							5
Traceability certificate							6
Mounting bracket							H
Certificate of oil free finish							J

Note) *1 Not applicable for ferrule size 1S. The temperature effect will be 3.5 times of the standard. Wetted parts temperature range is +10 to +90°C.

*2 Not applicable for ferrule size 1S. The accuracy will be 1.5 times and the temperature effect will be 3.5 times of the standard. Wetted parts temperature range is +10 to +45°C.

DIMENSIONS

[Unit: mm]

Materials of construction

KEY No.	Description	Materials
1	Case	Aluminum alloy
2	Body	SUS 316
3	Ferrule	SUS 316L (Diaphragm SUS 316L)

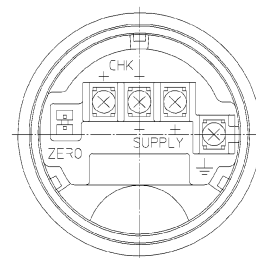

Terminal Connections
(M4 Screw)
See Table 3

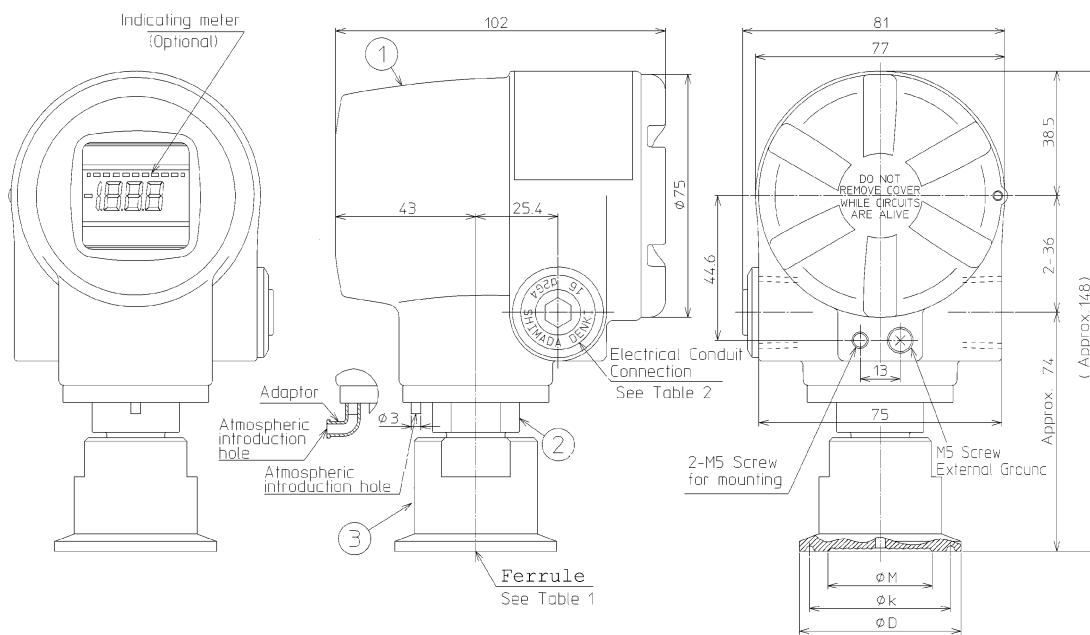

Table1 (See Inst. spec.)

Rating	Fitting	Model No.		D	φk	φM
		Size	Ferrule size			
A	H	2	IDF 1S	50.5	43.5	22
		3	IDF 15S			28
		4	IDF 2S			43

Table2 (See Inst. spec.)

Model No.	Electrical Conduit Connection
A, B	G 1/2 Internal
N, D, L	1/2 NPT Internal

Table3 Terminal

Symbol	Terminal
SUPPLY +, SUPPLY -	Power supply and output signal
CHK+, CHK-	Check meter
⊥	Ground
ZERO	ZERO Adjuster

Ferrule type

(1½ inch, 2 inches cap nut type)



Measuring Span / Setting Range / Max. Working Pressure

Model number	Measuring span	Setting range	Max. working pressure	Process connection
PTG60S -_3	2.0 to 100 kPa	-100 to 100 kPa	200 kPa	2S, 1½S
PTG60S -_4	40 to 400 kPa	-100 to 400 kPa	800 kPa or cap nut rating	
PTG60S -_5	0.2 to 2 MPa	-0.1 to 2 MPa	4 MPa or cap nut rating	

Accuracy / Max. working pressure

Model PTG60S- _3

Accuracy *1	± 0.5% F.S. (100 kPa ≥ X ≥ 20 kPa) ± (0.5 × 20 / X)% F.S. (20 kPa ≥ X ≥ 2 kPa)	
Zero temperature effect per 30°C *1	2S (Cap nut type)	± (2.4 × 40 / X + 0.35)%
	1½S (Cap nut type)	± (5.7 × 40 / X + 0.35)%

Model PTG60S- _4

Accuracy *1	± 0.5% F.S. (400 kPa ≥ X ≥ 80k Pa) ± (0.5 × 80 / X)% F.S. (80 kPa ≥ X ≥ 40 kPa)	
Zero temperature effect per 30°C *1	2S (Cap nut type)	± (1.3 × 80 / X + 0.35)%
	1½S (Cap nut type)	± (3.0 × 80 / X + 0.35)%

Model PTG60S- _5

Accuracy *1	± 0.5% F.S. (2 MPa ≥ X ≥ 0.4 MPa) ± (0.5 × 0.4 / X)% F.S. (0.4 MPa ≥ X ≥ 0.2M Pa)	
Zero temperature effect per 30°C *1	2S (Cap nut type)	± (0.58 × 0.4 / X + 0.35)%
	1½S (Cap nut type)	± (0.92 × 0.4 / X + 0.35)%

Note) *1: Within a range of URV ≥ 0 and LRV ≥ 0

Ambient temperature limits

Normal operating range

-10 to 70°C

Transportation and storage temperature

-30 to 80°C

Temperature range of wetted parts

-10 to 110°C

150°C within 30 minutes of steam cleaning

Ambient humidity limits

5 to 100% RH

Materials

Fill fluid

Propylene glycol

Wetted parts

Diaphragm

SUS316L

Others

SUS316

Case

Aluminum alloy

Weight

- 1½ inch : Approx. 1.4 kg
- 2 inches : Approx. 1.7 kg

Process connection

- IDF 1½S cap nut type
- IDF 2S cap nut type

MODEL SELECTION

Smart pressure transmitter model PTG60S

Process connection: Ferrule cap nut type

Measuring span: 2.0 to 100 kPa, 40 to 400 kPa, 0.2 to 2 MPa

Model number structure: Basic model number - Selection - Option1 - Option2

		PTG60S	Selection				Option1	Option2
Product Description	Gauge pressure transmitter: Ferrule type	PTG60S	-					
Type of protection	Water and dust proof: IEC IP67 Electrical conduit: G1/2		G					
Measuring span	2.0 to 100 kPa (0.021 to 1.1019 kgf/cm ²)			3				
	40 to 400 kPa (0.408 to 4.07 kgf/cm ²)			4				
	0.2 to 2 MPa (2.04 to 20.3 kgf/cm ²)			5				
Material: Diaphragm / wetted parts other than diaphragm/fill fluid	SUS316L / SUS316L / Propylene glycol				CB			
Process connection	IDF 1½S ferrule cap nut type							
	IDF 2S ferrule cap nut type							
Option 1							-	
No option								X
Built-in digital indicator								M
Heavy duty corrosion-proof coating								B
Remote communication function								C
Wetted parts finish	Anti-dynamic pressure specification *1							F
	Anti-pulsaion specification *2							J
	Oil free finish							G
	Water and oil free finish							H
	Electrolytic grinding							K
	Passive state finish							W
Option2							-	
No option								X
Test report								1
Material certificate								2
Documents conforming to Japanese high pressure gas control law								3
Over-pressure leak test								4
Strength calculation sheet (JIS)								5
Traceability certificate								6
Mounting bracket								H
Certificate of oil free finish								J

Note) *1 The temperature effect will be 3.5 times of the standard. Wetted parts temperature range is +10 to +90°C.

*2 Not applicable for ferrule size 1.5S. The accuracy will be 1.5 times and the temperature effect will be 3.5 times of the standard. Wetted parts temperature range is +10 to +45°C.

DIMENSIONS

[Unit: mm]

Materials of construction

KEY No.	Description	Materials
1	Case	Aluminum alloy
2	Body	SUS 316
3	Wetted Part	SUS 316L

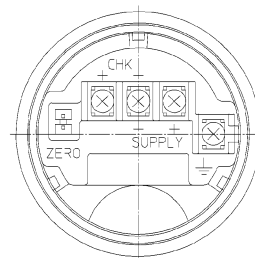

Terminal Connections
(M4 Screw)
See Table 3

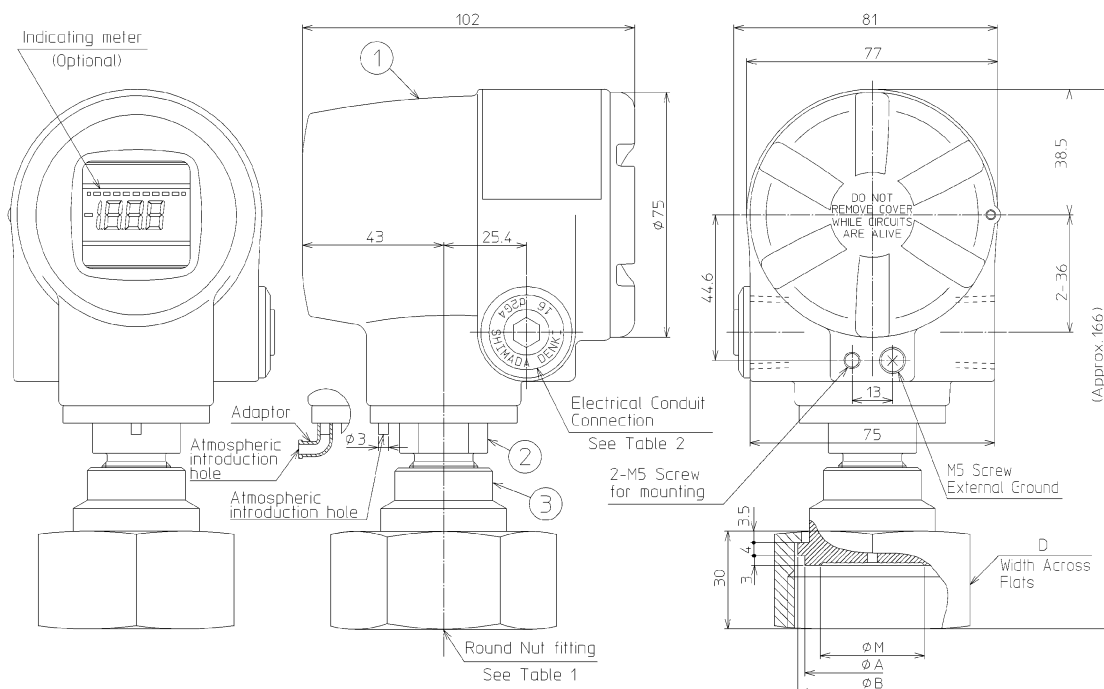

Table1 (See Inst. spec.)

Model No.	Fitting Size	D	ØM	A	B
Rating	Fitting Size				
A	3 IDF 15S	60	28	42.7	47
	4 IDF 2S	75	43	56.2	60.5

Table2 (See Inst. spec.)

Model No.	Electrical Conduit Connection
A, B	G 1/2 Internal
N, D, L	1/2 NPT Internal

Table3 Terminal

Symbol	Terminal
SUPPLY +, SUPPLY -	Power supply and output signal
CHK+, CHK-	Check meter
⊥	Ground
ZERO	ZERO Adjuster

Ferrule with cooling tower (1 inch, 1 1/2 inch, 2 inches clamp type)



Measuring span / Setting range / Max. working pressure

Model number	Measuring span	Setting range	Max. working pressure	Process connection
PTG60K- _3	2.0 to 100 kPa	-100 to 100 kPa	200 kPa	2, 1 1/2S
PTG60K- _4	40 to 400 kPa	-100 to 400 kPa	800 kPa or clamp rating	2S, 1 1/2S, 1S
PTG60K- _5	0.2 to 2 MPa	-0.1 to 2 MPa	4 MPa or clamp rating	

Accuracy / Temperature effect

Model PTG60K- _3

Accuracy *1	± 0.5% F.S. (100 kPa ≥ X ≥ 20 kPa) ± (0.5 × 20 / X)% F.S. (20 kPa ≥ X ≥ 2 kPa)	
Zero temperature effect per 30°C *1	2S (Clamp type)	± (2.5 × 40 / X + 0.35)%
	1 1/2S (Clamp type)	± (8.5 × 40 / X + 0.35)%

Model PTG60K- _4

Accuracy *1	± 0.5% F.S. (400 kPa > X > 80 kPa) ± (0.5 × 80 / X)% F.S. (80 kPa > X > 40 kPa)	
Zero temperature effect per 30°C *1	2S (Clamp type)	± (1.4 × 80 / X + 0.35)%
	1 1/2S (Clamp type)	± (4.4 × 80 / X + 0.35)%
	1S (Clamp type)	± (37.5 × 80 / X + 0.35)%

Model PTG60K- _5

Accuracy *1	± 0.5% F.S. (2 MPa > X > 0.4 MPa) ± (0.5 × 0.4 / X)% F.S. (0.4 MPa > X > 0.2 MPa)	
Zero temperature effect per 30°C *1	2S (Clamp type)	± (0.6 × 0.4 / X + 0.35)%
	1 1/2S (Clamp type)	± (1.2 × 0.4 / X + 0.35)%
	1S (Clamp type)	± (7.8 × 0.4 / X + 0.35)%

Note) *1: Within a range of URV ≥ 0 and LRV ≥ 0

Ambient temperature limits

Normal operating range

-10 to 70°C

Transportation and storage temperature

-30 to 80°C

Temperature range of wetted parts

-10 to 150°C

Ambient humidity limit

5 to 100% RH

Materials

Fill fluid

Propylene glycol

Wetted parts

Diaphragm

SUS316L

Others

SUS316

Case

Aluminum alloy

Weight

Approx. 1.4 kg

Process connection

- IDF 1S clamp
- IDF 1 1/2S clamp
- IDF 2S clamp

MODEL SELECTION

Smart pressure transmitter model PTG60K

Process connection: Ferrule clamp type with cooling tower

Measuring span: 2.0 to 100 kPa, 40 to 400 kPa, 0.2 to 2 MPa

Model number structure: Basic model number - Selection - Option1 - Option2

Basic model number		PTG60K	-	Selection			-	Option1	-	Option2
Product description	Gauge pressure transmitter: Ferrule type with cooling tower	PTG60K	-							
Type of protection	Water and dust proof: IEC IP67 Electrical conduit: G1/2		G							
Measuring span	2.0 to 100 kPa (0.021 to 1.019 kgf/cm ²) (Not applicable for ferrule size 1S)			3						
	40 to 400 kPa (0.408 to 4.07 kgf/cm ²)			4						
	0.2 to 2MPa (2.04 to 20.3 kgf/cm ²)			5						
Material: Diaphragm / wetted parts other than diaphragm/fill fluid	SUS316L / SUS316L / Propylene glycol					CB				
Process connection	IDF 1S ferrule clamp type (Not applicable for span code "3")									
	IDF 1½S ferrule clamp type						AH2X			
	IDF 2S ferrule clamp type						AH3X			
Option 1							-			
No option								X		
Built-in digital indicator								M		
Heavy duty corrosion-proof coating								B		
Remote communication function								C		
Wetted parts finish	Oil free finish							G		
	Water and oil free finish							H		
	Electrolytic grinding							K		
	Passive state finish							W		
Option2							-			
No option										X
Test report										1
Material certificate										2
Documents conforming to Japanese high pressure gas control law										3
Over-pressure leak test										4
Strength calculation sheet (JIS)										5
Traceability certificate										6
Mounting bracket										H
Certificate of oil free finish										J

DIMENSIONS

[Unit: mm]

Materials of construction

KEY No.	Description	Materials
1	Case	Aluminum alloy
2	Body	SUS 316
3	Capillary A'ssy	SUS 316
4	Welded Part	SUS 316L

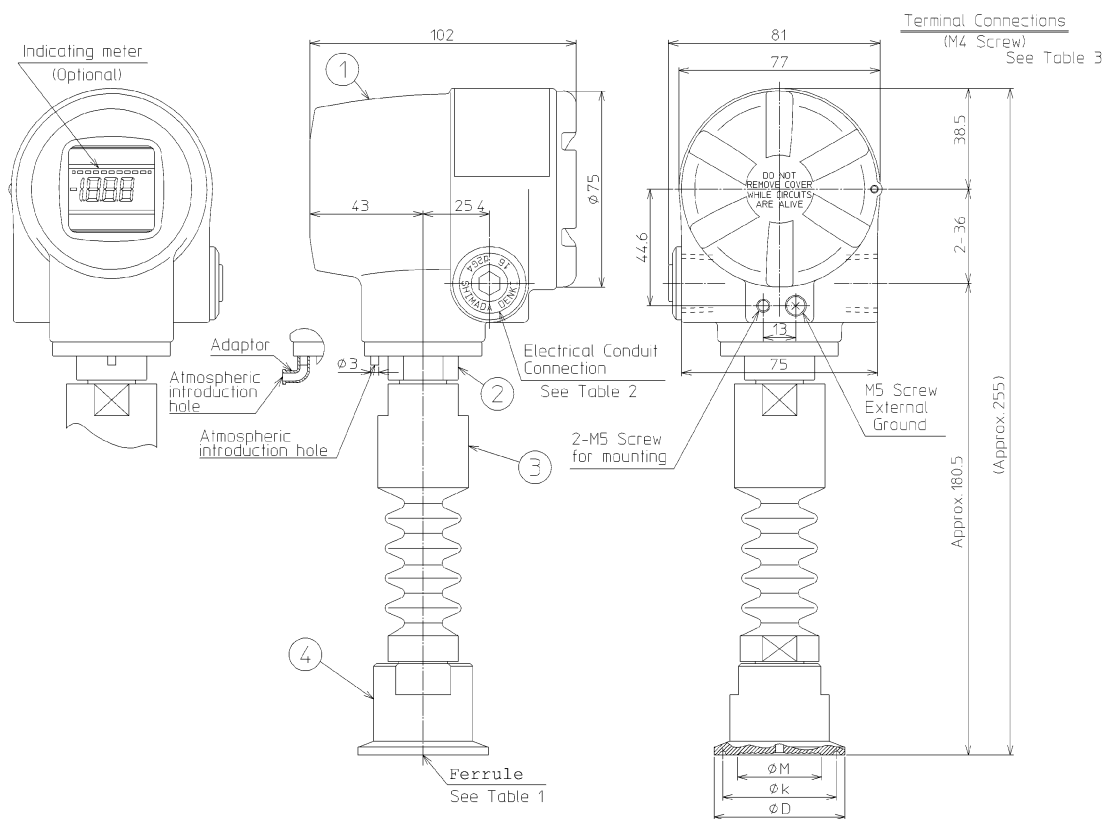
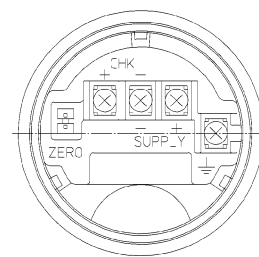

Table1 (See Inst. spec.)

Model No.		Ferrule Size		φD	φk	φM
Rating	Fitting Size					
A	H	2	IDF 1S	50.5	43.5	22
		3	IDF 15S			28
		4	IDF 2S	64	56.5	43

Table2 (See Inst. spec.)

Model No.	Electrical Conduit Connection
A, B	G 1/2 Internal
N, D, L	1/2 NPT Internal

Table3 Terminal

Symbol	Terminal
SUPPLY +, SUPPLY -	Power supply and output signal
CHK+, CHK-	Check meter
⊥	Ground
ZERO	ZERO Adjuster

Ferrule with cooling tower

(1½ inch, 2 inches cap nut type)



Measuring span/ Setting range/ Max. working pressure

Model number	Measuring span	Setting range	Max. working pressure	Process connection
PTG60K- <u>3</u>	2.0 to 100kPa	-100 to 100 kPa	200 kPa	2S, 1½S
PTG60K- <u>4</u>	40 to 400 kPa	-100 to 400 kPa	800 kPa or cap nut rating	
PTG60K- <u>5</u>	0.2 to 2 MPa	-0.1 to 2 MPa	4 MPa or cap nut rating	

Accuracy / Temperature effect

Model PTG60K-3

Accuracy *1	± 0.5% F.S. (100kPa ≥ X ≥ 20 kPa) ± (0.5 × 20 / X)% F.S. (20k Pa ≥ X ≥ 2 kPa)
-------------	--

Zero temperature effect per 30°C *1	2S (Cap nut type)	± (2.5 × 40 / X + 0.35)%
	1½S (Cap nut type)	± (8.5 × 40 / X + 0.35)%

Model PTG60K-4

Accuracy *1	± 0.5% F.S. (400 kPa ≥ X ≥ 80 kPa) ± (0.5 × 80 / X)% F.S. (80 kPa ≥ X ≥ 40 kPa)
-------------	--

Zero temperature effect per 30°C *1	2S (Cap nut type)	± (1.4 × 80 / X + 0.35)%
	1½S (Cap nut type)	± (4.4 × 80 / X + 0.35)%

Model PTG60K-5

Accuracy *1	± 0.5% F.S. (2 MPa ≥ X ≥ 0.4 MPa) ± (0.5 × 0.4 / X)% F.S. (0.4 MPa ≥ X ≥ 0.2 MPa)
-------------	--

Zero temperature effect per 30°C *1	2S (Cap nut type)	± (0.6 × 0.4 / X + 0.35)%
	1½S (Cap nut type)	± (1.2 × 0.4 / X + 0.35)%

Note) *1: Within a range of URV ≥ 0 and LRV ≥ 0

Ambient temperature limits

Normal operating range

-10 to 70°C

Transportation and storage temperature

-30 to 80°C

Temperature ranges of wetted parts

-10 to 150°C

Ambient humidity limits

5 to 100% RH

Materials

Fill fluid

Propylene glycol

Wetted parts

Diaphragm

SUS316L

Others

SUS316

Case

Aluminum alloy

Weight

- 1½ inch: Approx. 1.6 kg
- 2 inches: Approx. 1.9 kg

Process connection

- IDF 1½S cap nut type
- IDF 2S cap nut type

MODEL SELECTION**Smart pressure transmitter model PTG60K**

Process connection: Ferrule cap nut type with cooling tower

Measuring span 2.0 to 100 kPa, 40 to 400 kPa, 0.2 to 2 MPa

Model number structure: Basic model number - Selection - Option1 - Option2

Basic model number		PTG60K	-	Selection			-	Option1	-	Option2
Product description	Gauge pressure transmitter: Ferrule type with cooling tower with SFC communication	PTG60K	-							
Type of protection	Water and dust proof: IEC IP67 Electrical conduit: G1/2		G							
Measuring span	2.0 to 100 kPa (0.021 to 1.019 kgf/cm ²)			3						
	40 to 400 kPa (0.408 to 4.07 kgf/cm ²)			4						
	0.2 to 2 MPa (2.04 to 20.3 kgf/cm ²)			5						
Material: Diaphragm / wetted parts other than diaphragm/fill fluid	SUS316L / SUS316L / Propylene glycol					CB				
Process connection	IDF 1½S ferrule cap nut type						AC3X			
	IDF 2S ferrule cap nut type						AC4X			
Option 1								-		
No option									X	
Built-in digital indicator									M	
Heavy duty corrosion-proof coating									B	
Remote communication function									C	
Wetted parts finish	Oil free finish							G		
	Water and oil free finish							H		
	Electrolytic grinding							K		
	Passive state finish							W		
Option2										-
No option										X
Test report										1
Material certificate										2
Documents conforming to Japanese high pressure gas control law										3
Over-pressure leak test										4
Strength calculation sheet (JIS)										5
Traceability certificate										6
Mounting bracket										H
Certificate of oil free finish										J

DIMENSIONS

[Unit: mm]

Materials of construction

KEY No.	Description	Materials
1	Case	Aluminum alloy
2	Body	SUS 316
3	Capillary A'ssy	SUS 316
4	Welded Part	SUS 316L

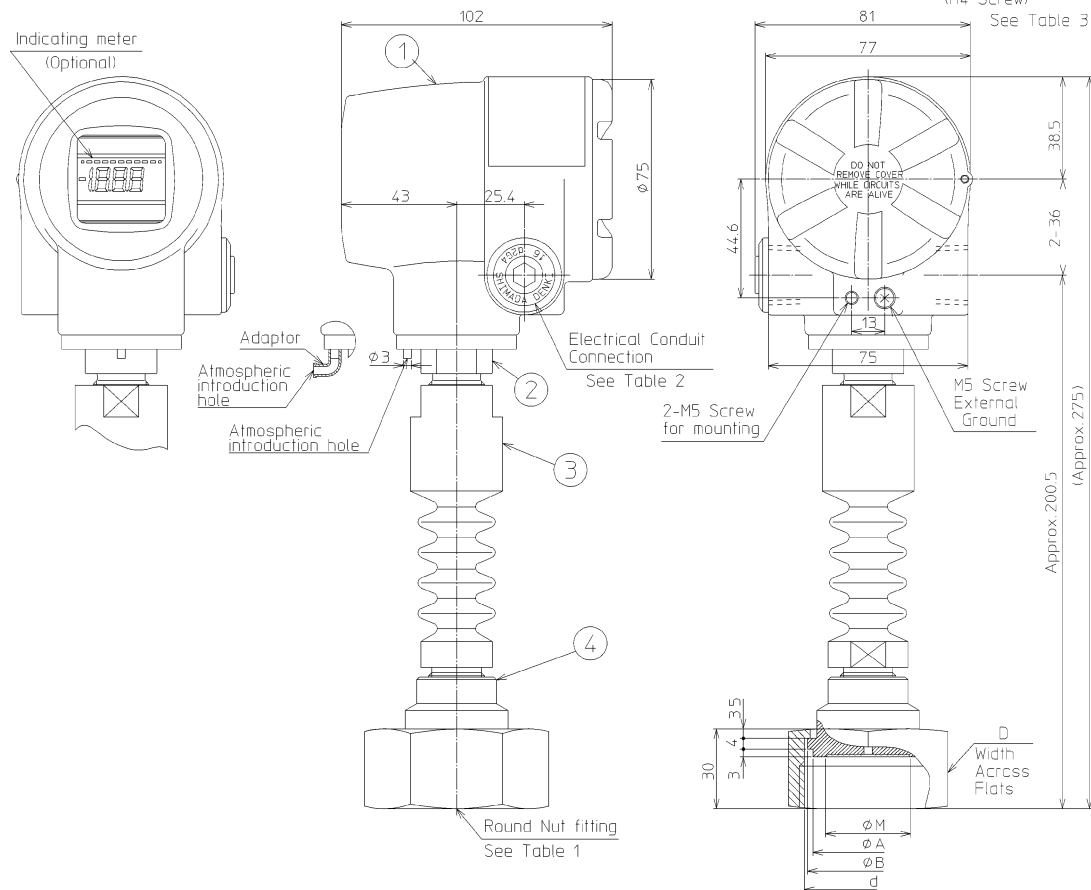

Table1 (See Inst. spec.)

Model No.	Fitting Size(d)	D	ϕM	A	B
Rating/Fitting Size					
A C	3 IDF 15S	60	28	42.7	47
	4 IDF 2S	75	43	56.2	60.5

Table2 (See Inst. spec.)

Model No.	Electrical Conduit Connection
A, B	G 1/2 Internal
N, D, L	1/2 NPT Internal

Table3 Terminal

Symbol	Terminal
SUPPLY +, SUPPLY -	Power supply and output signal
CHK+, CHK-	Check meter
\perp	Ground
ZERO	ZERO Adjuster

Remote seal with ferrule type

(1½ inch, 2 inches clamp type)

**Measuring span/ Setting range/ Max. working pressure**

Model number	Measuring span	Setting range	Max. working pressure	Process connection
PTG60T- _3	2.0 to 100 kPa	-100 to 100 kPa	200 kPa	2S
PTG60T- _4	40 to 400 kPa	-100 to 400 kPa	800 kPa or clamp rating	2S, 1½S
PTG60T- _5	0.2 to 2 MPa	-0.1 to 2 MPa	4 MPa or clamp rating	

Accuracy / Temperature effect**Model PTG60T- _3**

Accuracy *1	± 0.5% F.S. (100 kPa ≥ X ≥ 20 kPa) ± (0.5 × 20 / X)% F.S. (20 kPa ≥ X ≥ 2 kPa)
-------------	---

Zero temperature effect per 30°C *1	2S (Clamp type) ± (11.5 × 40 / X + 0.35)%
-------------------------------------	---

Model PTG60T- _4

Accuracy *1	± 0.5% F.S. (400 kPa ≥ X ≥ 80 kPa) ± (0.5 × 80 / X)% F.S. (80 kPa ≥ X ≥ 40 kPa)
-------------	--

Zero temperature effect per 30°C *1	2S (Clamp type) ± (5.9 × 80 / X + 0.35)%
	1½S (Clamp type) ± (21.7 × 80 / X + 0.35)%

Model PTG60T- _5

Accuracy *1	± 0.5% F.S. (2 MPa ≥ X ≥ 0.4 MPa) ± (0.5 × 0.4 / X)% F.S. (0.4 MPa ≥ X ≥ 0.2 MPa)
-------------	--

Zero temperature effect per 30°C *1	2S (Clamp type) ± (1.5 × 0.4 / X + 0.35)%
	1½S (Clamp type) ± (4.65 × 0.4 / X + 0.35)%

Note) *1: Within a range of URV ≥ 0 and LRV ≥ 0

Ambient temperature limits**Normal operating ranges**

1½ inch -5 to 55°C

2 inches -5 to 60°C

Transportation and storage temperature

-5 to 50°C

Temperature range of wetted parts

-5 to 110°C

150°C for 30 minutes during steam cleaning

Ambient humidity limits

5 to 100% RH

Materials**Fill fluid**

Propylene glycol

Wetted parts**Diaphragm**

SUS316L

Others

SUS316

Case

Aluminum alloy

Capillary cover

Olefin

Weight

Approx. 1.8 kg (Capillary length 3 m)

Process connection

- IDF 1½S clamp type
- IDF 2S clamp type

MODEL SELECTION

Smart pressure transmitter model PTG60T

Process connection: Remote seal with ferrule clamp type

Measuring span: 2.0 to 100 kPa, 40 to 400 kPa, 0.2 to 2 MPa

Model number structure: Basic model number - Selection - Option1 - Option2

		PTG60T	Selection				Option1	Option2
		PTG60T						
Product description	Gauge pressure transmitter: Ferrule type with remote seal with SFC Communication	PTG60T						
Type of protection	Water and dust proof: IEC IP67 Electrical conduit: G1/2		G					
Measuring span	2.0 to 100 kPa (0.021 to 1.019 kgf/cm ²) (Not applicable for process connection 1S)			3				
	40 to 400 kPa (0.408 to 4.07 kgf/cm ²)			4				
	0.2 to 2 MPa (2.04 to 20.3 kgf/cm ²)			5				
Material: Diaphragm / wetted parts other than diaphragm/fill fluid	SUS316L / SUS316 L / Propylene glycol				CB			
Process connection	IDF 1½S ferrule clamp type					AH3X		
	IDF 2S ferrule clamp type					AH4X		
Capillary length	1 m (with olefin tube)					E		
	3 m (with olefin tube)					G		
	5 m (with olefin tube)					J		
Option 1								
No option							X	
Built-in digital indicator							M	
Heavy duty corrosion-proof coating							B	
Remote communication function							C	
Wetted parts finish	Oil free finish						G	
	Water and oil free finish						H	
	Electrolytic grinding						K	
	Passive state finish						W	
Option2								
No option							X	
Test report							1	
Material certificate							2	
Documents conforming to Japanese high pressure gas control law							3	
Over-pressure leak test							4	
Strength calculation sheet (JIS)							5	
Traceability certificate							6	
Mounting bracket							H	
Certificate of oil free finish							J	

DIMENSIONS

[Unit: mm]

Materials of construction

KEY No.	Description	Materials
1	Case	Aluminum alloy
2	Body	SUS 316
3	Capillary A'ssy	SUS 304(Olefin cover)
4	Wetted Part	SUS 316L

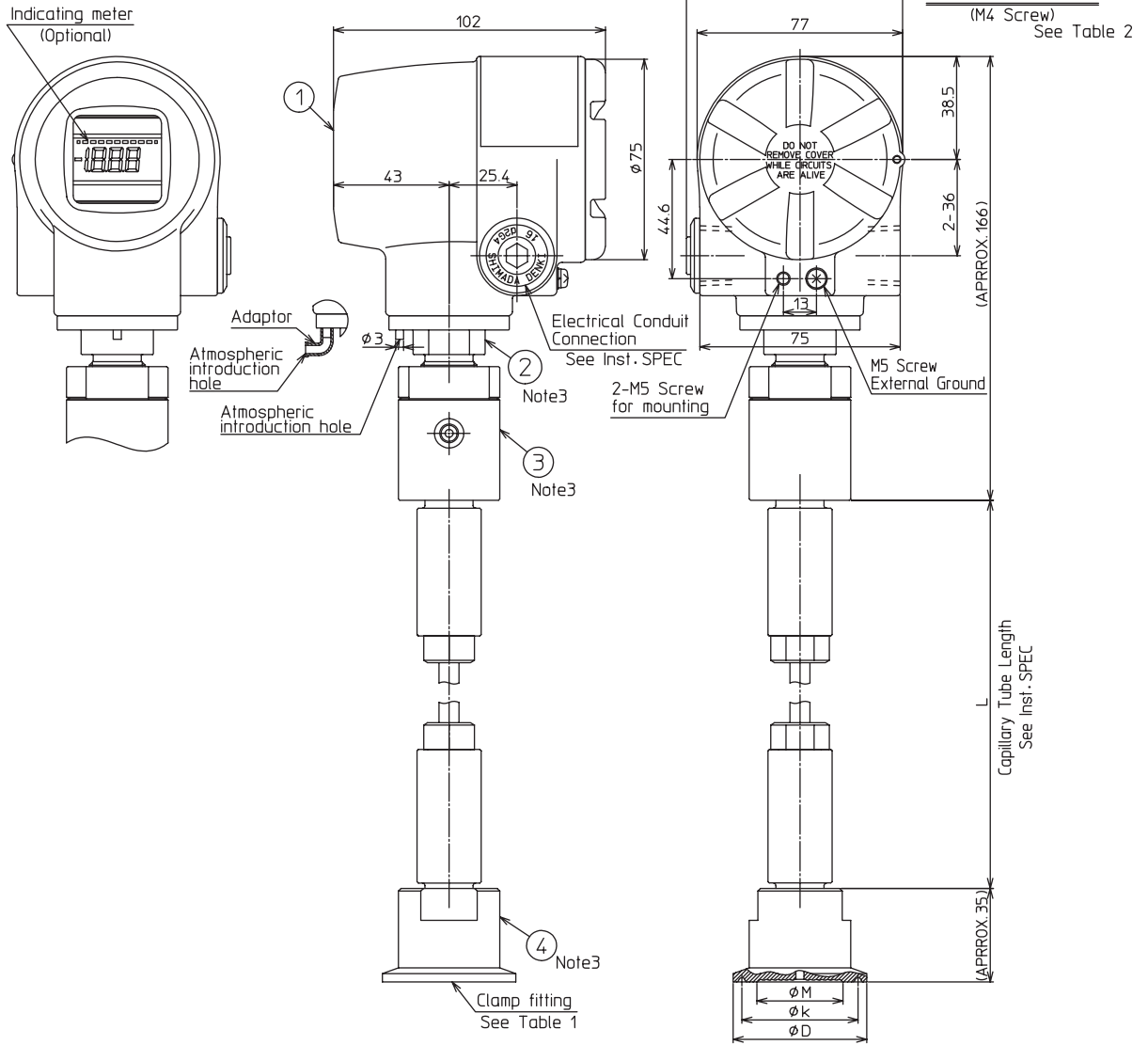

Table1 (See Inst. spec.)

Rating	Fitting	Model No.		Ferrule Size	φD	φk	φM
		Size	Size				
A	H	2	IDF 1S	50.5	43.5	22	
		3	IDF 1.5S	50.5	43.5	28	
		4	IDF 2S	64	56.5	43	

Table2 Terminal

Symbol	Terminal
SUPPLY +, SUPPLY -	Power supply and output signal
CHK +, CHK -	Check meter
⊥	Ground
ZERO	ZERO Adjuster

Remote seal with ferrule type

(1½ inch, 2 inches cap nut type)



Measuring span/ Setting range/ Max. working pressure

Model number	Measuring span	Setting range	Max. working pressure	Process connection
PTG60T- <u>3</u>	2.0 to 100 kPa	-100 to 100 kPa	200 kPa	2S
PTG60T- <u>4</u>	40 to 400 kPa	-100 to 400 kPa	800 kPa or cap nut rating	2S, 1½S
PTG60T- <u>5</u>	0.2 to 2 MPa	-0.1 to 2 MPa	4 MPa or cap nut rating	

Accuracy / Temperature effect

Model PTG60T-3

Accuracy *1	± 0.5% F.S. (100 kPa ≥ X ≥ 20 kPa) ± (0.5 × 20 / X)% F.S. (20 kPa ≥ X ≥ 2 kPa)
-------------	---

Zero temperature effect per 30°C *1	2S (Cap nut type) ± (11.5 × 40 / X + 0.35)%
-------------------------------------	---

Model PTG60T-4

Accuracy *1	± 0.5% F.S. (400 kPa ≥ X ≥ 80 kPa) ± (0.5 × 80 / X)% F.S. (80 kPa ≥ X ≥ 40 kPa)
-------------	--

Zero temperature effect per 30°C *1	2S (Cap nut type) ± (5.9 × 80 / X + 0.35)%
	1½S (Cap nut type) ± (21.7 × 80 / X + 0.35)%

Model PTG60T-5

Accuracy *1	± 0.5% F.S. (2 MPa > X > 0.4 MPa) ± (0.5 × 0.4 / X)% F.S. (0.4 MPa > X > 0.2 MPa)
-------------	--

Zero temperature effect per 30°C *1	2S (Cap nut type) ± (1.5 × 0.4 / X + 0.35)%
	1½S (Cap nut type) ± (4.65 × 0.4 / X + 0.35)%

Note) *1: Within a range of URV ≥ 0 and LRV ≥ 0

Ambient temperature limits

Normal operating range

-5 to 55°C

Transportation and storage temperature

-5 to 50°C

Temperature range of wetted parts

-5 to 110°C

150°C for 30 minutes during steam cleaning

Ambient humidity limits

5 to 100% RH

Materials

Fill fluid

Propylene glycol

Wetted parts

Diaphragm

SUS316L

Others

SUS316

Case

Aluminum alloy

Capillary cover

Olefin

Weight

Approx. 2.3 kg (Capillary length 3 m)

Process connection

- IDF 1½S cap nut type
- IDF 2S cap nut type

MODEL SELECTION**Smart pressure transmitter model PTG60T**

Process connection: Remote seal with ferrule cap nut type

Measuring span 2.0 to 100 kPa, 40 to 400 kPa, 0.2 to 2 MPa

Model number structure: Basic model number - Selection - Option1 - Option 2

		PTG60T	Selection				Option1	Option2
Product description	Gauge pressure transmitter: Ferrule type with remote seal with SFC communication	PTG60T						
Type of protection	Water and dust proof: IEC IP67 Electrical conduit: G1/2		G					
Measuring span	2.0 to 100 kPa (0.021 to 1.019 kgf/cm ²)			3				
	40 to 400 kPa (0.408 to 4.07 kgf/cm ²)			4				
	0.2 to 2 MPa (2.04 to 20.3 kgf/cm ²)			5				
Material: Diaphragm / wetted parts other than diaphragm/fill fluid	SUS316L / SUS316L / Propylene glycol				CB			
Process connection	IDF 1½S ferrule cap nut type					AC3X		
	IDF 2S ferrule cap nut type					AC4X		
Capillary length	1 m (with olefin tube)					E		
	3 m (with olefin tube)					G		
	5 m (with olefin tube)					J		
Option 1						-		
No option							X	
Heavy duty corrosion-proof coating							B	
Remote communication function							C	
Built-in digital indicator							M	
Wetted parts finish	Oil free finish					G		
	Water and oil free finish					H		
	Electrolytic grinding					K		
	Passive state finish					W		
Option2						-		
No option							X	
Test report							1	
Material certificate							2	
Documents conforming to Japanese high pressure gas control law							3	
Over-pressure leak test							4	
Strength calculation sheet (JIS)							5	
Traceability certificate							6	
Mounting bracket							H	
Certificate of oil free finish							J	

