

**Smart Pressure Transmitter
Model: PTG71/72**

User's Manual



Yamatake Corporation

Copyright, Notices and Trademarks

Printed in Japan - ©Copyright 1998 by Yamatake Corporation.

While this information is presented in good faith and believed to be accurate, Yamatake Corporation disclaims the implied warranties of merchantability and fitness for a particular purpose and makes no express warranties except as may be stated in its written agreement with and for its customer.

In no event is Yamatake Corporation liable to anyone for any indirect, special or consequential damages. This information and specifications in this document are subject to change without notice.

Preface

Thank you very much for purchasing Yamatake's PTG Series Smart Pressure Transmitter. Yamatake's PTG Series Smart Pressure Transmitters are high performance, highly reliable general use pressure transmitters. The PTG Series offer improved performance and reliability with size, weight and cost advantages. Information regarding the PTG Series can be accessed using handheld SFC (Smart Field Communicator) at the valve or at a field junction box, or by using operators console.

This instruction manual describes how to use the PTG Series Smart Pressure Transmitter. We hope that you will fully use this manual to make the best use of the features of PTG Series Pressure Transmitter.

For safe operation of this product, please follow the following safety instructions. Yamatake Corporation will not assume any liability for damages arising from failure to follow these safety instructions.

~Note *Good installation, correct operation, and post-installation maintenance are essential to safe use of your PTG Series Pressure Transmitter. The safety instructions are contained in this manual. Fully understand these instructions before installing, operating, and maintaining your PTG Smart Pressure Transmitter.*

Safety Standard

- The safety instructions presented in this Instruction Manual conform to ANSI (American National Standards Institute) Z535-4.
- In this manual, safety instructions are classified as either Warnings, Cautions, and Notes. The standard of classification is as follows:

WARNING

Failure to observe safety instructions in this category may result in personal injury or, even, death. Equivalent to definition "warning" in ANSI regulations.

CAUTION

Failure to observe safety instructions in this category could result in damage to or breakdown of equipment or facilities. Equivalent to definition "caution" in ANSI regulations.

~Note *Information that can be useful to the user. Equivalent to definition to "note" in ANSI regulations.*

Observe safe working practices

Note the following to ensure safety during installation and operation:

- Turn off the power switch before any wiring work.
- When opening the cover of the terminal box, pay due attention to the edges of the cover and the threads in the screws in the cabinet. If the PTG Smart Pressure Transmitter is an explosion model, NEVER open the terminal cover while the Transmitter is energized in operation.
- Do not stand on the installed Transmitter or use it as a step to prevent accidents.
- Do not touch the Transmitter unnecessarily while in operation. Surface may be very hot or very cold, depending on the process condition.

Unpacking and inspection

Unpacking

The PTG Series Smart Transmitter is a precision instrument. It has cleared various tests based on Yamatake's rigorous quality control programs. Handle it with care to prevent accidents or damage.

Open the package, and check that the following items are included:

- 1) Main PTG Smart Pressure Transmitter
- 2) Blind conduit plug (standard accessory)
- 3) Gasket (if process connection used a male screw)
- 4) 1 hexagonal wrench (standard accessory)
- 5) 2-inch pipe/wall mounting hardware set (optional)
- 6) Unit seal (for integral digital indicator type, optional)
- 7) Packing sets for wiring (For JIS explosion proof type): 1 packing, 2 washers

Checking the specifications

Specifications are printed to the nameplate of the PTG unit. Refer to the supplement, and make sure that the unit you have received matches to the model that you specified at the time of ordering. Then verify the followings:

Tag number (TAG NO.)

Type

Prom number (PROM No.)

Contact

If you find any doubt about the specifications, contact your Yamatake representative. When making an inquiry, provide unit's model number (MODEL) and product number (PROD.).

Storage

When storing your Transmitter unpacked, observe the following.

Store indoors, within specified storage temperature and humidity, in a location that is free from excessive shocks and vibrations. Store the unit original packing condition.

When storing your unit after use, follow these steps:

1. Firmly tighten the terminal box cover, and seal the conduit connection end with tape, to prevent the entry of moisture.
2. Seal the connection ends and bleed the hole in the pilot cover with tape, to prevent the entry of moisture and dirt.
3. Restore packing to original condition.
4. Store indoors, at ordinary temperature and humidity (about 25°C or 77°F, and 65% respectively), in a location that is free from excessive shocks and vibrations and not exposed to rain or water.

General precautions

- Do not use a transceiver within the area of 7 feet (2 meters) around the product, or around the connecting cables to the product. Doing so may result in malfunctioning of the product.
- Do not remove seals affixed to welds and the grounding cables until all pipes are installed.

Table of Contents

Chapter 1 : Descriptions of Parts

1-1 :Description of parts	1-1
---------------------------------	-----

Chapter 2 : Installation

2-1 :Installing screw-mount transmitters (model PTG__G)	2-1
Safety precautions.....	2-1
Installation precautions.....	2-1
Direct mounting onto the process line.....	2-4
Handling precautions.....	2-4
Installing the transmitter using the mounting brackets.....	2-5
2-2 :Installing flange-mount transmitters (model PTG__F)	2-7
Safety precautions.....	2-7
Installation precautions.....	2-7
Handling precautions.....	2-8
Installing flange-mount transmitters	2-9
Precautions.....	2-9
2-3 :Installing ferrule-mount (sanitary type) transmitters (model PTG__S).....	2-10
Safety precautions.....	2-10
Installation precaution.....	2-10
Handling precautions.....	2-11
Mounting of sanitary type transmitters	2-12
Mounting precautions	2-12
Example of mounting.....	2-12

Chapter 3 : Wiring

Wiring precautions.....	3-1
For JIS Explosion proof wiring.....	3-1
For FM and NEPSI Explosion-proof wiring.....	3-2
Wiring diagram	3-3
Power supply and external load resistance	3-4

Chapter 4 : Calibration

Zero adjustment.....	4-1
----------------------	-----

Chapter 5 : Maintenance and troubleshooting

Maintenance precautions	5-1
Maintenance.....	5-1
Troubleshooting.....	5-1

Table of Contents

Chapter 6 : Remote Communication

6-1 :Operation by SFC	6-1
Function of the SFC	6-1
Overview.....	6-1
Description of parts	6-1
Components	6-1
SFC keyboard.....	6-2
Connecting SFC to transmitter.....	6-3
Interactive communication.....	6-3
Displaying and changing settings	6-4
Parameters that can be displayed and changed	6-4
Starting communication	6-5
Procedure	6-5
Displaying and changing the tag number.....	6-6
procedure	6-6
Displaying the input pressure value	6-8
Procedure	6-8
Displaying the transmitted output (%).....	6-8
Procedure	6-8
Displaying or changing the upper and lower range values for range setting.....	6-9
Overview.....	6-9
Displaying the set range	6-9
Displaying or changing the engineering units	6-12
Procedure	6-12
Displaying or changing the damping time constant	6-13
Overview.....	6-13
Available damping time constants	6-13
Procedure	6-13
Displaying the direction of output overshooting when an abnormal condition occurs.....	6-15
Abnormal conditions	6-15
Procedure	6-15
Displaying the manufacturing number (PROM NO.).....	6-16
Overview.....	6-16
Procedure	6-16
Displaying the temperature of sensor	6-17
Procedure	6-17
Displaying the software version	6-18
Procedure	6-18
Printing function (Optional)	6-19
Printing	6-19
Feeding the form	6-19
Printing function: Printing out data stored in the transmitter	6-20
To print out data stored in the transmitter.....	6-20
Procedure	6-20
Example of maintenance printing	6-21

Table of Contents

Printing function: Continuous printing (Action print).....	6-22
Action print.....	6-22
Example of action printing	6-23
Output mode	6-24
Overview.....	6-24
Procedure	6-24
Canceling the output mode	6-25
Procedure	6-25
Checking the display format (Linear output) of the Indicator (Optional).....	6-26
Procedure	6-26
Checking and changing the display format of the indicator	6-27
Procedure	6-27
Checking or changing the upper and lower range values on the indicator	6-28
Overview.....	6-28
Procedure	6-28
6-2 :Calibration by SFC.....	6-30
Verify the output signal	6-30
Procedure	6-30
Saving the calibrated values and cancelling the Output Mode	6-32
Procedure	6-32
Calibrating the set range by inputting the actual pressure.....	6-33
Overview.....	6-33
Calibration devices	6-33
Requirements for calibration.....	6-33
Assembling the calibration devices	6-34
Calibrating the lower range value	6-35
Procedure	6-35
Calibrating the upper range value.....	6-37
Procedure	6-37
Resetting calibrated data	6-39
Procedure	6-39
Erasing the # symbol	6-40
Overview.....	6-40
Setting LRV for actual pressure.....	6-40
6-3 :Self-diagnostic messages from SFC.....	6-43
Troubleshooting and verification of normal functioning.....	6-43
Verifying the normal functioning and self-diagnosis	6-43
Procedure	6-43
If abnormal conditions are encountered during communication	6-44
Message and action	6-44
Self-diagnostic message	6-45
Message	6-45
Insulation resistance test, voltage withstand test.....	6-48
Precautions.....	6-48
Test procedure	6-48

Table of Contents

Chapter 7 : Spare Parts..... 7-1

Appendix - Operational Manual for HART® Communication (For Model PTG72)

Section 1 :Starting Communications	A-1
Connecting Communicator	A-1
HART® Communicator Keyboard.....	A-2
Symbols on Communicator Screen	A-3
Keying in Alphanumeric Characters.....	A-3
Establishing Communications.....	A-4
Checking Basic Data.....	A-5
Section 2 :Configuration.....	A-6
HART® Communicator Menu Summary	A-7
Changing Tag No.....	A-8
Indicator Display Format	A-8
Display Type.....	A-8
EULO / EUHI	A-8
Over Range	A-8
Selecting unit of Measurement	A-9
Setting Range Values	A-9
Adjusting Damping Time.....	A-10
Section 3 :Start-up and Operation.....	A-11
Running Analog Output Check	A-11
Configuring Ranges with Applying Pressure.....	A-12
Section 4 : Calibration	A-13
Calibrating Analog Output Signal.....	A-13
Calibrating Range	A-14
Resetting Calibration.....	A-14
Section 5 :Service Setup Menu	A-15
Entering Service Setup Menu	A-15
DE Mode	A-15
Failsafe Direction	A-16

List of Figure

Figure 1-1	General view (front view)	1-1
Figure 1-2	General view (rear view).....	1-1
Figure 1-3	Flange mount type model PTG__F	1-2
Figure 1-4	Ferrule mount for sanitary type, model PTG__S.....	1-2
Figure 1-5	Mounting bracket (optional) for screw mount type	1-3
Figure 2-1	Installation precaution 1	2-2
Figure 2-2	Installation precaution 2	2-3
Figure 2-3	An example of the direct-mount method	2-4
Figure 2-4	Installing the transmitter with the mounting brackets on a panel and 2-inch pipe ...	2-5
Figure 2-5	Dimensions of mounting bracket	2-6
Figure 2-6	Parts schematic of flange-mount type transmitter.....	2-9
Figure 2-7	Example of mounting sanitary type transmitter	2-12
Figure 3-1	Wiring diagram	3-3
Figure 3-2	Relationship between power supply voltage and external load resistance	3-4
Figure 4-1	Zero adjustment.....	4-1
Figure 6-1	Components of SFC	6-1
Figure 6-2	SFC keyboard.....	6-2
Figure 6-3	Connecting the SFC	6-3
Figure 6-4	Example of maintenance printing	6-21
Figure 6-5	Example of action printing.....	6-23
Figure 6-6	Wiring and piping for the calibration devices.....	6-34
Figure 7-1	Exploded view.....	7-1
Figure A-1	HART® Communicator keyboard.....	A-1
Figure A-2	HART® Communicator.....	A-2
Figure A-3	HART® Communicator keyboard.....	A-2

Chapter 1 : Descriptions of Parts

1-1 : Description of parts

Figure 1-1 and Figure 1-2 show expanded front and rear views of the PTG Pressure Transmitter.

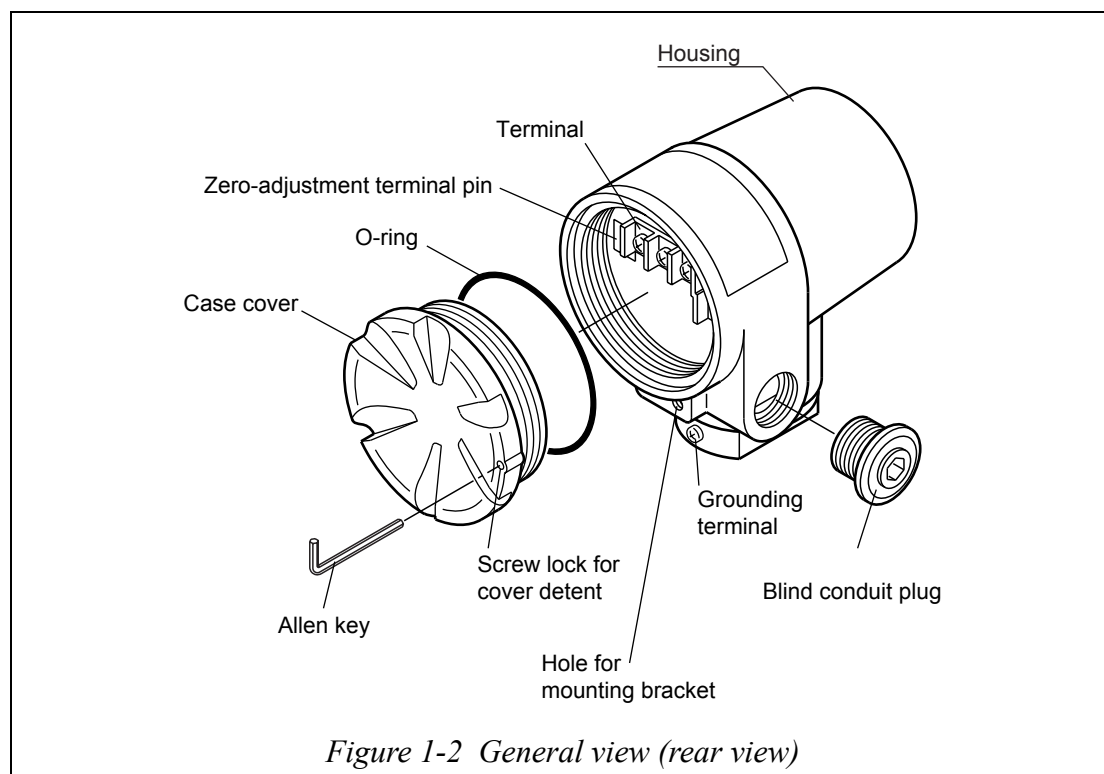
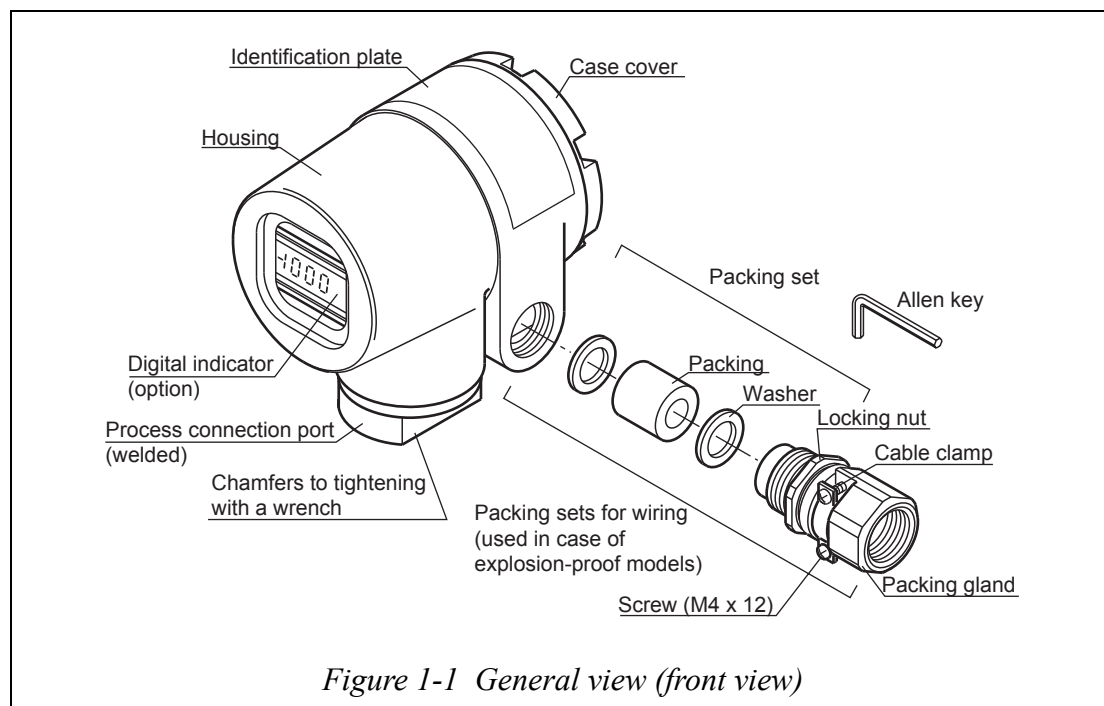

The various types of mounting are given in Figure 1-3 and 1-4.

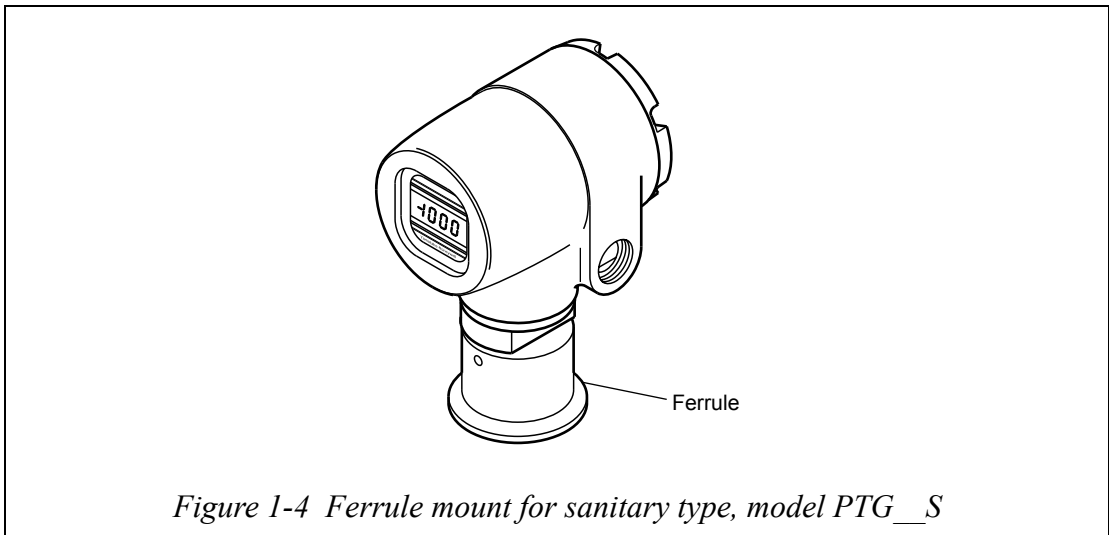
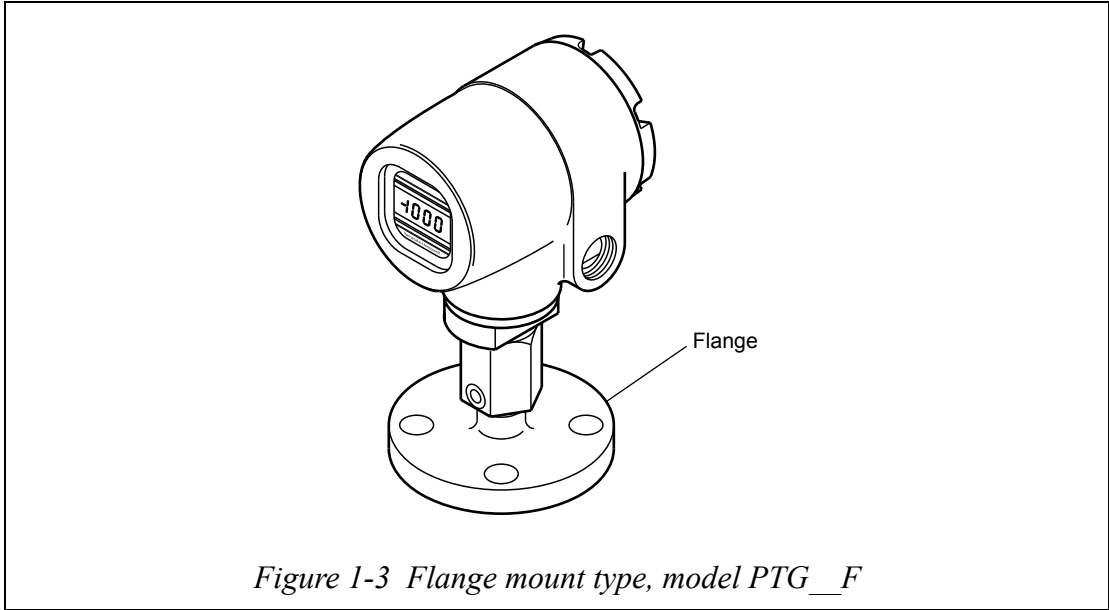

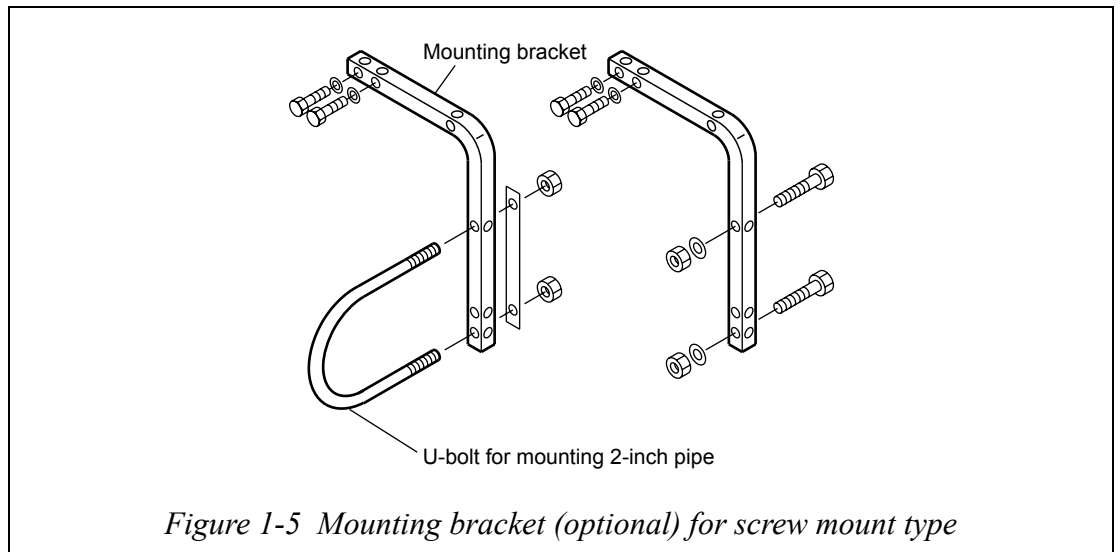

Chapter 2 : Installation

2-1 : Installing screw-mount transmitters (model PTG__G)

Safety precautions



CAUTION

- After the PTG Transmitter is installed, do not use it as a foothold or any other improper purpose. Doing so may result in damage to equipment and/or physical injury.
- Hitting the glass portion of the indicator with a tool may break the glass and/or cause physical injury. Caution must be exercised if your PTG Transmitter is equipped with an optional digital indicator.
- Be careful when installing the transmitter if the process fluid temperature is high. The heat of the fluid and/or the heat radiated from the piping may raise the surface temperature of the Transmitter very high.

Installation precautions

- When installing the Transmitter, position and secure the gasket so that it does not protrude from where the Transmitter is connected to the process (where an adapter flange is coupled to a connecting pipe). If the gasket sticks out, liquid leakage or output error may result.
- Do not use the Transmitter under any other operating conditions than specified in the product specifications (i.e., rated pressure, connection standard, rated temperature, rated vibration and rated humidity). Using this product under incorrect operating conditions may cause damage to the product and leakage that could lead to a major accident.
- Wiring work in hazardous area should be performed carefully by following the work methods specified in the explosion-protection guidelines.
- Connect the Transmitter to a good ground. If it is not grounded or the ground is inadequate, output error will occur. Not grounding the transmitter is a violation of regulations. Be careful of your footing during installation. Always wear safety shoes.
- This product can be installed directly on the pipe (direct mounting), on a 2-inch pipe with the mounting brackets (optional part), or on a wall.
- Connecting pipe arrangement
- Piping conditions differ depending on the process.
 - Liquid: Establish a tap alongside the line and install the Transmitter next to or beneath the tap to allow gas to return to the inside of the process line.
 - Gas: Establish a tap on top of or alongside the line and install the Transmitter next to or above the tap to allow liquid to return to the inside of the process line.

Steam: Establish a tap alongside the process line and install the Transmitter beneath that tap to allow condensation to return through the connecting pipe.

Handling precautions

- Securely wrap a sealing tape around the joint of the connecting pipe to prevent process leakage.
- Using wrenches, securely tighten the wetted part and connecting pipe of the Transmitter. In so doing, use the wrenches to hold the parallel chambers at the wetted part. Do not tighten it by holding the housing of the product as this may cause damage to the Transmitter. Avoid holding the housing when tightening without a wrench. (See Figure 2-1.)
- Avoid installing the Transmitter with its front side facing down. Doing so invites water, dirt and other sediment to deposit at the wetted part, causing an inaccurate measurement.
- If the process temperature exceeds 110°C (230°F), take some measures, such as installing a siphon, to defuse the high temperature at the wetted part so it does not exceed 110°C (230°F).
- Install the Transmitter in a location where the liquid process does not freeze. Otherwise, take some measures to keep the process fluid from freezing.
- Install the Transmitter in a location where there is no excessive impact, vibration or pressure (such as water hammering).
- During filling the connecting pipe with process liquid, 10 MPa {1,450 PSI} or an equivalent pressure may be applied. Do not screw the Transmitter into a connecting pipe during filling, as it may lead to critical damage to the Transmitter. (See Figure 2-2.)

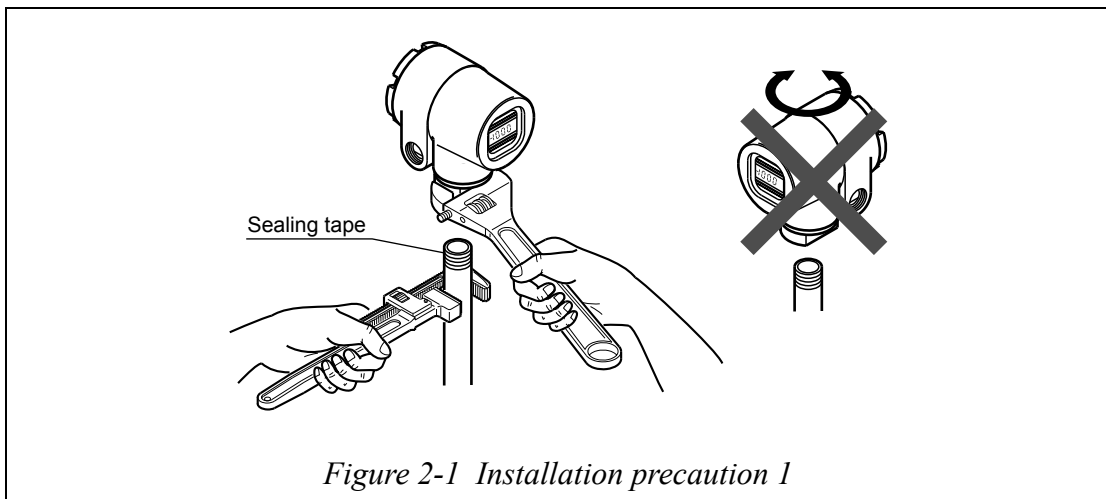

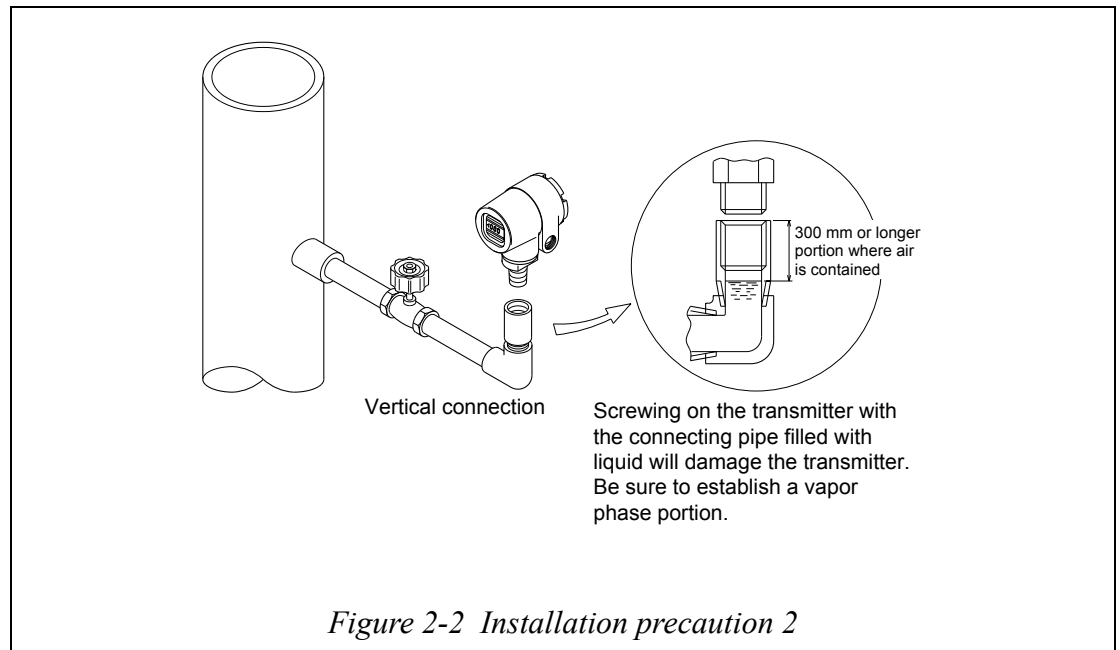

Direct mounting onto the process line

Handling precautions

- When mounting the Transmitter directly onto the process line, full consideration must be given as to its weight, the temperature at the wetted part and to vibration.
- The method of connecting the Transmitter to the process line must be appropriate for each given process.
- Figure 2-3 shows an example of the direct-mount method.

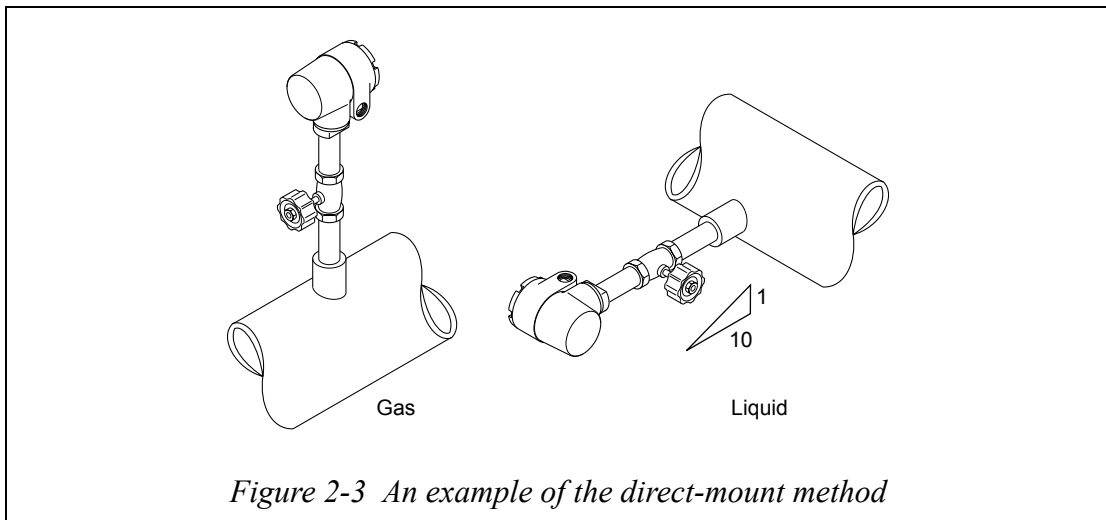

Installing the transmitter using the mounting brackets

Mounting Brackets are supplied with the Transmitter. For additional mounting hardware, refer to “Chapter 7 : Spare Parts”. With the mounting bracket, the Transmitter can be installed on a 2-inch pipe or on a panel.

Fig. 2-4 illustrates examples of installing the Transmitter with the mounting brackets. Fig. 2-5 gives the dimensions of the mounting brackets.

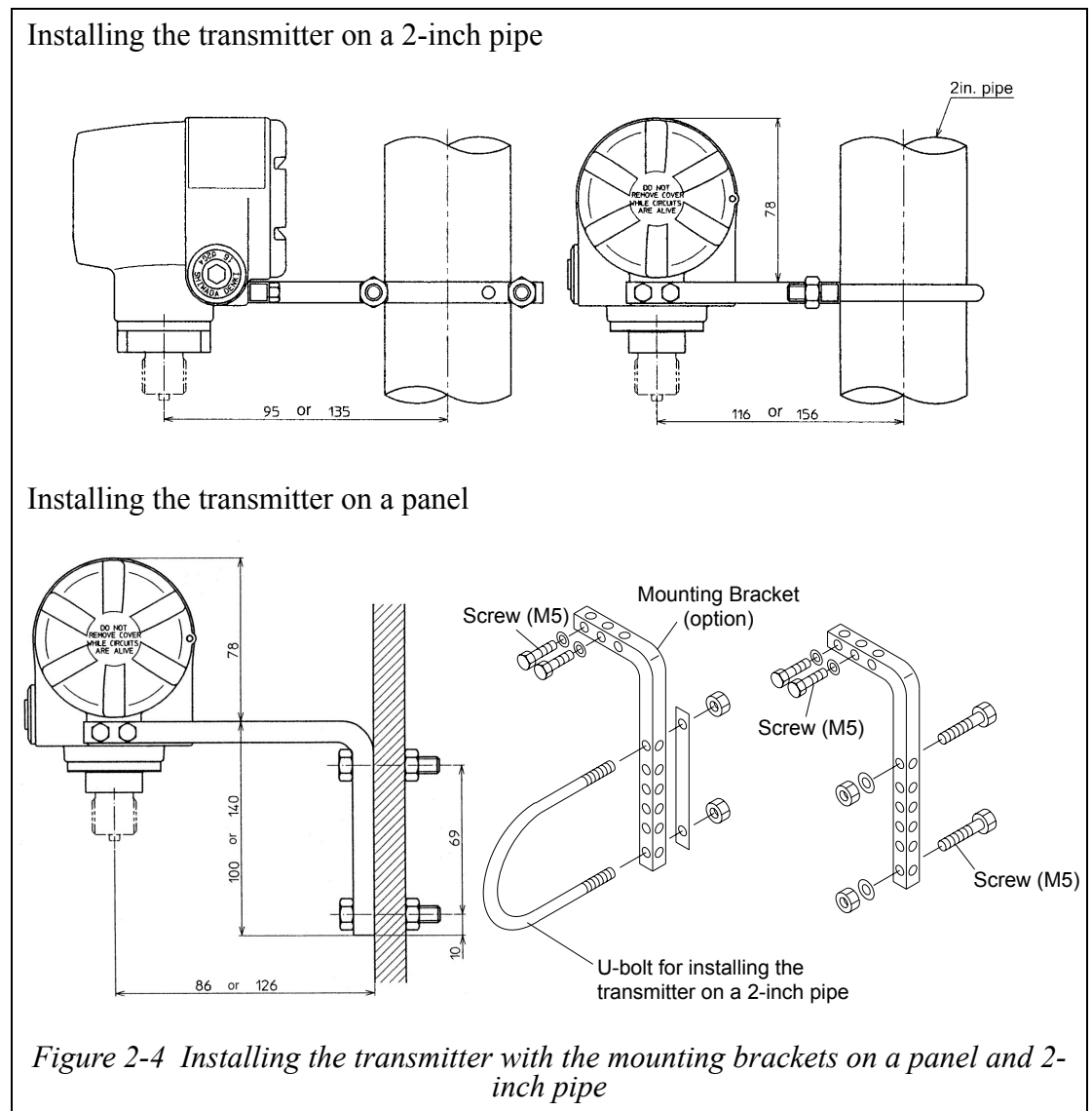

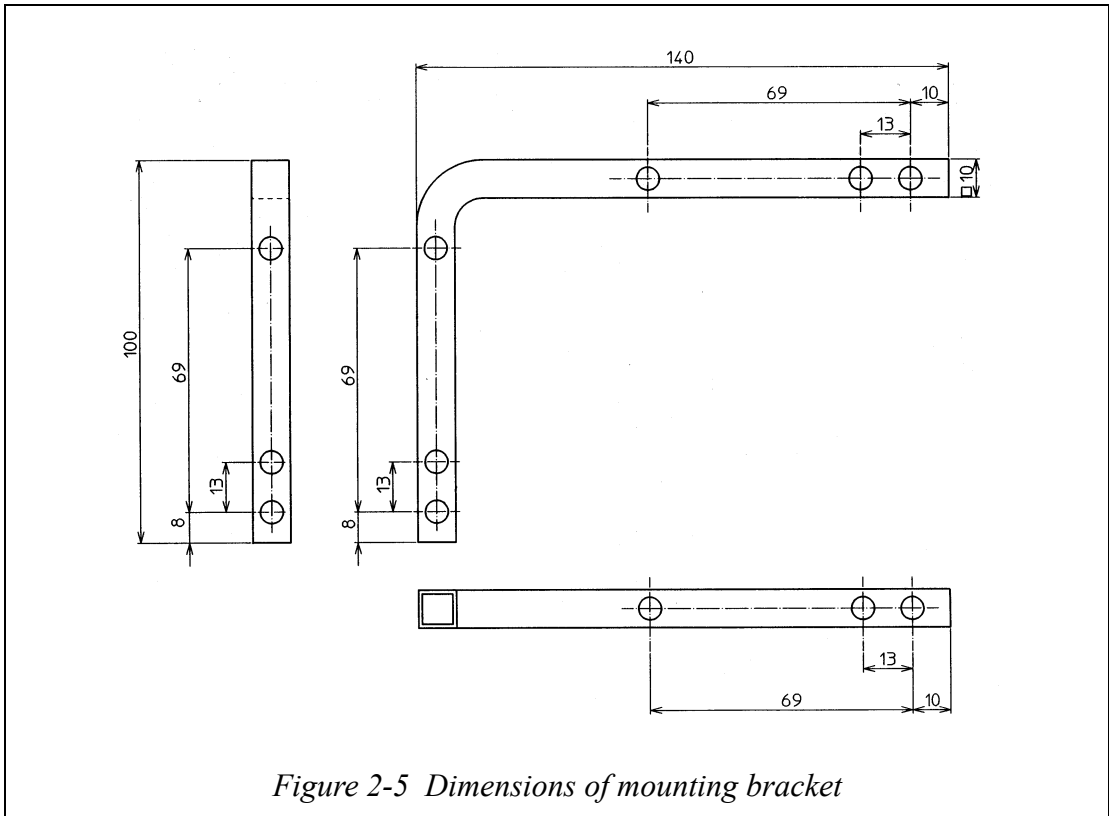

Figure 2-5 Dimensions of mounting bracket

2-2 : Installing flange-mount transmitters (model PTG__F)

Safety precautions



CAUTION

- After the Transmitter is installed, do not use it as a foothold or any other improper purpose. Doing so may damage the equipment and/or result in physical injury.
- Hitting the glass portion of the indicator with a tool may break the glass and result in physical injury. Caution must be exercised for products equipped with an digital indicator.
- Be careful when installing the Transmitter if the process fluid temperature is high. The heat of the fluid and/or the heat radiated from the piping may raise the surface temperature of the Transmitter very high.
- Fasten the flange with the specified torque to prevent the leakage from the flange connection.

Installation precautions

- When installing the Transmitter, position and secure the gasket so that it does not protrude from where the Transmitter is connected to the process (where an adapter flange is coupled to a connecting pipe). If the gasket sticks out, liquid leakage or output error may result.
- Do not use the Transmitter under any other operating conditions than specified in the product specifications (i.e., rated pressure, connection standard, rated temperature, rated vibration and rated humidity). Using this product under incorrect operating conditions may cause damage to the product and leakage that could lead to a major accident.
- Wiring work in hazardous area should be performed carefully by following the work methods specified in the explosion-protection guidelines.
- Properly ground the Transmitter. If it is not grounded or the ground is inadequate, output error will occur. Not grounding the transmitter is a violation of regulations. Be careful of your footing during installation. Always wear safety shoes.
- This product can be installed directly on the pipe (direct mounting), on a 2-inch pipe with the mounting brackets (optional part), or on a wall.

Handling precautions

- Mounting procedure: Piping conditions differ depending on the process.
Liquid: Mount the nozzle on the pipe side and install the Transmitter sideways away from the nozzle or below the nozzle so that no deposit is produced and the gas generated returns to the process piping.
Gas: Mount the nozzle on top or to the side of the process pipe and install the Transmitter beside or above the nozzle so that the process returns to the process piping.
Steam: Mount the nozzle in the pipe side and install the Transmitter at the down-side of the nozzle so that the condensed water collects in the conduit piping.
- Weld or bind with a sealing tape securely to the piping joint to prevent a process leakage from occurring.
- Avoid installing the Transmitter with its front side facing down. Doing so invites water, dirt and other sediment to deposit at the wetted part, causing an inaccurate measurement.
- If the process temperature exceeds 110°C (230°F), take some measures, such as installing a siphon, to defuse the high temperature at the wetted part so it does not exceed 110°C (230°F).
- Install the Transmitter in a location where liquid process does not freeze. Otherwise, take some measures to keep the process fluid from freezing.
- Install the Transmitter in a location where there is no excessive impact, vibration or pressure (such as water hammering).

Installing flange-mount transmitters

Precautions

- Mount the Transmitter considering its weight, the temperature at its wetted part and possible vibration.
- Connect the conduit to satisfy the given process requirements.

Figure 2-6 below shows an example of flange-mount type Transmitter.

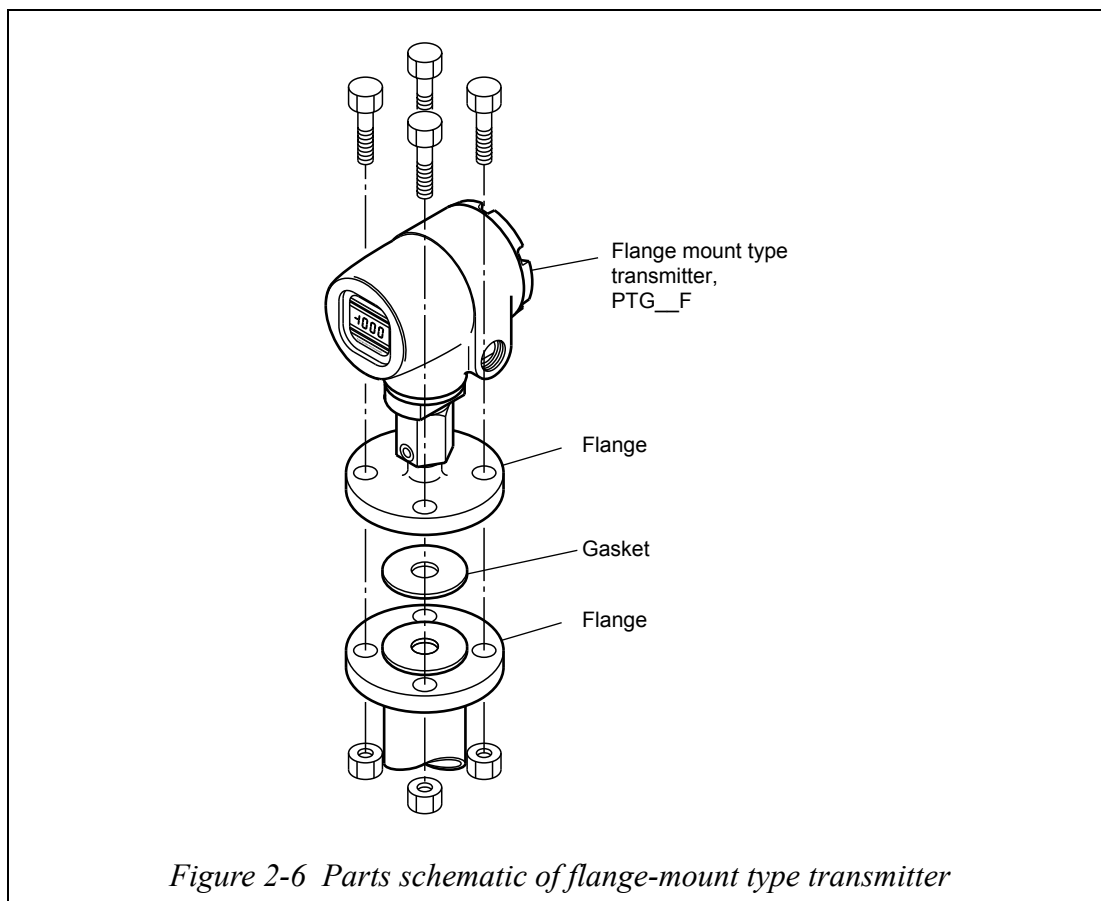

2-3 : Installing ferrule-mount (sanitary type) transmitters (model PTG__S)

Safety precautions

CAUTION

- After the Transmitter is installed, do not use it as a foothold or any other improper purpose. Doing so may damage the equipment and/or result in physical injury.
- Hitting the glass portion of the indicator with a tool may break the glass and result in physical injury. Caution must be exercised for products equipped with a digital indicator.
- Be careful when installing the Transmitter if the process fluid temperature is high. The heat of the fluid and/or the heat radiated from the piping may raise the surface temperature of the Transmitter very high.

Installation precaution

- When installing the Transmitter, position and secure the gasket so that it does not protrude from where the Transmitter is connected to the process (where an adapter flange is coupled to a connecting pipe). If the gasket sticks out, liquid leakage or output error may result.
- Do not use the Transmitter under any other operating conditions than specified in the product specifications (i.e., rated pressure, connection standard, rated temperature, rated vibration and rated humidity). Using this product under incorrect operating conditions may cause damage to the product and leakage that could lead to a major accident.
- Wiring work in hazardous area should be performed carefully by following the work methods specified in the explosion-protection guidelines.
- Properly ground the Transmitter. If it is not grounded or the ground is inadequate, output error will occur. Not grounding the transmitter is a violation of regulations. Be careful of your footing during installation. Always wear safety shoes.
- Mounting procedure: Piping conditions differ depending on the process.

Liquid: Mount the nozzle in the pipe side and install the Transmitter sideways to or to the downside of the nozzle so that no deposit is produced and the gas generated returns to the process piping.

Gas: Mount the nozzle to the top or the side of the process pipe and install the Transmitter side by side with or to the upper side of the nozzle so that the process returns to the process piping.

Steam: Mount the nozzle on the pipe side and install the Transmitter at the downside of the nozzle so that the condensed water collects in the conduit piping.

Handling precautions

- Weld or bind with a sealing tape securely to the piping joint to prevent a process leakage from occurring.
- Avoid installing the Transmitter with its front side facing down. Doing so invites water, dirt and other sediment to deposit at the wetted part, causing an inaccurate measurement.
- If the process temperature exceeds 110°C (230°F), take some measures, such as installing a siphon, to defuse the high temperature at the wetted part so it does not exceed 110°C (230°F).
- Install the Transmitter in a location where liquid process does not freeze. Otherwise, take some measures to keep the process fluid from freezing.
- Install the Transmitter in a location where there is no excessive impact, vibration or pressure (such as water hammering).

Mounting of sanitary type transmitters

Mounting precautions

Mount the transmitter taking into consideration its weight as well as the temperature at its wet part and any possible vibration.

Example of mounting

Figure 2-7 below shows an example of mounting a sanitary type transmitter.

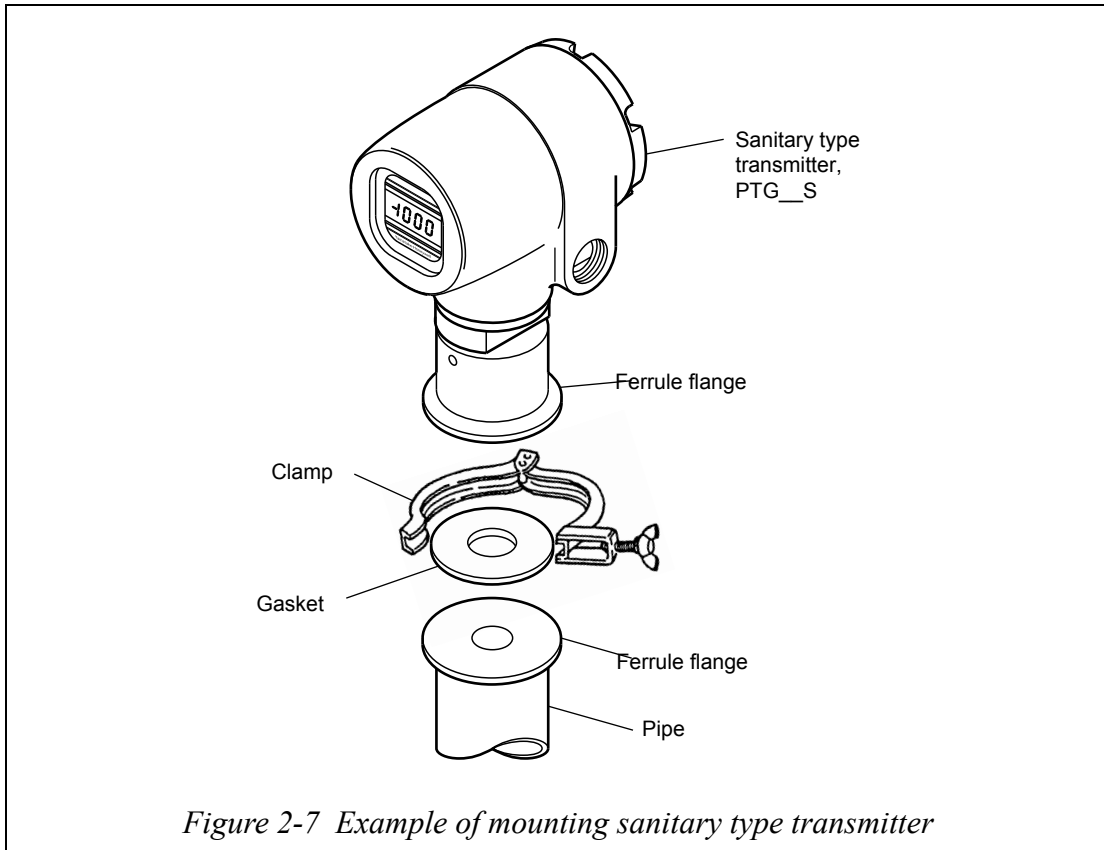

Chapter 3 : Wiring

Wiring precautions

CAUTION

Performing wiring work with wet hands or with power applied may result in electrical shock. Perform wiring work with dry hands, always wear gloves and disconnect the power to the Transmitter before performing wiring work.

- Check the specifications before wiring. Incorrect wiring will cause damage to or malfunction of the product.
- Use a power supply which adheres to the specifications. Incorrect power supply will cause a damage to the product.
- The product is designed based on a two-wire wiring system. The power supply line also functions as a signal line. The wires are routed through the conduit hole on the side face of the Transmitter and are connected to the terminals. The conduit end is potted with sealing agent or capped with a sealing plug so the water cannot penetrate into the oscillator housing. The connecting wires to the terminals must be drawn in below the position where the connection port is located.
- Grounding wire

The transmitter has two grounding terminals: one at the terminal and the other on the outside face. Either terminal can be used. The grounding terminal must be connected to a class 3 ground (grounding resistance 100 Ω or less) or better.

For JIS Explosion proof wiring

A model PTG71_ conforming to the Japan Industrial Standard (JIS) explosion-proof regulations is optionally available, and has a certified explosion-proof structure (Exds II CT4).

WARNING

-
- Be sure to perform wiring work with the power turned off. If the power is turned on, this may result in electrical shock.
 - Turning on the power in an explosion-protected area while the housing is open may result in explosion.
-
- Be sure to use the grounding cable and the set of pressure packings shipped with the transmitter. Using a cable or packing other than the ones shipped with the product will void the explosion-proof qualification of the transmitter.
 - After the wires are connected, be sure to close the cover and tighten the screw lock that holds the cover detent in place. One requirement for an explosion-proof structure is that the cover must be locked.

- Installation and connection are to conform to the guidelines for industrial safety research and technology “Guide to Industrial Explosion-proof Electrical Equipment for Users” (published by Industrial Safety Institute of the Ministry of Labor, Japan) or equivalent.

For FM and NEPSI Explosion-proof wiring

A model PTG71_ Transmitters are conforming to Factory Mutual (FM) or NEPSI / GB explosion-proof regulations and are optionally available.



WARNING

-
- Be sure to turn off the power switch before performing the wiring work to avoid electrical shock to a personnel.
 - Turning on the power in an explosion-protected area while the housing is open can induce an explosion.
-
- Be sure to use the grounding cable and the pressure packings.
 - After the wiring is done, be sure to close the housing and tighten the screw lock securely. One important requirement for an explosion-proof structure is that the housing must be locked.

Wiring diagram

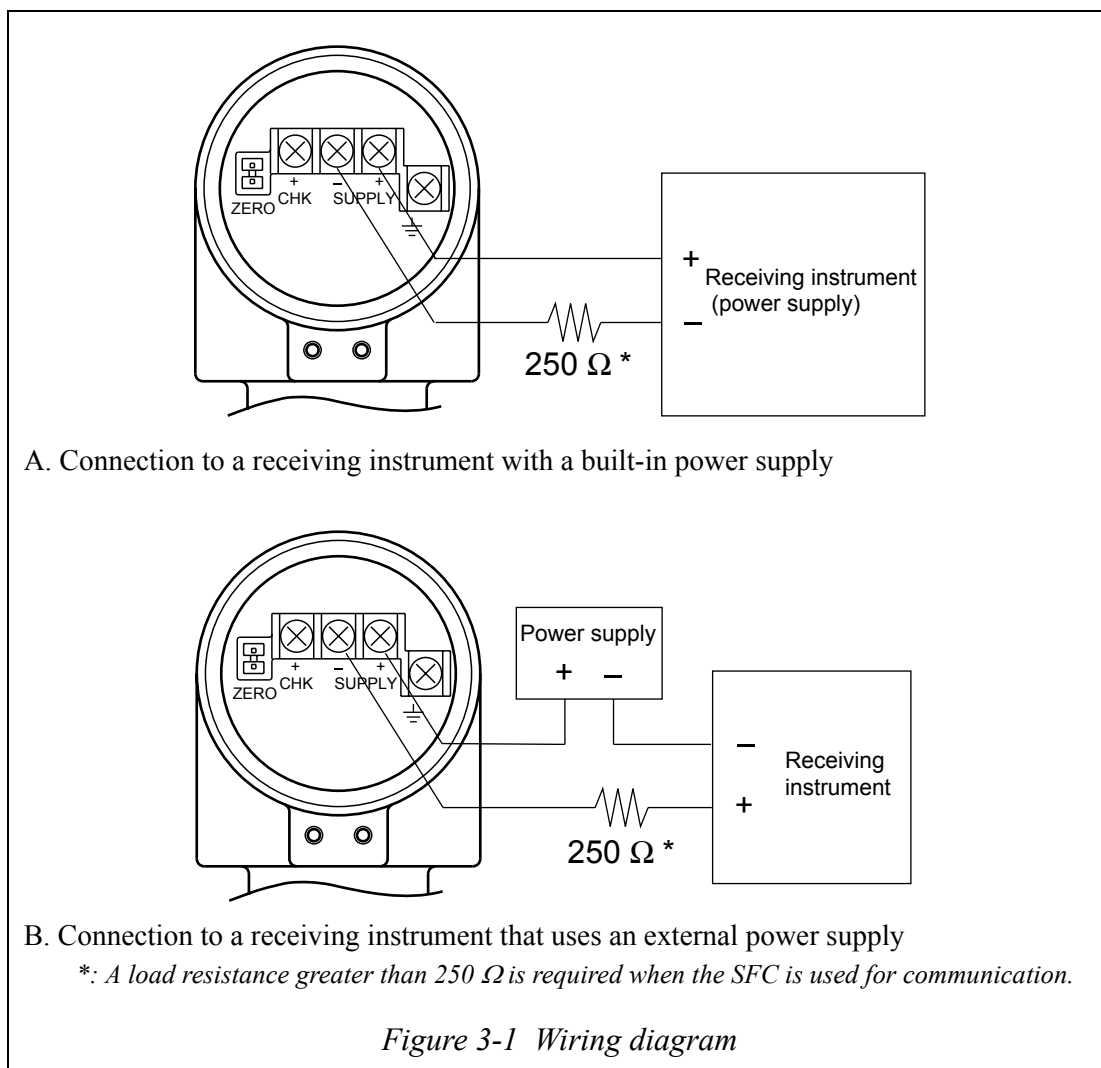

Power supply and external load resistance

External load resistance should be determined in relation to the voltage of the power supply so that both fall inside the diagonally-shaded area below.

External load resistance is the total resistance connected to the output terminals of the Transmitter, which includes the resistance in the cables forming the loop, the internal resistance in instruments connected between the Transmitter and the power supply, etc.

The abscissa axis shown in the figure is the voltage of the Transmitter’s power supply and the ordinate axis is the external load resistance.

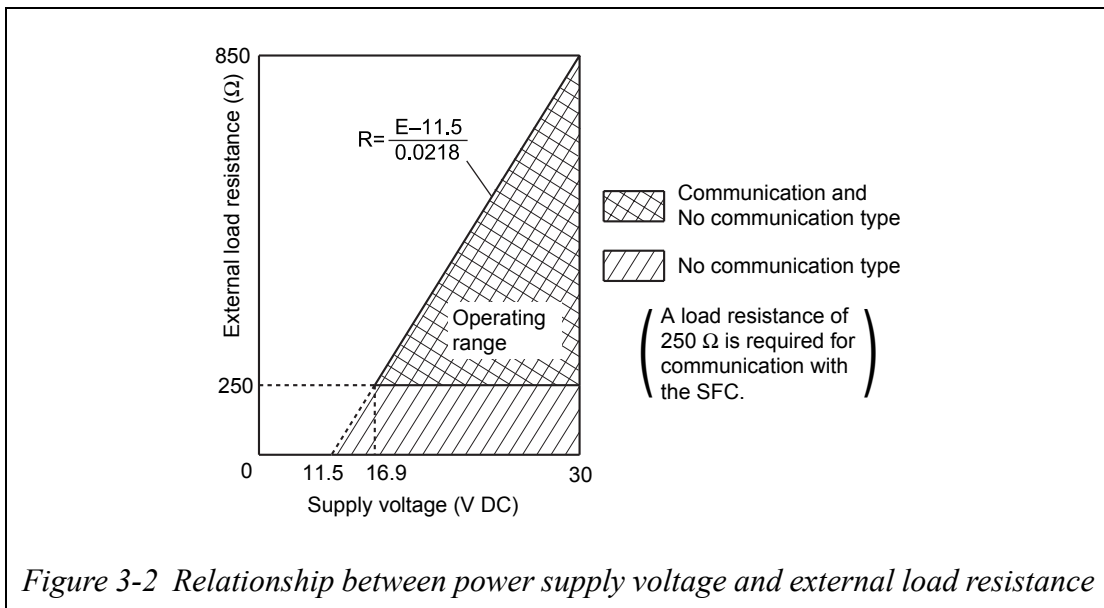

Chapter 4 : Calibration

With the PTG Series Transmitter, no span interference will occur once its zero-point calibration is complete. That is, only one zero-point adjustment is needed for a complete calibration.

Zero adjustment

Caution: Zero adjustment must be performed in a non-hazardous area.

Calibration procedure

1. Connect the power supply to the Transmitter.
2. Apply the pressure corresponding to 0% output. In order to set this 0% output to 0 kPaG, release any gas or liquid from the wetted part and leave it open to atmospheric pressure.
3. This product has two zero adjustment terminal pins.

Using a flat-head screwdriver, allow the two terminal pins to contact each other simultaneously (for about one second). (For products equipped with a built-in digital indicator, when two terminal pins contact each other the word “ZERO” will appear on the indicator.)

4. The Step 3 above completes zero adjustment.

Test terminal

When checking the output from the Transmitter for maintenance purpose, connect an amperemeter to the “CHK +” terminal and to “-” of the Transmitter’s “SUPPLY” terminal.

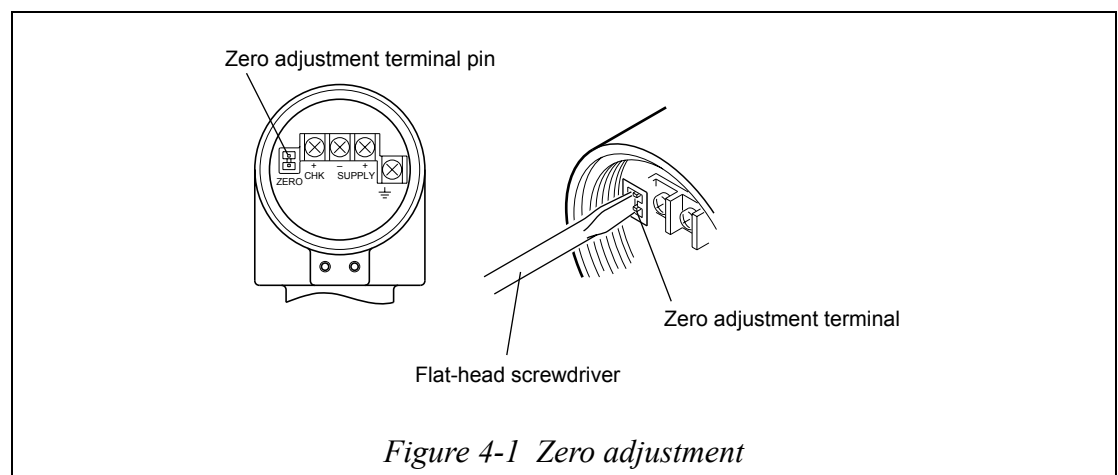

Chapter 5 : Maintenance and troubleshooting

Maintenance precautions

WARNING

-
- If the Transmitter must be disconnected from the process for the maintenance purposes, careful attention must be paid to the possible residual process and pressure. Personal injury may result from the generation of gas or release of liquid process.
 - When draining the process from the Transmitter through a vent hole, check the direction of the gas or liquid being drained. This precaution is to protect you from possible scalding or inhaling harmful fume due to exposure to the process being drained.
 - Do not open the housing cover while in operation in explosion-proof area. Opening the cover may induce an explosion.
-
- This product is manufactured and shipped under Yamatake Corporation's rigorous quality control system. Do not modify the product. Doing so will cause critical damage to the product.

Maintenance

Check the following on periodic basis:

- Has the housing, cover or grounding cable been damaged?
- Are the grounding cable, cover or housing-detent screws loose?
- Are the terminal screws loose?
- Is there any deterioration of the O-rings fitted to the set-screws holding the housing in position?
- Is there any leakage from the connection pipes?

Troubleshooting

If the product does not function properly, release the process gas or liquid from the product, leave it open to the atmosphere, and check the following items:

- Are there any loose or broken wires?
- Are the readings correct for power source voltage and load resistance?
- Is there any sediments or foreign objects at the wetted part?
- Is there dirt or debris present, clogging the connecting pipe? Is the gate valve fully open?

Chapter 6 : Remote Communication

6-1 : Operation by SFC

Function of the SFC

Overview

By using the SFC (Smart Field Communicator), optionally available, enables you to communicate remotely with the Transmitter. Starting measurement, reading measured data, setting (changing) measurement conditions, and canceling measurement can all be performed with the SFC. All communications with the Transmitter are displayed in the data display window and can be printed out as needed.

Description of parts

Components

Figure 6-1 "Components of SFC" shows the components of SFC and its accessories. The SFC model shown below has an integral printer (optional).

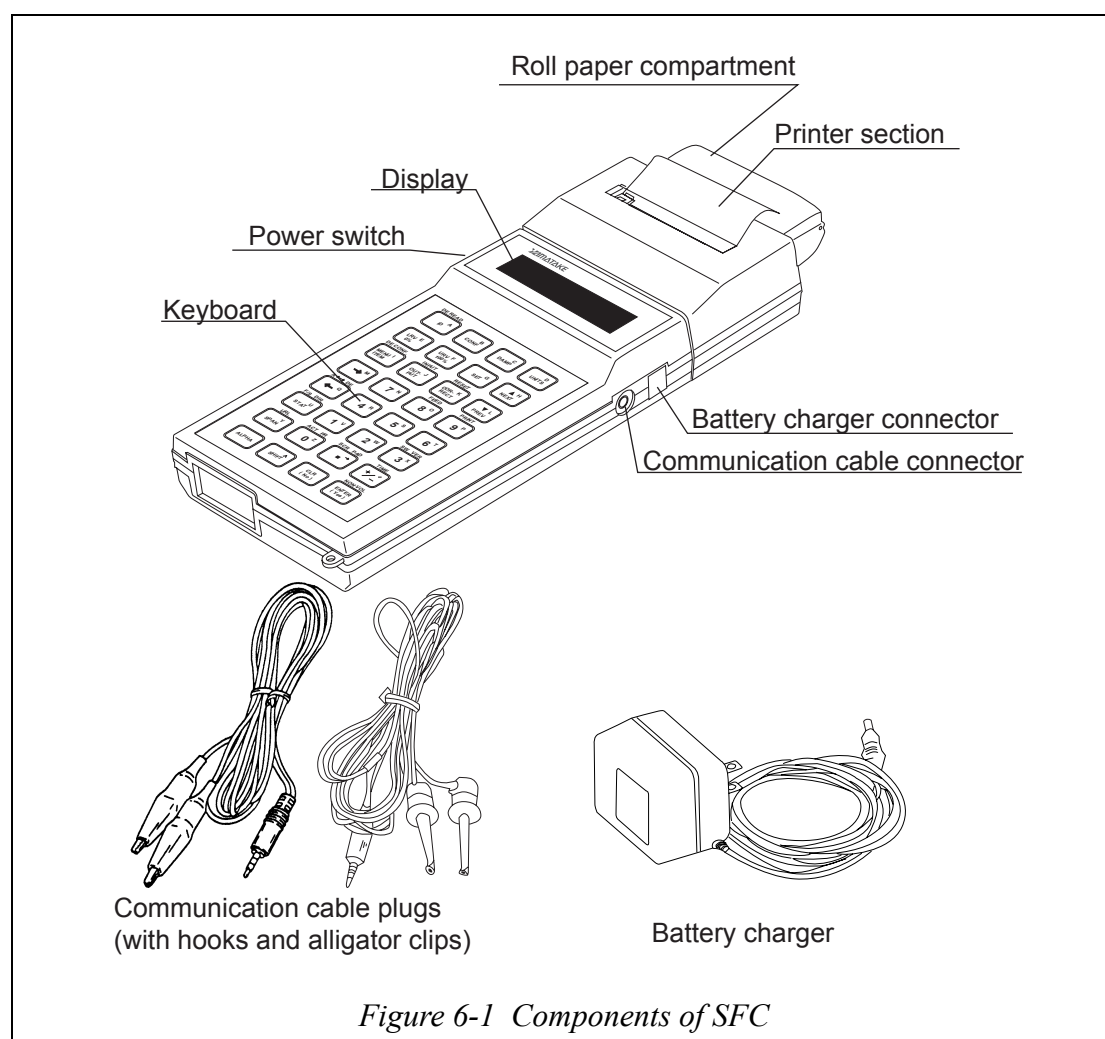

SFC keyboard

SFC keyboard shows the keyboard of the SFC.

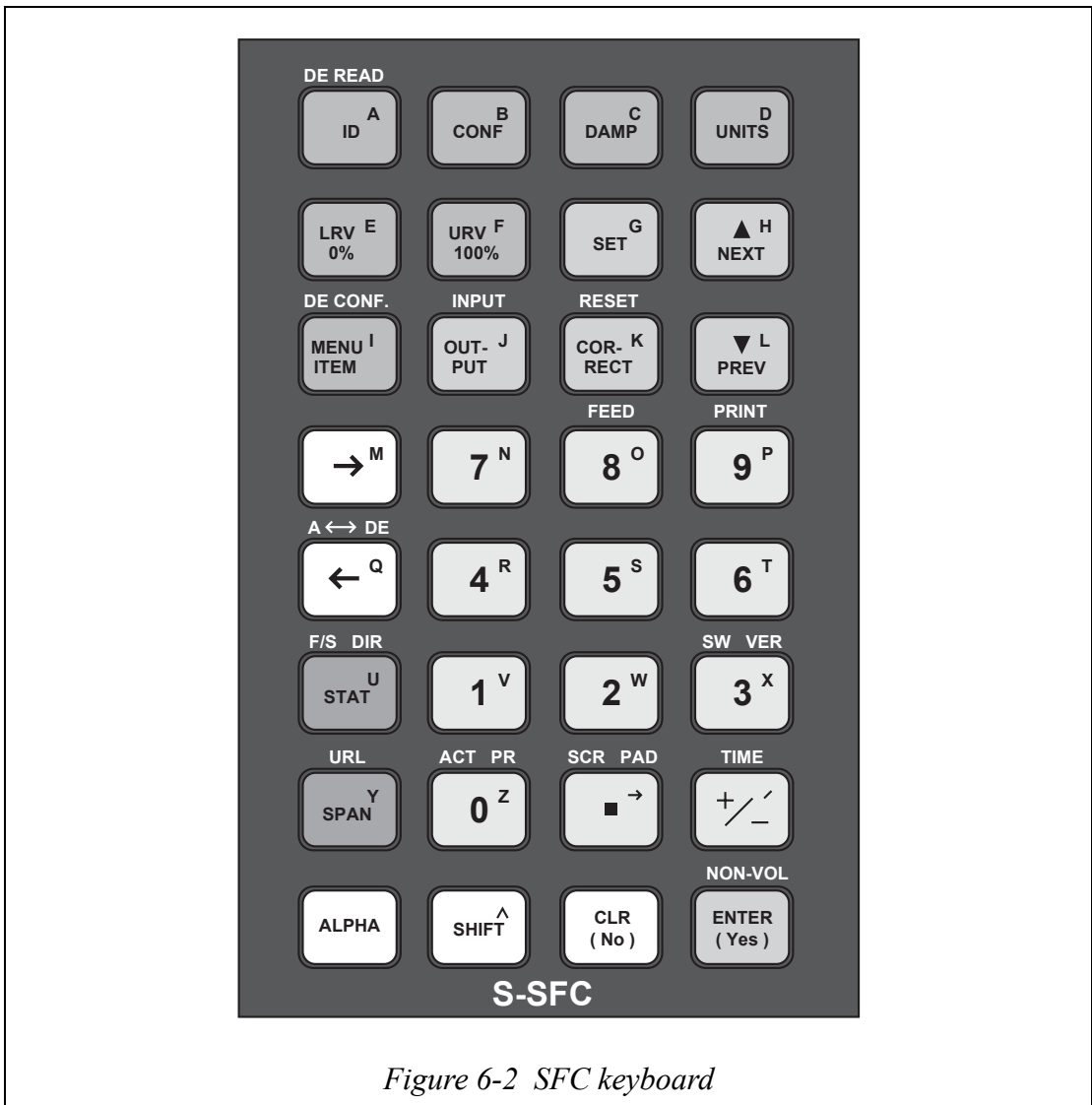

Figure 6-2 SFC keyboard

Connecting SFC to transmitter

Figure 6-3 shows how SFC is connected to the Transmitter.

Connect the communication cable of SFC to the correct transmitter terminal as shown in Figure 6-3.





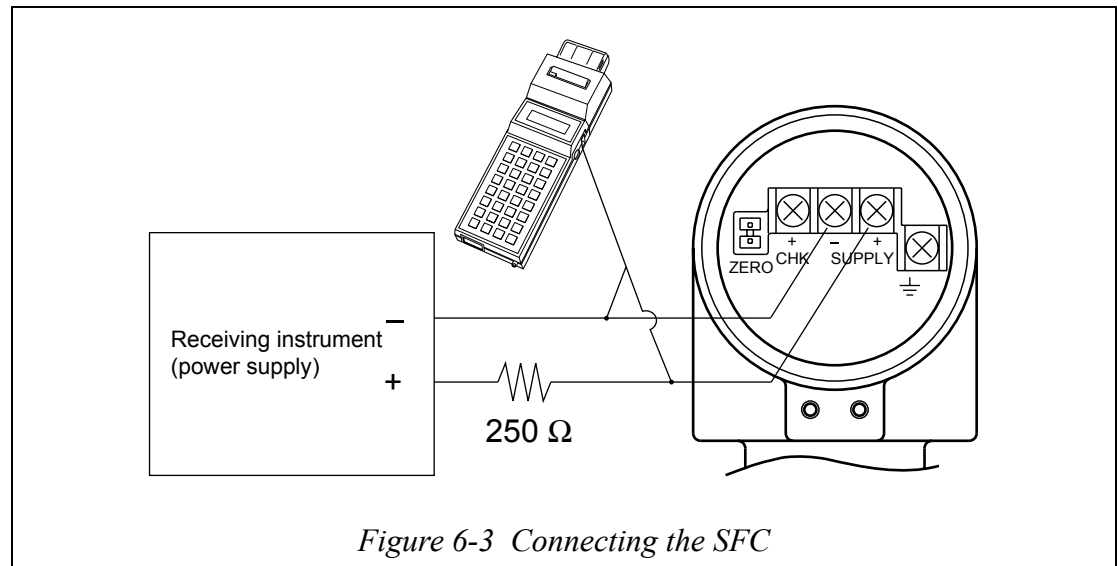

Red wire: Supply + terminal

Black wire: Supply – terminal



Interactive communication

The SFC enables an interactive communication with the Transmitter by operating the keyboard. The followings are some basic rules of operation.

- If you want to respond “Yes,” to a question on the screen, press the  key.
- Pressing the  key in the special-function screen will advance you to the next menu level.
- If you want to respond “No”, press the  key. Pressing the  key in the special-function screen will return you to the previous menu level. Pressing and holding down the  key will return you to the initial screen.
 - When selecting an another function in the same menu level, press either the  key or the  key.

 **CAUTION**

If a “:” mark shown below appears in the eighth digit at the top of the SFC screen, immediately discontinue the operation of SFC and recharge the battery. If you ignore this warning and continue operating, the SFC battery will be irreversibly damaged.

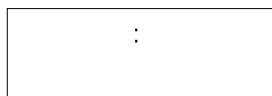

Displaying and changing settings

Parameters that can be displayed and changed

From the SFC, you can display and change the parameters as shown below.

Note: These parameters can be displayed and changed during measurement.

✓ : can be displayed or changed
 -: cannot be displayed or changed

Parameter	Display	Change
Tag number	✓	✓
Lower-limit value of range setting	✓	✓
Upper-limit value of range setting	✓	✓
Span of range setting	✓	*
Units of measurement	✓	✓
Damping-time constant	✓	✓
Direction of output overshoot during abnormality	✓	-
PROM number	✓	-
Software version	✓	-
Temperature at the sensor	✓	-

* Although this parameter cannot be changed directly, LRV or URV operation causes this parameter to change accordingly.



Starting communication

WARNING

- Before starting communication with the Transmitter via the SFC, switch the process control loop over to manual control mode.
- Starting communication with the Transmitter while the process control loop is still in the auto control mode, abrupt changes in output may occur, leading into a dangerous operational condition.

Procedure















To start communication with the Transmitter, follow the procedures below.





Step	Description	SFC screen
1	Check to make sure that the process is in the manual control mode.	None displayed
2	Refer to Figure 3-1 to connect SFC to the transmitter.	
3	Turn on the power switch of the SFC and press the  key.	<div style="border: 1px solid black; padding: 5px; width: fit-content; margin-bottom: 10px;">LOOP IN MANUAL ?</div> <div style="border: 1px solid black; padding: 5px; width: fit-content;">PRESS ID</div>
4	Press the  key. ~Note • “DSTJ” is an abbreviation commonly used at Yamatake Corporation to indicate a pressure / differential pressure transmitter. Because this product and a DSTJ3000 (the trade name that is used in Japan instead of ST3000) use the same communication system, “DSTJ” is displayed on the screen. • The tag number is set to XXXXXXXX at the time of shipment.	<div style="border: 1px solid black; padding: 5px; width: fit-content;">DSTJ TAG NO. LIN GP XXXXXXXX</div>

Displaying and changing the tag number

procedure

Display or change the tag number by using the following procedure. The example here is for the case of changing FIT-1234 to ABC-5678.



Step	Description	SFC screen
1	<p>Press the  key.</p> <ul style="list-style-type: none"> • If you want to confirm the tag number, press the  key to cancel this procedure. • If you want to change the tag number, proceed to step 3. 	<div style="border: 1px solid black; padding: 5px; width: fit-content;"> DSTJ TAG NO. LIN GP FIT-1234 </div>
2	<p>Press keys ,  and  in that order.</p> <p>~Note <i>If the wrong key is pressed, move the cursor backward by pressing the  key then the  key and then press the  key again. Then restart the input.</i></p>	<div style="border: 1px solid black; padding: 5px; width: fit-content;"> DSTJ TAG NO. LIN GP ABC </div>
3	<p>Press  key and then the  key.</p>	<div style="border: 1px solid black; padding: 5px; width: fit-content;"> DSTJ TAG NO. LIN GP ABC - </div>
4	<p>Press keys ,  and  and  in that order.</p>	<div style="border: 1px solid black; padding: 5px; width: fit-content;"> DSTJ TAG NO. LIN GP ABC -5678 </div>

Step	Description	SFC screen
5	<p>Press the  key.</p> <p>~Note Pressing the  key before pressing the  key will take you back to the previously set tag number.</p>	<div data-bbox="1187 244 1460 336" style="border: 1px solid black; padding: 5px;">DSTJ TAG NO. WORKING...</div> <div data-bbox="1187 389 1460 481" style="border: 1px solid black; padding: 5px;">DSTJ TAG NO. LIN GP ABC -5678</div>
6	<p>Press the  key and then the  key.</p> <p>Result:</p> <ul style="list-style-type: none"> Data has been stored in the transmitter. 	<div data-bbox="1187 613 1460 705" style="border: 1px solid black; padding: 5px;">SHIFT-</div> <div data-bbox="1187 750 1460 842" style="border: 1px solid black; padding: 5px;">DSTJ FIT-1234 WORKING...</div> <div data-bbox="1187 893 1460 985" style="border: 1px solid black; padding: 5px;">DSTJ FIT-1234 DATA NONVOLATILE</div> <div data-bbox="1187 1037 1460 1128" style="border: 1px solid black; padding: 5px;">DSTJ FIT-1234 READY...</div>

Displaying the input pressure value

Procedure

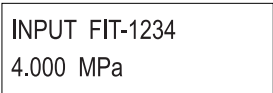

Display the pressure value applied to the transmitter using the following procedure:

Step	Description	SFC screen
1	Press the  key and then the  key. Result: • In this example, the pressure is set at 4 MPa {580 psi}	

Displaying the transmitted output (%)

Procedure

Display the output transmitted by the transmitter using the following procedure.

Step	Description	SFC screen
1	Press the  key. Result: • In this example, the output is 50% {580 psi}.	

Displaying or changing the upper and lower range values for range setting

Overview

Display or change the Upper Range Values (URV) and Lower Range Values (LRV) for range setting and the pressure corresponding to the desired span using the following procedure.





The following case is described here as an example:

- LRV: 0 MPa {0 PSI} changed to 2 MPa {290 PSI}
- URV: 5 MPa {725 PSI} changed to 7.5 MPa {1,088 PSI}
- Span: 5 MPa {725 PSI} changed to 5.5 MPa {798 PSI}











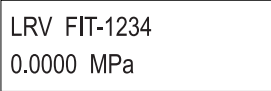

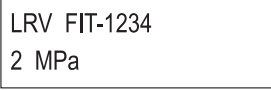
- ~Note**
- *Span is automatically determined as the difference between Upper and Lower Range Values. The span is displayed but cannot be changed directly.*
 - *When changing the Upper and Lower Range Values for range setting, be sure to change the LRV first and then URV.*

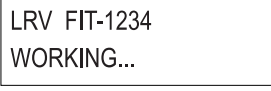
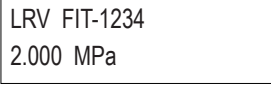

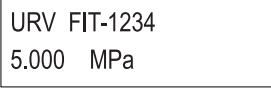
Displaying the set range

Displaying the set range.

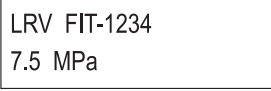
Step	Description	SFC screen
1	<ul style="list-style-type: none"> • Press the  key to display the LRV. • Press the  key to display the URV. • Press the  key to display the span. 	<div style="border: 1px solid black; padding: 5px; margin-bottom: 10px;">LRV FIT-1234 0.0000 MPa</div> <div style="border: 1px solid black; padding: 5px; margin-bottom: 10px;">URV FIT-1234 5.000 MPa</div> <div style="border: 1px solid black; padding: 5px;">SPAN FIT-1234 5.0000 MPa</div>
2	<p>~Note • <i>If the displayed data is correct, press the  key to confirm.</i></p> <ul style="list-style-type: none"> • <i>If the displayed data needs to be changed, proceed to the next procedure to change the set range.</i> 	<div style="border: 1px solid black; padding: 5px;">DSTJ FIT-1234 READY...</div>

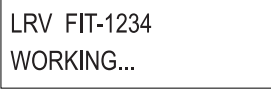
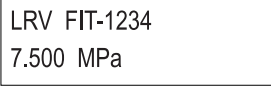
Changing the set range

Step	Description	SFC screen
1	Press the  key to change the LRV.	
2	Press the numeric key,  .	
3	Press the  key. Result: <ul style="list-style-type: none"> The LRV has been set at 2 MPa {290 psi} 	 
4	When changing the URV, press the  key.	
5	Press the numeric keys,  ,  and  in that order.	
6	Press the  key. Result: The URV has been set at 7.5 MPa {1,088 psi}	 

Step	Description	SFC screen
7	<p>Press the  and  keys in that order.</p> <p>Result: The data has been stored in the transmitter.</p>	<div data-bbox="1187 244 1460 333" style="border: 1px solid black; padding: 5px; margin-bottom: 10px;">SHIFT-</div> <div data-bbox="1187 389 1460 479" style="border: 1px solid black; padding: 5px; margin-bottom: 10px;">DSTJ FIT-1234 WORKING...</div> <div data-bbox="1187 535 1460 624" style="border: 1px solid black; padding: 5px; margin-bottom: 10px;">DSTJ FIT-1234 DATA NONVOLATILE</div> <div data-bbox="1187 680 1460 770" style="border: 1px solid black; padding: 5px;">DSTJ FIT-1234 READY...</div>

Displaying or changing the engineering units





By pressing the [] key, you can display the EU (Engineering Unit) in the order shown below.

Available engineering units are as follows.

- kPa - Mpa - hPa - Pa - mbar - bar - inH₂O - inHg - PSI - mmH₂O - mH₂O - kg/cm² - g/cm² - mmHg - kPa (return)
- (When the SFC uses the SI units by default)

Procedure

Display or change the EU using the following procedure. Here we describe an example of displaying the EU of kPa.

Step	Description	SFC screen
1	Press the  key.	
2	If you want to use some other EU, press either the  key or  key until the desired EU is displayed on the screen. Pressing the  key once will bring you back to the previous choice of EU.	

Displaying or changing the damping time constant

Overview

Depending on the conditions of the fluid process, pulsating pressure sometimes cause the output from the Transmitter to become unstable, making it difficult to read the measured value. When this happens, using a larger damping time constant can eliminate the small fluctuations in the measured pressure values to stabilize the output.

Available damping time constants







The available damping time constants are as follows. Each damping time constant will be displayed in either forward or backward order by pressing the keys as described below in the procedure. The actual response time will be delayed by about 0.4 seconds from the displayed value (time lose). The unit is “seconds.”

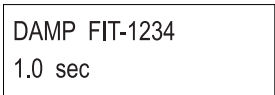

- 0.00 → 0.16 → 0.32 → 0.48 → 1.00 → 2.00 → 4.00 → 8.00 → 16.00 → 32.00

Procedure

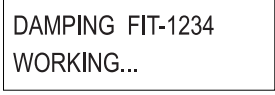
Display or change the damping time constant by following the procedure below. Here in this example, 1 second is set.

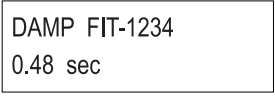
~Note *If the damping time constant needs to be changed, first select a value larger than the currently set value and see how the output fluctuates.*

Step	Description	SFC screen
1	Press the  key.	
2	To change the damping time constant, press either the  key or  key until the desired value appears on the screen. ~Note • When the  key is pressed, the display shown at the right appears on the screen. • When the  key is pressed, the display shown at the right appears on the screen.	  

Step	Description	SFC screen
3	<p>First press the  key and then press the  key.</p> <p>Result: The data has been stored in the transmitter.</p>	<div data-bbox="1093 244 1366 336" style="border: 1px solid black; padding: 5px; margin-bottom: 10px;">SHIFT-</div> <div data-bbox="1093 389 1366 481" style="border: 1px solid black; padding: 5px; margin-bottom: 10px;">DSTJ FIT-1234 WORKING...</div> <div data-bbox="1093 533 1366 624" style="border: 1px solid black; padding: 5px; margin-bottom: 10px;">DSTJ FIT-1234 DATA NONVOLATILE</div> <div data-bbox="1093 676 1366 768" style="border: 1px solid black; padding: 5px;">DSTJ FIT-1234 READY...</div>

Displaying the direction of output overshooting when an abnormal condition occurs

Abnormal conditions

There are three different burnout functions for signaling the abnormal conditions in the Transmitter:





- Non-burnout method : The pressure gauge outputs an abnormal value.
- Burnout up method : The pressure gauge is forced to overshoot to its upper limit, no matter what value is inputted.
- Burnout down method : The pressure gauge is forced to overshoot to its lower limit, no matter what value is inputted.

The PTG Series Transmitter is designed to use non-burnout method. Even if an abnormal condition occurs in the pressure gauge, the abnormal status can be displayed by operating the SFC, providing full information on the status. If the abnormal condition recovers, the normal value is automatically outputted.

~Note *If abnormal conditions are encountered, a message is displayed in the data display window of the SFC, regardless if the product has the burnout function or not.*

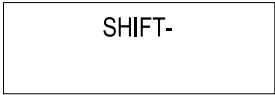
Procedure

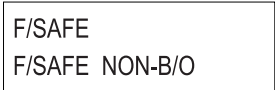
Confirm the direction of output overshooting in the event of burnout by performing the following.

Step	Description	SFC screen
1	Press the  key.	
2	Press the  key. • If the non-burnout method is used, “NON-B/O” will appear.	
3	Press the  key.	







Displaying the manufacturing number (PROM NO.)

Overview

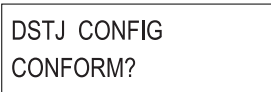
Although the manufacturing number of this product (PROM NO.) is shown on the identification plate, you can also check it from the SFC.

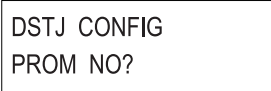
Procedure

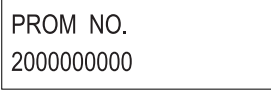

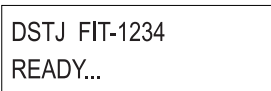



Check the manufacturing number (PROM NO.) using the following procedure. Here we have the manufacturing number as being 2000000000.

Step	Description	SFC screen
1	Press the  key.	
2	Press the  key twice.	
3	Press the  key.	
4	After checking the manufacturing number (PROM NO.), press the  key twice.	

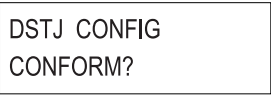
Displaying the temperature of sensor

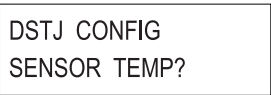
Procedure

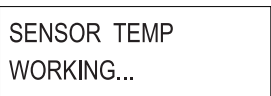
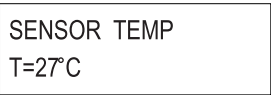
Check the temperature at the sensor section using the following procedure. The temperature at the sensor section given here is 27°C {81°F}.

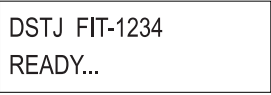
Step	Description	SFC screen
1	Press the  key.	
2	Press the  key three times.	
3	Press the  key. Result: The temperature at the sensor section is displayed.	 
4	After checking the temperature, press the  key twice.	





Displaying the software version

Procedure

Check the software version as follows. The software version given here is 7.1.

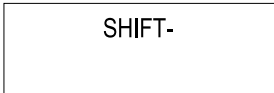
SFC : 7.1

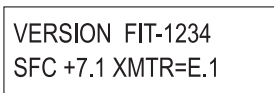
PTG7_0 : E.1

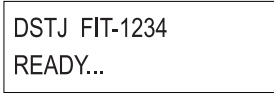
Step	Description	SFC screen
1	Press the  key.	
2	Press the  key. ~Note • <i>If the SFC is not in communication with the transmitters, the display shown at right will appear.</i> • <i>If the SFC is in communication with the transmitter, the display shown at the right will appear.</i>	 
3	After checking the software version, press the  key.	

Printing function (Optional)

Printing

There are two kinds of printing functions, and they both use different keys.

- Maintenance printing





Using the maintenance printing function, you can print out the data stored in the Transmitter (tag number, damping time constant, output range, pressure, output value, etc.).

- Action printing

Using the action printing function, you can print the responses of the Transmitter each time you operate the SFC keys.

Feeding the form

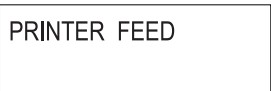
Feed in the paper roll as follows.

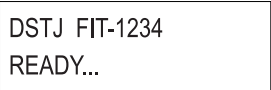
Step	Description	SFC screen
1	<p>Press the  and  keys in that order.</p> <p>Result:</p> <p>Each time you press the  key, the recording form will be advanced by one line.</p>	
2	<p>Press the  key to cancel the paper feeding function.</p> <p>Result:</p> <p>“PRINTER FEED” disappears and the display revert to the initial screen.</p>	







Printing function: Printing out data stored in the transmitter (Maintenance printing)

To print out data stored in the transmitter

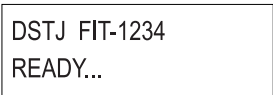
This printing function is used to record the settings of the Transmitter and the status of functional problems (specifically, to print the tag number, damping time constant, output range, pressure, output value, results of self-diagnosis and other data.)

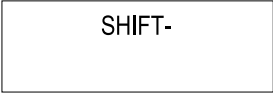
Procedure

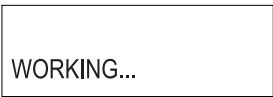
Print out the data stored in the Transmitter as follows.

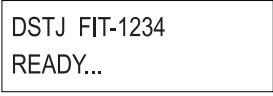
Step	Description	SFC screen
1	Press the  key.	
2	Press the  key.	
3	Press the  key. Result: Printing starts.	  

Example of maintenance printing

Figure 6-4 shows how the data printouts and what each line means.

Example of data printout	Meaning
'97-08-01 02:22	Date, time
TAG No. FIT 1234	Tag Number
TYPE : GAUG. PRESSURE	Type of Transmitter
ANA/DE : ANALOG XMTR	Output signal mode
FORM : LINEAR	Output signal form
PROM # : 2174925012	PROM number
SW VER : E.1	Software Version
DAMP : 0.00 sec.	Damping Time Constant
SPAN : 4.000 MPa	Span
LRV : 0.0000 MPa	Lower Range Value
URV : 4.000 MPa	Upper Range Value
URL : 10 MPa	Upper Range Limit
F/SAFE : NON-B/O	Direction of burnout
DISPLAY	Setting of digital indicator (optional)
CONF : LINEAR	(Note: Data will print out regardless of an optional digital indicator.)
TYPE : ENG UNIT	
EULO : 10.000	Engineering Unit, Lower Range Value
EUHO : 90.00	Engineering Unit, Upper Range Value
INPUT : 0.0012 MPa	Transmitter input pressure
OUTPUT : 0.02%	Transmitter output (%)
SV : T = 24°C	Sensor Temperature
STATUS CHECK = OK	Results of self-diagnosis

Figure 6-4 Example of maintenance printing

Printing function: Continuous printing (Action print)











Action print

This printing function is used to continuously print out data on the responses of the Transmitter each time the SFC keys are used. If you want the data for your record, this printing function may be used.

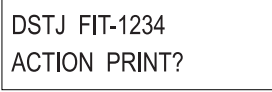
Procedure

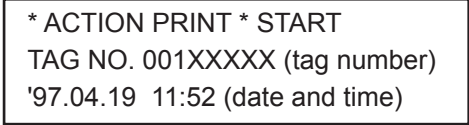
Action Print can be followed as below.

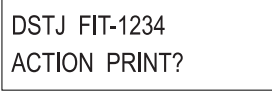
~Note *This procedure can be performed during measurement.*

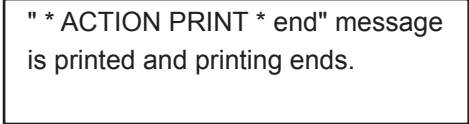
Step	Description	SFC screen
1	Press the  key.	
2	Press the  and  keys in that order.	
3	Press the  key. Result: What is shown below is printed.	
4	From this step onward, the responses of the transmitter will be printed out each time the SFC keys are operated.	
5	To cancel this printing function, press the  and  keys in that order.	
6	Press the  key. Result:	

Example of action printing

Pressing the keys as shown at left will produce the printout shown at right.

Key operation

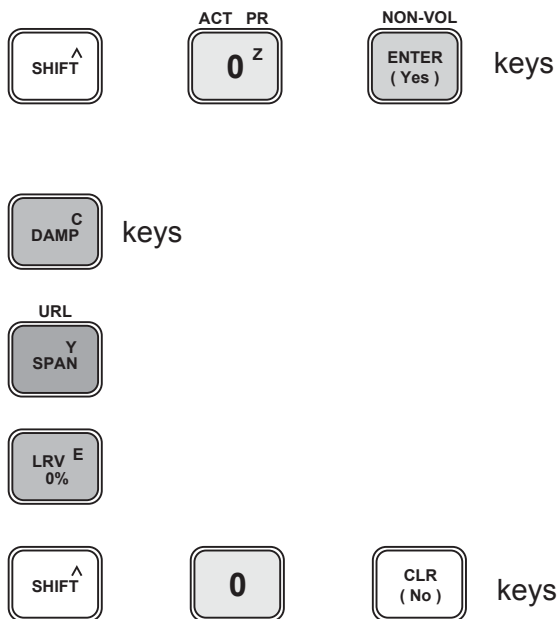

Printing example of corresponding action printout

```

* ACTIONPRINT * START
TAG. No. PI-1234
'01. 07. 10 16:11

DAMP PI-1234
0.0 s

SPAN PI-1234
300.0 kPa

LRV PI-1234
0.000 kPa

* ACTION PRINT * END
    
```

Figure 6-5 Example of action printing







Output mode

Overview

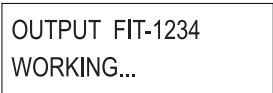
The output of the Transmitter can be set at a constant current in the range of 4mA (0%) to 20 mA (100%). The setting of the constant current is done in the output mode. This function is convenient for performing a loop check.

Procedure



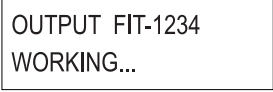
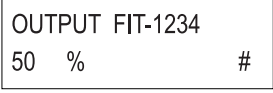

Set the constant current source mode by following the procedure below. Here in this example, the output is set at 50% (12mA).

Step	Description	SFC screen
1	Press the  key. Result: The current output is displayed.	 
2	Press the numeric keys  and  keys in that order.	
3	Press the  key. Result: This product outputs 12 mA (50%) ~Note The # symbol indicates that it is in constant current source mode.	 

Canceling the output mode

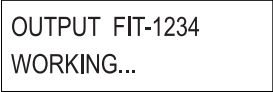
Procedure







Cancel the output mode by the following procedure.

Step	Description	SFC screen
1	Press the  key. Result: The current output is displayed.	 
2	Press the  key. Result: The constant current mode has been cancelled. ~Note <i>Check to ensure that the # symbol disappears.</i>	 

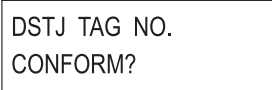
Checking the display format (Linear output) of the Indicator (Optional)

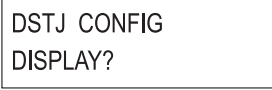
Procedure

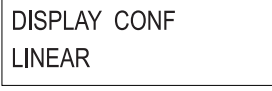
Check the display format of the transmitter using the following procedure.

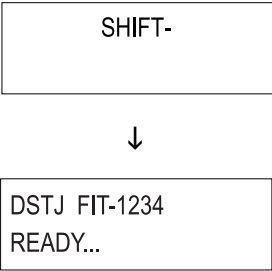
Step	Description	SFC screen
1	Press the  key.	
2	Press the  key.	
3	Press the  key.	
4	Press the  and  keys in that order.	











Checking and changing the display format (Engineering unit, % display) of the indicator

The indicator can be set to either selected engineering unit or % display.

Here is the procedure for checking and changing the display format.

Procedure

Check the display format of the indicator using the following procedure.

Step	Description	SFC screen
1	<p>Press keys , ,  and</p> <p>.</p> <p>You can now check the currently set display format (either selected EU or % display).</p>	<div style="border: 1px solid black; padding: 5px; width: fit-content; margin-bottom: 10px;">DISPLAY TYPE % (0.0)</div> <p style="text-align: center;">or</p> <div style="border: 1px solid black; padding: 5px; width: fit-content;">DISPLAY TYPE ENG. UNIT (3.5 FIG)</div>
2	<p>~Note • <i>If you want to change the currently set display format, press the  and  keys and proceed to step 3.</i></p> <p>• <i>If you want to confirm the currently set display format, press the  key twice.</i></p>	
3	<p>Press the  key.</p> <ul style="list-style-type: none"> The display format of the SFC has been changed. (The display format of the transmitter is not changed.) 	<div style="border: 1px solid black; padding: 5px; width: fit-content;">DISPLAY TYPE ENTERED IN SFC</div>
4	<p>Press the  and  keys in that order.</p> <ul style="list-style-type: none"> The display format of the transmitter is now changed. 	<div style="border: 1px solid black; padding: 5px; width: fit-content; margin-bottom: 10px;">DISPLAY DOWNLOAD DATA?</div> <div style="border: 1px solid black; padding: 5px; width: fit-content;">DISPLAY DATA LOADED</div>
5	<p>Press the  key twice.</p>	<div style="border: 1px solid black; padding: 5px; width: fit-content;">DSTJ FIT-1234 READY...</div>















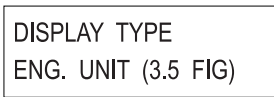

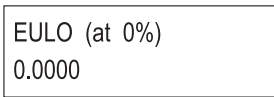
Checking or changing the upper and lower range values on the indicator





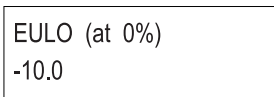

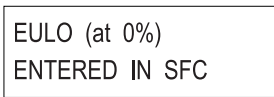
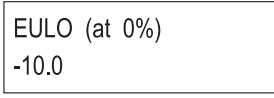

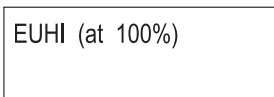



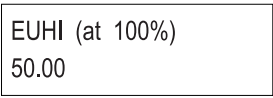

Overview

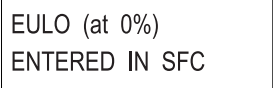
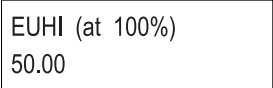
URV and LRV for the engineering unit can be set on the indicator by following the procedure below.

Procedure

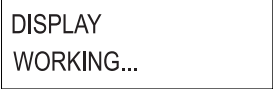
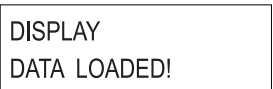
Set URV and LRV (EULO and EUHI) on the indicator by following the procedure.

Step	Description	SFC screen
1	Press keys  ,  ,  and  keys. <ul style="list-style-type: none"> • Check to see if the scale on the indicator is calibrated in the specified EU. 	
2	Press the  key. <ul style="list-style-type: none"> • In step 4 and 5, enter LRV of -10.0 for the EU. 	
3	Press the  ,  ,  ,  and  keys in that order.	
4	Press the  key. <ul style="list-style-type: none"> • One LRV for EU (-10.0) has been entered. 	 <p style="text-align: center;">↓</p> 
5	Press the  key. <ul style="list-style-type: none"> • In steps 7 and 8, enter an URV of 50.0 for EU. 	

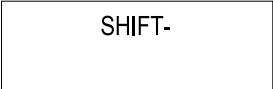
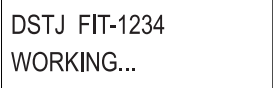
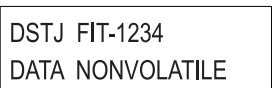
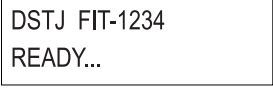







Step	Description	SFC screen
6	Press the  ,  ,  and  keys in that order.	
7	Press the  key. <ul style="list-style-type: none"> The URV for EU (50.0) has been entered. 	 <p style="text-align: center;">↓</p> 
8	Press the keys  and  . <ul style="list-style-type: none"> The URV and LRV for EU have been changed to the specified values. 	  <p style="text-align: center;">↓</p> 
9	Press the  and  key in that order.	<p style="text-align: center;">↓</p>
10	Press keys  and  in that order. <ul style="list-style-type: none"> The data has been stored in the transmitter. 	  <p style="text-align: center;">↓</p>  

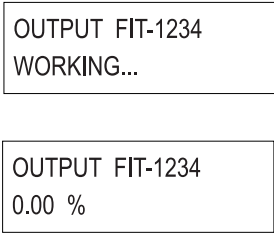

6-2 : Calibration by SFC

Verify the output signal

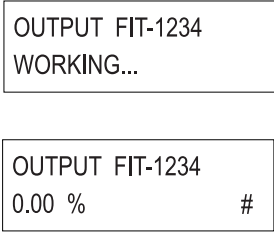
Procedure

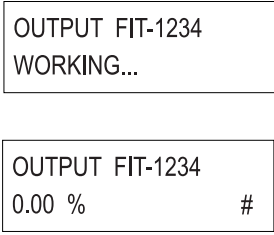
Use the following steps to put the transmitter into the Output Mode, and verify that the transmitter is operating properly and able to transmit a 0 and 100% output signal.







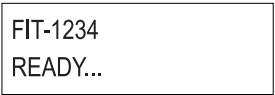

Step	Description	SFC screen
1	Press the  key. Result: • The current output is displayed on the screen.	
2	Press the  key. (if the output is set at 100%, press keys  ,  and  .)	
3	Press the  key. Result: The transmitter is now in the 4-mA (20-mA) constant current source mode.	
4	Check to see that the reading on the amperemeter is 4mA (20mA).	
5	Press the  key.	

Step	Description	SFC screen
6	<p>Press the  key.</p> <p>~Note</p> <ul style="list-style-type: none"> • If the reading on the amperemeter is 4mA (20mA), proceed to step 9. • If the reading on the amperemeter is less than 4mA (20mA), proceed to step 7. • If the reading on the amperemeter is greater than 4mA (20mA), proceed to step 8. 	<div data-bbox="1187 244 1460 333" style="border: 1px solid black; padding: 5px;"> OUTPUT FIT-1234 CORRECT DAC ZER # </div>
7	<p>Press the  key.</p> <ul style="list-style-type: none"> • After pressing the key once, check the reading on the amperemeter. • Press the key until the reading becomes 4mA (20mA). • When the reading becomes 4mA (20mA), proceed to step 9. 	<div data-bbox="1187 736 1460 826" style="border: 1px solid black; padding: 5px;"> OUTPUT FIT-1234 WORKING... </div> <div data-bbox="1187 882 1460 972" style="border: 1px solid black; padding: 5px;"> OUTPUT FIT-1234 INCREASED 4mA # </div> <div data-bbox="1187 1028 1460 1117" style="border: 1px solid black; padding: 5px;"> OUTPUT FIT-1234 CORRECT DAC ZER # </div>
8	<p>Press the  key.</p> <p>After pressing the key once, check the reading on the amperemeter. Press the key until the reading becomes 4mA (20mA).</p>	<div data-bbox="1187 1187 1460 1276" style="border: 1px solid black; padding: 5px;"> OUTPUT FIT-1234 WORKING... </div> <div data-bbox="1187 1332 1460 1422" style="border: 1px solid black; padding: 5px;"> OUTPUT FIT-1234 DECREASED 4mA # </div> <div data-bbox="1187 1478 1460 1568" style="border: 1px solid black; padding: 5px;"> OUTPUT FIT-1234 CORRECT DAC ZER # </div>
9	<p>Go to “Saving the calibrated values and canceling the Output Mode” on page 6-32.</p>	

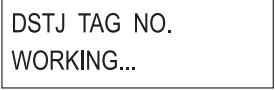
Saving the calibrated values and cancelling the Output Mode

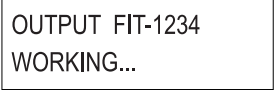
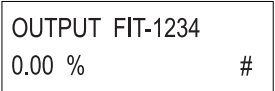
Procedure

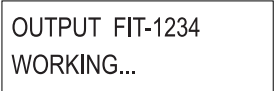
Save the calibrated values and cancel the Output Mode using the following procedure.

Step	Description	SFC screen
1	Press the  key.	
2	Press keys  and  . Result: *Data storage has been completed.	 
3	Press the  key. Result: The display on the right is shown on the screen, indicating that the current output is 0% (100%).	 
4	Press the  key. Result: The # symbol disappears, indicating that the Output Mode has been cancelled.	 

Calibrating the set range by inputting the actual pressure

Overview

This section describes how to calibrate URV and LRV for the set range by inputting a reference pressure into the Transmitter using the SFC.

Calibrate the LRV first and then URV.

Calibration devices

Generally, the calibration devices listed below are required:

- Reference pressure generator : A generator capable of producing pressure over a range of measurement close to that of the transmitter to be tested.
- Accuracy : $\pm 0.05\%$ F.S. or $\pm 0.1\%$ (whichever is larger)
- Power supply : 24 V DC
- Standard resistor : $250\ \Omega \pm 0.005\%$
- Voltmeter : Digital voltmeter (10 V DC range) with an accuracy of $\pm 0.02\%$ rdg + 1dgt
- SFC

Requirements for calibration



CAUTION

When conducting the actual-pressure calibration, the following requirements must be satisfied:

- The calibration must be conducted in a testing laboratory where there is no wind.
 - The standard temperature is 23°C { 73°F } and the standard humidity is 65%. Room temperatures from 15°C { 59°F } to 35°C { 95°F } and room humidity from 45% to 75% are acceptable as long as the result of measurement is not influenced.
 - It is best if the accuracy of the measuring instruments to be four times greater than that of the Transmitter.
-

Assembling the calibration devices

Connect the calibration devices as shown below:

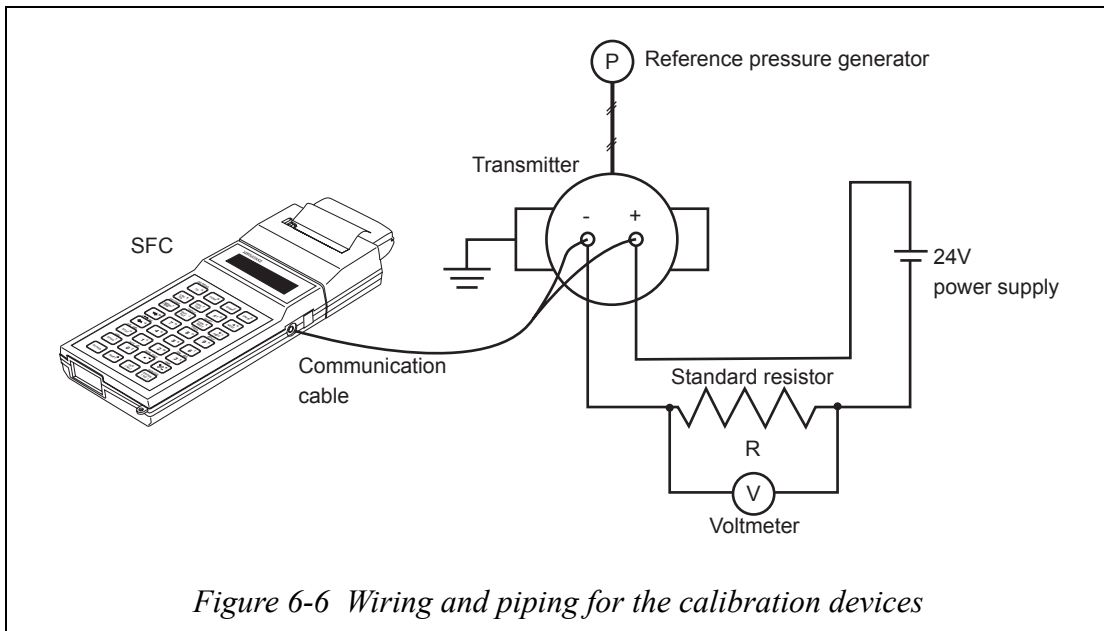



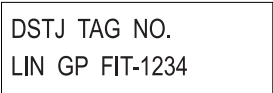



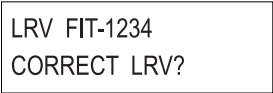

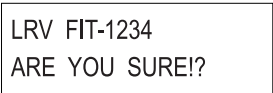
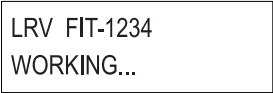
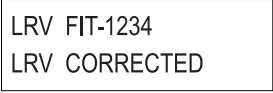

Figure 6-6 Wiring and piping for the calibration devices



Calibrating the lower range value

Procedure

Calibrate the LRV of actual pressure using following procedure. This procedure is followed when normal communication between the SFC and the Transmitter has been established.

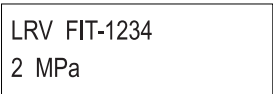
In this procedure, 2 MPa {290 psi} has been defined as the LRV.

Step	Description	SFC screen
1	Press the  key.	
2	Apply pressure so that the pressure reading on the reference pressure generator's pressure gauge read 2 MPa {290 psi}.	
3	Press the  key. <ul style="list-style-type: none"> The LRV that the transmitter has stored in memory is displayed. 	
4	Press the  key.	
5	Press the  key twice. Result: The LRV is calibrated to the current input pressure of the transmitter.	  
6	Press the  key. <ul style="list-style-type: none"> The display shown at the right appears on the screen, confirming the LRV stored in the transmitters memory. 	









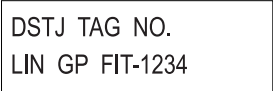

Step	Description	SFC screen
7	<p>Press the  and  keys in that order.</p> <p>Result:</p> <ul style="list-style-type: none"> The calibrated LRV is saved in the transmitter. 	<div data-bbox="1093 244 1366 333" style="border: 1px solid black; padding: 5px; margin-bottom: 10px;">SHIFT-</div> <div data-bbox="1093 389 1366 479" style="border: 1px solid black; padding: 5px; margin-bottom: 10px;">DSTJ FIT-1234 WORKING...</div> <div data-bbox="1093 535 1366 624" style="border: 1px solid black; padding: 5px; margin-bottom: 10px;">DSTJ FIT-1234 DATA NONVOLATILE</div> <div data-bbox="1093 680 1366 770" style="border: 1px solid black; padding: 5px;">DSTJ FIT-1234 READY...</div>

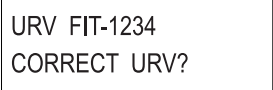

Calibrating the upper range value

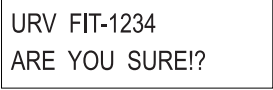
Procedure

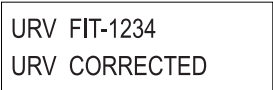
Calibrate the URV by following the procedure.

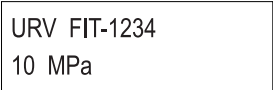
In the example below, 10 MPa {1,450 psi} has been defined as the URV.



Step	Description	SFC screen
1	Press the  key.	
2	Apply pressure so that the reference pressure generator's pressure gauge reads 10 MPa {1,450 psi}.	
3	Press the  key. <ul style="list-style-type: none"> The URV that the transmitter has stored in memory appears on the screen. (Here, 10 MPa {1,450 psi} is defined as the URV.) 	
4	Press the  key.	
5	Press the  key twice. Result: The URV is calibrated to the current input pressure of the transmitter.	  
6	Press the  key. <ul style="list-style-type: none"> The display at right appears on the screen, confirming the URV stored in the transmitter's memory. 	

Step	Description	SFC screen
7	<p>Press the  and  keys in that order.</p> <p>Result:</p> <ul style="list-style-type: none"> The calibrated URV is saved in the transmitter. 	<div data-bbox="1093 244 1366 333" style="border: 1px solid black; padding: 5px; margin-bottom: 10px;">SHIFT-</div> <div data-bbox="1093 389 1366 479" style="border: 1px solid black; padding: 5px; margin-bottom: 10px;">DSTJ FIT-1234 WORKING...</div> <div data-bbox="1093 535 1366 624" style="border: 1px solid black; padding: 5px; margin-bottom: 10px;">DSTJ FIT-1234 DATA NONVOLATILE</div> <div data-bbox="1093 680 1366 770" style="border: 1px solid black; padding: 5px;">DSTJ FIT-1234 READY...</div>

Resetting calibrated data

Procedure

Perform the following procedure to revert calibrated or entered values to the values pertaining before calibration or data entry.

Step	Description	SFC screen
1	Press the keys  and  in that order.	<div style="border: 1px solid black; padding: 5px; margin-bottom: 10px;">SHIFT-</div> <div style="border: 1px solid black; padding: 5px;">DSTJ FIT-1234 RESET CORRECTS?</div>
2	Press the  key. Result: About 2 seconds later, the display at right appears on the screen and the calibrated data will revert to the data stored at the time of delivery of the transmitter to the customer.	<div style="border: 1px solid black; padding: 5px; margin-bottom: 10px;">DSTJ FIT-1234 CORRECTS RESET #</div> <div style="border: 1px solid black; padding: 5px;">DSTJ FIT-1234 READY... #</div>







Erasing the # symbol

Overview

The # symbol appears when the calibrated or entered value has been reset to the initial value. This symbol can be erased by performing the following procedure. When doing so, use the actual pressure values. Therefore, input the actual pressure into the Transmitter by referring to “Calibrating the set range by inputting the actual pressure” on page 6-33.

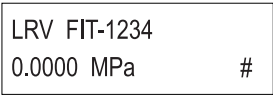

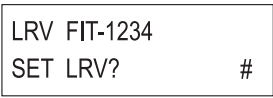

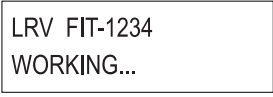
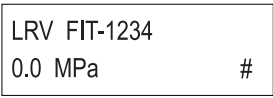





Setting LRV for actual pressure

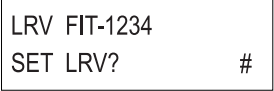

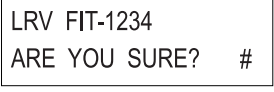
Set the LRV for actual pressure by performing the following procedure.

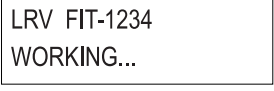
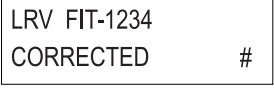
Step	Description	SFC screen
1	Set the actual pressure inputted into the transmitter to 0 MPa.	
2	Press the  key.	
3	Press  key.	
4	Press the  key. Result: <ul style="list-style-type: none"> The LRV is stored and displayed. 	 

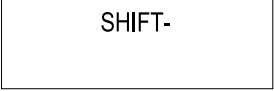
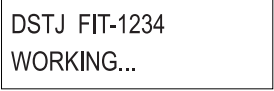
Calibrating the LRV of the actual pressure

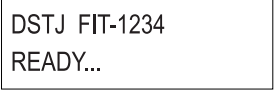
Calibrate the LRV of the actual pressure by performing the following procedure.

Step	Description	SFC screen
1	Press the  key.	
2	Press the  key.	
3	Press the  key.	
4	Press the  key. Result: • The LRV has been calibrated.	 
5	Press the keys  and  in that order. Result: * Data is stored in the memory.	   
6	Turn off the power to the transmitter and then turn it on again.	

Step	Description	SFC screen
7	Press the  key.	<div data-bbox="1094 244 1367 336" style="border: 1px solid black; padding: 5px;">DSTJ FIT-1234 WORKING...</div> <div data-bbox="1094 389 1367 481" style="border: 1px solid black; padding: 5px; margin-top: 10px;">DSTJ TAG NO. LIN DP FIT-1234</div>
8	Press the  key. The # symbol has disappeared.	<div data-bbox="1094 555 1367 647" style="border: 1px solid black; padding: 5px;">DSTJ FIT-1234 WORKING...</div> <div data-bbox="1094 701 1367 792" style="border: 1px solid black; padding: 5px; margin-top: 10px;">DSTJ FIT-1234 STATUS CHECK=OK</div>

6-3 : Self-diagnostic messages from SFC



Troubleshooting and verification of normal functioning

Verifying the normal functioning and self-diagnosis

Using the SFC, you can verify that the Transmitter is operating normally. If the Transmitter has trouble functioning, follow the self-diagnostic messages provided by the SFC. If abnormal conditions are encountered in the Transmitter, in the process, in the SFC or in the communication system during measurement, follow the self-diagnostic messages.

Procedure



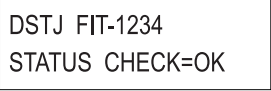
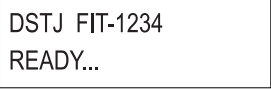



When verifying the normal functioning, connect the SFC to the Transmitter and perform the following procedure.

Step	Description	SFC screen
1	Press the  key. ~Note <ul style="list-style-type: none"> When the “STATUS CHECK=OK” message appears, the process of verifying normal functioning ends. When any message other than “STATUS CHECK=OK” appears, take an appropriate action by referring to the instructions given in the following pages. Proceed to step 2. 	
2	~Note <ul style="list-style-type: none"> Take an appropriate action by referring to the messages given on the following pages. If there is more than one message, each message will be displayed for about 2 seconds alternately. 	 

If abnormal conditions are encountered during communication

Message and action

If the “CRITICAL STATUS” message is displayed during communication, take the action given below.

Message	Action
<div data-bbox="347 510 624 607" style="border: 1px solid black; padding: 5px; margin-bottom: 10px;"> DSTJ FIT-1234 CRITICAL STATUS </div> <div data-bbox="347 689 624 786" style="border: 1px solid black; padding: 5px;"> PRESS STATUS! </div>	<p>Press the  key.</p> <p>Deal with the abnormal conditions encountered by following the displayed messages.</p> <p>~Note • Even if the “CRITICAL STATUS” message is displayed, three keys  ,  and  are still operable.</p> <ul style="list-style-type: none"> • After taking an action, press the  key to check that the “SELF-DIAGNOSIS RESULT OK” message is appears.
<div data-bbox="347 1173 624 1270" style="border: 1px solid black; padding: 5px; text-align: center;"> : </div>	<p>The battery power is becoming low. Follow the instructions given in the SFC operation manual (CM2-SFC100-2001).</p>
<div data-bbox="347 1341 624 1438" style="border: 1px solid black; padding: 5px; text-align: right;"> # </div>	<ul style="list-style-type: none"> • Press the  key. <p>Deal with the abnormal conditions by following the displayed messages.</p> <ul style="list-style-type: none"> • When the problem has been eliminated, the # symbol will disappear. • When the # symbol disappears, press the  key to display the “SELF-DIAGNOSIS RESULT OK” message.

Self-diagnostic message

Message

When abnormal conditions are encountered, press the  key and a self-diagnostic message will appear. The meaning of the messages and the actions to take are as follows.

If the abnormal condition seems to have occurred in the process, SFC or communication system:

Message	Description, cause	Action to take
NO XMTR RESPONSE	Receiving instrument does not respond.	<ul style="list-style-type: none"> Reperform the procedure for starting communication. Press the  key and look at the message. Check the connection of the loop and SFC.

If the abnormal condition seems to have occurred in the transmitter:

Message	Description, cause	Action to take
MDU/DAC COMP FLT	MDU/DAC Fault	Contact your Yamatake representative.
ROM FAULT	ROM Fault	Contact your Yamatake representative.

If abnormal conditions seem to have occurred in SFC or a communication system:

Message	Description, cause	Action to take
FAILED COMM CHK	Preface to a trouble message	
HI RES/LO VOLT	Extra-high loop resistance Extra-low voltage of a power supply	<ul style="list-style-type: none"> Adjust loop resistance. Increase the voltage of the power supply

Message	Description, cause	Action to take
ILLEGAL RESPONSE	Improper communication	Check the connection, wiring and power supplies.
LOW LOOP RES	Extra-low loop resistance value	Adjust the resistance value.
PRINTER FAIL!	Printer failure	Contact your Yamatake representative.
SFC FAULT	SFC Fault	<ul style="list-style-type: none"> Restart the procedure for starting communication. If the same message persists, contact your Yamatake representative.

If an operational mistake seems to have been made:

Message	Description, cause	Action to take
CORRECT LRV?	Was the correct value entered to set the range to 0%?	Verify the entered value. If a wrong value was entered, correct it.
CORRECT URV?	What value was entered to set the range to 100%?	Verify the entered value. If a wrong value was entered, correct it.
CORRECT RESET #	Calibration must be performed again.	Calibrate the URV and LRV of the range.
ENTRY>SENS RNG	The set value is 1.5 times greater than the URV of the range shown on a pressure gauge	After checking the value by pressing the  key, enter the correct value.
EXCESS SPAN COR #	Excessive span calibration	Calibrate the URV of the range.

Message	Description, cause	Action to take
EXCESS ZERO COR #	Excessive zero calibration	Calibrate the LRV of the range.
EXCESSIVE OUTPUT	Output value required in the constant current source mode is greater than output range (-1.25% to 105%).	After checking the value by pressing the  key, enter the correct value.
INVALID REQUEST	Operational mistake during the operation of the SFC	Check the SFC operation procedure.
NOT SUPPORT	Do not use the key(s) that were pressed.	Press the correct keys.

Insulation resistance test, voltage withstand test

Precautions

Generally, insulation resistance and voltage withstand tests are not required. If these tests are conducted, the built-in varistor for surge voltage absorption may be damaged. If these tests are absolutely necessary due to unavoidable circumstances, follow the specified test procedure very carefully.

Test procedure

1. Remove the external wires from the Transmitter.
2. Short-circuit the + and - SUPPLY terminals.
3. Tests must be conducted between these short-circuited terminals and the ground terminals.
4. Voltage to be applied and judgment criteria are shown below. To prevent damage to the instruments, voltages higher than the voltage values shown below should not be applied.

Judgement criteria

Voltage to be applied and judgment criteria are as follows.

Test	Judgement criteria
Insulation resistance test	More than $2 \times 10^7 \Omega$ at an applied voltage of 25 V DC ($25^\circ\text{C} \pm 5^\circ\text{C}$ { $77^\circ\text{F} \pm 9^\circ\text{F}$ }, less than 60% RH)
Voltage withstand test	50 V AC, 1 minute, current set at 2mA

Chapter 7 : Spare Parts

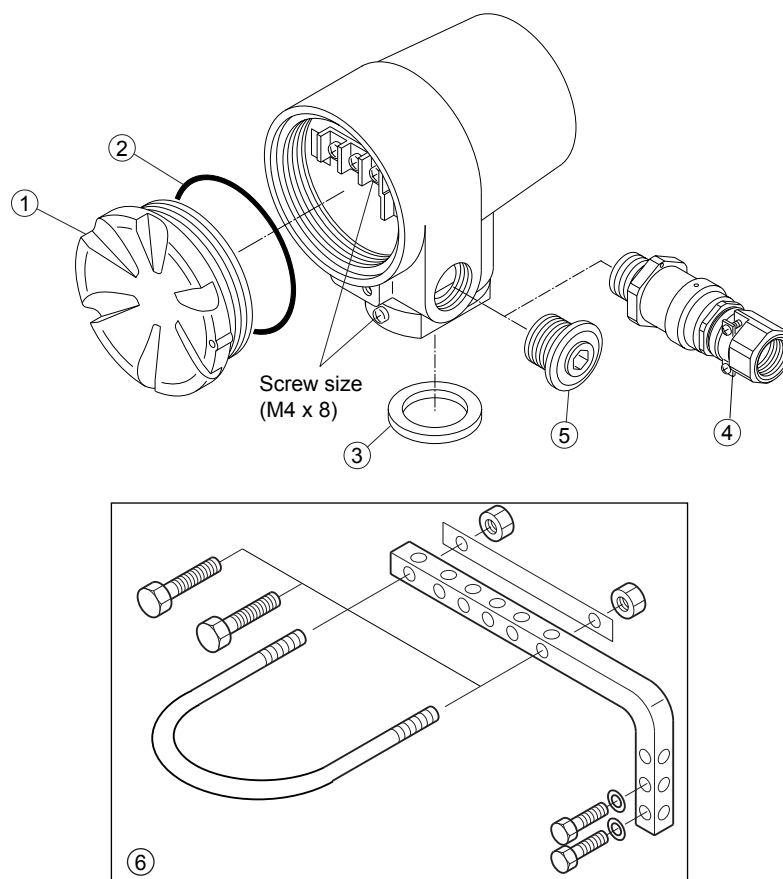

Figure 7-1 Exploded view

Table 7-1 Spare parts

No.	Parts description	Part number	Qty.	Unit
1	Case cover (with an O-ring)	80370406-001	1	1EA
2	O-ring	80020935-842	1	1-F
3	Gasket (for male screw)	80370122-001	1	1-F
	Gasket (for male screw)	80370122-002		
4	Pressure packing set	80370411-001	1	1EA
5	Plug (with an O-ring)	80381081-002	1	1EA
6	Mounting hardware	80370404-001	1	1EA
7	Unit seal set	80370187-001	1	1-F

Appendix - Operational Manual for HART® Communication (For Model PTG72)

Section 1 : Starting Communications

Instructions for connecting HART® Communicator to this transmitter.

Basic instructions for Key-pad operation.

1-1: Connecting Communicator

You connect the communicator directly to signal terminals on the transmitter's terminal block or at any location in the 4 to 20mA loop. (Polarity of the communicator connection does not matter)

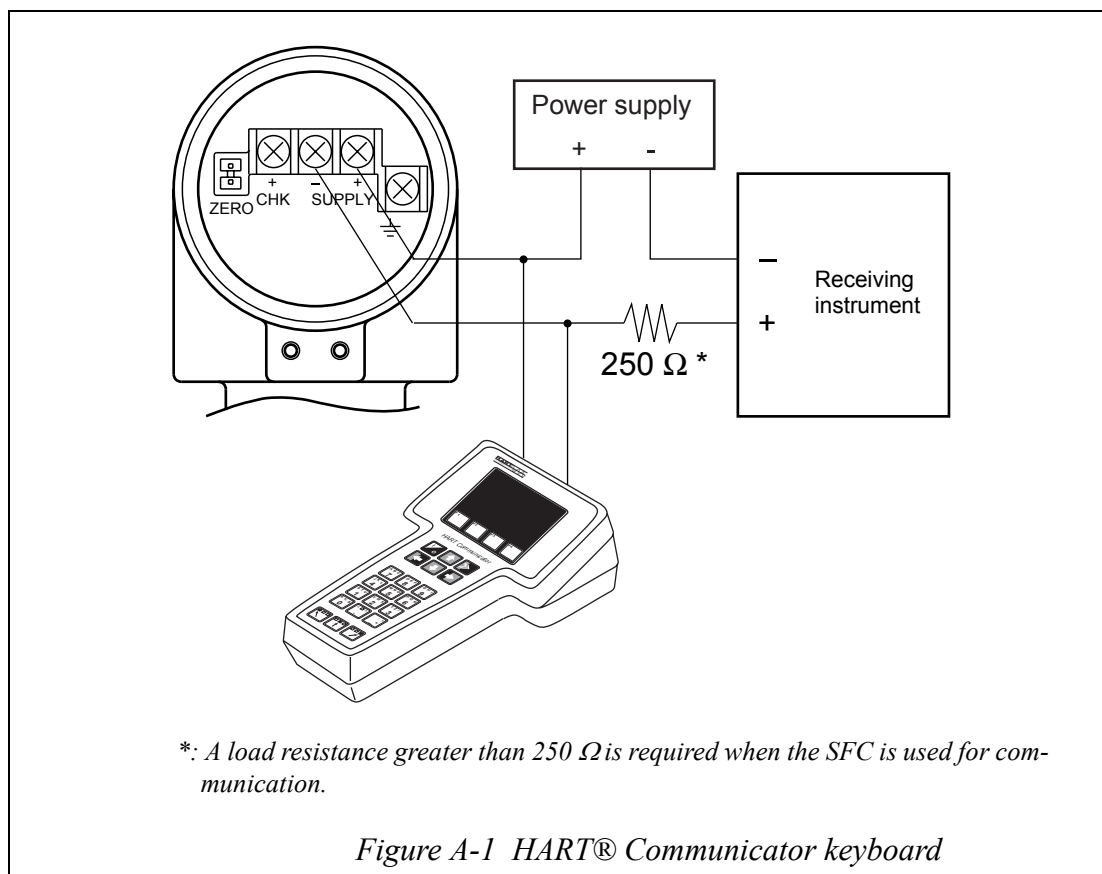

 CAUTION

Do not hook up the HART® Communicator to the bilingual S900 in “DE Enable” while the control loop is in the automatic mode.

When the HART® communicator is hooked up to the bilingual S900 in “DE Enable”, the transmitter output might trip due to the rush current generated by the big capacitance in the HART® communicator.

1-2: HART® Communicator Keyboard

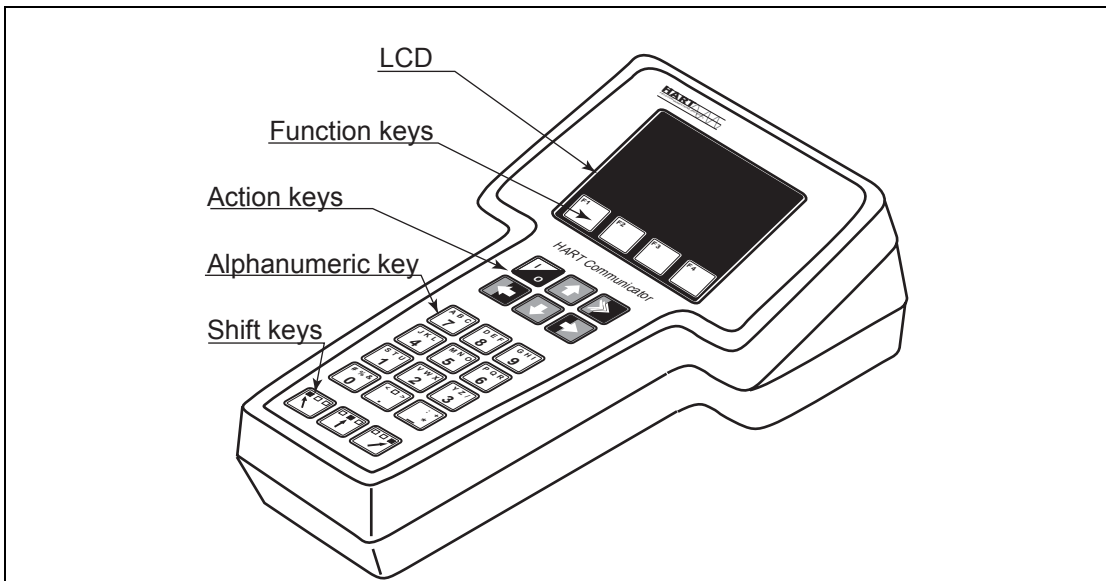

Figure A-2 HART® Communicator

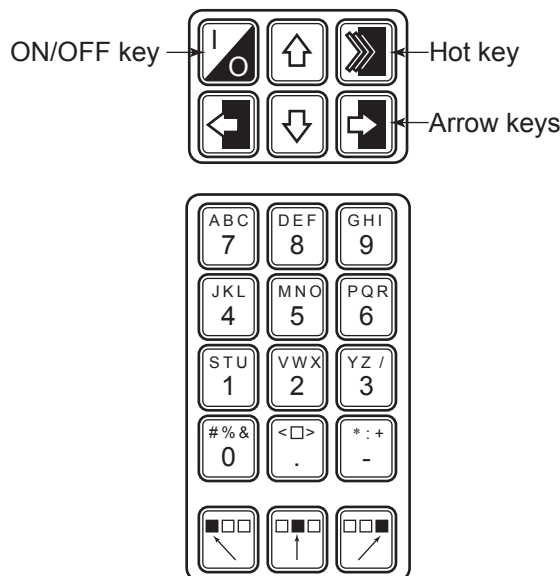





Figure A-3 HART® Communicator keyboard

1-3: Symbols on Communicator Screen

-  Flashing heart icon in the upper right corner indicates that the transmitter and communicator are communicating.
-  This left arrow symbol indicates that the left arrow on the keypad brings you back to previous menu.
-  These arrows indicate there is more column to scroll through, using the indicated arrow on the keypad.
-  This right arrow indicates a menu item has menu option.

1-4: Keying in Alphanumeric Characters

To key in an alphabet at the top of a key, press the arrow key indicating the position of the character on the key, then press the alphanumeric key.

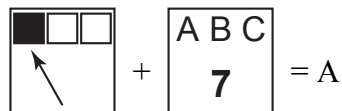

1-5: Establishing Communications

This procedure starts communications between the transmitter and the communicator:

STEP	Action and/or Description
1	Turn on communicator. The communicator runs a self-test check then determines if it is connected to a transmitter.
2	<p>If you receive a communication error message (No Device Found), check the following:</p> <ul style="list-style-type: none"> • Loop resistance: Is there a minimum of 250 Ω resistance between the communicator and the power supply? • Power supply: Is power applied? Is there greater than 11 volts at the transmitter? <p>Correct any problems, and try communicating again. If the message, or any other error message, appears again, refer to Section 7 - Trouble shooting for probable cause.</p>
3	<p>When the “Online” display - shown below - appears, you have established communication with the transmitter. The flashing heart icon in the upper right corner indicates the communicator and the transmitter are communicating.</p> <div data-bbox="683 1003 1150 1346" style="border: 1px solid black; padding: 10px; margin: 10px auto; width: fit-content;"> <p>PTG: TAG001 ♥</p> <p>Online ◀</p> <p>1 → Device setup</p> <p>2 PV 0.0005 psi</p> <p>3 AO 12.00 mA</p> <p>4 LRV -50.000 psi</p> <p>5 URV 50.000 psi</p> <p style="text-align: center;">SAVE</p> </div>

1-6: Checking Basic Data

This procedure checks the transmitter's factory-set configuration parameters:

STEP	Action and/or Description
1	From the “Online” menu, enter “Device setup” by pressing the right arrow (→) key on the communicator keypad.
2	<p>Press the down arrow (↓) key to scroll down to menu-item “5 Review”. When highlighted press the right arrow (→) key to enter review function.</p> <div data-bbox="775 539 1246 891" style="border: 1px solid black; padding: 10px; margin: 10px auto; width: fit-content;"> <pre> PTG: TAG001 REVIEW Model PTG [HELP] [PREV] [SAVE] [EXIT] </pre> </div>
3	<p>Press PREV and/or NEXT to scroll through the configuration data including:</p> <ul style="list-style-type: none"> • Model • Measurement type • Manufacturer • Pressure unit • URL (Upper Range Limit) • LRL (Lower Range Limit) • Damping • PV% Range • Transfer function (linear or square root) • PV URV (Upper Range Value) • PV LRV (Lower Range Value) • Analog output (in mA) • AO Alarm type • Sensor serial number • PROM ID • Device ID • Tag name • Message • Universal revision number • Field device revision number • Software revision number • Polling address • Number of required preambles
4	Press EXIT to go back to the “Device setup” menu.

Section 2 : Configuration

This section introduces you configuration of PTG transmitter with HART® option using the HART® Communicator.

This section also provides an overview of the HART® Communicator, including menus and keyboards.

2-1: HART® Communicator Menu Summary

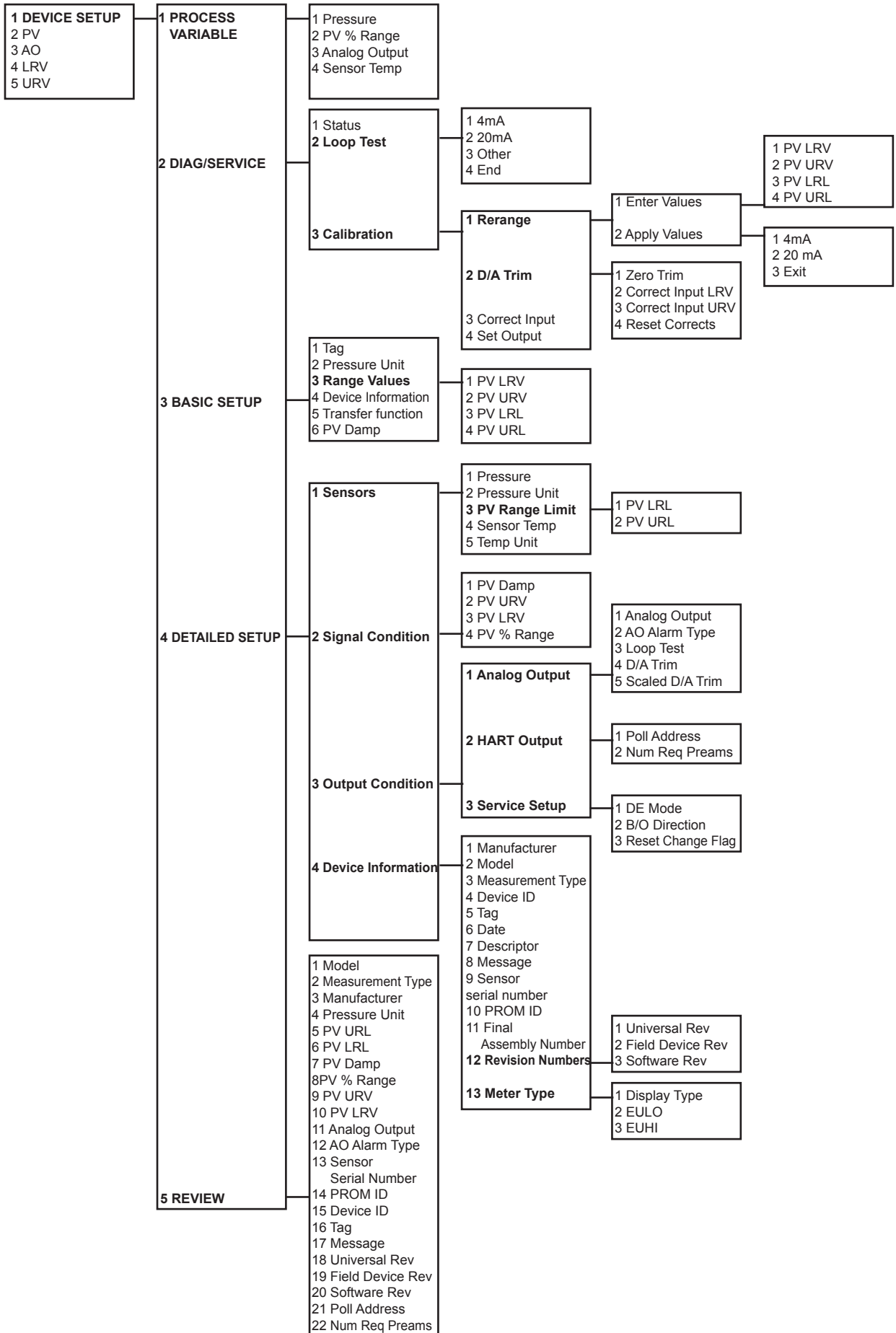

2-2: Changing Tag No.

This shows how to change or enter tag number.

(Device setup) - (Detailed setup) - (Device information) - (Tag)

After entering a tag number with pressing ENTER, press SEND to download the change to the transmitter.

2-3: Indicator Display Format

This shows how to configure display format and/or its ranges.

(Device setup) - (Detailed setup) - (Device information) -(Meter type)

PTG: TAG001

Meter Type

1 Display type

2 EULO

3 EUHI

SAVE
HOME

2-3-1: Display Type

Mode	Description
E.UNIT	Displaying PV with engineering unit (-19999EU ≤ PV ≤ +19999EU)
%	Displaying PV in % (-199.9% ≤ PV ≤ +199.9%)

2-3-2: EULO / EUHI

EULO and EUHI must be configured between -19999 and +19999 to indicate PV with an engineering unit.

EULO: The value to be indicated when the output is 0%

EUHI: The value to be indicated when the output is 100%

Displayed Value (EU) = PV (%) X (EUHI-EULO) + EULO

2-3-3: Over Range

The display will flash when the PV exceeds -1.25% or +105%.

2-4: Selecting unit of Measurement

This function is to select a pressure unit of the transmitter.

(Device setup) - (Basic setup) - (Pressure Unit)

A pressure unit is able to be selected from the following;

inH ₂ O	inHg	mmH ₂ O	mmHg	psi	bar
mbar	g/Sqcm	kg/Sqcm	Pa	kPa	
MPa					

2-5: Setting Range Values

This is to configure the measuring range of the transmitter.

(Device setup) - (Basic setup) - (Range values)

```

PTG: TAG001
Range Values
1→PV LRV 0.000 inH2O
2 PV URV 1.000 inH2O
3 PV LRL
4 PV URL

HELP HOME

```

Select PV LRV or PV URV to key in the desired setting. The measuring range can be set from -105% to +105% of URL.

Press ENTER. This takes you back to “Range values” menu.

Press SEND to download change to transmitter.

```

PTG: TAG001
Range Values
1→PV LRV 0.000 inH2O
2 PV URV 5.000 inH2O
3 PV LRL
4 PV URL

HELP SEND HOME

```

If the number of digit you key in is more than four, the set range is not appeared on “Range Values” menu.

LRL and URL are to refer only.

2-6: Adjusting Damping Time

You can adjust the damping time to reduce the output noise.

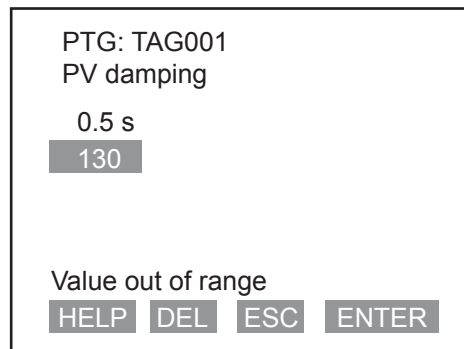

(Device setup) - (Detailed setup) - (Signal condition) - (PV damping)

When PV damping menu, key in appropriate damping time from 0.0 to 128.0, and the press ENTER. A display will prompt when you enter the value out of range that the value is out of range.



ATTENTION

The damping time set by HART® Communicator might not be corresponding to that which is displayed on the SFC. Reconfigure the damping time with SFC when the transmitter is used in the DE enable mode. (ref. 5.2 DE Mode)

Section 3 : Start-up and Operation

This section identifies how to access typical data associated with the start-up and the operation of model PTG with HART® communication option. It includes the procedure for running an analog output check

3-1: Running Analog Output Check

You can put the transmitter into a constant-current source mode, which maintains the output that is set between 4mA (0%) and 20mA (100%).

This shows how to configure the transmitter in a constant-current source mode and to return to its original output.

(Device setup) - (Detailed setup) - (Output condition) - (Analog output) - (Loop test)

You will be prompted to put the loop into manual mode. After doing so, press ENTER.

Then, the following screen is appeared.

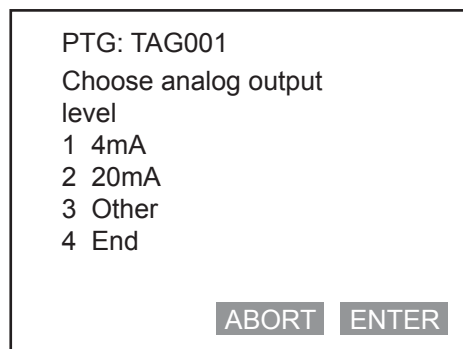

```
PTG: TAG001
Choose analog output
level
1 4mA
2 20mA
3 Other
4 End

ABORT ENTER
```

- Select 4mA to set the output signal level to 4mA (0%).
- Select 20mA to set the output signal level to 20mA (100%).
- Select Other and press ENTER, then use communicator's keyboard to enter other values.
- When the transmitter has the display, the PV which is set will flash.
- Select End and press ENTER. The communicator will notify you that it is returning transmitter to its original output.

3-2: Configuring Ranges with Applying Pressure

This shows how to configure ranges with applying 4mA / 20mA input pressure.

(Device setup) - (Diag/Service) - (Calibration) - (Rearrange) - (Apply Values)

You will be warned to remove the loop from automatic control. After doing so, press ENTER.

Then the following screen will be appeared.

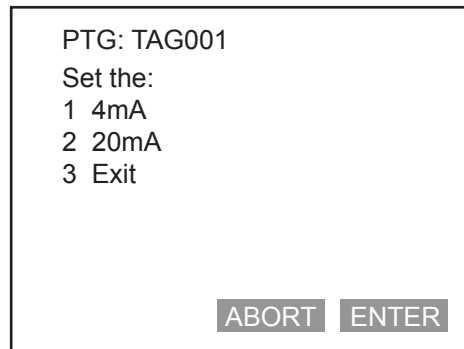

- Choose 4mA then press ENTER.

A display will prompt you to apply new 4mA input.

When “Current applied process value” display appears, choose “Set as 4mA value” then press ENTER.

Return the loop to automatic.

Section 4 : Calibration

This section provides information about calibrating the transmitter's analog output and measuring range. It also covers the procedure for resetting calibration to default values.

4-1: Calibrating Analog Output Signal

You can calibrate the transmitter's analog output circuit at its and 100% levels by using the transmitter in its constant-current source mode.

(Device setup) - (Detailed setup) - (Output Condition) - (Analog output) - (D/A trim)

STEP	Action/Description
1	<p>You will be warned to remove the loop from automatic control. After doing so, press OK.</p> <p>When prompt appears, connect a precision milliammeter or volt meter (0.03% accuracy or better) in loop to check readings. Press OK.</p>
2	<p>The following display prompts will appear:</p> <ul style="list-style-type: none"> • Setting field device output to 4 mA. Press OK. • Enter meter value. Key in meter value, then press OK. • Is field device output 4.000 mA equal to reference meter? <ul style="list-style-type: none"> 1 Yes 2 No <p>If not equal, select No, press ENTER, then key in new meter value. (returns to "Enter meter value" prompt until field device output equals reference meter.)</p> <p>If equal, select Yes, press ENTER.</p>
3	<p>The following display prompts will appear:</p> <ul style="list-style-type: none"> • Setting field device output to 20 mA. Press OK. • Enter meter value. Key in meter value, then press ENTER. • Is field device output 20.000 mA equal to reference meter? <ul style="list-style-type: none"> 1 Yes 2 No <p>If not equal, select No, press ENTER, then key in new meter value. (Returns to "Enter meter value" prompt until field device output equals reference meter.)</p> <p>If equal, select Yes, press ENTER.</p> <p>Prompt notifies you that the field device will be returned to its original output.</p>

4-2: Calibrating Range

The ST3000 Smart Transmitter has two-point calibration. This means when you calibrate two points in the range, all the points in that range adjust to that calibration.

(Device setup) - (Diag/Service) - (Calibration) - (Correct Input)

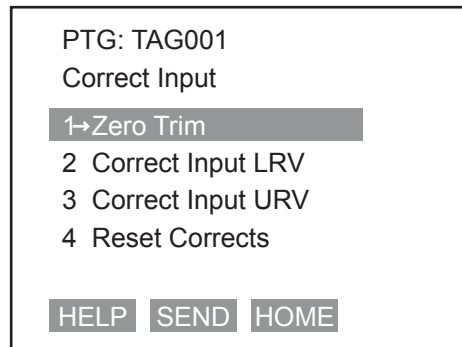

- Select “Correct Input LRV” or “Correct Input URV”.
- You will be warned to remove the loop from automatic control. After doing so, press OK.
- When prompted, adjust pressure source to apply pressure equal to LRV (0%) or URV (100%), then press OK.
- When pressure is stable, press OK.
- When prompted, remove pressure.

4-3: Resetting Calibration

A Corrects Rest returns the zero and span calibration factors to their default values. The transmitter calculates its output based on the characterization equation alone, without any compensation for the residual errors.

(Device setup) - (Diag/Service) - (Calibration) - (Reset Corrects)

- When prompted, remove the loop from automatic control. Press OK.
- Prompt notifies you that a Reset Corrects is about to occur. Press OK.
- When message “Reset Corrects OK” appears, press OK.
- Calibration is reset to default values.
- When prompted, return the loop to automatic control and press OK.

Section 5 : Service Setup Menu

Service Setup menu includes;

- DE Mode
- B/O Direction
- Reset Change Flag

To enter Service Setup menu, password number is required.

5-1: Entering Service Setup Menu

(Device setup) - (Detailed Setup) - (Output Condition) - (Service Setup)

When the prompt notifies you that password number is required, press OK.

Key in “3000” as the password number.

The following display will appear.

PTG: TAG001	
Service Setup	
1→DE Mode	DISABLE
2 B/O Direction	None
3 Reset Change Flag	
SEND HOME	

5-2: DE Mode

The model PTG with HART® communication option has capability to communicate with both HART® Communicator and SFC (Smart Field Communicator).

The function to communicate with SFC is disabled when the transmitter is shipped.

WARNING

Hooking up HART® Communicator with enabling the DE mode might cause output fluctuation.

Do not hook up the HART® Communicator “On Line” when the DE mode is enabled.

To enable the function, follow the procedure.

(Service Setup) - (DE Mode)

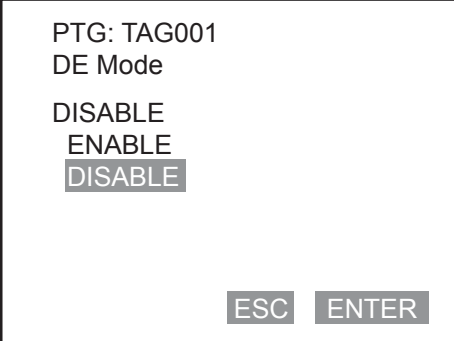

```
PTG: TAG001
DE Mode
DISABLE
ENABLE
DISABLE
ESC ENTER
```

Select ENABLE and press ENTER.

5-3: Failsafe Direction

The failsafe direction of the transmitter cannot be configured.

Document Number:	CM2-PTG300-2001
Document Name:	Smart Pressure Transmitter Model: PTG71/72 User's Manual
Date:	Aug. 2002 (First issue) Nov. 2002 (Rev. 1)
Issued/Edited by:	Yamatake Corporation

Yamatake Corporation

Totate international Building
2-12-19 Shibuya
Shibuya-ku, Tokyo 150-8316
Japan
Tel : 81-3-3486-2310
Fax : 81-3-3486-2593



Certificate No. Q17862



Certificate No. E8318
For Shonan Factory

YAMATAKE
Savemation

Saving through Automation