

**ST3000 Ace
Smart Transmitter
Electronic Differential Pressure
Transmitter
Model JTR929A/930A
JTE929A/930A
(Remote Diaphragm Seal Type)
User's Manual**

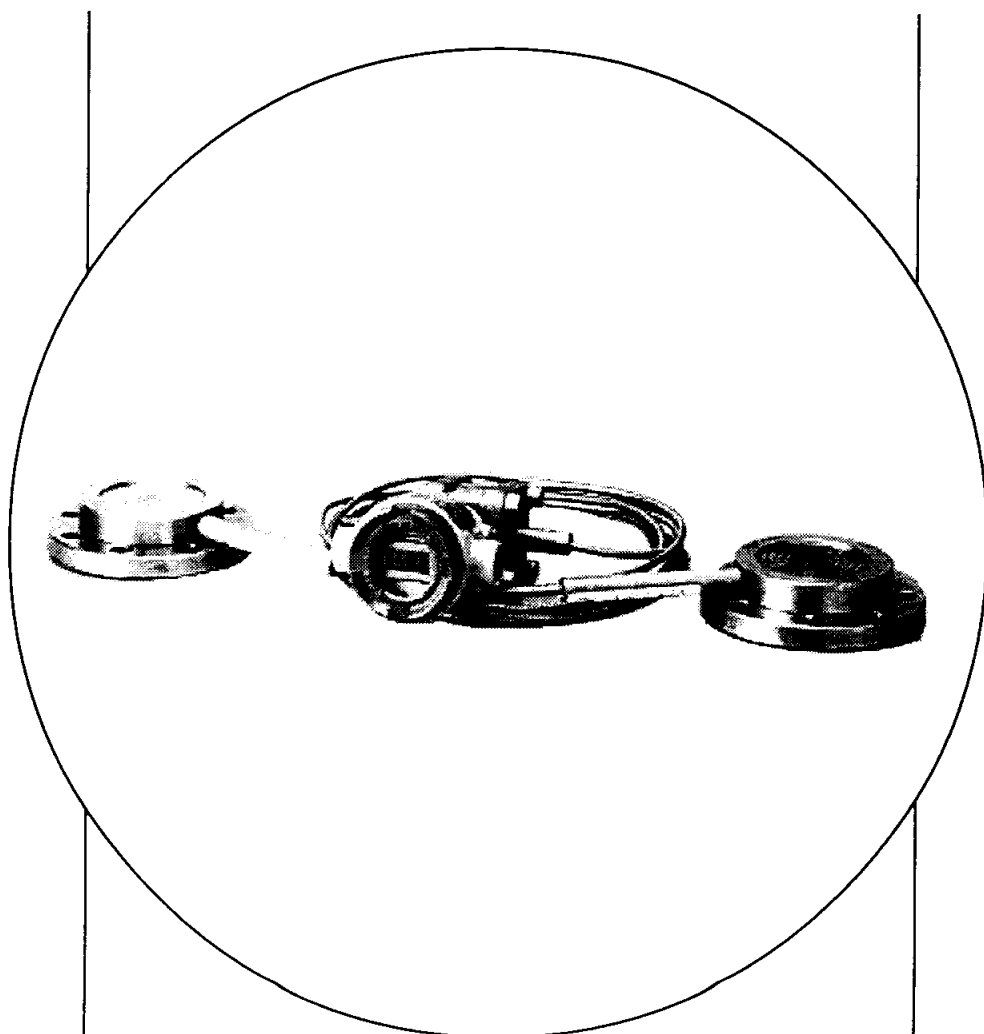

ST3000 Ace Smart Transmitter Model JTR/JTE

ZIMMATAKE

Copyright, Notices and Trademarks

Printed in Japan - © Copyright 1998 by Yamatake Corporation

While this information is presented in good faith and believed to be accurate, Yamatake Corporation disclaims the implied warranties of merchantability and fitness for a particular purpose and makes no express warranties except as may be stated in its written agreement with and for its customer.

In no event is Yamatake Corporation liable to anyone for any indirect, special or consequential damages, The information and specifications in this document are subject to change without notice.

ST3000 is a trademark of Yamatake Corporation.

Safety Instructions

Preface

Correct installation/operation and periodic maintenance are essential to the safe use of your differential pressure transmitters.

Read the safety instructions provided in this manual carefully and understanding them fully before starting installation, operation, and maintenance work.

Inspection

- On delivery, make sure that the specifications are correct and check for any damage that may have occurred during transportation. This equipment was tested under a strict quality control program before shipment. If you find any problem in the quality specifications, please contact your Yamatake Corporation representative immediately, providing the model name and serial number.
- The name plate is mounted on the top of the enclosure.

Precautions

The following symbols are used in this manual to ensure the safety of users:

 **Warning:** This symbol is used to warn of hazards where failure to observe a safety instruction may result in death or serious injury.

 **Caution:** This symbol is used to warn of hazards where failure to observe a safety instruction may result in injury or physical damage.

To ensure safe operations, be sure to observe the safety instructions provided on the next page. Yamatake Corporation will assume no responsibility, or offer any guarantee with respect to any failure resulting from violation of these safety instructions.

Safety Rules

Installation

Warning

- (1) When installing the transmitter, make sure that gaskets do not protrude from the process connection parts (in adaptor flange connections to connecting pipes and flanges). Gasket protrusion may cause leaks or output errors.
- (2) Do not use the transmitter outside the rated pressure or temperature range or without observing the connection specifications. Damage or leaks may lead to serious accidents.
- (3) Apply the methods specified in the explosion-proofing guidelines to cabling work in explosion-proof areas.

Caution

- (1) Do not step on the transmitter after installation. Stepping on the transmitter may damage it or cause injuries.
- (2) The glass indicator may break if hit with a tool or other object, and cause injuries.
- (3) Ground the transmitter correctly. This is required by related regulations. Inadequate grounding may lead to output errors.
- (4) This transmitter is heavy, please be sure of your footing and wear safety shoes when installing.

Electrical wiring

Warning

- (1) To avoid electric shocks, do not perform wiring work with wet hands or without turning the power off. Wear gloves over dry hands and turn the power off before starting wiring work.

Caution

- (1) Study the specifications carefully and make sure the wiring is correct. Wiring mistakes may cause hardware damage or malfunctions.
- (2) Provide a power supply that meets the specifications. The wrong power supply may cause hardware damage.

Maintenance

Warning

- (1) When disconnecting the transmitter from the process for maintenance, ensure that the residual pressure, fluid or gas have reached safe levels. Gas generation or fluid eruption may otherwise occur.
- (2) To prevent burns or other harmful effects, check the venting or drainage direction and ensure that no personnel will be exposed to vented gas or drained fluid.
- (3) Do not open the cover during operation in an explosion-proof area. This may result in an explosion or other accident.

Caution

- (1) The transmitter was shipped under strict product control guidelines. Altering the transmitter, or modifying it in any way, may result in damage to the transmitter or to property.

CONTENTS

Precautions	A - 1
A. General Precautions	A - 1
A.1 Checking the Product	A - 1
A.2 Checking the Specifications	A - 1
A.3 Transportation	A - 1
A.4 Storage Environment	A - 2
A.5 Installation Environment	A - 2
A.6 Application of Pressure to Transmitter	A - 2
A.7 Electronic Parts	A - 3
A.8 Use of Transceiver	A - 3
A.9 Welding in Proximity of ST 3000 Ace Transmitter	A - 3
B. Precautions for Explosion-proof Transmitter	B - 1
B.1 Transmitter with Flame-proof Special Explosion-proof Construction	B - 1
B.2 Transmitter with Intrinsic-safety Construction	B - 2
1. Outline	1 - 1
2. Operating Principle	2 - 1
3. Installation	3 - 1
3.1 Installation Dimensions	3 - 1
3.2 Installation Environment	3 - 1
3.3 Installation Method	3 - 1
3.4 Mounting Direction	3 - 2
3.5 Process Installation	3 - 2
3.6 Mounting the Flange for Flow Rate Measurement	3 - 4
4. Wiring	4 - 1
4.1 Power Line	4 - 1
4.2 Ground	4 - 1
4.3 External Meter Wiring	4 - 1
4.4 Supply Voltage and Load Resistance	4 - 3
4.5 Wiring of Flame-proof Special Explosion-proof Model	4 - 4

4.6	Wiring of Intrinsic-safety Model	4 - 4
5.	Mounting a Teflon protective film on a flange	5 - 1
5.1	3B flange	5 - 1
5.2	1-1/2B, 2B flange	5 - 2
6.	Operation	6 - 1
6.1	Preparation	6 - 1
6.1.1	Checking the Wiring	6 - 1
6.1.2	Connecting the SFC (Communicator) and Ammeter Used for Checking	6 - 1
6.1.3	Checking Communications	6 - 2
6.1.4	Diagnosis of Operations	6 - 3
6.1.5	Checking Configuration Data (Parameter Values) and Output Signals	6 - 4
6.2	Adjustment before Operation	6 - 7
6.2.1	Minimum Liquid Level Position for Liquid Level Measurement (Zero Position)	6 - 7
6.2.2	Liquid Level Measurement in an Open Tank	6 - 8
6.2.3	Liquid Level Measurement in a Closed Tank	6 - 10
6.2.4	Temperature Compensation of Fill Fluid in Capillary	6 - 11
6.2.5	Flow Rate Measurement	6 - 12
6.3	Zero Adjustment for Liquid Level Measurement (Intermediate Level)	6 - 13
6.4	Starting Operation	6 - 13
6.5	Configuration (Setting)	6 - 14
6.5.1	Configuration Data Parameters (Various Settings)	6 - 14
6.5.2	Connecting the SFC (Smart Field Communicator) and External Meter	6 - 15
6.5.3	Writing Configuration Data	6 - 16
(1)	Registering the transmitter tag number	6 - 17
(2)	Saving data in the non-volatile memory (NVM) of the transmitter	6 - 18
(3)	Output format	6 - 18
(4)	Displaying and changing the indicator display format	6 - 23
(5)	Displaying and changing the engineering unit high and low limits	6 - 25
(6)	Damping time constant	6 - 27
(7)	Engineering unit	6 - 27
(8)	Range	6 - 28
(9)	Compensating for the temperature of the fill fluid in the capillary	6 - 30

(10) Saving (storing) configuration data from the transmitter to the SFC and restoring (re-entering) data saved in the SFC to the transmitter	6 - 30
6.6 Checking PROM NO and Software No.	6 - 32
6.6.1 Checking PROM NO	6 - 32
6.6.2 Checking Software No.	6 - 32
6.7 Checking Burnout Direction	6 - 32
6.8 Constant Current Source Mode	6 - 33
6.8.1 Generating Constant Current	6 - 33
6.8.2 Releasing Constant Current Source Mode	6 - 33
6.9 Scratch Pad (Memo Function to Transmitter)	6 - 34
6.9.1 Entry to Scratch Pad No.1	6 - 34
6.9.2 Releasing the Scratch Pad	6 - 36
6.9.3 Entry to Scratch Pad No.2	6 - 36
7. Calibration	7 - 1
7.1 Preparation and Setup	7 - 1
7.2 Calibrating Output Signals	7 - 2
7.2.1 Adjusting Output Signal 0%	7 - 2
7.2.2 Adjusting Output Signal 100%	7 - 3
7.3 Calibration Range	7 - 5
7.3.1 Calibrating the Low Limit (LRV)	7 - 5
7.3.2 Calibrating the High Limit (URV)	7 - 6
7.3.3 Saving Calibration Data	7 - 6
7.4 Erasing Calibration Data	7 - 7
7.4.1 Erasing Calibration Data	7 - 7
7.4.2 Erasing the “#” Mark	7 - 7
8.	
9. Maintenance and Inspection	9 - 1
9.1 Maintaining the Meter Body	9 - 1
9.2 Insulation Resistance Test and Dielectric Strength Test	9 - 1
10. Self-diagnosis	10 - 1
10.1 Contents of Diagnosis	10 - 1
10.1.1 Non-critical Errors	10 - 1

10.1.2	Critical Errors	10 - 1
10.1.3	Communication Errors	10 - 2
10.1.4	Operational Errors	10 - 2
10.2	Method of Diagnosis	10 - 3
10.3	Display Messages	10 - 3
10.4	Messages and Required Actions	10 - 4
11.	Troubleshooting	11 - 1
12.	External Zero Point Adjustment (Optional)	12 - 1
12.1	External Zero Point Adjustment	12 - 1
12.2	Influence due to Magnetic Fields	12 - 2
13.	Indicator (Optional)	13 - 1
13.1	Identification of indicator parts	13 - 1
13.2	Digital display	13 - 1
13.3	Analog bar graph display	13 - 2
13.4	Linear/square root extraction display	13 - 2
13.5	External zero point adjustment display	13 - 3
13.6	Self-diagnosis display on indicator	13 - 3
13.7	Self-diagnosis by indicator (optional)	13 - 4
13.8	Engineering Unit Label	13 - 5
14.	Direct mounting	14 - 1
14.1	Overview	14 - 1
14.2	Characteristics	14 - 1
14.3	Specifications	14 - 2
14.4	Direct Mounting Transmitters	14 - 2
14.5	Installation procedure	14 - 2
14.5.1	Installation dimensions	14 - 2
14.5.2	Installation location	14 - 3
14.5.3	Installation procedure	14 - 3
Appendix A.	Specifications, Model No., External dimensions	Appendix A.

Precautions

A. General Precautions

A.1 Checking the Product

When you accept the ST 3000 Ace Smart Transmitter, check its appearance to make sure that it is not damaged.

The accessories shown in Figure A.1 should be attached (Options). Make sure that all the accessories have been delivered to you.

To make an inquiry, contact your supplier or our service network. The accessories are listed below.

- (1) One L-wrench (M3)
- (2) 1 mounting bracket, 1 U-bolt, 4 bolts and 2 nuts

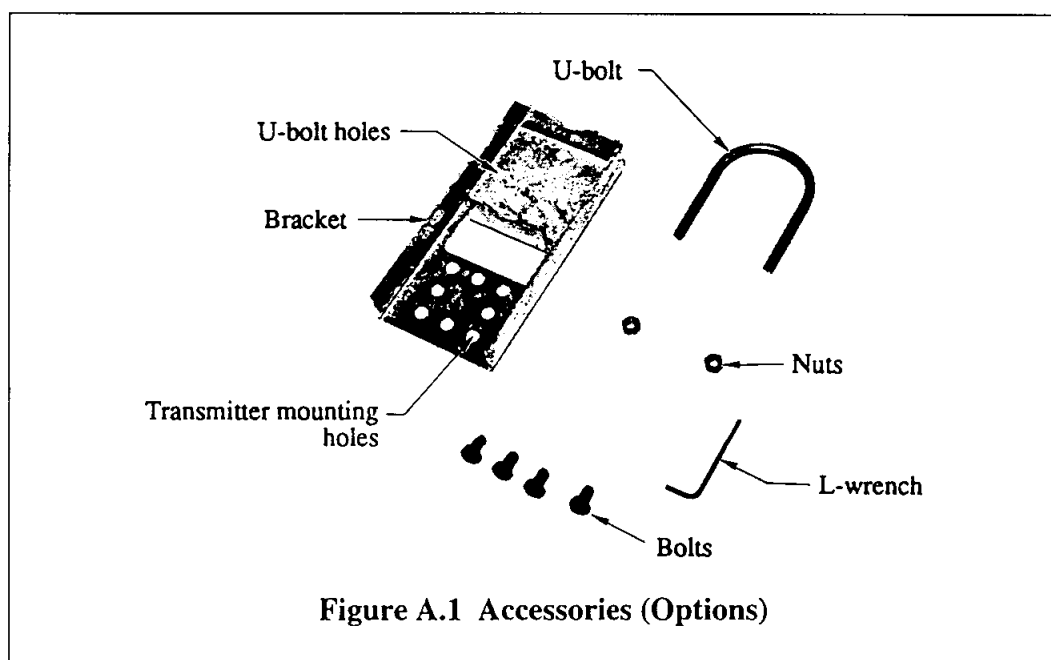

Note) A Smart Transmitter with semi-standard or special specifications may have different accessories.

A.2 Checking the Specifications

The specifications are marked on the name plate on the outside of the transmitter case. Make sure that the specifications match your order by referring to the specifications and the model number table in Appendix A.

In making an inquiry, identify the model No. and the product No.

A.3 Transportation

We recommend to transport the transmitter to the installation site in the packaged state in order to prevent damages from occurring during transportation.

A.4 Storage Environment

- (1) Storage location
During storage, protect the transmitter from rain water as well as from heavy vibration and shock. Store it at normal temperature and humidity (about 25°C, 65%RH) as much as possible.
- (2) Store the transmitter without unpacking it if possible.
- (3) If a used transmitter must be stored for some period, wash it thoroughly after making sure that no fluid remains in the pressure receiving section. (For detailed information, refer to 9.2.2 Washing Meter Body.)

A.5 Installation Environment

In order to maintain the original performance and reliability for a long period, install the transmitter in the following environment.

- (1) Ambient temperature
 - (a) The temperature gradient and temperature changes in installation environment should be as small as possible.
 - (b) If a transmitter is exposed to heat radiated from the plant side, lower its ambient temperature as much as possible by insulating it or by selecting a well-ventilated location for installation.
 - (c) If a process fluid can freeze, prevent freezing by means of heat insulation.
- (2) Atmosphere
Avoid corrosive atmospheres as far as possible.
For flame-proof special explosion-proof and intrinsic-safety constructions, refer to Section B.
- (3) Shock and vibration
Install the transmitter where shocks and vibrations will be as small as possible.
- (4) Installation of explosion-proof type transmitter
Refer to "B. Instructions for Explosion-proof Transmitter".

A.6 Application of Pressure to Transmitter

In applying pressure to this transmitter, observe the following rules.

- (1) The locking bolts of the adapter flange are loose when shipped. Tighten them to the specified torque.
- (2) Do not apply a pressure that exceeds the specified level. (Refer to 1.2.2 Specifications.)
- (3) Do not tighten or loosen bolts while pressure is being applied to the transmitter.
- (4) When a transmitter is used for measuring a poisonous substance, handle it carefully even after the pressure is released.

A.7 Electronic Parts

- (1) This transmitter has several CMOS electronic components. Since static electricity can easily cause the functional destruction of a CMOS component, never directly touch them or cause a circuit with your hands.
- (2) If components must be touched, equalize the potential of the components before doing so.
- (3) When the printed wiring board (PWB) is removed, protect it in a non-conductive bag.

A.8 Using a Transceiver

- (1) When a transceiver is used very near a transmitter, its transmission frequency (in the form of high frequency noise) may cause radio interference in some cases.
- (2) When using a transceiver, determine the distance that will be necessary for avoiding any influence on signals in advance, and ensure that the distance between the transceiver and the transmitter is larger than that distance.
- (3) When using a transceiver, be sure to close the cover of the transmitter.

A.9 Welding in Proximity of ST 3000 Ace Transmitter

- (1) When welding is to be carried out near the transmitter, the welding current may affect the operation of the transmitter depending on the grounding method.
- (2) Directly ground the welding equipment and power transformer. Do not ground to the stanchion pipe of the transmitter.
- (3) Turn off the power supply to the transmitter.

B. Precautions for Explosion-proof Transmitter

An explosion-proof transmitter has passed the required inspections at a public organization, in compliance with the Labor Safety and Hygiene Law. Use of an explosion-proof transmitter in a hazardous environment is permitted.

The transmitter has a name plate which displays the conformance mark and the information needed for preventing explosions. Check this information and use the transmitter correctly.

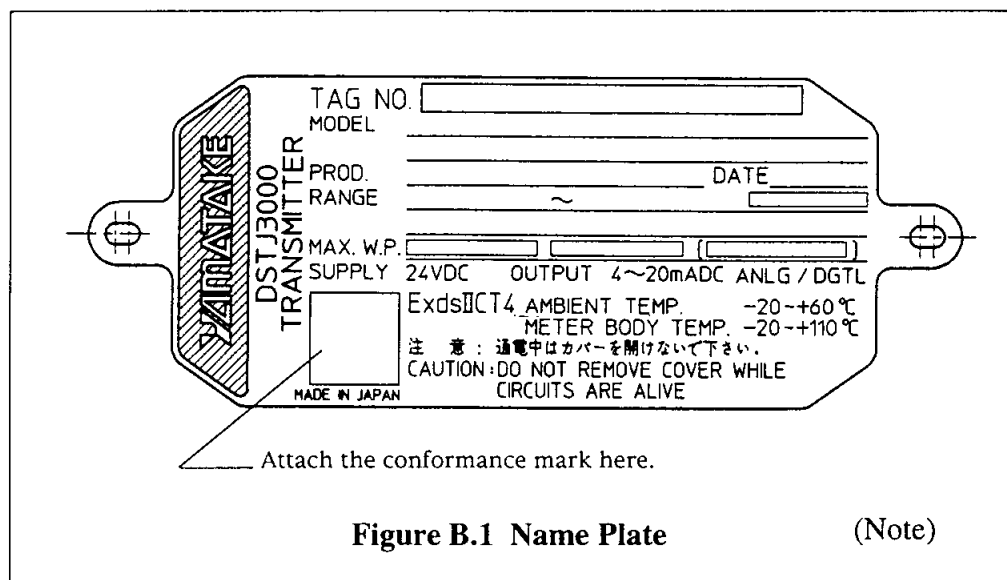

Note: Ambient temperature range may be narrower than that indicated on the nameplate above depending on models.

B.1 Transmitter with Flame-proof Special Explosion-proof Construction

Precautions on Handling Transmitter:

(1) Installation Environment

The explosion class and the gas ignition temperature for this transmitter are “IICT4” (IIC: All gas vapor, T4: Gas vapor with ignition temperature of 135°C). It can be installed in “Class 1” and “Class 2” hazardous environments. It cannot be installed in a class 0 environment.

Make sure that the ambient temperature is within the range shown on the name plate. Here, AMBIENT TEMP. and METERBODY TEMP. mean the temperature around the transmitter and the temperature at the meter body (in contact with the fluid), respectively. If the ambient temperature exceeds these ranges, explosion-proof performance cannot be guaranteed. In such a case, lower the ambient temperature by following the instructions in “A.5 (1) Ambient temperature”.

(2) Wiring method

For the external wiring, use the flame-proof packing type cable adaptor provided as an accessory.

Caution

The flame-proof packing type cable adaptor which is provided as an accessory for the explosion-proof transmitter is inspected as a part of the case. Therefore, its explosion-proof performance cannot be guaranteed if combined with any other equipment.

(3) Maintenance

- (a) In a hazardous environment, do not open the transmitter case cover or the meter case cover while the transmitter is running.
- (b) The flame-proof explosion-proof performance is maintained because of the distance between clearances and the mechanical strength of the container. Therefore, avoid any case or cover corrosion, deformation or damage, and screw or joint damage that may lower the flame-proof explosion-proof performance.

If any damage arises, contact us.

Note) For detailed information about (1), (2) and (3), refer to “New Explosion-proof Guideline for Electric Plant Facilities (Gas Explosion Proof 1979)” published by the Industrial Safety Institute of the Ministry of Labor.

B.2 Transmitter with Intrinsic-safety Construction

Precautions on Handling Transmitter

(1) Installation Environment

The explosion class and the ignition temperature of gas for this transmitter are “3aG4” (3a: Gas of explosion class 2, including hydrogen, G4: Gas vapor with ignition temperature of 135°C). It can be installed in “Class 0”, “Class 1” and “Class 2” hazardous environments.

Make sure that the ambient temperature is within the range shown on the name plate. Here, AMBIENT TEMP. and METERBODY TEMP. mean the temperature around the transmitter and the temperature at the meter body (in contact with the fluid), respectively.

(2) Wiring method

Meet the conditions shown in the system configuration drawing (Figure B.2) and avoid electrical and magnetic influence (mixing, induction etc.) from the lines of other electric circuits. Protect the cables from external damage.

(3) Maintenance

If the parts or internal wiring are changed, intrinsic-safety performance cannot be guaranteed. If repair is necessary, replace the entire printed wiring board.

Note) For detailed information about (1), (2) and (3), refer to “Explosion-proof Guideline for Electric Plant Facilities (Gas Explosion-proof 1979)” published by the Industrial Safety Institute of the Ministry of Labor.

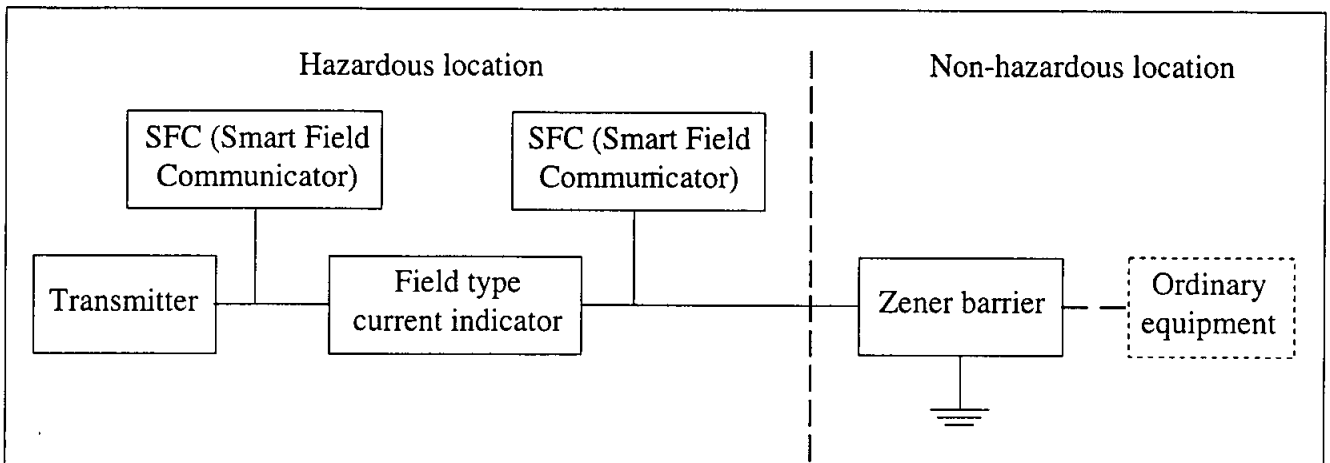

Figure B.2 System Configuration

- (a) Install a Zener barrier (8907/51 - 24/45) in a non-hazardous location and perform independent class 1 ground work.
- (b) The inductance and the capacitance of the external wiring of an intrinsic-safety circuit must not exceed 0.45 mH and 21 nF, respectively.
- (c) The conditions for ordinary equipment connected to a Zener barrier are 500 VAC and 35 A or lower.
- (d) Use the field type current indicator and SFC which have passed inspection in combination with the intrinsic-safety transmitter.

1. Outline

1.1 Outline

The ST3000 Ace Smart Transmitter has an integrated micro-processor and transmits an analog signal of 4 to 20 mA DC in proportion to the measured differential pressure.

Parameters (range, damping time constant, constant-current output etc.) can be set and changed remotely from the instrument room via the SFC (portable setting display). An external zero adjustment function is available as an option. This function enables zero adjustment by the transmitter.

2. Operating Principle

In the pressure receiving unit, the differential pressure (process pressure) of the process fluid is transmitted to the sensor unit via a filler fluid.

The differential pressure (process pressure) sensor of the sensor unit is strained according to the transmitted differential pressure (process pressure) and its resistance value changes. This resistance value is detected by the Wheatstone bridge circuit and sent to the transmitting section after A/D conversion. At the same time, the ambient temperature and the static pressure are detected by the two types of auxiliary sensors (temperature sensor and static pressure sensor) on the sensor chip and sent to the transmitting unit after digitalization.

The signals that are sent to the transmitting unit are processed by the microprocessor.

For the analog output signal, the differential pressure (process pressure) of the process fluid is outputted after being converted to an analog signal of 4 to 20 mA DC corresponding to the preset range.

The differential pressure (process pressure), temperature and static pressure characteristics data for each transmitter are collected during the manufacturing process and loaded into the PROM of each transmitter via a production line computer.

The micro processor processes information in the memory and outputs the results.

A wide range of I/O characteristics data for the semiconductor sensors are also loaded into the PROM.

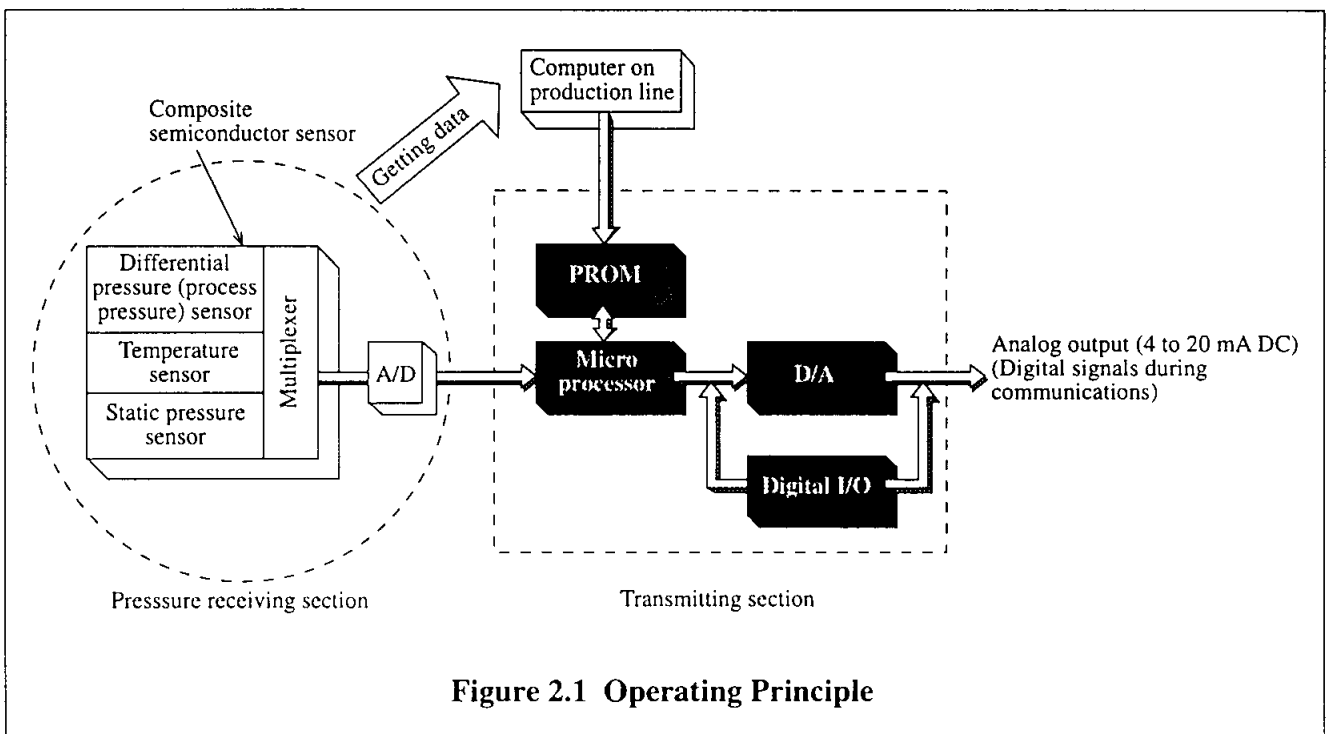

Figure 2.1 Operating Principle

3. Installation

3.1 Installation Dimensions

Refer to the external dimensions drawing in Appendix A.

3.2 Installation Environment

Refer to Precautions “A.5 Installation Environment.”

3.3 Installation Method

The transmitter can be installed by the following two methods.

- Pipe stanchion mounting
- Line mounting

In both cases, the bracket on which the transmitter is mounted is fixed to a vertical 50mm pipe or a horizontal 50mm pipe using the U-bolt. Make sure that the pipe is locked firmly to the foundation. It should not be unsteady.

For the line mounting method, the parts that are used for mounting a 50mm pipe to a line pipe are needed. The rear side of the pressure receiving section has 4 bolt holes. Mount this section on the bracket.

Note) In mounting a transmitter on a 50mm pipe, note that the assembly sequence of “transmitter - bracket - 50mm pipe” depends on the mounting direction.

< Attention >

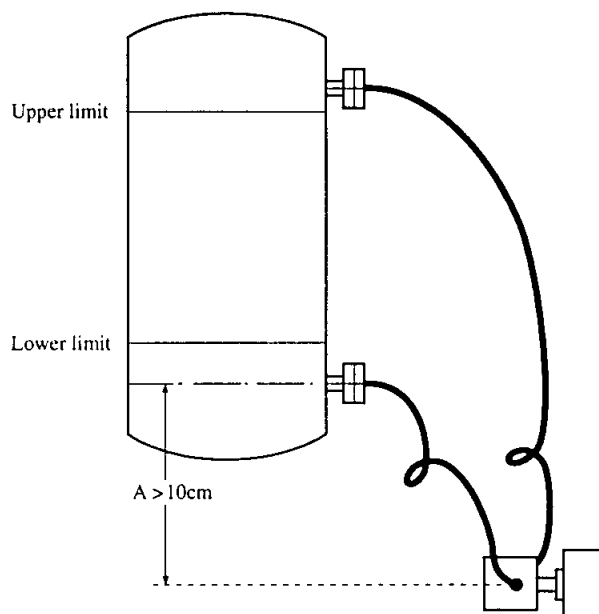

Note:

- 1) For application to measuring liquid with hydrogen, consult us.
- 2) Mount the transmitter at 10cm lower than the lower tank nozzle.

**Figure 3 Location of Mounting Transmitter
(example of tank level measurement)**

3.4 Mounting Direction

No special restriction is provided on the mounting direction.

However, the best method is to keep the pressure receiving diaphragm vertical.

After mounting the transmitter, adjust the zero point.

3.5 Process Installation

- (1) Mount the flange on the process side flange using bolts and a gasket. Lock the bolts evenly and firmly in order to prevent leakage.

Minimize temperature changes in the capillary tube. Fix it to an appropriate support to prevent movement.

* Provide a flange gasket on the process side. If using a semi-metal or rubber gasket, select a gasket with a shape such that it will not touch the detector diaphragm.

- (2) A flange used for measuring the liquid level in an open container should be fixed firmly to a place which has minimal temperature changes and no vibration. Protect the seal diaphragm to prevent damage. Make sure that no drain, or dust accumulates.

Remarks:

1. Do not twist the capillary tube.
2. In unwinding the capillary tube, hold the flange part and unwind the large ring of the tube.
3. Make sure that the capillary outlet extends downward from the horizontal position (so that no rain water will enter the protection pipe of the capillary outlet port.)
4. Do not apply a twisting force to the flange base by turning the capillary tube.
5. It is recommended that the capillary tube be fixed at a mid-point position in order to prevent mechanical vibration.

- (3) Gasket selection for flange (3B flush mount)

Select the gasket for the flange, considering the following factors:

Since the diaphragm diameter is 95 mm, a commercially available 3B gasket will touch the diaphragm and may cause errors.

Select an appropriate material based on factors such as fluid, operating pressure and temperature. The inner diameter is also an important factor. The inner diameter should not come into contact with the diaphragm even if the gasket becomes misaligned or deformed.

Remarks:

- ① Select a gasket with an appropriate inner diameter (the diaphragm diameter is 95 mm.).
A commercially available 3B gasket is not appropriate because its inner diameter is too small (80 - 90 mm).
- ② Gasket collapse or deformation should not cause contact with the diaphragm.
 - A gasket made of a soft material can be deformed by tightening.
 - A gasket in transmitters mounted in the vertical position sometimes shift downward.
 - Align the gasket accurately.
- ③ A gasket with a Teflon protective film requires the following precautions in addition to ① and ②.
 - Excessive gasket tightening may cause damage to the protective film.
 - Mount the protective film according to the "FEP Protective Film Mounting Procedure."
 - If the zero point changes greatly after installing the pressure receiving unit, excess grease or gasket misalignment may be the cause.

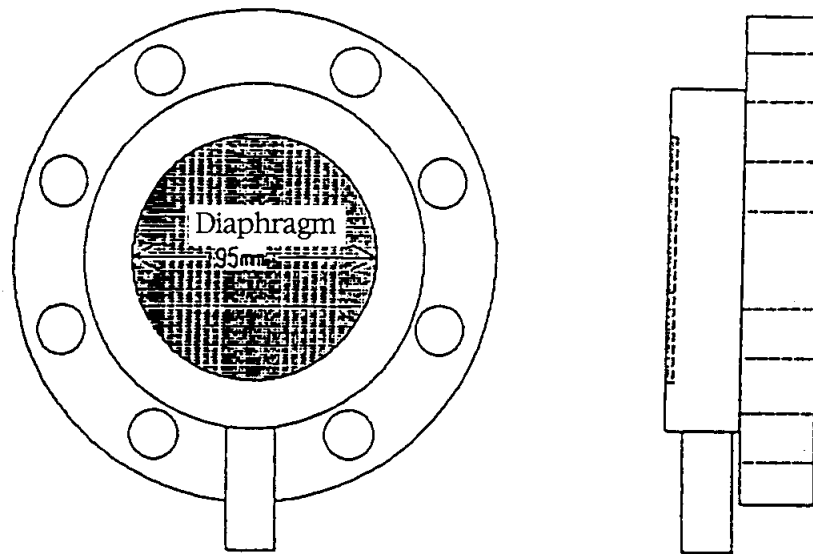

Figure 3.1 External View of Pressure Receiving Unit

Selection example

Fluid : Sea water
 Temperature : Normal temperature
 Pressure : Max. 300kPa {3 kg/cm²}
 Gasket with Teflon protective film
 Flange : 3BJIS10k

Material : Non-flammable material
 (Non-asbestos)
 External dimension : 134 mm
 Inner diameter 98 mm ⁺²/₀
 Thickness : 2 mm

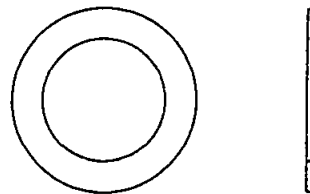

Figure 3.2 External View of Gasket

3.6 Mounting the Flanges for Flow Rate Measurement

When the transmitter is used for flow rate measurement, the differential pressure outlet taps should be mounted using the pipe tap method. If the inner diameter of a pipe is D , mount the high pressure side tap $2.5D$ from the upstream side orifice face and mount the low pressure side tap $8D$ from the downstream side orifice.

Connect the differential pressure outlet tap using a 3" flange. Mount the flange of the transmitter directly.

Remarks:

1. Do not twist the capillary tube.
2. In unwinding the capillary tube, hold the flange part and unwind the large ring of the tube.
3. Do not apply a twisting force to the flange base by turning the capillary tube.

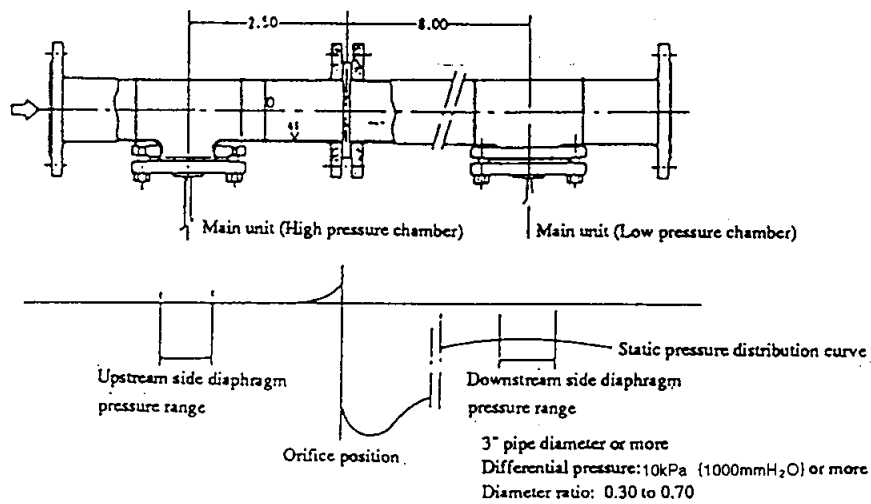

Figure 3.3 Orifice Plate Assembly

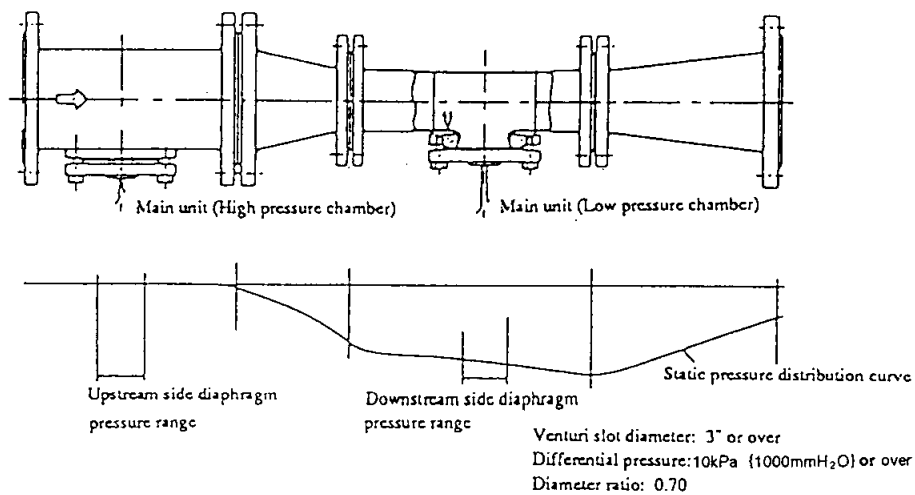

Figure 3.4 Venturi Tube Assembly

4. Wiring

4.1 Power Line

Since the two-wire system is adopted for the Model JTD transmitter, one line is used both as a power line and a signal line as shown in Figure 4.1.

Cables are led to the terminal unit through the side conduit hole (G1/2 internal thread).

Close the conduit connection part with sealing agent or a sealing plug so that no water drops can enter into the transmitter case.

Make sure that the cables start below the connection ports.

(An elbow to be used for changing the electrical*¹ wiring direction is available. Use it if necessary.)

* 1 Select Optional Specifications - G1, G2 or G3.

4.2 Ground

Two ground terminals are provided; one on the terminal unit and the other on the outside. Either one may be used. Connect the ground terminal to a Class 3 ground (ground resistance of 100 Ω or less) or higher quality ground.

4.3 External Meter Wiring

When an external meter is used, dismount the jumper board and connect the lines as shown in Figures 4.1, just like when a transmitter with a meter is used. Dismount the conduit lid after loosening its stopper using a L-wrench. When an external meter is not connected, do not dismount the jumper board.

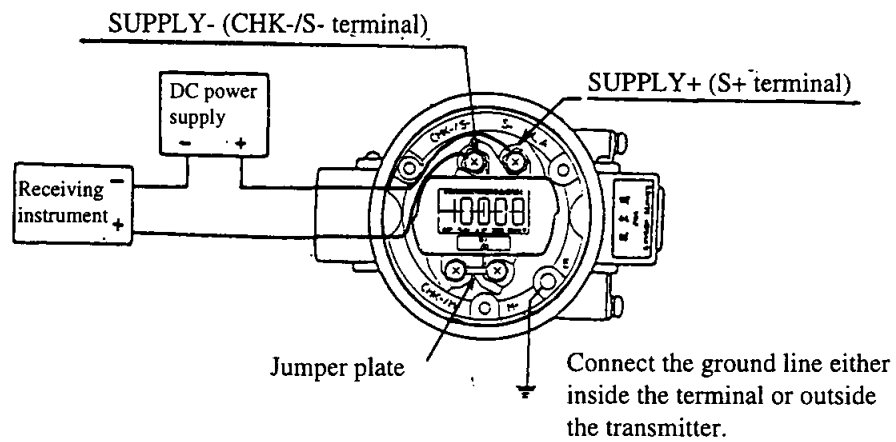

Receiving instrument connection

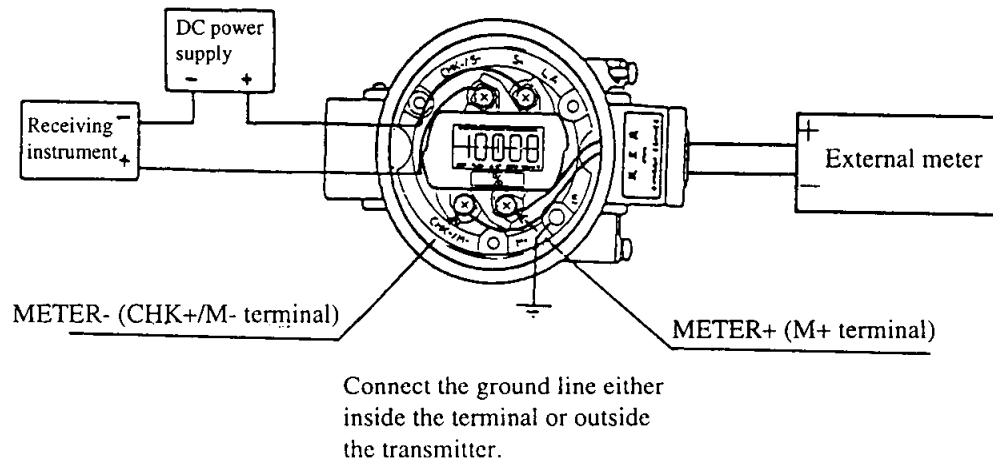

External meter connection

Figure 4.1 Wiring

4.4 Supply Voltage and Load Resistance

Make sure that the load resistance connected to the loop is within the range shown in Figure 4.2.

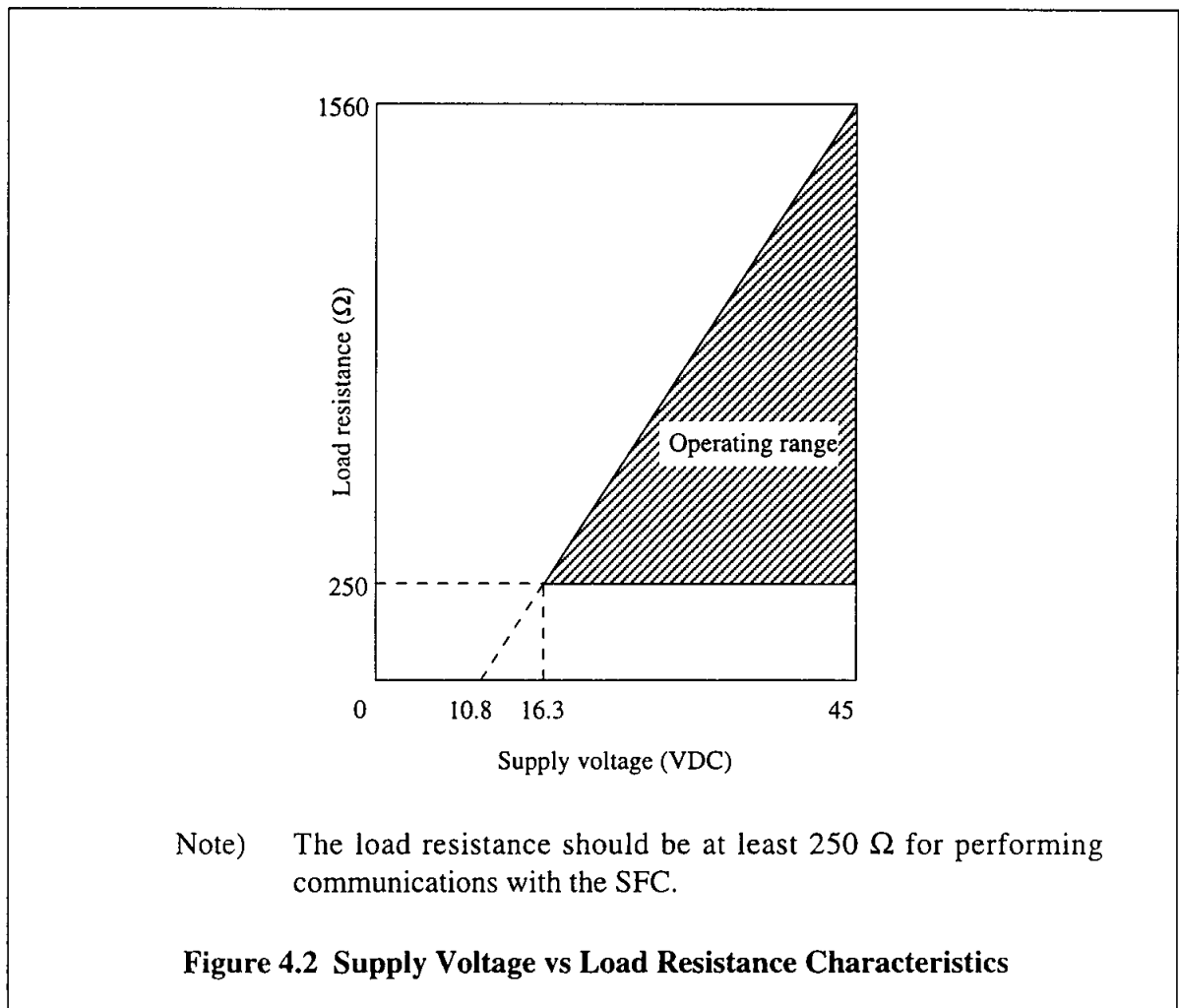

4.5 Wiring of Flame-proof Special Explosion-proof Model

A transmitter with the flame-proof special explosion-proof construction has a transmitter case cover and a meter case cover characterized by having a locking structure. Tighten the covers after wiring and lock them firmly. (Use L-wrench M3 for flame-proof special explosion-proof construction locking.)

(A transmitter with an indicator requires locking of two parts: the transmitter and the meter. See Figure 4.3.)

The wiring method is explained in “B.1.(2), Wiring Method”.

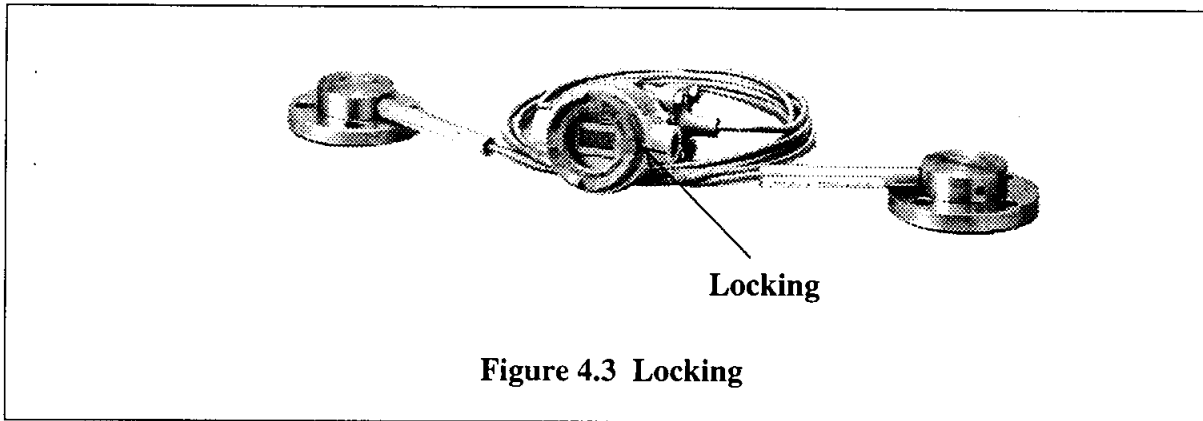

4.6 Wiring of Intrinsic-safety Model

The wiring method is explained in “B.2.(2), Wiring Method”.

For the Zener barrier (8907/51-24/45), refer to manual OM2-3260-8900.

5. Mounting a FEP protective diaphragm on a flange

5.1 3B flange

Perform the following work immediately before mounting to the pressure receiving unit flange.

1. Hold the transmitter with the pressure receiving unit diaphragm flange facing upward.
2. Apply about 15 g of Diaflow Grease to the diaphragm surface and spread a thin layer of it over the entire surface with your fingers.

(The average grease thickness on the diaphragm should be about 2 mm.) (refer to Figure 5.1.)

3. Fit a FEP protective diaphragm into the raised face of the diaphragm (refer to Figure 5.2.)
4. Spread the grease outward from the central part of the diaphragm toward the outside. Spread slowly, ensuring that all air is excluded between the diaphragm and the Teflon protective diaphragm. Squeeze the grease out until almost none remains on the raised face.

The average grease thickness on the diaphragm will be about 0.5 mm after squeezing out 5 - 7 g of grease.

Do not apply excessive force, as this may deform the diaphragm. (refer to Figure 5.3.)

5. Place a non-flammable gasket (non-asbestos) on the pressure receiving unit flange and mount on the process flange. Tighten bolts and nuts to a tightening torque of about 200 kgf-cm.
6. If zero point fluctuations may adversely effect operations, record the input data before and after flange tightening using the SFC, and keep fluctuations between $\pm 0.1 \text{ kPa}$ ($\pm 10 \text{ mmH}_2\text{O}$).

Since large fluctuations may cause zero point shifting, repeat the above work.

(Note) Considerable skill is required to apply grease without causing large zero point fluctuations. If you are not successful, ask your Yamatake Corporation representative or service staff for help.

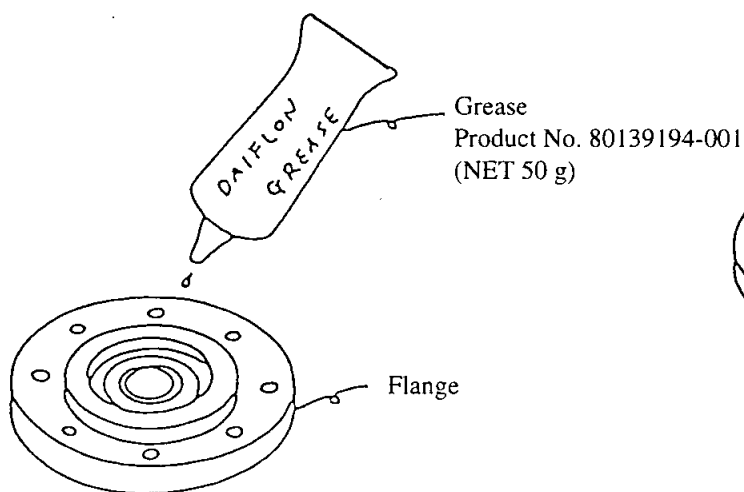

Figure 5.1

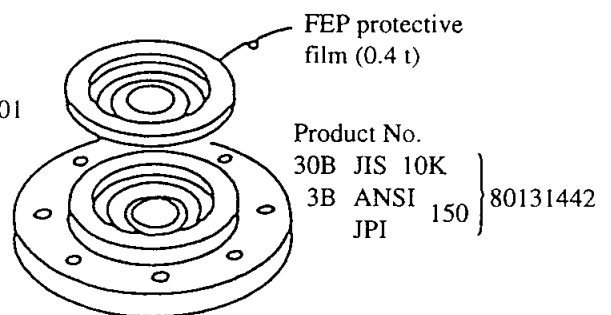

Figure 5.2

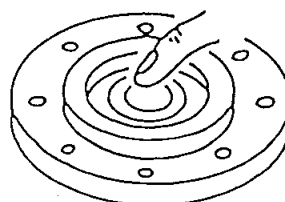

Figure 5.3

5.2 1 1/2B, 2B flange

Perform the following work immediately before mounting the transmitter pressure receiving unit flange on the process flange.

1. Hold the transmitter with the pressure receiving unit flange diaphragm facing upward.
2. Apply about 10 g (about 1/4 of one tube) of Diaflow Grease (No. DG-203, Daikin Kogyo Co., Ltd.) to the diaphragm surface and the gasket contact surface, spread it with your fingers until the thickness on the gasket surface is about 0.5 mm (refer to Figure 5.4.).

Note 1) Do not apply excessive force as this may deform the diaphragm.

Note 2) Make sure that no air bubbles remain in the grease.

3. Fit the FEP protective diaphragm onto the flange diaphragm surface. Lift one side and fit gently from the opposite direction, being careful to exclude all air. (refer to Figure 5.5.)

Note 1) Keep the FEP protective diaphragm in tight contact with the diaphragm.

Note 2) Ensure that the wavy part of the FEP protective diaphragm does not form a convex shape.

4. After performing the above work, exclude all air from between the diaphragm and the FEP protective diaphragm. Air trapped under the film can cause large measurement errors. Squeeze out remaining air with your fingers from the central part of the diaphragm toward the perimeter (refer to Figure 5.6.).

5. Lay a FEP-covered gasket or an non-flammable gasket on the flange of the pressure receiving unit and mount it on the process flange.

The recommended bolt and nut tightening torque (reference values) is shown in Table 1.

Note 1) Tighten all bolts with uniform torque.

Table 5.1

Flange rating	Tightening torque (N•m{kgf-cm})
JIS10K - 50A	29.4 {300}
JIS10K - 40A	19.6 {200}
150 # - 2B	27.4 {280}
150 # - 1.5B	19.6 {200}

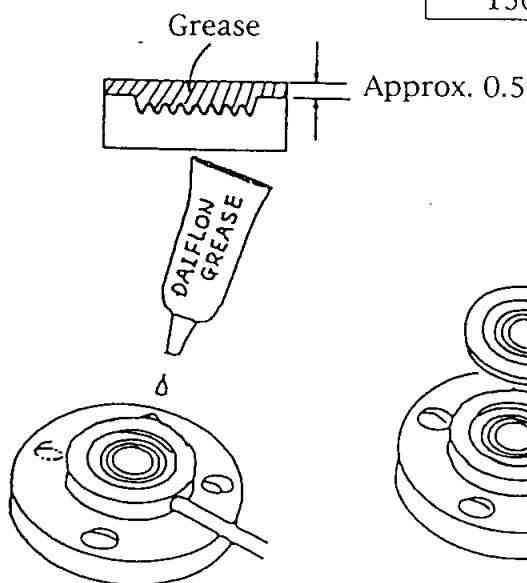

Figure 5.4

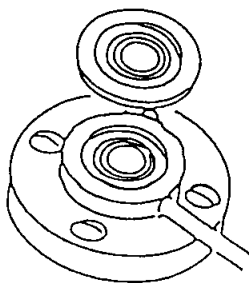

Figure 5.5

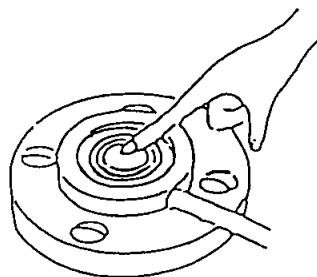

Figure 5.6

6. Operation

The S-SFC operating instructions in this section are applicable to S-SFC software version 7.1 and later versions.

Refer to Smart Communicator Operation Manual CM2-SFC100-2001.

During communications, keep the control loop connected to the transmitter in the manual mode.

6.1 Preparation

6.1.1 Checking the Wiring

Check to see if the transmitter has been wired correctly.

6.1.2 Connecting the SFC (Communicator) and Ammeter Used for Checking

Connect the SFC and a high accuracy ammeter to the terminal board as shown in Figure 6.1. The SFC can be connected to the panel terminal in an instrument room or in the field, according to the purpose.

(Note) It is possible to insert a precision resistor into the line and connect a digital voltmeter instead of an ammeter. In this case, obtain the voltage for that resistance value at 4 to 20 mA. Since a digital signal is superposed on the 4 to 20 mA DC line during communications, keep the process control loop in the manual state in order to prevent their influence.

- (1) Dismount the case cover of the transmitter.
- (2) Connect the red and black lead wires of the SFC to the + tab and the - tab of the SUPPLY terminal, respectively. Make sure that the polarity is correct.
- (3) Connect the lead wires of the meter to the test terminals of the terminal block. Make sure that the polarity is correct.

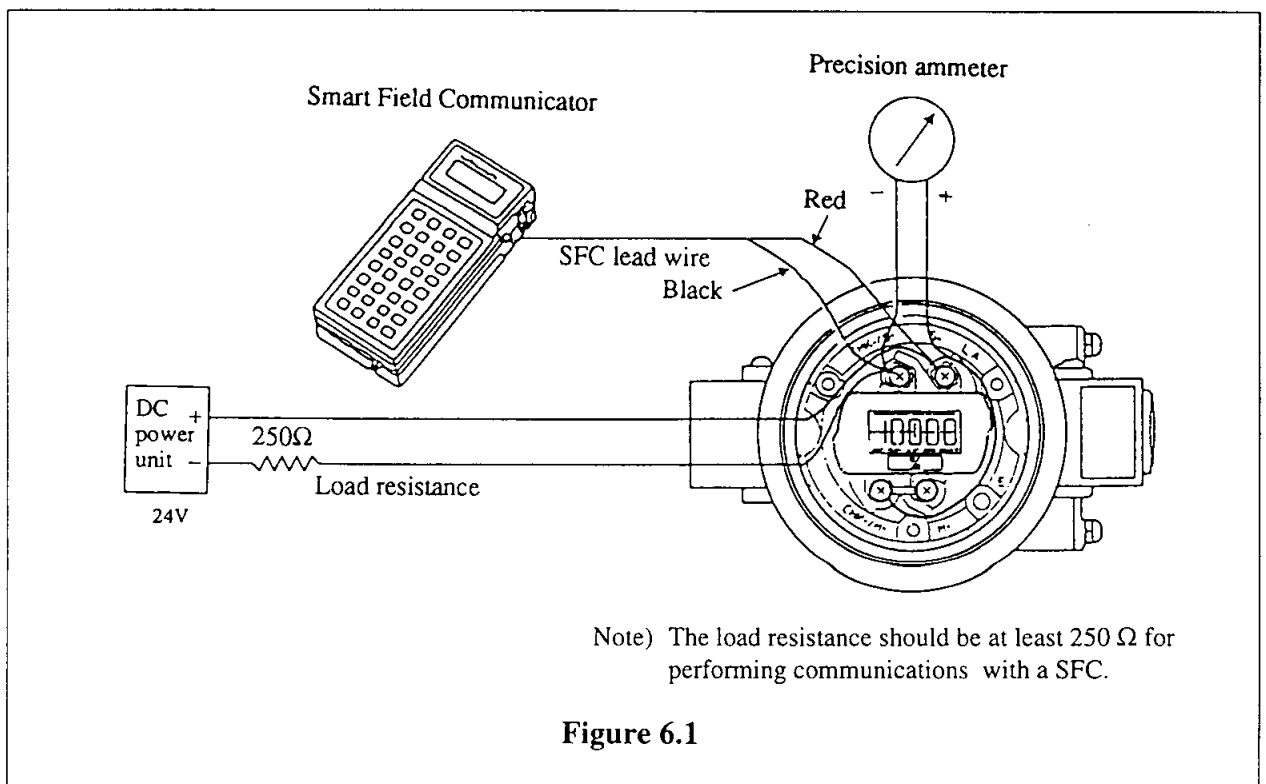

Figure 6.1

6.1.3 Checking Communications

After installing the transmitter, check communications with the SFC and the parameters that must be set.

(Note) After connecting the SFC, be sure to check the tag number of the transmitter by pressing the ID key first. None of the functions will operate until the tag number is checked by pressing this key.

- Turn on the power switch of the SFC. The display will ask whether the process control loop is in the manual mode. If it is not in the manual mode, change its mode to the manual mode.

L	O	O	P	I	N	M	A	N	U	A	L	?		
P	R	E	S	S	I	D								

- Press the "ID" key, and the output format, the transmitter type (DP: Differential pressure), and its tag number will be displayed. Check them.

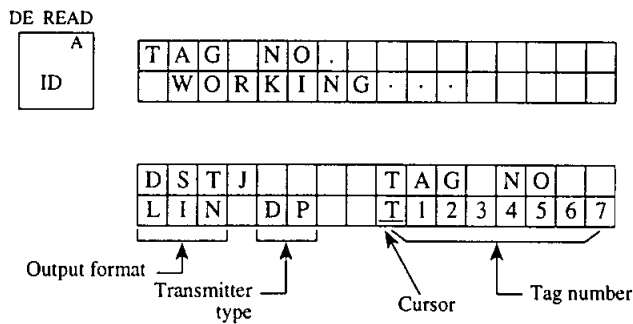

The tag number is "xxxxxxxx" at the time of plant shipment.

- If the display is not as shown in step (2), some kind of communication problem exists. Refer to the following diagnosis procedure.

[Example]

D	S	T	J			T	1	2	3	4	5	6	7	
N	O	X	M	T	R	R	E	S	P	O	N	S	E	

6.1.4 Diagnosis of Operations

Check the state of the transmitter.

(1) Press the "STAT" key and read the diagnosis information.

F/S	DIR
U	
STAT	

D	S	T	J				T	1	2	3	4	5	6	7
	W	O	R	K	I	N	G	.	.	.				

D	S	T	J				T	1	2	3	4	5	6	7
S	T	A	T	U	S		C	H	E	C	=	O	K	

or

D	S	T	J				T	1	2	3	4	5	6	7	
							(Diagnosis message)								

then

D	S	T	J				T	1	2	3	4	5	6	7
S	T	A	T	U	S		R	E	C	E	I	V	E	D

Generally, pay attention to the following items.

- ① Are the transmitter and the SFC connected correctly?
- ② Is the loop functioning correctly?
- ③ Does the resistance value between the SFC and the power unit satisfy Figure 4.4?

6.1.5 Checking Configuration Data (Parameter Values) and Output Signals

Check the high limit of the adjustable range, the configuration data, and the output signals to make sure that the transmitter operates normally and reliably.

(1) Checking the high limit of the adjustable range

Check the high limit of the adjustable range in order to make sure that the set range of the transmitter is adequate.

① Display the high limit of the adjustable range of the transmitter.

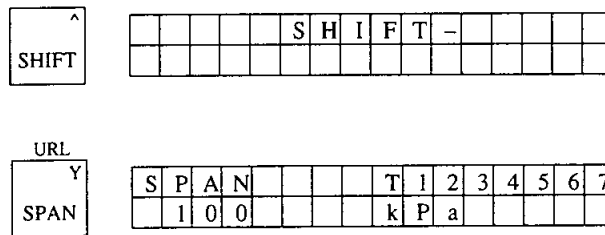

② Check to make sure that the high limit of the set range is not above the high limit of the adjustable range. If it is above the high limit of the adjustable range, replace the transmitter with that for other specifications (higher range limit).

(2) Checking the configuration data

Display the configuration data of the transmitter on the SFC.

① Transmitter output format, transmitter type, tag number

(a) Analog transmission

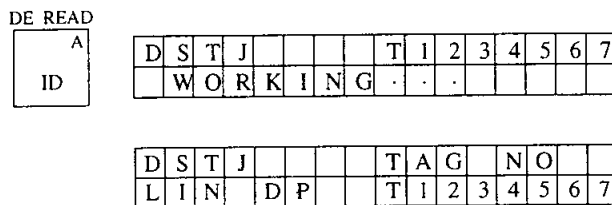

② Damping time constant

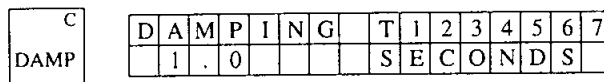

③ Low limit of range

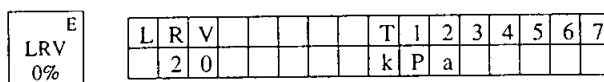

④ High limit of range

URV2																
F	URV	U	R	V					T	1	2	3	4	5	6	7
100%		I	0	0					k	P	a					

(3) Checking output signals

Set the transmitter to the constant current source mode by the following procedure and check to see if it outputs 0% and 100% signals.

(Note) At the same time, check to see whether the transmitter output is received normally by the receiving equipment.

① Set the transmitter to the constant current source mode and transmit a 0% output signal.

INPUT																
J	OUT-PUT	O	U	T	P	U	T		T	1	2	3	4	5	6	7
		W	O	R	K	I	N	G	.	.	.					

O	U	T	P	U	T		T	1	2	3	4	5	6	7
0	.	0	0				%							

Measured value \uparrow

Z																
0		O	U	T	P	U	T		T	1	2	3	4	5	6	7
		0					%									

NON-VOL																
ENTER (Yes)		O	U	T	P	U	T		T	1	2	3	4	5	6	7
		0	.	0	0				%							#

② Read the meter to check to see if it indicates a 0% signal (4 mA).

(Note) A "#" mark indicates that the transmitter is in the constant current source mode.

③ Set the transmitter to the constant current source mode and transmit a 100% output signal.

INPUT																
J	OUT-PUT	O	U	T	P	U	T		T	1	2	3	4	5	6	7
		W	O	R	K	I	N	G	.	.	.					

O	U	T	P	U	T		T	1	2	3	4	5	6	7
0	.	0	0				%							

Measured value \uparrow

V																
1		O	U	T	P	U	T		T	1	2	3	4	5	6	7
		1					%									

ACTPR #																
Z		O	U	T	P	U	T		T	1	2	3	4	5	6	7
0		1	0	_			%									

ACTPR																
Z		O	U	T	P	U	T		T	1	2	3	4	5	6	7
0		1	0	0	_		%									

NON-VOL																
ENTER (Yes)		O	U	T	P	U	T		T	1	2	3	4	5	6	7
		1	0	0	.	0	0		%							#

- ④ Read the meter to check to see if it indicates a 100% signal (20 mA).
- ⑤ If the meter indication is correct, release the constant current source mode by the following procedure. If any error is found, refer to 11. "Troubleshooting" or 7.2 "Calibrating Output Signals".

INPUT														
J OUT- PUT	O	U	T	P	U	T	T	1	2	3	4	5	6	7
	W	O	R	K	I	N	G	.	.	.				

O	U	T	P	U	T	T	1	2	3	4	5	6	7
1	0	0	.	0	0	%							#

CLR														
J (No)	O	U	T	P	U	T	T	1	2	3	4	5	6	7
	W	O	R	K	I	N	G	.	.	.				

D	S	T	J			T	1	2	3	4	5	6	7
R	E	A	D	Y	.	.	.						

(Note) The "#" mark will disappear, indicating that the constant current source mode has been released.

6.2 Adjustment before Operation

Make adjustments under the actual process conditions.

The specific gravity of the fill fluid is 0.935 (at 25°C). The specific gravity varies with change in temperature at the rate of 0.0008/°C. Hereafter, use the capillary tube temperature to calculate the specific gravity.

6.2.1 Minimum Liquid Level Position for Liquid Level Measurement (Zero Position)

The zero position of the measured liquid will be the center of the seal diaphragm on the face of the process connection flange of the transmitter. (Refer to Figure 6.2.) Therefore, the measurement range H will be from the center of the transmitter flange to the specified range height.

Check the zero point of the transmitter by lowering the measured liquid level below the lower edge of the diaphragm of the process flange face (high pressure side). The low pressure side diaphragm and the high pressure diaphragm must be mounted at the same height and that must be no liquid head pressure being applied. In other words, check the zero point by equalizing the pressures applied to the low and high pressure side diaphragms.

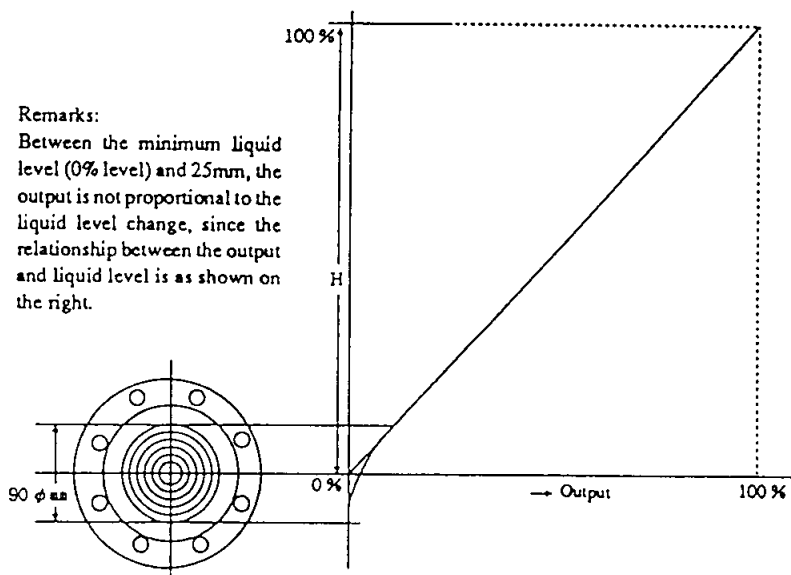

Figure 6.2 Minimum Liquid Level Characteristics

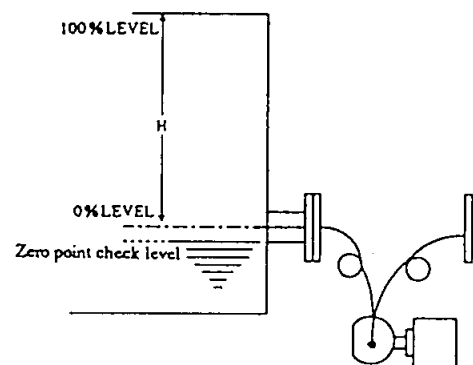

Figure 6.3 Determination of Zero Position

6.2.2 Liquid Level Measurement in an Open Tank

If the high pressure side diaphragm and the low pressure side diaphragm are mounted at the same position for the liquid level measurement of an open tank, the sum of the head pressure of measured liquid and the atmospheric pressure is applied directly to the high pressure side diaphragm. Atmospheric pressure is applied to the low pressure side diaphragm, because it is open to the air. This means that only the head pressure of measured liquid is applied to the transmitter. Therefore, the transmitter measurement range is equal to $H \cdot \rho$, and the transmitter output increases as the liquid level rises.

When the liquid level cannot be lowered to the zero point check level, check the output at a known liquid level above the 0% liquid level + 48mm.

When the high pressure side flange is mounted below the minimum measurement liquid level (0% level), the sum of $H \cdot \rho$ and the elevation head $E \cdot \rho$ is applied to the high pressure side diaphragm at the maximum measurement liquid level (100% level). Therefore, the transmitter output should be set to equal 0% at the 0% level by canceling $E \cdot \rho$ at the LRV (0% level value). Also, caution is required when the high pressure side flange and the low pressure side flange are mounted at different positions. For example, when the low pressure side flange is mounted below the high pressure side flange, elevation $E' \cdot \rho$ (E' : Difference in position, ρ' : Specific gravity of fill fluid) is applied. When the high pressure side is mounted above the low pressure side, suppression occurs. Therefore, the transmitter output should be set to 0% by canceling the elevation or suppression.

When the liquid level cannot be lowered to the 0% level, check the output at a known liquid level above 0%.

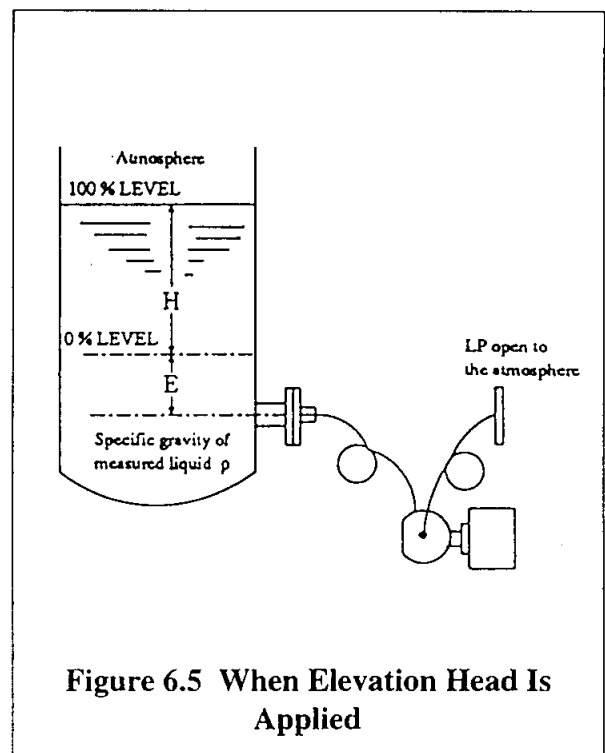
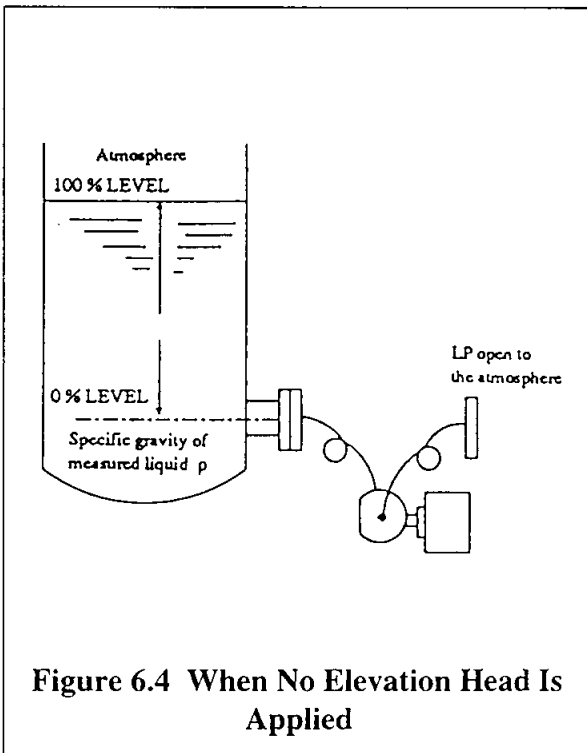

(1) Read the input on the SFC.

SHIFT	SHIFT -												
INPUT OUTPUT	INPUT T1 2 3 4 5 6 7												
	WORKING . . .												
INPUT T1 2 3 4 5 6 7													
0 . 0 0 k P a													

(2) Display % output on the SFC and read the output from the ammeter at the same time. Check both values.

INPUT OUTPUT	OUTPUT T1 2 3 4 5 6 7												
	WORKING . . .												
OUTPUT T1 2 3 4 5 6 7													
0 . 0 0 %													

(3) If the values displayed in (1) and (2) are not equivalent to 0 (differential pressure), correct the zero display by the following procedure, using the SFC.

① Read the input on the SFC

SHIFT	SHIFT -												
INPUT OUTPUT	INPUT T1 2 3 4 5 6 7												
	WORKING . . .												
INPUT T1 2 3 4 5 6 7													
0 . 5 0 k P a													

RESET COR- RECT	D S T J T1 2 3 4 5 6 7												
	Z E R O I N P U T ?												

The display asks whether zero input may be given.

NON-VOL ENTER (Yes)	D S T J T1 2 3 4 5 6 7												
	W O R K I N G . . .												

D S T J T1 2 3 4 5 6 7												
I N P U T Z E R O E D												

Zero point correction has been completed.

- (4) Repeat (1) and (2) to make sure that the zero point has been corrected.
- (5) Apply the liquid level to the transmitter as pressure.
- (6) Read the input and output on the SFC (or the output on the ammeter) and check the relation between the input and output. If the input and output fail to match, check to see if the transmitter is installed and piped adequately. If the input and output fail to have adequate correspondence, check the configuration data base of the transmitter and check to see if the set range of the transmitter is wrong. If the problem cannot be solved by the above method, refer to 11. "Troubleshooting".

6.2.3 Liquid Level Measurement in a Closed Tank

In the case of a closed tank, connect the L side flange to the lower part of the tank and the H side flange to the upper part of the tank, because the pressure on the lower side (A side) is lower than that on the higher side (B side).

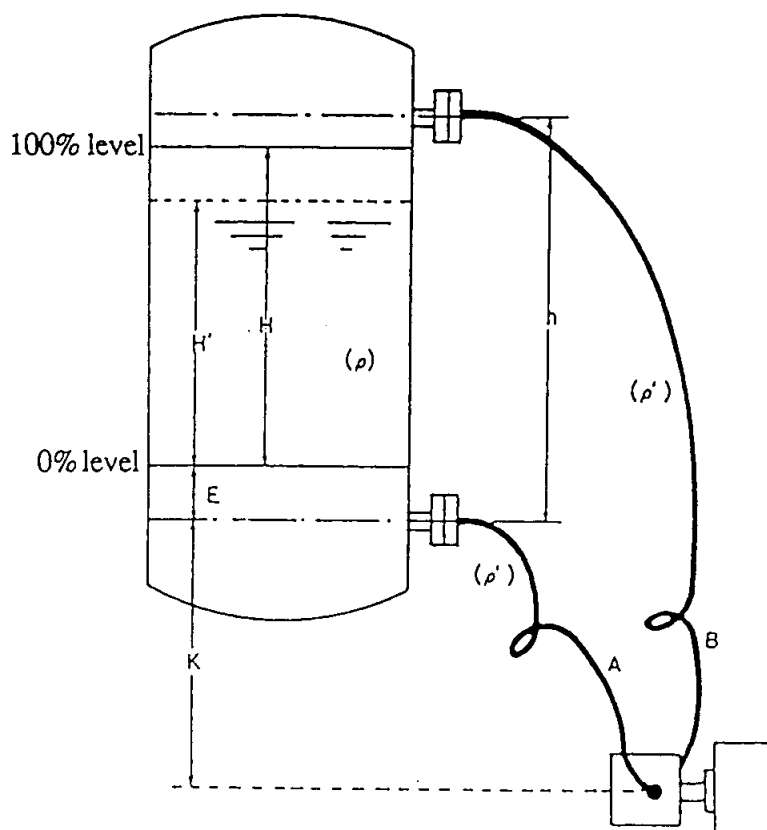

Figure 6.6 Liquid Level Measurement of Closed Tank

The pressures in Figure 6.6 are as follows.

Pressure applied to A side: $(H' + E) \rho + K\rho' + \text{Pressure in container}$

Pressure applied to B side: $h\rho' + K\rho' + \text{Pressure in container}$

Since $(H + E)\rho$ is ordinarily smaller than $h\rho'$, $(H' + E)\rho$ is smaller than $h\rho'$.

Note) Set the transmitter ranges LRV (0% level value) and URV (100% level value) by referring to the following examples.

[Example]

$h=2\text{m}$, $E=0.5\text{m}$, $H=1.5\text{m}$, $\rho=0.9\text{m}$, $\rho'=0.935$

Differential pressure at 0% level: $h \cdot 0.0098 \cdot \rho' - E \cdot 0.0098 \cdot \rho = 13.92 \text{ kPa}$

Differential pressure at 100% level: $h \cdot 0.0098 \cdot \rho' - (H + E) \cdot 0.0098 \cdot \rho = 0.69 \text{ kPa}$

Therefore, LRV and URV should be set as follows.

$$\text{LRV} = 13.92 \text{ kPa}$$

$$\text{URV} = 0.69 \text{ kPa}$$

- (1) Apply the liquid level onto the transmitter as pressure.
- (2) Read the input and output on the SFC (or the output on the ammeter) and check the relation between the input and output. If the input and output fail to correspond, check to see if the transmitter is installed and piped correctly.

If the input and output fail to correspond even-if the installation and piping are correct, check the configuration database of the transmitter to see if the set range of the transmitter is incorrect. If the problem cannot be solved by the above method, refer to the SFC troubleshooting manual.

6.2.4 Temperature Compensation of Fill Fluid in Capillary

When the liquid level of a tank is measured using a remote-seal type differential pressure transmitter, a zero shift of several percent (%) will ordinarily arise because of variation in the density of the fill fluid in the capillary tube.

This transmitter can measure the liquid level accurately because a composite semiconductor sensor is used to measure the temperature and a micro processor is used to compensate for the fill fluid temperature. (The zero shift is 1/5 that of a conventional transmitter.)

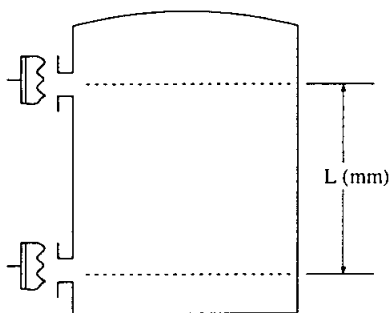

Example of zero shift

L (Difference between flanges): 2500mm (2.5m)

R (Measurement span): 2500mm (2.5m)

A (Temperature coefficient of fill fluid): $0.001/^\circ\text{C}$

T (Ambient temperature change): 55°C

$$\text{Zero shift} = \frac{A \times T \times L}{R} \times 100 \dots\dots\dots(1)$$

From (1)

With no temperature compensation: $\frac{0.001 \times 55 \times 2500}{2500} \times 100 = 5.5\%$
(Conventional transmitter)

ST 3000 with temperature compensation function: 1%

6.2.5 Flow Rate Measurement

Refer to "Mounting the Flanges for Flow Rate Measurement" for information about operating the transmitter for flow rate measurement.

Since neither an equalizer valve, nor a stop valve can be installed in this case due to the structural nature of the instrument, check the zero point before allowing fluid to flow into the main pipe.

When the differential pressure outlet flange port is mounted on a vertical pipe, there will be a difference in height between the high and low pressure side flanges. In this case, determine the zero point by setting the LRV.

Start operation immediately after performing the above preparations.

Remarks:

The product of the specific gravity of the fill fluid in the capillary tube and the relative positions (high, low) of the flange installation and the pressure receiving unit of the transmitter has an effect on the pressure receiving unit as a pressure in accordance with the relative positions. This is applicable to both liquid level measurement and flow rate measurement as well as to both the high pressure side flange and the low pressure side flange.

This effect must be corrected for by addition when the flange position is higher than the pressure receiving unit and by subtraction in the opposite case. However, values outside the range given in the "Specifications" cannot be corrected for. No measurement can be made in such cases.

It is recommended that the pressure receiving unit be mounted below the two flanges if possible. It is especially important to mount it below the high and low pressure side flanges when the pressure in the tank is a vacuum.

6.3 Zero Adjustment for Liquid Level Measurement (Intermediate Level)

It is easy to adjust the zero point of a level gauge to an intermediate level between 0 and 100 (50% for example).

Read the actual level value using the level gauge. (This is assumed to be 50% here.)

INPUT

J	
OUT-	
PUT	

O	U	T	P	U	T	T	1	2	3	4	5	6	7
W	O	R	K	I	N	G	.	.	.				

O	U	T	P	U	T	T	1	2	3	4	5	6	7
4	5	.	0	0	%								

The transmitter displayed 45%.

S	
5	

O	U	T	P	U	T	T	1	2	3	4	5	6	7
5	-				%								

Key in 50%.

ACT PR

Z	
0	

O	U	T	P	U	T	T	1	2	3	4	5	6	7
5	0	-			%								

TOTAL

G	
SET	

O	U	T	P	U	T	T	1	2	3	4	5	6	7
S	E	T	,	R	E	Q	L	E	V	E	L	?	

The display asks whether zero adjustment may be made at 50%.

NON-VOL

ENTER	
(Yes)	

O	U	T	P	U	T	T	1	2	3	4	5	6	7
5	0	.	0	0	%								

Zero adjustment at 50% was completed.

6.4 Starting Operation

When the power is turned on, or when the power is turned off for more than 1 second, the output will first be set to about 4 mA and often several seconds it will begin to change according to the input.

6.5 Configuration (Setting)

This section is concerned with the configuration data parameters of the transmitter. It explains how to write data into the memory of the transmitter using the SFC (Smart Communicator).

6.5.1 Configuration Data Parameters (Various Settings)

The configuration data parameters of a transmitter are shown in Table 6.1.

Since the SFC supports various types of transmitters, some of the data are not necessary for a differential pressure or pressure transmitter. Select the necessary data.

Table 6.1 (The item numbers correspond to the title numbers in 6.4.3.)

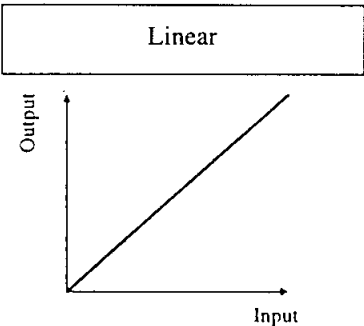
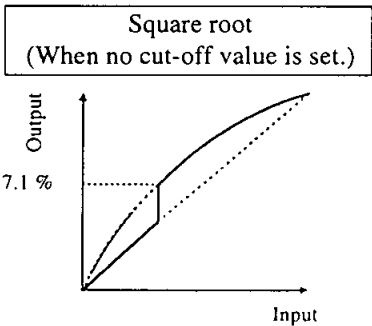
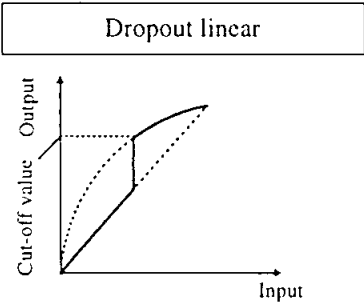
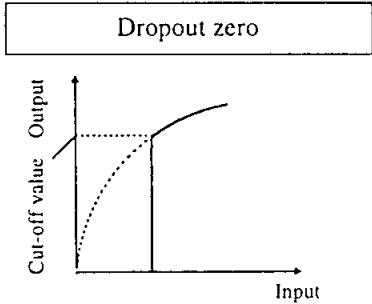
Data parameter	Selections
(1) Output signal type	Analog transmission
(2) Transmitter tag No. registration	8 characters or less
(3) Output format	<p>Select LINEAR or SQUARE ROOT. When SQUARE ROOT is selected, a cut-off value (0 to 20%), a dropout format (linear/zero) and a flow rate mode (DEFAULT/EXPAND) etc. can be selected.</p> <div style="display: flex; justify-content: space-around;"> <div style="text-align: center;"> <p>Linear</p>  </div> <div style="text-align: center;"> <p>Square root (When no cut-off value is set.)</p>  </div> </div> <div style="text-align: center; margin: 10px 0;"> <p>Square root (When a cut-off value is set.)</p> </div> <div style="display: flex; justify-content: space-around;"> <div style="text-align: center;"> <p>Dropout linear</p>  </div> <div style="text-align: center;"> <p>Dropout zero</p>  </div> </div> <p>Note) Flow rate mode DEFAULT : This mode is used in most cases. EXPAND : This mode is selected when the range is expanded (for example, when the range is set near the normal flow rate) or when reverse flow rate output must be obtained using a reversible orifice.</p>

Data parameter	Selections														
(4) Damping time constant	<p>Can be selected from the following 10 values (Unit : second). However, the actual response time is the value obtained by adding 0.4 sec. to the selected value.</p> <table style="margin-left: auto; margin-right: auto;"> <tr> <td>0.00</td> <td>1.</td> <td>16.</td> </tr> <tr> <td>0.16</td> <td>2.</td> <td>32.</td> </tr> <tr> <td>0.32</td> <td>4.</td> <td></td> </tr> <tr> <td>0.48</td> <td>8.</td> <td></td> </tr> </table>	0.00	1.	16.	0.16	2.	32.	0.32	4.		0.48	8.			
0.00	1.	16.													
0.16	2.	32.													
0.32	4.														
0.48	8.														
(5) Pressure unit	<p>One of the following units can be selected.</p> <table style="margin-left: auto; margin-right: auto;"> <tr> <td>kPa</td> <td>MPa</td> <td>hPa</td> <td>Pa</td> <td>mbar</td> <td>bar</td> <td>inH₂O</td> </tr> <tr> <td>inHg</td> <td>PSI</td> <td>mmH₂O</td> <td>mH₂O</td> <td>kgf/cm²</td> <td>gf/cm²</td> <td>mmHg</td> </tr> </table>	kPa	MPa	hPa	Pa	mbar	bar	inH ₂ O	inHg	PSI	mmH ₂ O	mH ₂ O	kgf/cm ²	gf/cm ²	mmHg
kPa	MPa	hPa	Pa	mbar	bar	inH ₂ O									
inHg	PSI	mmH ₂ O	mH ₂ O	kgf/cm ²	gf/cm ²	mmHg									
(6) Low limit of set range LRV (measured value for outputting 0% (4 mA DC))	Set a value using the keys or set the pressure value outputted to the SFC.														
High limit of set range URV (measured value for outputting 100% (20 mA DC))	Set a value using the keys or set the pressure value outputted to the SFC.														
(7) Saving data to SFC (save) and restoring to transmitter (re-input)	Data can be saved and restored from the SFC to the transmitter and vice versa.														

- (Notes) (1) Transmitter tag No. registration: A maximum of 8 characters can be inputted using numerics, characters and symbol marks on the keyboard of the SFC.
- (2) The set range is displayed in 4.5 digits.

6.5.2 Connecting the SFC (Smart Field Communicator) and External Meter

- (1) Connect the SFC and a high precision ammeter to the terminal board as shown in Figure 6.6. The SFC can be connected to the panel terminal in an instrument room or in the field, according to the purpose. Dismount the case cover of the transmitter.
- Connect the lead wires of the SFC to the + and the - tabs of the SUPPLY terminal. Make sure that the polarity is correct. Connect the lead wires of the meter to the test terminals CHK+ and CHK-. Make sure that the polarity is correct.
- At the same time, refer to Smart Communicator Operation Manual OM2-5254-0800.

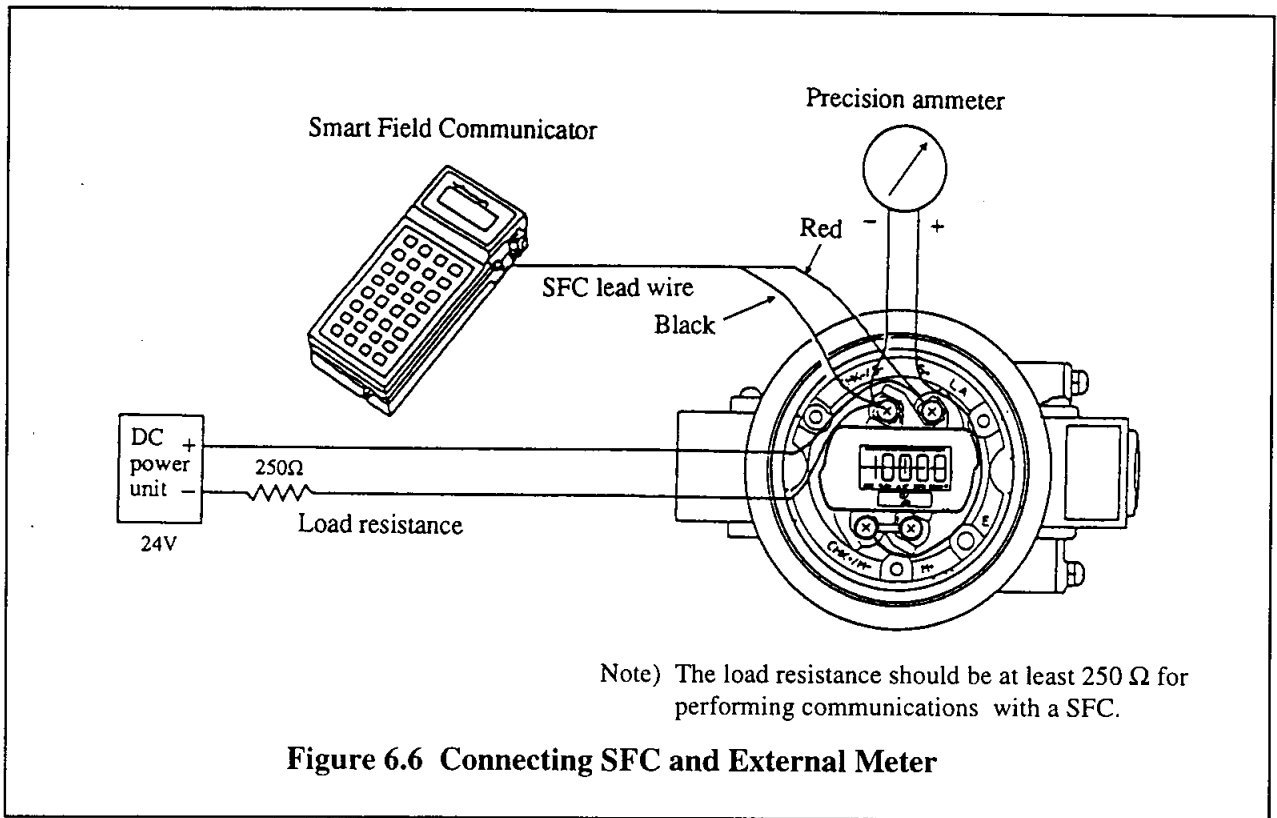

(2) Turn on the SFC.

L	O	O	P	I	N	M	A	N	U	A	L	?		
P	R	E	S	S	I	D								

The display asks to press the ID key.

(3)

DE READ
A
ID

T	A	G	N	O	.									
W	O	R	K	I	N	G	.	.	.					

D	S	T	J			T	A	G	N	O	.			
L	I	N		D	P	x	x	x	x	x	x	x	x	x

6.5.3 Writing Configuration Data

Configuration data can be written to the memory of the transmitter or the memory of the SFC.

(1) Registering the transmitter tag number

Turn on the SFC.

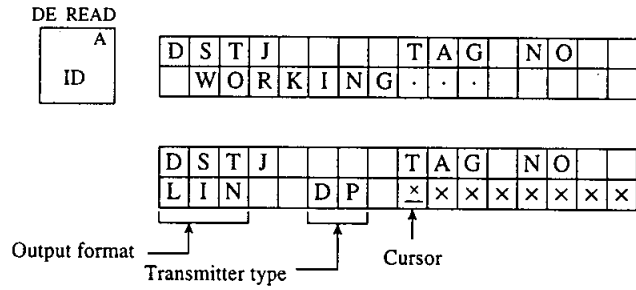

- Note 1. The tag number is "xxxxxxxx" at the time of plant shipment.
- Note 2. LIN (output format) means linear output.
(SQRT means square root output.)
- Note 3. DP (transmitter type) means a differential pressure transmitter. (GP and AP mean a process pressure transmitter and an absolute pressure transmitter, respectively.)

Select the alphabet mode.

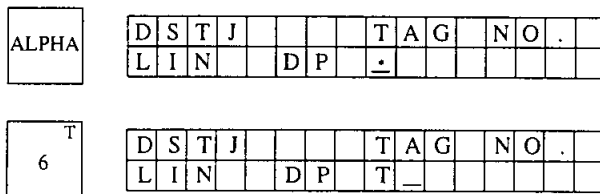

Release the alphabet mode.

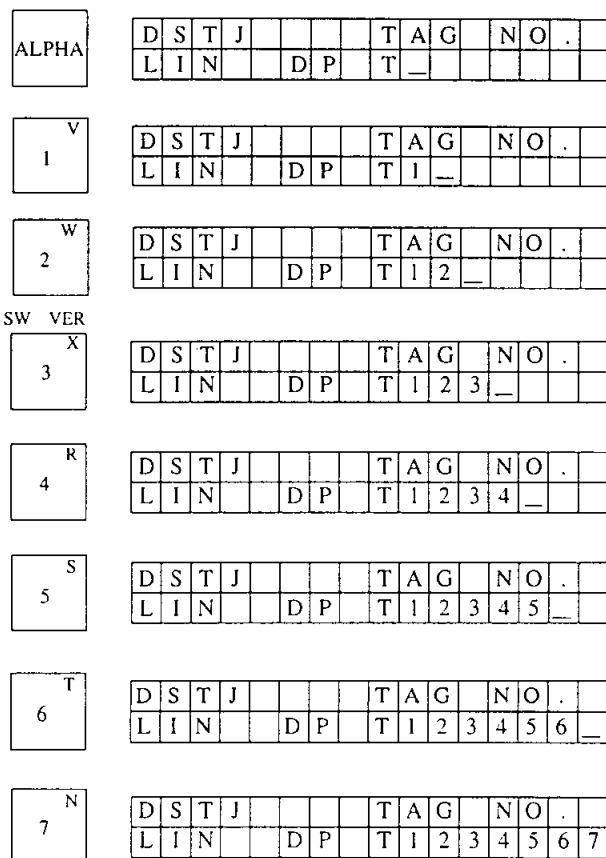

Write the data to the memories of the transmitter and the SFC.

NON-VOL

ENTER
(Yes)

D	S	T	J				T	A	G	N	O		
W	O	R	K	I	N	G	.	.	.				

D	S	T	J				T	A	G	N	O	.		
L	I	N			D	P	T	1	2	3	4	5	6	7

(2) Saving data in the non-volatile memory (NVM) of the transmitter

After zero and span calibration, save the calibration data in the non-volatile memory of the transmitter by the following procedure. The data in the work memory of the transmitter can be saved with high priority. The data will not be lost even if the transmitter is turned off. When any value in the work memory is changed, ST3000 automatically saves data from the work memory to the NVM in about 30 seconds, even without this operation.

SHIFT [^]

					S	H	I	F	T	-				

NON-VOL

ENTER
(Yes)

D	S	T	J				T	1	2	3	4	5	6	7
W	O	R	K	I	N	G	.	.	.					

Data is saved to the NVM.
This operation takes about 8 seconds.

D	S	T	J				T	1	2	3	4	5	6	7	
D	A	T	A		N	O	N	V	O	L	A	T	I	L	E

The operation has ended.

(3) Output format

① Linear output

^B
CONF

D	S	T	J		C	O	N	F	I	G				
C	O	N	F	O	R	M	?							

NON-VOL

ENTER
(Yes)

C	O	N	F	O	R	M								
	S	Q	U	A	R	E		R	O	O	T			

OR

C	O	N	F	O	R	M								
					L	I	N	E	A	R				

MENU

C	O	N	F	O	R	M								
					L	I	N	E	A	R				

MENU

Select LINEAR using the [MENU] key.

ENTER
(Yes)

C	O	N	F	O	R	M								
E	N	T	E	R	D		I	N	S	F	C			

C	O	N	F	O	R	M								
					L	I	N	E	A	R				

H ▲ MENU	C	O	N	F	O	R	M								
	D	O	W	N		L	O	A	D		D	A	T	A	?

ENTER (Yes)	C	O	N	F	O	R	M								
		W	O	R	K	I	N	G							

C	O	N	F	O	R	M									
D	A	T	A		L	O	A	D	E	D		!			

② Square root output
 ②-1 When no cut-off value is set:

CONF	D	S	T	J		C	O	N	F	I	G				
	C	O	N	F	O	R	M	?							

NON-VOL

ENTER (Yes)	C	O	N	F	O	R	M								
		S	Q	U	A	R	E		R	O	O	T			

OR

C	O	N	F	O	R	M									
				L	I	N	E	A	R						

MENU	C	O	N	F	O	R	M								
		S	Q	U	A	R	E		R	O	O	T			

MENU Select SQUARE ROOT using the [MENU] key.

NON-VOL

ENTER (Yes)	C	O	N	F	O	R	M								
		E	N	T	E	R	D		I	N	S	F	C		

C	O	N	F	O	R	M									
	S	Q	U	A	R	E		R	O	O	T				

H ▲ NEXT	C	O	N	F	O	R	M								
	D	O	W	N		L	O	A	D		D	A	T	A	?

NON-VOL

ENTER (Yes)	C	O	N	F	O	R	M								
		W	O	R	K	I	N	G							

C	O	N	F	O	R	M									
D	A	T	A		L	O	A	D	E	D		!			

②-2 When a cut-off value is set:

CONT	D	S	T	J	C	O	N	F	I	G				
	C	O	N	F	O	R	M	?						

NON-VOL

ENTER (Yes)	C	O	N	F	O	R	M							
			S	Q	U	A	R	E		R	O	O	T	

OR

C	O	N	F	O	R	M								
				L	I	N	E	A	R					

MENU	C	O	N	F	O	R	M							
			S	Q	U	A	R	E		R	O	O	T	

MENU Select SQUARE ROOT using the [MENU] key.

▲ ^H	C	U	T	O	F	F								
			D	E	F	A	U	L	T					

MENU	C	U	T	O	F	F								
			-						%					

Set a cut-off value using numeric keys.

Set 15% as the cut-off value in this example.

V 1	C	U	T	O	F	F								
			1	-					%					

S 5	C	U	T	O	F	F								
			1	5					%					

ENTER	C	O	N	F	O	R	M							
			E	N	T	E	R	D		I	N	S	F	C

C	U	T	O	F	F									
		1	5					%						

②-3 Setting a dropout format (LINEAR/ZERO)

After setting a cut-off value in ②-②

H ▲ NEXT	C	U	T	O	F	F								
	D	R	O	P	O	U	T	=	Z	E	R	O		

MENU	C	U	T	O	F	F								
	D	R	O	P	O	U	T	=	L	I	N			

MENU Select LINEAR or ZERO using the [MENU] key.

Select LINEAR in this example.

MENU	C	U	T	O	F	F								
	D	R	O	P	O	U	T	=	L	I	N			

ENTER (Yes)	C	U	T	O	F	F								
	E	N	T	E	R	D	I	N	S	F	C			

C	U	T	O	F	F									
D	R	O	P	O	U	T	=	L	I	N				

②-4 Setting a flow rate mode (DEFAULT/EXPAND)

After setting a cut-off value and a dropout format in ②-2 and ②-3 respectively

▲^H
NEXT

C	U	T	O	F	F										
	M	O	D	E		=		D	E	F	A	U	L	T	

MENU

Select DEFAULT or EXPAND using the [MENU] key.

OR

MENU

C	U	T	O	F	F										
	M	O	D	E		=		E	X	P	A	N	D		

Select DEFAULT in this example.

MENU

C	U	T	O	F	F										
	M	O	D	E		=		D	E	F	A	U	L	T	

ENTER
(Yes)

C	U	T	O	F	F										
		E	N	T	E	R	D	I	N	S	F	C			

C	U	T	O	F	F										
	M	O	D	E		=		D	E	F	A	U	L	T	

▲^H
NEXT

C	O	N	F	O	R	M									
	D	O	W	N		L	O	A	D		D	A	T	A	?

ENTER
(Yes)

C	O	N	F	O	R	M									
		W	O	R	K	I	N	G							

C	O	N	F	O	R	M									
	D	A	T	A		L	O	A	D	E	D		!		

(4) Displaying and changing the indicator display format

Introduction:

The procedure for displaying and changing the indicator display format is explained here.

- When the output format is “Square Root Extraction,” the display format is fixed to “Flow Rate.”
- When the output format is “Linear,” either “Linear” or “Display Flow Rate” can be selected for the display format.

Remarks:

- Display Flow Rate: In some cases, the transmitter must output “linear” data as required by higher level equipment that perform arithmetic operations for flow rate control. In such cases, select “Display Flow Rate” to display the flow rate on the display only.
- For detailed information on the indicator display, refer to Item 13.

Procedure

Check and change the display format (linear/display flow rate) of the transmitter indicator using the following procedure:

B CONF	D	S	T	J	C	O	N	F	I	G				
	C	O	N	F	O	R	M	?						

H ▲ NEXT	D	S	T	J	C	O	N	F	I	G				
	D	I	S	P	L	A	Y	?						

NON-VOL ENTER (Yes)	D	I	S	P	L	A	Y	C	O	N	F			
	F	L	O	W				*	I)				

(Output format: Square root extraction)

or

D	I	S	P	L	A	Y	C	O	N	F				
L	I	N	E	A	R									

(Display format: Linear)

or

D	I	S	P	L	A	Y	C	O	N	F				
D	I	S	P	F	L	O	W							

(Display format: Display flow rate)

CLR (No)	D	I	S	P	L	A	Y	C	O	N	F			
	D	I	S	P	F	L	O	W						

If unchanged.

OR

DE CONF MENU ITEM	D	I	S	P	L	A	Y	C	O	N	F			
	L	I	N	E	A	R								

If changed, or when changing.

NON-VOL

ENTER
(Yes)

D	I	S	P	L	A	Y	C	O	N	F				
E	N	T	E	R	E	D	I	N	S	F	C			

D	I	S	P	L	A	Y	C	O	N	F				
D	I	S	P	F	L	O	W							

H
▲
NEXT

or

CLR
(No)

D	I	S	P	L	A	Y								
D	O	W	N	L	O	A	D	D	A	T	A	?		

NON-VOL

ENTER
(Yes)

D	I	S	P	L	A	Y								
W	O	R	K	I	N	G	.	.	.					

D	I	S	P	L	A	Y								
D	A	T	A	L	O	A	D	E	D	!				

• The display format changes to "Linear" or "Display Flow Rate."

SHIFT

D	I	S	P	L	A	Y								
				S	H	I	F	T	-					

CLR
(No)

D	S	T	J	F	I	T	-	1	2	3	4			
R	E	A	D	Y										

SHIFT

D	S	T	J	F	I	T	-	1	2	3	4			
				S	H	I	F	T	-					

NON-VOL

ENTER
(Yes)

D	S	T	J	F	I	T	-	1	2	3	4			
W	O	R	K	I	N	G	.	.	.					

D	S	T	J	F	I	T	-	1	2	3	4			
D	A	T	A	N	O	N	V	O	L	A	T	L	E	

• The data has been saved in the transmitter.

(5) Displaying and changing the engineering unit high and low limits

Introduction:

The procedure for setting the high and low limits for the engineering unit is explained here.

Procedure:

Display and change the high and low limits for the engineering unit displayed on the indicator using the following procedure:

B
CONF
^H
▲
NEXT
NON-VOL
ENTER
(Yes)
^H
▲
NEXT

The present indication type (engineering unit or %) is known.

D	I	S	P	L	A	Y	T	Y	P	E				
%	(0	.	0)									

Indication in %

OR

D	I	S	P	L	A	Y	T	Y	P	E					
E	N	G	.	U	N	I	T	(4	.	5	F	I	G)

Indication in engineering units

DE CONF
I
MENU
ITEM
NON-VOL
ENTER
(Yes)

If changed, or when changing

OR

CLR
(No)
CLR
(No)

If unchanged

Changing the high and low limits

B
CONF
^H
▲
NEXT
NON-VOL
ENTER
(Yes)
^H
▲
NEXT

D	I	S	P	L	A	Y	T	Y	P	E				
E	N	G	.	U	N	I	T							

^H
▲
NEXT

E	U	L	O	(a	t	0	%)					

• Following shows how to set -10.0 as the low limit for the engineering unit.

TIME
+/-
^V
I
ACT PR
0^Z
SCR PAD
-
ACT PR
0^Z

E	U	L	O	(a	t	0	%)					
-	1	0	.	0										

NON-VOL
ENTER
(Yes)

E	U	L	O	(a	t	0	%)					
	E	N	T	E	R	E	D	I	N	S	F	C		

E	U	L	O	(a	t	0	%)					
-	1	0	.	0										

• The low limit (-10.0) for the engineering unit has been set.

H
▲
NEXT

E U H I (a t 1 0 0 %)

• Steps 7 and 8 show how to set 50.0 as the high limit for the engineering unit.

S
5

ACT PR SCR PAD ACT PR
Z - Z
0 . 0

E U H I (a t 1 0 0 %)
5 0 . 0

NON-VOL

ENTER
(Yes)

E U H I (a t 1 0 0 %)
E N T E R E D I N S F C

E U H I (a t 1 0 0 %)
5 0 . 0

• The high limit (50.0) for the engineering unit has been set.

H
▲
NEXT

D I S P L A Y
D O W N L O A D D A T A ?

NON-VOL

ENTER
(Yes)

D I S P L A Y
W O R K I N G . . .

D I S P L A Y
D A T A L O A D E D !

• The high and low limits for the engineering unit have been changed to the newly set values.

SHIFT

CLR
(No)

D I S P L A Y
S H I F T -

D S T J F I T - 1 2 3 4
R E A D Y

SHIFT

NON-VOL

ENTER
(Yes)

D S T J F I T - 1 2 3 4
S H I F T -

D S T J F I T - 1 2 3 4
W O R K I N G . . .

D S T J F I T - 1 2 3 4
D A T A N O N V O L A T L E

• The data has been saved in the transmitter.

(6) Damping time constant



D	A	M	P	I	N	G	T	1	2	3	4	5	6	7
	1	.	0				S	E	C	O	N	D	S	

One of the 10 values is displayed.
The display shown on the left is an example.



D	A	M	P	I	N	G	T	1	2	3	4	5	6	7
	W	O	R	K	I	N	G	.	.	.				

D	A	M	P	I	N	G	T	1	2	3	4	5	6	7
	2	.	0				S	E	C	O	N	D	S	

The next higher value is displayed and inputted to the memories of the transmitter and the SFC.



D	A	M	P	I	N	G	T	1	2	3	4	5	6	7
	W	O	R	K	I	N	G	.	.	.				

The next lower value is displayed and inputted to the memories of the transmitter and the SFC.

D	A	M	P	I	N	G	T	1	2	3	4	5	6	7
	1	.	0				S	E	C	O	N	D	S	

The damping time constant can be changed by pressing the keys successively.

Save the data to the non-volatile memory by referring to section (3).

(7) Engineering unit



U	N	I	T				T	1	2	3	4	5	6	7
							k	P	a					

One of the 11 units can be selected. (kPa is an example.) The next unit will be displayed and saved in the memory of the SFC each time the "UNITS" key is pressed.



U	N	I	T				T	1	2	3	4	5	6	7
							M	P	a					

The immediately following unit is displayed and saved in the memory of the SFC.

OR



U	N	I	T				T	1	2	3	4	5	6	7
							m	m	H	g				

The immediately preceding unit is displayed and saved in the memory of the SFC.

(8) Range

The low limit (LRV) and the high limit (URV) of the range can be set by two methods. In other words, they can be set by keying in numerical values or by applying a pressure that is equal to the high and low limit values, and those values are set.

- (Note) ① In order to reverse the range, set the high limit as the LRV and the low limit as the URV. For example, if the range is from 50 kPa to 0kPa {5000 mmH₂O to 0 mmH₂O}, set 50{5000} as the LRV and 0 as the URV.
- ② When the LVR is changed, the URV value is automatically ranged, leaving the span unchanged.
- ③ To change both the LRV and the URV, set the value for the LRV before setting the value for the URV.

① Setting by keying-in operation

Setting the LRV {Measured value for outputting 0% (4 mA DC)}

Example : Change from 10kPa to 0 kPa.

^E
LRV
0%

L	R	V				T	1	2	3	4	5	6	7
	1	0				k	P	a					

The SFC displays the current LRV.

ACT PR
^Z
0

L	R	V				T	1	2	3	4	5	6	7
	0					k	P	a					

New LRV that was keyed in

NON-VOL
ENTER
(Yes)

L	R	V				T	1	2	3	4	5	6	7
	W	O	R	K	I	N	G	.	.	.			

This data is loaded into the memories of the transmitter and the SFC, and the new LRV is displayed at the same time.

L	R	V				T	1	2	3	4	5	6	7
	0	.	0	0	0	k	P	a					

Setting the URV {Measured value for outputting 100% (20 mA DC)}

Example: Change from 50kPa to 80kPa.

^F
URV
100%

U	R	V				T	1	2	3	4	5	6	7
	5	0				k	P	a					

The SFC displays the current URV.

FEED
^O
8

U	R	V				T	1	2	3	4	5	6	7
	8					k	P	a					

New URV that was keyed in

ACT PR
^Z
0

U	R	V				T	1	2	3	4	5	6	7
	8	0				k	P	a					

ENTER
(Yes)

U	R	V					T	1	2	3	4	5	6	7
	W	O	R	K	I	N	G	.	.	.				

This data is loaded into the memories of the transmitter and the SFC, and the new URV is displayed at the same time.

U	R	V					T	1	2	3	4	5	6	7
	8	0					k	P	a					

Save the data to the non-volatile memory by referring to (2).

② Setting by input pressure

Setting the LRV {Measured value for outputting 0% (4 mA DC)}

Apply the liquid level or input value that is equal to the target LRV to the transmitter, and set it after checking the input value.

^E
LRV
0%

L	R	V					T	1	2	3	4	5	6	7
	0	.	0				k	P	a					

The SFC displays the current LRV.

^G
SET

L	R	V					T	1	2	3	4	5	6	7
			S	E	T	L	R	V	?					

The SFC asks whether to set the currently applied pressure as the LRV.

NON-VOL

ENTER
(Yes)

L	R	V					T	1	2	3	4	5	6	7
	W	O	R	K	I	N	G	.	.	.				

Press the "ENTER" key, and the data will be loaded into the memories of the transmitter and the SFC.

L	R	V					T	1	2	3	4	5	6	7
	0	.	0				k	P	a					

After the data is loaded to the memory, the new LRV is displayed.

Setting the URV {Measured value for outputting 100% (20 mA DC)}

Apply the liquid level or input value that is equal to the target URV to the transmitter, and set it after checking the input value.

^F
URV
100%

U	R	V					T	1	2	3	4	5	6	7
	8	0					k	P	a					

The SFC displays the current URV.

^G
SET

U	R	V					T	1	2	3	4	5	6	7
			S	E	T	U	R	V	?					

The SFC asks whether to set the currently applied pressure as the URV.

NON-VOL

ENTER
(Yes)

U	R	V					T	1	2	3	4	5	6	7
	W	O	R	K	I	N	G	.	.	.				

Press the "ENTER" key, and the data will be loaded into the memories of the transmitter and the SFC.

U	R	V					T	1	2	3	4	5	6	7
	8	0					k	P	a					

After the data is loaded to the memory, the new LRV is displayed.

Save the data to the non-volatile memory by referring to (2).

(9) Compensating for the temperature of the fill fluid in the capillary.

SHIFT S H I F T -

^N
7 H E I G H T T 1 2 3 4 5 6 7
W O R K I N G . . .

H E I G H T T 1 2 3 4 5 6 7
0 . 0 0 0 m

The currently set inter-flange height is displayed.
"0m" means no temperature compensation.

Input the inter-flange height. ("2m" is inputted here as an example.)

^W
2 H E I G H T T 1 2 3 4 5 6 7
2 m

^B
ENTER H E I G H T T 1 2 3 4 5 6 7
W O R K I N G . . .

H E I G H T T 1 2 3 4 5 6 7
2 . 0 0 0 m

Temperature compensaion was made for a flange height of 2m.

(10) Saving (storing) configuration data from the transmitter to the SFC and restoring (re-entering) data saved in the SFC to the transmitter

① Saving (storing) all the data in the work memory of the transmitter to the hold memory of the SFC

DE READ
^A
ID T A G N O .
W O R K I N G . . .

D S T J T A G N O .
L I N D P T 1 2 3 4 5 6 7

Currently stored ID

^B
CONF D S T J C O N F I G
C O N F O R M ?

^H
NEXT D S T J C O N F I G
S A V E / R E S T O R E ?

NON-VOL
ENTER
(Yes) S A V E / R E S T O R E
S A V E D A T A

ENTER S A V E D A T A
W O R K I N G . . .

Press the "ENTER" key, and the data will be saved to the hold memory of the SFC.

D S T J C O N F I G
S A V E / R E S T O R E ?

② Restoring (re-entering) all the data in the hold memory of the SFC to the work memory of the transmitter

DE READ

A
ID

T	A	G	.	N	O	.											
W	O	R	K	I	N	G	.	.	.								

D	S	T	J			T	A	G	.	N	O	.					
L	I	N		D	P	T	1	2	3	4	5	6	7				

Current, detector ID

B
CONF

D	S	T	J		C	O	N	F	I	G							
C	O	N	F	O	R	M	?										

H
▲
NEXT

D	S	T	J		C	O	N	F	I	G							
S	A	V	E	/	R	E	S	T	O	R	E	?					

ENTER

S	A	V	E	/	R	E	S	T	O	R	E						
S	A	V	E		D	A	T	A									

H
▲
NEXT

S	A	V	E	/	R	E	S	T	O	R	E						
R	E	S	T	O	R	E		D	A	T	A	?					

The SFC asks whether to restore the configuration data in the hold memory to the transmitter.

ENTER

R	E	S	T	O	R	E		D	A	T	A						
W	O	R	K	I	N	G	.	.	.								

Press the "ENTER" key, and the data will be restored from the hold memory of the SFC to the work memory of the transmitter.

D	S	T	J		C	O	N	F	I	G							
S	A	V	E	/	R	E	S	T	O	R	E	?					

6.6 Checking PROM NO and Software No.

6.6.1 Checking PROM NO

The PROM NO is marked on the plate of the meter body. It can be checked from the SFC by the following procedure.

B CONF	D	S	T	J	C	O	N	F	I	G				
	C	O	N	F	O	R	M	?						
L NEXT	D	S	T	J	C	O	N	F	I	G				
	P	R	O	M	N	O	.	?						
NON-VOL ENTER (YES)	P	R	O	M	N	O	.							
	2	0	0	0	0	0	0	0	0	0				

6.6.2 Checking Software No.

The software Nos. of the SFC and the transmitter can be checked by the following procedure.

^ SHIFT					S	H	I	F	T	-				
SW VER X 3	S	/	W	N	O	.								
	S	F	C	=	1	.	0							

When the SFC is not connected to a transmitter, the software No. of the SFC is displayed.

OR

S	/	W	N	O	.	T	1	2	3	4	5	6	7	
S	F	C	=	1	.	0	X	M	T	R	=	2	.	5

When the SFC is connected to a transmitter, the software Nos. of the SFC and the transmitter are displayed.

6.7 Checking Burnout Direction

The burnout direction can be checked from the SFC by the following procedure.

^ SHIFT					S	H	I	F	T	-				
F/S DIR U STAT	D	S	T	J			T	1	2	3	4	5	6	7
	W	O	R	K	I	N	G	.	.	.				
	D	S	T	J			T	1	2	3	4	5	6	7
	F	/	S	A	F	E	N	O	N	-	B	/	O	

↑ or DOWNSCALE or UPSCALE

6.8 Constant Current Source Mode

The transmitter can be used as a constant current source (4 to 20 mA). A constant current can be generated from the SFC by the following procedure.

(Note) When the constant current source mode is selected, the transmitter does not perform pressure measurement.

(Note) The constant current source outputs a value set in the % display.

6.8.1 Generating Constant Current

INPUT																						
OUT-PUT	J	O	U	T	P	U	T	T	1	2	3	4	5	6	7							
			W	O	R	K	I	N	G	.	.	.										

O	U	T	P	U	T	T	1	2	3	4	5	6	7										
	1	0	.	0	0	%																	

The output signal (%) corresponding to the current input pressure is displayed.

Keying in the target output (%) (Example : 50%, 12 mA)

S	5	O	U	T	P	U	T	T	1	2	3	4	5	6	7								
			5	_				%															

Key in an output value (%) for the low current mode.

ACT PR																							
Z	0	O	U	T	P	U	T	T	1	2	3	4	5	6	7								
			5	0	_			%															

O	U	T	P	U	T	T	1	2	3	4	5	6	7										
	W	O	R	K	I	N	G	.	.	.													

NON-VOL																							
ENTER (Yes)		O	U	T	P	U	T	T	1	2	3	4	5	6	7								
			5	0	.	0	0	%															#

The "#" mark indicates that the transmitter is in the constant current source mode. In this example, the transmitter generates a 12 mA constant current.

6.8.2 Releasing Constant Current Source Mode

INPUT																							
OUT-PUT	J	O	U	T	P	U	T	T	1	2	3	4	5	6	7								
			W	O	R	K	I	N	G	.	.	.											

In order to release the constant current source mode, press the "OUTPUT" key.

O	U	T	P	U	T	T	1	2	3	4	5	6	7										
	5	0	.	0	0	%																#	

The SFC displays the output signal in %.

CLR (No)																							
		O	U	T	P	U	T	T	1	2	3	4	5	6	7								
			W	O	R	K	I	N	G	.	.	.											

Then, press the "CLR" key.

O	U	T	P	U	T	T	1	2	3	4	5	6	7										
	R	E	A	D	Y	.	.	.															

The constant current source mode has been released. (Make sure that the "#" mark has disappeared.)

6.9 Scratch Pad (Memo Function to Transmitter)

Two scratch pads, No.1 and No.2, are available. Sixteen alphanumeric characters can be recorded in each of them as memos. The service name, details of operations, trouble history, fixed asset No., etc., can be recorded as memos for each transmitter.

6.9 .1 Entry to Scratch Pad No.1

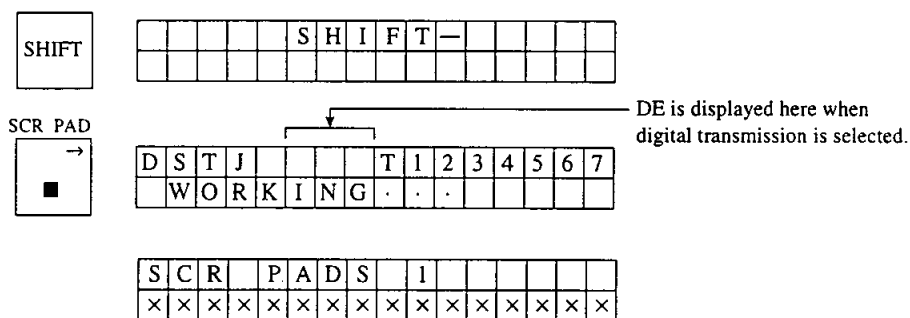

Here, let's enter "90 - 4 ZERO CHECK" as an example.

PRINT

P
9

S	C	R		P	A	D	S		1					
9	x	x	x	x	x	x	x	x	x	x	x	x	x	x

ACT PR

Z
0

S	C	R		P	A	D	S		1					
9	0	<u>x</u>	x	x	x	x	x	x	x	x	x	x	x	x

TIME

1
+/-

S	C	R		P	A	D	S		1					
9	0	-	x	x	x	x	x	x	x	x	x	x	x	x

R
4

S	C	R		P	A	D	S		1					
9	0	-	4	<u>x</u>	x	x	x	x	x	x	x	x	x	x

ALPHA

S	C	R		P	A	D	S		1					
9	0	-	4	<u>x</u>	x	x	x	x	x	x	x	x	x	x

ACT PR

→
■

S	C	R		P	A	D	S		1					
9	0	-	4	<u>x</u>	x	x	x	x	x	x	x	x	x	x

ACT PR

Z
0

S	C	R		P	A	D	S		1					
9	0	-	4	Z	<u>x</u>	x	x	x	x	x	x	x	x	x

E
LRV
0%

S	C	R		P	A	D	S		1					
9	0	-	4	Z	E	<u>x</u>	x	x	x	x	x	x	x	x

R
4

S	C	R		P	A	D	S		1					
9	0	-	4	Z	E	R	<u>x</u>	x	x	x	x	x	x	x

O
8

S	C	R		P	A	D	S		1					
9	0	-	4	Z	E	R	O	<u>x</u>	x	x	x	x	x	x

ACT PR

→
■

S	C	R		P	A	D	S		1					
9	0	-	4	Z	E	R	O	<u>x</u>	x	x	x	x	x	x

SFM CONF

C
DAMP

S	C	R		P	A	D	S		1					
9	0	-	4	Z	E	R	O	C	<u>x</u>	x	x	x	x	x

H
NEXT

S	C	R		P	A	D	S		1					
9	0	-	4	Z	E	R	O	C	H	<u>x</u>	x	x	x	x

E
LRV
0%

S	C	R		P	A	D	S		1					
9	0	-	4	Z	E	R	O	C	H	E	<u>x</u>	x	x	x

SFM CONF

C
DAMP

S	C	R		P	A	D	S		1					
9	0	-	4	Z	E	R	O	C	H	E	C	<u>x</u>	x	x

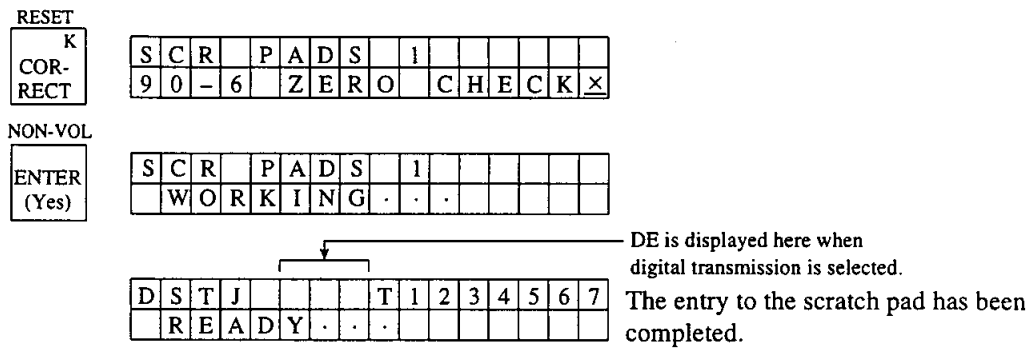

6.9.2 Releasing the Scratch Pad

The scratch pad can be released by pressing the CLR key.

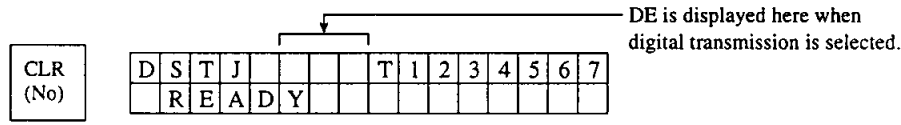

6.9.3 Entry to Scratch Pad No.2

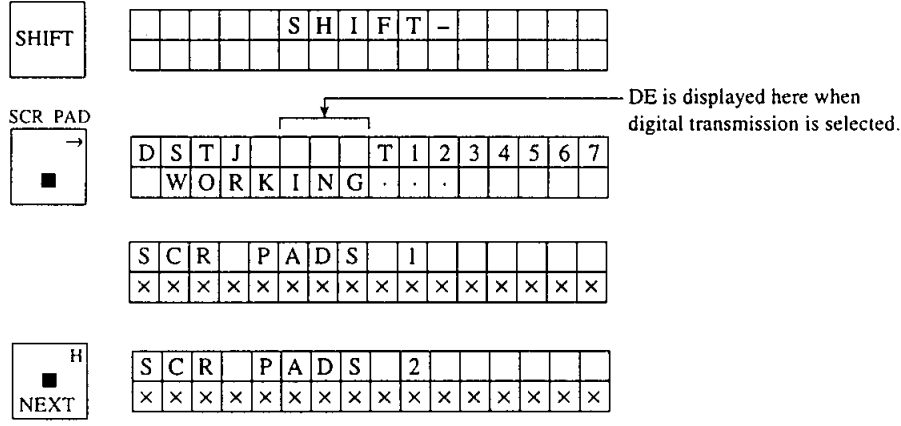

For the subsequent key operations, refer to the instructions for entry to scratch pad No. 1.

7. Calibration

The S-SFC operating instructions in this section are applicable to S-SFC software version 7.1 and later versions.

The transmitter must be calibrated whenever input/output characteristics are abnormal and need to be corrected.

This section explains how to calibrate the ST 3000 transmitter. To ensure the most accurate calibration, calibrate it in the range where it is used. The power unit warm-up time (about 30 minutes) is one of the important factors in calibration accuracy.

If digital transmission is selected, be sure to select analog transmission before calibration.

7.1 Preparation and Setup

- Required preparation

- ① A reference input source having an accuracy of at least 0.04% FS
- ② A voltmeter or precision ammeter having an accuracy of at least 0.03% FS
- ③ Precision resistance (250 Ω)
- ④ SFC (Smart Field Communicator)

- Setup

Set up the equipment as shown in Figure 7.1. Check the connections to make sure that they are correct, and check to make sure that the SFC and the transmitter are in the communication state. (Refer to 6.1.3 Checking Communication.)

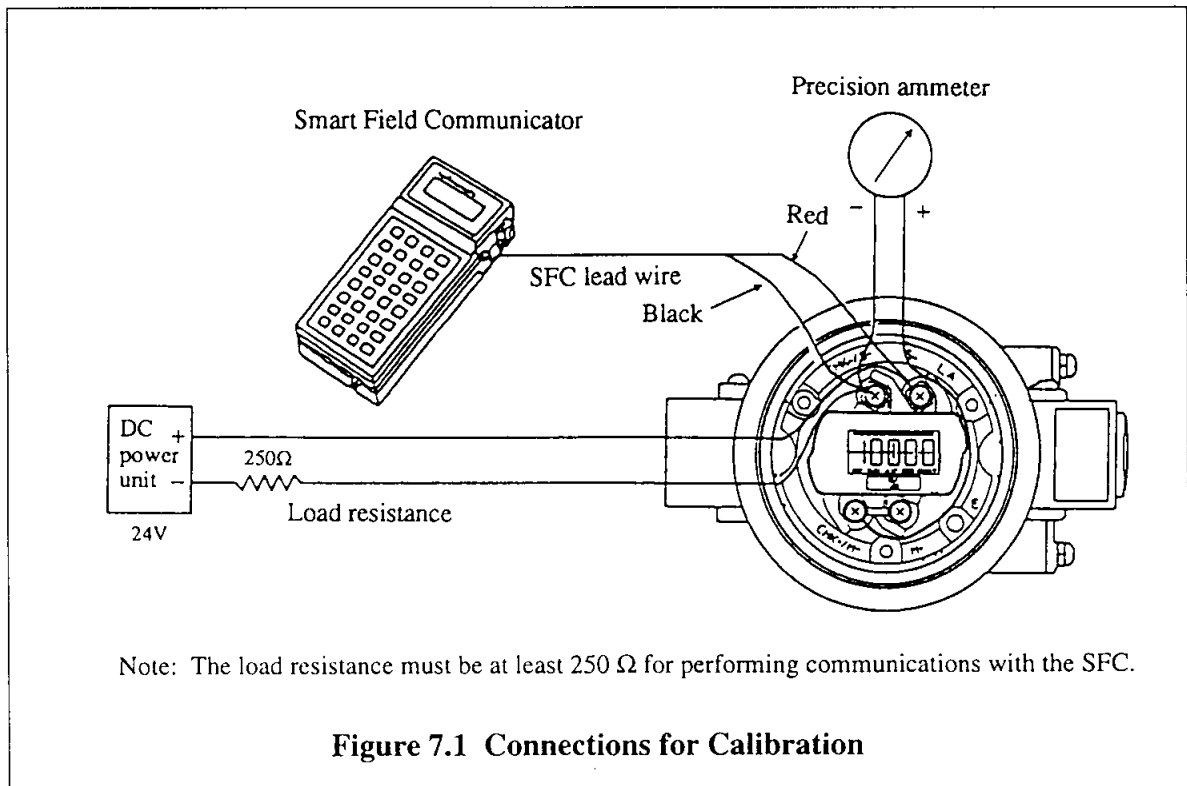

Check the configuration data by following the instructions in 6.1.3 through 6.1.5.

7.2 Calibrating Output Signals

7.2.1 Adjusting Output Signal 0%

(1) Key in 0%.

INPUT
OUT-PUT

O	U	T	P	U	T	T	1	2	3	4	5	6	7
W	O	R	K	I	N	G	.	.	.				

O	U	T	P	U	T	T	1	2	3	4	5	6	7
0	.	0	0	%									

The current output signal (%) is displayed.

ACT PR
0

O	U	T	P	U	T	T	1	2	3	4	5	6	7
0	%												

Key in "0".

NON-VO
ENTER
(Yes)

O	U	T	P	U	T	T	1	2	3	4	5	6	7
W	O	R	K	I	N	G	.	.	.				

O	U	T	P	U	T	T	1	2	3	4	5	6	7
0	.	0	0	%									#

The transmitter becomes a constant current source of 0% output.

INPUT
OUT-PUT

O	U	T	P	U	T	T	1	2	3	4	5	6	7
W	O	R	K	I	N	G	.	.	.				

O	U	T	P	U	T	T	1	2	3	4	5	6	7
0	.	0	0	%									#

The current output is 0%.

RESET
COR-RECT

D	S	T	J	T	1	2	3	4	5	6	7		
C	O	R	R	E	C	T	D	A	C	Z	E	R	#

Press the "CORRECT" key and the 0% output value can be corrected.

(2) When the value indicated by the meter is lower than 4 mA or 1V (when the resistance for voltage conversion is 250), make an adjustment by the following procedure.

H
▲
NEXT

D	S	T	J	T	1	2	3	4	5	6	7		
W	O	R	K	I	N	G	.	.	.				

Increase the output gradually.

D	S	T	J	T	1	2	3	4	5	6	7	
I	N	C	R	E	A	S	E	D	4	m	A	#

- (3) When the value indicated by the meter is higher than 4 mA or 1V, make an adjustment by the following procedure.



D	S	T	J				T	1	2	3	4	5	6	7
	W	O	R	K	I	N	G	.	.	.				

Decrease the output gradually.

D	S	T	J				T	1	2	3	4	5	6	7
	D	E	C	R	E	A	S	E	D		4	m	A	#

7.2.2 Adjusting Output Signal 100%

- (1) Key in 100%.

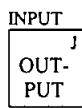

O	U	T	P	U	T			T	1	2	3	4	5	6	7
	W	O	R	K	I	N	G	.	.	.					#

The current output signal (0%) is displayed.

O	U	T	P	U	T			T	1	2	3	4	5	6	7
	0	.	0	0			%								#



O	U	T	P	U	T			T	1	2	3	4	5	6	7
	1	-					%								

Key in "100".

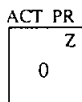

O	U	T	P	U	T			T	1	2	3	4	5	6	7
	1	0	-				%								

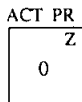

O	U	T	P	U	T			T	1	2	3	4	5	6	7
	1	0	0	-			%								

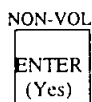

O	U	T	P	U	T			T	1	2	3	4	5	6	7
	W	O	R	K	I	N	G	.	.	.					

O	U	T	P	U	T			T	1	2	3	4	5	6	7
	1	0	0	.	0	0	%								#

The transmitter becomes a constant current source of 100% output.

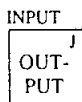

O	U	T	P	U	T			T	1	2	3	4	5	6	7
	W	O	R	K	I	N	G	.	.	.					

O	U	T	P	U	T			T	1	2	3	4	5	6	7
	1	0	0	.	0	0	%								#



D	S	T	J				T	1	2	3	4	5	6	7
	C	O	R	R	E	C	T	D	A	C	S	P	A	#

Press the "CORRECT" key and the 100% output value can be corrected.

- (2) When the value indicated by the meter is lower than 20 mA or 5 V (when the resistance for voltage conversion is 250 Ω), make an adjustment by the following procedure.



D	S	T	J				T	1	2	3	4	5	6	7
	W	O	R	K	I	N	G	.	.	.				

Increase the output gradually.

D	S	T	J				T	1	2	3	4	5	6	7
	I	N	C	R	E	A	S	E	D	2	0	m	A	#

- (3) When the value indicated by the meter is higher than 20 mA or 5 V, make an adjustment by the following procedure.



D	S	T	J				T	1	2	3	4	5	6	7
	W	O	R	K	I	N	G	.	.	.				

Decrease the output gradually.

D	S	T	J				T	1	2	3	4	5	6	7
	D	E	C	R	E	A	S	E	D	2	0	m	A	#

- (4) Saving data to the non-volatile memory (NVM) of the transmitter

After adjusting the output signals of 0% and 100%, save the data to the non-volatile memory of the transmitter by the following procedure.

The data in the work memory of the transmitter can be saved with high priority. The data will not be lost even if the transmitter is turned off. When any value in the work memory is changed, ST 3000 automatically saves data from the work memory to the NVM in about 30 seconds, even without this operation.



							S	H	I	F	T	-		

NON-VOL



D	S	T	J				T	1	2	3	4	5	6	7
	W	O	R	K	I	N	G	.	.	.				

Data is saved to the NVM. This operation takes about 8 seconds.

D	S	T	J				T	1	2	3	4	5	6	7		
	D	A	T	A		N	O	N	V	O	L	A	T	I	L	#

The operation has ended.

(5) Releasing the constant current source mode

INPUT J	O	U	T	P	U	T	T	1	2	3	4	5	6	7
O U T P U T	W	O	R	K	I	N	G	.	.	.				

O	U	T	P	U	T	T	1	2	3	4	5	6	7
0	.	0	0			%							#

The current output level is displayed.

CLR (No)	O	U	T	P	U	T	T	1	2	3	4	5	6	7
C L R	W	O	R	K	I	N	G	.	.	.				

The constant current source mode is released.

D	S	T	J			T	1	2	3	4	5	6	7
R	E	A	D	Y	.	.	.						

The releasing has ended.

(Note 7.2) The “#” mark disappears, indicating that the constant current source mode has been released.

7.3 Calibration Range

Next, calibrate the zero point and the span.

7.3.1 Calibrating the Low Limit (LRV)

In order to calibrate the low limit (LRV) of the range, apply the reference input pressure of the LRV to the transmitter. Then, correct the LRV using the SFC.

If the LRV and the reference input pressure are not the same, set the LRV to the reference input pressure.

(Note) Be sure to start with the LRV even if the operations are reversed.

E LRV 0%	L	R	V			T	1	2	3	4	5	6	7
L R V	2	0				k	P	a					

The LRV in the memory of the transmitter is displayed.

RESET K COR- RECT	L	R	V			T	1	2	3	4	5	6	7
R E S E T		C	O	R	R	E	C	T	L	R	V	?	

The SFC asks whether to match the LRV to the reference input pressure.

NON-VOL ENTER (Yes)	L	R	V			T	1	2	3	4	5	6	7
E N T E R	W	O	R	K	I	N	G	.	.	.			

Press the “ENTER” key, and the LRV will be corrected by the reference input pressure. (Zero point calibration)

L	R	V				T	1	2	3	4	5	6	7	
	L	R	V			C	O	R	R	E	C	T	E	D

7.3.2 Calibrating the High Limit (URV)

In order to calibrate the high limit (URV) of the range, apply the reference input pressure of the URV to the transmitter. Then, correct the URV using the SFC.

If the URV and the reference input pressure are not the same, set the URV to the reference input pressure.

F
URV
100%

U	R	V					T	1	2	3	4	5	6	7
	1	0	0				k	P	a					

The URV in the memory of the transmitter is displayed.

RESET
K
COR-
RECT

U	R	V					T	1	2	3	4	5	6	7
		C	O	R	R	E	C	T	U	R	V	?		

The SFC asks whether to match the URV to the reference input pressure.

NON-VOL
ENTER
(Yes)

U	R	V					T	1	2	3	4	5	6	7
		W	O	R	K	I	N	G	.	.	.			

Press the "ENTER" key, and the URV will be corrected by the reference input pressure. (span calibration)

U	R	V					T	1	2	3	4	5	6	7	
		U	R	V			C	O	R	R	E	C	T	E	D

7.3.3 Saving Calibration Data

After zero and span calibration, save the calibration data to the non-volatile memory by the following procedure.

Note) Save the data to the non-volatile memory by referring to 7.2.2 (4).

SHIFT
^

							S	H	I	F	T	-	-				

NON-VOL
ENTER
(Yes)

D	S	T	J				T	1	2	3	4	5	6	7
		W	O	R	K	I	N	G	.	.	.			

Data is saved to the NVM. This operation takes about 8 seconds.

D	S	T	J				T	1	2	3	4	5	6	7			
		D	A	T	A		N	O	N	V	O	L	A	T	I	L	E

The operation has ended.

7.4 Erasing Calibration Data

7.4.1 Erasing Calibration Data

When the transmitter is given a wrong calibration, the calibrated values and set values can be restored to the initial values by the following procedure.

SHIFT [^]						S	H	I	F	T	-						

RESET ^K COR- RECT	D	S	T	J				T	1	2	3	4	5	6	7
	R	E	S	E	T		C	O	R	R	E	C	T	S	?

The SFC asks whether to restore the calibrated values and set values to the initial values.

NON-VOL ENTER (Yes)	D	S	T	J				T	1	2	3	4	5	6	7
		C	O	R	R	E	C	T	S		R	E	S	E	T

The values were restored to the initial values.

7.4.2 Erasing the “#” Mark

After restoring the calibrated values and the set values to the initial values, erase the “#” mark by the following procedure.

Perform calibration by inputting a real pressure by referring to “7.3 Calibrating Range”.

Note : When calibrating, turn off the temperature compensation.

(1) Set the LRV using a real pressure.

LRV ^E %	L	R	V					T	1	2	3	4	5	6	7
	0	.	0	0	0	0		k	P	a					

The SFC displays the current LRV.

TOTAL SET ^G	L	R	V					T	1	2	3	4	5	6	7
				S	E	T		L	R	V		?			

The SFC asks whether to set the LRV at the current pressure.

NON-VOL ENTER (Yes)	L	R	V					T	1	2	3	4	5	6	7
		W	O	R	K	I	N	G	.	.	.				

Press the “ENTER” key, and the data will be loaded into the memories of the transmitter and the SFC.

L	R	V						T	1	2	3	4	5	6	7
0	.	0						k	P	a					

After the data is loaded to the memories, the new LRV is displayed.

(2) Correct the LRV using a real pressure.

LRV ^E %	L	R	V					T	1	2	3	4	5	6	7
	0	.	0					k	P	a					

The LRV in the memory of the transmitter is displayed.

RESET

K
COR-
RECT

L	R	V				T	1	2	3	4	5	6	7	
			C	O	R	R	E	C	T		L	R	V	?

The SFC asks whether to match the LRV to the reference input pressure.

ENTER
(Yes)

L	R	V				T	1	2	3	4	5	6	7	
			W	O	R	K	I	N	G	.	.	.		

Press the "ENTER" key, and the LRV will be corrected by the reference input pressure.

L	R	V				T	1	2	3	4	5	6	7		
			L	R	V		C	O	R	R	E	C	T	E	D

The LRV has been corrected.

SHIFT

					S	H	I	F	T	-				

NON-VOL

ENTER
(Yes)

D	S	T	J			T	1	2	3	4	5	6	7	
			W	O	R	K	I	N	G	.	.	.		

Data is saved to the NVM. This operation takes about 8 seconds.

D	S	T	J			T	1	2	3	4	5	6	7					
			D	A	T	A		N	O	N	V	O	L	A	T	I	L	E

The data has been saved to the NVM.

(3) Turn off the transmitter.

(4) Turn on the transmitter.

DE READ

A
ID

D	S	T	J			T	1	2	3	4	5	6	7	
			W	O	R	K	I	N	G	.	.	.		

D	S	T	J			T	A	G		N	O						
			L	I	N		D	P		T	1	2	3	4	5	6	7

F/S DIR

U
STAT

D	S	T	J			T	1	2	3	4	5	6	7	
			W	O	R	K	I	N	G	.	.	.		

D	S	T	J			T	1	2	3	4	5	6	7				
			S	T	A	T	U	S		C	H	E	C	K	=	O	K

The "#" mark has disappeared.

9. Maintenance and Inspection

9.1 Maintaining the Meter Body

The meter body does not need any special routine maintenance/inspection. When the flange is dismounted for maintenance, wash the diaphragm using a soft brush and solvent. Work carefully without deforming or damaging the diaphragm.

9.2 Insulation Resistance Test and Dielectric Strength Test

As a general rule, neither insulation resistance nor dielectric strength test should be performed. These tests can destroy the built-in varistors used for absorbing surge voltage. When the tests must be performed, follow the following procedure.

- (1) Disconnect the external wiring from the transmitter.
- (2) Create a short-circuit between the transmission line +, - connection terminals and the external ammeter + connection terminal.
- (3) Perform the tests between the short-circuited section described in step (2) and the ground terminal.
- (4) The voltage to be applied and the criteria are given below. To prevent damage, do not apply a higher voltage.

Insulation resistance test: 2×10^7 or over, 25 VDC (when $25^\circ\text{C} \pm 5^\circ\text{C}$, not over 60%R.H.)

Dielectric strength test: 50 VAC for 1 minute, set current 2 mA

If a higher voltage test must be performed (Insulation resistance: 500 VDC; dielectric strength: 500 VAC for 1 minute or 600 VAC for 1 second), separate the connection plate and the case.

10. Self-diagnosis

The ST3000 Ace Smart Transmitter has a self-diagnosis function. The communication, loop and operation states of the transmitter can be checked via this self-diagnosis function by using the SFC.

10.1 Contents of Diagnosis

The contents of the diagnosis can be classified into the following four types.

10.1.1 Non-critical Errors

(1) Description

- ① The function requested from the SFC is executed.
- ② The tag No. of the transmitter is displayed in the upper line of the LCD screen and an error message is displayed in the lower line. At the same time, # is displayed in the 16th column of the lower line.

(2) Messages

Display	Description
• CORRECT RESET #	Re-calibration is necessary.
• EXCESS ZERO CORR #	The amount of zero calibration is too large.
• EXCESS SPAN CORR #	The amount of span calibration is too large.
• M.B. OVERLOAD or METER BODY FAULT #	The input pressure exceeds (allowable range × 2) or the meter body of the transmitter has a fault.
• NO DAC TEMP COM #	The temperature compensation data in the electronics module has been lost.
• SENSOR OVER TEMP #	The sensor temperature is too high.
• STATUS UNKNOWN #	The current status is unknown.

10.1.2 Critical Errors

(1) Description

- ① Even if the status of the information from the transmitter is critical, the ID, OUTPUT and STATUS functions operate.
- ② A critical status message is displayed for 3 seconds and, then, PRESS STATUS is displayed.
- ③ The tag No. of the transmitter is displayed in the upper line of the LCD screen and an error message is displayed in the lower line.

(2) Messages

Display	Description
• CHAR PROM FAULT	The sensor characterization PROM has a fault.
• ELECTRONIC FAULT	The electronic system has a fault.
• METER BODY FAULT	The meter body of the transmitter has a fault.
SUSPECT INPUT	Input error

10.1.3 Communication Errors

(1) Description

- ① A communication request function is not executed.
- ② The contents of the communication error are displayed entirely every 2 seconds.
- ③ NO XMTR RESPONSE is displayed in the upper line of the LCD screen and an error message is displayed in the lower line.

(2) Messages

Display	Description
• FAILED COMM CHK	Communication is not possible.
• HI RES/LOW VOLT	The load resistance of the loop is too large./ The supply voltage is too low.
• ILLEGAL RESPONSE	The SFC and the transmitter are not communicating normally.
• INVALID REQUEST	A function that cannot be executed has been requested.
• LOW LOOP RES	The resistance value of the loop is too small.
• NO XMTR RESPONSE	The transmitter gives no response.

10.1.4 Operational Errors

(1) Description

- ① The requested function is not executed because the error is attributable to a mistake in SFC operation.
- ② Nothing is displayed in the upper line of the LCD screen and an error message is displayed in the lower line.

(2) Messages

Display	Description
• ENTRY > SEN RANGE	The range that was entered exceeds (high limit of range × 1.5).
• EXCESSIVE OUTPUT	The set value for constant current exceeds the allowable range.
• KEY NOT ALLOWED ! > RANGE	Wrong key operation The result of arithmetic operations by the SFC exceeds the display range.

10.2 Method of Diagnosis

Connect the SFC and check the operational status of the transmitter according to the following operation.

F/S DIR

U
STAT

D	S	T	J				T	1	2	3	4	5	6	7
	W	O	R	K	I	N	G	.	.	.				

The fault state of the meter body is not displayed in detail. Judge this from the state of the diaphragm and the sensor.

① When normal

D	S	T	J				T	1	2	3	4	5	6	7
S	T	A	T	U	S		C	H	E	C	=	O	K	

The transmitter and SFC are operating normally.

or

② When abnormal

D	S	T	J				T	1	2	3	4	5	6	7	
S	E	N	S	O	R		O	V	E	R	T	E	M	P	#

The current status of the transmitter is displayed. The meanings of the messages are explained in "Display Messages".

then

D	S	T	J				T	1	2	3	4	5	6	7	
S	T	A	T	U	S		R	E	C	E	I	V	E	D	.

This indicates the end of a message statement. Press the "STAT" key again, and a new message statement will be displayed or the current message statement will be displayed again. When more than one fault exist, each fault message will be displayed for 5 seconds.

10.3 Display Messages

The following three messages interrupt the display of the SFC.

Message	Description	Action																														
<table border="1"> <tr> <td>D</td><td>S</td><td>T</td><td>J</td><td></td><td></td><td></td><td>T</td><td>1</td><td>2</td><td>3</td><td>4</td><td>5</td><td>6</td><td>7</td> </tr> <tr> <td>C</td><td>R</td><td>I</td><td>T</td><td>I</td><td>C</td><td>A</td><td>L</td><td>S</td><td>T</td><td>A</td><td>T</td><td>U</td><td>S</td><td></td> </tr> </table>	D	S	T	J				T	1	2	3	4	5	6	7	C	R	I	T	I	C	A	L	S	T	A	T	U	S		Refer to the message table.	Press the "STAT" key and refer to the message table.
D	S	T	J				T	1	2	3	4	5	6	7																		
C	R	I	T	I	C	A	L	S	T	A	T	U	S																			
<table border="1"> <tr> <td></td><td></td><td></td><td></td><td></td><td></td><td></td><td>:</td><td></td><td></td><td></td><td></td><td></td><td></td><td></td> </tr> </table>								:								A colon indicates that the SFC has a low battery level.	Charge the SFC.															
							:																									
<table border="1"> <tr> <td></td><td></td><td></td><td></td><td></td><td></td><td></td><td></td><td></td><td></td><td></td><td></td><td></td><td></td><td>#</td> </tr> </table>															#	This indicates a non-critical status.	Press the "STAT" key and refer to the message table. After eliminating the cause of the problem, make sure that the "#" mark has disappeared by pressing the "STAT" key.															
														#																		

10.4 Messages and Required Actions

(The messages are listed in the table in alphabetic order.)

No.	Message	Description	Action
1	CHAR PROM FAULT (Critical fault)	The PROM is not functioning correctly.	Replace the PROM. When replacing the PROM, check its serial No. by pressing the "SHIFT" key and the "1" key in that order. Replace it with a PROM with the same specifications. (When replacing the meter body, use a PROM with the same number.)
2	CORRECT DAC SPAN	The output circuit 20 mA is being adjusted.	Correct the output signals.
3	CORRECT DAC ZERO	The output circuit 4 mA is being adjusted.	Correct the output signals.
4	CORRECT LRV ?	Is the 0% range input value correct?	Refer to the input value.
5	CORRECT URV ?	Is the 100% range input value correct?	Refer to the input value.
6	CORRECT RESET #	Re-calibration is necessary to maintain accuracy.	Correct the LRV and URV.
7	DATA NON - VOLATILE	Data has been stored in the non-volatile memory.	Check the differential pressure input value.
8	DATA RESTORED	Saved data has been restored to the transmitter.	
9	DATA SAVED	Data has been saved from the transmitter to the SFC.	
10	DOWN SCALE	The burnout direction at the time of a critical fault is downward.	
11	ENTRY > SEN RANGE	A value exceeding (high limit of transmitter range \times 1.5) has been entered.	Check the numerical value by pressing the "CLR" key and input a value again.
12	EXCESS SPAN CORR #	The amount of span calibration is too large.	Check the input pressure to see if it matches the corrected value. Correct the URV.
13	EXCESS ZERO CORR #	The amount of zero calibration is too large.	Check the input pressure to see if it matches the corrected value. Correct the LRV again.
14	EXCESSIVE OUTPUT	The requested output value exceeds the output range (between -1.25% and 105%) in the constant current source mode.	Check the numerical value by pressing the "CLR" key and input a valid value.
15	FAILED COMM CHK	Communications have failed. The SFC has an electronic fault or is not connected correctly.	1. Check the polarity. 2. Press the "STAT" key. If the COMM ERROR display does not disappear, replace the SFC. For other messages, refer to their descriptions.

No.	Message	Description	Action
16	HI RES/LOW VOLT	The loop resistance is too large (including wire breakage) or the impressed voltage is too low.	
17	ILLEGAL RESPONSE	Communications are not taking place normally between the SFC and the transmitter.	Check the polarity, wiring and power.
18	IN OUTPUT MODE #	The transmitter is functioning as a constant current source.	In order to release the constant current source mode, press the "OUTPUT" key and the "CLR" key in that order.
19	INPUT ZEROED	Calibration in the sensor balanced state (atmospheric pressure) has been completed.	
20	INVALID DATABASE	When the transmitter was turned on, its database was invalid.	1. Perform communications again. 2. Check the database, calibrate the transmitter again and load data to the non-volatile memory.
21	INVALID REQUEST	A function that cannot be executed has been requested.	Check the SFC operation procedures.
22	KEY NOT ALLOWED !	A wrong key was pressed or the sequence of key operations was wrong.	Press the "CLR" key and perform the key operation again.
23	LINEAR	The output characteristic is linear.	
24	LOOP IN MANUAL?	Is the loop for communications in the manual mode?	Select the manual mode.
25	LOW LOOP RES	The resistance value on the communication loop is too small.	Check the resistance value.
26	LRV CORRECTED	Calibration of the 0% range has been completed.	
27	M.B. OVERLOAD OR METER BODY FAULT	The input pressure exceeds (allowable range \times 2).	Check the PV value. Replace the transmitter by a model with a larger range if necessary. Since the meter body of the transmitter may have been damaged, check the performance.
28	MDU/DACCOMPFAULT	MDU/DAC fault	Replace the electronics module.
29	NON-B/O	The burnout for critical faults has no direction.	

No.	Message	Description	Action
30	NO XMTR RESPONSE	The transmitter gives no response. The transmitter may have a fault or the loop may not be correct.	1. Perform communications again. 2. Press the "STAT" key and perform the actions correctly. 3. Check the transmission line and the connection of the SFC.
31	NO DAC TEMP COM #	The temperature compensation data on the electronics module has been lost.	Replace the electronics module.
32	NOT SUPPORT	Wrong key operation. The key operation is not supported.	
33	NVM FAULT	Non-volatile memory fault	Replace the electronics module.
34	PAC FAULT	PAC fault	Replace the electronics module.
35	PRESS STATUS	Press the self-diagnosis key (STAT).	
36	PRINTER FAIL ! #	The printer fails to operate.	
37	RAM FAULT	RAM fault	Replace the electronics module.
38	READY ...	Ready status	
39	RESET CORRECT ?	Do you want to erase the correction data?	
40	RESTORE DATA ?	Do you want to restore saved data to the transmitter?	
41	ROM FAULT	ROM fault	Replace the electronics module.
42	SAVE DATA ?	Do you want to save transmitter data?	
43	SENSOR OVER TEMP #	The sensor temperature is too high. This will lower the accuracy and shorten the service life.	Change the mounting in order to lower the temperature.
44	SET LRV?	Do you want to set the 0% range at the present input pressure?	
45	SET URV?	Do you want to set the 100% range at the present input pressure?	

No.	Message	Description	Action
46	SFC FAULT	The SFC does not operate correctly.	Perform communications again. If the status does not change, replace the SFC.
47	SHIFT	The white characters on each key of the SFC will be selected.	
48	STATUS CHECK = OK	No error	
49	STATUS RECEIVED	Self-diagnosis of the transmitter has been completed.	
50	STATUS UNKNOWN #	The status is unknown.	
51	SQUARE ROOT	The output characteristic is given square-root processing.	
52	SUSPECT INPUT	The input data may be wrong. This trouble may be attributable to the process, the meter body of the transmitter, or the electronics. Also, this message is displayed when the connector from the meter body is not mounted correctly on the electronics.	Press the "STAT" key. If no message is displayed, the possibility that the trouble is related to the meter body of the transmitter is high. Check the meter body.
53	UP SCALE	The burnout for critical fault is upward.	
54	URV CORRECTED	100% range correction has been completed.	
55	WORKING ...	Operating status	
56	ZERO INPUT?	Is the sensor balanced (atmospheric pressure)?	Check to see if it is in the atmospheric state.
57	> RANGE	The result of computing exceeds the display length.	Press the "CLR" key and start again.
58	:	The SFC has a low battery level.	Charge the SFC.
59	#	Non-critical fault	Press the "STAT" key. Refer to the message table. After eliminating the cause of the problem, make sure that the "#" mark has disappeared by pressing the "STAT" key.

11. Troubleshooting

If the transmitter fails to operate normally, locate the source of trouble according to the following procedure.

- (1) Check the following items by using the self-diagnosis function.
 - 1) Configuration data
 - 2) Transmitter operation
 - 3) Loop
- (2) If the trouble was located in step (1), take the necessary action by referring to Section 10 “Self-diagnosis”.

12. External Zero Point Adjustment (optional)

12.1 External zero point adjustment

Introduction:

Since this transmitter has an external zero point adjusting function, the zero point can be adjusted externally without using the S-SFC.

A transmitter with a digital meter will display “ZERO” in the display area.

Adjustment range:

An output corresponding to the current input can be set to any value within the range of -1.25% (3.8 mA) to +105% (20.8 mA).

Procedure:

Adjust the zero point externally using the following procedure:

- (1) Make sure that the required differential pressure is applied to the transmitter.
- (2)
 - Holding down the zero point adjust button using a regular screw driver, turn it in the desired direction (+ or -) until the output reaches the target value.
 - Output increase: Holding down the button, turn it in the plus (+) direction. A transmitter with a digital meter will display “UP ZERO” during adjustment.
 - Output decrease: Holding down the button, turn it in the minus (-) direction. A transmitter with a digital meter will display “ZERO DOWN” during adjustment.

Caution

Do not turn the adjust button excessively, as it may break.

- Zero point adjustment will be interrupted by communications from the S-SFC.
- The S-SFC can read set values and set states only when communicating during zero point adjustment.

Output adjustment quantity:

The output adjustment quantity changes according to how long the button is pressed down and turned, as shown below.

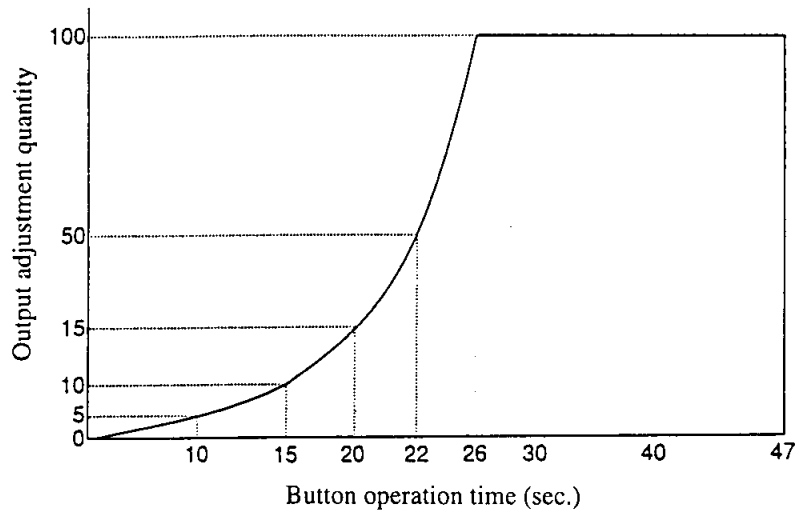

Relationship between output adjustment quantity and button operation time

- The adjustment quantity increases with turning time (refer to the above graph.)
- The speed of adjustment (increase/decrease) increases with turning time (refer to the above graph.)

Error diagnosis:

The transmitter will determine if the external zero point adjustment function is operating normally, and “ZERO” will blink on the indicator.

If adjustment continues for about 50 seconds, the transmitter will determine an error, and the value will be reset to the pre-adjustment value.

12.2 Influence due to Magnetic Fields

1. When a transmitter is installed in a strong magnetic field, the magnetic field will some have an effect and change the zero point, as with the magnet rod.
2. A magnetic field over 10 gauss may be generated near a motor or a pump. In such cases, install the transmitter at a distance of at least 1 to 2 m from the motor or pump.
The magnetic field will fall to 2 to 3 gauss at a distance of 1 to 2 m.
3. If it is suspected that a magnetic field exceeding 10 gauss is present, measure this with a gauss meter and move the transmitter further away, to a place where the field is below 10 gauss.

13. Indicator (optional)

13.1 Identification of indicator parts

The names of the indicator parts are shown below.

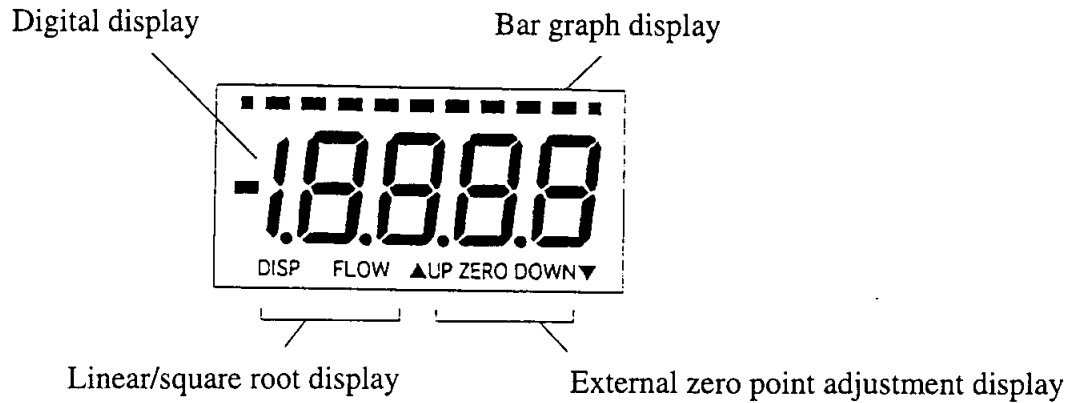

13.2 Digital display

The indicator digitally displays the transmitter output as a % value or in any engineering unit. The digital display is a 4.5 digit 7-segment LCD. Please note the following.

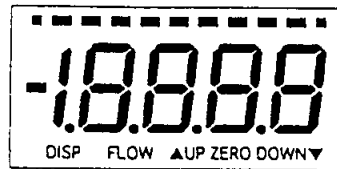

- If the current value exceeds the following range, the display limit value will blink.
 Current value < -19999
 Current value > 19999
- The indicator sometimes displays the following in the event of transmitter malfunction. In such cases, take the necessary action by referring to Item 13.7.

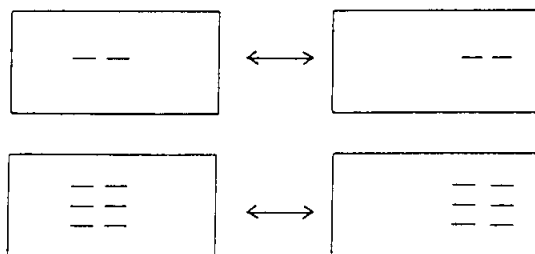

13.3 Analog bar graph display

The transmitter output is displayed in an 11-segment analog bar graph. The correspondence between the bar segment on/off states and the output values is shown below.

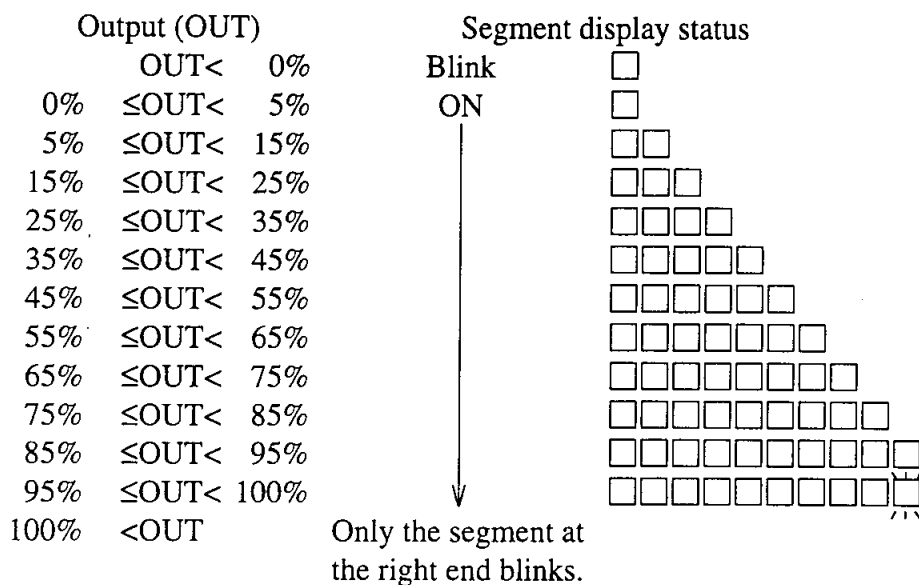

- In the constant current mode, the whole bar graph blinks.
- The bar graph and the digital display blink alternately.

13.4 Linear/square root extraction display

This function is used to determine whether the transmitter output value and the indicator display value are linear (differential pressure) or the result of square root extraction operation (flow rate).

The deciding criteria based on the display state are shown below.

Display	Output	Segment display status		Display	Name
		DISP	FLOW		
Linear (Differential pressure)	Linear (Differential pressure)	OFF	OFF	None	Linear
Square root extraction (Flow rate)	Linear (Differential pressure)	ON	ON	Disp flow	Display Flow Rate (Display Square Root Extraction)
Square root extraction (Flow rate)	Square root extraction (Flow rate)	OFF	ON	Flow	Flow Rate (Square Root Extraction)

13.5 External zero point adjustment display

A transmitter with the external zero point adjustment function displays the operational status. The deciding criteria based on the display status are shown below. A transmitter with this function maintains a “ZERO” display.

Adjustment status	Segment display			Display
	△UP	ZERO	▽DOWN	
Output increasing	ON	ON	OFF	△UP ZERO
Output decreasing	OFF	ON	ON	ZERO ▽DOWN
Error	OFF	Blink	OFF	ZERO

- In the event of an error, take the necessary action by referring to Item 6.6. For the adjustment procedure, refer to Item 3.11.

13.6 Self-diagnosis display on indicator

Turn on the power and check to see if the indicator is normal.

- The indicator will not light up if there is a wiring error.
- When the indicator has an abnormality, an “Error No.” corresponding to the abnormality will be displayed in the display unit.

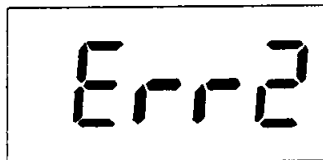

Self-diagnosis error (ROM error)

- If the transmitter itself has an abnormality, the messages explained in Item 3.10.2 will be displayed.

13.7 Self-diagnosis by indicator



Introduction:

If the indicator or the transmitter has an abnormality, the details will be displayed in the digital display unit of the indicator.

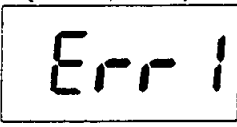
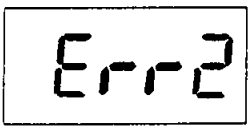
Self-diagnosis following power on

Message	Meaning	Action
 (Blink)	Digital indicator RAM failure	Contact the location shown on the reverse side.
 (Blink)	Digital indicator ROM failure	Contact the location shown on the reverse side.

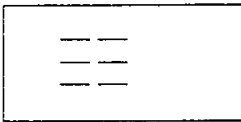
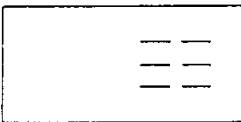
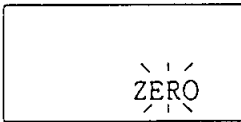
 Self-diagnosis during regular operation

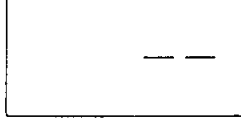
Message	Meaning	Action
 Alternating display 	Serious failure of transmitter	Contact the location shown on the reverse side.
 (Blink)	External zero point adjustment	Contact the location shown on the reverse side.
 Alternating display 	Transmitter or indicator failure	Contact the location shown on the reverse side.

13.8 Engineering Unit Label

Use the engineering unit label sheet (included) to indicate the display area on the engineering unit.

* If you specify an engineering unit at the time of ordering, the equipment will be shipped with the specified label already attached. Change the engineering unit label by the following procedure when necessary.

* Pointer labels for analogue bar graphs are provided on the engineering unit label sheet. Use them for monitoring in the field.

1. Select a unit label or a pointer label and remove it from the sheet.
2. Attach the label to the designated position as illustrated below.

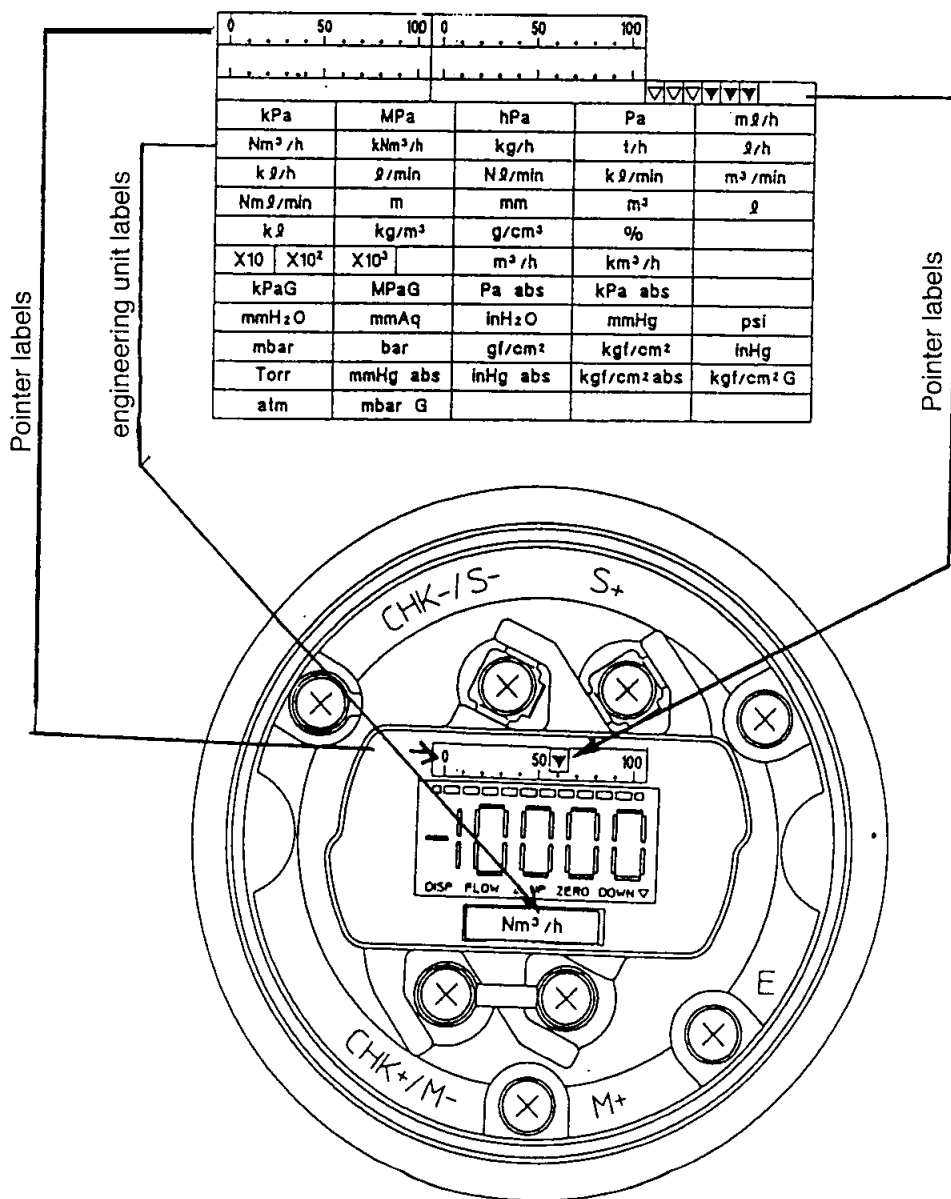

14. Direct Mounting (Patent pending)

14.1 Overview

Direct mounting is a simple kit (adaptor, tube clamp) designed to make it easy to install a remote seal transmitter on a tank for tank level measurements.

Direct mounting eliminates the need for a stanchion when installing the transmitter main unit. Achieving outstanding temperature characteristics is possible by selecting Yamatake Corporation's unique, fill-fluid temperature compensation function, which is standard for remote seal transmitters, and by careful positioning of the capillary tube.

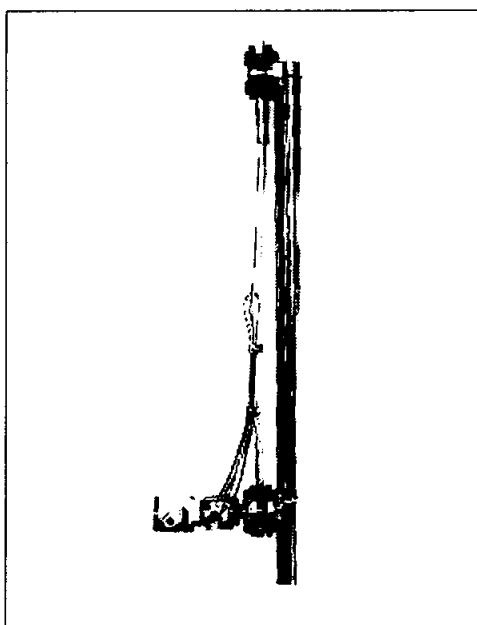

Figure 14.1 Example of Direct mounting Installation

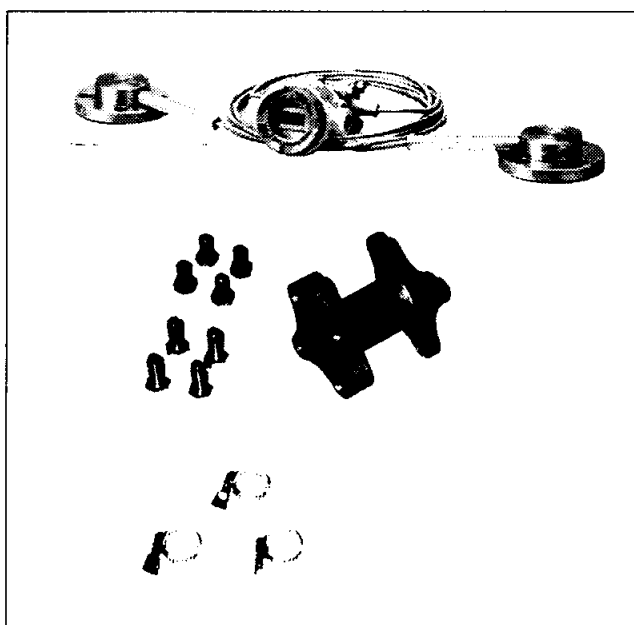

Figure 14.2 Remote Seal Transmitter and Direct mounting Installation Kit

14.2 Characteristics

- (1) Simple, easy-to-install
 - The adaptor lets you install the transmitter directly onto the exterior of any tank, eliminating the need for a 2B stanchion pipe. Direct mounting saves installation space and effort.
 - The capillary tube can be firmly fastened with tube clamps. Optimum capillary tube length can be obtained simply by measuring the distance between tank flanges.
- (2) Outstanding ambient temperature characteristics
 - Yamatake Corporation's fill-fluid temperature compensation function (patented) minimizes the influence of ambient temperature changes, and greatly improves zero shift. It reduces the effect of seasonal temperature changes by 1/5 to 1/10 over previous models.
 - Careful positioning of the capillary tube using the dedicated tube clamps can decrease zero shift due to differences in capillary temperature to half the previous level.

14.3 Specifications

Direct mounting installation kit specifications—remote seal transmitter accessory

For the remote seal transmitter specifications, refer to Appendix A.

— Direct mounting Installation Kit Specifications —

Material:

Adaptor: SCS13 (equivalent to SUS304)

Adaptor lock bolt: SUS304 (M8)

Tube clamp: Brass/nickel plated

Adaptor mounting:

Instrument side: Mounting with 4 adaptor lock bolts

Flange side: Mounting with 4 adaptor lock bolts

Tube clamp: Used for positioning and clamping the folded capillary tube.

Weight: About 600 g

14.4 Direct Mounting Transmitters

JTR926, JTR930, JTE929

JTR226, JTR229, JTR235

- A Direct mounting kit can be combined with the above remote seal differential pressure transmitters for general use only. It cannot be combined with high temperature, high temperature/vacuum, or high temperature/high vacuum models.

14.5 Installation procedure

14.5.1 Installation dimensions

Figure 14.3 is a view of an adaptor assembly mounted on a process, and Figure 14.4 is an external view of the adaptor. Figure 14.5 shows the installation kit adaptor length. For the other dimensions, refer to the external dimensions in “1. Overview.”

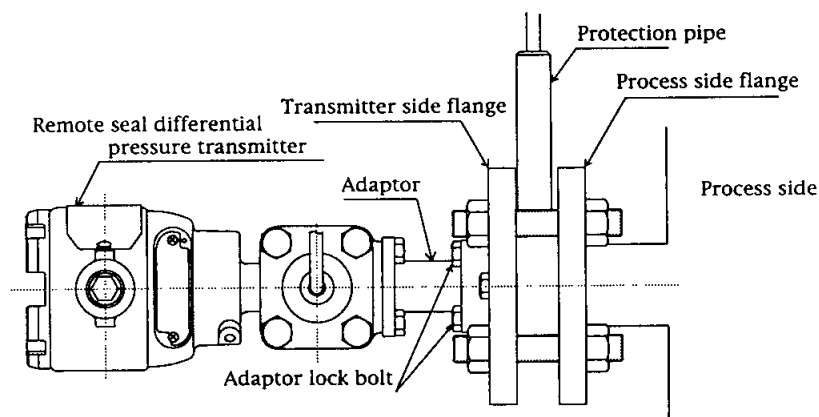

Figure 14.3 Adaptor Assembly (JTE)

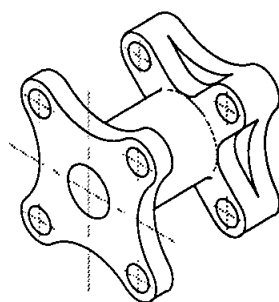

Figure 14.4 External View of Adaptor

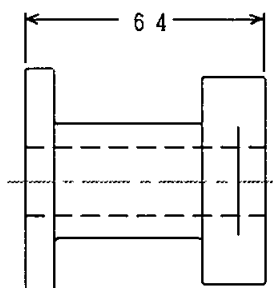

Figure 14.5 Adaptor Length

14.5.2 Installation location

Refer to A.5 Remarks about installation location.

14.5.3 Installation procedure

- (1) Fixing the adaptor to a transmitter

Make sure that the adaptor is fixed firmly to the transmitter main unit with four bolts.
(Refer to Figure 14.6.)

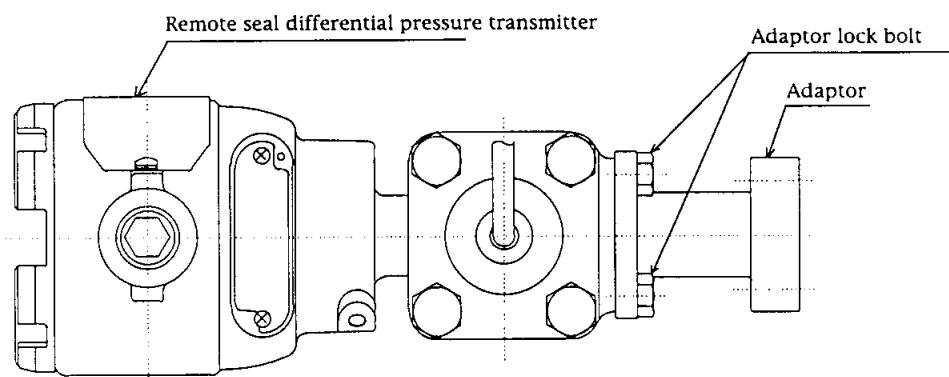

Figure 14.6 Mounting the adaptor on a transmitter

- (2) Mounting the transmitter flange on the process side flange

Mount the transmitter flange *1 on the process side flange before fastening it to the end of the adaptor that was fixed to the transmitter in step (1). (Refer to Figure 14.7.)

*1) The transmitter can be fixed to either high or low pressure side flange.

⚠ Caution

- When using a transmitter other than the JT□□29 model on an enclosed tank, be sure to mount the high pressure side connection flange (HP) on the upper side of the process.

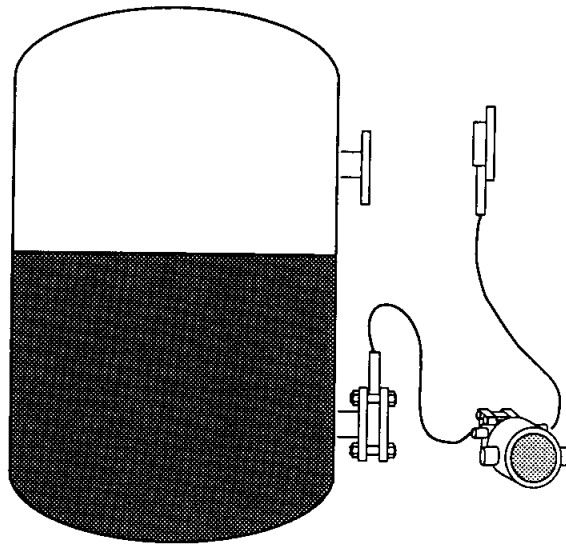

Figure 14.7 Installation on Process Side Flange No.1

- ① Installation on process flange
Install the transmitter flange on the process side flange using bolts and a gasket.

⚠ Caution

- When installing on a flange, tighten the bolts evenly and firmly to prevent leakage.

- ② Gasket selection for flange

The process user should obtain the flange gasket. Select a gasket with an appropriate shape that will not contact the diaphragm with the pressure receiving unit. Select a gasket made from a material appropriate for the fluid, operating pressure and temperature. The inner diameter is an important factor.

⚠ Caution

- Do not use a commercially available 3B gasket (inner diameter: 80 - 90 mm) for a 3B flush mount flange because the diaphragm diameter is 95 mm.
- Select a gasket that will not contact the diaphragm even in the event of collapse or deformation. A gasket made of a soft material may be inappropriate since such materials are prone to deformation by tightening.
- Align the gasket accurately. A gasket on a transmitter that is mounted in the vertical position may sometimes shift downward.
- When using a gasket with protective FEP film, mount the film in accordance with Item 5, and do not tighten excessively, as this may damage the protective film.

⚠ Caution

- When the transmitter main unit is flange-mounted on the upper side of a process, the inner pressure in the tank must be at atmospheric pressures or higher. If this condition cannot be met, install the transmitter on the lower side of the process.

- (3) Mounting a transmitter main unit with adaptor on the transmitter side flange
Ensure that the adaptor is firmly fitted to the transmitter: fasten the combination firmly to the transmitter side flange using 4 lock bolts (Refer to Figure 14.8.).

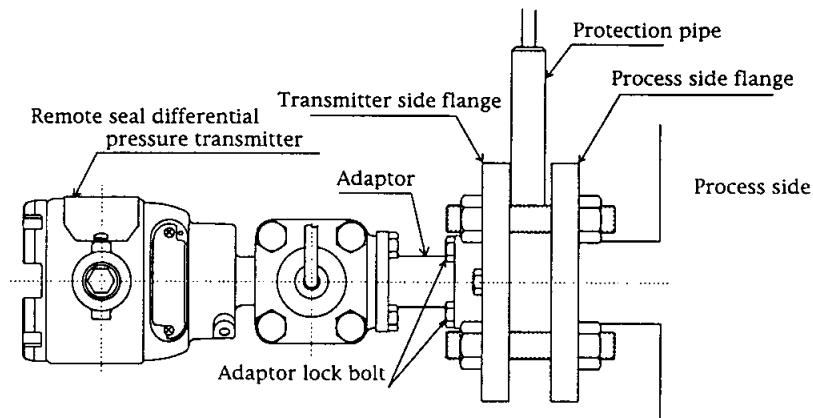

Figure 14.8 Installation on Transmitter Flange

- (4) Mounting the other transmitter side flange on the process flange
Mount the other transmitter side flange on the process side flange. (Refer to Figure 14.9 and (2) ① and ②.)

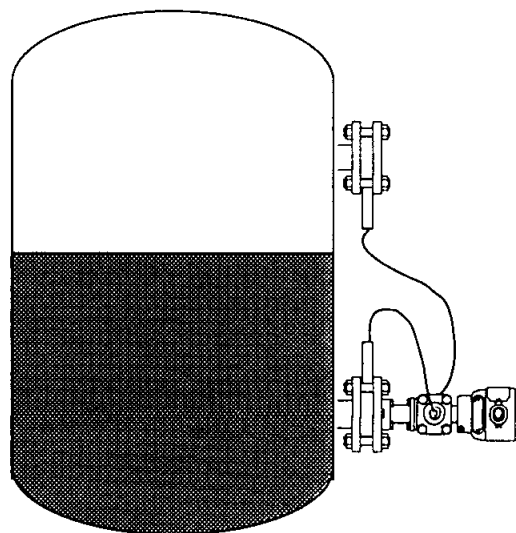

Figure 14.9 Installation on Process Side Flange No. 2

- (5) Positioning the capillary tube using tube clamps
Carefully position the capillary tube using tube clamps (accessory). Clamp tightly, but do not squeeze the capillary tube (Refer to Figure 14.10.).

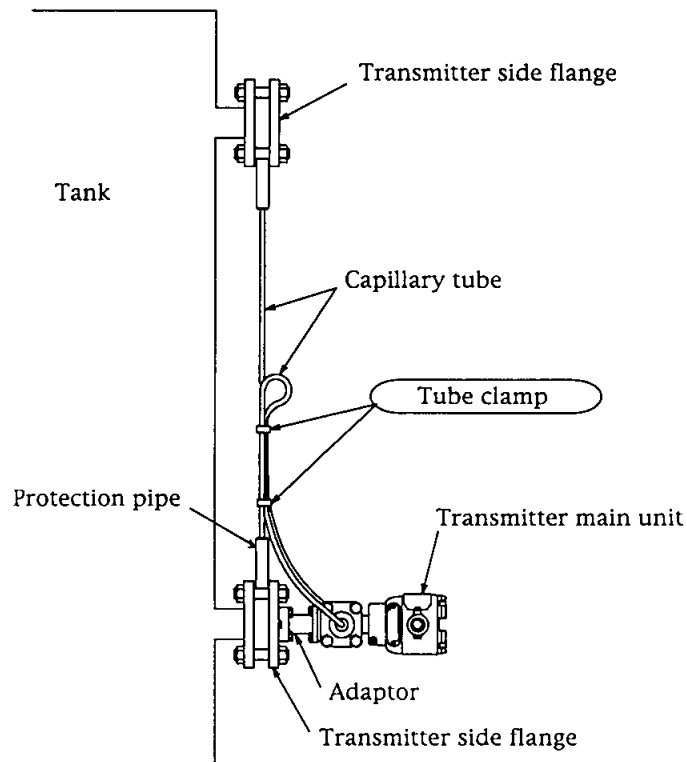

Figure 14.10 Capillary Tube Clamping

- ① Remarks about the capillary tube
- (1) Do not twist the capillary tube.
 - (2) When positioning the capillary tube, hold the flange part and turn it to form a large ring.
 - (3) Fold the capillary tube without applying more force than necessary.
The minimum bending diameter is about 5 cm. Do not bend and straighten the capillary tube repeatedly.
 - (4) Do not turn the capillary tube so that it twists at the flange connection.
 - (5) Space the capillary tube clamps equally to prevent vibration.

⚠ Caution

- To maintain the capillary tube in a position higher than the lower process side flange, the pressure in the tank must be at atmospheric pressure or higher. If this condition is not met, ensure that the capillary tube is lower than the lower process side flange.
- If the capillary tube is to lead out of the transmitter at a positive angle, specify an olefin-coated tube.
- If the capillary tube has no olefin coating, make sure that it leads out of the transmitter at a negative angle, so that its drain position is below the horizontal. If not, rain water may accumulate in the protection pipe at the drain position.

(6) Zero adjustment

After installing a transmitter on a tank, adjust the zero point.

For the zero point adjustment procedure, refer to Item 6.3 or Item 6.5.3(8).

(7) Setting the fill fluid temperature compensation function

Set the distance between the flanges using the S-SFC.

For the setting procedure, refer to item 6.5.3(9).

For information about the sealed liquid temperature compensation function, refer to Item 6.2.4.

The influence of ambient temperature changes can be minimized and the zero point shift can be greatly improved by setting this function.

(8) Miscellaneous

① Open tank

⚠ Caution

- The low pressure side flange of a transmitter that is not connected to the process should be fixed firmly in a location that is not exposed to large temperature changes or vibration. Damage to the seal diaphragm, drainage or dust will cause errors.

② Examples of installation under various conditions

Refer to Figure 14.11.

② Examples of installation under various conditions

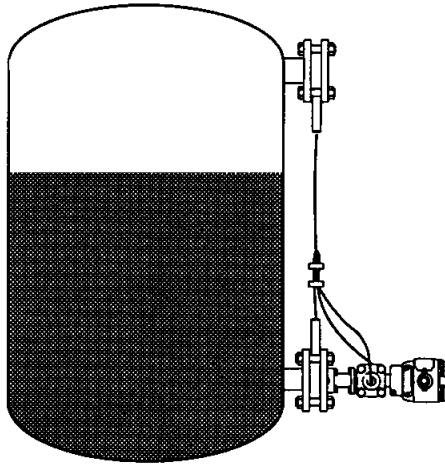

Pressure in tank : Atmospheric pressure, installation at the lower part of tank, olefin coated capillary tube

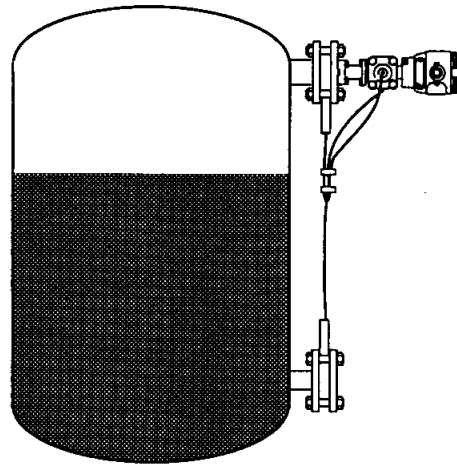

Pressure in tank : Atmospheric pressure, installation at the upper part of tank, olefin coated capillary tube

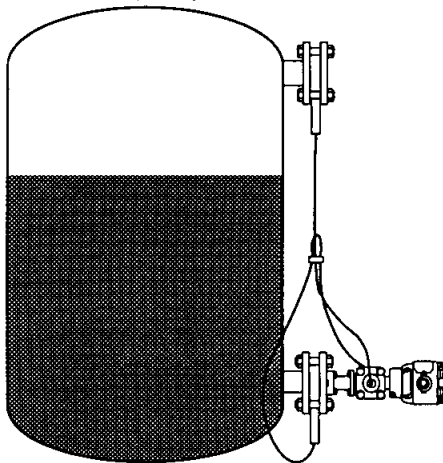

Pressure in tank : Atmospheric pressure, installation at the lower part of tank, non-olefin coated capillary tube

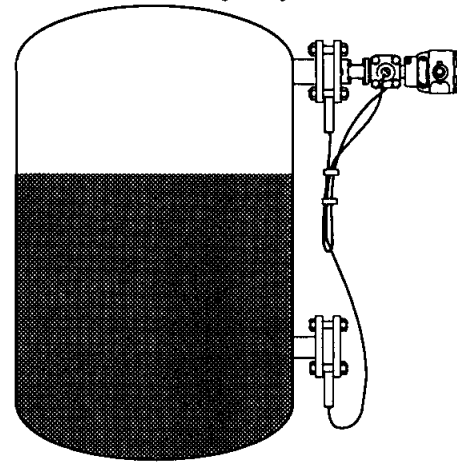

Pressure in tank : Atmospheric pressure, installation at the upper part of tank, non-olefin coated capillary tube

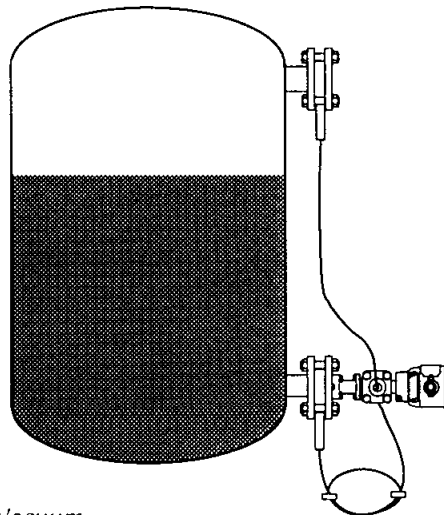

Pressure in tank : Vacuum (below atmospheric pressure)

Figure 14.11 Installation under Various Conditions

ST3000 Ace Smart Transmitter JTR Series of Remote-Sealed Type Differential Pressure Transmitters

JTR929A/JTR930A

General

The ST3000 Ace* Smart Transmitter is a microprocessor-based smart transmitter that features high performance and excellent stability. Capable of measuring gas, liquid, and vapor flow rates, and liquid levels, it transmits 4 to 20 mA dc analog and digital signals according to the measured differential pressure.

It can also execute two-way communications between the SFC (Smart Field Communicator), and, via DE protocol, with the TDCS3000 or 3000^x and a database, thus facilitating self-diagnosis, range resetting, and automatic zero adjustment.

Remote-sealed differential pressure transmitters are suitable for the measurement of differential pressures (flow rates, liquid levels, etc.) of process fluids that are highly corrosive, tend to condense, precipitate metal, etc.

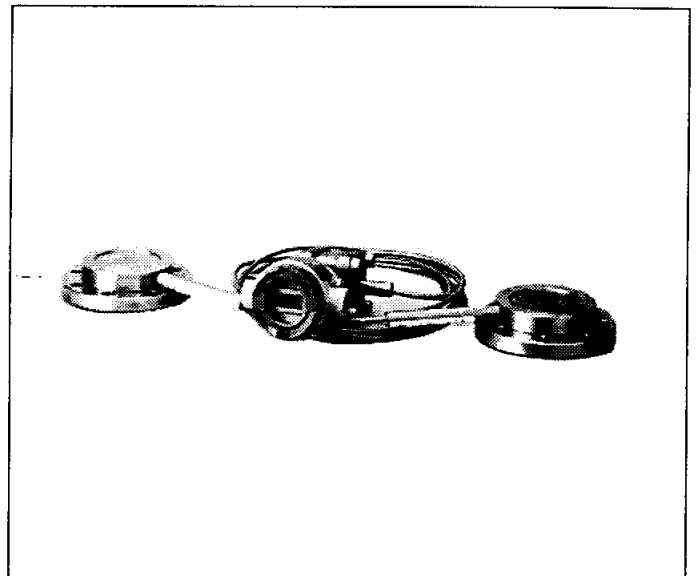

Features

- (1) Excellent stability and high performance
 - Long-term stability is proven in 500,000 installations worldwide.
 - Unique characterization and composite semiconductor sensors realize excellent temperature and static pressure characteristics.
- (2) A diverse lineup
 - A wide range of models is available to meet user requirements. They include general purpose, high-temperature service, high-temperature vacuum service, and high-temperature high-vacuum service. In addition, the working temperature range of general purpose models has been expanded to 180°C maximum to allow you greater freedom in instrumentation.
 - A wide variety of corrosion-resistant materials for wetted parts is also available.
 - These differential pressure transmitters can be mounted in various ways, including direct mounting on tanks without using 2B stanchion pipes.
- (3) Function to correct the temperature of the capillary section fill fluid:
 - Changes in the density of the fill fluid caused by temperature fluctuations are calculated, and the output is corrected accordingly. This function substantially reduces (to 1/5—1/10) the effect of seasonal fluctuations in temperature.
- (4) Multiprotocol communication
 - Either analog output (4 to 20 mA dc), analog FSK output (4 to 20 mA dc) or digital output (DE protocol) is possible.
 - Two-way communication using digital output facilitates self-diagnosis, range resetting, automatic zero adjustment, and other operations.
- (5) Full after-sales service program
 - From product delivery to replacement, we service all your needs. Our nationwide service network provides all the backup you require, including trial operation support and regular maintenance.

Applications

Petroleum/Petrochemical/Chemical

- For the measurement of liquid levels including corrosive fluids at high temperatures, and high temperatures under vacuum
- For the control of flow rates as used with tapless venturi tubes

Electric Power/City Gas/Other Utilities

- For measurement applications that require high degrees of stability and accuracy

Pulp and Paper

- For lines that need transmitters resistant to chemical liquids, corrosive fluids and the like

Iron and Steel/Nonferrous Metal/Ceramics

- For lines that require stable measurement under strictly controlled (temperature, humidity, etc.) conditions

Machinery/Shipbuilding

- For lines that require stable measurement under strictly controlled (temperature, humidity, vibration, etc.) conditions

Specifications

Measuring span/setting range/working pressure range:

See Table 1.

(-) sign before the height L setting.

Output/communication:

- Analog output (4 to 20 mA dc)
- Analog FSK output (4 to 20 mA dc)
(Frequency shift keying signal transmission system)
- Digital output (DE protocol)

Temperature ranges of wetted parts:

See Table 2.

Ambient temperature ranges:

See Table 2, except for explosion-proof models with digital indicators, which have to be used within the following ranges:

Supply voltage and load resistance:

10.8 to 45 V dc. A load resistance of 250 Ω or more is necessary between loops. (See Figure 1)

Models with digital indicators:

Normal operating conditions: -20 to 70°C

Operative limits: -30 to 80°C

JIS pressure-resistant special explosion-proof models: -20 to 60°C

JIS intrinsically safe explosion-proof models: -10 to 60°C

Sealing liquid:

Silicone oil for general purpose, high-temperature, high-temperature vacuum, and high-temperature high-vacuum models
Fluorine oil for oxygen and chlorine models
For specific gravity, see Table 2.

Ambient humidity range:

5 to 100% RH

Function to correct the temperature of the capillary section fill fluid: (Patent No.1978534)

Changes in the density of the fill fluid (ρ) caused by temperature fluctuations are calculated, and the output is corrected accordingly. This function substantially reduces the effect of seasonal fluctuations in temperature.

<How to set this function>

Set the inter-flange height L (m) according to the SFC. If the height L (m) is already known, let us know, so, this function can be set before shipment.

If the high pressure side (HP) of your transmitter is located under the tank, place a minus

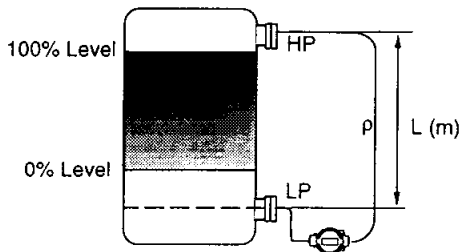

Stability against supply voltage change:

±0.005% FS/V

Lightning protection:

Peak value of voltage surge: 100 kV

Peak value of current surge: 1000 A

Dead time:

Approx. 0.4 sec

Damping time constant:

Selectable from 0 to 32 sec in ten stages

Waterproof/dustproof structure:

JIS C0920 watertight: NEMA3 and 4X

JIS F8001 class 2 watertight: IEC IP67

Explosion-proof structure:

JIS special explosion-proof models: (Exds II CT4)

JIS intrinsically safe models: (i3aG4)

	Measuring Span	Setting Range	Working Pressure Range
JTR929A	2.5~100kPa {250~10160mmH ₂ O}	-100~100kPa {-10160~10160mmH ₂ O}	Up to the smaller value of either setting range or flange rating (For negative pressures, see Figures 2 and 3.) (For flange rating, see "Max Working Pressure")
JTR930A	35~700kPa {0.35~7kgf/cm ² }	-100~700kPa {-1~7kgf/cm ² }	Up to the smaller value of either setting range or flange rating (For negative pressures, see Figures 2 and 3.) (For flange rating, see "Max Working Pressure")

Table 1 Measuring Span, Setting Range, and Working Pressure Range

		Temperature Range (°C) Note 1), Note 4)			
		General-purpose models	High-temp./high-temp. vacuum models	High-temp. high-vacuum models	Oxygen and chlorine models
Wetted parts section	Normal operating range	-40~180	-5~280 Note 5)	10~280 Note 5)	-10~120
	Operative limit range	-50~185	-10~310 Note 6)	-10~310 Note 6)	-40~125
Ambient temperature Note 2)	Normal operating range	-30~75	-5~55	10~55	-10~75
	Operative limit range	-50~80	-10~60	-10~60	-40~80
Specific gravity of fill liquid Note 3)		0.935	1.07	1.09	1.87

Table 2 Temperature Range of Wetted Parts Section and Ambient Temperature Range

- Note 1) See the working pressures and temperatures of the wetted parts section in Figure 2, Figure 3, and Figure 4.
 Note 2) Ambient temperatures of the transmitter itself
 Note 3) Approximate values at the temperature of 25°C
 Note 4) Note that if the operating temperature falls below the lower limit of the normal operating range, the response of the transmitter becomes slower.
 Note 5) When the wetted parts material is tantalum, the upper limit is 180°C.
 Note 6) When the wetted parts material is tantalum, the upper limit is 200°C.

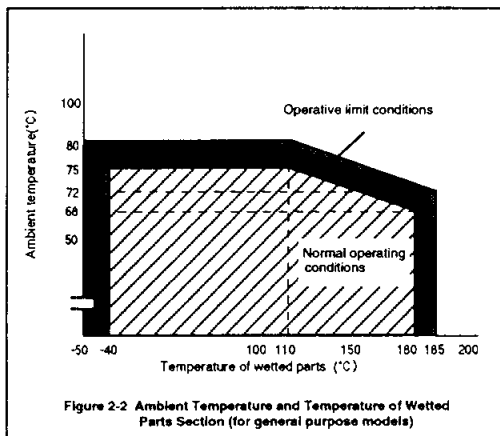
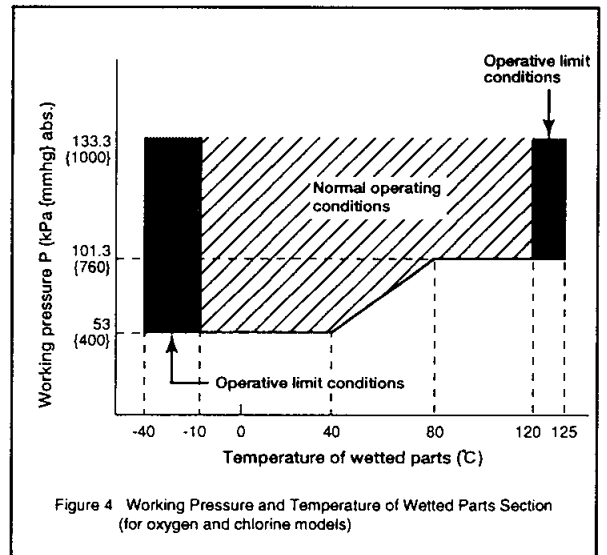
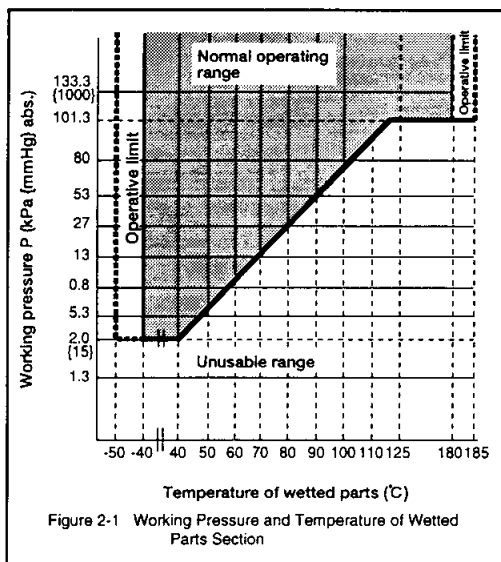
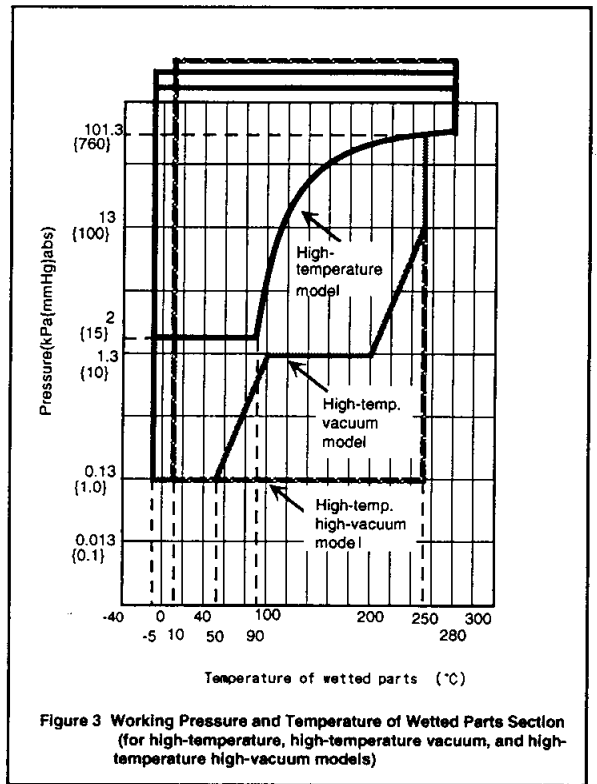
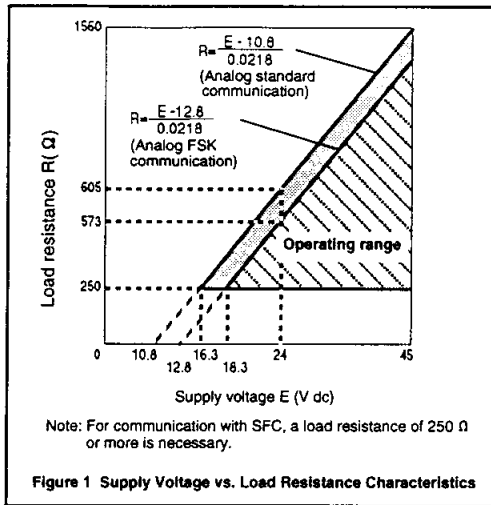

Note) When the fill liquid is for general purposes, makesure before using your transmitter that the conditions in both Figure 2-1 and Figure 2-2 are met.

Max Working Pressure

<ForName>

Note1. Max Working Pressure depends on flange rating, flange materials and operating temperature. Please refer to the following data.

Operating range of temperature depends on specification of transmitters

Note2. In case of flange type (JTF940□, JTC940□) and remote sealed type (JTU940□, JTH940□),

Max Working Pressure depends on the smaller value of either 1.5MPa or following data.

Note3. In case of absolute remote sealed type (JTS940□),

Max Working Pressure depends on the smaller value of either 3.5MPa abs or following data.

As for the following data, the vertical axis represent gage pressure.

Please exchange of units from gage pressure to absolute pressure, when you use.

Note4. In case of remote sealed type (JTH980□), Max Working Pressure depends on the smaller value of either 10MPa or following data.

Note5. In case of 1/2B remote sealed type (JTE929□, JTE930□, JTH980□),

Max Working Pressure depends on the smaller value of either 5.1MPa or the following data as for adoptor flange (HF).

	JIS	JPI/ANSI
Carbon steel		
SUS304		
SUS316		
SUS316L		

Process pipe connection:

Flanges (both higher and lower pressure sides)

Flush diaphragm:

JIS10K, 20K, 30K, 63K, and 80A (RF) equivalents

ANSI150, 300, and 600-3B (RF) equivalents

JPI150, 300, and 600-3B (RF) equivalents

Extended diaphragm:

JIS10K, 20K, 30K, and 100A (RF) equivalents

ANSI150 and 300-4B (RF) equivalents

JPI150 and 300-4B (RF) equivalents

Electrical conduit connection:

G1/2 internal thread

1/2NPT internal thread (Not usable with JIS explosion-proof models)

Materials:

Center body: SUS316

Transmitter case: Aluminum alloy

Meter body cover: SUSF304

Wetted parts materials:

SUS316 (SUS316L for diaphragm only)

Hastelloy C, tantalum, etc.

Flange materials:

Carbon steel (SF440A), SUS304, SUS316, SUS316L

Bolts and nuts materials (for fastening meter body cover):

Carbon steel (SNB7), SUS630

Capillary section:

Capillary tube length: 2, 3, 4, 5, 6, 7, 8, 9, and 10 m

Capillary tube material: SUS316

Armored tube material: SUS304

Coating (optional): Olefin coating to improve corrosion resistance (Not usable with high-temperature vacuum or high-temperature high-vacuum models)

Finish: Housing: light beige (Munsell 4Y7.2/1.3)

Cap: dark beige (Munsell 10YR4.7/0.5)

Corrosion-resistant finish:

Standard: Corrosion-resistant paint (Baked acrylic paint)

Corrosion-resistant finish:

Corrosion-resistant paint (Baked acrylic paint), fungus-proof finish

Corrosion-proof finish:

Corrosion-proof paint (Baked epoxy paint), fungus-proof finish

Corrosion-resistant finish (silver paint):

Transmitter case is silver-painted in addition to the above corrosion-resistant finish.

Built-in indicating meter:

The digital LCD indicator (optional) indicates actual flow rates (in SI units) and can be set freely between -19999 and 19999 (4.5 digits). For actual calibration, specify the following items when placing your order:

- Actual calibration range
- Actual calibration unit
- Proportional representation and instructions about square-root extraction

Various kinds of data can be set using the SFC smart communicator (Ver. 7.1 or later).

Burnout feature:

Choice of three states at abnormal condition:

Burnout of output values: none

upper limit

lower limit

Grounding:

Class 3 grounding (grounding resistance 100 Ω max.)

Mounting:

Direct mounting on the process side

For mounting the transmitter body, choose between the following two methods:

- (1) Using 2-inch pipe mounting brackets: Mount the transmitter on a horizontal or vertical 2-inch pipe, then use the brackets.

Materials: Brackets: carbon steel

U bolts and nuts: SUS304

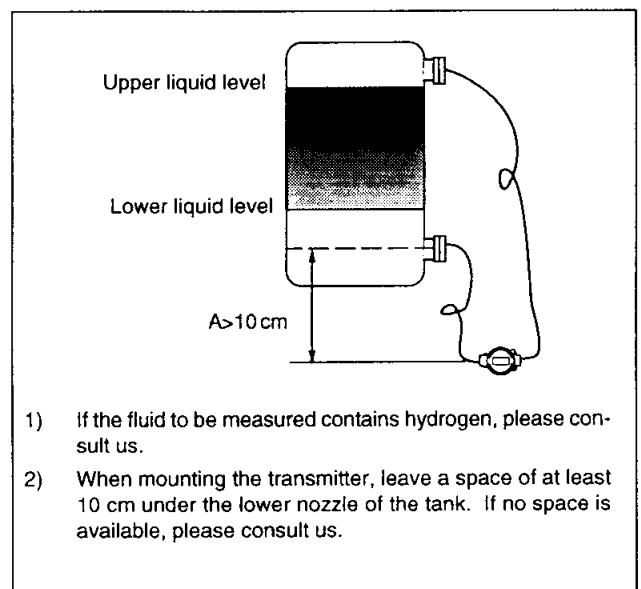
Mounting Notes

- 1) If the fluid to be measured contains hydrogen, please consult us.
- 2) When mounting the transmitter, leave a space of at least 10 cm under the lower nozzle of the tank. If no space is available, please consult us.

Mounting (continued):

(2) Direct mounting (for general purpose model only)

Mount the transmitter directly on the tank using the direct mounting kit supplied.

<Features>

- Direct mounting saves space.
- Capillary tubes can be neatly arranged using tube clamps. This also improves temperature characteristics.

Direct mounting kit (weight: about 600 g)

Component	Material
Adaptor	SUS13 (SUS304 equivalent)
Adaptor fastening bolt	SUS304 (M8)
Tube clamp	Brass + nickel plating

Weight: Approx. 19.8 kg
(including JIS10K-80A flange and capillary 5 m long)

Tank Level Setting by Direct Mounting Method

Notes)

- *1) When fitting a protective pipe upward as shown in the figure, be sure to specify a capillary tube with olefin coating. If a capillary tube without olefin coating is to be used, set the capillary withdrawal direction downward a little.
- *2) When bending a capillary tube, as shown in the figure, do not twist it. Also note that the minimum bending diameter is about 5 cm. Do not apply excessive force.
- *3) Three tube clamps are supplied as an option. Referring to the figure, fix the tube at appropriate places. Do not tighten the clamps to the extent of deforming the tube.
- *4) Before zero adjusting using the SFC, be sure to set the inter-flange height L (m) and use the capillary fill fluid temperature correction function.

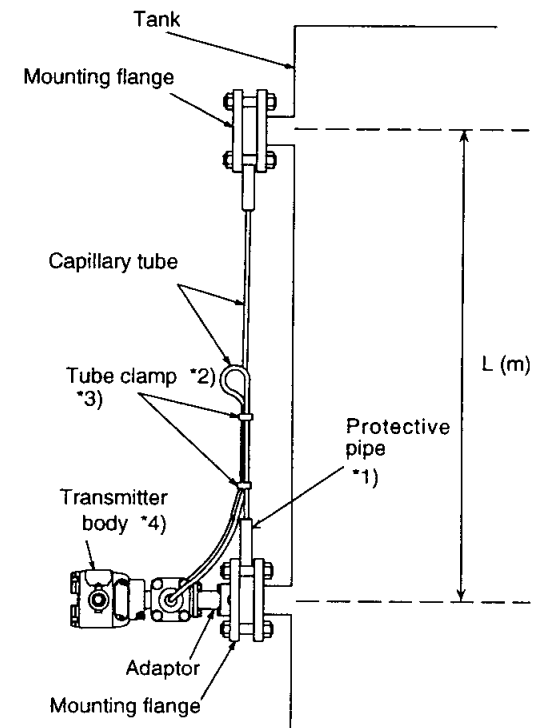

Optional Specifications

External zero adjustment function:

The transmitter can be easily zero-adjusted in the field with a flat-blade screwdriver.

Additional lightning protection:

It is possible to achieve a lightning protection performance of 200 kV, 2000 A, twice the standard performance (100 kV, 1000 A). This is advisable when the transmitter is to be used in lightning-prone areas such as mountains, hills and wherever high-performance lightning protection is required.

Elbow:

This is an adaptor for changing the electrical conduit connection port from the horizontal to the vertical direction, if required by wiring conditions in the field. One or two elbows may be used as needed.

Water inhibiting treatment (including oil inhibiting treatment):

The transmitter is shipped with dry and oil-free wetted parts.

Oil inhibiting treatment:

The transmitter is shipped with oil-free wetted parts. (The vent drain plug is coated with a small amount of fluorine oil to prevent galling.)

FEP protective film:

Use FEP protective films when corrosive fluids are used or to inhibit ion migration from metal diaphragms.

Working temperature range:

0 to 110°C

Working pressure range:

atmospheric pressure to flange rating

(up to JIS10K, ANSI/JPI150)

(Not usable under negative pressure)

Electric power specification:

This specification applies where stringent quality control is required, such as in the electric power and city gas industries.

Special burnout (3.2 mA):

The burnout output value (in the lower-limit direction) under abnormal conditions shall be 3.2 mA (-5%) or less.

Test report:

The test report indicates the results of appearance, I/O characteristics, insulation resistance, and breakdown voltage tests.

Mill sheet:

The mill sheet shows the chemical composition, heat-treatment conditions, and mechanical properties of the materials used for the wetted parts.

Documents of conformance to the High Pressure Gas Control Law (for general purposes):

This specification applies when documents verifying conformance to the High Pressure Gas Control Law are required. The documents consist of a strength calculation sheet, the mill sheet, and a pressure resistance and gas-tightness test result sheet.

Strength calculation sheet:

The strength calculation sheet indicates the strength of the meter body cover, flanges, bolts, etc.

Pressure resistance and gas-tightness tests (for general purposes):

The pressure resistance and gas-tightness test result sheet shows the results of a pressure resistance test (under water pressure for 10 minutes) performed on the wetted parts.

Traceability certificate:

This certificate consists of three parts: the transmitter's measurement control system configuration diagram, a calibration certificate, and a test report.

Conformance to non-SI units:

We deliver transmitters set to any non-SI unit you specify.

Transmitter Handling Notes

To make the most of the performance this transmitter can offer, please use it properly noting the points mentioned below. Before using it, please read the Instruction Manual.

Transmitter Installation Notes

Warning

- When installing the transmitter, ensure that gaskets do not protrude from connecting points into the process (such as adapter flange connection points and connecting pipes and flanges). Gasket protrusion may cause leaks and output errors.
- Do not use the transmitter outside its defined pressure, temperature, and connection specifications. A serious accident may otherwise occur due to damage and leaks.
- When performing wiring work in explosion-proof areas, follow the work method specified in the explosion-proof guidelines. In addition, when the wiring for an explosion-proof product is a pull-in pressure-resistant packing-cable, be sure to use a pressure-resistant packing-cable adapter certified by Yamatake-Honeywell.
- When conduits are used for connection, be sure to use conduit fittings certified by Yamatake-Honeywell.

Caution

- After installing the transmitter, do not step on it. Using it as a foothold or the like could make it collapse and cause injury.
- Be careful not to hit the glass indicator with tools etc. This could break the glass and cause injury.
- This transmitter is heavy. Wear safety shoes and take care when installing it.

Wiring Notes

Warning

- To avoid shocks, do not perform electrical wiring work with wet hands or with live wires.

Caution

- Do wiring work properly in conformance with the specifications. Wiring mistakes may result in breakdown.
- Use a power supply that conforms to the specifications. Use of an improper power supply may result in breakdown.

Performance

Shown for each item are the upper limit (URV) ⁽¹⁾ and the lower limit (LRV) ⁽²⁾ of the calibration range or the percentage ratio of the maximum value of the span to χ (kPa).

JTR929A (for general purpose and high-temperature models)

Material for Wetted Parts: SUS316

Accuracy	Linear output: $\pm 0.3\%$ ($\chi \geq 12.5\text{kPa}$ {1250mmH ₂ O}) $\pm (0.3 \times \frac{12.5}{\chi})\%$ ($\chi < 12.5\text{kPa}$ {1250mmH ₂ O})
	Square-root output: When output is 50 to 100%: same as linear output When output is 7.1 to 50%: linear output $\times \frac{50}{\text{square-root output } \%}$ When output is less than 7.1%: dropout
Temperature characteristics (Shift from the set range)	Zero shift: $\pm 0.75\%$ ($\chi \geq 25\text{kPa}$ {2500mmH ₂ O}) $\pm 0.75 \times \frac{25}{\chi}\%$ ($\chi < 25\text{kPa}$ {2500mmH ₂ O})
Change of 55°C	Combined shift: (including zero and span shifts) $\pm 1.6\%$ ($\chi \geq 25\text{kPa}$ {2500mmH ₂ O}) $\pm 1.6 \times \frac{25}{\chi}\%$ ($\chi < 25\text{kPa}$ {2500mmH ₂ O})
Static pressure effect (Shift with respect to setting range)	Zero shift: $\pm 0.75\%$ ($\chi \geq 25\text{kPa}$ {2500mmH ₂ O}) $\pm (0.75 \times \frac{25}{\chi})\%$ ($\chi < 25\text{kPa}$ {2500mmH ₂ O})
Change of 7MPa {70kgf/cm²}	Combined shift: (including zero and span shifts) $\pm 1.00\%$ ($\chi \geq 25\text{kPa}$ {2500mmH ₂ O}) $\pm (1.00 \times \frac{25}{\chi})\%$ ($\chi < 25\text{kPa}$ {2500mmH ₂ O})

JTR930A (for general purpose and high-temperature models)

Material for Wetted Parts: SUS316

Accuracy ⁽³⁾	Linear output: $\pm 0.2\%$ ($\chi \geq 210\text{kPa}$ {2.1kgf/cm ² }) $\pm (0.05 + 0.15 \times \frac{210}{\chi})\%$ ($\chi < 210\text{kPa}$ {2.1kgf/cm ² })
	Square-root output: When output is 50 to 100%: same as linear output When output is 7.1 to 50%: linear output $\times \frac{50}{\text{square-root output } \%}$ When output is less than 7.1%: dropout
Temperature characteristics (Shift from the set range) ⁽³⁾	Zero shift: $\pm (0.25 + 0.5 \times \frac{210}{\chi})\%$
Change of 55°C	Combined shift: (including zero and span shifts) $\pm 1.6\%$ ($\chi \geq 210\text{kPa}$ {2.1kgf/cm ² }) $\pm (1.0 + 0.6 \times \frac{210}{\chi})\%$ ($\chi < 210\text{kPa}$ {2.1kgf/cm ² })
Static pressure effect (Shift with respect to setting range) ⁽³⁾	Zero shift: $\pm (0.75 \times \frac{700}{\chi})\%$
Change of 7MPa {70kgf/cm²}	Combined shift: $\pm (1.00 \times \frac{700}{\chi})\%$

JTR929A (for general purpose and high-temperature models) Material for Wetted Parts: Hastelloy C, Tantalum

<p>Accuracy</p>	<p>Linear output: $\pm 0.4\%$ ($\chi \geq 12.5\text{kPa}$ {1250mmH₂O}) $\pm (0.4 \times \frac{12.5}{\chi})\%$ ($\chi < 12.5\text{kPa}$ {1250mmH₂O})</p> <p>Square-root output: When output is 50 to 100%: same as the linear output When output is 7.1 to 50%: linear output $\times \frac{50}{\text{square-root output \%}}$ When output is less than 7.1%: dropout</p>
<p>Temperature characteristics (Shift from the set range) Change of 30°C (Range from -5 to 55°C)</p>	<p>Zero shift: $\pm 2.15\%$ ($\chi \geq 25\text{kPa}$ {2500mmH₂O}) $\pm 2.15 \times \frac{25}{\chi} \%$ ($\chi < 25\text{kPa}$ {2500mmH₂O})</p> <p>Combined shift: (including zero and span shifts) $\pm 3.0\%$ ($\chi \geq 25\text{kPa}$ {2500mmH₂O}) $\pm 3.0 \times \frac{25}{\chi} \%$ ($\chi < 25\text{kPa}$ {2500mmH₂O})</p>
<p>Static pressure effect (Shift with respect to setting range) Change of 7MPa {70kgf/cm²}</p>	<p>Zero shift: $\pm 6.00\%$ ($\chi \geq 25\text{kPa}$ {2500mmH₂O}) $\pm (6.00 \times \frac{25}{\chi})\%$ ($\chi < 25\text{kPa}$ {2500mmH₂O})</p> <p>Combined shift: (including zero and span shifts) $\pm 7.00\%$ ($\chi \geq 25\text{kPa}$ {2500mmH₂O}) $\pm (7.00 \times \frac{25}{\chi})\%$ ($\chi < 25\text{kPa}$ {2500mmH₂O})</p>

JTR930A (for general purpose and high-temperature models) Material for Wetted Parts: Hastelloy C, Tantalum

<p>Accuracy ^(*)</p>	<p>Linear output: $\pm 0.2\%$ ($\chi \geq 210\text{kPa}$ {2.1kgf/cm²}) $\pm (0.05 + 0.15 \times \frac{2.1}{\chi})\%$ ($\chi < 210\text{kPa}$ {2.1kgf/cm²})</p> <p>Square-root output: When output is 50 to 100%: same as the linear output When output is 7.1 to 50%: linear output $\times \frac{50}{\text{square-root output \%}}$ When output is less than 7.1%: dropout</p>
<p>Temperature characteristics (Shift from the set range) Change of 30°C ^(*) (Range from -5 to 55°C)</p>	<p>Zero shift: $\pm (0.15 + 0.7 \times \frac{210}{\chi})\%$</p> <p>Combined shift: (including zero and span shifts) $\pm 1.75\%$ ($\chi \geq 210\text{kPa}$ {2.1kgf/cm²}) $\pm (1.00 + 0.75 \times \frac{210}{\chi})\%$ ($\chi < 210\text{kPa}$ {2.1kgf/cm²})</p>
<p>Static pressure effect (Shift with respect to setting range) ^(*) Change of 7MPa {70kgf/cm²}</p>	<p>Zero shift: $\pm (0.75 \times \frac{700}{\chi})\%$</p> <p>Combined shift: (including zero and span shifts) $\pm (1.00 \times \frac{700}{\chi})\%$</p>

JTR929A (for high-temperature vacuum and high-temperature high-vacuum models)
Material for Wetted Parts: SUS316

Accuracy	Linear output:	$\pm 0.3\%$ $\pm (0.3 \times \frac{12.5}{x})\%$	$(\chi \geq 12.5\text{kPa } \{1250\text{mmH}_2\text{O}\})$ $(\chi < 12.5\text{kPa } \{1250\text{mmH}_2\text{O}\})$
	Square-root output:	When output is 50 to 100%: same as the linear output When output is 7.1 to 50%: $\text{linear output} \times \frac{50}{\text{square-root output } \%}$ When output is less than 7.1%: dropout	
Temperature characteristics (Shift from the set range) Change of 30°C (Range from -5 to 55°C)	Zero shift:	$\pm 1.5\%$ $\pm 1.5 \times \frac{25}{x}\%$	$(\chi \geq 25\text{kPa } \{2500\text{mmH}_2\text{O}\})$ $(\chi < 25\text{kPa } \{2500\text{mmH}_2\text{O}\})$
	Combined shift: (including zero and span shifts)	$\pm 2.5\%$ $\pm 2.5 \times \frac{25}{x}\%$	$(\chi \geq 25\text{kPa } \{2500\text{mmH}_2\text{O}\})$ $(\chi < 25\text{kPa } \{2500\text{mmH}_2\text{O}\})$
Static pressure effect (Shift with respect to setting range) 7MPa {70kgf/cm ² }	Zero shift:	$\pm 6.00\%$ $\pm (6.00 \times \frac{25}{x})\%$	$(\chi \geq 25\text{kPa } \{2500\text{mmH}_2\text{O}\})$ $(\chi < 25\text{kPa } \{2500\text{mmH}_2\text{O}\})$
	Combined shift: (including zero and span shifts)	$\pm 7.00\%$ $\pm (7.00 \times \frac{25}{x})\%$	$(\chi \geq 25\text{kPa } \{2500\text{mmH}_2\text{O}\})$ $(\chi < 25\text{kPa } \{2500\text{mmH}_2\text{O}\})$

JTR930A (for high-temperature vacuum and high-temperature high-vacuum models)
Material for Wetted Parts: SUS316

Accuracy ^(*)	Linear output:	$\pm 0.2\%$ $\pm (0.05 + 0.15 \times \frac{210}{x})\%$	$(\chi \geq 210\text{kPa } \{2.1\text{kgf/cm}^2\})$ $(\chi < 210\text{kPa } \{2.1\text{kgf/cm}^2\})$
	Square-root output:	When output is 50 to 100%: same as the linear output When output is 7.1 to 50%: $\text{linear output} \times \frac{50}{\text{square-root output } \%}$ When output is less than 7.1%: dropout	
Temperature characteristics (Shift from the set range) Change of 30°C ^(*) (Range from -5 to 55°C)	Zero shift:	$\pm (0.15 + 0.70 \times \frac{210}{x})\%$	
	Combined shift: (including zero and span shifts)	$\pm 1.75\%$ $\pm (1.00 + 0.75 \times \frac{210}{x})\%$	$(\chi \geq 210\text{kPa } \{2.1\text{kgf/cm}^2\})$ $(\chi < 210\text{kPa } \{2.1\text{kgf/cm}^2\})$
Static pressure effect (Shift with respect to setting range) ^(*) Change of 7MPa {70kgf/cm ² }	Zero shift:	$\pm (0.75 \times \frac{700}{x})\%$	
	Combined shift:	$\pm (1.00 \times \frac{700}{x})\%$	

JTR929A (for high-temperature vacuum and high-temperature high-vacuum models)
Material for Wetted Parts: Hastelloy C, Tantalum

Accuracy	Linear output:	$\pm 0.4\%$ $\pm (0.4 \times \frac{12.5}{\chi})\%$	$(\chi \geq 12.5\text{kPa } \{1250\text{mmH}_2\text{O}\})$ $(\chi < 12.5\text{kPa } \{1250\text{mmH}_2\text{O}\})$
	Square-root output:	When output is 50 to 100%: same as the linear output When output is 7.1 to 50%: linear output $\times \frac{50}{\text{square-root output } \%}$ When output is less than 7.1%: dropout	
Temperature characteristics (Shift from the set range) Change of 30°C (Range from -5 to 55°C)	Zero shift:	$\pm 2.15\%$ $\pm 2.15 \times \frac{25}{\chi} \%$	$(\chi \geq 25\text{kPa } \{2500\text{mmH}_2\text{O}\})$ $(\chi < 25\text{kPa } \{2500\text{mmH}_2\text{O}\})$
	Combined shift: (including zero and span shifts)	$\pm 3.0\%$ $\pm 3.0 \times \frac{25}{\chi} \%$	$(\chi \geq 25\text{kPa } \{2500\text{mmH}_2\text{O}\})$ $(\chi < 25\text{kPa } \{2500\text{mmH}_2\text{O}\})$
Static pressure effect (Shift with respect to setting range) Change of 7MPa {70kgf/cm ² }	Zero shift:	$\pm 6.00\%$ $\pm (6.00 \times \frac{25}{\chi})\%$	$(\chi \geq 25\text{kPa } \{2500\text{mmH}_2\text{O}\})$ $(\chi < 25\text{kPa } \{2500\text{mmH}_2\text{O}\})$
	Combined shift: (including zero and span shifts)	$\pm 7.00\%$ $\pm (7.00 \times \frac{25}{\chi})\%$	$(\chi \geq 25\text{kPa } \{2500\text{mmH}_2\text{O}\})$ $(\chi < 25\text{kPa } \{2500\text{mmH}_2\text{O}\})$

JTR930A (for high-temperature vacuum and high-temperature high-vacuum models)
Material for Wetted Parts: Hastelloy C, Tantalum

Accuracy ^(*)	Linear output:	$\pm 0.2\%$ $\pm (0.05 + 0.15 \times \frac{2.1}{\chi})\%$	$(\chi \geq 210\text{kPa } \{2.1\text{kgf/cm}^2\})$ $(\chi < 210\text{kPa } \{2.1\text{kgf/cm}^2\})$
	Square-root output:	When output is 50 to 100%: same as the linear output When output is 7.1 to 50%: linear output $\times \frac{50}{\text{square-root output } \%}$ When output is less than 7.1%: dropout	
Temperature characteristics (Shift from the set range) Change of 30°C ^(*) (Range from -5 to 55°C)	Zero shift:	$\pm (0.15 + 0.7 \times \frac{210}{\chi})\%$	
	Combined shift: (including zero and span shifts)	$\pm 1.75\%$ $\pm (1.00 + 0.75 \times \frac{210}{\chi})\%$	$(\chi \geq 210\text{kPa } \{2.1\text{kgf/cm}^2\})$ $(\chi < 210\text{kPa } \{2.1\text{kgf/cm}^2\})$
Static pressure effect (Shift with respect to setting range) ^(*) Change of 7MPa {70kgf/cm ² }	Zero shift:	$\pm (0.75 \times \frac{700}{\chi})\%$	
	Combined shift: (including zero and span shifts)	$\pm (1.00 \times \frac{700}{\chi})\%$	

Notes) ^(*): URV denotes the value for 100% (20 mA dc) output.

⁽²⁾: LRV denotes value for 0% (4 mA dc) output.

⁽³⁾: Within a range of URV ≥ 0 and LRV ≥ 0

Model Number Configuration Table

ST3000 Ace Remote-Sealed Differential Pressure Transmitter (JTR) with Flush Diaphragm Flange for General Purpose and High-Temperature Models

		Basic model number	Selections	Optional selections	Options
Measuring span		2.5~100kPa	J T R 9 2 9 A		X X No optional specifications
		35~700kPa	J T R 9 3 0 A		A 2 External zero adjustment
Forms of output/communication		4 to 20mA dc (analog standard communication)	1		A 4 Additional lightning protection
		4 to 20 mA dc (analog FSK communication)	2		B 7 For special local field meter
		DE output	3		G 1 One elbow (left)
Wetted parts material		SUS316 (diaphragm: SUS316L)	2		G 2 One elbow (right)
		Tantalum	4		G 3 Two elbows
		Hastelloy C	H		D 1 Water inhibiting treatment (including oil inhibition)
		SUS316L	8		D 2 Oil inhibition
Sealing liquid		For general purposes: silicone oil	1		D 3 FEP protective film
		For oxygen service: fluorine oil	2		J 2 Power specifications
		High-temperature model: silicone oil (Note 1)	3		J 8 Special burnout (3.2 mA)
		For chlorine service: fluorine oil	5		T 1 Test report
Flange standard		JIS10K	A		T 2 Mill sheet
		JIS20K	C		T 3 Document conforming to High Pressure Gas Control Law (for general purposes)
		JIS30K	D		T 5 Strength calculation sheet
		JIS63K	F		T 6 Pressure resistance/gas-tightness test (for general purposes)
		ANSI150	G		T 8 Traceability certificate
		ANSI300	H		U 2 Non-SI unit conformance
		ANSI600	J		<input type="checkbox"/> Other
		JPI150	N		
		JPI300	P		
		JPI600	Q		
Flange diameter		3 B / 80 A	2		X Electrical conduit and explosion-proof status
Flange shape		Standard	I		1 G1/2, not explosion-proof
Flange material/Bolt/nut material		Carbon steel/Carbon steel	A		2 G1/2, JIS explosion-proof, with single standard conduit fittings
		Carbon steel/SUS630	C		3 G1/2, JIS explosion-proof, with double standard conduit fittings
		SUS304/Carbon steel	D		6 G1/2, JIS explosion-proof, with single standard packing
		SUS304/SUS630	F		3 G1/2, JIS explosion-proof, with double standard packing
		SUS316/Carbon steel	G		6 G1/2, JIS intrinsically safe
		SUS316/SUS630	J		A 1/2 NPT, not explosion-proof
		SUS316L/Carbon steel	K		<input type="checkbox"/> Other
		SUS316L/SUS630	M		X indicator
Capillary length		2 m	2		1 No meter
		3 m	3		2 Digital meter with standard reading (0 to 100%)
		4 m	4		2 Digital meter with actual reading
		5 m	5		X Anticorrosion treatment
		6 m	6		A Standard coating
		7 m	7		B Anticorrosion treatment
		8 m	8		D Heavy-duty anticorrosion treatment
		9 m	Q		D Silver anticorrosion treatment
		10 m	A		X Flange processing
		2 m (Olefin covering)	B		<input type="checkbox"/> None (Standard: JISRa3.2 (12.5 S))
		3 m (Olefin covering)	C		<input type="checkbox"/> Other
		4 m (Olefin covering)	H		X Burnout feature
		5 m (Olefin covering)	D		U None
		6 m (Olefin covering)	J		D Upper limit of output at abnormal condition
		7 m (Olefin covering)	E		D Lower limit of output at abnormal condition
		8 m (Olefin covering)	F		X Mounting bracket
		9 m (Olefin covering)	K		I Carbon steel (mounted on 2B pipe)
		10 m (Olefin covering)	G		P Direct mounting (general purpose model only)
					<input type="checkbox"/> Other

Note 1) The temperature range of tantalum wetted parts is -10 to 180°C.

ST3000 Ace Remote-Sealed Differential Pressure Transmitter (JTR) with Extended Diaphragm Flange for General Purpose and High-Temperature Models

Basic model number		Selections				Optional selections				Options	
Measuring span		2.5~100kPa	J T R 9 2 9 A								
		35~700kPa	J T R 9 3 0 A								
Forms of output/communication	4 to 20mA dc (analog standard communication)	1									
	4 to 20 mA dc (analog FSK communication)	2									
	DE output	3									
Wetted parts material	SUS316 (diaphragm: SUS316L)	2									
	SUS316L	8									
Sealing liquid	For general purposes: silicone oil	1									
	For oxygen service: fluorine oil	2									
	High-temperature model: silicone oil	3									
Flange standard	JIS10K		A								
	JIS20K		C								
	JIS30K		D								
	ANSI150		G								
	ANSI300		H								
	JPI150		N								
	JPI300		P								
Flange diameter	4 B / 100 A			1							
Flange shape	Length of extension 50mm				2						
	Length of extension 100mm				3						
	Length of extension 150mm				4						
	Length of extension 200mm				5						
	Length of extension 250mm				6						
	Length of extension 300mm				7						
Flange material/ Bolt/nut material	Carbon steel / Carbon steel		A								
	Carbon steel / SUS630		C								
	SUS304 / Carbon steel		D								
	SUS304 / SUS630		F								
	SUS316 / Carbon steel		G								
	SUS316 / SUS630		J								
	SUS316L / Carbon steel		K								
	SUS316L / SUS630		M								
Capillary length	2 m				2						
	3 m				3						
	4 m				4						
	5 m				5						
	6 m				6						
	7 m				7						
	8 m				8						
	9 m				Q						
	10m				A						
	2 m (Olefin covering)				B						
	3 m (Olefin covering)				C						
	4 m (Olefin covering)				H						
	5 m (Olefin covering)				D						
	6 m (Olefin covering)				J						
7 m (Olefin covering)				E							
8 m (Olefin covering)				F							
9 m (Olefin covering)				K							
10 m (Olefin covering)				G							
X	Electrical conduit and explosion-proof status										G1/2, not explosion-proof
1											G1/2, JIS explosion-proof, with single standard conduit fittings
H											G1/2, JIS explosion-proof, with double standard conduit fittings
2											G1/2, JIS explosion-proof, with single standard packing
3											G1/2, JIS explosion-proof, with double standard packing
6											G1/2, JIS intrinsically safe
A											1/2 NPT, not explosion-proof
<input type="checkbox"/>											Other
X	Indicator										No meter
1											Digital meter with standard reading (0 to 100%)
2											Digital meter with actual reading
X	Anticorrosion treatment										Standard coating
A											Anticorrosion treatment
B											Heavy-duty anticorrosion treatment
D											Silver anticorrosion treatment
X	Flange processing										None (Standard: JISRa3.2 (12.5 S))
<input type="checkbox"/>											Other
X	Burnout feature										None
U											Upper limit of output at abnormal condition
D											Lower limit of output at abnormal condition
X	Mounting bracket										None
I											Carbon steel (mounted on 2B pipe)
P											Direct mounting (general purpose model only)
<input type="checkbox"/>											Other

ST3000 Ace Remote-Sealed Differential Pressure Transmitter (JTR) with Extended Diaphragm Flange for High-Temperature Vacuum and High-Temperature High-Vacuum Models

Basic model number		Selections								Optional selections				Options			
Measuring span		2.5~100kPa	J	T	R	9	2	9	A					X X	No optional specifications		
		35~700kPa	J	T	R	9	3	0	A					A 2	External zero adjustment		
Forms of output/communication		4 to 20mA dc (analog standard communication)	1													A 4	Additional lightning protection
		4 to 20 mA dc (analog FSK communication)	2													B 7	For special local field meter
		DE output	3													G 1	One elbow (left)
Wetted parts material		SUS316 (diaphragm: SUS316L)	2													G 2	One elbow (right)
		SUS316L	8													G 3	Two elbows
Sealing liquid		For high-temperature vacuum models: silicone oil	4													D 1	Water inhibiting treatment (including oil inhibition)
		For high-temperature high-vacuum models: silicone oil	7													D 2	Oil inhibition
Flange standard		JIS10K	A													J 2	Power specifications
		JIS20K	C													J 8	Special burnout (3.2 mA)
		JIS30K	D													T 1	Test report
		ANSI150	G													T 2	Mill sheet
		ANSI300	H													T 3	Document conforming to High Pressure Gas Control Law (for general purposes)
		JPI150	N													T 5	Strength calculation sheet
		JPI300	P													T 6	Pressure resistance/gas-tightness test (for general purposes)
Flange diameter		4 B / 100A	1													T 8	Traceability certificate
Flange shape		Length of extension 50mm	2													U 2	Non-SI unit conformance
		Length of extension 100mm	3													<input type="checkbox"/>	Other
		Length of extension 150mm	4														
		Length of extension 200mm	5														
		Length of extension 250mm	6														
		Length of extension 300mm	7														
Flange material/ Bolt/nut material		Carbon steel / Carbon steel	A													X	Electrical conduit and explosion-proof status
		Carbon steel / SUS630	C													1	explosion-proof status
		SUS304 / Carbon steel	D													H	
		SUS304 / SUS630	F													2	
		SUS316 / Carbon steel	G													3	
		SUS316 / SUS630	J													6	
		SUS316L / Carbon steel	K													A	
		SUS316L / SUS630	M													<input type="checkbox"/>	Other
Capillary length		2 m	2													X	Indicator
		3 m	3													1	
		4 m	4													2	
		5 m	5													X	Anticorrosion treatment
		6 m	6													A	
		7 m	7													B	
		8 m	8													D	
		9 m	Q													<input type="checkbox"/>	Flange processing
		10m	A													<input type="checkbox"/>	Other
																X	Burnout feature
																U	
																D	
																X	Mounting bracket
																1	
																<input type="checkbox"/>	Other

Dimensions

(Unit: mm)

JTR929A/930A General Purpose and High-Temperature Models

Extended Diaphragm Flange

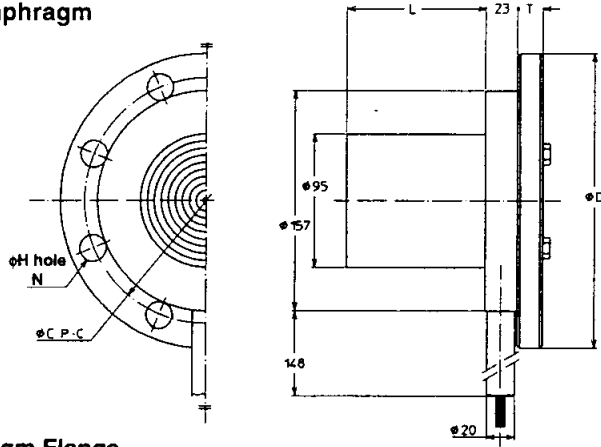

Flush Diaphragm Flange

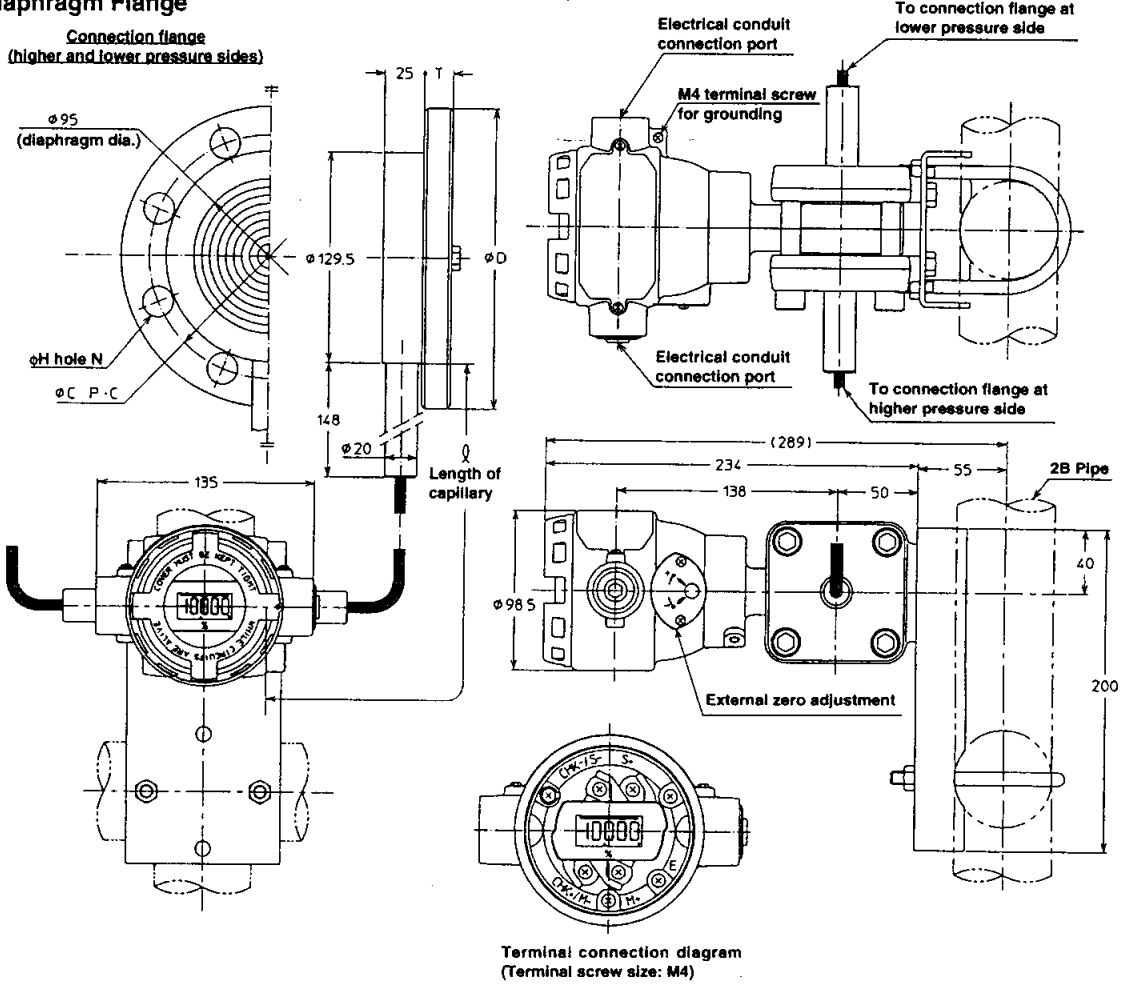

Notes)

1. The transmitter can be mounted in various ways by changing the position of the mounting bracket. (A typical example is shown in the figure.)
2. To prevent vibration, you are recommended to fasten the capillary tube mid-length.
3. Select a gasket that will not contact the diaphragm after it is tightened.
4. When the volume of suppression is larger than one half of the adjustment span, the higher pressure side and the lower pressure side of the process connection end flange are opposite to those shown in the figure. When using the transmitter to measure liquid levels, connect at H and L marks on the meter body as shown in the figure below.

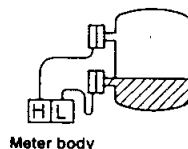

Extended Diaphragm Flange

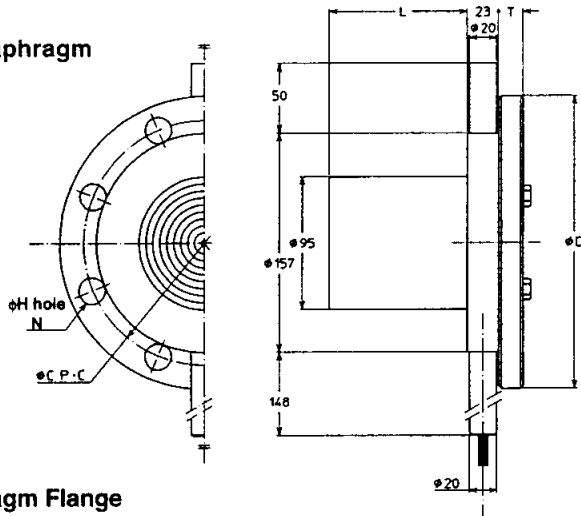

Flush Diaphragm Flange

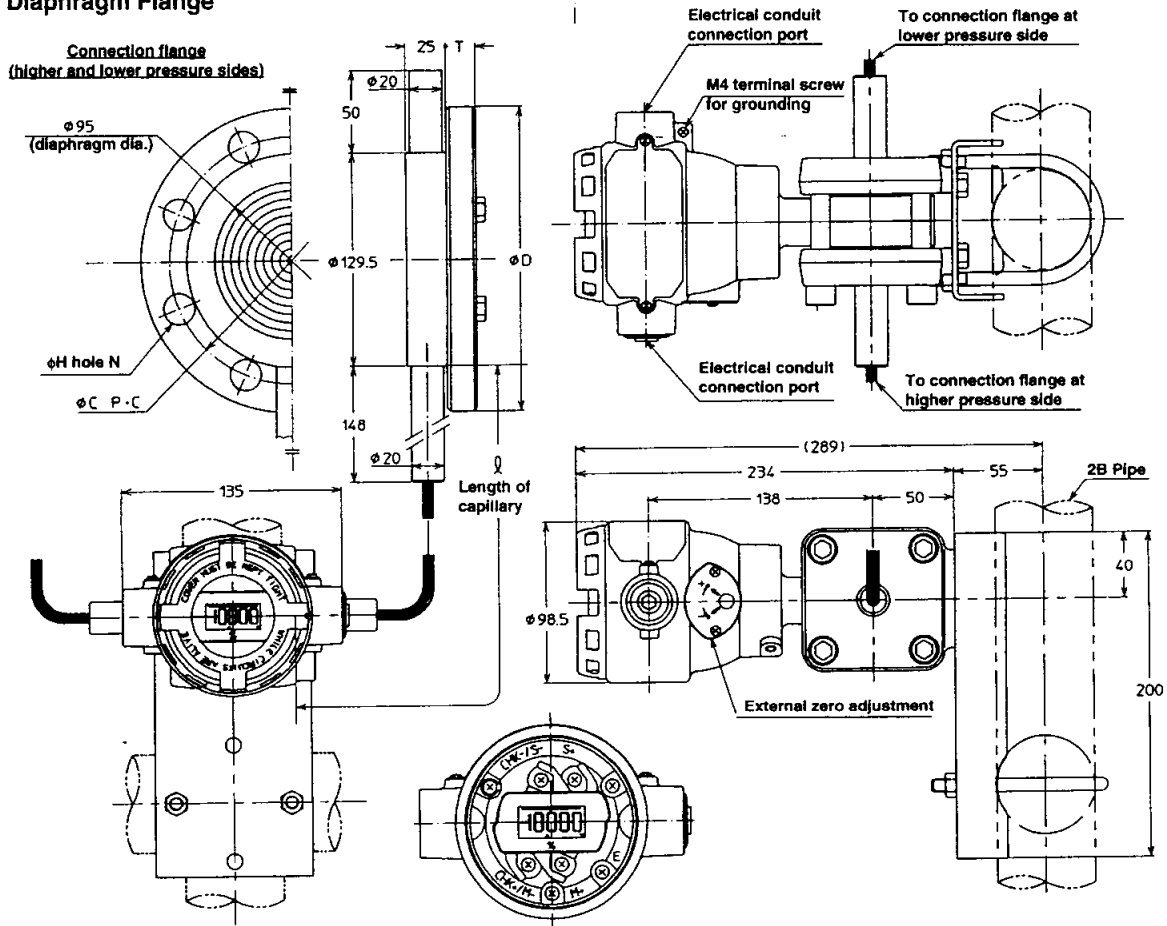

Terminal connection diagram
(Terminal screw size: M4)

Notes)

1. The transmitter can be mounted in various ways by changing the position of the mounting bracket. (A typical example is shown in the figure.)
2. To prevent vibration, you are recommended to fasten the capillary tube mid-length.
3. Select a gasket that will not contact the diaphragm after it is tightened.
4. When the volume of suppression is larger than one half of the adjustment span, the higher pressure side and the lower pressure side of the process connection end flange are opposite to those shown in the figure. When using the transmitter to measure liquid levels, connect at H and L marks on the meter body as shown in the figure below.

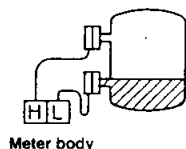

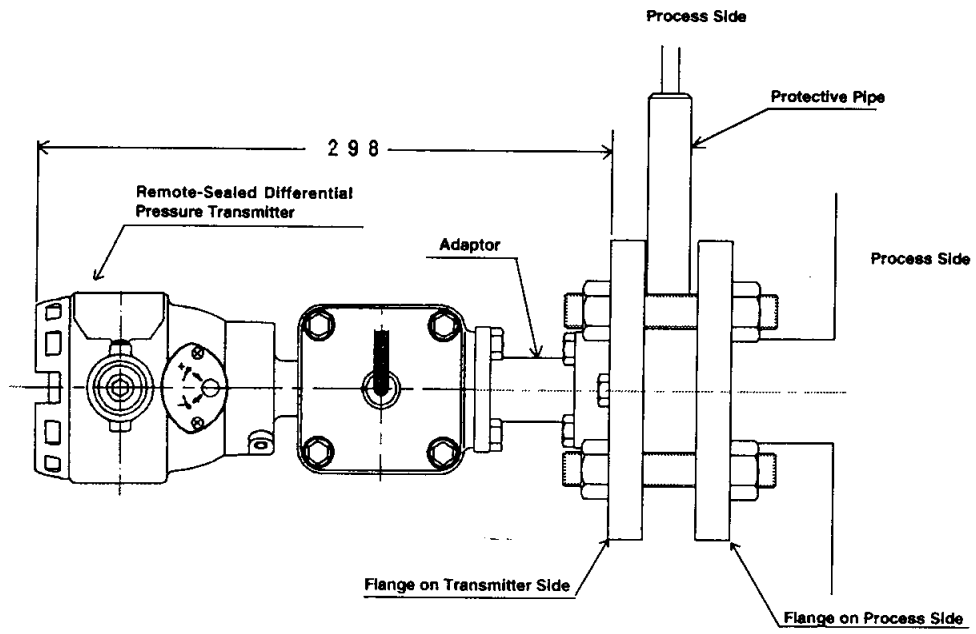

Adaptor Assembly Drawing (JTR Type + Adaptor)

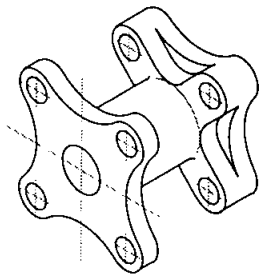

Adaptor Outline Drawing

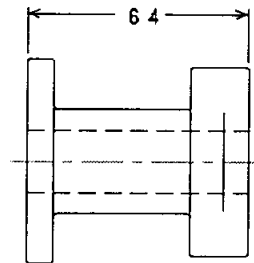

Adaptor Dimension Drawing

**Table of Flange Dimensions
(Flush Diaphragm Flange)**

(Unit: mm)

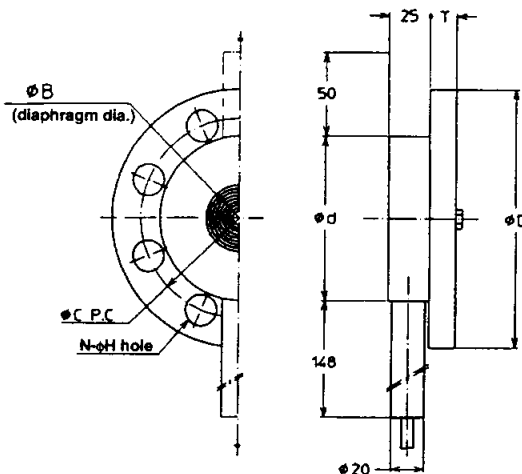

Table of Flange Dimensions

Flange standard	ϕD	T	ϕC	N	ϕH	ϕd	ϕB
JIS 10K-80A	185	18	150	8	19	129.5	95
JIS 20K-80A	200	22	160	8	23		
JIS 30K-80A	210	26	170	8	23		
JIS 63K-80A	230	40	185	8	25		
ANSI 150-3B	190	24	152.4	4	19		
ANSI 300-3B	210	28.5	168.1	8	22		
ANSI 600-3B	210	32	168.1	8	22		
JPI 150-3B	190	24	152.4	4	19		
JPI 300-3B	210	28.5	168.1	8	22		
JPI 600-3B	210	32	168.1	8	22		

(Extended Diaphragm Flange)

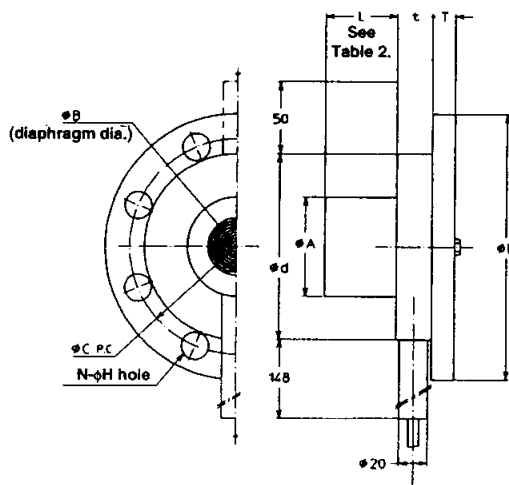

Table 1 Table of Flange Dimensions

Flange standard	ϕD	T	t	ϕC	N	ϕH	ϕd	ϕA	ϕB
JIS 10K-100A	210	18	23	175	8	19	95	95 ^{±1}	90
JIS 20K-100A	225	24		185	8	23			
JIS 30K-100A	240	32		195	8	25			
ANSI 150-4B	229	24		190.5	8	19			
ANSI 300-4B	254	32		200.2	8	22			
JPI 150-4B	229	24		190.5	8	19			
JPI 300-4B	254	32		200.2	8	22			

Table 2 Length of Extension

L
50
100
150
200
250
300

ST3000 Ace Smart Transmitter

JTE Series of Remote-sealed Type Differential Pressure Transmitters

JTE929A/JTE930A

General

The ST3000 Ace* Smart Transmitter is a microprocessor-based smart transmitter that features high performance and excellent stability. Capable of measuring gas, liquid, and vapor flow rates, and liquid levels, it transmits 4 to 20 mA dc analog and digital signals according to the measured differential pressure.

It can also execute two-way communications between the SFC (Smart Field Communicator), and, via DE protocol, with the TDCS3000 or 3000^x and a database, thus facilitating self-diagnosis, range resetting, and automatic zero adjustment.

Remote-sealed differential pressure transmitters are suitable for the measurement of differential pressures (flow rates, liquid levels, etc.) of process fluids that are highly corrosive, tend to condense, precipitate metal, etc.

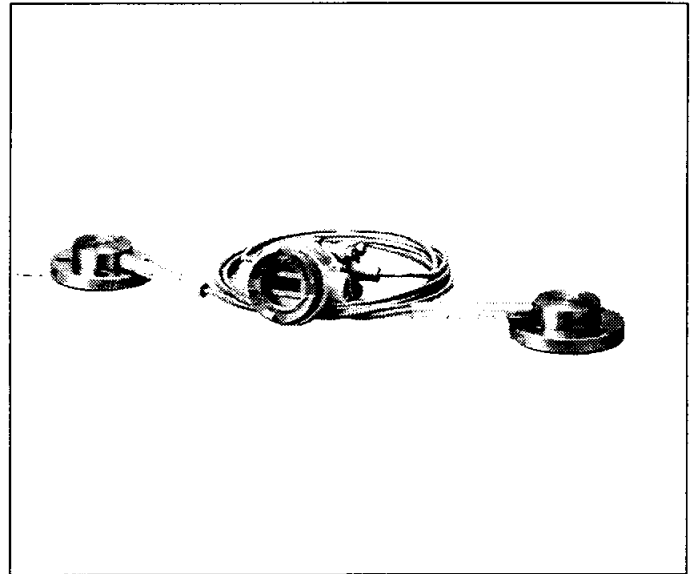

Features

- (1) Excellent stability and high performance
 - Long-term stability is proven in 500,000 installations worldwide.
 - Unique characterization and composite semiconductor sensors realize excellent temperature and static pressure characteristics.
- (2) A diverse lineup
 - A diverse flange lineup, ranging from small diameter 1.5B (40A) and 2B (50A) to 3B (80A), is available to meet user requirements.
 - A wide range of models, including those for general purposes and high-temperature service, is available to meet user requirements. In addition, the working temperature range of general purpose models has been expanded to 180°C maximum to allow you greater freedom in instrumentation.
 - A wide variety of corrosion-resistant materials for wetted parts is also available.
 - These differential pressure transmitters can be mounted in various ways, including direct mounting on tanks without using 2B stanchion pipes.
- (3) Function to correct the temperature of the fill fluid of the capillary section:
 - Changes in the density of the fill fluid caused by temperature fluctuations are calculated, and output is corrected accordingly. This function substantially reduces (to 1/5—1/10) the effect of seasonal fluctuations in temperature.
- (4) Multiprotocol communication
 - Either analog output (4 to 20 mA dc), analog FSK output (4 to 20 mA dc) or digital output (DE protocol) is possible.
 - Two-way communication using digital output facilitates self-diagnosis, range resetting, automatic zero adjustment, and other operations.

- (5) Full after-sales service program

- From product delivery to replacement, we service all your needs. Our nationwide service network provides all the backup you require, including trial operation support and regular maintenance.

Applications

Petroleum/Petrochemical/Chemical

- For the measurement of liquid levels including corrosive fluids at high temperatures, and high temperatures under vacuum
- For the control of flow rates as used with tapless venturi tubes
- For replacement of displacement type level gauges
- For materialization of instrumentation without connecting tubes

Electric Power/City Gas/Other Utilities

- For measurement applications that require high degrees of stability and accuracy

Pulp and Paper

- For lines that need transmitters resistant to chemical liquids, corrosive fluids and the like
- For the measurement of liquid levels in small tanks

Iron and Steel/Nonferrous Metal/Ceramics

- For lines that require stable measurement under strictly controlled (temperature, humidity, etc.) conditions

Machinery/Shipbuilding

- For lines that require stable measurement under strictly controlled (temperature, humidity, vibration, etc.) conditions

Specifications

Measuring span/setting range/working pressure range:

See Table 1.

Output/communication:

- Analog output (4 to 20 mA dc)
- Analog FSK output (4 to 20 mA dc)
(Frequency shift keying signal transmission system)
- Digital output (DE protocol)

Supply voltage and load resistance:

10.8 to 45 V dc. A load resistance of 250 Ω or more is necessary between loops. (See Figure 1)

Sealing liquid: Silicone oil for general purpose and high-temperature models

Fluorine oil for oxygen and chlorine models

For specific gravity, see Table 2.

Function to correct the temperature of the capillary section fill fluid : (Patent No.1978534)

Changes in the density of the fill fluid (ρ) caused by temperature fluctuations are calculated, and the output is corrected accordingly. This function substantially reduces the effect of seasonal fluctuations in temperature.

<How to set this function>

Set the inter-flange height L (m) according to the SFC. If the height L (m) is already known, let us know, so, this function can be set before shipment.

If the high pressure side (HP) of your transmitter is located under the tank, place a minus

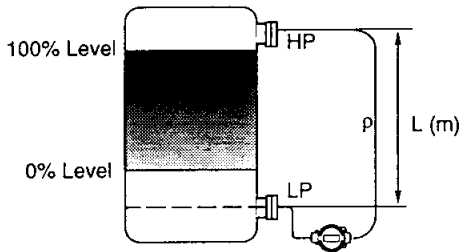

(-) sign before the height L setting.

Temperature ranges of wetted parts:

See Table 2.

Ambient temperature ranges:

See Table 2, except for explosion-proof models with digital indicators, which have to be used within the following ranges:

Models with digital indicators:

Normal operating conditions: -20 to 70°C

Operative limits: -30 to 80°C

JIS pressure-resistant special explosion-proof models: -20 to 60°C

JIS intrinsically safe explosion-proof models: -10 to 60°C

Ambient humidity range:

5 to 100% RH

Stability against supply voltage change:

±0.005% FS/V

Lightning protection:

Peak value of voltage surge: 100 kV

Peak value of current surge: 1000 A

Dead time:

Approx. 0.4 sec

Damping time constant:

Selectable from 0 to 32 sec in ten stages

Waterproof/dustproof structure:

JIS C0920 watertight: NEMA3 and 4X

JIS F8001 class 2 watertight: IEC IP67

Explosion-proof structure:

JIS special explosion-proof models: (Exds II CT4)

JIS intrinsically safe models: (i3aG4)

	Measuring Span	Setting Range	Working Pressure Range
JTE929A	2.5~100kPa (250~10160mmH ₂ O)	-100~100kPa (-10160~10160mmH ₂ O)	Up to the smaller value of either setting range or flange rating (For negative pressures, see Figures 2, 3, and 4.) (For flange rating, see "Max Working Pressure")
JTE930A	35~700kPa (10.35~7kgf/cm ²)	-100~700kPa (-1~7kgf/cm ²)	Up to the smaller value of either setting range or flange rating (For negative pressures, see Figures 2, 3, and 4.) (For flange rating, see "Max Working Pressure")

Table 1 Measuring Span, Setting Range, and Working Pressure Range

		Temperature Range (°C) Note 1), Note 4)		
		General-purpose models	High-temperature models	Oxygen and chlorine models
Wetted parts section	Normal operating range	-40~180	-5~280 Note 5)	-10~120
	Operative limit range	-50~185	-10~310 Note 6)	-40~125
Ambient temperature Note 2)	Normal operating range	-30~75	-5~55	-10~75
	Operative limit range	-50~80	-10~60	-40~80
Flange diameter: Flush diaphragm type 3B (80A) Extended diaphragm type 4B (100A)	Normal operating range	-15~65	-5~45	-10~75
	Operative limit range	-30~80	-10~55	-40~80
Specific gravity of fill liquid Note 3)		0.935	1.07	1.87

Table 2 Temperature Range of Wetted Parts Section and Ambient Temperature Range

- Note 1)
- Note 2)
- Note 3)
- Note 4)
- Note 5)
- Note 6)

See the working pressures and temperatures of the wetted parts section in Figure 2, Figure 3, and Figure 4.
Ambient temperatures of the transmitter itself
Approximate values at the temperature of 25°C
Note that if the operating temperature falls below the lower limit of the normal operating range, the response of the transmitter becomes slower.
When the wetted parts material is tantalum, the upper limit is 180°C.
When the wetted parts material is tantalum, the upper limit is 200°C.

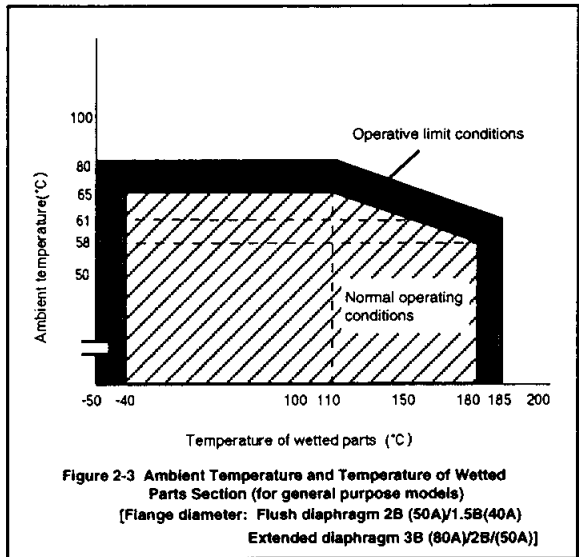
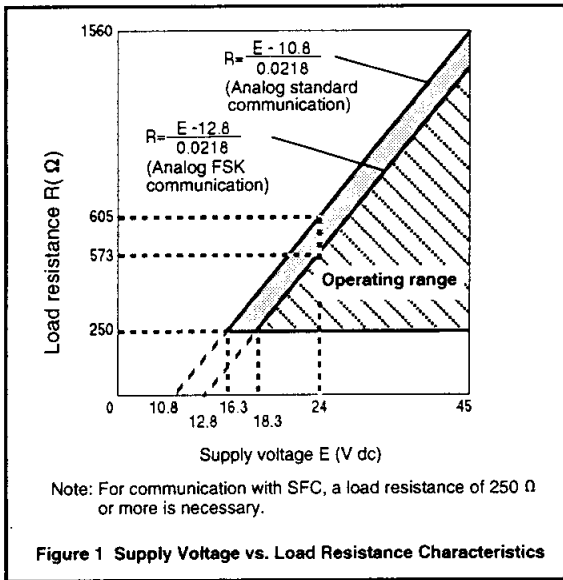

Note) When the fill liquid is for general purposes, make sure before using your transmitter that the conditions in both Figure 2-1, 2-2 and Figure 2-3 are met.

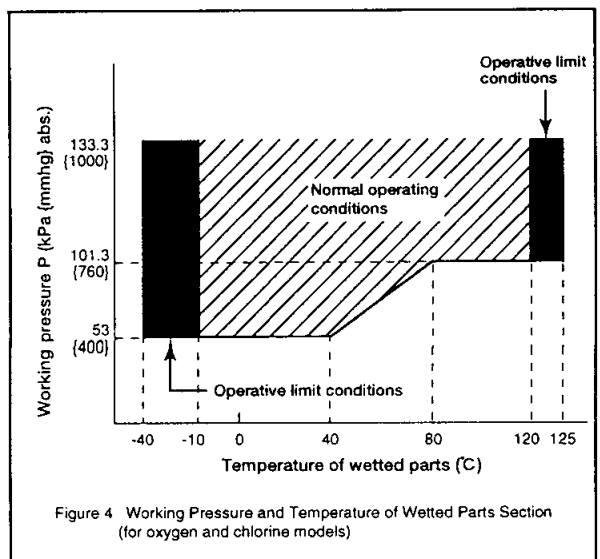
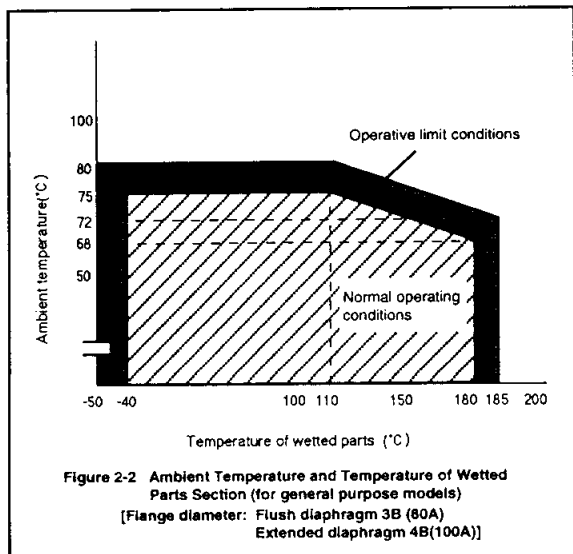
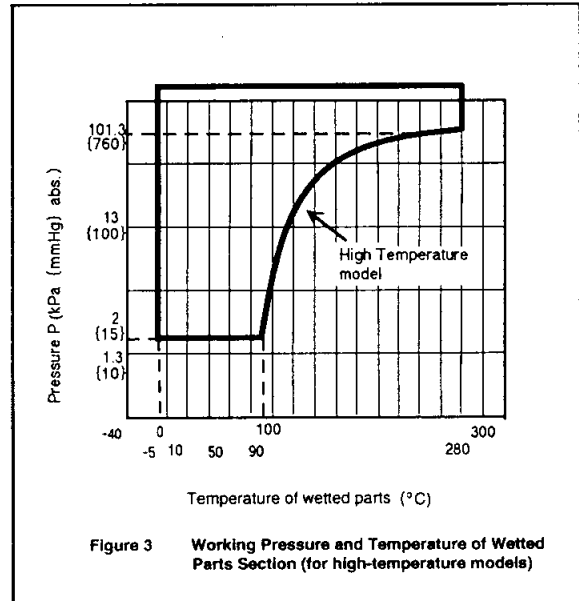
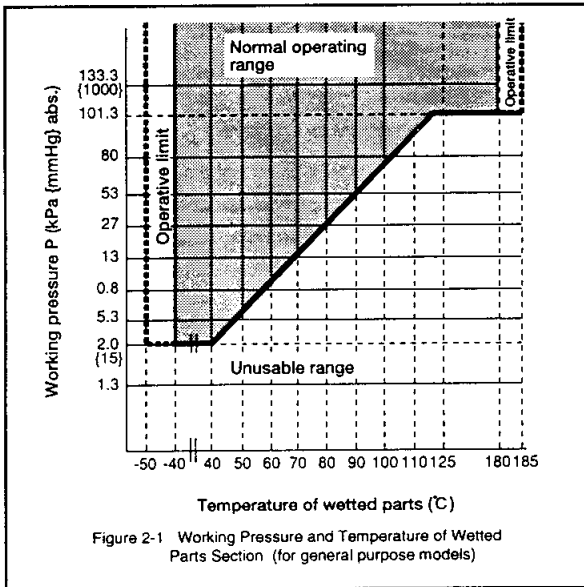

Max Working Pressure

<ForNewloc>

- Note1. Max Working Pressure depends on flange rating, flange materials and operating temperature. Please refer to the following data.
 Operating range of temperature depends on specification of transmitters
- Note2. In case of flange type (JTF940□, JTC940□) and remote sealed type (JTU940□, JTH940□),
 Max Working Pressure depends on the smaller value of either 1.5MPa or following data.
- Note3. In case of absolute remote sealed type (JTS940□),
 Max Working Pressure depends on the smaller value of either 3.5MPa abs or following data.
 As for the following data, the vertical axis represent gage pressure.
 Please exchange of units from gage pressure to absolute pressure, when you use.
- Note4. In case of remote sealed type (JTH960□), Max Working Pressure depends on the smaller value of either 10MPa or following data.
- Note5. In case of 1/2B remote sealed type (JTE929□, JTE930□, JTH960□),
 Max Working Pressure depends on the smaller value of either 5.1MPa or the following data as for adaptor flange (HF).

	JIS	JPI/ANSI
Carbon steel		
SUS304		
SUS316		
SUS316L		

Process pipe connection:

Flanges (both higher and lower pressure sides)

Flush diaphragm:

JIS10K, 20K, 30K, and 63K-80A/50A/40A (RF) equivalents

ANSI150, 300, and 600-3B/2B/1.5B (RF) equivalents

JPI150, 300, and 600-3B/2B/1.5B (RF) equivalents

Extended diaphragm:

JIS10K, 20K, and 30K-100A/80A/50A (RF) equivalents

ANSI150 and 300-4B/3B/2B (RF) equivalents

JPI150 and 300-4B/3B/2B (RF) equivalents

Electrical conduit connection:

G1/2 internal thread

1/2NPT internal thread (Not usable with JIS explosion-proof models)

Materials:

Center body: SUS316

Transmitter case: Aluminum alloy

Meter body cover: SUSF304

Wetted parts materials:

SUS316 (SUS316L for diaphragm only)

SUS316L

Hastelloy C, tantalum, etc.

Flange materials:

Carbon steel (SF440A), SUS304, SUS316, SUS316L

Bolts and nuts materials (for fastening meter body cover):

Carbon steel (SNB7), SUS630

Capillary section:

Capillary tube length: 2, 3, 4, 5, 6, 7, 8, 9, and 10 m

2, 3, 4, and 5 m when

flange diameters:

flush diaphragm 2B (50A)/1.5B (40A)

extended diaphragm 3B (80A)/2B (50A)

Capillary tube material: SUS316

Armored tube material: SUS304

Coating (optional): Olefin coating to improve corrosion resistance

Finish:

Housing: light beige (Munsell 4Y7.2/1.3)

Cap: dark beige (Munsell 10YR4.7/0.5)

Corrosion-resistant finish:

Standard: Corrosion-resistant paint (Baked acrylic paint)

Corrosion-resistant finish:

Corrosion-resistant paint (Baked acrylic paint), fungus-proof finish

Corrosion-proof finish:

Corrosion-proof paint (Baked epoxy paint), fungus-proof finish

Corrosion-resistant finish (silver paint):

Transmitter case is silver-painted in addition to the above corrosion-resistant finish.

Built-in indicating meter:

The digital LCD indicator (optional) indicates actual flow rates (in SI units) and can be set freely between -19999 and 19999 (4.5 digits). For actual calibration, specify the following items when placing your order:

- Actual calibration range
- Actual calibration unit
- Proportional representation and instructions about square-root extraction

Various kinds of data can be set using the SFC smart communicator (Ver. 7.1 or later).

Burnout feature:

Choice of three states at abnormal condition:

Burnout of output values: none

upper limit

lower limit

Grounding:

Class 3 grounding (grounding resistance 100 Ω max.)

Mounting:

Direct mounting on the process side

For mounting the transmitter body, choose between the following two methods:

- (1) Using 2-inch pipe mounting brackets: Mount the transmitter on a horizontal or vertical 2-inch pipe, then use the brackets.

Materials: Brackets: carbon steel

U bolts and nuts: SUS304

Mounting (continued):

- (2) Direct mounting (for general purpose model only)

Mounting Notes

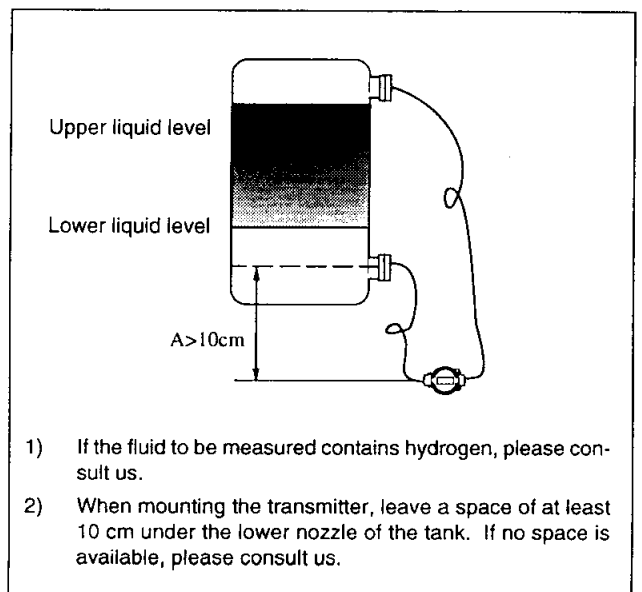

Mount the transmitter directly on the tank using the direct mounting kit supplied.

<Features>

- Direct mounting saves space.
- Capillary tubes can be neatly arranged using tube clamps. This also improves temperature characteristics.

Direct mounting kit (weight: approx. 600 g)

Component	Material
Adaptor	SUS13 (SUS304 equivalent)
Adaptor fastening bolt	SUS304 (M8)
Tube clamp	Brass + nickel plating

Weight: Approx. 19.8 kg
(including JIS10K-80A flange and capillary 5 m long)

Tank Level Setting by Direct Mounting Method

Notes)

- *1) When fitting a protective pipe upward as shown in the figure, be sure to specify a capillary tube with olefin coating. If a capillary tube without olefin coating is to be used, set the capillary withdrawal direction downward a little.
- *2) When bending a capillary tube, as shown in the figure, do not twist it. Also note that the minimum bending diameter is about 5 cm. Do not bend it more by applying excessive force.
- *3) Three tube clamps are supplied as an option. Referring to the figure, fix the tube at appropriate places. Do not tighten the clamps to the extent of deforming the tube.
- *4) Before zero adjusting using the SFC, be sure to set the inter-flange height L (m) and use the capillary fill fluid temperature correction function.

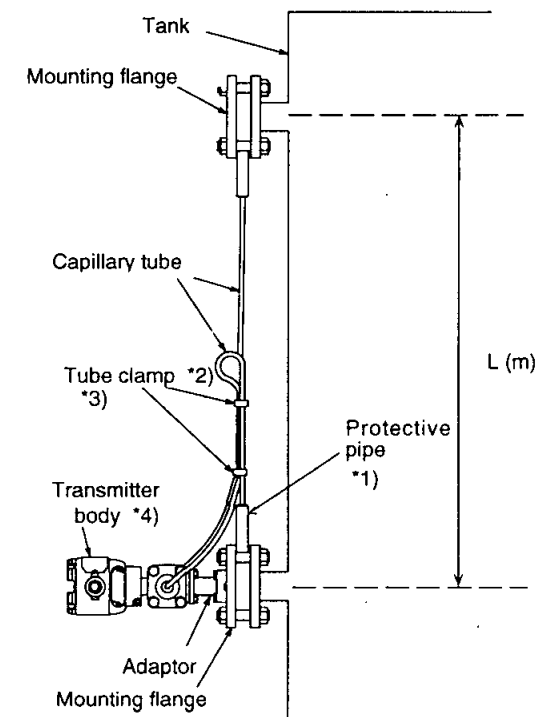

Optional Specifications

External zero adjustment function:

The transmitter can be easily zero-adjusted in the field with a flat-blade screwdriver.

Additional lightning protection:

It is possible to achieve a lightning protection performance of 200 kV, 2000 A, twice the standard performance (100 kV, 1000 A). This is advisable when the transmitter is to be used in lightning-prone areas such as mountains, hills and wherever high-performance lightning protection is required.

Elbow:

This is an adaptor for changing the electrical conduit connection port from the horizontal to the vertical direction, if required by wiring conditions in the field. One or two elbows may be used as needed.

Water inhibiting treatment (including oil inhibiting treatment):

The transmitter is shipped with dry and oil-free wetted parts.

Oil inhibiting treatment:

The transmitter is shipped with oil-free wetted parts. (The vent drain plug is coated with a small amount of fluorine oil to prevent galling.)

FEP protective film:

Use FEP protective films when corrosive fluids are used or to inhibit ion migration from metal diaphragms.

Working temperature range:

0 to 110°C

Working pressure range:

atmospheric pressure to flange rating

(up to JIS10K, ANSI/JPI150)

(Not usable under negative pressure)

Electric power specification:

This specification applies where stringent quality control is required, such as in the electric power and city gas industries.

Special burnout (3.2 mA):

The burnout output value (in the lower-limit direction) under abnormal conditions shall be 3.2 mA (-5%) or less.

Test report:

The test report indicates the results of appearance, I/O characteristics, insulation resistance, and breakdown voltage tests.

Mill sheet:

The mill sheet shows the chemical composition, heat-treatment conditions, and mechanical properties of the materials used for the wetted parts.

Documents of conformance to the High Pressure Gas Control Law (for general purposes):

This specification applies when documents verifying conformance to the High Pressure Gas Control Law are required. The documents consist of a strength calculation sheet, the mill sheet, and a pressure resistance and gas-tightness test result sheet.

Strength calculation sheet:

The strength calculation sheet indicates the strength of the meter body cover, flanges, bolts, etc.

Pressure resistance and gas-tightness tests (for general purposes):

The pressure resistance and gas-tightness test result sheet shows the results of a pressure resistance test (under water pressure for 10 minutes) performed on the wetted parts.

Traceability certificate:

This certificate consists of three parts: the transmitter's measurement control system configuration diagram, a calibration certificate, and a test report.

Conformance to non-SI units:

We deliver transmitters set to any non-SI unit you specify.

Transmitter Handling Notes

To make the most of the performance this transmitter can offer, please use it properly noting the points mentioned below. Before using it, please read the Instruction Manual.

Transmitter Installation Notes

Warning

- When installing the transmitter, ensure that gaskets do not protrude from connecting points into the process (such as adapter flange connection points and connecting pipes and flanges). Gasket protrusion may cause leaks and output errors.
- Do not use the transmitter outside its defined pressure, temperature, and connection specifications. A serious accident may otherwise occur due to damage and leaks.
- When performing wiring work in explosion-proof areas, follow the work method specified in the explosion-proof guidelines. In addition, when the wiring for an explosion-proof product is a pull-in pressure-resistant packing-cable, be sure to use a pressure-resistant packing-cable adapter certified by Yamatake-Honeywell.
- When conduits are used for connection, be sure to use conduit fittings certified by Yamatake-Honeywell.

Caution

- After installing the transmitter, do not step on it. Using it as a foothold or the like could make it collapse and cause injury.
- Be careful not to hit the glass indicator with tools etc. This could break the glass and cause injury.
- This transmitter is heavy. Wear safety shoes and take care when installing it.

Wiring Notes

Warning

- To avoid shocks, do not perform electrical wiring work with wet hands or with live wires.

Caution

- Do wiring work properly in conformance with the specifications. Wiring mistakes may result in breakdown.
- Use a power supply that conforms to the specifications. Use of an improper power supply may result in breakdown.

Performance

Shown for each item are the upper limit (URV) ⁽¹⁾ and the lower limit (LRV) ⁽²⁾ of the calibration range or the percentage ratio of the maximum value of the span to χ (kPa).

JTE929A (for general purpose and high-temperature models)

Material for Wetted Parts: SUS316

Flange diameter: Flush diaphragm 3B (80A) Extended diaphragm 4B (100A)

Accuracy	Linear output: $\pm 0.3\%$ ($\chi \geq 12.5\text{kPa}$ {1250mmH ₂ O}) $\pm (0.3 \times \frac{12.5}{\chi})\%$ ($\chi < 12.5\text{kPa}$ {1250mmH ₂ O}) Square-root output: When output is 50 to 100%: same as linear output When output is 7.1 to 50%: linear output $\times \frac{50}{\text{square-root output \%}}$ When output is less than 7.1%: dropout
Temperature characteristics (Shift from the set range) Change of 55°C	Zero shift: $\pm 0.75\%$ ($\chi \geq 25\text{kPa}$ {2500mmH ₂ O}) $\pm 0.75 \times \frac{25}{\chi}\%$ ($\chi < 25\text{kPa}$ {2500mmH ₂ O}) Combined shift: $\pm 1.6\%$ ($\chi \geq 25\text{kPa}$ {2500mmH ₂ O}) (including zero and span shifts) $\pm 1.6 \times \frac{25}{\chi}\%$ ($\chi < 25\text{kPa}$ {2500mmH ₂ O})
Static pressure effect (Shift with respect to setting range) Change of 7MPa {70kgf/cm²}	Zero shift: $\pm 0.75\%$ ($\chi \geq 25\text{kPa}$ {2500mmH ₂ O}) $\pm (0.75 \times \frac{25}{\chi})\%$ ($\chi < 25\text{kPa}$ {2500mmH ₂ O}) Combined shift: $\pm 1.00\%$ ($\chi \geq 25\text{kPa}$ {2500mmH ₂ O}) (including zero and span shifts) $\pm (1.00 \times \frac{25}{\chi})\%$ ($\chi < 25\text{kPa}$ {2500mmH ₂ O})

JTE930A (for general purpose and high-temperature models)

Material for Wetted Parts: SUS316

Flange diameter: Flush diaphragm 3B (80A) Extended diaphragm 4B (100A)

Accuracy ⁽³⁾	Linear output: $\pm 0.2\%$ ($\chi \geq 210\text{kPa}$ {2.1kgf/cm ² }) $\pm (0.05 + 0.15 \times \frac{210}{\chi})\%$ ($\chi < 210\text{kPa}$ {2.1kgf/cm ² }) Square-root output: When output is 50 to 100%: same as linear output When output is 7.1 to 50%: linear output $\times \frac{50}{\text{square-root output \%}}$ When output is less than 7.1%: dropout
Temperature characteristics (Shift from the set range) ⁽³⁾ Change of 55°C	Zero shift: $\pm (0.25 + 0.5 \times \frac{210}{\chi})\%$ Combined shift: $\pm 1.6\%$ ($\chi \geq 210\text{kPa}$ {2.1kgf/cm ² }) (including zero and span shifts) $\pm (1.0 + 0.6 \times \frac{210}{\chi})\%$ ($\chi < 210\text{kPa}$ {2.1kgf/cm ² })
Static pressure effect (Shift with respect to setting range) ⁽³⁾ Change of 7MPa {70kgf/cm²}	Zero shift: $\pm (0.75 \times \frac{700}{\chi})\%$ Combined shift: $\pm (1.00 \times \frac{700}{\chi})\%$

Notes) ⁽¹⁾: URV denotes the value for 100% (20 mA dc) output.

⁽²⁾: LRV denotes value for 0% (4 mA dc) output.

⁽³⁾: Within a range of URV ≥ 0 and LRV ≥ 0

JTE929A (for general purpose and high-temperature models)

Material for Wetted Parts: Hastelloy C, Tantalum

Flange Diameter: Flush diaphragm 3B (80A)

Accuracy	Linear output:	$\pm 0.4\%$ $\pm (0.4 \times \frac{12.5}{x})\%$	$(\chi \geq 12.5\text{kPa } \{1250\text{mmH}_2\text{O}\})$ $(\chi < 12.5\text{kPa } \{1250\text{mmH}_2\text{O}\})$
	Square-root output:	When output is 50 to 100%: same as the linear output When output is 7.1 to 50%: linear output $\times \frac{50}{\text{square-root output } \%}$ When output is less than 7.1%: dropout	
Temperature characteristics (Shift from the set range) Change of 30°C (Range from -5 to 55°C)	Zero shift:	$\pm 2.15\%$ $\pm 2.15 \times \frac{25}{x} \%$	$(\chi \geq 25\text{kPa } \{2500\text{mmH}_2\text{O}\})$ $(\chi < 25\text{kPa } \{2500\text{mmH}_2\text{O}\})$
	Combined shift: (including zero and span shifts)	$\pm 3.0\%$ $\pm 3.0 \times \frac{25}{x} \%$	$(\chi \geq 25\text{kPa } \{2500\text{mmH}_2\text{O}\})$ $(\chi < 25\text{kPa } \{2500\text{mmH}_2\text{O}\})$
Static pressure effect (Shift with respect to setting range) Change of 7MPa {70kgf/cm ² }	Zero shift:	$\pm 6.00\%$ $\pm (6.00 \times \frac{25}{x})\%$	$(\chi \geq 25\text{kPa } \{2500\text{mmH}_2\text{O}\})$ $(\chi < 25\text{kPa } \{2500\text{mmH}_2\text{O}\})$
	Combined shift: (including zero and span shifts)	$\pm 7.00\%$ $\pm (7.00 \times \frac{25}{x})\%$	$(\chi \geq 25\text{kPa } \{2500\text{mmH}_2\text{O}\})$ $(\chi < 25\text{kPa } \{2500\text{mmH}_2\text{O}\})$

JTE930A (for general purpose and high-temperature models)

Material for Wetted Parts: Hastelloy C, Tantalum

Flange Diameter: Flush diaphragm 3B (80A)

Accuracy ^(*)	Linear output:	$\pm 0.2\%$ $\pm (0.05 + 0.15 \times \frac{2.1}{x})\%$	$(\chi \geq 210\text{kPa } \{2.1\text{kgf/cm}^2\})$ $(\chi < 210\text{kPa } \{2.1\text{kgf/cm}^2\})$
	Square-root output:	When output is 50 to 100%: same as the linear output When output is 7.1 to 50%: linear output $\times \frac{50}{\text{square-root output } \%}$ When output is less than 7.1%: dropout	
Temperature characteristics (Shift from the set range) Change of 30°C ^(**) (Range from -5 to 55°C)	Zero shift:	$\pm (0.15 + 0.7 \times \frac{210}{x})\%$	
	Combined shift: (including zero and span shifts)	$\pm 1.75\%$ $\pm (1.00 + 0.75 \times \frac{210}{x})\%$	$(\chi \geq 210\text{kPa } \{2.1\text{kgf/cm}^2\})$ $(\chi < 210\text{kPa } \{2.1\text{kgf/cm}^2\})$
Static pressure effect (Shift with respect to setting range) ^(***) Change of 7MPa {70kgf/cm ² }	Zero shift:	$\pm (0.75 \times \frac{700}{x})\%$	
	Combined shift: (including zero and span shifts)	$\pm (1.00 \times \frac{700}{x})\%$	

Notes) ^(*): URV denotes the value for 100% (20 mA dc) output.

^(**): LRV denotes value for 0% (4 mA dc) output.

^(***): Within a range of URV ≥ 0 and LRV ≥ 0

JTE929A (for general purpose models)

Material for Wetted Parts: SUS316

Flange Diameter: Flush diaphragm 2B (50A)/1.5B (40A) Extended diaphragm 3B (80A)/2B (50A)

Accuracy	Linear output:	$\pm 0.3\%$ $\pm (0.3 \times \frac{12.5}{x})\%$	$(\chi \geq 12.5\text{kPa } \{1250\text{mmH}_2\text{O}\})$ $(\chi < 12.5\text{kPa } \{1250\text{mmH}_2\text{O}\})$
	Square-root output:	When output is 50 to 100%: same as the linear output When output is 7.1 to 50%: $\text{linear output} \times \frac{50}{\text{square-root output \%}}$ When output is less than 7.1%: dropout	
Temperature characteristics (Shift from the set range)	Zero shift:	$\pm 0.75\%$ $\pm 0.75 \times \frac{25}{x}\%$	$(\chi \geq 25\text{kPa } \{2500\text{mmH}_2\text{O}\})$ $(\chi < 25\text{kPa } \{2500\text{mmH}_2\text{O}\})$
	Change of 55°C	Combined shift: (including zero and span shifts)	$\pm 1.6\%$ $\pm 1.6 \times \frac{25}{x}\%$ $(\chi \geq 25\text{kPa } \{2500\text{mmH}_2\text{O}\})$ $(\chi < 25\text{kPa } \{2500\text{mmH}_2\text{O}\})$
Static pressure effect (Shift with respect to setting range)	Zero shift:	$\pm 1.47\%$ $\pm (1.47 \times \frac{25}{x})\%$	$(\chi \geq 25\text{kPa } \{2500\text{mmH}_2\text{O}\})$ $(\chi < 25\text{kPa } \{2500\text{mmH}_2\text{O}\})$
	Change of 7MPa (70kgf/cm²)	Combined shift: (including zero and span shifts)	$\pm 1.97\%$ $\pm (1.97 \times \frac{25}{x})\%$ $(\chi \geq 25\text{kPa } \{2500\text{mmH}_2\text{O}\})$ $(\chi < 25\text{kPa } \{2500\text{mmH}_2\text{O}\})$

JTE929A (for high-temperature models)

Material for Wetted Parts: SUS316

Flange Diameter: Flush diaphragm 2B (50A)/1.5B (40A) Extended diaphragm 3B (80A)/2B (50A)

Accuracy	Linear output:	$\pm 0.3\%$ $\pm (0.3 \times \frac{12.5}{x})\%$	$(\chi \geq 12.5\text{kPa } \{1250\text{mmH}_2\text{O}\})$ $(\chi < 12.5\text{kPa } \{1250\text{mmH}_2\text{O}\})$
	Square-root output:	When output is 50 to 100%: same as the linear output When output is 7.1 to 50%: $\text{linear output} \times \frac{50}{\text{square-root output \%}}$ When output is less than 7.1%: dropout	
Temperature characteristics (Shift from the set range)	Zero shift:	$\pm 0.36\%$ $\pm 0.36 \times \frac{25}{x}\%$	$(\chi \geq 25\text{kPa } \{2500\text{mmH}_2\text{O}\})$ $(\chi < 25\text{kPa } \{2500\text{mmH}_2\text{O}\})$
	Change of 10°C	Combined shift: (including zero and span shifts)	$\pm 2.18\%$ $\pm 2.18 \times \frac{25}{x}\%$ $(\chi \geq 25\text{kPa } \{2500\text{mmH}_2\text{O}\})$ $(\chi < 25\text{kPa } \{2500\text{mmH}_2\text{O}\})$
Static pressure effect (Shift with respect to setting range)	Zero shift:	$\pm 2.7\%$ $\pm (2.7 \times \frac{25}{x})\%$	$(\chi \geq 25\text{kPa } \{2500\text{mmH}_2\text{O}\})$ $(\chi < 25\text{kPa } \{2500\text{mmH}_2\text{O}\})$
	Change of 7MPa (70kgf/cm²)	Combined shift: (including zero and span shifts)	$\pm 3.5\%$ $\pm (3.5 \times \frac{25}{x})\%$ $(\chi \geq 25\text{kPa } \{2500\text{mmH}_2\text{O}\})$ $(\chi < 25\text{kPa } \{2500\text{mmH}_2\text{O}\})$

JTE930A (for general purpose and high-temperature models)

Material for Wetted Parts: SUS316

Flange Diameter: Flush diaphragm 2B (50A)/1.5B (40A) Extended diaphragm 3B (80A)/2B (50A)

Accuracy ^(*)	Linear output:	$\pm 0.2\%$ $\pm (0.05 + 0.5 \times \frac{210}{x})\%$	$(\chi \geq 210\text{kPa } \{2.1\text{kgf/cm}^2\})$ $(\chi < 210\text{kPa } \{2.1\text{kgf/cm}^2\})$
	Square-root output:	When output is 50 to 100%: same as the linear output When output is 7.1 to 50%: $\text{linear output} \times \frac{50}{\text{square-root output \%}}$ When output is less than 7.1%: dropout	
Temperature characteristics (Shift from the set range) ^(*)	Zero shift:	$\pm (0.25 + 0.15 \times \frac{210}{x})\%$	
	Change of 55°C	Combined shift: (including zero and span shifts)	$\pm 2.8\%$ $\pm (2.2 + 0.6 \times \frac{210}{x})\%$ $(\chi \geq 210\text{kPa } \{2.1\text{kgf/cm}^2\})$ $(\chi < 210\text{kPa } \{2.1\text{kgf/cm}^2\})$
Static pressure effect (Shift with respect to setting range) ^(*)	Zero shift:	$\pm \{ (\frac{T-25}{200} + 0.47) \times \frac{700}{x} + 0.03 \}\%$	
	Change of 7MPa (70kgf/cm²)	Combined shift:	$\pm \{ (\frac{T-25}{200} + 0.72) \times \frac{1400}{x} + 0.03 \}\%$ T: ambient temperature (°C)

JTE929A (for general purpose and high-temperature models)

Material for Wetted Parts: Hastelloy C, Tantalum

Flange Diameter: Flush diaphragm 2B (50A)/1.5B (40A)

Accuracy	<p>Linear output: $\pm 0.4\%$ ($\chi \geq 12.5\text{kPa}$ {1250mmH₂O}) $\pm (0.4 \times \frac{12.5}{\chi})\%$ ($\chi < 12.5\text{kPa}$ {1250mmH₂O})</p> <p>Square-root output: When output is 50 to 100%: same as the linear output When output is 7.1 to 50%: linear output $\times \frac{50}{\text{square-root output \%}}$ When output is less than 7.1%: dropout</p>
Temperature characteristics (Shift from the set range) Change of 30°C (Range from -5 to 55°C)	<p>Zero shift: $\pm 2.15\%$ ($\chi \geq 25\text{kPa}$ {2500mmH₂O}) $\pm 2.15 \times \frac{25}{\chi}\%$ ($\chi < 25\text{kPa}$ {2500mmH₂O})</p> <p>Combined shift: (including zero and span shifts) $\pm 6.55\%$ ($\chi \geq 25\text{kPa}$ {2500mmH₂O}) $\pm 6.55 \times \frac{25}{\chi}\%$ ($\chi < 25\text{kPa}$ {2500mmH₂O})</p>
Static pressure effect (Shift with respect to setting range) Change of 7MPa {70kgf/cm ² }	<p>Zero shift: $\pm 6.00\%$ ($\chi \geq 25\text{kPa}$ {2500mmH₂O}) $\pm (6.00 \times \frac{25}{\chi})\%$ ($\chi < 25\text{kPa}$ {2500mmH₂O})</p> <p>Combined shift: (including zero and span shifts) $\pm 7.00\%$ ($\chi \geq 25\text{kPa}$ {2500mmH₂O}) $\pm (7.00 \times \frac{25}{\chi})\%$ ($\chi < 25\text{kPa}$ {2500mmH₂O})</p>

JTE930A (for general purpose and high-temperature models)

Material for Wetted Parts: Hastelloy C, Tantalum

Flange Diameter: Flush diaphragm 2B (50A)/1.5B (40A)

Accuracy ⁽¹⁾	<p>Linear output: $\pm 0.2\%$ ($\chi \geq 210\text{kPa}$ {2.1kgf/cm²}) $\pm (0.05 + 0.15 \times \frac{2.1}{\chi})\%$ ($\chi < 210\text{kPa}$ {2.1kgf/cm²})</p> <p>Square-root output: When output is 50 to 100%: same as the linear output When output is 7.1 to 50%: linear output $\times \frac{50}{\text{square-root output \%}}$ When output is less than 7.1%: dropout</p>
Temperature characteristics (Shift from the set range) Change of 30°C ⁽²⁾ (Range from -5 to 55°C)	<p>Zero shift: $\pm (0.15 + 0.7 \times \frac{210}{\chi})\%$</p> <p>Combined shift: (including zero and span shifts) $\pm 3.0\%$ ($\chi \geq 210\text{kPa}$ {2.1kgf/cm²}) $\pm (2.2 + 0.8 \times \frac{210}{\chi})\%$ ($\chi < 210\text{kPa}$ {2.1kgf/cm²})</p>
Static pressure effect (Shift with respect to setting range) ⁽³⁾ Change of 7MPa {70kgf/cm ² }	<p>Zero shift: $\pm \{ (\frac{T-25}{200} + 0.47) \times \frac{700}{\chi} + 0.03 \}\%$</p> <p>Combined shift: (including zero and span shifts) $\pm \{ (\frac{T-25}{200} + 0.72) \times \frac{1400}{\chi} + 0.03 \}\%$</p> <p style="text-align: right;">T: ambient temperature (°C)</p>

Notes) ⁽¹⁾: URV denotes the value for 100% (20 mA dc) output.

⁽²⁾: LRV denotes value for 0% (4 mA dc) output.

⁽³⁾: Within a range of URV ≥ 0 and LRV ≥ 0

Model Number Configuration Table

**ST3000 Ace Remote-Sealed Differential Pressure Transmitter (JTE) with Flush Diaphragm Flange 3B (80A)
for General Purpose and High-Temperature Models**

	Basic model number	Selections	Optional selections	Options
Measuring span	2.5~100kPa 35~700kPa	J T E 9 2 9 A J T E 9 3 0 A		
Forms of output/communication	4 to 20 mA dc (analog standard communication) 4 to 20 mA dc (analog FSK communication) DE output	1 2 3		
Wetted parts material	SUS316 (diaphragm: SUS316L) Tantalum Hastelloy C SUS316L	2 4 H 8		
Sealing liquid	For general purposes: silicone oil For oxygen service: fluorine oil For high-temperature model: silicone oil (Note 1) For chlorine service: fluorine oil	1 2 3 5		
Flange standard	JIS10K JIS20K JIS30K JIS63K ANSI150 ANSI300 ANSI600 JPI150 JPI300 JPI600	A C D F G H J N P Q		
Flange diameter	3 B / 80 A	2		
Flange shape	Standard	1		
Flange material/ Bolt/nut material	Carbon steel/Carbon steel Carbon steel/SUS304 Carbon steel/SUS630 SUS304/Carbon steel SUS304/SUS304 SUS304/SUS630 SUS316/Carbon steel SUS316/SUS304 SUS316/SUS630 SUS316L/Carbon steel SUS316/SUS304 SUS316L/SUS630	A B C D E F G H J K L M		
Capillary length	2 m 3 m 4 m 5 m 6 m 7 m 8 m 9 m 10 m 2 m (Olefin covering) 3 m (Olefin covering) 4 m (Olefin covering) 5 m (Olefin covering) 6 m (Olefin covering) 7 m (Olefin covering) 8 m (Olefin covering) 9 m (Olefin covering) 10 m (Olefin covering)	2 3 4 5 6 7 8 9 A B C H D J E F K G		
			X 1 H 2 3 6 A □	X X No optional specifications A 2 External zero adjustment A 4 Additional lightning protection B 7 For special local field meter G 1 One elbow (left) G 2 One elbow (right) G 3 Two elbows D 1 Water inhibiting treatment (including oil inhibition) D 2 Oil inhibition D 3 FEP protective film J 2 Power specifications J 8 Special burnout (3.2 mA) T 1 Test report T 2 Mill sheet T 3 Document conforming to High Pressure Gas Control Law (for general purposes) T 5 Strength calculation sheet T 6 Pressure resistance/gas-tightness test (for general purposes) T 8 Traceability certificate U 2 Non-SI unit conformance <input type="checkbox"/> Other
			X 1 H 2 3 6 A □	X Electrical conduit and explosion-proof status G1/2, not explosion-proof G1/2, JIS explosion-proof, with single standard conduit fittings G1/2, JIS explosion-proof, with double standard conduit fittings G1/2, JIS explosion-proof, with single standard packing G1/2, JIS explosion-proof, with double standard packing G1/2, JIS intrinsically safe 1/2 NPT, not explosion-proof Other
			X 1 2	X Indicator No meter Digital meter with standard reading (0 to 100%) Digital meter with actual reading
			X A B D	X Anticorrosion treatment Standard coating Anticorrosion treatment Heavy-duty anticorrosion treatment Silver anticorrosion treatment
			X x U D	X Flange processing None (Standard: JISRa3.2 (12.5 S)) x Burnout feature None Upper limit of output at abnormal condition Lower limit of output at abnormal condition
			X 1 P □	X Mounting bracket None Carbon steel (mounted on 2B pipe) Direct mounting (general purpose model only) Other

Note) The temperature range of tantalum wetted parts is -10 to 180°C.

ST3000 Ace Remote-Sealed Differential Pressure Transmitter (JTE) with Flush Diaphragm Flange 2B (50A)/ 1.5B (40A) for General Purpose and High-Temperature Models

Basic model number		Selections				Optional selections				Options
Measuring span	2.5~100kPa 35~700kPa	JTE929A JTE930A								X X No optional specifications
Forms of output/communication	4 to 20 mA dc (analog standard communication) 4 to 20mA dc (analog FSK communication) DE output	1 2 3								A 2 External zero adjustment A 4 Additional lightning protection B 7 For special local field meter G 1 One elbow (left) G 2 One elbow (right) G 3 Two elbows
Wetted parts material	SUS316 (diaphragm: SUS316L) Tantalum Note 1) Hastelloy C SUS316L	2 4 H 8								D 1 Water inhibiting treatment (including oil inhibition) D 2 Oil inhibition D 3 FEP protective film J 2 Power specifications J 8 Special burnout (3.2 mA) T 1 Test report T 2 Mill sheet T 3 Document conforming to High Pressure Gas Control Law (for general purposes) T 5 Strength calculation sheet T 6 Pressure resistance/gas-tightness test (for general purposes) T 8 Traceability certificate U 2 Non-SI unit conformance <input type="checkbox"/> Other
Sealing liquid	For general purposes: silicone oil For oxygen service: fluorine oil For high-temperature model: silicone oil For chlorine service: fluorine oil	1 2 3 5								
Flange standard	JIS10K JIS20K JIS30K JIS63K ANSI150 ANSI300 ANSI600 JPI150 JPI300 JPI600	A C D F G H J N P Q								
Flange diameter	2 B / 50A 1.5 B / 40A	3 4								
Flange shape	Standard	1								
Flange material/ Bol/nut material	Carbon steel/Carbon steel Carbon steel/SUS304 Carbon steel/SUS630 SUS304/Carbon steel SUS304/SUS304 SUS304/SUS630 SUS316/Carbon steel SUS316/SUS304 SUS316/SUS630 SUS316L/Carbon steel SUS316L/SUS304 SUS316L/SUS630	A B C D E F G H J K L M								X Electrical conduit and explosion-proof status G1/2, not explosion-proof G1/2, JIS explosion-proof, with single standard conduit fittings G1/2, JIS explosion-proof, with double standard conduit fittings G1/2, JIS explosion-proof, with single standard packing G1/2, JIS explosion-proof, with double standard packing G1/2, JIS intrinsically safe 1/2 NPT, not explosion-proof Other
Capillary length	2 m 3 m 4 m 5 m 2 m (Olefin covering) 3 m (Olefin covering) 4 m (Olefin covering) 5 m (Olefin covering)	2 3 4 5 B C H D								X Indicator 1 Digital meter with standard reading (0 to 100%) 2 Digital meter with actual reading X Anticorrosion treatment A Standard coating B Anticorrosion treatment D Heavy-duty anticorrosion treatment Silver anticorrosion treatment X Flange processing None (Standard: JISRa3.2 (12.5 S)) X Burnout feature U Upper limit of output at abnormal condition D Lower limit of output at abnormal condition X Mounting bracket 1 Carbon steel (mounted on 2B pipe) P Direct mounting (general purpose model only) <input type="checkbox"/> Other

Note) When the wetted parts material is tantalum, the flange diameter is 2B (50A).

**ST3000 Ace Remote-Sealed Differential Pressure Transmitter (JTE) with Extended Diaphragm
Flange 3B (80A)/2B (50A) for General Purpose and High-Temperature Models**

Basic model number		Selections			Optional selections			Options		
Measuring span	2.5~100kPa	J	T	E	9	2	9	A		
	35~700kPa	J	T	E	9	3	0	A		
Forms of output/communication	4 to 20 mA dc (analog standard communication)	1								
	4 to 20 mA dc (analog FSK communication)	2								
	DE output	3								
material	SUS316 (diaphragm: SUS316L)	2								
Sealing liquid	For general purposes: silicone oil	1								
	For oxygen service: fluorine oil	2								
	For high-temperature model: silicone oil	3								
Flange standard	JIS10K				A					
	JIS20K				C					
	JIS30K				D					
	ANSI150				G					
	ANSI300				H					
	JPI150				N					
	JPI300				P					
Flange diameter	3 B / 80 A				2					
	2 B / 50 A				3					
Flange shape	Length of extension 50mm				2					
	Length of extension 100mm				3					
	Length of extension 150mm				4					
Flange material/ Bolt/nut material	Carbon steel / Carbon steel							A		
	Carbon steel / SUS304							B		
	Carbon steel / SUS630							C		
	SUS304 / Carbon steel							D		
	SUS304 / SUS304							E		
	SUS304 / SUS630							F		
	SUS316 / Carbon steel							G		
	SUS316 / SUS304							H		
	SUS316 / SUS630							J		
	SUS316L / Carbon steel							K		
SUS316L / SUS304							N			
SUS316L / SUS630							M			
Capillary length	2 m							2		
	3 m							3		
	4 m							4		
	5 m							5		
	2 m (Olefin covering)							B		
	3 m (Olefin covering)							C		
	4 m (Olefin covering)							H		
	5 m (Olefin covering)							D		
	X	Electrical conduit and explosion-proof status							G1/2, not explosion-proof	
	1								G1/2, JIS explosion-proof, with single standard conduit fittings	
H								G1/2, JIS explosion-proof, with double standard conduit fittings		
2								G1/2, JIS explosion-proof, with single standard packing		
3								G1/2, JIS explosion-proof, with double standard packing		
6								G1/2, JIS intrinsically safe		
A								1/2 NPT, not explosion-proof		
<input type="checkbox"/>								Other		
X	Indicator							No meter		
1								Digital meter with standard reading (0 to 100%)		
2								Digital meter with actual reading		
X	Anticorrosion treatment							Standard coating		
A								Anticorrosion treatment		
B								Heavy-duty anticorrosion treatment		
D								Silver anticorrosion treatment		
X	Flange processing							None (Standard: JISRa3.2 (12.5S))		
X	Burnout feature							None		
U								Upper limit of output at abnormal condition		
D								Lower limit of output at abnormal condition		
X	Mounting bracket							None		
1								Carbon steel (mounted on 2B pipe)		
P								Direct mounting (general purpose model only)		
<input type="checkbox"/>								Other		

Dimensions

(Unit: mm)

JTE929A/930A General Purpose and High-Temperature Models

Extended Diaphragm Flange

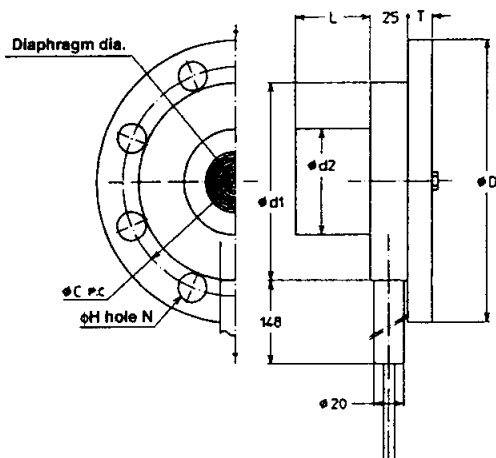

Flush Diaphragm Type Flange

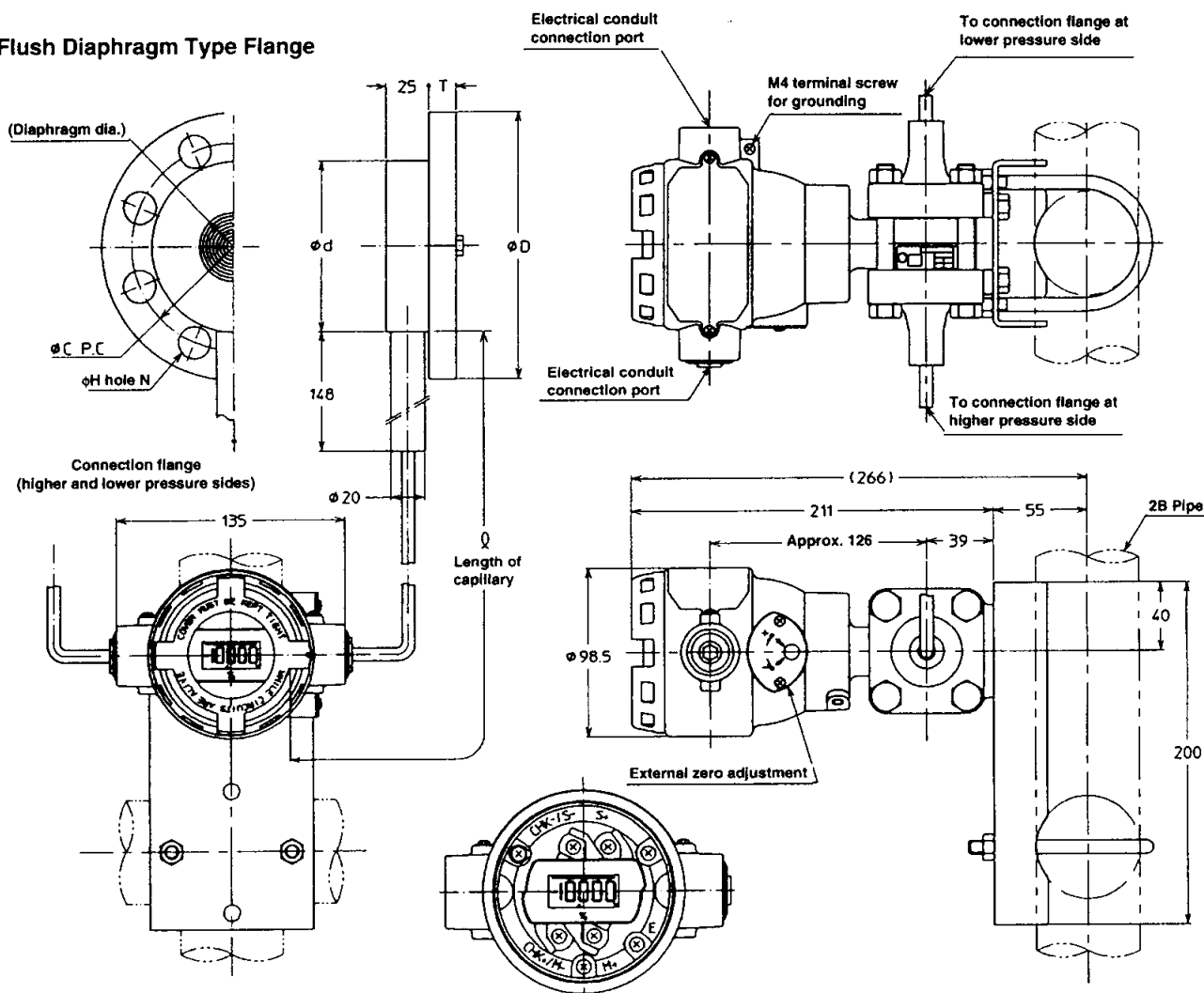

Notes)

1. The transmitter can be mounted in various ways by changing the position of the mounting bracket. (A typical example is shown in the figure.)
2. To prevent vibration, you are recommended to fasten the capillary tube mid-length.
3. Select a gasket that will not contact the diaphragm after it is tightened.
4. When the volume of suppression is larger than one half of the adjustment span, the higher pressure side and the lower pressure side of the process connection end flange are opposite to those shown in the figure. When using the transmitter to measure liquid levels, connect at H and L marks on the meter body as shown in the figure.

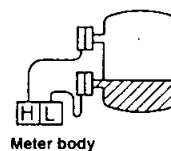

JTE929A/930A Table of Flush Diaphragm Flange Dimensions

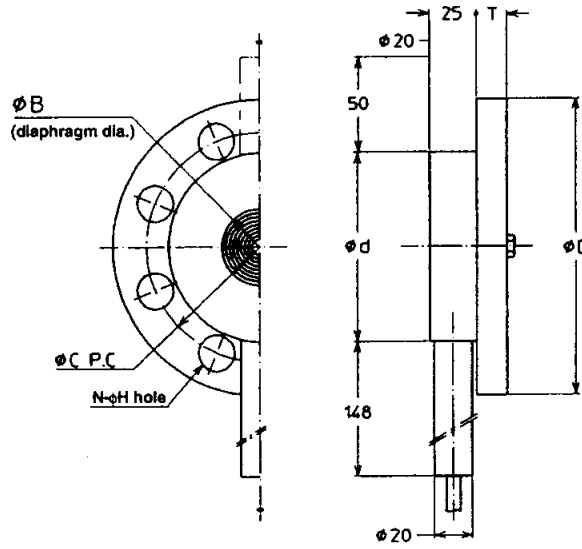

Table of Flange Dimension

Flange standard	ϕD	T	ϕC	N	ϕH	ϕd	ϕB
JIS 10K-40A	140	16	105	4	19	81	43
JIS 20K-40A	140	18	105	4	19		
JIS 30K-40A	160	22	120	4	23		
JIS 63K-40A	175	32	130	4	25		
ANSI 150 1-1/2B	127	18	98.6	4	16		
ANSI 3001-1/2B	155	21	114.3	4	22		
ANSI 600 1-1/2B	155	22.5	114.3	4	22		
JPI 150 1-1/2B	127	18	98.6	4	16		
JPI 3001-1/2B	155	21	114.3	4	22		
JPI 600 1-1/2B	155	22.5	114.3	4	22		
JIS 10K-50A	155	16	120	4	19	99	62 Note)
JIS 20K-50A	155	18	120	8	19		
JIS 30K-50A	165	22	130	8	19		
JIS 63K-50A	185	34	145	8	23		
ANSI 150-2B	152	19.5	120.6	4	19		
ANSI 300-2B	165	22.5	127	8	19		
ANSI 600-2B	165	25.5	127	8	19		
JPI 150-2B	152	19.5	120.6	4	19		
JPI 300-2B	165	22.5	127	8	19		
JPI 600-2B	165	25.5	127	8	19		
JIS 10K-80A	185	18	150	8	19	129.5	95
JIS 20K-80A	200	22	160	8	23		
JIS 30K-80A	210	28	170	8	23		
JIS 63K-80A	230	40	185	8	25		
ANSI 150-3B	190	24	152.4	4	19		
ANSI 300-3B	210	28.5	168.1	8	22		
ANSI 600-3B	210	32	168.1	8	22		
JPI 150-3B	190	24	152.4	4	19		
JPI 300-3B	210	28.5	168.1	8	22		
JPI 600-3B	210	32	168.1	8	22		

Note) Material for hastelloy C wetted parts: $\phi B=43$

JTE929A/930A Table of Extended Diaphragm Flange Dimensions

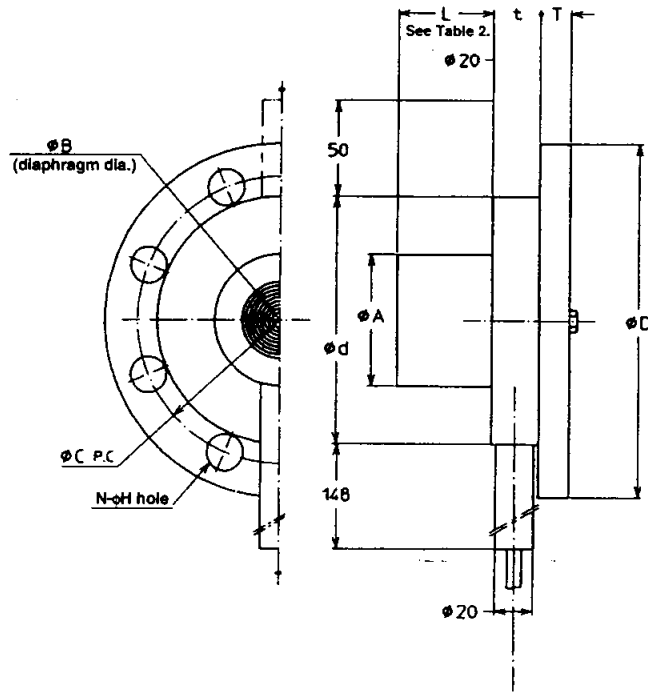
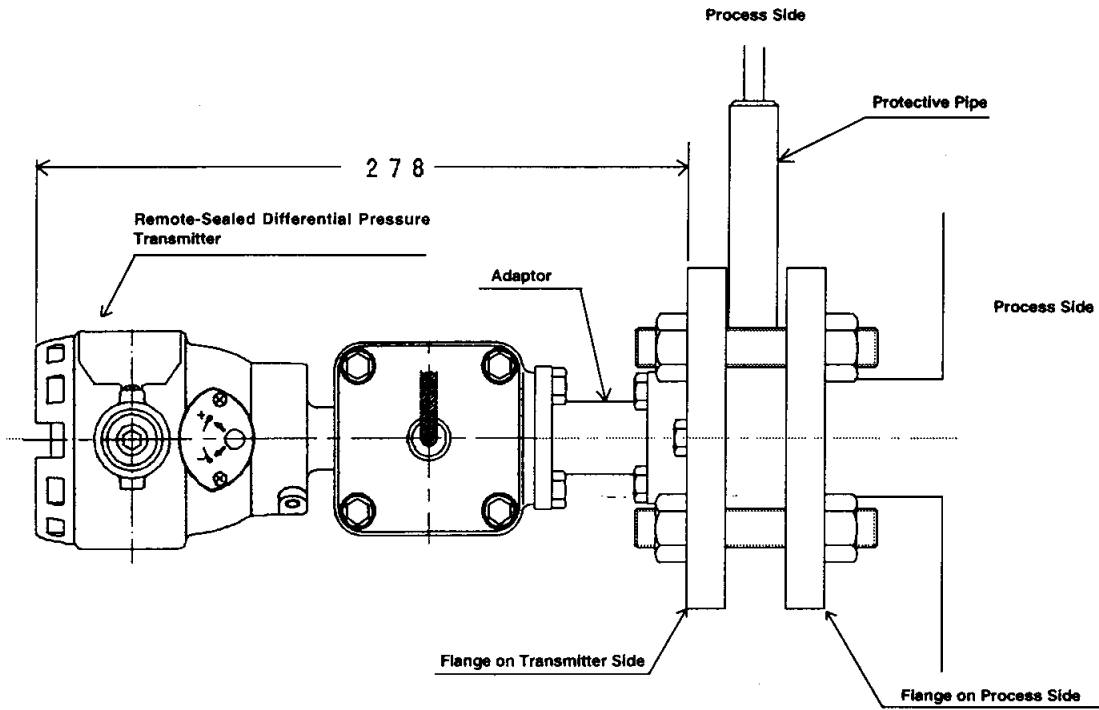

Table 1 Table of Flange Dimension

Flange standard	ϕD	T	t	ϕC	N	ϕH	ϕd	ϕA	ϕB
JIS 10K-100A	210	18	23	175	8	19	157	95 \pm 1	90
JIS 20K-100A	225	24		185	8	23			
JIS 30K-100A	240	32		195	8	25			
ANSI 150-4B	229	24		190.5	8	19			
ANSI 300-4B	254	32		200.2	8	22			
JPI 150-4B	229	24		190.5	8	19			
JPI 300-4B	254	32		200.2	8	22			
JIS 10K-80A	185	18	25	150	8	19	129.5	69 \pm 1	62
JIS 20K-80A	200	22		160	8	23			
JIS 30K-80A	210	28		170	8	23			
JIS 63K-80A	230	40		185	8	25			
ANSI 150-3B	190	24		152.4	4	19			
ANSI 300-3B	210	28.5		168.1	8	22			
ANSI 600-3B	210	32		168.1	8	22			
JPI 150-3B	190	24		152.4	4	19			
JPI 300-3B	210	28.5		168.1	8	22			
JPI 600-3B	210	32		168.1	8	22			
JIS 10K-50A	155	16		25	120	4			
JIS 20K-50A	155	18	120		8	19			
JIS 30K-50A	165	22	130		8	19			
JIS 63K-50A	185	34	145		8	23			
ANSI 150-2B	152	19.5	120.6		4	19			
ANSI 300-2B	165	22.5	127		8	19			
ANSI 600-2B	165	25.5	127		8	19			
JPI 150-2B	152	19.5	120.6		4	19			
JPI 300-2B	165	22.5	127		8	19			
JPI 600-2B	165	25.5	127		8	19			

Table 2 Length of Extension

L
50
100
150
200
250
300



Adaptor Assembly Drawing (JTE Type + Adaptor)

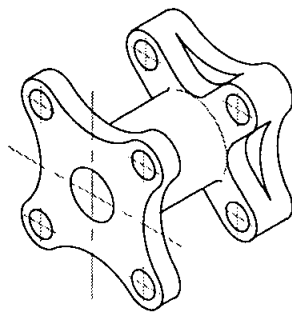

Adaptor Outline Drawing

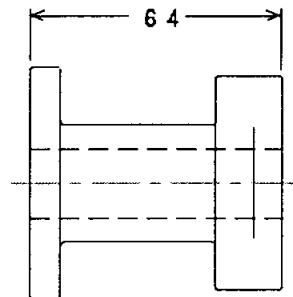

Adaptor Dimension Drawing

ST3000 Ace Smart Transmitter 1/2B Remote-Sealed Transmitters

JTE929A/JTE930A

JTH940A/JTH960A

General

The ST3000 Ace[®] Smart Transmitter is a microprocessor-based smart transmitter that features high performance and excellent stability. Capable of measuring gas, liquid, and vapor flow rates, and liquid levels, it transmits 4 to 20 mA dc analog and digital signals according to the measured differential pressure.

It can also execute two-way communications between the SFC (Smart Field Communicator), and, via DE protocol, with the TDCS3000 or 3000[®] and a database, thus facilitating self-diagnosis, range resetting, and automatic zero adjustment.

Remote-sealed transmitters are suitable for the measurement of differential pressures (flow rates, liquid levels, etc.) of process fluids that are highly corrosive, tend to condense, precipitate metal, etc.

In addition, connecting tubes are made unnecessary by connecting a 1/2B or 3/4B flange directly to the pressure tap. It prevents troubles that could otherwise be caused by clogging or staining and reduces costs associated with steam tracing, tube connecting, and other work.

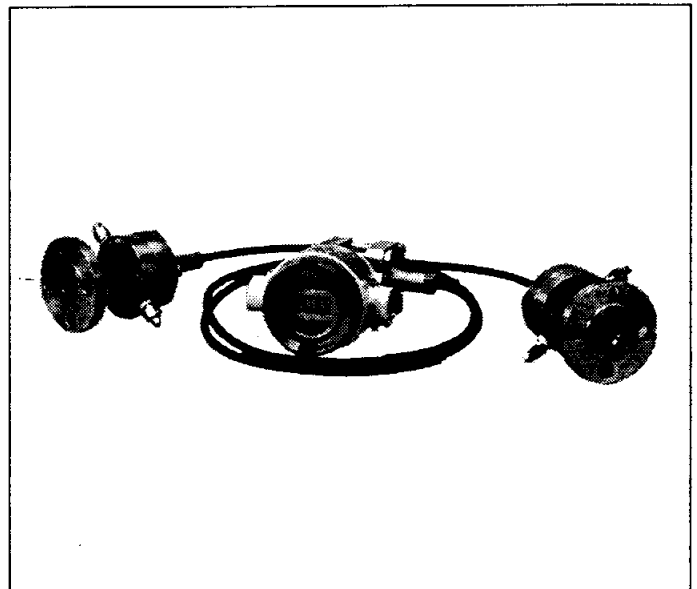

Features

- (1) Tubeless instrumentation
 - Connecting tubes are made unnecessary by connecting a 1/2B or 3/4B flange directly to the pressure tap. This prevents troubles that could be caused by clogging, stains, leaks, aging, etc.
- (2) Substantial labor cost reductions
 - Substantial cost and labor reductions compared to using connecting tubes and steam tracing.
- (3) Considerable maintenance cost reductions
 - No need to change or replenish the sealing liquid.
 - No need to remove connecting tube clogging.
 - No need to zero point adjust.
- (4) Substantial reductions in dangerous work
 - No need to do the dangerous work of checking connecting tubes for leaks.
 - No need to do the dangerous work of removing clogging from connecting tubes.
 - No need to do the dangerous work of changing or replenishing the sealing liquid.
- (5) A diverse lineup
 - A diverse lineup, ranging from the small diameter flanges of 1/2B (15A) and 3/4B (20A) to screw-in flanges, is available to meet user requirements.
- (6) Excellent stability and high performance
 - Long-term stability is proven in 500,000 installations worldwide.
 - Unique characterization and composite semiconductor sensors realize excellent temperature and static pressure characteristics.
- (7) Function to correct the temperature of the capillary section fill fluid (JTE type only):
 - Changes in the density of the fill fluid caused by temperature fluctuations are calculated, and the output is corrected accordingly. This function substantially reduces (to 1/5—1/10) the effect of seasonal fluctuations in temperature.

Applications

- For the measurement of fluids that tend to clog up connecting tubes
- For the measurement of liquid levels and pressures in small tanks
- For the measurement of liquids that otherwise demands laborious heat insulation work
- For the measurement of differential pressure flow rates (Consult us separately)
- For applications where laborious work such as replenishing the sealing liquid would otherwise be required.
- For the replacement of displacement level gages

Specifications

Measuring span/setting range/working pressure range:

See Table 1.

Output/communication:

Analog output (4 to 20 mA dc)
 Analog FSK output (4 to 20 mA dc)
 (Frequency shift keying signal transmission system)
 Digital output (DE protocol)

Supply voltage and load resistance:

10.8 to 45 V dc. A load resistance of 250 Ω or more is necessary between loops. (See Figure 1)

Sealing liquid: Silicone oil for general purpose and high-temperature models

Fluorine oil for oxygen models
 For specific gravity, see Table 2.

Function to correct the temperature of the capillary section fill fluid (JTE type only): (Patent No.1973584)

Changes in the density of the fill fluid (ρ) caused by temperature fluctuations are calculated, and the output is corrected accordingly. This function substantially reduces the effect of seasonal fluctuations in temperature.

<How to set this function>

Set the inter-flange height L (m) according to the SFC. If the height L (m) is already known, let us know, so, this function can be set before shipment.

If the high pressure side (HP) of your transmitter is to be located under the tank, place a minus (-) sign before the height L setting.

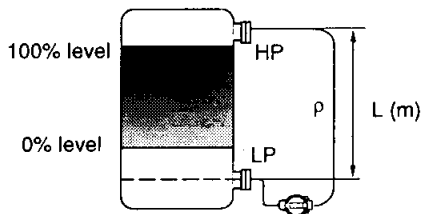

	Measuring Span	Setting Range	Working Pressure Range
JTE929A	2.5~100kPa {250~10160mmH ₂ O}	-100~100kPa {-10160~10160mmH ₂ O}	Up to the smaller value of either setting range or flange rating (For negative pressures, see Figures 2, 3, and 4.) (For flange rating, see "Max Working Pressure")
JTE930A	35~700kPa {0.35~7kgf/cm ² }	-100~700kPa {-1~7kgf/cm ² }	Up to the smaller value of either setting range or flange rating (For negative pressures, see Figures 2, 3, and 4.) (For flange rating, see "Max Working Pressure")
JTH940A	35~3500kPa {0.35~35kgf/cm ² }	-100~3500kPa {-1~35kgf/cm ² }	Up to the smaller value of either setting range or flange rating (For negative pressures, see Figures 2, 3, and 4.) (For flange rating, see "Max Working Pressure")
JTH960A	0.7~10MPa {7~102kgf/cm ² }	-0.1~10kPa {-1~102kgf/cm ² }	Up to the smaller value of either setting range or flange rating (For negative pressures, see Figures 2, 3, and 4.) (For flange rating, see "Max Working Pressure")

Table 1 Measuring Span, Setting Range, and Working Pressure Range

		Temperature Range (°C) Note 1), Note 4)		
		General-purpose models	High-temp. models	Oxygen models
Wetted parts section	Normal operating range	-40~180	-5~280	-10~120
	Operative limit range	-50~185	-10~310	-40~125
Ambient temperature Note 2)	Normal operating range	-15~65	-5~45	-10~75
	Operative limit range	-30~80	-10~55	-40~80
Specific gravity of fill liquid Note 3)		0.935	1.07	1.87

Note 1) See the working pressures and temperatures of the wetted parts section in Figure 2, Figure 3, and Figure 4.

Note 2) Ambient temperatures of the transmitter itself

Note 3) Approximate values at the temperature of 25°C

Note 4) Note that if the operating temperature falls below the lower limit of the normal operating range, the response of the transmitter becomes slower.

Temperature ranges of wetted parts:

See Table 2.

Ambient temperature ranges:

See Table 2, except for explosion-proof models with digital indicators, which have to be used within the following ranges:

Models with digital indicators:

Normal operating conditions: -20 to 70°C

Operative limits: -30 to 80°C

JIS pressure-resistant special explosion-proof models: -20 to 60°C

JIS intrinsically safe explosion-proof models: -10 to 60°C

Ambient humidity range:

5 to 100% RH

Stability against supply voltage change:

±0.005% FS/V

Lightning protection:

Peak value of voltage surge: 100 kV

Peak value of current surge: 1000 A

Dead time: Approx. 0.4 sec

Damping time constant:

Selectable from 0 to 32 sec in ten stages

Waterproof/dustproof structure:

JIS C0920 watertight: NEMA3 and 4X

JIS F8001 class 2 watertight: IEC IP67

Explosion-proof structure:

JIS special explosion-proof models: (Exds II CT4)

JIS intrinsically safe models: (i3aG4)

Table 2 Temperature Range of Wetted Parts Section and Ambient Temperature Range

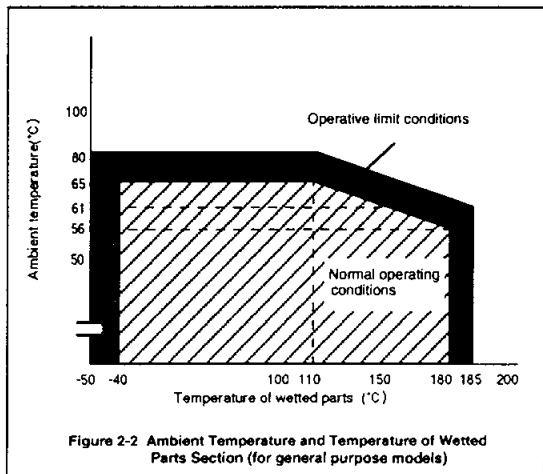
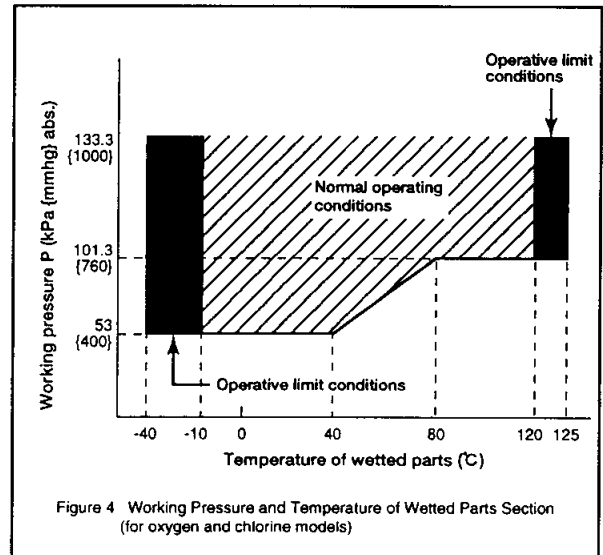
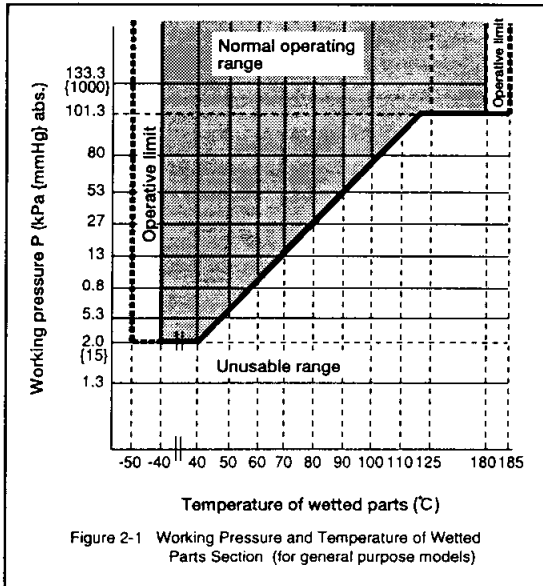
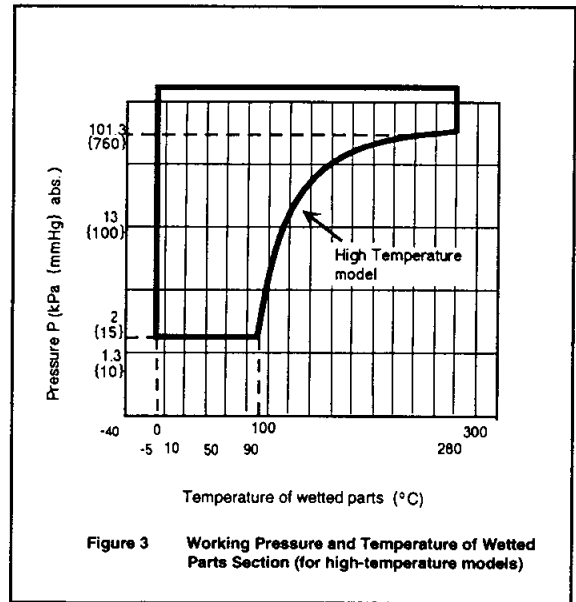
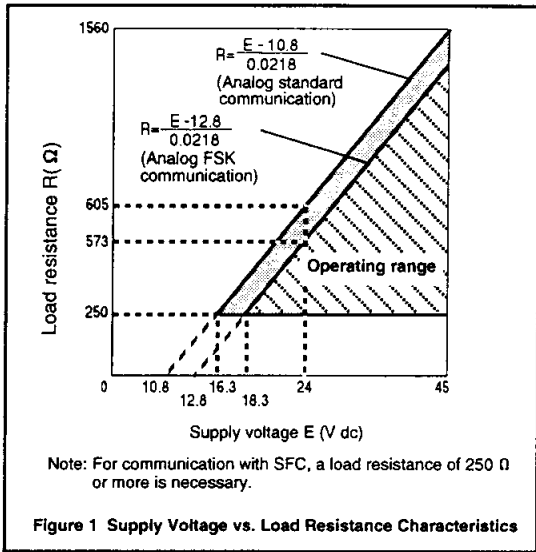

Note) If sealing liquid is for general purposes, please confirm the conditions listed in Figures 2-1 and 2-2.

Max Working Pressure

<ForNemloc>

Note1. Max Working Pressure depends on flange rating, flange materials and operating temperature. Please refer to the following data.
Operating range of temperature depends on specification of transmitters

Note2. In case of flange type (JTF940□, JTC940□) and remote sealed type (JTU940□, JTH940□),
Max Working Pressure depends on the smaller value of either 1.5MPa or following data.

Note3. In case of absolute remote sealed type (JTS940□),
Max Working Pressure depends on the smaller value of either 3.5MPa abs or following data.
As for the following data, the vertical axis represent gage pressure.
Please exchange of units from gage pressure to absolute pressure, when you use.

Note4. In case of remote sealed type (JTH980□), Max Working Pressure depends on the smaller value of either 10MPa or following data.

Note5. In case of 1/2B remote sealed type (JTE929□, JTE930□, JTH980□),
Max Working Pressure depends on the smaller value of either 5.1MPa or the following data as for adaptor flange (HF).

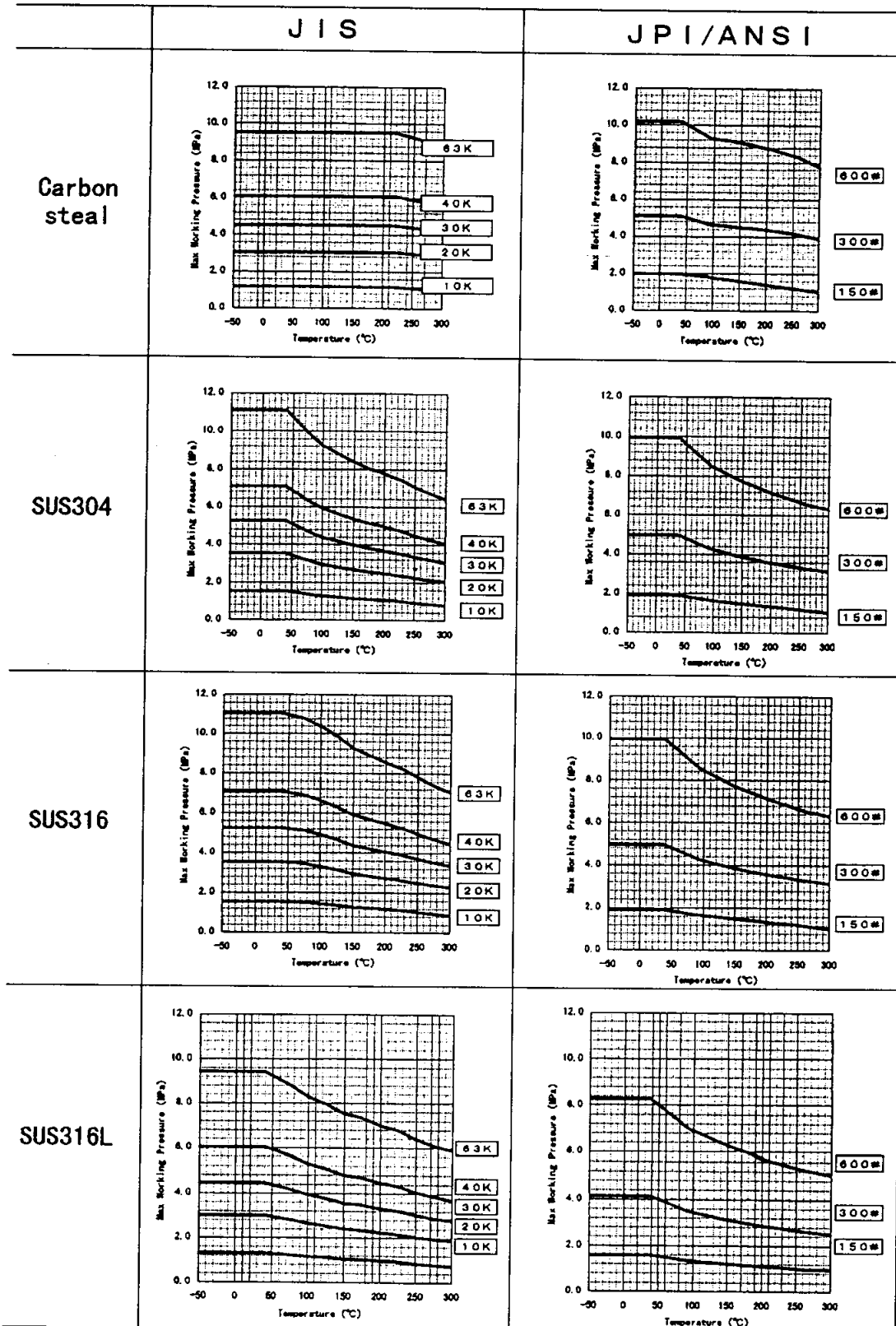

Process pipe connection:

- Flange adapters:
 - JIS10K, 20K, 30K-15A/20A (RF) equivalents
 - ANSI150, 300-1/2B, 3/4B (RF) equivalents
 - JPI150, 300-1/2B, 3/4B (RF) equivalents
- Screw connection:
 - Rc 1/2

Electrical conduit connection:

- G1/2 internal thread
- 1/2NPT internal thread (Not usable with JIS explosion-proof models)

Materials:

- Center body: SUS316
- Transmitter case: Aluminum alloy
- Meter body cover: SUSF304

Wetted parts materials:

- SUS316 (SUS316L for diaphragm only)
- SUS316L
- Hastelloy C (Consult us separately.)

Flange materials:

None

Bolts and nuts materials (for fastening meter body cover):

Carbon steel (SNB7), SUS630

Capillary section:

- Capillary tube length: 1, 2, 3, 4 and 5 m
- Capillary tube material: SUS316
- Armored tube material: SUS304
- Coating (optional): Olefin coating to improve corrosion resistance

Finish:

- Housing: light beige (Munsell 4Y7.2/1.3)
- Cap: dark beige (Munsell 10YR4.7/0.5)

Corrosion-resistant finish:

- Standard: Corrosion-resistant paint (Baked acrylic paint)
- Corrosion-resistant finish:
 - Corrosion-resistant paint (Baked acrylic paint), fungus-proof finish
- Corrosion-proof finish:
 - Corrosion-proof paint (Baked epoxy paint), fungus-proof finish
- Corrosion-resistant finish (silver paint):
 - Transmitter case is silver-painted in addition to the above corrosion-resistant finish.

Built-in indicating meter:

The digital LCD indicator (optional) indicates actual flow rates (in SI units) and can be set freely between -19999 and 19999 (4.5 digits). For actual calibration, specify the following items when placing your order:

- Actual calibration range
- Actual calibration unit
- Proportional representation and instructions about square-root extraction

Various kinds of data can be set using the SFC smart communicator (Ver. 7.1 or later).

Burnout feature:

- Choice of three states at abnormal condition:
 - Burnout of output values: none
 - upper limit
 - lower limit

Grounding:

Class 3 grounding (grounding resistance 100 Ω max.)

Mounting:

- Direct mounting on the process side
- Using 2-inch pipe mounting brackets:
 - Mount the transmitter on a horizontal or vertical 2-inch pipe, then use the brackets.
- Materials: Brackets: carbon steel
- U bolts and nuts: SUS304

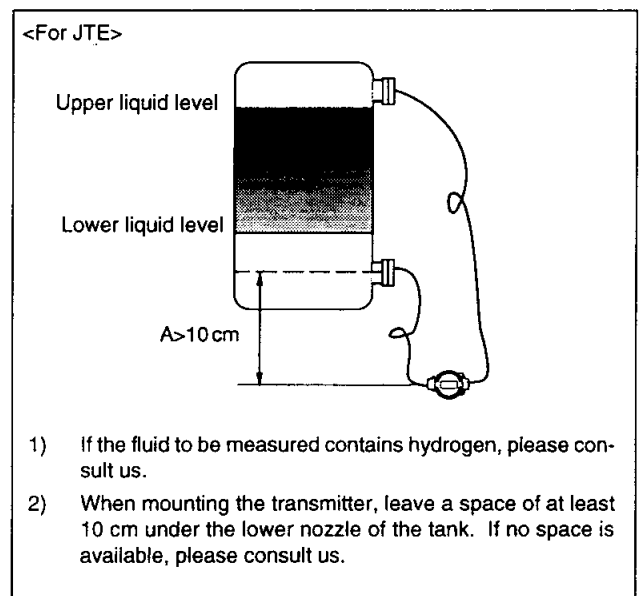
Mounting Notes**Weight:**

Approx. 6.9 kg
(including JTE929 capillary 1 m long)

Optional Specifications

External zero adjustment function:

The transmitter can be easily zero-adjusted in the field with a flat-blade screwdriver.

Additional lightning protection:

It is possible to achieve a lightning protection performance of 200 kV, 2000 A, twice the standard performance (100 kV, 1000 A). This is advisable when the transmitter is to be used in lightning-prone areas such as mountains, hills and wherever high-performance lightning protection is required.

1/2B remote mounting kit:

This is an adaptor with a vent drain for connecting the remote-sealed section (pressure diaphragm) to the process pipe.

For 1/2B, 3/4B flanges and screw connection Rc 1/2 are available for process pipes.

This adapter is packed without being mounted to the transmitter unless specified.

Materials of gaskets:

SUS316 (hoop)
PTFE (filler)

Elbow:

This is an adaptor for changing the electrical conduit connection port from the horizontal to the vertical direction, if required by wiring conditions in the field. One or two elbows may be used as needed.

Water inhibiting treatment (including oil inhibiting treatment):

The transmitter is shipped with dry and oil-free wetted parts.

Oil inhibiting treatment:

The transmitter is shipped with oil-free wetted parts. (The vent drain plug is coated with a small amount of fluorine oil to prevent galling.)

Electric power specification:

This specification applies where stringent quality control is required, such as in the electric power and city gas industries.

Special burnout (3.2 mA):

The burnout output value (in the lower-limit direction) under abnormal conditions shall be 3.2 mA (-5%) or less.

Test report:

The test report indicates the results of appearance, I/O characteristics, insulation resistance, and breakdown voltage tests.

Mill sheet:

The mill sheet shows the chemical composition, heat-treatment conditions, and mechanical properties of the materials used for the wetted parts.

Documents of conformance to the High Pressure Gas Control Law (for general purposes):

This specification applies when documents verifying conformance to the High Pressure Gas Control Law are required. The documents consist of a strength calculation sheet, the mill sheet, and a pressure resistance and gas-tightness test result sheet.

Strength calculation sheet:

The strength calculation sheet indicates the strength of the meter body cover, flanges, bolts, etc.

Pressure resistance and gas-tightness tests (for general purposes):

The pressure resistance and gas-tightness test result sheet shows the results of a pressure resistance test (under water pressure for 10 minutes) performed on the wetted parts.

Traceability certificate:

This certificate consists of three parts: the transmitter's measurement control system configuration diagram, a calibration certificate, and a test report.

Conformance to non-SI units:

We deliver transmitters set to any non-SI unit you specify.

Transmitter Handling Notes

To make the most of the performance this transmitter can offer, please use it properly noting the points mentioned below. Before using it, please read the instruction Manual.

Transmitter Installation Notes

Warning

- When installing the transmitter, ensure that gaskets do not protrude from connecting points into the process (such as adapter flange connection points and connecting pipes and flanges). Gasket protrusion may cause leaks and output errors.
- Do not use the transmitter outside its defined pressure, temperature, and connection specifications. A serious accident may otherwise occur due to damage and leaks.
- When performing wiring work in explosion-proof areas, follow the work method specified in the explosion-proof guidelines. In addition, when the wiring for an explosion-proof product is a pull-in pressure-resistant packing-cable, be sure to use a pressure-resistant packing-cable adapter certified by Yamatake-Honeywell.
- When conduits are used for connection, be sure to use conduit fittings certified by Yamatake-Honeywell.

Caution

- After installing the transmitter, do not step on it. Using it as a foothold or the like could make it collapse and cause injury.
- Be careful not to hit the glass indicator with tools etc. This could break the glass and cause injury.
- This transmitter is heavy. Wear safety shoes and take care when installing it.

Wiring Notes

Warning

- To avoid shocks, do not perform electrical wiring work with wet hands or with live wires.

Caution

- Do wiring work properly in conformance with the specifications. Wiring mistakes may result in breakdown.
- Use a power supply that conforms to the specifications. Use of an improper power supply may result in breakdown.

Performance

Shown for each item are the upper limit (URV) ⁽¹⁾ and the lower limit (LRV) ⁽²⁾ of the calibration range or the percentage ratio of the maximum value of the span to χ (kPa).

JTE929A (for general purpose models) Material for Wetted Parts: SUS316/SUS316L

Accuracy	Linear output:	$\pm 0.3\%$ ($\chi \geq 12.5\text{kPa}$ {1250mmH ₂ O})
		$\pm (0.3 \times \frac{12.5}{\chi})\%$ ($\chi < 12.5\text{kPa}$ {1250mmH ₂ O})
	Square-root output:	When output is 50 to 100%: same as linear output When output is 7.1 to 50%: linear output $\times \frac{50}{\text{square-root output } \%}$ When output is less than 7.1%: dropout
Temperature characteristics (Shift from the set range)	Zero shift:	$\pm 0.75\%$ ($\chi \geq 25\text{kPa}$ {2500mmH ₂ O})
		$\pm 0.75 \times \frac{25}{\chi}\%$ ($\chi < 25\text{kPa}$ {2500mmH ₂ O})
Change of 55°C ⁽⁴⁾	Combined shift: (including zero and span shifts)	$\pm 1.6\%$ ($\chi \geq 25\text{kPa}$ {2500mmH ₂ O}) $\pm 1.6 \times \frac{25}{\chi}\%$ ($\chi < 25\text{kPa}$ {2500mmH ₂ O})
Static pressure effect (Shift with respect to setting range) ⁽⁴⁾	Zero shift:	$\pm 1.47\%$ ($\chi \geq 25\text{kPa}$ {2500mmH ₂ O})
		$\pm (1.47 \times \frac{25}{\chi})\%$ ($\chi < 25\text{kPa}$ {2500mmH ₂ O})
Change of 7MPa {70kgf/cm²}	Combined shift: (including zero and span shifts)	$\pm 1.97\%$ ($\chi \geq 25\text{kPa}$ {2500mmH ₂ O}) $\pm (1.97 \times \frac{25}{\chi})\%$ ($\chi < 25\text{kPa}$ {2500mmH ₂ O})

JTE929A (for high-temperature models) Material for Wetted Parts: SUS316/SUS316L

Accuracy	Linear output:	$\pm 0.3\%$ ($\chi \geq 12.5\text{kPa}$ {1250mmH ₂ O})
		$\pm (0.3 \times \frac{12.5}{\chi})\%$ ($\chi < 12.5\text{kPa}$ {1250mmH ₂ O})
	Square-root output:	When output is 50 to 100%: same as linear output When output is 7.1 to 50%: linear output $\times \frac{50}{\text{square-root output } \%}$ When output is less than 7.1%: dropout
Temperature characteristics (Shift from the set range) ⁽⁴⁾	Zero shift:	$\pm 0.36\%$ ($\chi \geq 25\text{kPa}$ {2500mmH ₂ O})
		$\pm 0.36 \times \frac{25}{\chi}\%$ ($\chi < 25\text{kPa}$ {2500mmH ₂ O})
Change of 10°C	Combined shift: (including zero and span shifts)	$\pm 2.18\%$ ($\chi \geq 25\text{kPa}$ {2500mmH ₂ O}) $\pm 2.18 \times \frac{25}{\chi}\%$ ($\chi < 25\text{kPa}$ {2500mmH ₂ O})
Static pressure effect (Shift with respect to setting range) ⁽⁴⁾	Zero shift:	$\pm 2.7\%$ ($\chi \geq 25\text{kPa}$ {2500mmH ₂ O})
		$\pm (2.7 \times \frac{25}{\chi})\%$ ($\chi < 25\text{kPa}$ {2500mmH ₂ O})
Change of 7MPa {70kgf/cm²}	Combined shift: (including zero and span shifts)	$\pm 3.5\%$ ($\chi \geq 25\text{kPa}$ {2500mmH ₂ O}) $\pm (3.5 \times \frac{25}{\chi})\%$ ($\chi < 25\text{kPa}$ {2500mmH ₂ O})

JTE930A (for general purpose and high-temperature models) Material for Wetted Parts: SUS316/SUS316L

Accuracy ⁽³⁾	Linear output:	$\pm 0.2\%$ ($\chi \geq 210\text{kPa}$ {2.1kgf/cm ² })
		$\pm (0.05 + 0.15 \times \frac{210}{\chi})\%$ ($\chi < 210\text{kPa}$ {2.1kgf/cm ² })
	Square-root output:	When output is 50 to 100%: same as linear output When output is 7.1 to 50%: linear output $\times \frac{50}{\text{square-root output } \%}$ When output is less than 7.1%: dropout
Temperature characteristics (Shift from the set range) ^(3, 4)	Zero shift:	$\pm (0.25 + 0.15 \times \frac{210}{\chi})\%$
	Combined shift: (including zero and span shifts)	$\pm 2.8\%$ ($\chi \geq 210\text{kPa}$ {2.1kgf/cm ² }) $\pm (2.2 + 0.6 \times \frac{210}{\chi})\%$ ($\chi < 210\text{kPa}$ {2.1kgf/cm ² })
Static pressure effect (Shift with respect to setting range) ^(3, 4)	Zero shift:	$\pm \left\{ \left(\frac{T-25}{200} + 0.47 \right) \times \frac{700}{\chi} + 0.03 \right\} \%$
	Combined shift:	$\pm \left\{ \left(\frac{T-25}{200} + 0.72 \right) \times \frac{1400}{\chi} + 0.03 \right\} \%$
Change of 7MPa {70kgf/cm²}		T: ambient temperature (°C)

Notes) ⁽¹⁾: URV denotes the value for 100% (20 mA dc) output.

⁽²⁾: LRV denotes value for 0% (4 mA dc) output.

⁽³⁾: Within a range of URV ≥ 0 and LRV ≥ 0

⁽⁴⁾: Condition: the capillary length is up to 3 m. If exceeding 3 m, please consult us separately.

JTE929A (for general purpose and high-temperature models)

Material for Wetted Parts: Hastelloy C ^(*)

<p>Accuracy</p>	<p>Linear output: $\pm 0.4\%$ ($\chi \geq 12.5\text{kPa}$ {1250mmH₂O}) $\pm (0.4 \times \frac{12.5}{\chi})\%$ ($\chi < 12.5\text{kPa}$ {1250mmH₂O})</p> <p>Square-root output: When output is 50 to 100%: same as linear output When output is 7.1 to 50%: linear output $\times \frac{50}{\text{square-root output } \%}$ When output is less than 7.1%: dropout</p>
<p>Temperature characteristics (Shift from the set range) Change of 30°C (Range from -5 to 55°C)</p>	<p>Zero shift: $\pm 2.15\%$ ($\chi \geq 25\text{kPa}$ {2500mmH₂O}) $\pm 2.15 \times \frac{25}{\chi} \%$ ($\chi < 25\text{kPa}$ {2500mmH₂O})</p> <p>Combined shift: (including zero and span shifts) $\pm 6.55\%$ ($\chi \geq 25\text{kPa}$ {2500mmH₂O}) $\pm 6.55 \times \frac{25}{\chi} \%$ ($\chi < 25\text{kPa}$ {2500mmH₂O})</p>
<p>Static pressure effect (Shift with respect to setting range) Change of 7MPa {70kgf/cm²}</p>	<p>Zero shift: $\pm 6.00\%$ ($\chi \geq 25\text{kPa}$ {2500mmH₂O}) $\pm (6.00 \times \frac{25}{\chi}) \%$ ($\chi < 25\text{kPa}$ {2500mmH₂O})</p> <p>Combined shift: (including zero and span shifts) $\pm 7.00\%$ ($\chi \geq 25\text{kPa}$ {2500mmH₂O}) $\pm (7.00 \times \frac{25}{\chi}) \%$ ($\chi < 25\text{kPa}$ {2500mmH₂O})</p>

JTE930A (for general purpose and high-temperature models)

Material for Wetted Parts: Hastelloy C ^(*)

<p>Accuracy ^(*)</p>	<p>Linear output: $\pm 0.2\%$ ($\chi \geq 210\text{kPa}$ {2.1kgf/cm²}) $\pm (0.05 + 0.15 \times \frac{2.1}{\chi})\%$ ($\chi < 210\text{kPa}$ {2.1kgf/cm²})</p> <p>Square-root output: When output is 50 to 100%: same as linear output When output is 7.1 to 50%: linear output $\times \frac{50}{\text{square-root output } \%}$ When output is less than 7.1%: dropout</p>
<p>Temperature characteristics (Shift from the set range) Change of 30°C ^(*) (Range from -5 to 55°C)</p>	<p>Zero shift: $\pm (0.15 + 0.7 \times \frac{210}{\chi})\%$</p> <p>Combined shift: (including zero and span shifts) $\pm 3.0\%$ ($\chi \geq 210\text{kPa}$ {2.1kgf/cm²}) $\pm (2.2 + 0.8 \times \frac{210}{\chi})\%$ ($\chi < 210\text{kPa}$ {2.1kgf/cm²})</p>
<p>Static pressure effect (Shift with respect to setting range) ^(*) Change of 7MPa {70kgf/cm²}</p>	<p>Zero shift: $\pm \{ (\frac{T-25}{200} + 0.47) \times \frac{700}{\chi} + 0.03 \} \%$</p> <p>Combined shift: (including zero and span shifts) $\pm \{ (\frac{T-25}{200} + 0.72) \times \frac{1400}{\chi} + 0.03 \} \%$</p> <p style="text-align: right;">T: ambient temperature (°C)</p>

- Notes) ⁽¹⁾: URV denotes the value for 100% (20 mA dc) output.
⁽²⁾: LRV denotes value for 0% (4 mA dc) output.
⁽³⁾: Within a range of URV ≥ 0 and LRV ≥ 0
⁽⁴⁾: Please consult us separately.

JTH940A (for general purpose and high-temperature models)
Material for Wetted Parts: SUS316/SUS316L

Accuracy	Linear output:	$\pm 0.3\%$ $\pm (0.3 \times \frac{350}{\chi}) \%$	$(\chi \geq 350\text{kPa } \{3.5\text{kgf/cm}^2\})$ $(\chi < 350\text{kPa } \{3.5\text{kgf/cm}^2\})$
	Temperature characteristics (Shift from the set range) Change of 55°C	Zero shift: Combined shift:	$\pm (0.25 + 0.5 \times \frac{350}{\chi}) \%$ $\pm 1.05\%$ $\pm (0.35 + 0.7 \times \frac{350}{\chi}) \%$ $(\chi \geq 350\text{kPa } \{3.5\text{kgf/cm}^2\})$ $(\chi < 350\text{kPa } \{3.5\text{kgf/cm}^2\})$

JTH940A (for general purpose and high-temperature models)
Material for Wetted Parts: Hastelloy C ^(*)

Accuracy	Linear output:	$\pm 0.3\%$ $\pm (0.3 \times \frac{350}{\chi}) \%$	$(\chi \geq 350\text{kPa } \{3.5\text{kgf/cm}^2\})$ $(\chi < 350\text{kPa } \{3.5\text{kgf/cm}^2\})$
	Temperature characteristics (Shift from the set range) Change of 30°C (Range from -5 to 55°C)	Zero shift: Combined shift:	$\pm 0.68\%$ $(0.68 \times \frac{350}{\chi}) \%$ $(\chi \geq 350\text{kPa } \{3.5\text{kgf/cm}^2\})$ $(\chi < 350\text{kPa } \{3.5\text{kgf/cm}^2\})$ $\pm 1.75\%$ $\pm (1.75 \times \frac{350}{\chi}) \%$ $(\chi \geq 350\text{kPa } \{3.5\text{kgf/cm}^2\})$ $(\chi < 350\text{kPa } \{3.5\text{kgf/cm}^2\})$

JTH960A (for general purpose and high-temperature models)
Material for Wetted Parts: SUS316/SUS316L

Accuracy	Linear output:	$\pm 0.4\%$ $\pm (0.4 \times \frac{3.5}{\chi}) \%$	$(\chi \geq 3.5\text{MPa } \{35\text{kgf/cm}^2\})$ $(\chi < 3.5\text{MPa } \{35\text{kgf/cm}^2\})$
	Temperature characteristics (Shift from the set range) Change of 55°C	Zero shift: Combined shift:	$\pm (0.25 + 0.5 \times \frac{3.5}{\chi}) \%$ $\pm 1.5\%$ $\pm (0.35 + 0.7 \times \frac{3.5}{\chi}) \%$ $(\chi \geq 3.5\text{MPa } \{3.5\text{kgf/cm}^2\})$ $(\chi < 3.5\text{MPa } \{3.5\text{kgf/cm}^2\})$

JTH960A (for general purpose and high-temperature models)
Material for Wetted Parts: Hastelloy C ^(*)

Accuracy	Linear output:	$\pm 0.4\%$ $\pm (0.4 \times \frac{3.5}{\chi}) \%$	$(\chi \geq 3.5\text{MPa } \{3.5\text{kgf/cm}^2\})$ $(\chi < 3.5\text{MPa } \{3.5\text{kgf/cm}^2\})$
	Temperature characteristics (Shift from the set range) Change of 30°C (Range from -5 to 55°C)	Zero shift: Combined shift:	$\pm 0.68\%$ $(0.68 \times \frac{3.5}{\chi}) \%$ $(\chi \geq 3.5\text{MPa } \{3.5\text{kgf/cm}^2\})$ $(\chi < 3.5\text{MPa } \{3.5\text{kgf/cm}^2\})$ $\pm 1.75\%$ $\pm (1.75 \times \frac{3.5}{\chi}) \%$ $(\chi \geq 3.5\text{MPa } \{3.5\text{kgf/cm}^2\})$ $(\chi < 3.5\text{MPa } \{3.5\text{kgf/cm}^2\})$

 Notes) ^(*): Please consult us separately.

Model Number Configuration Table

ST3000 Ace Remote-Sealed Differential Pressure Transmitter (JTE) with 1/2B Remote Model for General Purpose and High-Temperature Models

Basic model number		Selections				Optional selections				Options Note 2)	
Measuring span	2.5~100kPa JTE929A 35~700kPa JTE930A									X X	No optional specifications
Forms of output/communication	4 to 20 mA dc (analog standard communication) 1 4 to 20mA dc (analog FSK communication) 2 DE output 3									A 2	External zero adjustment
Wetted parts material	SUS316 (diaphragm: SUS316L) 2 SUS316L 8 Hastelloy C Note 1) H									A 4	Additional lightning protection
Sealing liquid	For general purposes: silicone oil 1 For oxygen service: fluorine oil 2 For high-temperature model: silicone oil 3									A 6	1/2B remote mounting kit
Flange standard	No flange W									B 7	For special local field meter
Flange diameter	1/2B remote specification (removing the rear part of capillary) R									G 1	One elbow (left)
Flange shape	Standard 1									G 2	One elbow (right)
Flange material/Bolt/nut material	No flange/Carbon steel N No flange/SUS304 P No flange/SUS630 Q									G 3	Two elbows
Capillary length	1 m 1 2 m 2 3 m 3 4 m Note 1) 4 5 m Note 1) 5 1 m (Olefin covering) L 2 m (Olefin covering) B 3 m (Olefin covering) C 4 m (Olefin covering) Note 1) H 5 m (Olefin covering) Note 1) D									D 1	Water inhibiting treatment (including oil inhibition)
										D 2	Oil inhibition
										J 2	Power specifications
										J 8	Special burnout (3.2 mA)
										T 1	Test report
										T 2	Mill sheet
										T 3	Document conforming to High Pressure Gas Control Law (for general purposes)
										T 5	Strength calculation sheet
										T 6	Pressure resistance/gas-tightness test (for general purposes)
										T 8	Traceability certificate
										U 2	Non-SI unit conformance
										<input type="checkbox"/>	Other
						X	Electrical conduit and explosion-proof status			G1/2, not explosion-proof	
						1				G1/2, JIS explosion-proof, with single standard conduit fittings	
						H				G1/2, JIS explosion-proof, with double standard conduit fittings	
						2				G1/2, JIS explosion-proof, with single standard packing	
						3				G1/2, JIS explosion-proof, with double standard packing	
						6				G1/2, JIS intrinsically safe	
						A				1/2 NPT, not explosion-proof	
						<input type="checkbox"/>				Other	
						X	Indicator			No meter	
						1				Digital meter with standard reading (0 to 100%)	
						2				Digital meter with actual reading	
						X	Anticorrosion treatment			Standard coating	
						A				Anticorrosion treatment	
						B				Heavy-duty anticorrosion treatment	
						D				Silver anticorrosion treatment	
						X	Flange processing			None (Standard: JISRa3.2 (12.5 S))	
						X	Burnout feature			None	
						U				Upper limit of output at abnormal condition	
						D				Lower limit of output at abnormal condition	
						X	Mounting bracket			None	
						1				Carbon steel (mounted on 2B pipe)	
						<input type="checkbox"/>				Other	

Note 1) Please consult us separately.

Note 2) Please be sure to specify the 1/2B remote mounting kit (A6) as this is necessary for process pipe connecting.

ST3000 Ace Remote-Sealed Pressure Transmitter (JTH) with 1/2B Remote Model for General Purpose and High-Temperature Models

Basic model number		Selections				Optional selections				Options Note 2)		
Measuring span		70~3500kPa	J	T	H	9	4	0	A			
		1.4~10MPa	J	T	H	9	6	0	A			
Forms of output/communication	4 to 20 mA dc (analog standard communication)	1										
	4 to 20mA dc (analog FSK communication)	2										
	DE output	3										
Wetted parts material	SUS316 (diaphragm: SUS316L)	2										
	SUS316L	8										
	Hastelloy C Note 1)	H										
Sealing liquid	For general purposes: silicone oil	1										
	For oxygen service: fluorine oil	2										
	For high-temperature model: silicone oil	3										
Flange standard	No flange		W									
Flange diameter	1/2B remote specification (removing the rear part of capillary)			R								
Flange shape	Standard	1										
Flange material/ Bolt/nut material	No flange/Carbon steel		N									
	No flange/SUS304		P									
	No flange/SUS630		Q									
Capillary length	1 m	1										
	2 m	2										
	3 m	3										
	4 m Note 1)	4										
	5 m Note 1)	5										
	1 m (Olefin covering)	L										
	2 m (Olefin covering)	B										
	3 m (Olefin covering)	C										
	4 m (Olefin covering) Note 1)	H										
	5 m (Olefin covering) Note 1)	D										
Electrical conduit and explosion-proof status	X	G1/2, not explosion-proof										
	1	G1/2, JIS explosion-proof, with single standard conduit fittings										
	H	G1/2, JIS explosion-proof, with double standard conduit fittings										
	2	G1/2, JIS explosion-proof, with single standard packing										
	3	G1/2, JIS explosion-proof, with double standard packing										
	6	G1/2, JIS intrinsically safe										
	A	1/2 NPT, not explosion-proof										
	□	Other										
	X	Indicator	No meter									
	1		Digital meter with standard reading (0 to 100%)									
2		Digital meter with actual reading										
Anticorrosion treatment	X	Standard coating										
	A	Anticorrosion treatment										
	B	Heavy-duty anticorrosion treatment										
	D	Silver anticorrosion treatment										
X	Flange processing	None (Standard: JISR3.2 (12.5 S))										
X	Burnout feature	None										
U		Upper limit of output at abnormal condition										
D		Lower limit of output at abnormal condition										
X	Mounting bracket	None										
1		Carbon steel (mounted on 2B pipe)										
□		Other										

Note 1) Please consult with us.

Note 2) Please be sure to specify the 1/2B remote mounting kit (A6) as this is necessary for process pipe connecting.

1/2B Remote Mounting Kit (Accessory)

Model Number Example: HF-E1A23-X

		Basic model number	Selections			Options
Product category		1/2B remote mounting kit	H	F		
Models	For JTE (2 adaptor bodies)		E			X None
	For JTH (1 adaptor body)		H			1 Water inhibiting treatment (including oil inhibition)
Adapter	Flange diameter	1/2B flange		1		2 Oil inhibition
		3/4B flange		2		3 Long vent drain
		Screw-in Rc 1/2 (internal thread)		A		4 Mounting transmitter
	Flange standard/ rating	JIS10K		A		
		JIS20K		C		
		JIS30K		D		
		ANSI150		G		
		ANSI300		H		
		JPI150		N		
		JPI300		P		
No flange (Selectable in the case of "screw-in" for flange diameter)		X				
Adaptor body material	SUS316			2		
	Carbon steel with Zn			B		
Material of bolts/nuts to fasten adaptor body	Carbon steel				1	
	SUS630				3	

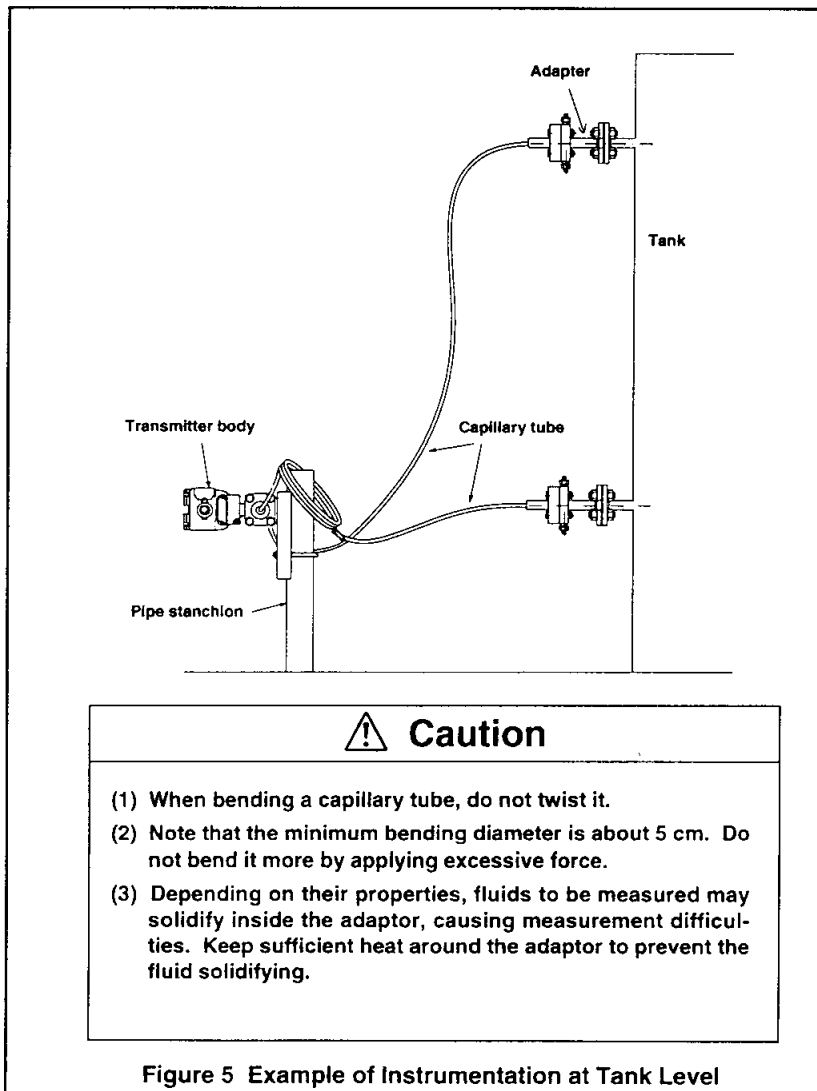

Dimensions

JTE929A/930A General Purpose and High-Temperature Models

(Unit: mm)

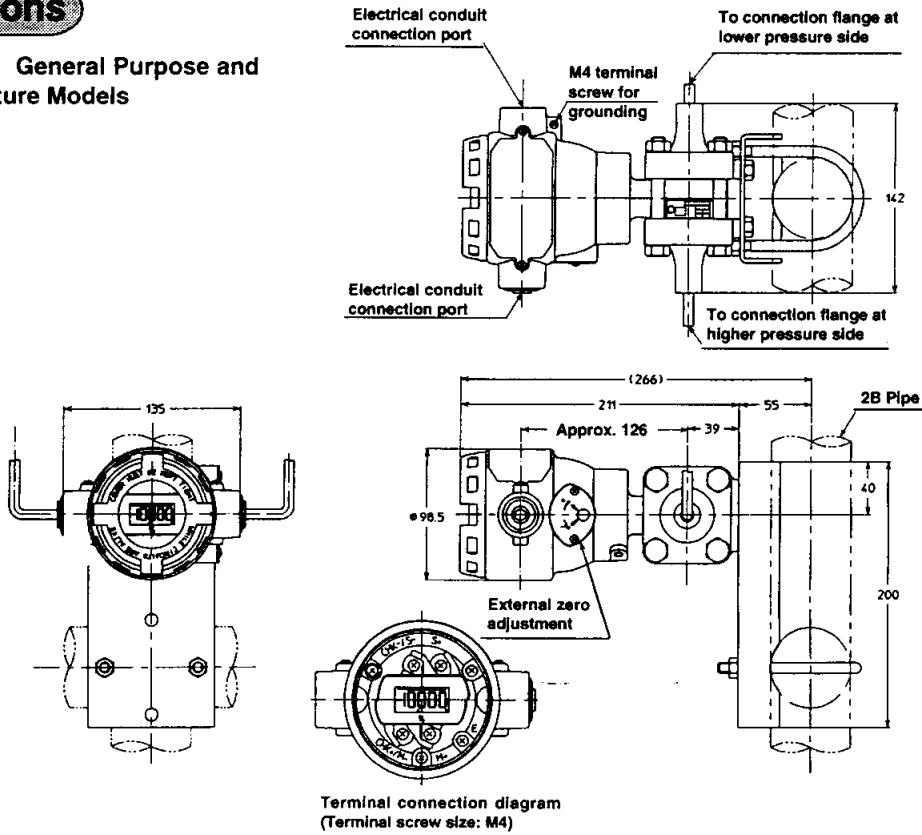

JTH940A/JTH960A General Purpose and High-Temperature Models

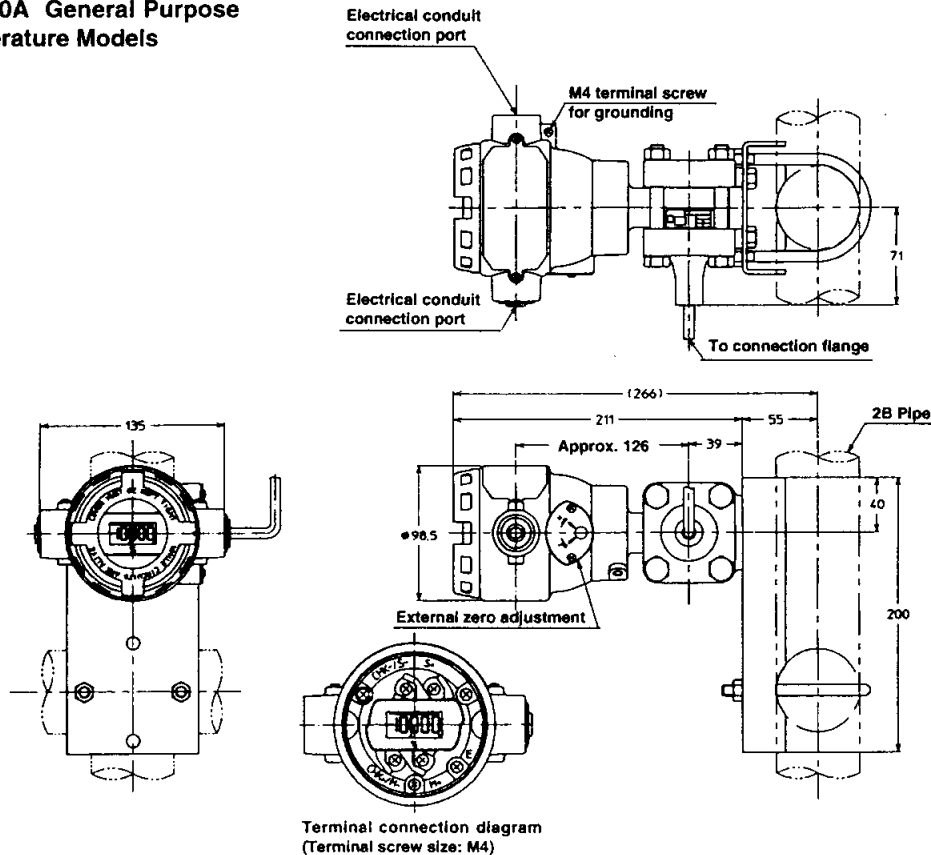

Notes)

1. The transmitter can be mounted in various ways by changing the position of the mounting bracket. (A typical example is shown in the figure.)
2. To prevent vibration, you are recommended to fasten the capillary tube mid-length.
3. Select a gasket that will not contact the diaphragm after it is tightened.
4. When the volume of suppression is larger than one half of the adjustment span, the higher pressure side and the lower pressure side of the process connection end flange are opposite to those shown in the figure. When using the transmitter to measure liquid levels, connect at H and L marks on the meter body as shown in the figure.

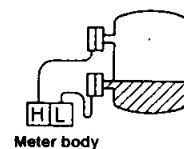

JTE929A/930A Table of Flush Diaphragm Flange Dimensions

1/2B or 3/4B Flange Adapter Assembly Drawing

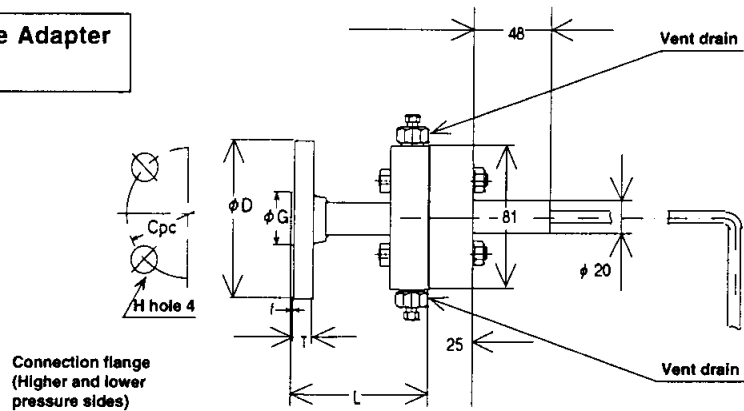

Screw-in Rc 1/2B Adapter Assembly Drawing

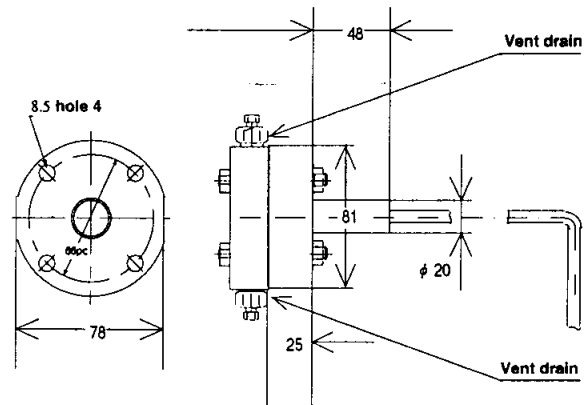

Flange standard	ϕD	ϕG	T	f	ϕC	ϕH	ϕL
JIS 10K-15A · 1/2	95	51	12	1	70	15	84
JIS 20K-15A · 1/2	95	51	14	1	70	15	84
JIS 30K-15A · 1/2	115	55	18	1	80	19	79
ANSI150-15A · 1/2	89	35.1	11.5	1.6	60.5	16	86
ANSI300-15A · 1/2	95	35.1	14.5	1.6	66.5	19	92
JPI150-15A · 1/2	89	35.1	11.5	1.6	60.5	16	86
JPI300-15A · 1/2	95	35.1	14.5	1.6	66.5	19	92
JIS 10K-20A · 3/4	100	56	14	1	75	15	90
JIS 20K-20A · 3/4	100	56	16	1	75	15	90
JIS 30K-20A · 3/4	120	60	18	1	85	19	84
ANSI150-20A · 3/4	99	42.9	13	1.6	69.8	16	90
ANSI300-20A · 3/4	117	42.9	16	1.6	82.6	19	99
JPI150-20A · 3/4	99	42.9	13	1.6	69.8	16	90
JPI300-20A · 3/4	117	42.9	16	1.6	82.6	19	99

MEMO

Document Number : CM2-DST300-2001
Document Name : ST3000 Ace Smart Transmitter
Electronic Differential Pressure Transmitter
Model JTR929A/930A ,JTE929A/JTE930A
(Remote Diaphragm Seal Type)

Date : Jan., 1997
July, 1998 (Rev. 1) (Y)

Issued / Edited by : Yamatake Corporation
