

Technical Training

AT9000 Advanced Transmitter

Model GTX



Yamatake Europe October 1st, 2008

azbil

Copyright © 2006 Yamatake Corporation All Rights Reserved.

- 1. GTX Hardware**
2. Identification & Model Selection
3. Wiring and installation
4. Configuration & CNF100
5. Hands-on-training

AT9000 Advanced Transmitter

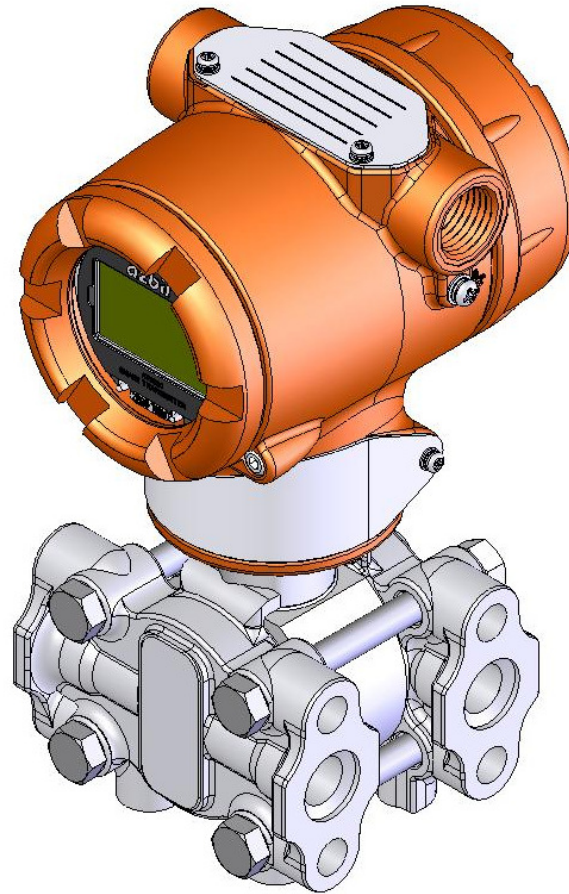

Model GTX

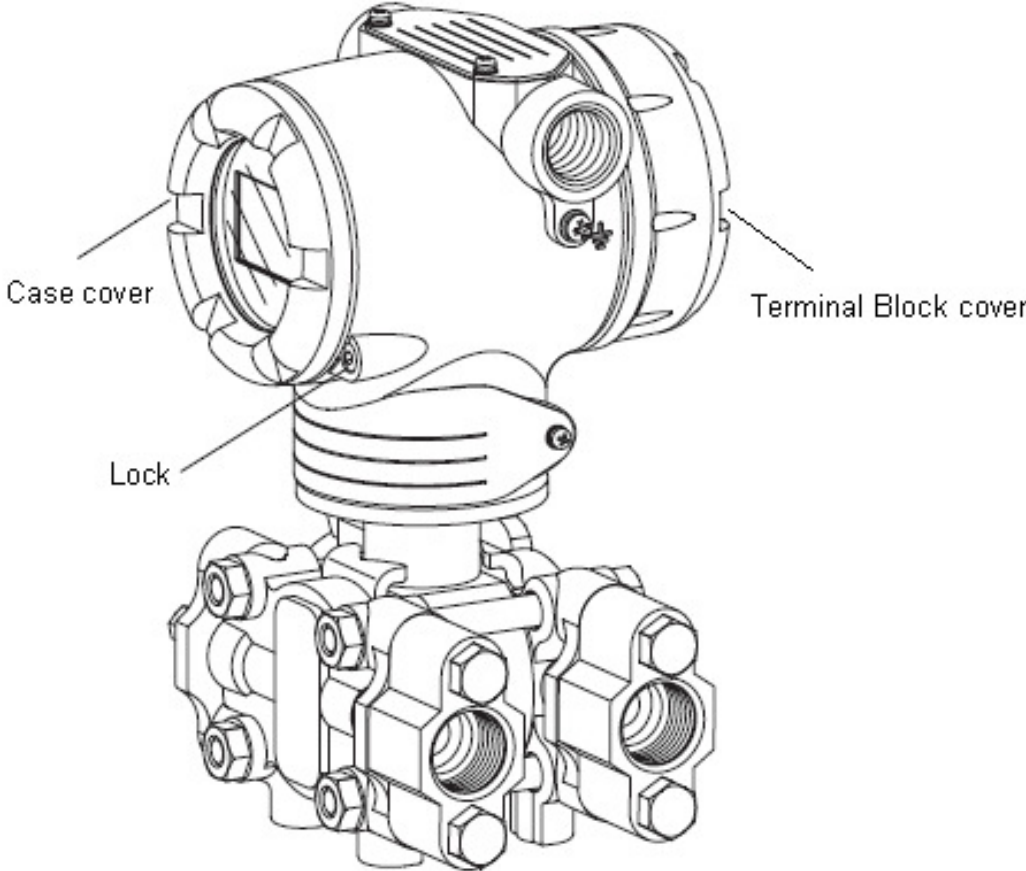

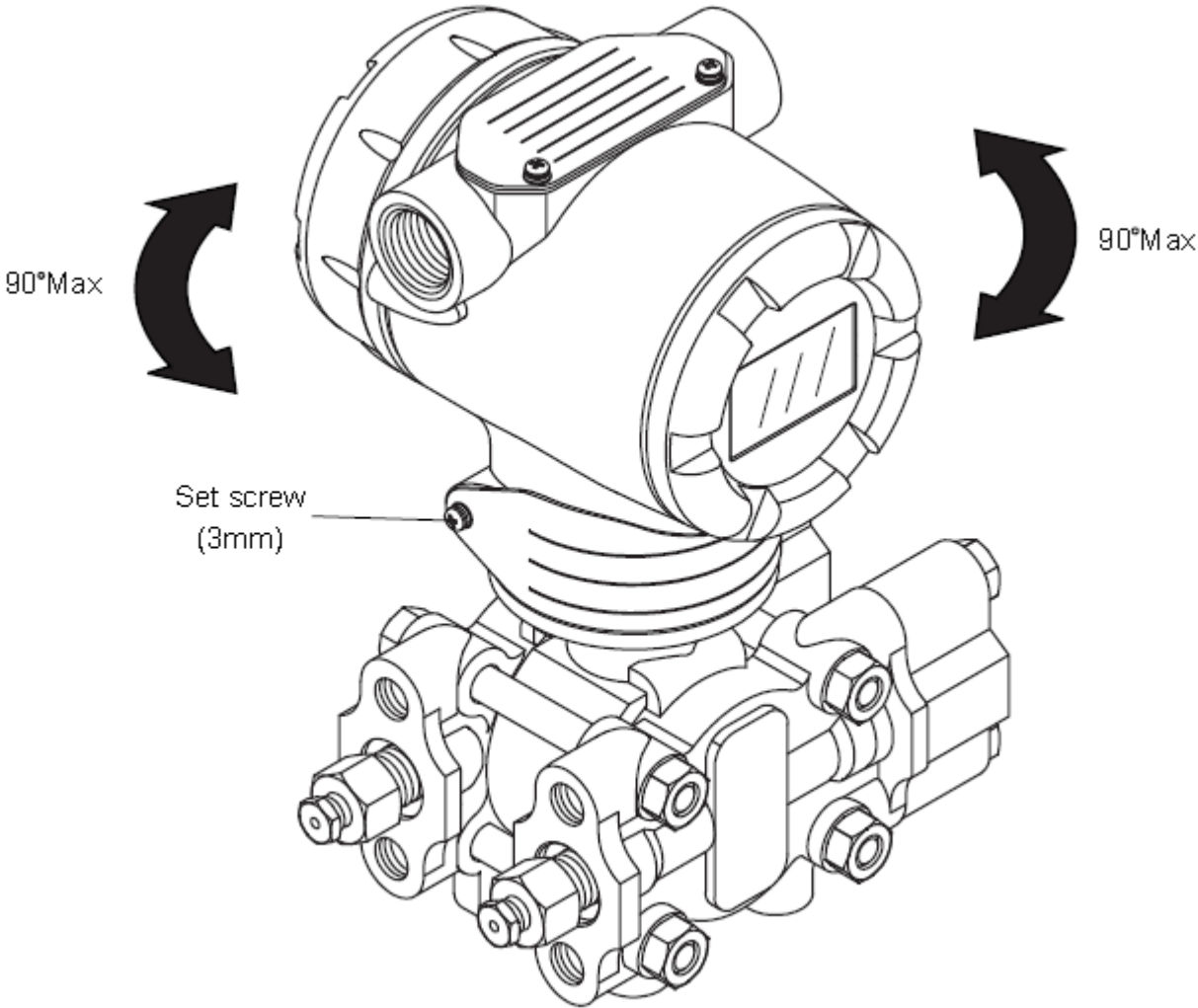

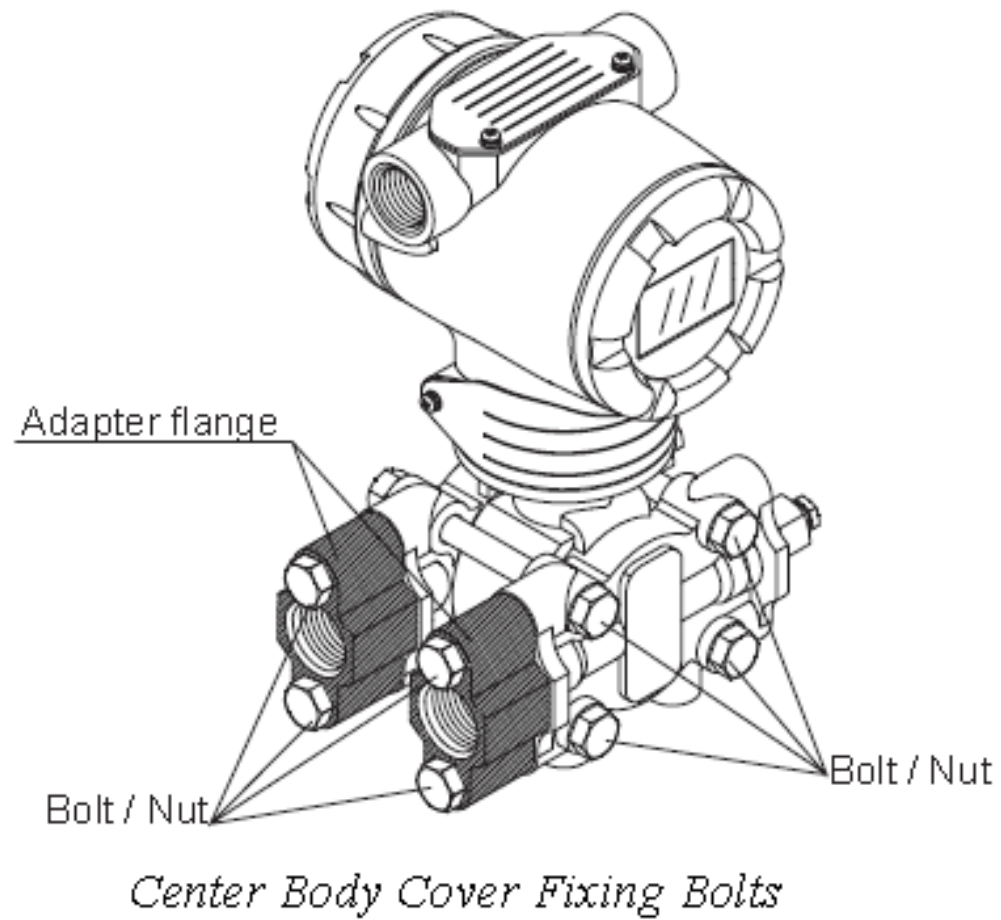

GTX Hardware

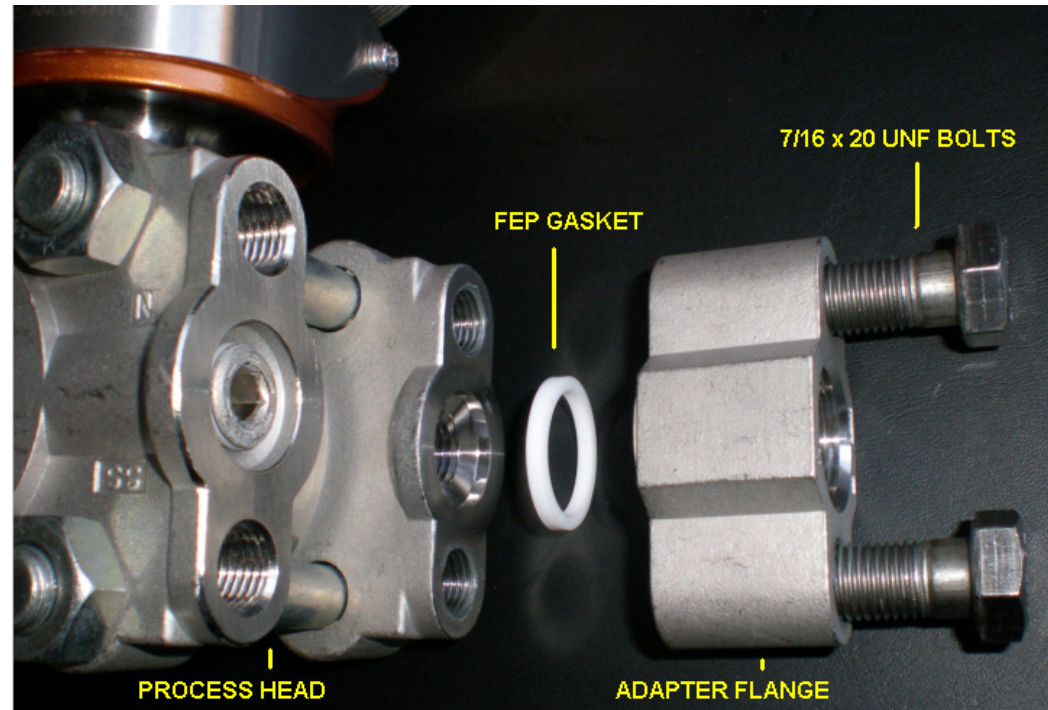
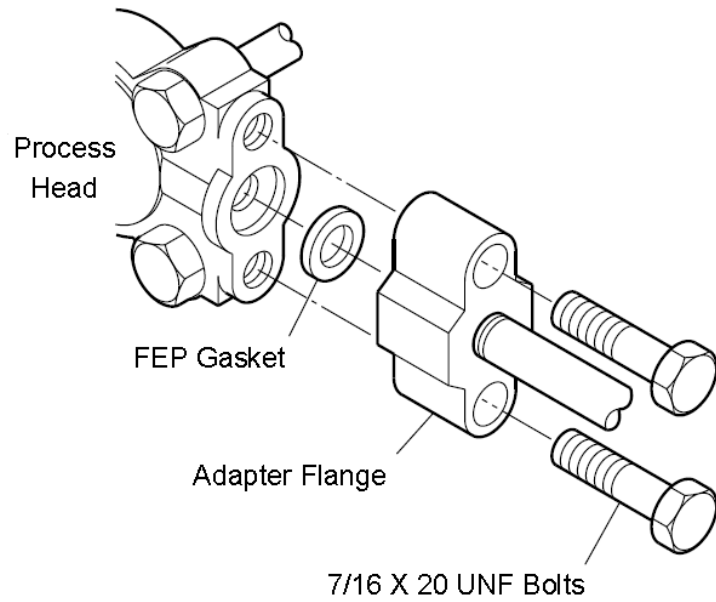

GTX Hardware



High-pressure side Low-pressure side

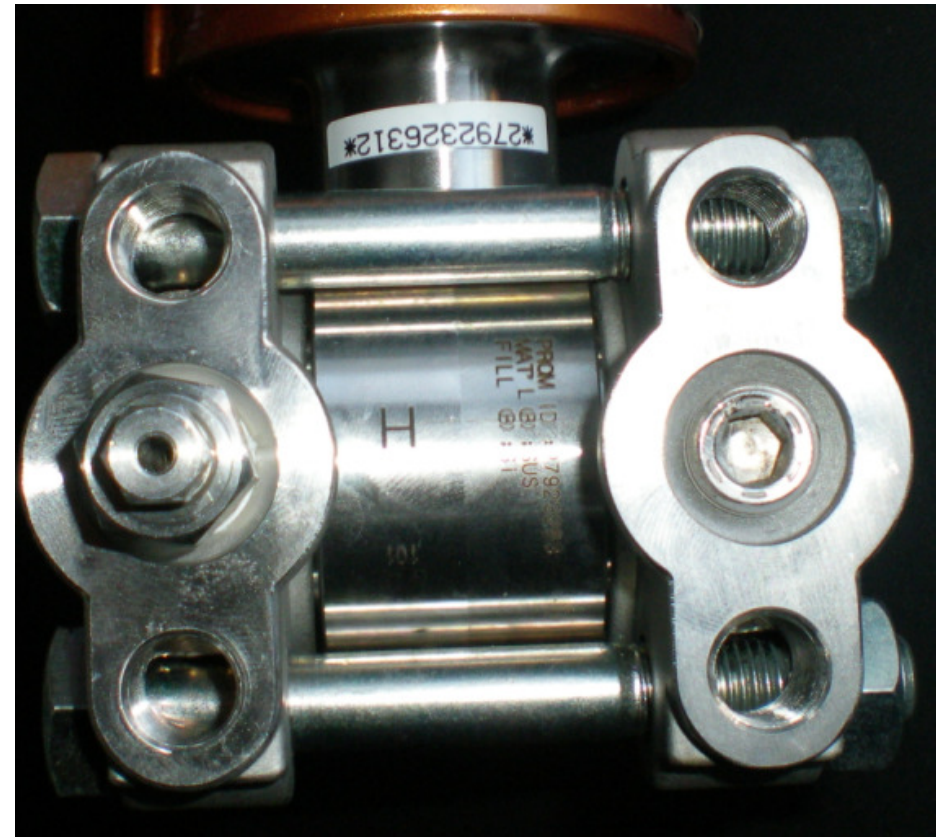
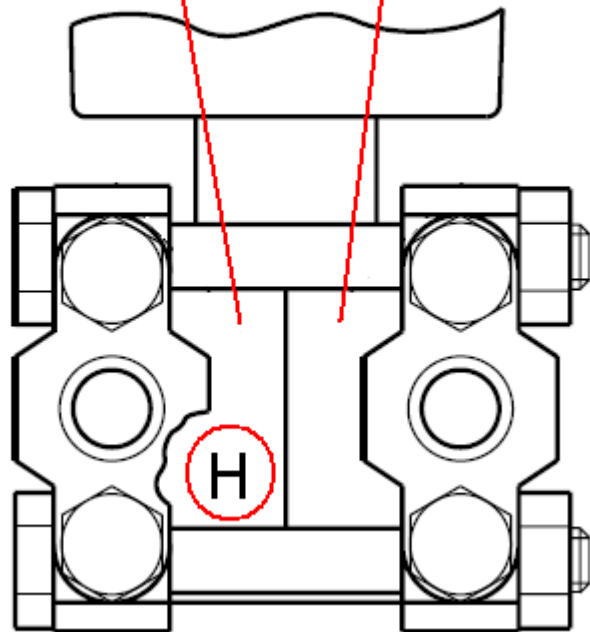

GTX Hardware

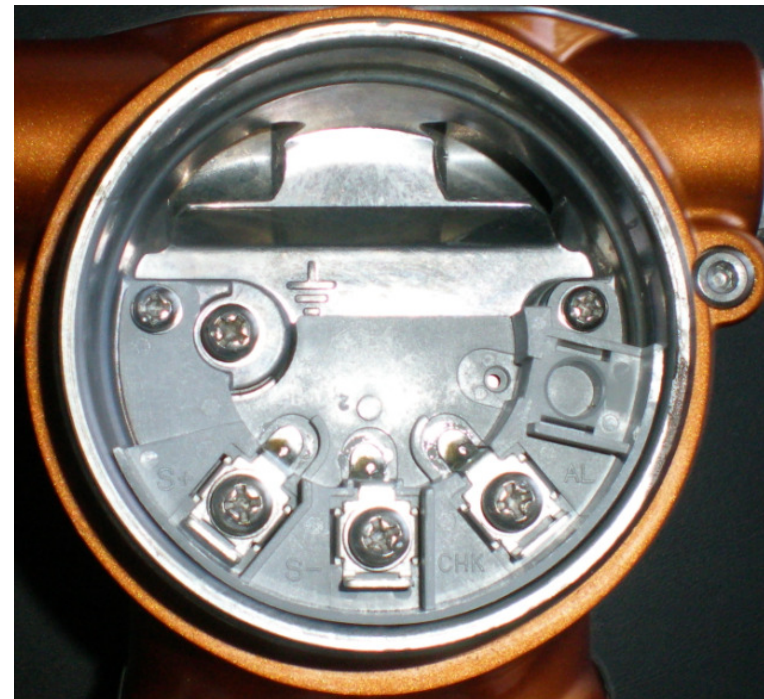
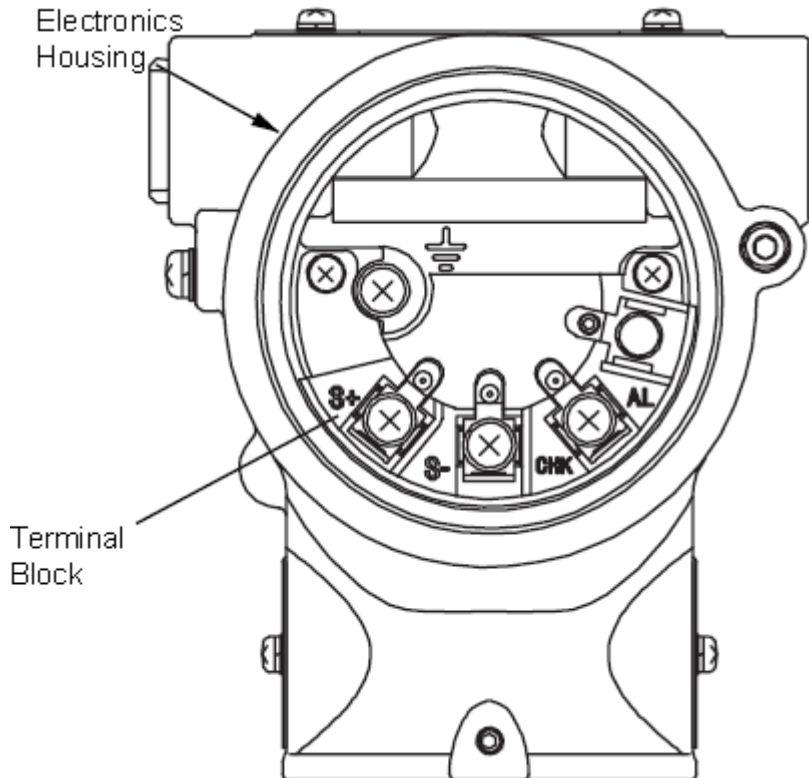

GTX Hardware

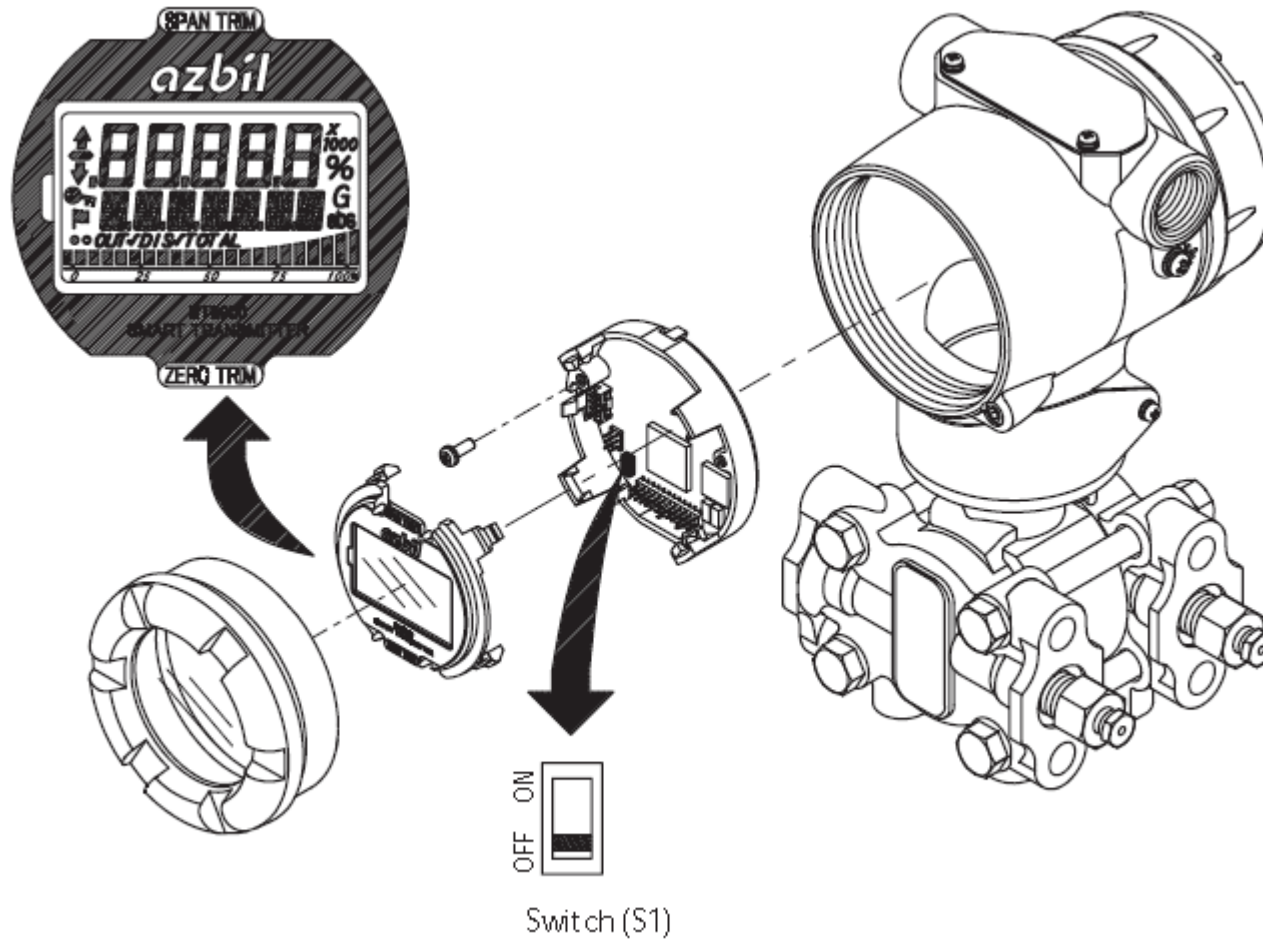

GTX Hardware

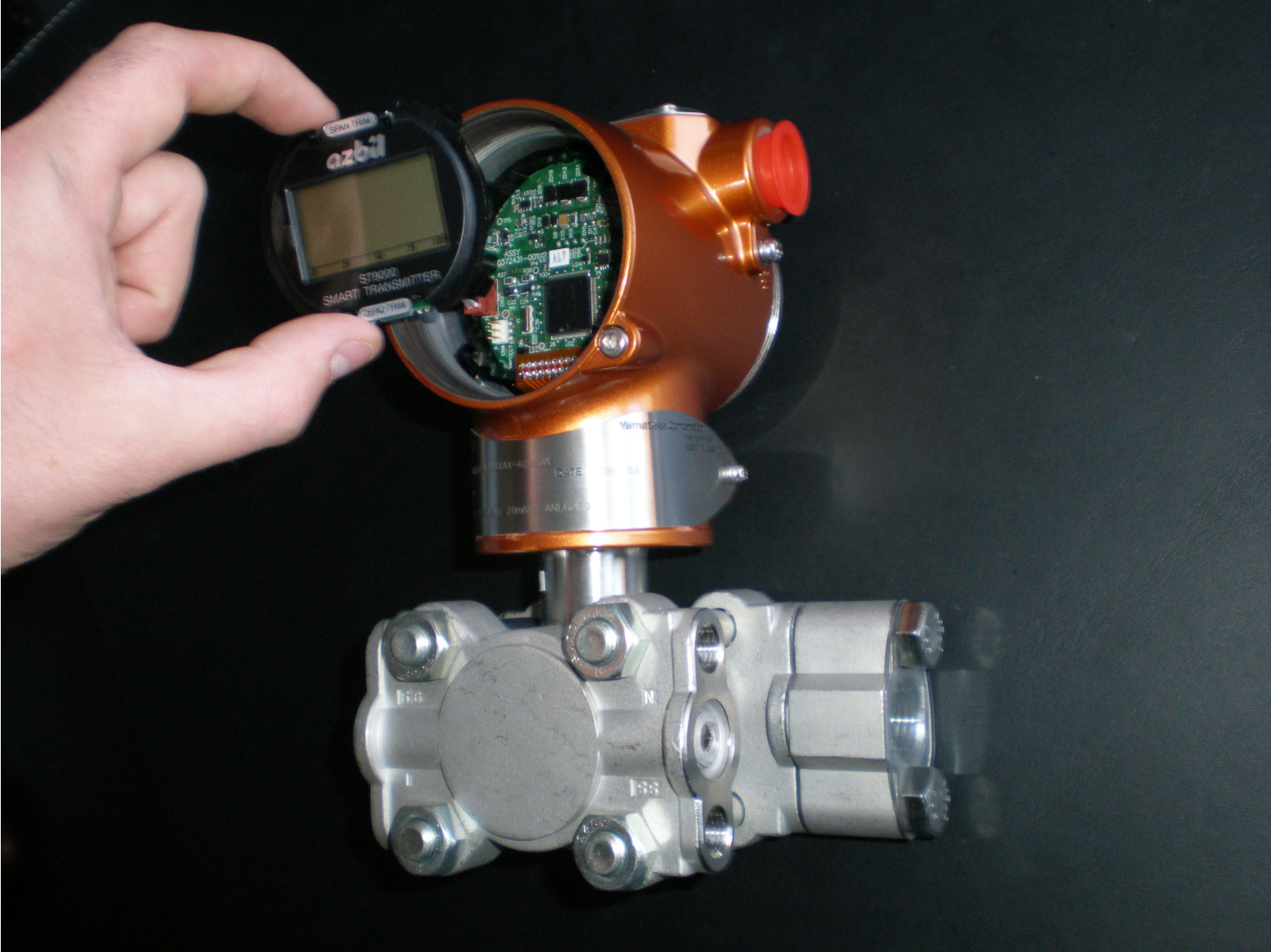

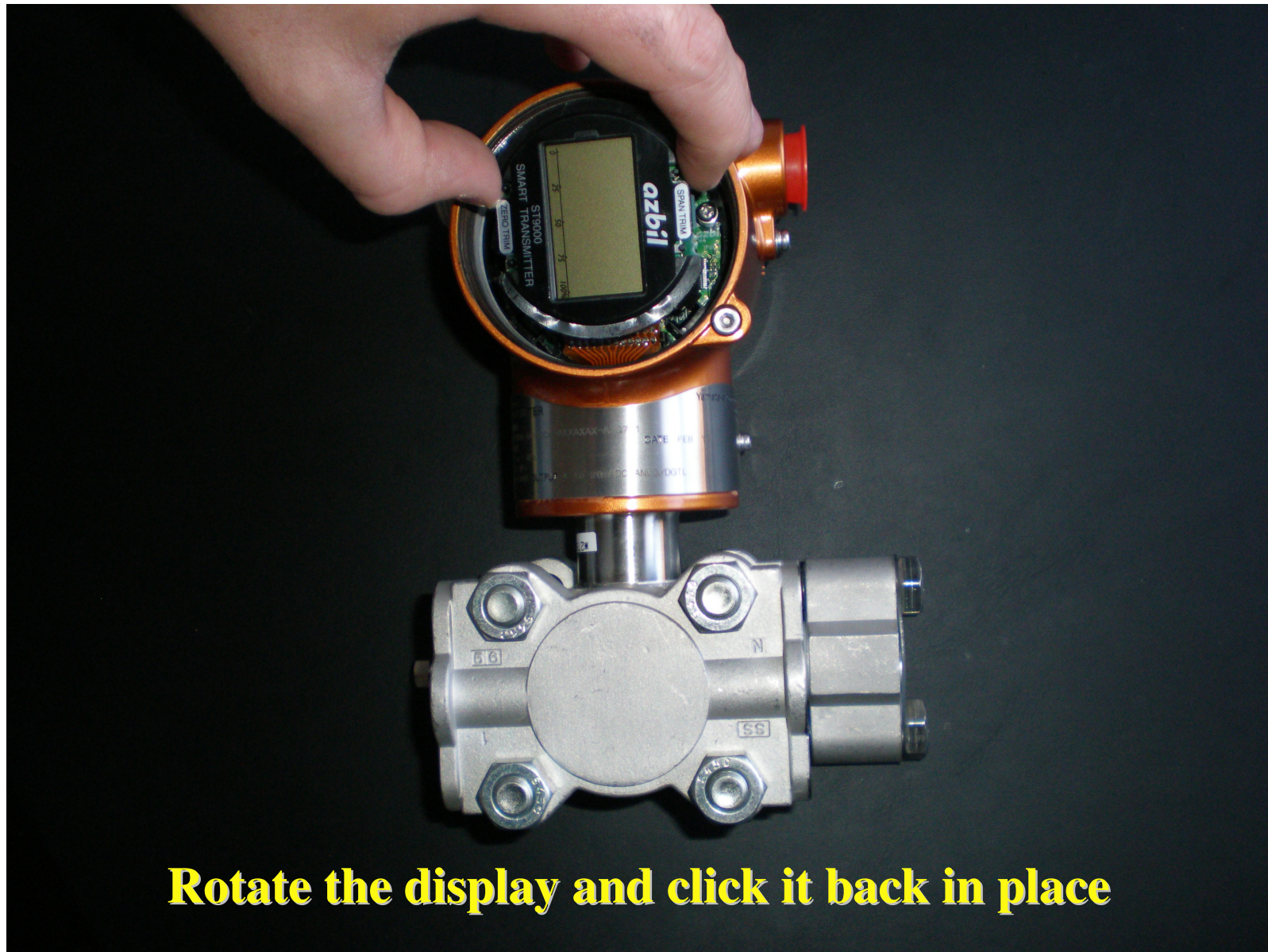

Rotate the display and click it back in place

GTX Hardware

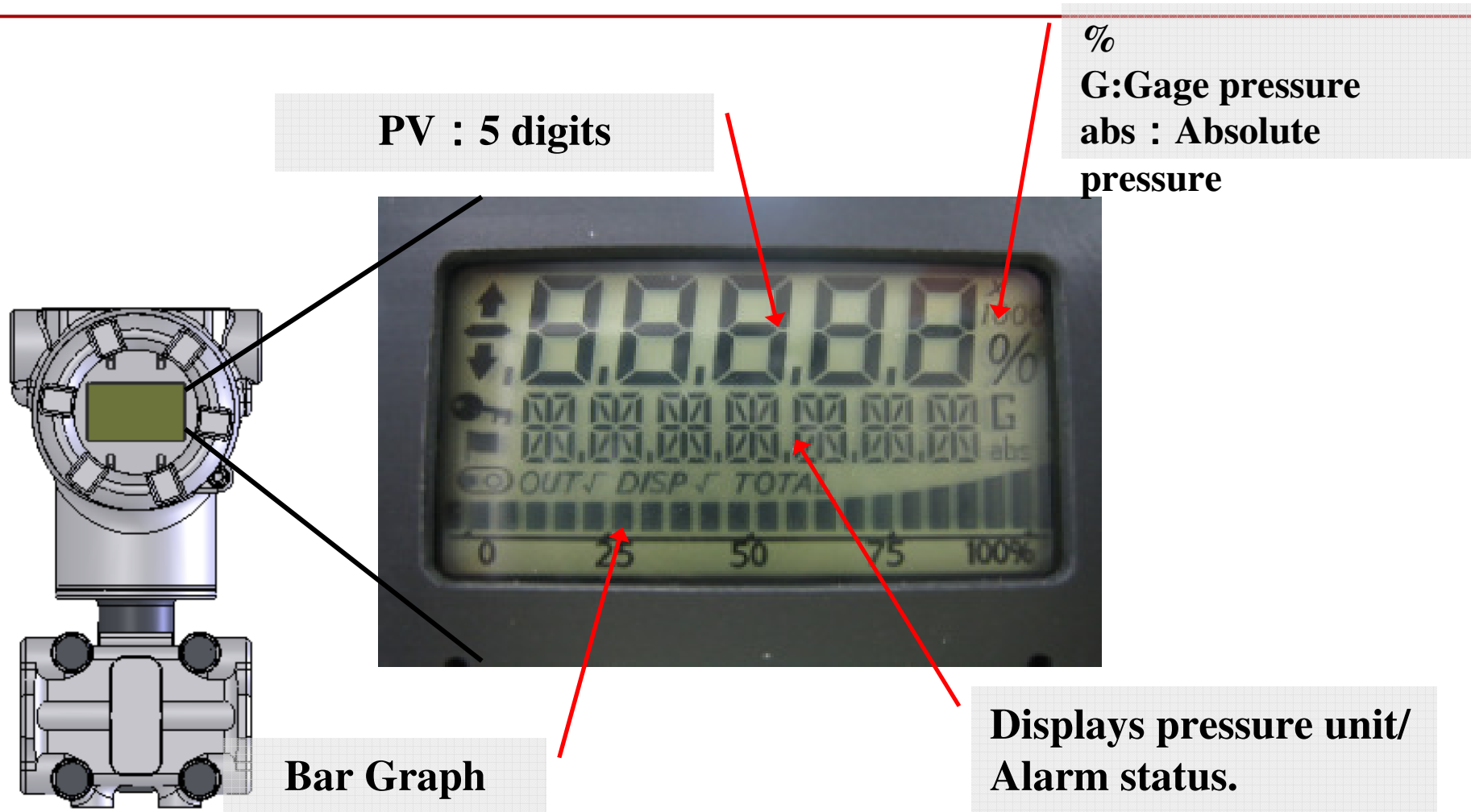

- Easily Viewable.
- Alarm status also can be confirmed

GTX Hardware

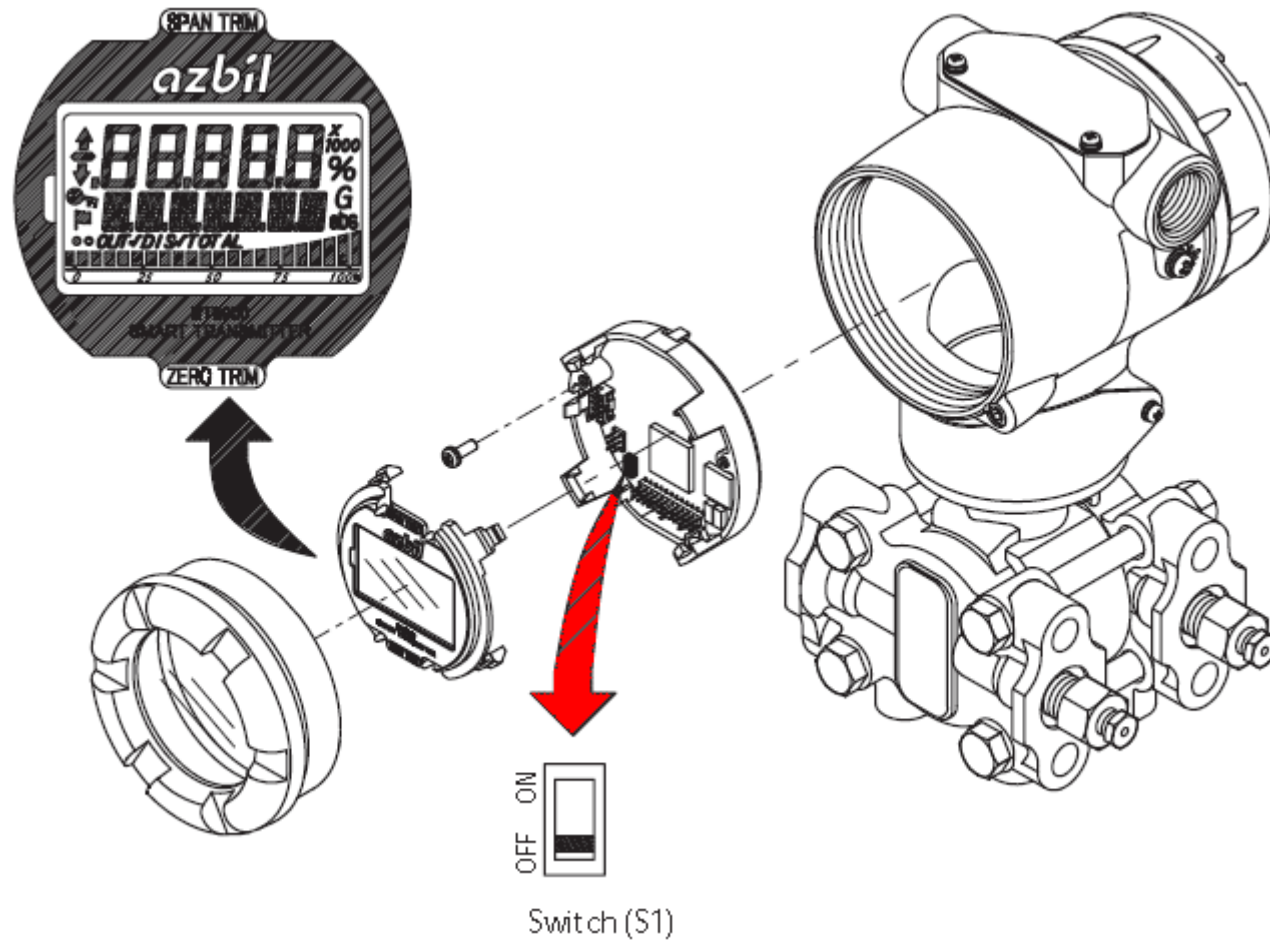

GTX Hardware

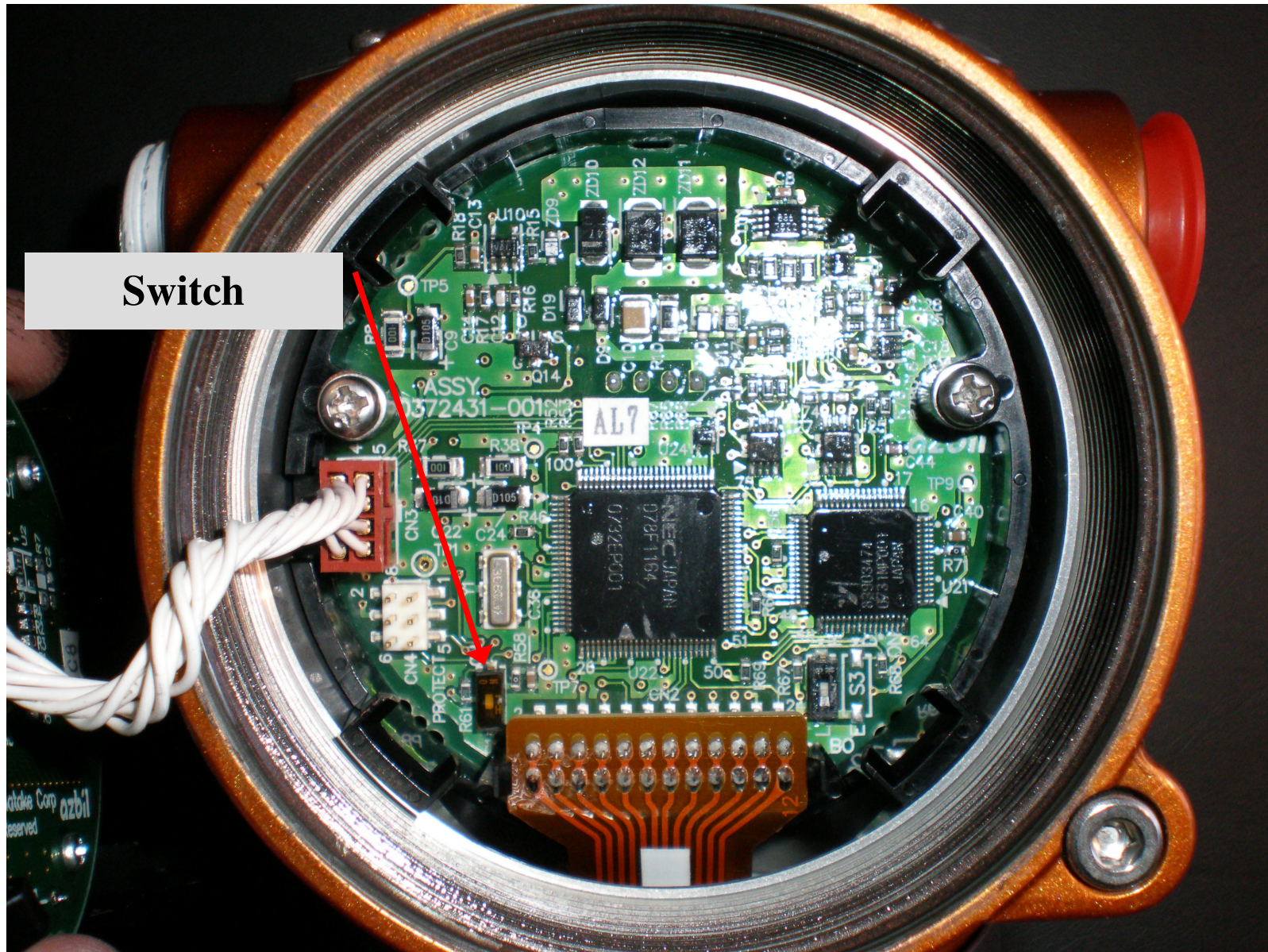

Write protect

1. Hardware write protect (switch)
2. Software write protect
 - This function prevents users from changing the settings of the transmitter using the communicator or external zero/span adjustment function.

1. Hardware write protect

- Switching the write protect ON and OFF can be executed with the slide switch (S1) on the electronics module.

2. Software write protect

- Switching the write protect ON and OFF can be executed with the communicator. When the hardware write protect is ON, switching with the communicator is not available.

- A transmitter with External Zero/Span adjustment function enables zero/span point adjustment work without using communicator. Set to any value an output corresponding to current input.

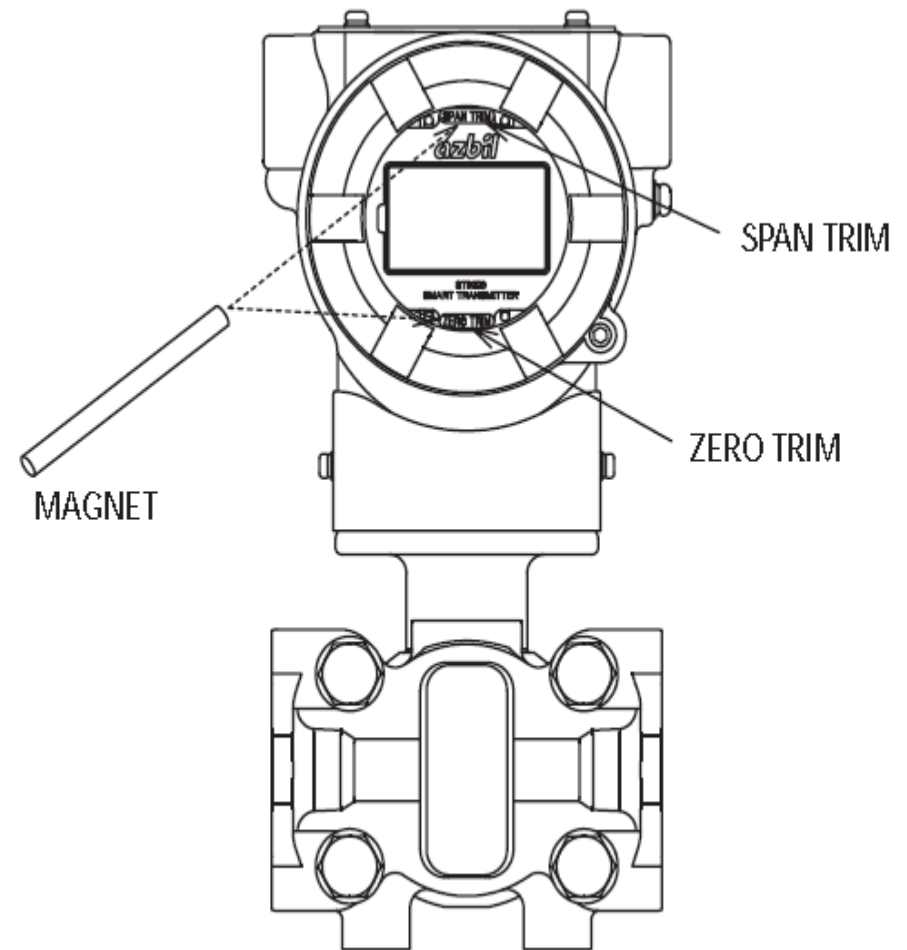

THIS FUNCTION IS OPTIONAL

External zero/span adjustment switch *azbil*

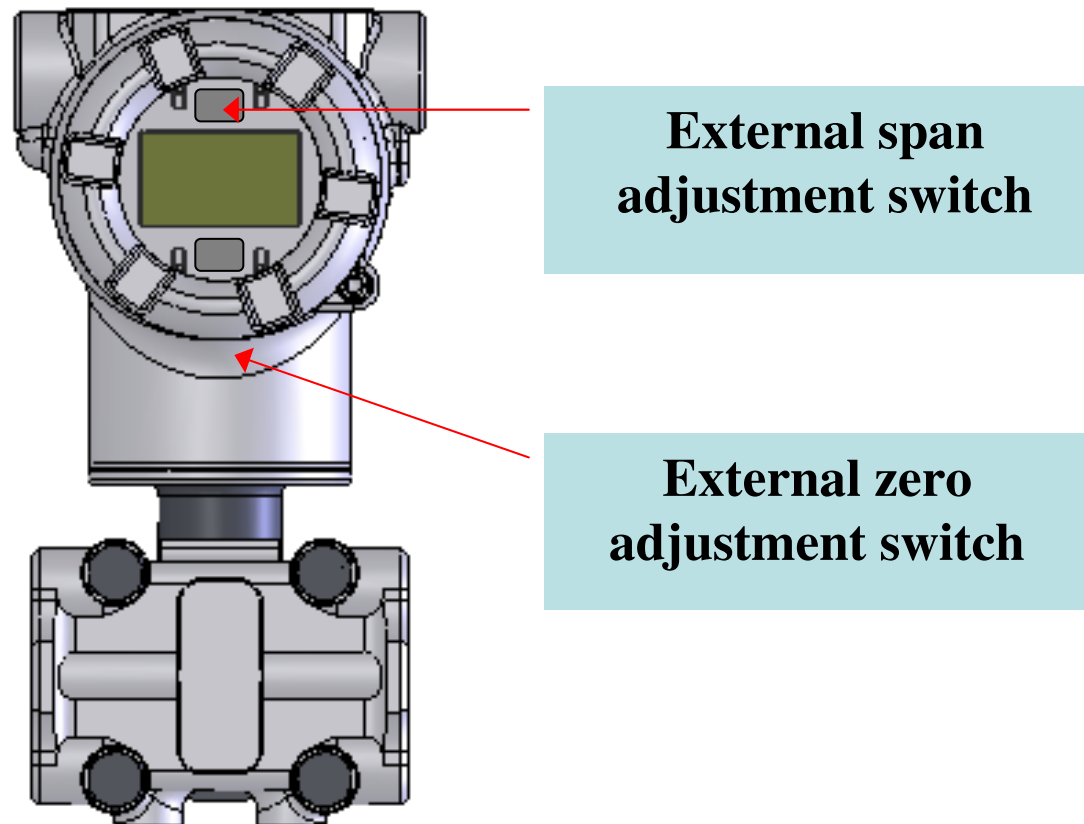

Easy to adjustment to touch with magnetic stick without opening the case-cover.

Procedure

How to adjust zero point.:

STEP	Procedure
1	Make sure that the zero pressure is applied to the transmitter.
2	Touch the magnet on the grass at the ZERO TRIM point for 3 seconds or more. And remove it when ammeter reading equals 4mA.

How to adjust span point.:

STEP	Procedure
1	Make sure that the desired upper range value pressure is applied to the transmitter.
2	Touch the magnet on the grass at the SPAN TRIM point for 3 seconds or more. And remove it when ammeter reading equals 20mA.

1. GTX Hardware
- 2. Identification & Model Selection**
3. Wiring and installation
4. Configuration & CNF100
5. Hands-on-training

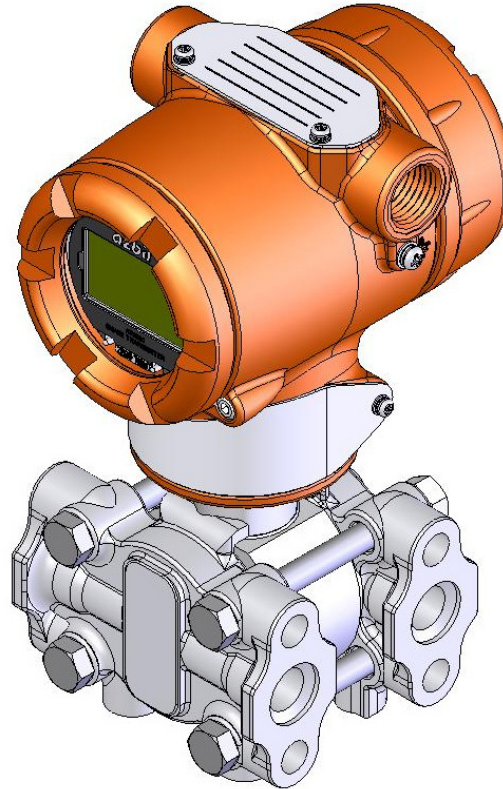

Please identify the unit in front of you by using the Model selection guide (Chapter 2)

1. GTX Hardware
2. Identification & Model Selection
- 3. Wiring and installation**
4. Configuration & CNF100
5. Hands-on-training

Wiring and Installation

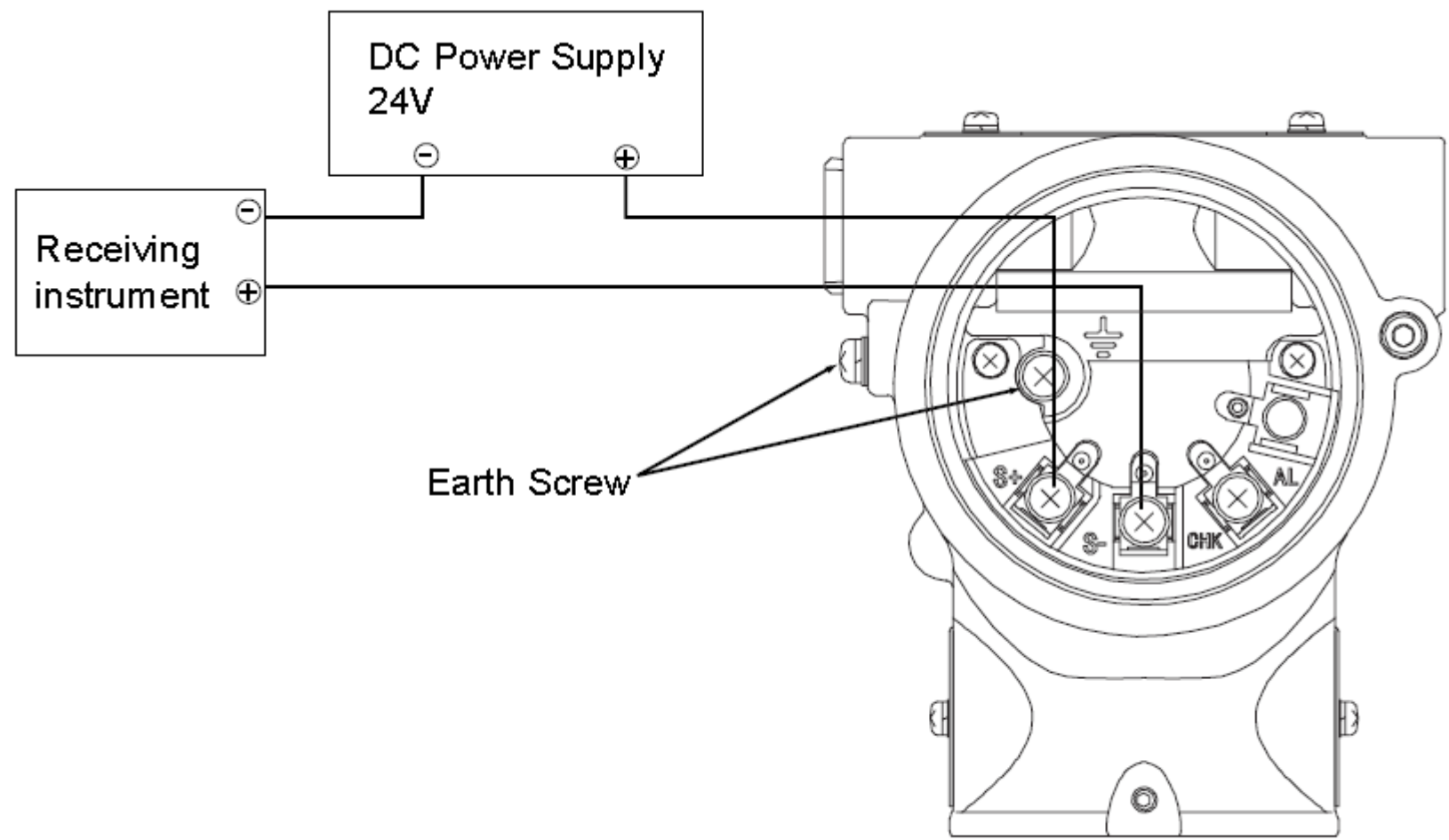

Wiring for transmitter without Alarm output

Wiring and Installation

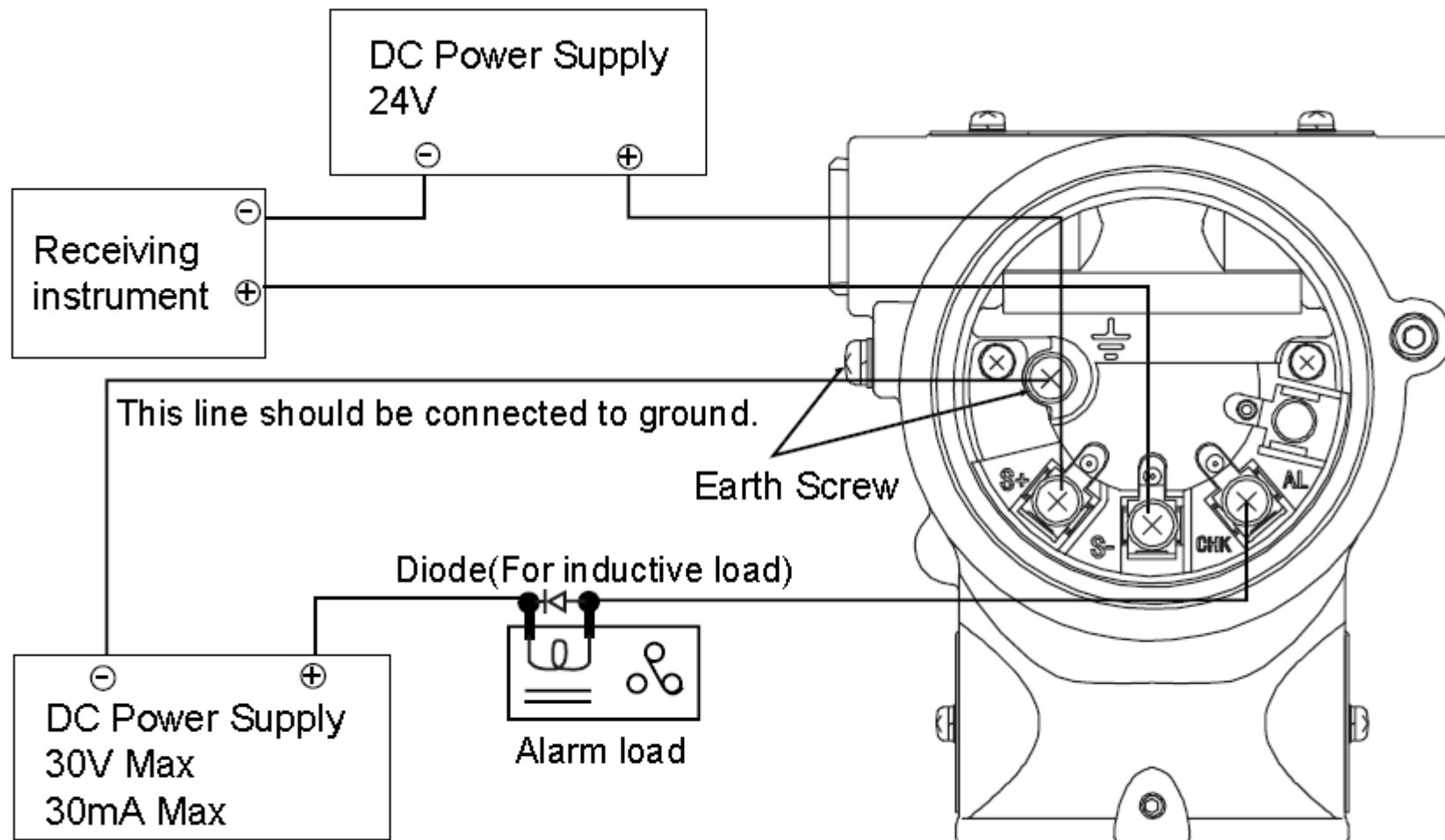

Wiring for transmitter with Alarm output

1. GTX Hardware
2. Identification & Model Selection
3. Wiring and installation
- 4. Configuration & CNF100**
5. Hands-on-training

Procedure for CNF100 Upgrade:

Download the ZIP-file from the following location:

http://www.yamatake.com/products/bi/iap/products/product_19.html

To upgrade CommPad's software, simply download and install the latest version from this site. Be sure to download and read the latest installation manual as well.

Latest version:



Installation manual:

[CommPad SW install.pdf](#) 

Copy the CE directory to the SD card when you unzipped the zip-file.

Insert the SD-card in the slot of the PDA and turn it on.

Then follow the instructions on the screen.

We recommend to run the Auto Restore tool after the installation. This will avoid the loss of the program after power failure.

Configuration & CNF100

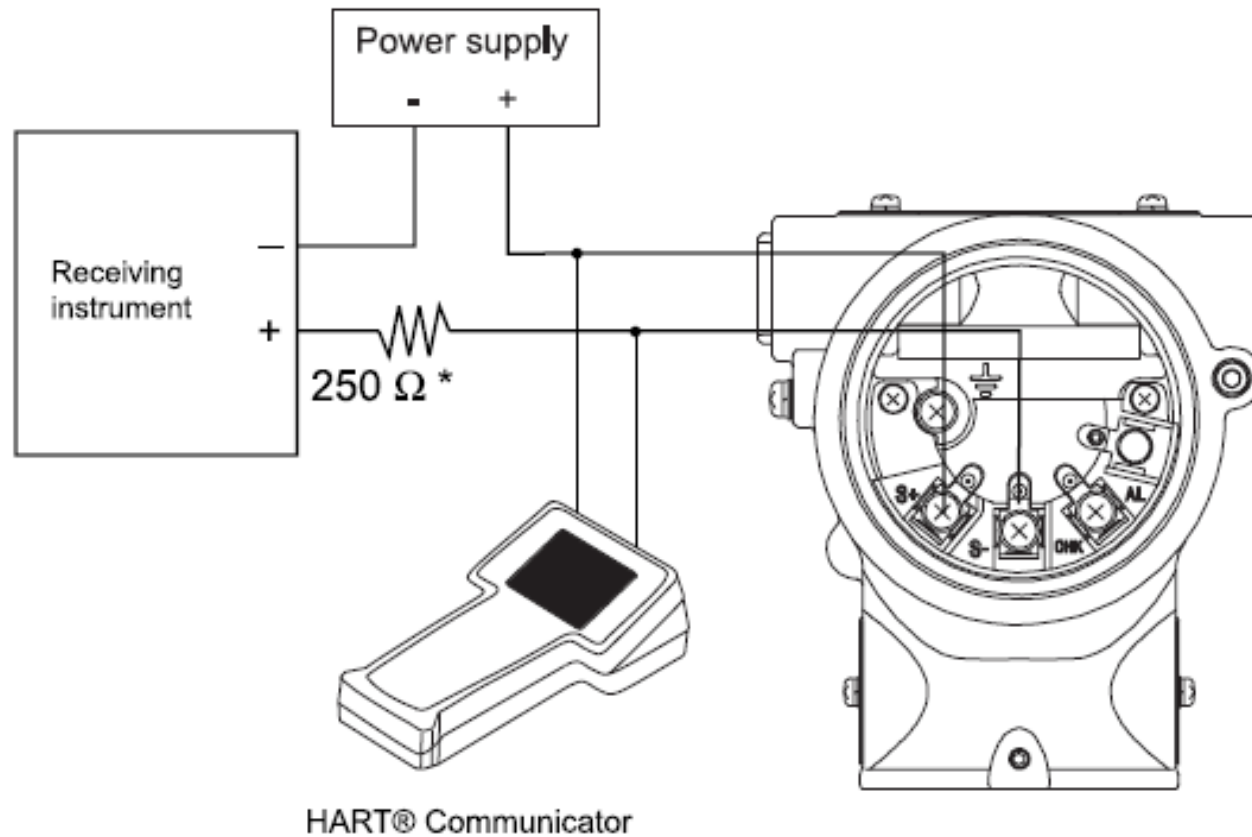

Configuration & CNF100

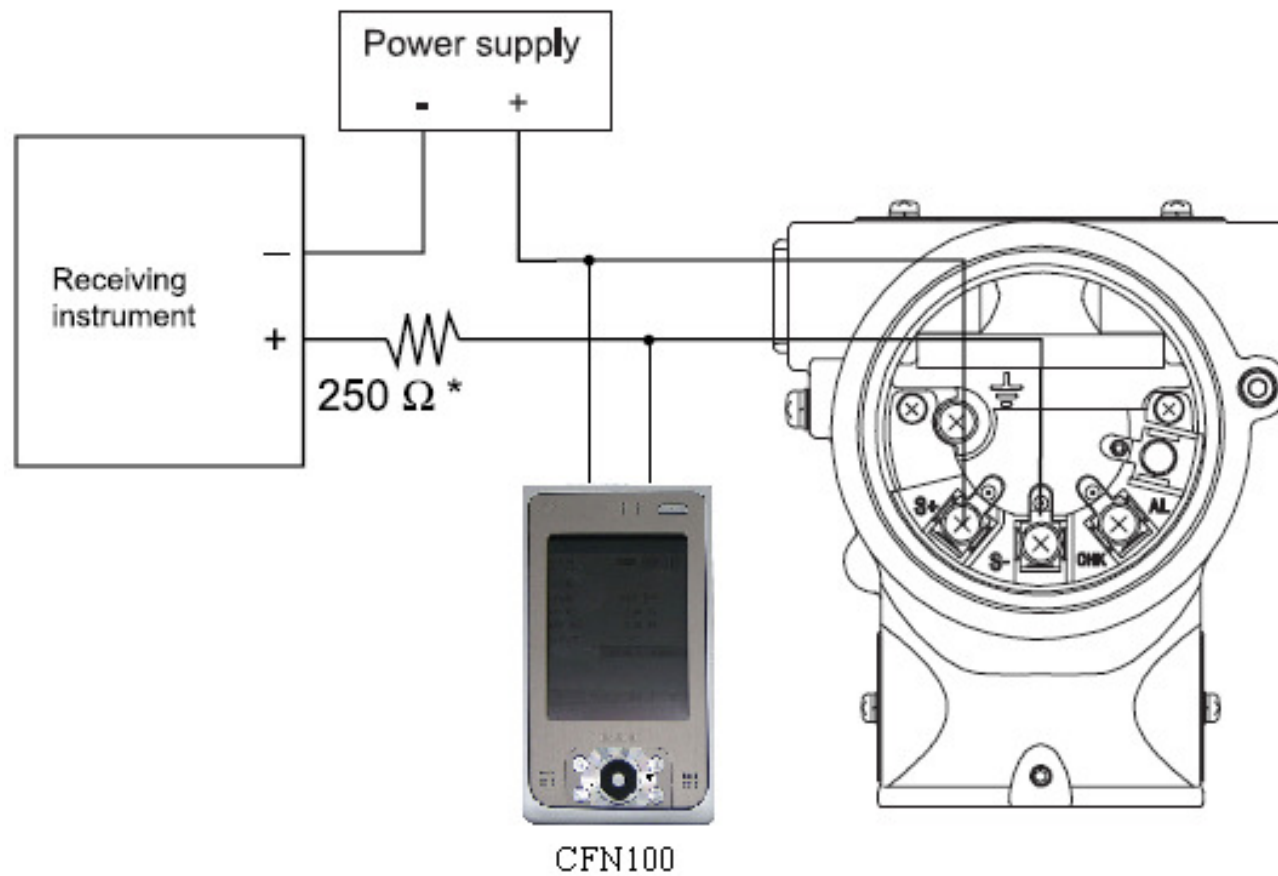

- The CNF100 will start up in monitoring Mode
- Following menu is visible on the screen:

Home	Summary	Config.	Settings
------	---------	---------	----------

Home	Summary	Config.	Settings
------	---------	---------	----------

- Home:

Brings the user back to the startup where different users can be selected.

- Summary:

Brings the user back to the monitoring mode.

Configuration & CNF100



Home	Summary	Config.	Settings
------	---------	---------	-----------------

Date
User
Device
Tag
Type
Conformity
PROM No.
SW Version
Damping
Span
LRV (0%)
URV (100%)
URL
F/S Dir.
Standard
Disp. Unit

O.L.LO
O.L.HI
Output Alarm
Lower Limit (Output Alarm)
Upper Limit (Output Alarm)
Sensor Temp. Alarm
Lower Limit Sensor Temp. Alarm
Upper Limit Sensor Temp. Alarm

Contact Output
Circuit Status
Present status
Write-protect by software
Write-protect by hardware
Output
Input
Sensor Temp. Status

-
- Settings

Actual status of settings and readings of the GTX
 - Save/Open

There's a possibility to save the current settings or to load saved settings.

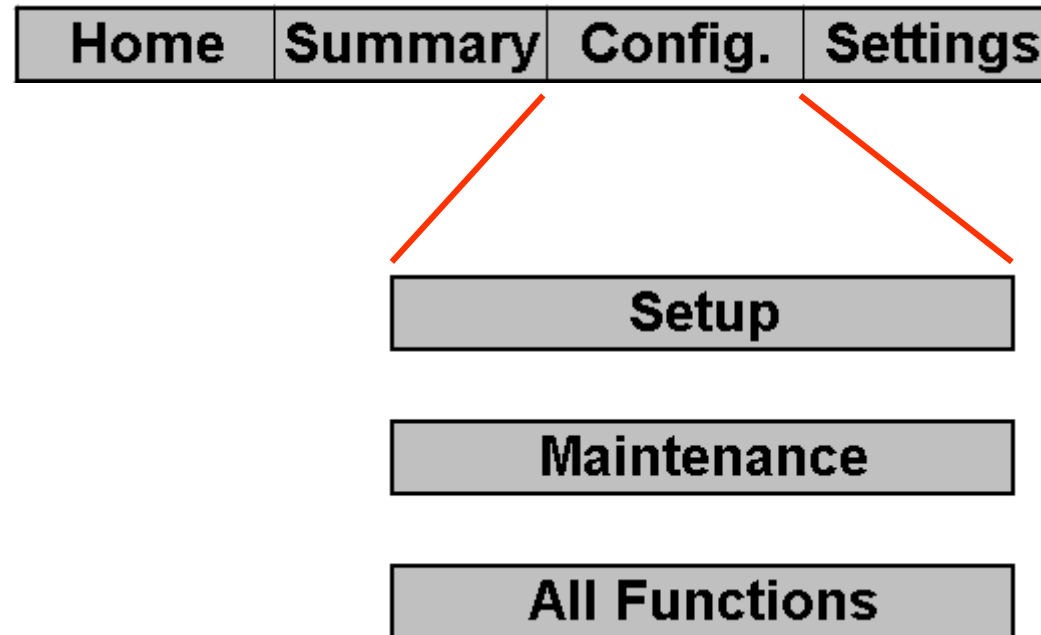

- **All Functions:** Collection of all options of Setup and Maintenance

Configuration & CNF100



Setup

Tag
Range
Remote seal
Display
Damping
Conformity
Fail-safe Dir
Output Limit
Memo
Monitoring

Maintenance

Monitoring
Adjustment
Calibration
Output Mode
4-20mA Correct
Memo
PROM No
Software Version
Records

Configuration & CNF100



All Functions

Tag
Conformity
Range
Damping
Monitoring
Output Mode
4-20mA Correct
Adjustment
Calibration
Memo

Display
Fail-safe Dir.
Output Limit
Remote seal
PROM No.
Software Version
Sensor Temp.
Records
Alarm/Contact Output
Data Overwrite Protection

- **Tag:** Name of the unit
- **Conformity:** Linear
Square root; Cutoff + Dropout settings
- **Range:** Lower Range Value (0%)
Upper Range Value (100%)
Setting of the units (mbar, psi, atm, mmHg,...)
- **Monitoring:** Reading of the actual values and LRV-URV settings.
- **Output Mode:** Setting of the analog output; simulating signals of 4mA (0%), 8mA (25%), 12mA (50%), 16mA (75%), 20mA (100%) or any value.

-
- 4-20mA Correct
 - Adjustment
 - Calibration Setting of Zero Input; Correct LRV / URV; Restore Factory Settings or rest corrections.
 - Memo Possibility to enter a memo with a maximum of 16 characters

- Damping:

Means a response time of the primary time lag (63.2% response) for a stepresponse of the pressure. If the out fluctuations are large, increase the damping. A large damping value stabilizes the output but lowers the response performance.

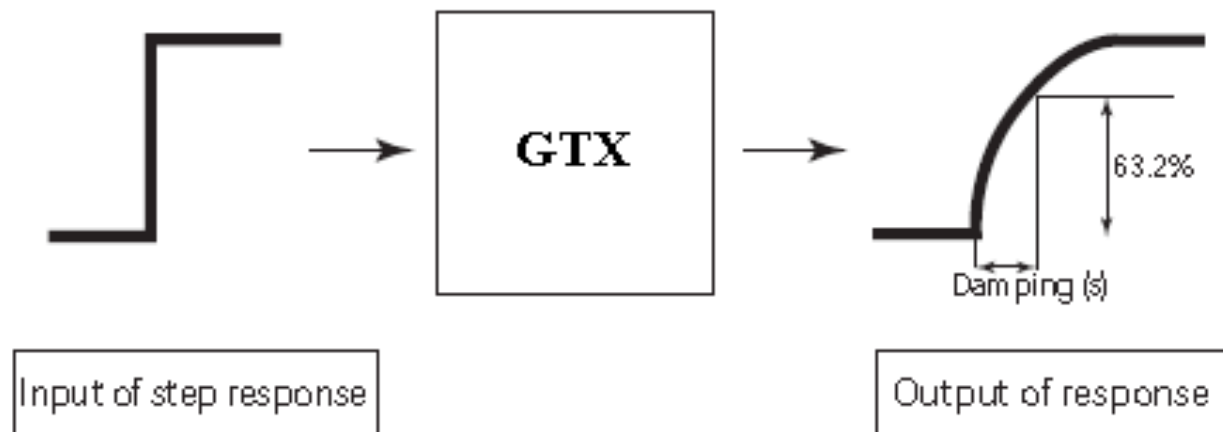

- **Display:** Select unit mode: %
 - Actual pressure (SI-units)
 - Engineering units

- Engineering units: Display conformity – Linear
 - Square root
 - Square root; Setting of EULO / EUHI
 - Setting of Exponent
 - Setting of Unit or User-defined unit

- **Fail-safe:** Failure Alarm Simulation Mode
 - Simulation of an alarm; this alarm is also shown on the display of the GTX

- Records

 - Log zero calibrations

 - Status records; Failure Alarm

 - Simulation Mode

- Alarm/Contact Output

 - Configuration of the output alarms;

 - None, Upper, Lower, Upper/Lower

 - Sensor Temp. Alarm;

 - None, Upper, Lower, Upper/Lower

 - Contact Output Alarm ON/OFF

 - None, Output Alarm, Sensor Temp. Alarm, Output/Sensor Temp.

 - Circuit Status: Open / Closed

 - Contact Output Simulation Mode:

 - Simulation to check the contact outputs.

- Data Overwrite Protection:

- Software Write protect ON/OFF
 - Status of Hardware Write Protect

Questions ?