

AT9000 Advanced Transmitter

Remote-sealed type of Pressure Transmitters

OVERVIEW

AT9000 Advanced Transmitter is a microprocessor-based smart transmitter that features high performance and excellent stability. Capable of measuring gas, liquid, vapor, and liquid levels, it transmits 4 to 20 mA DC analog and digital signals according to the measured pressure. It can also execute two-way communications between the CommPad (Handy Communicator) or HART[®] 375 communicator, thus facilitating self-diagnosis, range resetting, and automatic zero adjustment.



FEATURES

Excellent stability and high performance

- Long-term stability is proven in 500,000 installations worldwide.
- Unique characterization and composite semiconductor sensors realize excellent temperature and static pressure characteristics.

A diverse lineup

- A diverse flange lineup, ranging from small diameter 1.5 inch (40 mm) and 2 inches (50 mm) to 3 inches (80 mm), is available to meet user requirements.
- A wide range of models, including those for general purposes, high-temperature, and high-temperature and high-vacuum service, is available to meet user requirements. In addition, the working temperature range of regular type has been expanded to 180°C maximum to allow you greater freedom instrumentation.
- A wide variety of corrosion-resistant materials for wetted parts is also available.

Remote communication

- Two-way communication using digital output facilitates self-diagnosis, range resetting, automatic zero adjustment, and other operations.
- HART[®] protocol communication is available. (Option)

China RoHS

This device is used in the Oil & Gas, Petrochemical, Chemical, Pulp & Paper, Food & Beverage, Machinery, Steel/Metal & Mining, and Automobile industries and therefore does not fall under the China RoHS Legislation.

If this device is used in semiconductor manufacturing equipment, labeling on the device and documents for the China RoHS may be required. If such documents are required, consult a Yamatake representative.

HART[®] is a registered trademark of the HART Communication Foundation.

APPLICATION**Petroleum / Petrochemical / Chemical**

- For the measurement of liquid levels including corrosive fluids at high temperatures, and high temperatures under vacuum.
- For the measurement of liquid levels in small tanks.

Electric power / City gas / Other utilities

For measurement applications that require high degrees of stability and accuracy.

Pulp and paper

- For lines that need transmitters resistant to chemical liquids, corrosive fluids and the like.
- For the measurement of liquid levels in small tanks.

Iron and steel / Nonferrous metal / Ceramics

For lines that require stable measurement under strictly controlled (temperature, humidity, etc.) conditions.

Machinery / Shipbuilding

For lines that require stable measurement under strictly controlled (temperature, humidity, vibration, etc.) conditions.

FUNCTIONAL SPECIFICATIONS**FM Explosionproof and Dust Approvals (Code F1)**

Explosionproof for Class I, Division 1, Groups A, B, C and D; Class I, Zone 1, AEx d IIC
Dust-Ignitionproof for Class II, III, Division 1, Groups E, F and G

T5 $-40^{\circ}\text{C} \leq \text{Tamb} \leq +85^{\circ}\text{C}$

Hazardous locations

Indoor / Outdoor Type 4X, IP67

Factory sealed, conduit seal not required for Division applications

Caution - Use supply wires suitable for 5°C above surrounding ambient

FM Intrinsically safe Approval (Code F2)

IS/I,II,III/1/ABCDEFGH/T4; $-40^{\circ}\text{C} \leq \text{Tamb} \leq +60^{\circ}\text{C}$; 80395278, 80395279, 80395280; Entity; TYPE 4X; IP67
I/0/ AEx ia/IIC/T4; $-40^{\circ}\text{C} \leq \text{Tamb} \leq +60^{\circ}\text{C}$; 80395278, 80395279, 80395280; Entity; TYPE 4X; IP67
Entity Parameters: $V_{\text{max}}(U_i)=30$ Volts, $I_{\text{max}}(I_i)=100\text{mA}$, $P_i=1\text{W}$, $C_i=10\text{nF}$, $L_i=0.5\text{mH}$

FM Nonincendive Approval (Code F5)

NI/I/2/ABCD/T4; $-40^{\circ}\text{C} \leq \text{Tamb} \leq +60^{\circ}\text{C}$; 80395494; NIFW; TYPE 4X; IP67

NI/I/2/IIC/T4; $-40^{\circ}\text{C} \leq \text{Tamb} \leq +60^{\circ}\text{C}$; 80395494; NIFW; TYPE 4X; IP67

S/II,III/1/EFG/T4; $-40^{\circ}\text{C} \leq \text{Tamb} \leq +60^{\circ}\text{C}$; 80395494; NIFW; TYPE 4X; P67

Nonincendive Field Wiring Parameters: $V_{\text{max}}(U_i)=30$ Volts, $C_i=10\text{nF}$, $L_i=0.5\text{mH}$

Combination of F1, F2 and F5 (Code F6)**ATEX Flameproof and Dust Certifications (Code A1)**

CE 0344

Ex KEMA 08ATEX0004

II 1/2 G Ex d IIC T6 Tprocess= 85°C

$-30^{\circ}\text{C} \leq \text{Tamb} \leq +75^{\circ}\text{C}$ IP66/67

II 1/2 G Ex d IIC T5 Tprocess= 100°C

$-30^{\circ}\text{C} \leq \text{Tamb} \leq +80^{\circ}\text{C}$ IP66/67

II 1/2 G Ex d IIC T4 Tprocess= 110°C

$-30^{\circ}\text{C} \leq \text{Tamb} \leq +80^{\circ}\text{C}$ IP66/67

II 2 D Ex tD A21 IP66/67 T85 Tprocess= 85°C

$-30^{\circ}\text{C} \leq \text{Tamb} \leq +75^{\circ}\text{C}$

II 2 D Ex tD A21 IP66/67 T100 Tprocess= 100°C

$-30^{\circ}\text{C} \leq \text{Tamb} \leq +75^{\circ}\text{C}$

II 2 D Ex tD A21 IP66/67 T110 Tprocess= 110°C

$-30^{\circ}\text{C} \leq \text{Tamb} \leq +75^{\circ}\text{C}$

Caution - Use supply wires suitable for 5°C above surrounding ambient

ATEX Intrinsic safety and Dust Certifications (Code A2)

CE 0344

Ex KEMA 07ATEX0200 X

II 1 G Ex ia IIC T4 TPROCESS = 105°C

$-30^{\circ}\text{C} \leq \text{Tamb} \leq +60^{\circ}\text{C}$ IP66 / 67

ELECTRICAL PARAMETERS: $U_i = 30$ V, $I_i = 93$ mA,

$P_i = 1$ W, $C_i = 5$ nF, $L_i = 0.5$ mH

II 1 D Ex iaD 20 IP66 / 67 T105 TPROCESS = 105°C

$-30^{\circ}\text{C} \leq \text{Tamb} \leq +60^{\circ}\text{C}$

ATEX Type n and Dust Certifications (Code A5)

CE 0344

Ex KEMA 07ATEX0200 X

II 3 G Ex nL IIC T4 TPROCESS = 105°C

$-30^{\circ}\text{C} \leq \text{Tamb} \leq +60^{\circ}\text{C}$ IP66 / 67

ELECTRICAL PARAMETERS: $U_i = 30$ V, $C_i = 5$ nF, $L_i = 0.5$ mH

II 2 D Ex tD A21 IP66 / 67 T85 TPROCESS = 85°C

$-30^{\circ}\text{C} \leq \text{Tamb} \leq +75^{\circ}\text{C}$

II 2 D Ex tD A21 IP66 / 67 T100 TPROCESS = 100°C

$-30^{\circ}\text{C} \leq \text{Tamb} \leq +80^{\circ}\text{C}$

II 2 D Ex tD A21 IP66 / 67 T110 TPROCESS = 110°C

$-30^{\circ}\text{C} \leq \text{Tamb} \leq +80^{\circ}\text{C}$

NEPSI Flameproof and Dust Certifications (Code N1)

Ex d IIC T6 DIP A21 T_A 85°C Tprocess= 80°C $-40^{\circ}\text{C} \leq \text{Tamb} \leq +75^{\circ}\text{C}$

Ex d IIC T5 DIP A21 T_A 100°C Tprocess= 95°C $-40^{\circ}\text{C} \leq \text{Tamb} \leq +80^{\circ}\text{C}$

Ex d IIC T4 DIP A21 T_A 115°C Tprocess= 110°C $-40^{\circ}\text{C} \leq \text{Tamb} \leq +80^{\circ}\text{C}$

ENCLOSURE TYPE IP66/67

NEPSI Intrinsic Safety Certification (Code N2)

Ex ia IIC T4 Tprocess= 105°C $-40^{\circ}\text{C} \leq \text{Tamb} \leq +60^{\circ}\text{C}$

Enclosure IP66 / 67

Electrical Parameters: $U_i=30\text{V}$, $I_i=100\text{mA}$, $P_i=1\text{W}$,

$C_i=13\text{nF}$, $L_i=0.5\text{mH}$

NEPSI Type n Certification (Code N5)

Ex nL IIC T4 Tprocess= 110°C $-40^{\circ}\text{C} \leq \text{Tamb} \leq +60^{\circ}\text{C}$

Enclosure IP66 / 67

Electrical Parameters: $U_i=30\text{V}$, $I_i=100\text{mA}$, $P_i=1\text{W}$,

$C_i=13\text{nF}$, $L_i=0.5\text{mH}$

IECEX Flameproof and Dust Certifications (Code E1)

Certificate No. IECEX KEM 08.0001
 Ga/Gb Ex d IIC T6 Tprocess=85°C -30°C ≤ Tamb ≤ +75°C IP66/67
 Ga/Gb Ex d IIC T5 Tprocess=100°C -30°C ≤ Tamb ≤ +80°C IP66/67
 Ga/Gb Ex d IIC T4 Tprocess=110°C -30°C ≤ Tamb ≤ +80°C IP66/67
 Ex tD A21 IP66/67 T85 Tprocess=85°C -30°C ≤ Tamb ≤ +75°C
 Ex tD A21 IP66/67 T100 Tprocess=100°C -30°C ≤ Tamb ≤ +75°C
 Ex tD A21 IP66/67 T110 Tprocess=110°C -30°C ≤ Tamb ≤ +75°C
 Caution - Use supply wires suitable for 5°C above surrounding ambient

IECEX Intrinsic safety and Dust Certifications (Code E2)

IECEX KEM 07.0058X
 Zone 0 Ex ia IIC T4 TPROCESS = 105 °C
 -30 °C ≤ Tamb ≤ +60 °C IP66 / 67
 ELECTRICAL PARAMETERS: Ui = 30 V, Ii = 93 mA, Pi = 1 W, Ci = 5 nF, Li = 0.5 mH
 Ex iaD 20 IP66 / 67 T105 TPROCESS = 105 °C
 -30 °C ≤ Tamb ≤ +60 °C

IECEX Type n and Dust Certifications (Code E5)

IECEX KEM 07.0058X
 Ex nL IIC T4 TPROCESS = 105 °C
 -30 °C ≤ Tamb ≤ +60 °C IP66 / 67
 ELECTRICAL PARAMETERS: Ui = 30 V, Ci = 5 nF, Li = 0.5 mH
 Ex tD A21 IP66 / 67 T85 TPROCESS = 85 °C
 -30 °C ≤ Tamb ≤ +75 °C
 Ex tD A21 IP66 / 67 T100 TPROCESS = 100 °C
 -30 °C ≤ Tamb ≤ +80 °C
 Ex tD A21 IP66 / 67 T110 TPROCESS = 110 °C
 -30 °C ≤ Tamb ≤ +80 °C

EMC Conformity

89/336/EEC, 92/31/EEC, 93/68/EEC Electromagnetic

PED Conformity (97/23EC)

The maximum pressures applicable under the Sound Engineering Practice (SEP) section of the Pressure Equipment Directive depend on the type of fluid measured, as shown in the table below.

Measured fluid	Group *	Pressure	Applicable models
Gas	1	200 bar (20 MPa)	All models except GTX32D, 42D, 72D, 82G
	2	1,000 bar (100 MPa)	All models
Liquid	1	500 bar (50 MPa)	All models
	2	1,000 bar (100 MPa)	All models

Note) Group 1 comprises fluids defines as: explosive, extremely flammable, highly flammable, flammable, very toxic, toxic and oxidizing.
 Group 2 comprises all other fluids not refer to group 1

Measuring span / Setting range / Working pressure range

	Measuring Span	Setting Range	Working Pressure Range	Overload Resistant Value
GTX 35U	2.5 to 100 kPa {250 to 10160 mmH ₂ O}	-100 to 100 kPa {-10160 to 10160 mmH ₂ O}	Up to flange rating (For negative pressures, see Figures 1, 2 and 3.)	None
GTX 60U	35 to 3500 kPa {0.35 to 35kgf/cm ² }	-100 to 3500 kPa {-1 to 35 kgf/cm ² }	Up to flange rating (For negative pressures, see Figures 1, 2 and 3.)	5250 kPa {52.5 kgf/cm ² }
GTX 71U	0.7 to 10 MPa {7 to 102 kgf/cm ² }	-0.1 to 10 MPa {-1 to 102 kgf/cm ² }	Up to flange rating (For negative pressures, see Figures 1, 2 and 3.)	15.3 MPa {153 kgf/cm ² }
GTX 82U	0.7 to 42 MPa {7 to 420 kgf/cm ² }	-0.1 to 42 MPa {-1 to 420 kgf/cm ² }	Up to flange rating (For negative pressures, see Figures 1, 2 and 3.)	63MPa {630 kgf/cm ² }

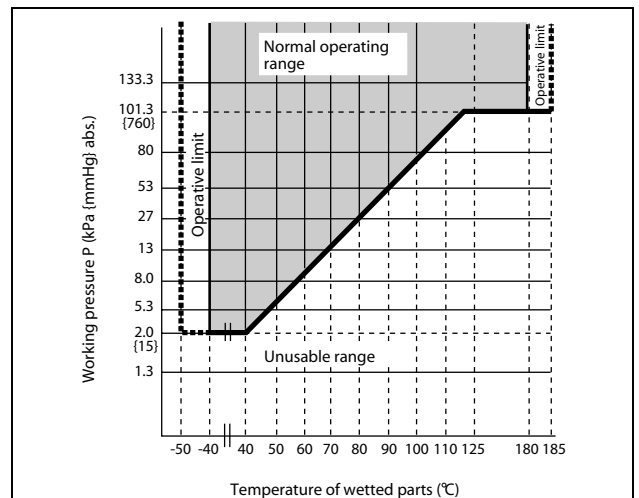

Figure 1 Working pressure and temperature of wetted parts section (for general purpose models)

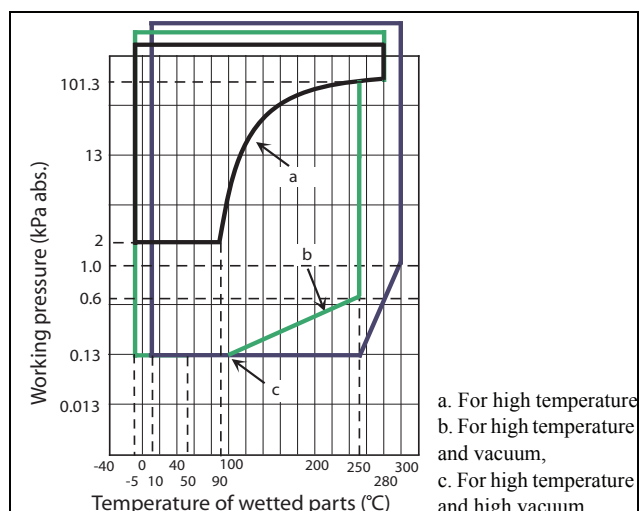
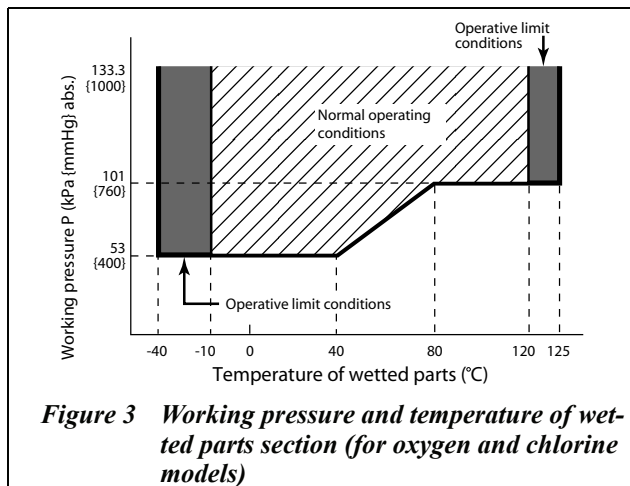

Figure 2 Working pressure temperature of wetted parts section (For high temperature / high temperature and vacuum / high temperature and high vacuum)



Supply voltage and load resistance

17.9 to 42V DC. A load resistance of 250 Ω or more is necessary between loops. See Figure 4.

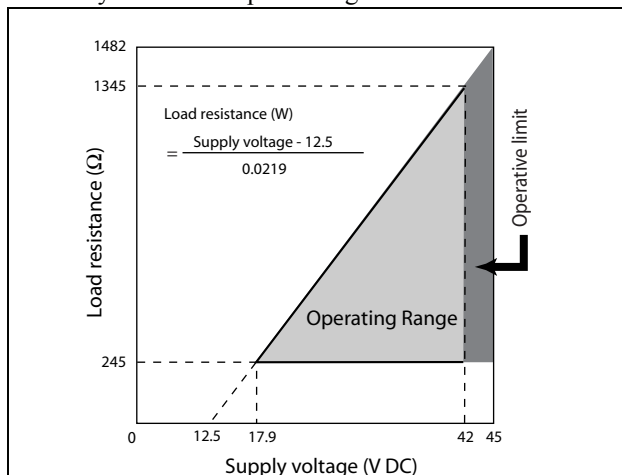

Figure 4 Supply voltage vs. load resistance characteristics

Note) For communication with SFC, a load resistance of 250 Ω or more is necessary.

Output

- Analog output (4 to 20 mA DC) with DE protocol
- Analog output (4 to 20 mA DC) with HART protocol
- Digital output (DE protocol)

Output signal

- 3.6 to 21.6 mA
- 3.8 to 20.5 mA (NAMUR NE43 compliant)

Failure Alarm

- Upper: 21.6 mA or more
- Lower: 3.6 mA or less

Ambient temperature limits / Temperature ranges of wetted parts

		Temperature range (°C) *1 *4				
		Regular type	High-temp. models	High-temp. Vacuum models	High-temp. High Vacuum models	Oxygen and Chlorine models
Wetted parts section	Normal operating range	-40 to 180	-5 to 280 *5	-5 to 280 *5	10 to 300 *5	-10 to 120
	Operative limit range	-50 to 185	-10 to 310 *6	-10 to 310 *6	-10 to 310 *6	-40 to 125
Ambient temperature *2 Flange size: Flush diaphragm type 3 inches (80 mm) Extended diaphragm type 4 inches (100 mm)	Normal operating range	-30 to 75	-5 to 55	-5 to 55	10 to 55	-10 to 75
	Operative limit range	-50 to 80	-10 to 60	-10 to 60	-10 to 60	-40 to 80
Ambient temperature Note 2 Flange size: Flush diaphragm type 2 inches (50 mm) / 1.5 inch (40 mm) Extended diaphragm type 3 inches (80 mm) / 2 inches (50 mm)	Normal operating range	-15 to 65	-5 to 45	-5 to 55	10 to 55	-10 to 75
	Operative limit range	-30 to 80	-10 to 55	-10 to 60	-10 to 60	-40 to 80
Specific gravity of fill liquid *3		0.935	1.07	1.07	1.09	1.87

Note) *1: See the working pressures and temperatures of the wetted parts section in Figure 1, Figure 2 and Figure 4.

*2: Ambient temperatures of the transmitter itself

*3: Approximate values at the temperature of 25°C

*4: Note that if the operating temperature falls below the lower limit of the normal operating range, the response of the transmitter becomes slower.

*5: When the wetted parts material is tantalum, the upper limit is 180°C.

*6: When the wetted parts material is tantalum, the upper limit is 200°C.

Flange size: 3/4inches (20mm), 1/2 inches (15mm)

		Temperature range (°C) *1 *4		
		Regular type	High-temp. models	Oxygen and chlorine models
Wetted parts section	Normal operating range	-40 to 180	-5 to 280	-10 to 120
	Operative limit range	-50 to 185	-10 to 310	-40 to 125
Ambient temperature *2	Normal operating range	-15 to 65	-5 to 45	-10 to 75
	Operative limit range	-30 to 80	-10 to 55	-40 to 80
Specific gravity of fill liquid *3		0.935	1.07	1.87

Note) *1: See the working pressures and temperatures of the wetted parts section in Figure 2, Figure 3 and Figure 4.

*2: Ambient temperatures of the transmitter itself.

*3: Approximate values at the temperature of 25°C.

*4: Note that if the operating temperature falls below the lower limit of the normal operating range, the response of the transmitter becomes slower.

For Explosion proof models with digital indicators, which have to be used within the following ranges

Normal operating condition

-20 to 70°C

Operative limit

-30 to 80°C

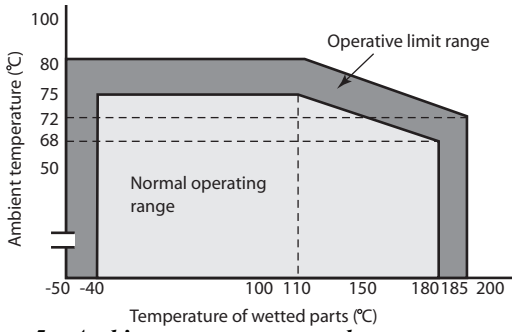

Figure 5 Ambient temperature and temperature of wetted parts section (for general purpose models)

[Flange size: Flush diaphragm 2 inches (50 mm) / 1.5 inch (40 mm)
Extended diaphragm 3 inches (80 mm) / 2 inches (50 mm)]

Note) When the fill liquid is for general purposes, make sure before using your transmitter that the conditions in both Figure 1, Figure 5 and Figure 6 are met.

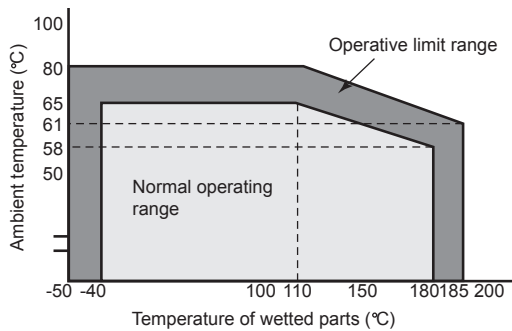

Figure 6 Ambient temperature and temperature of wetted parts section (for general purpose models)

[Flange size: Flush diaphragm 3 inches (80 mm)
Extended diaphragm 4 inches (100 mm)]

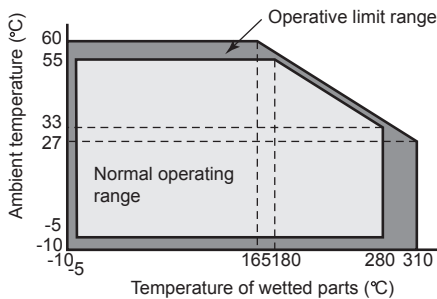

Figure 7 Ambient temperature and temperature of wetted parts section (for high temperature and vacuum 2, 3m)

[Flange size: Flush diaphragm 2 inches (50 mm) / 1.5 inch (40 mm)]

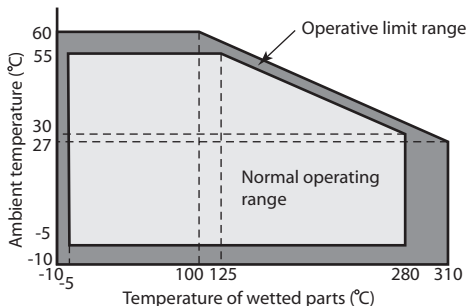

Figure 8 Ambient temperature and temperature of wetted parts section (for high temperature and vacuum 4, 5 m)

[Flange size: Flush diaphragm 2 inches (50 mm) / 1.5 inch (40 mm)]

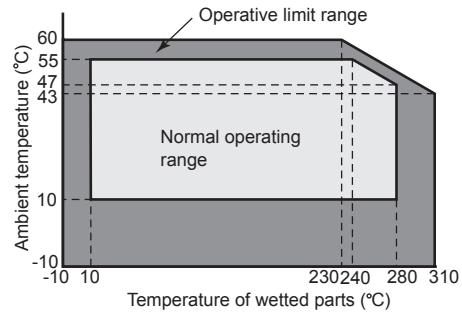

Figure 9 Ambient temperature and temperature of wetted parts section (for high temperature and high vacuum 2, 3 m)

[Flange size: Flush diaphragm 2 inches (50 mm) / 1.5 inch (40 mm)]

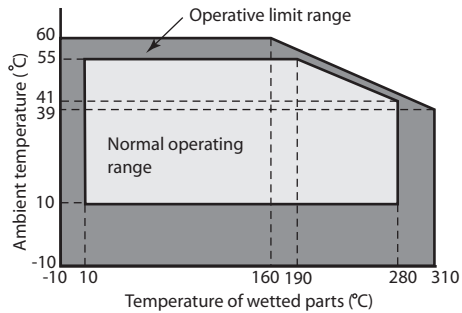

Figure 10 Ambient temperature and temperature of wetted parts section (for high temperature and high vacuum 4, 5 m)

[Flange size: Flush diaphragm 2 inches (50 mm) / 1.5 inch (40 mm)]

Ambient humidity limits

5 to 100% RH

Stability against supply voltage change

± 0.005% FS/V

Dead time

Max: 0.4 sec.

Damping time

Selectable from 0 to 32 sec. in ten stages

Lightning protection

Applicable Standards; IEC 61000-4-5

Peak value of current surge(80/20μ sec.): 6000A

Indicator

The digital LCD indicator (optional) indicates engineering units and can be set freely between -99999 and 99999 (5 digits). For meter calibration, specify the following items when placing your order.

- Meter calibration range
- Meter calibration unit
- Linear / Square-root for meter indication.

Various kinds of data can be set using the CommPad or the HART[®]375 communicator.

Bolts and nuts materials (for fastening meter body cover)

Carbon steel (SNB7), 304 SST, 630 SST

Paint

Standard

Corrosion-resistant paint (Baked acrylic paint)

Corrosion-proof finish

Corrosion-proof paint (Baked urethane paint), fungus-proof finish

Corrosion-resistant finish (silver color)

Transmitter case is coated with silver paint in addition to the above corrosion-resistant finish.

OPTIONAL SPECIFICATIONS**FEP protective film**

Use FEP protective films when corrosive fluids are used or to inhibition migration from metal diaphragms.

Working temperature range

0 to 110°C

Working pressure range

Atmospheric pressure to flange rating
(up to JIS10K, ANSI/JPI 150)
(Not usable under negative pressure)

Oil free finish

The transmitter is shipped with oil-free wetted parts.
(The vent drain plug is coated with a small amount of fluorine oil to prevent galling.)

External zero/span adjustment function

The transmitter can be easily zero/span adjusted in the field.

Elbow

This is an adaptor for changing the electrical conduit connection port from the horizontal to the vertical direction, if required by wiring conditions in the field. One or two elbows may be used as needed.

Conformance to SI units

We deliver transmitters set to any SI units as specified.

Safety Transmitter

Select this option to be used as a component of Safety Instrument System (SIS).

AT9000 is complied with IEC61508, certified according to Safety Integrity Level2 (SIL-2)

Alarm Output (contact output)

Contact output is prepared as alarm output when alarm (Output Alarm/Sensor Temp. Alarm) condition is detected. It can be set to Normally Open. (When alarm is detected, Contact ON).

Custom calibration

Calibrate for the specified pressure range at the factory.

PHYSICAL SPECIFICATIONS**Materials****Fill fluid**

Silicone oil for general purpose and high-temperature vacuum models

Fluorine oil for oxygen and chlorine models

For specific gravity, refer to "Ambient temperature limits / Temperature ranges of wetted parts" on page 5.

Center body

316 SST

Transmitter case

Aluminum alloy

Meter body cover

304 SST

For Wetted parts

316 SST (316L SST for diaphragm only)
ASTM B575 (Hastelloy C-276 equivalent), Tantalum,
316L SST

Flange materials

304 SST, 316 SST, 316L SST

Weight

Approx. 13.5 kg

(Including ANSI150 # - 3 inches flange and capillary 5 m long.)

INSTALLATION**Electrical connection**

1/2NPT internal thread, M20 internal thread.

Grounding

Resistance 100 Ω max.

Mounting

Direct mounting on the process side

Using 2-inch pipe mounting brackets: Mount the transmitter on a horizontal or vertical 2-inch pipe

Bracket

Carbon steel, 304 SST

U-bolt and nuts

304 SST

Process connection**Measured pressure (liquid side)**

Flanges (both higher and lower pressure sides)

Flush diaphragm

JIS 10K, 20K, 30K and 63K: 40, 50, 80mm(RF) equivalents
ANSI/JPI 150, 300 and 600: 1.5, 2, 3 inches (RF) equivalents
ANSI/JPI 150 and 300: 1/2, 3/4 inches (RF) equivalents

Extended diaphragm

JIS 10K, 20K and 30K: 50, 80, 100mm(RF) equivalents
ANSI/JPI 150, 300 and 600: 2, 3 inches (RF) equivalents
ANSI/JPI 150 and 300: 4 inches (RF) equivalents

Flange standard

JIS; JIS B 2220 (2004)
ANSI; ANSI B 16.5 (1988)
JPI; JPI-7S-15-93

Screw connection

G1½ button diaphragm (G1½ external thread)

Mounting notes**For pressure measurement**

- 1) If the fluid to be measured contains hydrogen, please consult us.
- 2) When mounting the transmitter, leave a space of at least 10 cm under the upper nozzle of the tank. If the no space is available, please consult us.

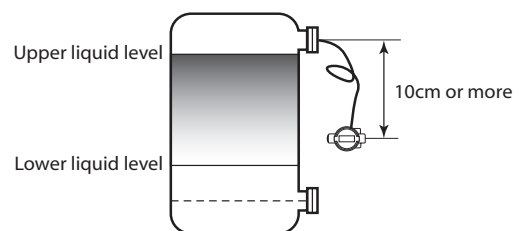
**⚠ WARNING**

- Impact to transmitter can damage sensor module.

PERFORMANCE SPECIFICATIONS

Max working pressure

- Note) 1. Max working pressure depends on flange rating, flange materials and operating temperature. Please refer to the following data. Operating range of temperature depends on specification of transmitters.
- Note) 2. In case of flange type (GTX60F) and remote scaled type (model GTX60U), max working pressure depends on the smaller value of either 1.5 MPa or following data.
- Note) 3. In case of remote scaled type (model GTX71U), max working pressure depends on the smaller value of either 10 MPa or following data.

	JIS	JPI/ANSI
304 SST		
316 SST		
316L SST		

Reference accuracy

Shown for each item are the percentage ratio for χ (kPa), which is the greatest value of either the upper range value (URV)^{*1}, the lower range value (LRV)^{*2} or the span.

Model GTX35U (for regular type / high-temperature / oxygen service)

Material of wetted parts: 316 SST (Diaphragm; 316L SST), 316L SST

Flange size: Flush diaphragm 3 inches (80 mm) Extended diaphragm 4 inches (100 mm)

Reference accuracy(*4)	$\pm 0.2\%$ (For $\chi \geq 12.5$ kPa {1250 mmH ₂ O})
	$\pm \left(0.05 + 0.15 \times \frac{12.5}{\chi}\right) \%$ (For $\chi < 12.5$ kPa {1250 mmH ₂ O})
Ambient Temperature effect (Shift from the set range) Change of 30°C (Range from -5 to 55°C)	Combined shift: $\pm 1.3\%$ (For $\chi \geq 25$ kPa {2500 mmH ₂ O}) (including zero and span shifts)
	$\pm \left(0.8 + 0.5 \times \frac{25}{\chi}\right) \%$ (For $\chi < 25$ kPa {2500 mmH ₂ O})

Model GTX35U (for regular type / high-temperature / oxygen / chlorine service)

Material of wetted parts: ASTM B575 (Hastelloy C-276 equivalent), Tantalum

Flange size: Flush diaphragm 3 inches (80 mm)

Reference accuracy (*3)(*4)	$\pm 0.3\%$ (For $\chi \geq 12.5$ kPa {1250 mmH ₂ O})
	$\pm \left(0.15 + 0.15 \times \frac{12.5}{\chi}\right) \%$ (For $\chi < 12.5$ kPa {1250 mmH ₂ O})
Ambient Temperature effect (Shift from the set range) Change of 30°C (*3) (Range from -5 to 55°C)	Combined shift: $\pm 4.5\%$ (For $\chi \geq 25$ kPa {2500 mmH ₂ O})
	$\pm \left(1.5 + 3.0 \times \frac{25}{\chi}\right) \%$ (For $\chi < 25$ kPa {2500 mmH ₂ O})

Model GTX35U (for regular type and high-temperature / oxygen service)
(For option "M5", 0.1mm thickness diaphragm)

Material of wetted parts: 316 SST (Diaphragm; 316L SST), 316L SST

Flange size: Flush diaphragm 3 inches (80 mm) Extended diaphragm 4 inches (100 mm)

Reference accuracy(*4)	$\pm 0.4\%$ (For $\chi \geq 12.5$ kPa {1250 mmH ₂ O})
	$\pm \left(0.1 + 0.3 \times \frac{12.5}{\chi}\right) \%$ (For $\chi < 12.5$ kPa {1250 mmH ₂ O})
Ambient Temperature effect (Shift from the set range) Change of 30°C (Range from -5 to 55°C)	Combined shift: $\pm 5.2\%$ (For $\chi \geq 25$ kPa {2500 mmH ₂ O}) (including zero and span shifts)
	$\pm \left(3.2 + 2.0 \times \frac{25}{\chi}\right) \%$ (For $\chi < 25$ kPa {2500 mmH ₂ O})

Model GTX60U (for regular type / high-temperature / oxygen service)

Material of wetted parts: 316 SST (Diaphragm; 316L SST), 316L SST

Flange size: Flush diaphragm 3 inches (80 mm) Extended diaphragm 4 inches (100 mm)

Reference accuracy (*4)	$\pm 0.2\%$ (For $\chi \geq 350$ kPa {3.5 kgf/cm ² })
	$\pm \left(0.05 + 0.15 \times \frac{350}{\chi}\right) \%$ (For $\chi < 350$ kPa {3.5 kgf/cm ² })
Ambient Temperature effect (Shift from the set range) Change of 30°C (*3) (Range from -5 to 55°C)	Combined shift: $\pm 0.57\%$ (For $\chi \geq 350$ kPa {3.5 kgf/cm ² })
	$\pm \left(0.19 + 0.38 \times \frac{350}{\chi}\right) \%$ (For $\chi < 350$ kPa {3.5 kgf/cm ² })

Note) *1: URV denotes the process value for 100% (20mA DC) output

*2: LRV denotes the process value for 0% (4mA DC) output.

*3: Within a range of URV ≥ 0 and LRV ≥ 0 .

*4: Reference accuracy at calibrated condition.

Model GTX60U (for regular type / high-temperature / oxygen service)

Material of wetted parts: 316 SST (Diaphragm; 316L SST), 316L SST

Flange size: Flush diaphragm 2 inches (50 mm), Extended diaphragm 3 inches (80 mm), 2 inches wafer

Reference accuracy (*3)(*4)		$\pm 0.2\%$	(For $\chi \geq 350$ kPa {3.5 kgf/cm ² })
		$\pm \left(0.05 + 0.15 \times \frac{350}{\chi}\right) \%$	(For $\chi < 350$ kPa {3.5 kgf/cm ² })
Ambient Temperature effect (Shift from the set range) Change of 30°C (*3) (Range from -5 to 55°C)	Combined shift:	$\pm 0.57\%$	(For $\chi \geq 350$ kPa {3.5 kgf/cm ² })
		$\pm \left(0.19 + 0.38 \times \frac{350}{\chi}\right) \%$	(For $\chi < 350$ kPa {3.5 kgf/cm ² })

Model GTX60U (for regular type / high-temperature / oxygen service)

Material of wetted parts: 316 SST (Diaphragm; 316L SST), 316L SST

Flange size: Flush diaphragm 1.5 inch, 3/4 inches (20 mm), 1/2 inches (15 mm), Extended diaphragm 2 inches (50mm)

Reference accuracy (*3)(*4)		$\pm 0.3\%$	(For $\chi \geq 350$ kPa {3.5 kgf/cm ² })
		$\pm \left(0.15 + 0.15 \times \frac{350}{\chi}\right) \%$	(For $\chi < 350$ kPa {3.5 kgf/cm ² })
Ambient Temperature effect (Shift from the set range) Change of 30°C (*3) (Range from -5 to 55°C)	Combined shift:	$\pm 0.57\%$	(For $\chi \geq 350$ kPa {3.5 kgf/cm ² })
		$\pm \left(0.19 + 0.38 \times \frac{350}{\chi}\right) \%$	(For $\chi < 350$ kPa {3.5 kgf/cm ² })

Model GTX60U (for high temperature and vacuum / high temperature and high vacuum)

Material of wetted parts: 316 SST (Diaphragm; 316L SST), 316L SST

Flange Size: Flush diaphragm 3 inches (80 mm) Extended diaphragm 4 inches (100 mm)

Reference accuracy (*3)(*4)		$\pm 0.2\%$	(For $\chi \geq 350$ kPa {3.5 kgf/cm ² })
		$\pm \left(0.05 + 0.15 \times \frac{350}{\chi}\right) \%$	(For $\chi < 350$ kPa {3.5 kgf/cm ² })
Ambient Temperature effect (Shift from the set range) Change of 30°C (*3) (Range from -5 to 55°C)	Combined shift:	$\pm 0.9\%$	(For $\chi \geq 350$ kPa {3.5 kgf/cm ² })
		$\pm \left(0.35 + 0.55 \times \frac{350}{\chi}\right) \%$	(For $\chi < 350$ kPa {3.5 kgf/cm ² })

Model GTX60U (for high temperature and vacuum / high temperature and high vacuum)

Material of wetted parts: 316 SST (Diaphragm; 316L SST), 316L SST

Flange Size: Flush diaphragm 2 inches (50 mm) / 1.5 inch (40 mm), Extended diaphragm 3 inches (80 mm) / 2 inches (50 mm), 2 inches wafer

Reference accuracy (*3)(*4)		$\pm 0.2\%$	(For $\chi \geq 350$ kPa {3.5 kgf/cm ² })
		$\pm \left(0.05 + 0.15 \times \frac{350}{\chi}\right) \%$	(For $\chi < 350$ kPa {3.5 kgf/cm ² })
Ambient Temperature effect (Shift from the set range) Change of 30°C (*3) (Range from -5 to 55°C)	Combined shift:	$\pm 0.9\%$	(For $\chi \geq 350$ kPa {3.5 kgf/cm ² })
		$\pm \left(0.35 + 0.55 \times \frac{350}{\chi}\right) \%$	(For $\chi < 350$ kPa {3.5 kgf/cm ² })

Note) *3: Within a range of URV ≥ 0 and LRV ≥ 0 .

*4: Reference accuracy at calibrated condition.

Model GTX60U (for regular type / high-temperature / oxygen service)**(For option "M5", 0.1mm thickness diaphragm)**

Material of wetted parts: 316 SST (Diaphragm; 316L SST), 316L SST

Flange size: Flush diaphragm 3 inches (80 mm) Extended diaphragm 4 inches (100 mm)

Reference accuracy (*4)	$\pm 0.4\%$	(For $\chi \geq 350$ kPa {3.5 kgf/cm ² })
	$\pm \left(0.1 + 0.3 \times \frac{350}{\chi}\right) \%$	(For $\chi < 350$ kPa {3.5 kgf/cm ² })
Ambient Temperature effect (Shift from the set range) Change of 30°C (*3) (Range from -5 to 55°C)	Combined shift: $\pm 2.28\%$	(For $\chi \geq 350$ kPa {3.5 kgf/cm ² })
	$\pm \left(0.76 + 1.52 \times \frac{350}{\chi}\right) \%$	(For $\chi < 350$ kPa {3.5 kgf/cm ² })

Model GTX60U (for regular type / high-temperature / oxygen / chlorine service)

Material of wetted parts: ASTM B575 (Hastelloy C-276 equivalent), Tantalum

Flange size: Flush diaphragm 3 inches (80 mm)

Reference accuracy (*3)(*4)	$\pm 0.2\%$	(For $\chi \geq 350$ kPa {3.5 kgf/cm ² })
	$\pm \left(0.05 + 0.15 \times \frac{350}{\chi}\right) \%$	(For $\chi < 350$ kPa {3.5 kgf/cm ² })
Ambient Temperature effect (Shift from the set range) Change of 30°C (*3) (Range from -5 to 55°C)	Combined shift: $\pm 0.9\%$	(For $\chi \geq 350$ kPa {3.5 kgf/cm ² })
	$\pm \left(0.35 + 0.55 \times \frac{350}{\chi}\right) \%$	(For $\chi < 350$ kPa {3.5 kgf/cm ² })

Model GTX60U (for regular type / high-temperature / oxygen / chlorine service)

Material of wetted parts: ASTM B575 (Hastelloy C-276 equivalent), Tantalum

Flange size: Flush diaphragm 2 inches (50 mm) 3/4 inches (20 mm), 1/2 inches (15 mm), 1.5 inch (40 mm)

Reference accuracy (*3)(*4)	$\pm 0.3\%$	(For $\chi \geq 350$ kPa {3.5 kgf/cm ² })
	$\pm \left(0.15 + 0.15 \times \frac{350}{\chi}\right) \%$	(For $\chi < 350$ kPa {3.5 kgf/cm ² })
Ambient Temperature effect (Shift from the set range) Change of 30°C (*3) (Range from -5 to 55°C)	Combined shift: $\pm 0.9\%$	(For $\chi \geq 350$ kPa {3.5 kgf/cm ² })
	$\pm \left(0.35 + 0.55 \times \frac{350}{\chi}\right) \%$	(For $\chi < 350$ kPa {3.5 kgf/cm ² })

Model GTX60U (for high temperature and vacuum / high temperature and high vacuum)

Material of wetted parts: ASTM B575 (Hastelloy C-276 equivalent), Tantalum

Flange Size: Flush diaphragm 3 inches (80 mm) Extended diaphragm 4 inches (100 mm)

Reference accuracy (*3)(*4)	$\pm 0.2\%$	(For $\chi \geq 350$ kPa {3.5 kgf/cm ² })
	$\pm \left(0.05 + 0.15 \times \frac{350}{\chi}\right) \%$	(For $\chi < 350$ kPa {3.5 kgf/cm ² })
Ambient Temperature effect (Shift from the set range) Change of 30°C (*3) (Range from -5 to 55°C)	Combined shift: $\pm 0.9\%$	(For $\chi \geq 350$ kPa {3.5 kgf/cm ² })
	$\pm \left(0.35 + 0.55 \times \frac{350}{\chi}\right) \%$	(For $\chi < 350$ kPa {3.5 kgf/cm ² })

Note) *3: Within a range of URV ≥ 0 and LRV ≥ 0 .

*4: Reference accuracy at calibrated condition.

Model GTX60U (for high temperature and vacuum / high temperature and high vacuum)

Material of wetted parts: ASTM B575 (Hastelloy C-276 equivalent), Tantalum

Flange Size: Flush diaphragm 2 inches (50 mm) / 1.5 inch (40 mm)

Reference accuracy (*3)(*4)		$\pm 0.3\%$	(For $\chi \geq 350$ kPa {3.5 kgf/cm ² })
		$\pm \left(0.3 \times \frac{350}{\chi}\right) \%$	(For $\chi < 350$ kPa {3.5 kgf/cm ² })
Ambient Temperature effect (Shift from the set range) Change of 30°C (*3) (Range from -5 to 55°C)	Combined shift:	$\pm 0.9\%$	(For $\chi \geq 350$ kPa {3.5 kgf/cm ² })
		$\pm \left(0.35 + 0.55 \times \frac{350}{\chi}\right)$	(For $\chi < 350$ kPa {3.5 kgf/cm ² })

Model GTX71U (for regular type / high-temperature service / oxygen service)

Material of wetted parts: 316 SST (Diaphragm; 316L SST), 316L SST

Flange size: Flush diaphragm 3 inches (80 mm) Extended diaphragm 4 inches (100 mm)

Reference accuracy (*3)(*4)		$\pm 0.2\%$	(For $\chi \geq 3.5$ MPa {35 kgf/cm ² })
		$\pm \left(0.05 + 0.15 \times \frac{3.5}{\chi}\right) \%$	(For $\chi < 3.5$ MPa {35 kgf/cm ² })
Ambient Temperature effect (Shift from the set range) Change of 30°C (*3) (Range from -5 to 55°C)	Combined shift:	$\pm 0.57\%$	(For $\chi \geq 3.5$ MPa {35 kgf/cm ² })
		$\pm \left(0.19 + 0.38 \times \frac{3.5}{\chi}\right) \%$	(For $\chi < 3.5$ MPa {35 kgf/cm ² })

Model GTX71U (for regular type / high-temperature / oxygen service)

Material of wetted parts: 316 SST (Diaphragm; 316L SST), 316L SST

Flange size: Flush diaphragm 2 inches (50 mm), Extended diaphragm 3 inches (80 mm), 2 inches wafer

Reference accuracy (*3)(*4)		$\pm 0.2\%$	(For $\chi \geq 3.5$ MPa {35 kgf/cm ² })
		$\pm \left(0.05 + 0.15 \times \frac{3.5}{\chi}\right)$	(For $\chi < 3.5$ MPa {35 kgf/cm ² })
Ambient Temperature effect (Shift from the set range) Change of 30°C (*3) (Range from -5 to 55°C)	Combined shift:	$\pm 0.57\%$	(For $\chi \geq 3.5$ MPa {35 kgf/cm ² })
		$\pm \left(0.19 + 0.38 \times \frac{3.5}{\chi}\right) \%$	(For $\chi < 3.5$ MPa {35 kgf/cm ² })

Model GTX71U (for regular type / high-temperature / oxygen service)

Material of wetted parts: 316 SST (Diaphragm; 316L SST), 316L SST

Flange size: Flush diaphragm 1.5 inch(40 mm), 3/4 inches (20 mm), 1/2 inches (15mm), Extended diaphragm 2 inches (50mm)

Reference accuracy (*3)(*4)		$\pm 0.4\%$	(For $\chi \geq 3.5$ MPa {35 kgf/cm ² })
		$\pm \left(0.25 + 0.15 \times \frac{3.5}{\chi}\right) \%$	(For $\chi < 3.5$ MPa {35 kgf/cm ² })
Ambient Temperature effect (Shift from the set range) Change of 30°C (*3) (Range from -5 to 55°C)	Combined shift:	$\pm 0.57\%$	(For $\chi \geq 3.5$ MPa {35 kgf/cm ² })
		$\pm \left(0.19 + 0.38 \times \frac{3.5}{\chi}\right) \%$	(For $\chi < 3.5$ MPa {35 kgf/cm ² })

Note) *3: Within a range of URV ≥ 0 and LRV ≥ 0 .

*4: Reference accuracy at calibrated condition.

Model GTX71U (for high temperature and vacuum / high temperature and high vacuum)

Material of wetted parts: 316 SST (Diaphragm; 316L SST), 316L SST

Flange Size: Flush diaphragm 3 inches (80 mm) Extended diaphragm 4 inches (100 mm)

Reference accuracy (*3)(*4)	$\pm 0.2\%$	(For $\chi \geq 3.5$ MPa {35 kgf/cm ² })
	$\pm \left(0.05 + 0.15 \times \frac{3.5}{\chi}\right) \%$	(For $\chi < 3.5$ MPa {35 kgf/cm ² })
Ambient Temperature effect (Shift from the set range) Change of 30°C (*3) (Range from -5 to 55°C)	Combined shift: $\pm 0.9\%$	(For $\chi \geq 3.5$ MPa {35 kgf/cm ² })
	$\pm \left(0.35 + 0.55 \times \frac{3.5}{\chi}\right) \%$	(For $\chi < 3.5$ MPa {35 kgf/cm ² })

Model GTX71U (for high temperature and vacuum / high temperature and high vacuum)

Material of wetted parts: 316 SST (Diaphragm; 316L SST), 316L SST

Flange Size: Flush diaphragm 2 inches (50 mm) / 1.5 inch (40 mm) Extended diaphragm 3 inches (80 mm) / 2 inches (50 mm), 2 inch water

Reference accuracy (*3)(*4)	$\pm 0.2\%$	(For $\chi \geq 3.5$ MPa {35 kgf/cm ² })
	$\pm \left(0.05 + 0.15 \times \frac{3.5}{\chi}\right) \%$	(For $\chi < 3.5$ MPa {35 kgf/cm ² })
Ambient Temperature effect (Shift from the set range) Change of 30°C (*3) (Range from -5 to 55°C)	Combined shift: $\pm 0.9\%$	(For $\chi \geq 3.5$ MPa {35 kgf/cm ² })
	$\pm \left(0.35 + 0.55 \times \frac{3.5}{\chi}\right) \%$	(For $\chi < 3.5$ MPa {35 kgf/cm ² })

Model GTX71U (for regular type / high-temperature / oxygen / chlorine service)
(For option "M5", 0.1mm thickness diaphragm)

Material of wetted parts: 316 SST (Diaphragm; 316L SST), 316L SST

Flange size: Flush diaphragm 3 inches (80 mm) Extended diaphragm 4 inches (100 mm)

Reference accuracy (*3)(*4)	$\pm 0.4\%$	(For $\chi \geq 3.5$ MPa {35 kgf/cm ² })
	$\pm \left(0.1 + 0.3 \times \frac{3.5}{\chi}\right) \%$	(For $\chi < 3.5$ MPa {35 kgf/cm ² })
Ambient Temperature effect (Shift from the set range) Change of 30°C (*3) (Range from -5 to 55°C)	Combined shift: $\pm 2.28\%$	(For $\chi \geq 3.5$ MPa {35 kgf/cm ² })
	$\pm \left(0.76 + 1.52 \times \frac{3.5}{\chi}\right) \%$	(For $\chi < 3.5$ MPa {35 kgf/cm ² })

Model GTX71U (for regular type / high-temperature / oxygen / chlorine service)

Material of wetted parts: ASTM B575 (Hastelloy C-276 equivalent), Tantalum

Flange size: Flush diaphragm 3 inches (80 mm)

Reference accuracy (*3)(*4)	$\pm 0.2\%$	(For $\chi \geq 3.5$ MPa {35 kgf/cm ² })
	$\pm \left(0.05 + 0.15 \times \frac{3.5}{\chi}\right) \%$	(For $\chi < 3.5$ MPa {35 kgf/cm ² })
Ambient Temperature effect (Shift from the set range) Change of 30°C (*3) (Range from -5 to 55°C)	Combined shift: $\pm 0.9\%$	(For $\chi \geq 3.5$ MPa {35 kgf/cm ² })
	$\pm \left(0.35 + 0.55 \times \frac{3.5}{\chi}\right) \%$	(For $\chi < 3.5$ MPa {35 kgf/cm ² })

Note) *3: Within a range of URV ≥ 0 and LRV ≥ 0 .

*4: Reference accuracy at calibrated condition.

Model GTX71U (for regular type and high-temperature / oxygen / chlorine service)

Material of wetted parts: ASTM B575 (Hastelloy C-276 equivalent), Tantalum

Flange size: Flush diaphragm 2 inches (50 mm) / 1.5 inch (40 mm), 3/4 inches (20 mm), 1/2 inches (15mm),

Reference accuracy (*3)(*4)		$\pm 0.4\%$	(For $\chi \geq 3.5$ MPa {35 kgf/cm ² })
		$\pm \left(0.25 + 0.15 \times \frac{3.5}{\chi}\right) \%$	(For $\chi < 3.5$ MPa {35 kgf/cm ² })
Ambient Temperature effect (Shift from the set range) Change of 30°C (*3) (Range from -5 to 55°C)	Combined shift:	$\pm 0.9\%$	(For $\chi \geq 3.5$ MPa {35 kgf/cm ² })
		$\pm \left(0.35 + 0.55 \times \frac{3.5}{\chi}\right) \%$	(For $\chi < 3.5$ MPa {35 kgf/cm ² })

Model GTX71U (for high temperature and vacuum / high temperature and high vacuum)

Material of wetted parts: ASTM B575 (Hastelloy C-276 equivalent), Tantalum

Flange Size: Flush diaphragm 3 inches (80 mm) Extended diaphragm 4 inches (100 mm)

Reference accuracy (*3)(*4)		$\pm 0.2\%$	(For $\chi \geq 3.5$ MPa {35 kgf/cm ² })
		$\pm \left(0.05 + 0.15 \times \frac{3.5}{\chi}\right) \%$	(For $\chi < 3.5$ MPa {35 kgf/cm ² })
Ambient Temperature effect (Shift from the set range) Change of 30°C (*3) (Range from -5 to 55°C)	Combined shift:	$\pm 0.9\%$	(For $\chi \geq 3.5$ MPa {35 kgf/cm ² })
		$\pm \left(0.35 + 0.55 \times \frac{3.5}{\chi}\right) \%$	(For $\chi < 3.5$ MPa {35 kgf/cm ² })

Model GTX71U (for high temperature and vacuum / high temperature and high vacuum)

Material of wetted parts: ASTM B575 (Hastelloy C-276 equivalent), Tantalum

Flange Size: Flush diaphragm 2 inches (50 mm) / 1.5 inch (40 mm)

Reference accuracy (*3)(*4)		$\pm 0.4\%$	(For $\chi \geq 3.5$ MPa {35 kgf/cm ² })
		$\pm \left(0.4 \times \frac{3.5}{\chi}\right) \%$	(For $\chi < 3.5$ MPa {35 kgf/cm ² })
Ambient Temperature effect (Shift from the set range) Change of 30°C (*3) (Range from -5 to 55°C)	Combined shift:	$\pm 0.9\%$	(For $\chi \geq 3.5$ MPa {35 kgf/cm ² })
		$\pm \left(0.35 + 0.55 \times \frac{3.5}{\chi}\right) \%$	(For $\chi < 3.5$ MPa {35 kgf/cm ² })

Model GTX82U (for regular type / high temperature / oxygen service)

Material of wetted parts: 316 SST (Diaphragm; 316L SST), 316L SST

Flange Size: G1½ External Screw, 2 inch water

Reference accuracy (*3)(*4)		$\pm 0.2\%$	(For $\chi \geq 7$ MPa {70 kgf/cm ² })
		$\pm \left(0.05 + 0.15 \times \frac{7}{\chi}\right) \%$	(For $\chi < 7$ MPa {70 kgf/cm ² })
Ambient Temperature effect (Shift from the set range) Change of 30°C (*3) (Range from -5 to 55°C)	Combined shift:	$\pm 0.57\%$	(For $\chi \geq 7$ MPa {70 kgf/cm ² })
		$\pm \left(0.19 + 0.38 \times \frac{7}{\chi}\right) \%$	(For $\chi < 7$ MPa {70 kgf/cm ² })

Note) *3: Within a range of URV ≥ 0 and LRV ≥ 0 .

*4: Reference accuracy at calibrated condition.

MODEL SELECTION

Model GTX35U (Remote-sealed type for standard gauge pressure)

Model GTX60U/GTX71U (Remote-sealed type for high gauge pressure)

Flush 3 inches flange type for regular/ high temperature/ oxygen/ chlorine service

Model No.:GTX_ _U-Selection I (I II III IV V VI VII VIII IX) - Selection II - Option

Basic Model No.

	Measuring span	2.5 to 100kPa (250 to 10,160mmH ₂ O)	GTX35U	Flush flange type 3 inches (80mm)
		35 to 3500kPa (0.35 to 35kgf/cm ²)	GTX60U	
		0.7 to 10MPa (7 to 102kgf/cm ²)	GTX71U	

Selection I

I	Output	4 to 20mA (SFN Communication)	A	
		4 to 20mA (HART Communication)	B	
		Digital output (DE communication) *3	D	
II	Fill fluid	Regular type (Silicone oil)	A	
		For high temperature service (Silicone oil)	B	
		For oxygen service (Fluorine oil)	H	
		For chlorine service (Fluorine oil) *2	J	
III	Wetted parts material	316 SST (Diaphragm:316L SST)	A	
		ASTM B575 (Equivalent to Hastelloy C-276)	B	
		Tantalum *1	C	
		316L SST	D	
IV	Flange rating	ANSI150	A1	
		ANSI300	A2	
		ANSI600	A3	
		JIS10K	J1	
		JIS20K	J3	
		JIS30K	J4	
		JIS63K	J6	
		JPI150	P1	
		JPI300	P2	
		JPI600	P3	
V	Flange size	3in./80A	F	
VI	Flange type	Flash type	A	
VII	Flange material/ bolt and nut material	Flange	Bolt and nut	
		304 SST	304 SST	A
		304 SST	630 SST	C
		304 SST	Carbon steel	D
		316 SST	304 SST	E
		316 SST	630 SST	G
		316 SST	Carbon steel	H
		316L SST	304 SST	J
		316L SST	630 SST	L
316L SST	Carbon steel	M		
VIII	Gasket face finish	None Standard JISRa3.2(12.5S)	A	
IX	Capillary length	2m	02	
		3m	03	
		4m	04	
		5m	05	
		6m	06	
		7m	07	
		8m	08	
		9m	09	
		10m	10	
		2m (with Olefin Cover)	A2	
		3m (with Olefin Cover)	A3	
		4m (with Olefin Cover)	A4	
		5m (with Olefin Cover)	A5	
		6m (with Olefin Cover)	A6	
		7m (with Olefin Cover)	A7	
		8m (with Olefin Cover)	A8	
		9m (with Olefin Cover)	A9	
10m (with Olefin Cover)	A0			

Note) *1 In case "Tantalum" is used for diaphragm material and in case of "For high-temperature service", normal operating temperature of wetted parts is -10 to +180deg.C.

*2 In case code J is selected, code C "Tantalum" of Wetted parts material should be selected.

*3 Not applicable for the combination with code A2 "With external Zero/Span adjustment", Q1 "Safety Transmitter" and Q2 "NAMUR NE43 Compliant Output Signal Limits" of Option.

Model GTX35U(Remote-sealed type for standard gauge pressure)
Model GTX60U/GTX71U(Remote-sealed type for high gauge pressure)
Extended 4 inches flange type for regular/ high temperature/ oxygen/ chlorine service
 Model No.:GTX__U-Selection I (I II III IV V VI VII VIII IX) Selection II - Option

Basic Model No.

	Measuring span	2.5 to 100kPa (250 to 10,160mmH2O)	GTX35U	Extended flange type 4 inches (100mm)
		35 to 3500kPa (0.35 to 35kgf/cm ²)	GTX60U	
		0.7 to 10MPa (7 to 102kgf/cm ²)	GTX71U	

Selection I

I	Output	4 to 20mA (SFN Communication)	A	
		4 to 20mA (HART Communication)	B	
		Digital output (DE communication) *2	D	
II	Fill fluid	Regular type (Silicone oil) *4	A	
		For high temperature service (Silicone oil) *1 *3	B	
		For oxygen service (Fluorine oil) *4	H	
III	Wetted parts material	316 SST (Diaphragm:316L SST)	A	
		316L SST *1 *3 *4	D	
IV	Flange rating	ANSI150	A1	
		ANSI300 *1	A2	
		JIS10K	J1	
		JIS20K	J3	
		JIS30K *3 *4	J4	
		JPI150	P1	
		JPI300*1	P2	
V	Flange size	4in./100A	G	
VI	Flange type	Extended Length 50mm	B	
		Extended Length 100mm	C	
		Extended Length 150mm *4	D	
		Extended Length 200mm *4	E	
		Extended Length 250mm *1 *4	F	
		Extended Length 300mm *1 *4	G	
VII	Flange material/ bolt and nut material	Flange	Bolt and nut	
		304 SST	304 SST	A
		304 SST	630 SST	C
		304 SST	Carbon steel	D
		316 SST	304 SST	E
		316 SST	630 SST	G
		316 SST	Carbon steel	H
		316L SST	304 SST	J
		316L SST	630 SST	L
316L SST	Carbon steel	M		
VIII	Gasket face finish	None Standard JISRa3.2(12.5S)	A	
IX	Capillary length	2m	02	
		3m	03	
		4m	04	
		5m	05	
		6m	06	
		7m	07	
		8m	08	
		9m	09	
		10m	10	
		2m (with Olefin Cover)	A2	
		3m (with Olefin Cover)	A3	
		4m (with Olefin Cover)	A4	
		5m (with Olefin Cover)	A5	
		6m (with Olefin Cover)	A6	
		7m (with Olefin Cover)	A7	
		8m (with Olefin Cover)	A8	
		9m (with Olefin Cover)	A9	
10m (with Olefin Cover)	A0			

Note) *1 In case Fill Fluid: For high-temperature service and Flange rating: ANSI300 and wetted parts material: 316L SST, Extension length of Flange 250/300mm are not available.
 *2 Not applicable for the combination with code A2 "With external Zero/Span adjustment", Q1 "Safety Transmitter" and Q2 "NAMUR NE43 Compliant Output Signal Limits" of Option.
 *3 In case Fill Fluid: For high-temperature service, not applicable for the combination with wetted parts material "316L SST" and Flange Type "JIS 30K".
 *4 In case Fill Fluid: Regular type or For oxygen service and Flange rating: JIS30K and wetted parts material:316L SST, Extended length of Flange 150/200/250/300mm are not available.

Model GTX60U/GTX71U(Remote-sealed type for high gauge pressure)
Flush 2 inches, 1.5inches flange type for regular/ high temperature/ oxygen/ chlorine service
 Model No.:GTX_ _U-Selection I (I II III IV V VI VII VIII IX) - Selection II -Option

Basic Model No.

	Measuring span	35 to 3500kPa (0.35 to 35kgf/cm ²)	GTX60U	Flush flange type 2 inches (50mm), 1.5 inches(40mm)
		0.7 to 10MPa (7 to 102kgf/cm ²)	GTX71U	

Selection I

I	Output	4 to 20mA (SFN Communication)	A	
		4 to 20mA (HART Communication)	B	
		Digital output (DE communication) *3	D	
II	Fill fluid	Regular type (Silicone oil)	A	
		For high temperature service (Silicone oil)	B	
		For oxygen service (Fluorine oil)	H	
		For chlorine service (Fluorine oil) *2	J	
III	Wetted parts material	316 SST (Diaphragm:316L SST)	A	
		ASTM B575 (Equivalent to Hastelloy C-276)	B	
		Tantalum *1	C	
		316L SST	D	
IV	Flange rating	ANSI150	A1	
		ANSI300	A2	
		ANSI600	A3	
		JIS10K	J1	
		JIS20K	J3	
		JIS30K	J4	
		JIS63K	J6	
		JPI150	P1	
		JPI300	P2	
		JPI600	P3	
V	Flange size	1.5in./40A	D	
		2in./50A	E	
VI	Flange type	Flash type	A	
VII	Flange material/ bolt and nut material	Flange	Bolt and nut	
		304 SST	304 SST	A
		304 SST	630 SST	C
		304 SST	Carbon steel	D
		316 SST	304 SST	E
		316 SST	630 SST	G
		316 SST	Carbon steel	H
		316L SST	304 SST	J
		316L SST	630 SST	L
316L SST	Carbon steel	M		
VIII	Gasket face finish	None Standard JISRa3.2(12.5S)	A	
IX	Capillary length	2m	02	
		3m	03	
		4m	04	
		5m	05	
		2m (with Olefin Cover)	A2	
		3m (with Olefin Cover)	A3	
		4m (with Olefin Cover)	A4	
		5m (with Olefin Cover)	A5	

Note) *1 In case "Tantalum" is used for diaphragm material and in case of "For high-temperature service", normal operating temperature of wetted parts is -10 to +180deg.C.

*2 In case code J is selected, code C "Tantalum" of Wetted parts material should be selected.

*3 Not applicable for the combination with code A2 "With external Zero/Span adjustment", Q1 "Safety Transmitter" and Q2 "NAMUR NE43 Compliant Output Signal Limits" of Option.

Model GTX60U/GTX71U(Remote-sealed type for high gauge pressure)

Extended 3 inches, 2 inches flange type for regular/ high temperature/ oxygen/ chlorine service

Model No.:GTX__U-Selection I(I II III IV V VI VII VIII IX) - Selection II -Option II

Basic Model No.

	Measuring span	35 to 3500kPa (0.35 to 35kgf/cm ²)	GTX60U	Extended flange type 3 inches (80mm), 2 inches(50mm)
		0.7 to 10MPa (7 to 102kgf/cm ²)	GTX71U	

Selection I

I	Output	4 to 20mA (SFN Communication)	A	
		4 to 20mA (HART Communication)	B	
		Digital output (DE communication) *3	D	
II	Fill fluid	Regular type (Silicone oil)	A	
		For high temperature service (Silicone oil) *2	B	
		For oxygen service (Fluorine oil)	H	
III	Wetted parts material	316 SST (Diaphragm:316L SST)	A	
		316L SST *2	D	
IV	Flange rating	ANSI150	A1	
		ANSI300	A2	
		ANSI600 *1 *2	A3	
		JIS10K	J1	
		JIS20K	J3	
		JIS30K	J4	
		JPI150	P1	
		JPI300	P2	
V	Flange size	2in./50A *2	E	
		3in./80A *1	F	
VI	Flange type	Extended Length 50mm *1	B	
		Extended Length 100mm *1	C	
		Extended Length 150mm *1	D	
		Extended Length 200mm *1 *2	E	
		Extended Length 250mm *1 *2	F	
		Extended Length 300mm *1 *2	G	
VII	Flange material/ bolt and nut material	Flange	Bolt and nut	
		304 SST	304 SST	A
		304 SST	630 SST	C
		304 SST	Carbon steel	D
		316 SST	304 SST	E
		316 SST	630 SST	G
		316 SST	Carbon steel	H
		316L SST	304 SST	J
		316L SST	630 SST	L
316L SST	Carbon steel	M		
VIII	Gasket face finish	None Standard JISRa3.2(12.5S)	A	
IX	Capillary length	2m	02	
		3m	03	
		4m	04	
		5m	05	
		2m (with Olefin Cover)	A2	
		3m (with Olefin Cover)	A3	
		4m (with Olefin Cover)	A4	
		5m (with Olefin Cover)	A5	

- Note) *1 In case of "ANSI/JPI600" is used for 3in. Flange type and rating, not available for the extended diaphragm flange type.
 *2 In case Fill Fluid: For high-temperature service: ANSI/JPI600 and Wetted Parts material: SUS316L, Extension length of Flange 200/250/300mm are not available.
 *3 Not applicable for the combination with code A2 "With external Zero/Span adjustment", Q1 "Safety Transmitter" and Q2 "NAMUR NE43 Compliant Output Signal Limits" of Option.

Model GTX60U/GTX71U(Remote-sealed type for high gauge pressure)**Flush 3 inches flange type for high temperature vacuum, high temperature high vacuum service**

Model No.: GTX__U-Selection I(I II III IV V VI VII VIII IX) - Selection II -Option

Basic Model No.

	Measuring span	35 to 3500kPa (0.35 to 35kgf/cm ²)	GTX60U	Flush flange type 3 inches (80mm)
		0.7 to 10MPa (7 to 102kgf/cm ²)	GTX71U	

Selection I

I	Output	4 to 20mA (SFN Communication)	A	
		4 to 20mA (HART Communication)	B	
		Digital output (DE communication) *2	D	
II	Fill fluid	For high temperature vacuum service (Silicone oil)	C	
		For high temperature high vacuum service (Silicone oil)	D	
III	Wetted parts material	ASTM B575 (Equivalent to Hastelloy C-276)	B	
		Tantalum *1	C	
		316L SST	D	
IV	Flange rating	ANSI150	A1	
		ANSI300	A2	
		ANSI600	A3	
		JIS10K	J1	
		JIS20K	J3	
		JIS30K	J4	
		JIS63K	J6	
		JPI150	P1	
		JPI300	P2	
		JPI600	P3	
V	Flange size	3in./80A	F	
VI	Flange type	Flush type	A	
VII	Flange material/ bolt and nut material	Flange	Bolt and nut	
		304 SST	304 SST	A
		304 SST	630 SST	C
		304 SST	Carbon steel	D
		316 SST	304 SST	E
		316 SST	630 SST	G
		316 SST	Carbon steel	H
		316L SST	304 SST	J
		316L SST	630 SST	L
316L SST	Carbon steel	M		
VIII	Gasket face finish	None Standard JISRa3.2(12.5S)	A	
IX	Capillary length	2m	02	
		3m	03	
		4m	04	
		5m	05	
		6m	06	
		7m	07	
		8m	08	
		9m	09	
		10m	10	

Note) *1 In case "Tantalum" is used for diaphragm material, normal operating temperature of wetted parts is -10 to +180deg.C.

*2 Not applicable for the combination with code A2 "With external Zero/Span adjustment", Q1 "Safety Transmitter" and Q2 "NAMUR NE43 Compliant Output Signal Limits" of Option.

Model GTX60U/GTX71U(Remote-sealed type for high gauge pressure)

Extended 4 inches flange type for high temperature vacuum, high temperature high vacuum service

Model No.:GTX__U-Selection I(I II III IV V VI VII VIII IX)- Selection II -Option

Basic Model No.

	Measuring span	35 to 3500kPa (0.35 to 35kgf/cm ²)	GTX60U	Extended flange type 4 inches (100mm)
		0.7 to 10MPa (7 to 102kgf/cm ²)	GTX71U	

Selection I

I	Output	4 to 20mA (SFN Communication)	A	
		4 to 20mA (HART Communication)	B	
		Digital output (DE communication) *2	D	
II	Fill fluid	For high temperature vacuum service (Silicone oil)	C	
		For high temperature high vacuum service (Silicone oil)	D	
III	Wetted parts material	316 SST (Diaphragm:316L SST)	A	
		316L SST *1*3	D	
IV	Flange rating	ANSI150	A1	
		ANSI300 *1	A2	
		JIS10K	J1	
		JIS20K	J3	
		JIS30K *3	J4	
		JPI150	P1	
		JPI300 *1	P2	
V	Flange size	4in./80A	F	
VI	Flange type	Extended Length 50mm	B	
		Extended Length 100mm	C	
		Extended Length 150mm	D	
		Extended Length 200mm *1	E	
		Extended Length 250mm *1	F	
		Extended Length 300mm *1	G	
VII	Flange material/ bolt and nut material	Flange	Bolt and nut	
		304 SST	304 SST	A
		304 SST	630 SST	C
		304 SST	Carbon steel	D
		316 SST	304 SST	E
		316 SST	630 SST	G
		316 SST	Carbon steel	H
		316L SST	304 SST	J
		316L SST	630 SST	L
316L SST	Carbon steel	M		
VIII	Gasket face finish	None Standard JISRa3.2(12.5S)	A	
IX	Capillary length	2m	02	
		3m	03	
		4m	04	
		5m	05	
		6m	06	
		7m	07	
		8m	08	
		9m	09	
		10m	10	

Note) *1 In case "ANSI/JPI300" is used for Flange Type & Rating, and "316L SST" is used for wetted parts material, not available for Length of Extended Parts: 200/250/300mm.

*2 Not applicable for the combination with code A2 "With external Zero/Span adjustment", Q1 "Safety Transmitter" and Q2 "NAMUR NE43 Compliant Output Signal Limits" of Option.

*3 Not applicable for the combination with wetted parts material "316L SST" and Flange Type "JIS30K".

Model GTX60U/GTX71U(Remote-sealed type for high gauge pressure)

Flash 2 inches,1.5 inches flange type for high temperature vacuum, high temperature high vacuum service

Model No.:GTX__U-Selection I(I II III IV V VI VII VIII IX) - Selection II -Option

Basic Model No.

	Measuring span	35 to 3500kPa (0.35 to 35kgf/cm ²)	GTX60U	Flush flange type 2 inches (50mm), 1.5 inches(40mm)
		0.7 to 10MPa (7 to 102kgf/cm ²)	GTX71U	

Selection I

I	Output	4 to 20mA (SFN Communication)	A	
		4 to 20mA (HART Communication)	B	
		Digital output (DE communication) *2	D	
II	Fill fluid	For high temperature vacuum service (Silicone oil)	C	
		For high temperature high vacuum service (Silicone oil)	D	
III	Wetted parts material	ASTM B575 (Equivalent to Hastelloy C-276)	B	
		Tantalum *1	C	
		316L SST	D	
IV	Flange rating	ANSI150	A1	
		ANSI300	A2	
		ANSI600	A3	
		JIS10K	J1	
		JIS20K	J3	
		JIS30K	J4	
		JIS63K	J6	
		JPI150	P1	
		JPI300	P2	
		JPI600	P3	
V	Flange size	1.5in./40A	D	
		2in./50A	E	
VI	Flange type	Flush type	A	
VII	Flange material/ bolt and nut material	Flange	Bolt and nut	
		304 SST	304 SST	A
		304 SST	630 SST	C
		304 SST	Carbon steel	D
		316 SST	304 SST	E
		316 SST	630 SST	G
		316 SST	Carbon steel	H
		316L SST	304 SST	J
		316L SST	630 SST	L
316L SST	Carbon steel	M		
VIII	Gasket face finish	None Standard JISRa3.2(12.5S)	A	
IX	Capillary length	2m	02	
		3m	03	
		4m	04	
		5m	05	

Note) *1 In case "Tantalum" is used for diaphragm material, normal operating temperature of wetted parts is -10 to +180deg.C.

Note) *2 Not applicable for the combination with code A2 "With external Zero/Span adjustment", Q1 "Safety Transmitter" and Q2 "NAMUR NE43 Compliant Output Signal Limits" of Option.

Model GTX60U/GTX71U(Remote-sealed type for high gauge pressure)

Extended 3 inches, 2 inches flange type for high temperature vacuum, high temperature high vacuum service

Model No.:GTX__U-Selection I(I II III IV V VI VII VIII IX) - Selection II -Option

Basic Model No.

	Measuring span	35 to 3500kPa(0.35 to 35kgf/cm ²)	GTX60U	Extended flange type 3 inches (80mm), 2 inches(50mm)
		0.7 to 10MPa (7 to 102kgf/cm ²)	GTX71U	

Selection I

I	Output	4 to 20mA (SFN Communication)	A	
		4 to 20mA (HART Communication)	B	
		Digital output (DE communication) *3	D	
II	Fill fluid	For high temperature vacuum service (Silicone oil)	C	
		For high temperature high vacuum service (Silicone oil)	D	
III	Wetted parts material	316 SST (Diaphragm:316L SST)	A	
		ASTM B575 (Equivalent to Hastelloy C-276)	B	
		Tantalum	C	
		316L SST *2	D	
IV	Flange rating	ANSI150	A1	
		ANSI300	A2	
		ANSI600 *1 *2	A3	
		JIS10K	J1	
		JIS20K	J3	
		JIS30K	J4	
		JPI150	P1	
		JPI300	P2	
		JPI600 *1 *2	P3	
V	Flange size	2in./50A *2	E	
		3in./80A *1	F	
VI	Flange type	Extended Length 50mm	B	
		Extended Length 100mm	C	
		Extended Length 150mm	D	
		Extended Length 200mm *2	E	
		Extended Length 250mm *2	F	
		Extended Length 350mm *2	G	
VII	Flange material/ bolt and nut material	Flange	Bolt and nut	
		304 SST	304 SST	A
		304 SST	630 SST	C
		304 SST	Carbon steel	D
		316 SST	304 SST	E
		316 SST	630 SST	G
		316 SST	Carbon steel	H
		316L SST	304 SST	J
		316L SST	630 SST	L
316L SST	Carbon steel	M		
VIII	Gasket face finish	None Standard JISRa3.2(12.5S)	A	
IX	Capillary length	2m	02	
		3m	03	
		4m	04	
		5m	05	

- Note) *1 In case of "ANSI/JPI600" is used for 3in. Flange type and rating, not available for the extended diaphragm flange type.
 *2 ANSI/JPI600 and Wetted Parts material: SUS316L, Extension length of Flange 200/250/300mm are not available.
 *3 Not applicable for the combination with code A2 "With external Zero/Span adjustment", Q1 "Safety Transmitter" and Q2 "NAMUR NE43 Compliant Output Signal Limits" of Option.

Model GTX71U(Remote-sealed type for high gauge pressure)
Model GTX82U(Remote-sealed type for highest gauge pressure)
G1-1/2 inches Button diaphragm (Male) for regular/ oxygen

Model No.:GTX__U-Selection I(I II III IV V VI VII VIII IX) - Selection II -Option

Basic Model No.

	Measuring span	0.7 to 10MPa (7 to 102kgf/cm ²)	GTX71U	G1-1/2 inches Button diaphragm (Male)
		0.7 to 42MPa (7 to 420kgf/cm ²)	GTX82U	

Selection I

I	Output	4 to 20mA (SFN Communication)	A	
		4 to 20mA (HART Communication)	B	
		Digital output (DE communication) *2	D	
II	Fill fluid	Regular type (Silicone oil)	A	
		For oxygen service (Fluorine oil)	H	
III	Wetted parts material	316 SST (Diaphragm:316L SST)	A	
		316L SST	D	
IV	Flange rating	No flange		XX
V	Flange size	G1-1/2"Button diaphragm Male		H
VI	Flange type	Flush type		A
VII	Flange material/ bolt and nut material	Flange	Bolt and nut	
		No flange *1	304 SST *1	1
		No flange	630 SST	3
		No flange	Carbon steel	4
VIII	Gasket face finish	None Standard JISRa3.2(12.5S)		A
IX	Capillary length	2m		02
		3m		03
		4m		04
		5m		05
		2m (with Olefin Cover)		A2
		3m (with Olefin Cover)		A3
		4m (with Olefin Cover)		A4
5m (with Olefin Cover)		A5		

Note) *1 Not applicable for GTX82U.

*2 Not applicable for the combination with code A2 "With external Zero/Span adjustment", Q1 "Safety Transmitter" and Q2 "NAMUR NE43 Compliant Output Signal Limits" of Option.

Model GTX60U/GTX71U(Remote-sealed type for high gauge pressure)
Model GTX82U(Remote-sealed type for highest gauge pressure)
2 inches wafer type for regular/ high temperature/ oxygen service
 Model No.:GTX__U-Selection I(I II III IV V VI VII VIII IX) - Selection II -Option

Basic Model No.

	Measuring span	35 to 3500kPa (0.35 to 35kgf/cm ²)	GTX60U	2 inches wafer type
		0.7 to 10MPa (7 to 102kgf/cm ²)	GTX71U	
		0.7 to 42MPa (7 to 420kgf/cm ²)	GTX82U	

Selection I

I	Output	4 to 20mA (SFN Communication)	A	
		4 to 20mA (HART Communication)	B	
		Digital output (DE communication) *1	D	
II	Fill fluid	Regular type (Silicone oil)	A	
		For oxygen service (Fluorine oil)	H	
III	Wetted parts material	316 SST (Diaphragm:316L SST)	A	
		316L SST	D	
IV	Flange rating	No flange	XX	
V	Flange size	2in. wafer type	J	
VI	Flange type	Flush type	A	
VII	Flange material/ bolt and nut material	Flange	Bolt and nut	
		No flange	630 SST	3
		No flange	Carbon steel	4
VIII	Gasket face finish	None Standard JISRa3.2(12.5S)	A	
IX	Capillary length	2m		02
		3m		03
		4m		04
		5m		05
		6m		06
		7m		07
		8m		08
		9m		09
		10m		10
		2m (with Olefin Cover)		A2
		3m (with Olefin Cover)		A3
		4m (with Olefin Cover)		A4
		5m (with Olefin Cover)		A5
		6m (with Olefin Cover)		A6
		7m (with Olefin Cover)		A7
		8m (with Olefin Cover)		A8
		9m (with Olefin Cover)		A9
10m (with Olefin Cover)		A0		

Note) *1 Not applicable for the combination with code A2 "With external Zero/Span adjustment", Q1 "Safety Transmitter" and Q2 "NAMUR NE43 Compliant Output Signal Limits" of Option.

**Model GTX60U/GTX71U(Remote-sealed type for high gauge pressure)
2 inches wafer type for high temperature vacuum, high temperature high vacuum service**

Model No.:GTX_ _U-Selection I(I II III IV V VI VII VIII IX)- Selection II -Option

Basic Model No.

	Measuring span	35 to 3500kPa (0.35 to 35kgf/cm ²)	GTX60U	2 inches wafer type
		0.7 to 10MPa (7 to 102kgf/cm ²)	GTX71U	

Selection I

I	Output	4 to 20mA (SFN Communication)		A
		4 to 20mA (HART Communication)		B
		Digital output (DE communication) *1		D
II	Fill fluid	For high temperature vacuum service (Silicone oil)		C
		For high temperature high vacuum service (Silicone oil)		D
III	Wetted parts material	316L SST		D
IV	Flange rating	No flange		XX
V	Flange size	2in. wafer type		J
VI	Flange type	Flush type		A
VII	Flange material/ bolt and nut material	Flange	Bolt and nut	
		No flange	630 SST	3
		No flange	Carbon steel	4
VIII	Gasket face finish	None Standard JISRa3.2(12.5S)		A
IX	Capillary length	2m		02
		3m		03
		4m		04
		5m		05
		6m		06
		7m		07
		8m		08
		9m		09
		10m		10

Note) *1 Not applicable for the combination with code A2 "With external Zero/Span adjustment", Q1 "Safety Transmitter" and Q2 "NAMUR NE43 Compliant Output Signal Limits" of Option.

Model GTX60U(Remote-sealed type for high gauge pressure)
Model GTX71U(Remote-sealed type for high gauge pressure)
Flush 3/4 inches, 1/2inches flange type for regular/ high temperature/ oxygen/ chlorine service)
 Model No.:GTX__U-Selection I(I II III IV V VI VII VIII IX) - Selection II -Option

Basic Model No.

	Measuring span	35 to 3500kPa (0.35 to 35kgf/cm ²)	GTX60U	Flush flange type 3/4 inches (20mm), 1/2 inches(15mm)
		0.7 to 10MPa (7 to 102kgf/cm ²)	GTX71U	

Selection I

I	Output	4 to 20mA (SFN Communication)	A	
		4 to 20mA (HART Communication)	B	
		Digital output (DE communication) *2	D	
II	Fill fluid	Regular type (Silicone oil)	A	
		For high temperature service (Silicone oil)	B	
		For oxygen service (Fluorine oil)	H	
III	Wetted parts material	316 SST (Diaphragm:316L SST)	A	
		ASTM B575 (Equivalent to Hastelloy C-276)	B	
		316L SST	D	
IV	Flange rating	No flange	XX	
V	Flange size	For small size flange model	X	
VI	Flange type	For small flange type adapter assembled, rear connection to capillary *1	1	
		For small flange type with no adapter, rear connection to capillary	3	
VII	Flange material/ bolt and nut material	Flange	Bolt and nut	
		No flange	304 SST	1
		No flange	630 SST	3
		No flange	Carbon steel	4
VIII	Gasket face finish	None Standard JISRa3.2(12.5S)	A	
IX	Capillary length	2m		02
		3m		03
		4m		04
		5m		05
		2m (with Olefin Cover)		A2
		3m (with Olefin Cover)		A3
		4m (with Olefin Cover)		A4
		5m (with Olefin Cover)		A5

Note) *1 Small flange mounting kit model (HF-) should be selected.

*2 Not applicable for the combination with code A2 "With external Zero/Span adjustment", Q1 "Safety Transmitter" and Q2 "NAMUR NE43 Compliant Output Signal Limits" of Option.

Model No.:GTX__U-Selection I(I II III IV V VI VII VIII IX)-Selection II (I II III IV V VI) - Option

Selection II		-		
I	Electric connection	1/2 NPT, Watertight	A	
		M20, Watertight *18	B	
II	Explosion proof	None		XX
		FM Explosion proof		F1
		FM Intrinsically safe		F2
		FM Nonincendive		F5
		Combined of FM Explosion proof, Intrinsically safe and Nonincendive		F6
		ATEX Explosion proof		A1
		ATEX Intrinsically safe		A2
		ATEX Type n		A5
		IECEX Explosion proof,		E1
		IECEX Intrinsically safe		E2
		IECEX Type n		E5
		NEPSI Explosionproof		N1
		NEPSI Intrinsically safe		N2
NEPSI Type n		N5		
III	Indicator	None	X	
		With indicator	A	
IV	Paint	Standard	X	
		Corrosion-proof (Urethane)	H	
		Corrosion-resistant (Silver color)	D	
V	Failure alarm	UP Scale		A
		DOWN scale		B
VI	Mounting Bracket	None		X
		Carbon steel (Flat Form)		5
		304 SST (Flat Form)		6
Options				-
		No options		XX
		External Zero span adjustment *11 *19		A2
		Long vent/drain plugs		G4
		Oil and water free finish		K1
		Oil free finish *4		K3
		Au Plating Diaphragm *17		L1
		0.1mm thickness diaphragm *12 *13		M5
		FEP protective film *14 *15 *16		N1
		Safety Transmitter *5 *19		Q1
		NAMUR NE43 Compliant Output signal limits:3.8 to 20.5mA (Output 21.6mA/selected upper limit, 3.6mA/selected lower limit) *19		Q2
		Alarm Output (contact output) *20		Q7
		Custom calibration		R1
		Test report		T1
		Mill certificate		T2
		Traceability certificate		T4
		NACE certificate *9		T5
		Non SI Unit		W1

- Note) *4 Not need to select when Fill Fluid code H, or J is selected.
 *5 Not applicable for the combination with code A2, or Q7 of Option.
 *9 Applicable for "ASTM B575", code B of Material (center body).
 *11 Not applicable for the combination with code X "None" of Indicator. Please select "With indicator".
 *12 1 mm thickness diaphragm option is only available for Material of Wetted parts: "316 SST" and "316L SST".
 *13 0.1 mm thickness diaphragm option is only available for 4inches Extended Flange or 3inches Flush Flange.
 *14 Not applicable for the combination with Extended Flange Type.
 *15 Not applicable for the combination with code B, C, and D of Fill Fluid. (Max. 110 degree C)
 *16 Not applicable for the combination with 1/2 inches or 3/4 inches flange.
 *17 Not applicable for the combination with "Tantalum" of diaphragm Material.
 *18 Not applicable for the combination with code F1, F6 of Explosion proof.
 *19 Not applicable for the combination with code D "Digital output (DE communication)" of output.
 *20 Not applicable for the combination with code F2, F5, F6, N2, N5, E2, E5, A2 and A5 of Explosion proof.

Small flange type mounting kit
(Adapter flange)

HF -

I	II	III	IV	V
---	----	-----	----	---

 -

VI

I	Adapter flange quantity	For GP remote (1 PIECE)	H					
II	Flange size	1/2in.		1				
		3/4in.		2				
		JIS10K		A				
		JIS20K		C				
		JIS30K		D				
III	Flange rating	ANSI150		G				
		ANSI300		H				
		JPI150		N				
		JPI300		P				
IV	Adapter material	SCS14A or 316 SST			2			
V	Bolt/nut material	630 SST				3		
							-	
VI	Option	None					X	
		Oil and water finish *1					1	
		Oil free finish *1						2
		Long Vent / Drain Plug						3
		Assembled with a transmitter						4

Note) *1 When this option is selected, the same option for transmitter must be selected.

DIMENSION

Model GTX35U/60U/71U

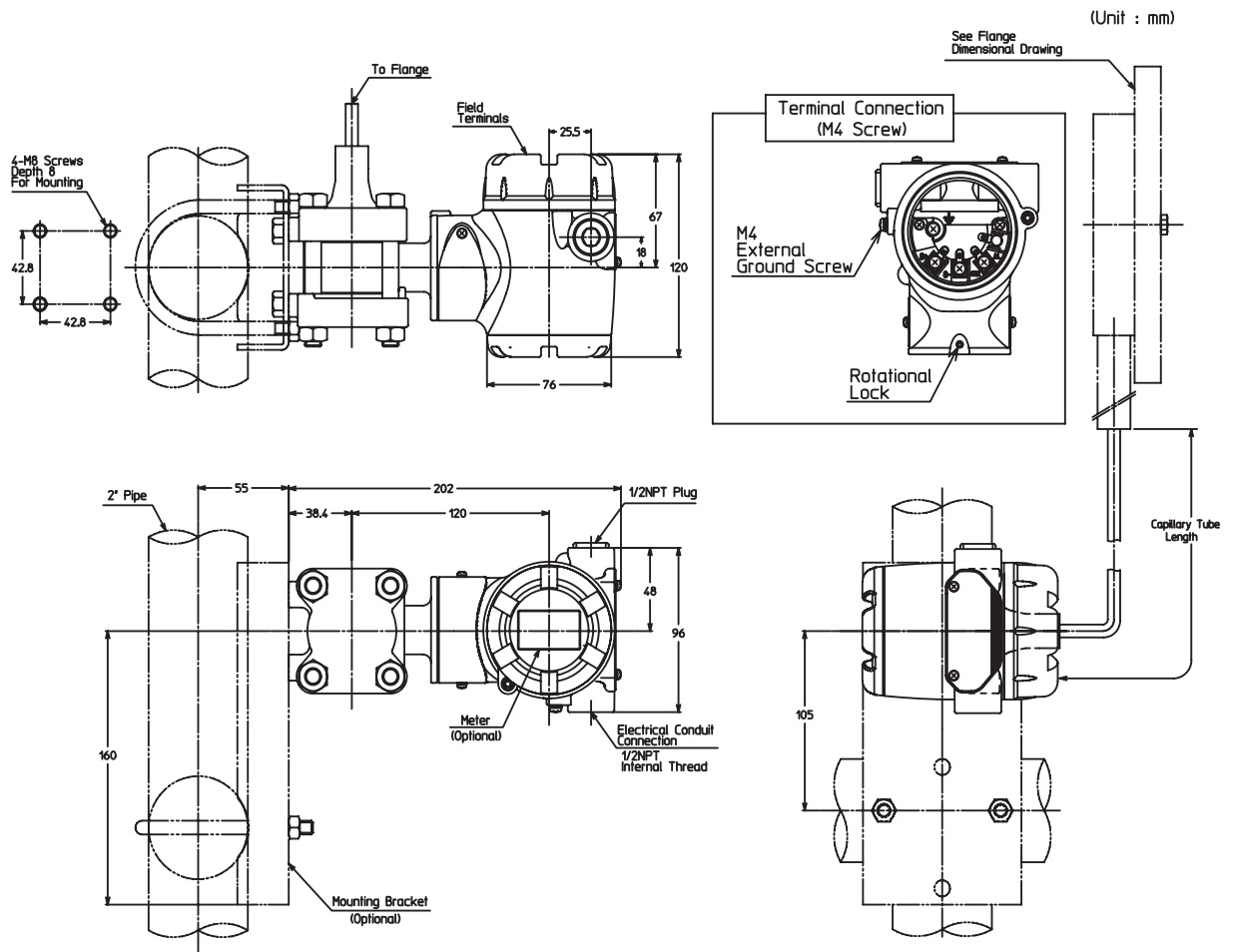

Model GTX82U

(Unit : mm)

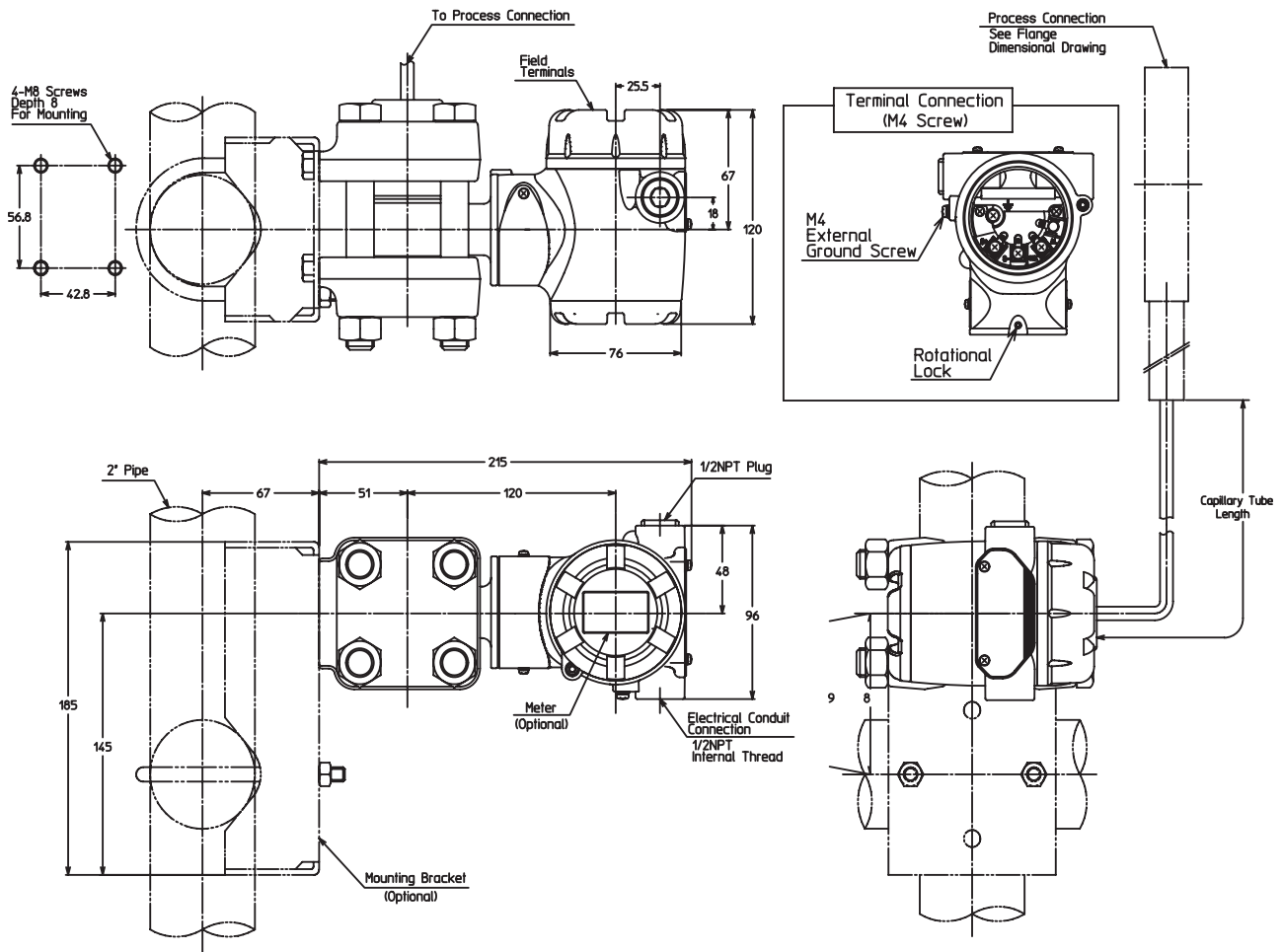

Table of flash diaphragm flange dimensions

Rating	Flange rating	D	T	C	N	H	d	t	B
1.5 inch (40 mm)	JIS 10K - 40 mm	140	16	105	4	19	81	25* ⁱ	43
	JIS 20K - 40 mm	140	18	105	4	19			
	JIS 30K - 40 mm	160	22	120	4	23			
	ANSI 150 - 1.5 inch	127	18	98.6	4	16			
	ANSI 300 - 1.5 inch	155	21	114.3	4	22			
	ANSI 600 - 1.5 inch	155	22.5	114.3	4	22			
	JPI 150 - 1.5 inch	127	18	98.6	4	16			
	JPI 300 - 1.5 inch	155	21	114.3	4	22			
2 inches (50 mm)	JIS 10K - 50 mm	155	16	120	4	19	99	62* ⁱⁱ	
	JIS 20K - 50 mm	155	18	120	8	19			
	JIS 30K - 50 mm	165	22	130	8	19			
	ANSI 150 - 2 inches	152	19.5	120.6	4	19			
	ANSI 300 - 2 inches	165	22.5	127	8	19			
	ANSI 600 - 2 inches	165	25.5	127	8	19			
	JPI 150 - 2 inches	152	19.5	120.6	4	19			
	JPI 300 - 2 inches	165	22.5	127	8	19			
3 inches (80 mm)	JIS 10K - 80 mm	185	18	150	8	19	129.5	25	95
	JIS 20K - 80 mm	200	22	160	8	23			
	JIS 30K - 80 mm	210	28	170	8	23			
	ANSI 150 - 3 inches	190	24	152.4	4	19			
	ANSI 300 - 3 inches	210	28.5	168.1	8	22			
	ANSI 600 - 3 inches	210	32	168.1	8	22			
	JPI 150 - 3 inches	190	24	152.4	4	19			
	JPI 300 - 3 inches	210	28.5	168.1	8	22			

- i. Wetted parts material is ASTMB575 and fill fluid is for regular, high-temperature, oxygen, or chlorine service: t = 26.7
- ii. Wetted parts material is ASTMB575 and fill fluid is for regular, high-temperature, oxygen, or chlorine service: B = 43

Table of extended diaphragm flange dimensions

Rating	Flange rating	D	T	C	N	H	d	A	t	B	L
2 inches (50 mm)	JIS 10K - 50 mm	155	16	120	4	19	99	47±1	25	43	50
	JIS 20K - 50 mm	155	18	120	8	19					100
	JIS 30K - 50 mm	165	22	130	8	19					150
	ANSI 150 - 2 inches	152	19.5	120.6	4	19					200
	ANSI 300 - 2 inches	165	22.5	127	8	19					250
	ANSI 600 - 2 inches	165	25.5	127	8	19					300
	JPI 150 - 2 inches	152	19.5	120.6	4	19					
	JPI 300 - 2 inches	165	22.5	127	8	19					
3 inches (80 mm)	JIS 10K - 80 mm	185	18	150	8	19	129.5	69±1	25	62	
	JIS 20K - 80 mm	200	22	160	8	23					
	JIS 30K - 80 mm	210	28	170	8	23					
	ANSI 150 - 3 inches	190	24	152.4	4	19					
	ANSI 300 - 3 inches	210	28.5	168.1	8	22					
	ANSI 600 - 3 inches	210	32	168.1	8	22					
	JPI 150 - 3 inches	190	24	152.4	4	19					
	JPI 300 - 3 inches	210	28.5	168.1	8	22					
4 inches (100 mm)	JIS 10K - 100 mm	210	18	175	8	19	157	95±1	23	90.4	
	JIS 20K - 100 mm	225	24	185	8	23					
	JIS 30K - 100 mm	240	32	195	8	25					
	ANSI 150 - 4 inches	229	24	190.5	8	19					
	ANSI 300 - 4 inches	254	32	200.2	8	22					
	JPI 150 - 4 inches	229	24	190.5	8	19					
JPI 300 - 4 inches	254	32	200.2	8	22						

2-inch wafer Bottom diaphragm

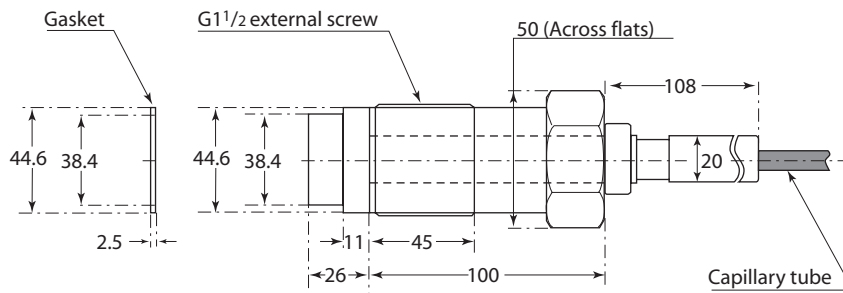
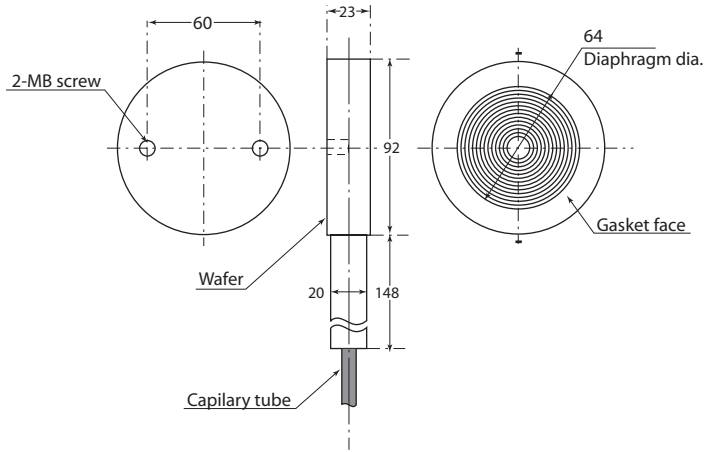

Model GTX60U/71U

[Unit: mm]

1/2 or 3/4 inch flange adapter assembly drawing Table of flange dimensions

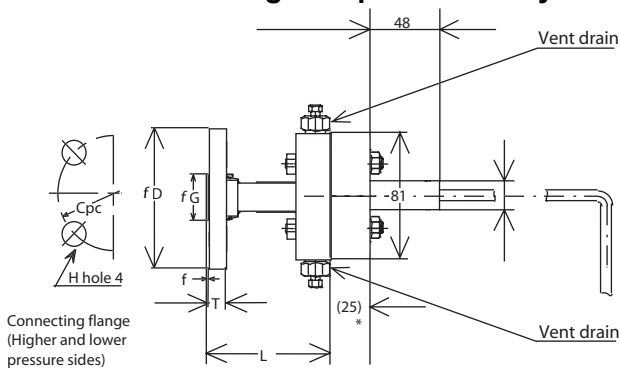

Flange standard	ϕD	ϕG	T	f	ϕC	ϕH	ϕL
JIS 10K - 15 mm (1/2 inch)	95	51	12	1	70	15	84
JIS 20K - 15 mm (1/2 inch)	95	51	14	1	70	15	84
JIS 30K - 15 mm (1/2 inch)	115	55	18	1	80	19	79
ANSI 150 - 15 mm (1/2 inch)	89	35.1	11.5	1.6	60.5	16	86
ANSI 300 - 15 mm (1/2 inch)	95	35.1	14.5	1.6	66.5	16	92
JPI 150 - 15 mm (1/2 inch)	89	35.1	11.5	1.6	60.5	16	86
JPI 300 - 15 mm (1/2 inch)	95	35.1	14.5	1.6	66.5	16	92
JIS 10K - 20 mm (3/4 inch)	100	56	14	1	75	15	90
JIS 20K - 20 mm (3/4 inch)	100	56	16	1	75	15	90
JIS 30K - 20 mm (3/4 inch)	120	60	18	1	85	19	84
ANSI 150 - 20 mm (3/4 inch)	99	42.9	13	1.6	69.8	16	90
ANSI 300 - 20 mm (3/4 inch)	117	42.9	16	1.6	82.6	19	99
JPI 150 - 20 mm (3/4 inch)	99	42.9	13	1.6	69.8	16	90
JPI 300 - 20 mm (3/4 inch)	117	42.9	16	1.6	82.6	19	99

Note) *: In the case of tantalum for wetted part material, this is 24 mm.

Specifications are subject to change without notice.

azbil

Yamatake Corporation
Advanced Automation Company

1-12-2 Kawana, Fujisawa-shi
Kanagawa-ken 251-8522 Japan

URL: <http://www.azbil.com>

No part of this publication may be reproduced or duplicated without the prior written permission of Yamatake Corporation.

May 2008-Y/Y
Mar. 2011 (rev.12)-Y/Y