

AT9000 Advanced Transmitter

Remote-sealed type of Absolute Pressure Transmitters

OVERVIEW

AT9000 Advanced Transmitter is a microprocessor-based smart transmitter that features high performance and excellent stability. Capable of measuring gas, liquid, and vapor, and liquid levels, it transmits 4 to 20 mA DC analog and digital signals according to the measured pressure. It can also execute two-way communications between the CommPad (Handy Communicator) or HART[®] 375 communicator, thus facilitating self-diagnosis, range resetting, and automatic zero adjustment.



FEATURES

Excellent stability and high performance

- Long-term stability is proven in 500,000 installations worldwide.
- Unique characterization and composite semiconductor sensors realize excellent temperature and static pressure characteristics.

Remote communication

- Two-way communication using digital output facilitates self-diagnosis, range resetting, automatic zero adjustment, and other operations.
- HART[®] protocol communication is available. (Option)

China RoHS

This device is used in the Oil & Gas, Petrochemical, Chemical, Pulp & Paper, Food & Beverage, Machinery, Steel/Metal & Mining, and Automobile industries and therefore does not fall under the China RoHS Legislation.

If this device is used in semiconductor manufacturing equipment, labeling on the device and documents for the China RoHS may be required. If such documents are required, consult a Yamatake representative.

HART[®] is a registered trademark of the HART Communication Foundation.

APPLICATION**Petroleum / Petrochemical / Chemical**

For the measurement of liquid levels including corrosive fluids at high temperatures, and high temperatures under vacuum

Electric power / City gas / Other utilities

For measurement applications that require high degrees of stability and accuracy.

Pulp and paper

For lines that need transmitters resistant to chemical liquids, corrosive fluids and the like.

Iron and steel / Nonferrous metal / Ceramics

For lines that require stable measurement under strictly controlled (temperature, humidity, etc.) conditions.

Machinery / Shipbuilding

For lines that require stable measurement under strictly controlled (temperature, humidity, vibration, etc.) conditions.

FUNCTIONAL SPECIFICATIONS**Type of protection**

NEMA3 and 4X
IEC IP67

FM Explosionproof and Dust Approvals

Explosionproof for Class I, Division 1, Groups A, B, C and D; Class I, Zone 1, AEx d IIC
Dust-Ignitionproof for Class II, III, Division 1, Groups E, F and G

T5 $-40^{\circ}\text{C} \leq T_{\text{amb}} \leq +85^{\circ}\text{C}$

Hazardous locations

Indoor / Outdoor Type 4X, IP67

Factory sealed, conduit seal not required for Division applications

Caution - Use supply wires suitable for 5°C above surrounding ambient



FM Intrinsically safe Approval

IS/I,II,III/1/ABCDEFGH/T4; $-40^{\circ}\text{C} \leq T_{\text{amb}} \leq +60^{\circ}\text{C}$;
80395278, 80395279, 80395280; Entity; TYPE 4X; IP67
I/O/ AEx ia/IIC/T4; $-40^{\circ}\text{C} \leq T_{\text{amb}} \leq +60^{\circ}\text{C}$; 80395278,
80395279, 80395280; Entity; TYPE 4X; IP67
Entity Parameters: $V_{\text{max}}(U_i)=30$ Volts, $I_{\text{max}}(I_i)=100\text{mA}$,
 $P_i=1\text{W}$, $C_i=10\text{nF}$, $L_i=0.5\text{mH}$

FM Nonincendive Approval

NI/I/2/ABCD/T4; $-40^{\circ}\text{C} \leq T_{\text{amb}} \leq +60^{\circ}\text{C}$; 80395494;
NIFW; TYPE 4X; IP67
NI/I/2/IIC/T4; $-40^{\circ}\text{C} \leq T_{\text{amb}} \leq +60^{\circ}\text{C}$; 80395494;
NIFW; TYPE 4X; IP67
S/II,III/1/EFG/T4; $-40^{\circ}\text{C} \leq T_{\text{amb}} \leq +60^{\circ}\text{C}$;
80395494; NIFW; TYPE 4X; P67
Nonincendive Field Wiring Parameters: $V_{\text{max}}(U_i)=30$
Volts, $C_i=10\text{nF}$, $L_i=0.5\text{mH}$

ATEX Flameproof and Dust Certifications

 0344  KEMA 08ATEX0004

II 1/2 G Ex d IIC T6 $T_{\text{process}}=85^{\circ}\text{C}$

$-30^{\circ}\text{C} \leq T_{\text{amb}} \leq +75^{\circ}\text{C}$ IP66/67

II 1/2 G Ex d IIC T5 $T_{\text{process}}=100^{\circ}\text{C}$

$-30^{\circ}\text{C} \leq T_{\text{amb}} \leq +80^{\circ}\text{C}$ IP66/67

II 1/2 G Ex d IIC T4 $T_{\text{process}}=110^{\circ}\text{C}$

$-30^{\circ}\text{C} \leq T_{\text{amb}} \leq +80^{\circ}\text{C}$ IP66/67

II 2 D Ex tD A21 IP66/67 T85 $T_{\text{process}}=85^{\circ}\text{C}$

$-30^{\circ}\text{C} \leq T_{\text{amb}} \leq +75^{\circ}\text{C}$

II 2 D Ex tD A21 IP66/67 T100 $T_{\text{process}}=100^{\circ}\text{C}$

$-30^{\circ}\text{C} \leq T_{\text{amb}} \leq +75^{\circ}\text{C}$

II 2 D Ex tD A21 IP66/67 T110 $T_{\text{process}}=110^{\circ}\text{C}$

$-30^{\circ}\text{C} \leq T_{\text{amb}} \leq +75^{\circ}\text{C}$

Caution - Use supply wires suitable for 5°C above surrounding ambient

ATEX Intrinsic safety and Dust Certifications

 0344  KEMA 07ATEX0200 X

II 1 G Ex ia IIC T4 $T_{\text{PROCESS}} = 105^{\circ}\text{C}$

$-30^{\circ}\text{C} \leq T_{\text{amb}} \leq +60^{\circ}\text{C}$ IP66 / 67

ELECTRICAL PARAMETERS: $U_i = 30$ V, $I_i = 93$ mA,
 $P_i = 1$ W, $C_i = 5$ nF, $L_i = 0.5$ mH

II 1 D Ex iaD 20 IP66 / 67 T105 $T_{\text{PROCESS}} = 105^{\circ}\text{C}$

$-30^{\circ}\text{C} \leq T_{\text{amb}} \leq +60^{\circ}\text{C}$

ATEX Type n and Dust Certifications

 0344  KEMA 07ATEX0200 X

II 3 G Ex nL IIC T4 $T_{\text{PROCESS}} = 105^{\circ}\text{C}$

$-30^{\circ}\text{C} \leq T_{\text{amb}} \leq +60^{\circ}\text{C}$ IP66 / 67

ELECTRICAL PARAMETERS: $U_i = 30$ V, $C_i = 5$ nF, $L_i = 0.5$ mH

II 2 D Ex tD A21 IP66 / 67 T85 $T_{\text{PROCESS}} = 85^{\circ}\text{C}$

$-30^{\circ}\text{C} \leq T_{\text{amb}} \leq +75^{\circ}\text{C}$

II 2 D Ex tD A21 IP66 / 67 T100 $T_{\text{PROCESS}} = 100^{\circ}\text{C}$

$-30^{\circ}\text{C} \leq T_{\text{amb}} \leq +80^{\circ}\text{C}$

II 2 D Ex tD A21 IP66 / 67 T110 $T_{\text{PROCESS}} = 110^{\circ}\text{C}$

$-30^{\circ}\text{C} \leq T_{\text{amb}} \leq +80^{\circ}\text{C}$

NEPSI Flameproof and Dust Certifications

Ex d IIC T6 DIP A21 T_A 85°C $T_{\text{process}}=80^{\circ}\text{C}$ $-40^{\circ}\text{C} \leq T_{\text{amb}} \leq +75^{\circ}\text{C}$

Ex d IIC T5 DIP A21 T_A 100°C $T_{\text{process}}=95^{\circ}\text{C}$ $-40^{\circ}\text{C} \leq T_{\text{amb}} \leq +80^{\circ}\text{C}$

Ex d IIC T4 DIP A21 T_A 115°C $T_{\text{process}}=110^{\circ}\text{C}$ $-40^{\circ}\text{C} \leq T_{\text{amb}} \leq +80^{\circ}\text{C}$

ENCLOSURE TYPE IP66/67

Certificate No. GYJ071268

NEPSI Intrinsic Safety Certification

Ex ia IIC T4 $T_{\text{process}}=105^{\circ}\text{C}$ $-40^{\circ}\text{C} \leq T_{\text{amb}} \leq +60^{\circ}\text{C}$
Enclosure IP66 / 67

Electrical Parameters: $U_i=30\text{V}$, $I_i=100\text{mA}$, $P_i=1\text{W}$,
 $C_i=13\text{nF}$, $L_i=0.5\text{mH}$

Certificate No. GYJ071269

NEPSI Type n Certification

Ex nL IIC T4 $T_{\text{process}}=110^{\circ}\text{C}$ $-40^{\circ}\text{C} \leq T_{\text{amb}} \leq +60^{\circ}\text{C}$
Enclosure IP66 / 67

Electrical Parameters: $U_i=30\text{V}$, $I_i=100\text{mA}$, $P_i=1\text{W}$,
 $C_i=13\text{nF}$, $L_i=0.5\text{mH}$

Certificate No. GYJ071269

IECEX Flameproof and Dust Certifications

Certificate No. IECEx KEM 08.0001
 Ga/Gb Ex d IIC T6 Tprocess=85°C -30°C ≤ Tamb ≤ +75°C IP66/67
 Ga/Gb Ex d IIC T5 Tprocess=100°C -30°C ≤ Tamb ≤ +80°C IP66/67
 Ga/Gb Ex d IIC T4 Tprocess=110°C -30°C ≤ Tamb ≤ +80°C IP66/67
 Ex tD A21 IP66/67 T85 Tprocess=85°C -30°C ≤ Tamb ≤ +75°C
 Ex tD A21 IP66/67 T100 Tprocess=100°C -30°C ≤ Tamb ≤ +75°C
 Ex tD A21 IP66/67 T110 Tprocess=110°C -30°C ≤ Tamb ≤ +75°C
 Caution - Use supply wires suitable for 5°C above surrounding ambient

IECEX Intrinsic safety and Dust Certifications

IECEX KEM 07.0058X
 Zone 0 Ex ia IIC T4 TPROCESS = 105 °C
 -30 °C ≤ Tamb ≤ +60 °C IP66 / 67
 ELECTRICAL PARAMETERS: Ui = 30 V, Ii = 93 mA, Pi = 1 W, Ci = 5 nF, Li = 0.5 mH
 Ex iaD 20 IP66 / 67 T105 TPROCESS = 105 °C
 -30 °C ≤ Tamb ≤ +60 °C

IECEX Type n and Dust Certifications

IECEX KEM 07.0058X
 Ex nL IIC T4 TPROCESS = 105 °C
 -30 °C ≤ Tamb ≤ +60 °C IP66 / 67
 ELECTRICAL PARAMETERS: Ui = 30 V, Ci = 5 nF, Li = 0.5 mH
 Ex tD A21 IP66 / 67 T85 TPROCESS = 85 °C
 -30 °C ≤ Tamb ≤ +75 °C
 Ex tD A21 IP66 / 67 T100 TPROCESS = 100 °C
 -30 °C ≤ Tamb ≤ +80 °C
 Ex tD A21 IP66 / 67 T110 TPROCESS = 110 °C
 -30 °C ≤ Tamb ≤ +80 °C

EMC Conformity

89/336/EEC, 92/31/EEC, 93/68/EEC Electromagnetic Compatibility (EMC) Directive

Measuring span / Setting range / Working pressure range

	Measuring span	Setting range	Working pressure range	Overload resistant value
GTX 30S	4 to 104 kPa abs. {30 to 780 mmHg abs.}	0 to 104 kPa abs. {0 to 780 mmHg abs.}	0.13 to 104 kPa abs.	300 kPa abs. {3.0 kgf/cm ² }
GTX 60S	35 to 3500 kPa abs. {0.35 to 35 kgf/cm ² abs.}	0 to 3500 kPa abs. {0 to 35 kgf/cm ² abs.}	Up to flange rating of the setting range, which is lower.	5250 kPa abs. {52.5 kgf/cm ² }

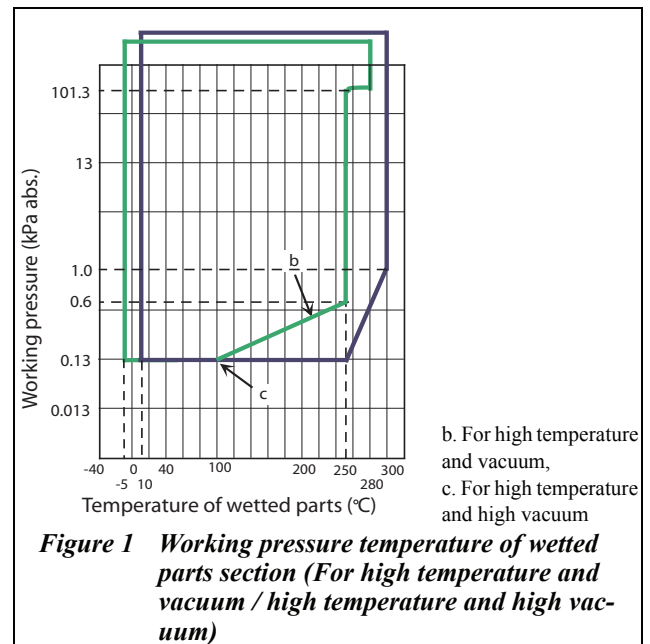

Supply voltage and load resistance

17.9 to 42V DC. A load resistance of 250 Ω or more is necessary between loops. See Figure 2.

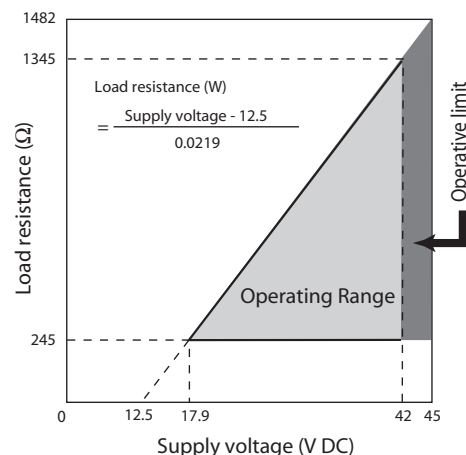

Figure 2 Supply voltage vs. load resistance characteristics

Note) For communication with HART communicator, a load resistance of 250 Ω or more is necessary.

Output

Analog output (4 to 20 mA DC) with DE protocol
 Analog output (4 to 20 mA DC) with HART protocol
 Digital output (DE protocol)

Output signal

3.6 to 21.6 mA
 3.8 to 20.5 mA (NAMUR NE43 compliant)

Failure Alarm

Upper: 21.6 mA or more
 Lower: 3.6 mA or less

Ambient temperature limits / Temperature ranges of wetted parts

		Temperature Range (°C) *1 *4	
		High-temp. vacuum models	High-temp. high-vacuum models
Wetted parts section	Normal operating range	-5 to 280	10 to 300
	Operative limit range	-10 to 310	-10 to 310
Ambient temperature *2	Normal operating range	-5 to 55	10 to 55
	Operative limit range	-10 to 60	-10 to 60
Specific gravity of fill fluid *3		1.07	1.09

- Note *1. See the working pressures and temperatures of the wetted parts section in Figure 1.
 *2. Ambient temperatures of the transmitter itself
 *3. Approximate values at the temperature of 25°C
 *4. Note that if the operating temperature falls below the lower limit of the normal operating range, the response of the transmitter becomes slower.

Ambient humidity limits

5 to 100% RH

Stability against supply voltage change

± 0.005% FS/V

Dead time

Max. 0.4 sec.

Damping time

Selectable from 0 to 32 sec. in ten stages

Lightning protection

Applicable Standards; IEC 61000-4-5

Peak value of current surge(80/20μ sec.): 6000A

Indicator

The digital LCD indicator (optional) indicates engineering units and can be set freely between -99999 and 99999 (5 digits). For meter calibration, specify the following items when placing your order

- Meter calibration range
 - Meter calibration unit
 - Linear / Square-root for meter indication.
- Various kinds of data can be set using the CommPad or the HART®375 communicator.

Bolts and nuts materials (for fastening meter body cover)

Carbon steel (SNB7), 304 SST, 630 SST

Paint

Standard

Corrosion-resistant paint (Baked acrylic paint)

Corrosion-proof finish

Corrosion-proof paint (Baked urethane paint), fungus-proof finish

Corrosion-resistant finish (silver color)

Transmitter case is coated with silver paint in addition to the above corrosion-resistant finish.

OPTIONAL SPECIFICATIONS**Oil free finish**

The transmitter is shipped with oil-free wetted parts.

External zero/span adjustment function

The transmitter can be easily zero/span adjusted in the field.

Elbow

This is an adaptor for changing the electrical conduit connection port from the horizontal to the vertical direction, if required by wiring conditions in the field. One or two elbows may be used as needed.

Conformance to SI units

We deliver transmitters set to any SI units as specified.

Safety Transmitter

Select this option to be used as a component of Safety Instrumented System (SIS).

AT9000 is complied with IEC61508, certified according to Safety Integrity Level2 (SIL-2)

Alarm Output (contact output)

Contact output is prepared as alarm output when alarm (Output Alarm/Sensor Temp. Alarm) condition is detected. It can be set to Normally Open. (When alarm is detected, Contact ON).

Custom calibration

Calibrate for the specified pressure range at the factory.

PHYSICAL SPECIFICATIONS**Materials****Fill fluid**

Silicone oil for high-temperature vacuum, and high temperature high-vacuum models

For specific gravity, refer to “Ambient temperature limits / Temperature ranges of wetted parts” on page 4

Center body

316 SST

Transmitter case

Aluminum alloy

Meter body cover

304 SST

For Wetted parts

316 SST (316L SST for diaphragm only)

316L SST

Flange materials

304 SST, 316 SST, 316L SST

Weight

Approx. 13.5 kg (GTX30S)

(Including ANSI 150# - 3 inches flange and capillary 5 m long)

INSTALLATION**Electrical connection**

1/2NPT internal thread, M20 internal thread.

Grounding

Resistance 100 Ω max.

Mounting

Direct mounting on the process side

Using 2-inch pipe mounting brackets: Mount the transmitter on a horizontal or vertical 2-inch pipe

Bracket

Carbon steel, 304 SST

U-bolt and nuts

304 SST

Process connection**Measured pressure**

Flanges

Flush diaphragm

JIS 10K, 20K, 30K and 63K: 80mm(RF) equivalents

ANSI/JPI 150,300 and 600:3 inches (RF) equivalents

Extended diaphragm

JIS 10K, 20K and 30K: 100mm(RF) equivalents

ANSI/JPI 150 and 300: 4 inches (RF) equivalents

Flange standards

JIS; JIS B 2220 (2004)

ANSI; ANSI B 16.5 (1988)

JPI; JPI-7S-15-93

Mounting notes**For pressure measurement**

- 1) If the fluid to be measured contains hydrogen, please consult us.
- 2) When mounting the transmitter, leave a space of at least 10 cm under the upper nozzle of the tank. If the no space is available, please consult us.

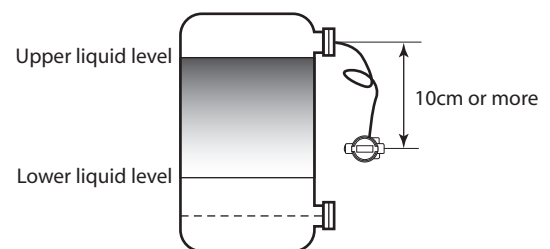
**⚠ WARNING**

- Impact to transmitter can damage sensor module.

PERFORMANCE SPECIFICATIONS

Max working pressure

- Note) 1. Max working pressure depends on flange rating, flange materials and operating temperature. Please refer to the following data. Operating range of temperature depends on specification of transmitters.
2. In case of flange type (model GTX60F) and remote scaled type (model GTX□□□□, model GTX60U), max working pressure depends on the smaller value of either 1.5 MPa or following data.
3. In case of remote scaled type (model GTX71U), max working pressure depends on the smaller value of either 10 MPa or following data.

	JIS	JPI/ANSI
304 SST		
316 SST		
316L SST		

Reference accuracy

Shown for each item are the percentage ratio for χ (kPa), which is the greatest value of either the upper range value (URV)^{*1}, the lower range value (LRV)^{*2} or the span.

Model GTX30S (for high-temperature vacuum, high-temperature high-vacuum service)

Reference accuracy (*1)		$\pm 0.25\%$	(For $\chi \geq 12$ kPa abs. (90 mmHg abs.))
		$\pm (0.1 + 0.15 \times \frac{12}{\chi})\%$	(For $\chi < 12$ kPa abs. (90 mmHg abs.))
Ambient Temperature effect (Shift from the set range) Change of 30°C (Range from -5 to 55°C)	Combined shift	$\pm 0.79\%$	(For $\chi \geq 12$ kPa abs. (90 mmHg abs.))
		$\pm (0.19 + 0.6 \times \frac{12}{\chi})\%$	(For $\chi < 12$ kPa abs. (90 mmHg abs.))

Model GTX60S (for high-temperature vacuum, high-temperature high-vacuum service)

Reference accuracy (*1)		$\pm 0.25\%$	(For $\chi \geq 350$ kPa abs. (3.5 kgf/cm ² abs.))
		$\pm (0.1 + 0.15 \times \frac{350}{\chi})\%$	(For $\chi < 350$ kPa abs. (3.5 kgf/cm ² abs.))
Ambient Temperature effect (Shift from the set range) Change of 30°C (Range from -5 to 55°C)	Combined shift	$\pm 0.79\%$	(For $\chi \geq 350$ kPa abs. (3.5 kgf/cm ² abs.))
		$\pm (0.19 + 0.6 \times \frac{350}{\chi})\%$	(For $\chi < 350$ kPa abs. (3.5 kgf/cm ² abs.))

Note) *1: Reference accuracy at calibrated condition.

MODEL SELECTION

Model GTX30S (Remote-sealed type for standard absolute pressure)

Model GTX60S (Remote-sealed type for high absolute pressure)

Flush 3 inches flange type for high temperature vacuum, high temperature high vacuum service

Model No.: GTX_ _U-Selection I (I II III IV V VI VII) - Selection II (I II III IV V VI) - Option

Basic Model No.

	Measuring span	4.0 to 104 kPa abs. (30 to 780mmHg abs.)	GTX30S	Flush flange type 3 inches (80mm)
		35 to 3500 kPa abs.(0.35 to 35kgf/cm ² abs.)	GTX60S	

Selection I

I	Output	4 to 20mA (SFN Communication)	A	
		4 to 20mA (HART Communication)	B	
		Digital output (DE communication) *4	D	
II	Fill fluid	For high temperature vacuum service (Silicone oil)	C	
		For high temperature high vacuum service (Silicone oil)	D	
III	Wetted parts material	316L SST	D	
IV	Flange rating	ANSI150	A1	
		ANSI300	A2	
		ANSI600	A3	
		JIS10K	J1	
		JIS20K	J3	
		JIS30K	J4	
		JIS63K	J6	
		JPI150	P1	
		JPI300	P2	
	JPI600	P3		
V	Flange size	3in./80A	F	
VI	Flange type	Flash type	A	
VII	Flange material/bolt and nut material	Flange	Bolt and nut	
		304 SST	304 SST	A
		304 SST	630 SST	C
		304 SST	Carbon steel	D
		316 SST	304 SST	E
		316 SST	630 SST	G
		316 SST	Carbon steel	H
		316L SST	304 SST	J
		316L SST	630 SST	L
	316L SST	Carbon steel	M	
VIII	Gasket face finish	None Standard JISRa3.2(12.5S)	A	
IX	Capillary length	2m	02	
		3m	03	
		4m	04	
		5m	05	
		6m	06	
		7m	07	
		8m	08	
		9m	09	
		10m	10	

Selection II

I	Electrical connection	1/2 NPT, Watertight	A
		M20, Watertight *3	B
II	Explosion proof	None	XX
		FM Explosion proof	F1
		FM Intrinsically safe	F2
		FM Nonincendive	F5
		ATEX Explosion proof	A1
		ATEX Intrinsically safe	A2
		ATEX Type n	A5
		IECEX Explosion proof,	E1
		IECEX Intrinsically safe	E2
		IECEX Type n	E5
		NEPSI Explosionproof	N1
NEPSI Intrinsically safe	N2		
	NEPSI Type n	N5	
III	Built-in indicating smart meter	None	X
		With indicator	A
IV	Paint	Standard	X
		Corrosion-resistant (Urethane)	H
		Corrosion-resistant (Silver color)	D
V	Burnout feature	UP Scale	A
		DOWN scale	B
VI	Mounting Bracket	None	X
		Carbon steel (Flat Form)	5
		304 SST (Flat form)	6

Note) *1 Specify range in abs. Pressure. Correct: 0 to 500mmHg abs. Incorrect: -700mmHg to 1kgf/cm².

*2 Specify range in abs. Pressure. Correct: 0 to 3kgf/cm² abs. Incorrect: -1 to 2kgf/cm² abs.

*3 Not applicable for the combination with code F1, F6 of Explosion proof.

*4 Not applicable for the combination with code A2 "With external Zero/Span adjustment", Q1 "Safety Transmitter", and Q2 "NAMUR NE43 Compliant Output signal limits" of Option.

Model GTX30S (Remote-sealed type for standard absolute pressure)

Model GTX60S (Remote-sealed type for high absolute pressure)

Extended 4 inches flange type for high temperature vacuum, high temperature high vacuum service

Model No.:GTX__U-Selection I (I II III IV V VI VII) - Selection II (I II III IV V VI) - Option

Basic Model No.

	Measuring span	4.0 to 104 kPa abs. (30 to 780mmHg abs.) *1	GTX30S	Extended flange type 4 inches (100mm)
		35 to 3500 kPa abs. (0.35 to 35kgf/cm ² abs.) *2	GTX60S	

Selection I

I	Output	4 to 20mA (SFN Communication)	A		
		4 to 20mA (HART Communication)	B		
		Digital output (DE communication) *5	D		
II	Fill fluid	For high temperature vacuum service (Silicone oil)	C		
		For high temperature high vacuum service (Silicone oil)	D		
III	Wetted parts material	316 SST (Diaphragm:316L SST)	A		
		316L SST	D		
IV	Flange rating	ANSI150	A1		
		ANSI300	A2		
		JIS10K	J1		
		JIS20K	J3		
		JIS30K	J4		
		JPI150	P1		
		JPI300 *3	P2		
V	Flange size	4in./100A	G		
VI	Flange type	Extended Length 50mm	B		
		Extended Length 100mm	C		
		Extended Length 150mm	D		
		Extended Length 200mm *3	E		
		Extended Length 250mm *3	F		
		Extended Length 300mm *3	G		
VII	Flange material/bolt and nut material	Flange	Bolt and nut		
		304 SST	304 SST		A
		304 SST	630 SST		C
		304 SST	Carbon steel		D
		316 SST	304 SST		E
		316 SST	630 SST		G
		316 SST	Carbon steel		H
		316L SST	304 SST		J
		316L SST	630 SST		L
316L SST	Carbon steel	M			
VIII	Gasket face finish	None Standard JISRa3.2(12.5S)	A		
IX	Capillary length	2m	02		
		3m	03		
		4m	04		
		5m	05		
		6m	06		
		7m	07		
		8m	08		
		9m	09		
		10m	10		

Selection II

I	Electrical connection	1/2 NPT, Watertight	A	
		M20, Watertight *4	B	
II	Explosion proof	None		XX
		FM Explosion proof		F1
		FM Intrinsically safe		F2
		FM Nonincendive		F5
		ATEX Explosion proof		A1
		ATEX Intrinsically safe		A2
		ATEX Type n		A5
		IECEX Explosion proof		E1
		IECEX Intrinsically safe		E2
		IECEX Type n		E5
		NEPSI Explosionproof		N1
		NEPSI Intrinsically safe		N2
NEPSI Type n		N5		
III	Built-in indicating smart meter	None		X
		With indicator	A	
IV	Paint	Standard		X
		Corrosion-proof (Urethane)		H
		Corrosion-resistant (Silver color)		D
V	Failure alarm	UP Scale	A	
		DOWN scale	B	
VI	Mounting Bracket	None		X
		Carbon steel (Flat Form)		5
		304 SST (Flat form)		6

Note) *1 Specify range in abs. Pressure. Correct: 0 to 500mmHg abs. Incorrect: -700mmHg to 1kgf/cm².
 *2 Specify range in abs. Pressure. Correct: 0 to 3kgf/cm² abs. Incorrect: -1 to 2kgf/cm² abs.
 *3 In case "ANSI/JPI300" is used for Flange Type & Rating, Not available for Length of Extended Parts: 200/250/300mm.
 *4 Not applicable for the combination with code F1, F6 of Explosion proof.
 *5 Not applicable for the combination with code A2 "With external Zero/Span adjustment", Q1 "Safety Transmitter", and Q2 "NAMUR NE43 Compliant Output signal limits" of Option.
 *6 Not applicable for the combination with watted parts mateiral "316L SST" and Flange Type "JIS30K".

Model No.:GTX_ _S-Selection I (I II III IV V VI VII)-Selection II (I II III IV V VI) - Option

Options	No options	XX
	External Zero adjustment *6	A2
	Oil and water free finish	K1
	Oil free finish	K3
	Safety Transmitter *5	Q1
	NAMUR NE43 Compliant Output signal limits:3.8 to 20.5mA (Output 21.6mA/selected upper limit, 3.6mA/selected lower limit)	Q2
	Alarm Output (contact output) *7	Q7
	Custom calibration	R1
	Test report	T1
	Mill certificate	T2
	Traceability certificate	T4
	Non SI Unit	W1

- Note) *5 Not applicable for the combination with code A2, or Q7 of Option.
 *6 Not applicable for the combination with code X "None" of Indicator. Please select "With indicator"..
 *7 Not applicable for the combination with code F2, F5, F6, N2, N5, E2, E5, A2 and A5 of Explosion proof.

DIMENSIONS

Model GTX30S/60S

(Unit : mm)

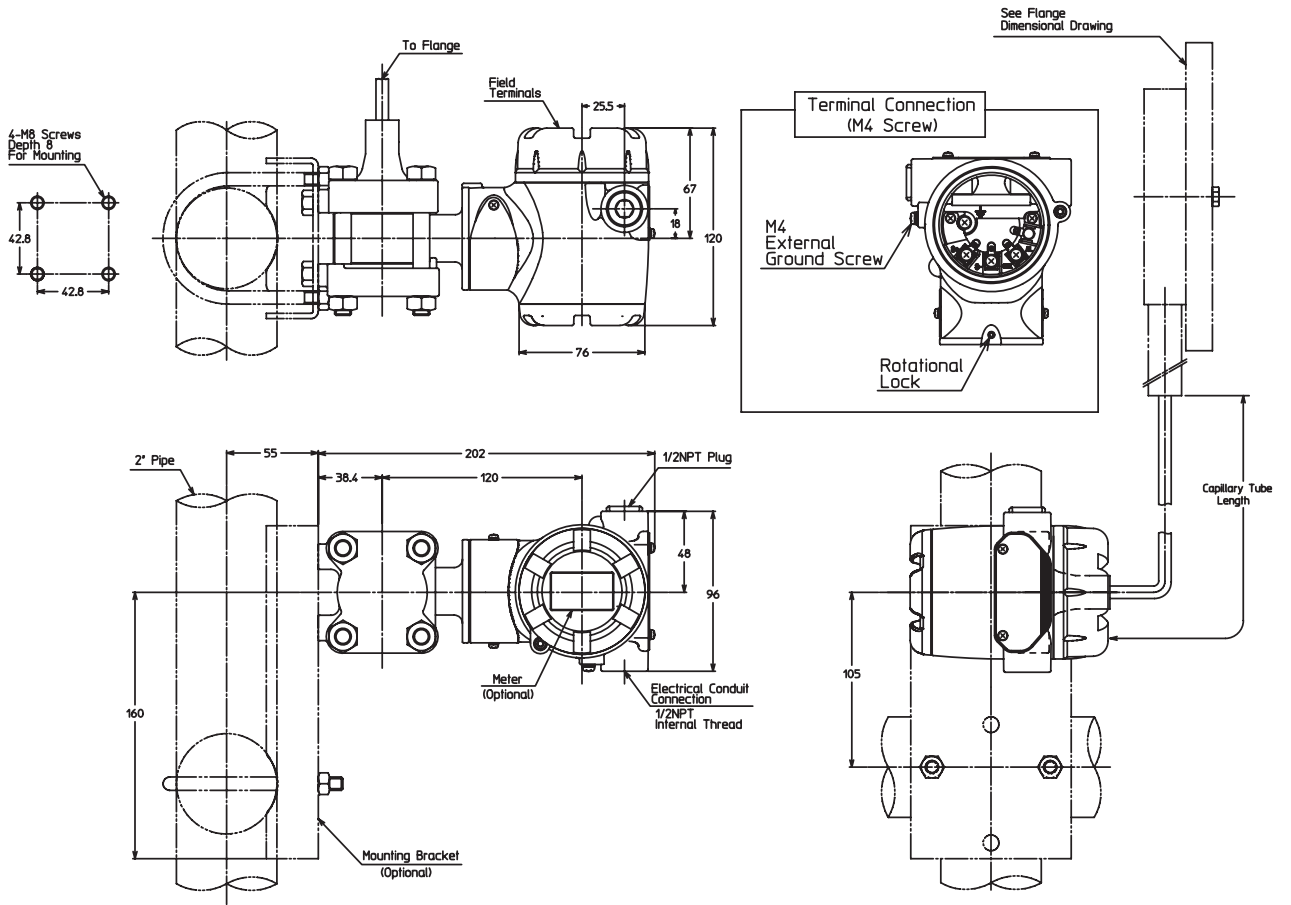
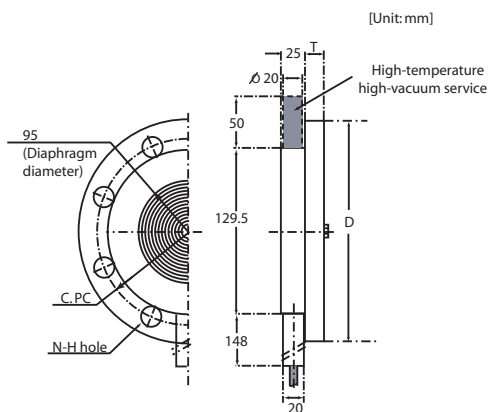

Table of flange dimension

Flush diaphragm flange



Rating	Flange rating	D	T	C	N	H
3 inches / 80 mm	JIS 10K - 80 mm	185	18	150	8	19
	JIS 20K - 80 mm	200	22	160	8	23
	JIS 30K - 80 mm	210	28	170	8	23
	ANSI 150 - 3 inches	190	24	152	4	19
	ANSI 300 - 3 inches	210	28.5	168	8	22
	JPI 150 - 3 inches	190	24	152	4	19
	JPI 300 - 3 inches	210	28.5	168	8	22

Extended diaphragm flange

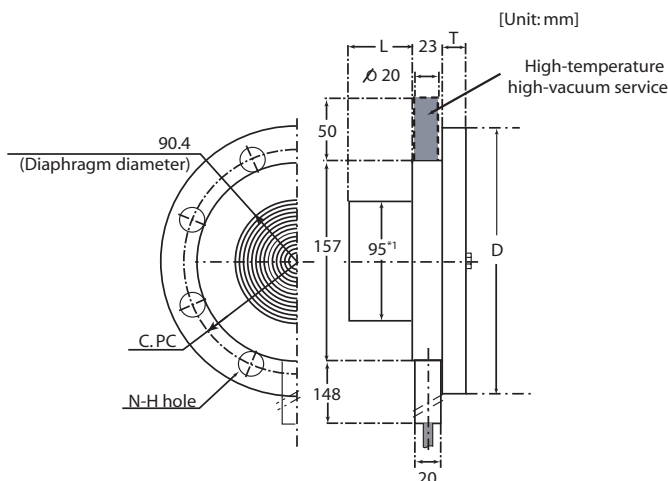

Rating	Flange rating	D	T	C	N	H
4 inches / 100 mm	JIS 10K - 100 mm	210	18	175	8	19
	JIS 20K - 100 mm	225	24	185	8	23
	JIS 30K - 100 mm	240	32	195	8	25
	ANSI 150 - 4 inches	229	24	191	8	19
	ANSI 300 - 4 inches	254	32	200	8	22
	JPI 150 - 4 inches	229	24	191	8	19
	JPI 300 - 4 inches	254	32	200	8	22

Extended length L
50
100
150

Specifications are subject to change without notice.

azbil

Yamatake Corporation
Advanced Automation Company

1-12-2 Kawana, Fujisawa-shi
Kanagawa-ken 251-8522 Japan

URL:<http://www.azbil.com>

No part of this publication may be reproduced or duplicated without the prior written permission of Yamatake Corporation.

May 2008-Y/Y
Mar. 2011 (rev.10)-Y/Y