

AT9000 Advanced Transmitter Absolute Pressure Transmitters

OVERVIEW

AT9000 Advanced Transmitter is a microprocessor-based smart transmitter that features high performance and excellent stability. Capable of measuring gas, liquid, and vapor, and liquid levels, it transmits 4 to 20 mA DC analog and digital signals according to the measured pressure. It can also execute two-way communications between the CommPad (Handy Communicator) or HART® 375 communicator, thus facilitating self-diagnosis, range resetting, and automatic zero adjustment.



FEATURES

Excellent stability and high performance

- Long-term stability is proven in 500,000 installations worldwide.
- Unique characterization and composite semiconductor sensors realize excellent temperature and static pressure characteristics.

Wide measuring range (rangeability)

A wide measuring range is available from a single model. This feature is highly effective in taking measurements over a wide range and reducing the need for inventory.

* Model GTX60A: 35 to 3500 kPa abs. (range ability: 1 to 100)

A diverse lineup

- A wide range of models is available to meet user needs for low, standard, and high pressures.
- A wide variety of corrosion-resistant materials for wetted parts is also available.

Remote communication

- Two-way communication using digital output facilitates self-diagnosis, range resetting, automatic zero adjustment, and other operations.
- HART® protocol communication is available. (Option)

China RoHS

This device is used in the Oil & Gas, Petrochemical, Chemical, Pulp & Paper, Food & Beverage, Machinery, Steel/Metal & Mining, and Automobile industries and therefore does not fall under the China RoHS Legislation.

If this device is used in semiconductor manufacturing equipment, labeling on the device and documents for the China RoHS may be required. If such documents are required, consult a Yamatake representative.

HART® is a registered trademark of the HART Communication Foundation.

APPLICATION**Petroleum / Petrochemical / Chemical**

For measuring pressures and liquid levels in pipes and tanks.

Electric power / City gas / Other utilities

For measurement applications that require high degrees of stability and accuracy.

Pulp and paper

For lines that need transmitters resistant to chemical liquids, corrosive fluids and the like.

Iron and steel / Nonferrous metal / Ceramics

For lines that require stable measurement under strictly controlled (temperature, humidity, etc.) conditions.

Machinery / Shipbuilding

For lines that require stable measurement under strictly controlled (temperature, humidity, etc.) conditions.

FUNCTIONAL SPECIFICATIONS**Type of protection**

NEMA3 and 4X

IEC IP67

FM Explosionproof and Dust Approvals

Explosionproof for Class I, Division 1, Groups A, B, C and D; Class I, Zone 1, AEx d IIC

Dust-Ignitionproof for Class II, III, Division 1, Groups E, F and G

T5 $-40^{\circ}\text{C} \leq T_{amb} \leq +85^{\circ}\text{C}$

Hazardous locations

Indoor / Outdoor Type 4X, IP67

Factory sealed, conduit seal not required for Division applications

Caution - Use supply wires suitable for 5°C above surrounding ambient

FM Intrinsically safe Approval

IS/I,II,III/1/ABCDEFGH/T4; $-40^{\circ}\text{C} \leq T_{amb} \leq +60^{\circ}\text{C}$; 80395278, 80395279, 80395280; Entity; TYPE 4X; IP67 I/O/ AEx ia/IIC/T4; $-40^{\circ}\text{C} \leq T_{amb} \leq +60^{\circ}\text{C}$; 80395278, 80395279, 80395280; Entity; TYPE 4X; IP67

Entity Parameters: $V_{max}(U_i)=30$ Volts, $I_{max}(I_i)=100$ mA, $P_i=1$ W, $C_i=10$ nF, $L_i=0.5$ mH

FM Nonincendive Approval

NI/I/2/ABCD/T4; $-40^{\circ}\text{C} \leq T_{amb} \leq +60^{\circ}\text{C}$; 80395494; NIFW; TYPE 4X; IP67

NI/I/2/IIC/T4; $-40^{\circ}\text{C} \leq T_{amb} \leq +60^{\circ}\text{C}$; 80395494;



NIFW; TYPE 4X; IP67

S/II,III/1/EFG/T4; $-40^{\circ}\text{C} \leq T_{amb} \leq +60^{\circ}\text{C}$;

80395494; NIFW; TYPE 4X; P67

Nonincendive Field Wiring Parameters: $V_{max}(U_i)=30$ Volts, $C_i=10$ nF, $L_i=0.5$ mH

ATEX Flameproof and Dust Certifications

 0344  KEMA 08ATEX0004

II 1/2 G Ex d IIC T6 $T_{process}=85^{\circ}\text{C}$

$-30^{\circ}\text{C} \leq T_{amb} \leq +75^{\circ}\text{C}$ IP66/67

II 1/2 G Ex d IIC T5 $T_{process}=100^{\circ}\text{C}$

$-30^{\circ}\text{C} \leq T_{amb} \leq +80^{\circ}\text{C}$ IP66/67

II 1/2 G Ex d IIC T4 $T_{process}=110^{\circ}\text{C}$

$-30^{\circ}\text{C} \leq T_{amb} \leq +80^{\circ}\text{C}$ IP66/67

II 2 D Ex tD A21 IP66/67 T85 $T_{process}=85^{\circ}\text{C}$

$-30^{\circ}\text{C} \leq T_{amb} \leq +75^{\circ}\text{C}$

II 2 D Ex tD A21 IP66/67 T100 $T_{process}=100^{\circ}\text{C}$

$-30^{\circ}\text{C} \leq T_{amb} \leq +75^{\circ}\text{C}$

II 2 D Ex tD A21 IP66/67 T110 $T_{process}=110^{\circ}\text{C}$

$-30^{\circ}\text{C} \leq T_{amb} \leq +75^{\circ}\text{C}$

Caution - Use supply wires suitable for 5°C above surrounding ambient

ATEX Intrinsic safety and Dust Certifications

 0344  KEMA 07ATEX0200 X

II 1 G Ex ia IIC T4 $T_{PROCESS} = 105^{\circ}\text{C}$

$-30^{\circ}\text{C} \leq T_{amb} \leq +60^{\circ}\text{C}$ IP66 / 67

ELECTRICAL PARAMETERS: $U_i = 30$ V, $I_i = 93$ mA, $P_i = 1$ W, $C_i = 5$ nF, $L_i = 0.5$ mH

II 1 D Ex iaD 20 IP66 / 67 T105 $T_{PROCESS} = 105^{\circ}\text{C}$

$-30^{\circ}\text{C} \leq T_{amb} \leq +60^{\circ}\text{C}$

ATEX Type n and Dust Certifications

 0344  KEMA 07ATEX0200 X

II 3 G Ex nL IIC T4 $T_{PROCESS} = 105^{\circ}\text{C}$

$-30^{\circ}\text{C} \leq T_{amb} \leq +60^{\circ}\text{C}$ IP66 / 67

ELECTRICAL PARAMETERS: $U_i = 30$ V, $C_i = 5$ nF, $L_i = 0.5$ mH

II 2 D Ex tD A21 IP66 / 67 T85 $T_{PROCESS} = 85^{\circ}\text{C}$

$-30^{\circ}\text{C} \leq T_{amb} \leq +75^{\circ}\text{C}$

II 2 D Ex tD A21 IP66 / 67 T100 $T_{PROCESS} = 100^{\circ}\text{C}$

$-30^{\circ}\text{C} \leq T_{amb} \leq +80^{\circ}\text{C}$

II 2 D Ex tD A21 IP66 / 67 T110 $T_{PROCESS} = 110^{\circ}\text{C}$

$-30^{\circ}\text{C} \leq T_{amb} \leq +80^{\circ}\text{C}$

NEPSI Flameproof and Dust Certifications

Ex d IIC T6 DIP A21 $T_A 85^{\circ}\text{C}$ $T_{process}=80^{\circ}\text{C}$ $-40^{\circ}\text{C} \leq T_{amb} \leq +75^{\circ}\text{C}$

Ex d IIC T5 DIP A21 $T_A 100^{\circ}\text{C}$ $T_{process}=95^{\circ}\text{C}$ $-40^{\circ}\text{C} \leq T_{amb} \leq +80^{\circ}\text{C}$

Ex d IIC T4 DIP A21 $T_A 115^{\circ}\text{C}$ $T_{process}=110^{\circ}\text{C}$ $-40^{\circ}\text{C} \leq T_{amb} \leq +80^{\circ}\text{C}$

ENCLOSURE TYPE IP66/67

Certificate No. GYJ071268

NEPSI Intrinsic Safety Certification

Ex ia IIC T4 $T_{process}=105^{\circ}\text{C}$ $-40^{\circ}\text{C} \leq T_{amb} \leq +60^{\circ}\text{C}$
Enclosure IP66 / 67

Electrical Parameters: $U_i=30$ V, $I_i=100$ mA, $P_i=1$ W,

$C_i=13$ nF, $L_i=0.5$ mH

Certificate No. GYJ071269

NEPSI Type n Certification

Ex nL IIC T4 $T_{process}=110^{\circ}\text{C}$ $-40^{\circ}\text{C} \leq T_{amb} \leq +60^{\circ}\text{C}$
Enclosure IP66 / 67

Electrical Parameters: $U_i=30$ V, $I_i=100$ mA, $P_i=1$ W,

$C_i=13$ nF, $L_i=0.5$ mH

Certificate No. GYJ071269

IECEX Flameproof and Dust Certifications

Certificate No. IECEX KEM 08.0001
 Ga/Gb Ex d IIC T6 Tprocess=85°C -30°C ≤ Tamb ≤ +75°C IP66/67
 Ga/Gb Ex d IIC T5 Tprocess=100°C -30°C ≤ Tamb ≤ +80°C IP66/67
 Ga/Gb Ex d IIC T4 Tprocess=110°C -30°C ≤ Tamb ≤ +80°C IP66/67
 Ex tD A21 IP66/67 T85 Tprocess=85°C -30°C ≤ Tamb ≤ +75°C
 Ex tD A21 IP66/67 T100 Tprocess=100°C -30°C ≤ Tamb ≤ +75°C
 Ex tD A21 IP66/67 T110 Tprocess=110°C -30°C ≤ Tamb ≤ +75°C
 Caution - Use supply wires suitable for 5°C above surrounding ambient

IECEX Intrinsic safety and Dust Certifications

IECEX KEM 07.0058X
 Zone 0 Ex ia IIC T4 TPROCESS = 105 °C
 -30 °C ≤ Tamb ≤ +60 °C IP66 / 67
 ELECTRICAL PARAMETERS: Ui = 30 V, Ii = 93 mA, Pi = 1 W, Ci = 5 nF, Li = 0.5 mH
 Ex iaD 20 IP66 / 67 T105 TPROCESS = 105 °C
 -30 °C ≤ Tamb ≤ +60 °C

IECEX Type n and Dust Certifications

IECEX KEM 07.0058X
 Ex nL IIC T4 TPROCESS = 105 °C
 -30 °C ≤ Tamb ≤ +60 °C IP66 / 67
 ELECTRICAL PARAMETERS: Ui = 30 V, Ci = 5 nF, Li = 0.5 mH
 Ex tD A21 IP66 / 67 T85 TPROCESS = 85 °C
 -30 °C ≤ Tamb ≤ +75 °C
 Ex tD A21 IP66 / 67 T100 TPROCESS = 100 °C
 -30 °C ≤ Tamb ≤ +80 °C
 Ex tD A21 IP66 / 67 T110 TPROCESS = 110 °C
 -30 °C ≤ Tamb ≤ +80 °C

EMC Conformity

89/336/EEC, 92/31/EEC, 93/68/EEC Electromagnetic Compatibility (EMC) Directive

Measuring span / Setting range / Working pressure range

	Measuring Span	Setting Range	Working Pressure Range	Overload Resistant Value
GTX 30A	4 to 104 kPa abs {30 to 780 mmHg abs}	0 to 104 kPa abs {0 to 780 mmHg abs}	0.01 to 104 kPa abs {0.1 to 780 mmHg abs} See Figure 1	300 kPa abs {3.0 kgf/cm ² abs}
GTX 60A	35 to 3500 kPa abs {0.35 to 35 kgf/cm ² abs}	0 to 3500kPa abs {0 to 35 kgf/cm ² abs}	0.01 to 3500 kPa abs {0.1 mmHg abs to 35 kgf/cm ² abs} See Figure 1	5250 kPa abs {52.5 kgf/cm ² abs}

Note) With PVC wetted parts, the maximum working pressure is 1.5 MPa {15 kgf/cm²}.

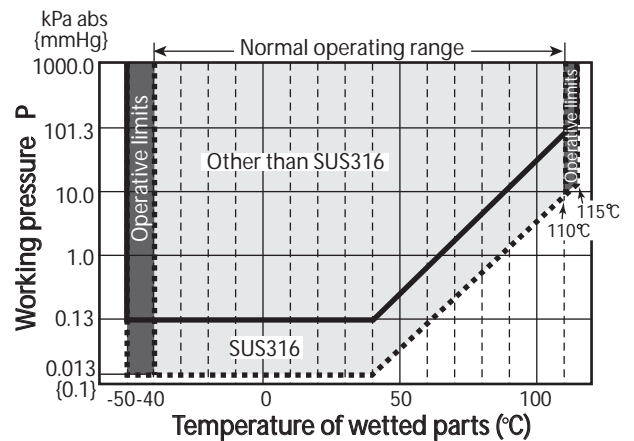

Figure 1 Working pressure and temperature of wetted parts section (for general purpose models)

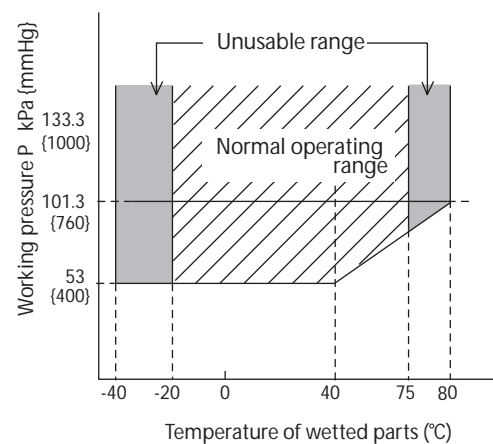

Figure 2 Working pressure and temperature of wetted parts section (for oxygen and chlorine service models)

Supply voltage and load resistance

17.9 to 42V DC. A load resistance of 250 Ω or more is necessary between loops. See Figure 3.

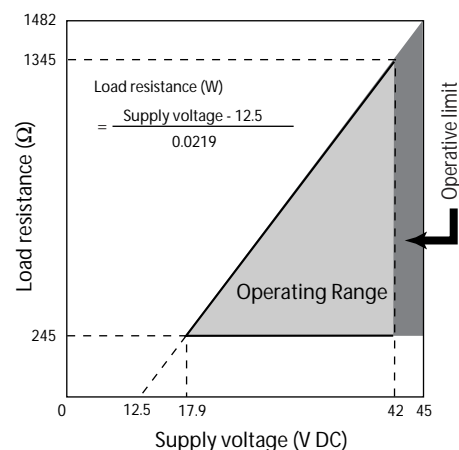

Figure 3 Supply voltage vs. load resistance characteristics

Note) For communication with HART communicator, a load resistance of 250 Ω or more is necessary.

Output

Analog output (4 to 20 mA DC) with DE protocol
Analog output (4 to 20 mA DC) with HART protocol

Output signal

3.6 to 21.6 mA
3.8 to 20.5 mA (NAMUR NE43 compliant)

Failure Alarm

Upper: 21.6 mA or more
Lower: 3.6 mA or less

Ambient temperature limits**Normal operating range**

-40 to 85°C for general purpose models
-10 to 75°C for oxygen and chlorine models
-25 to 80°C for models with digital indicators

Operative limits

-50 to 93°C for general purpose models
-40 to 80°C for oxygen and chlorine models
-30 to 85°C for models with digital indicators

Transportation and storage conditions

-50 to 85°C

Temperature ranges of wetted parts**Normal operating range**

-40 to 110°C for general purpose models
-20 to 75°C for oxygen and chlorine models

Operative limits

-50 to 115°C for general purpose models
-40 to 80°C for oxygen and chlorine models

Ambient humidity limits

5 to 100% RH

Stability against supply voltage change

±0.005% FS/V

Dead time

Approximately 0.4 sec.

Lightning protection

Applicable Standards; IEC 61000-4-5
Peak value of current surge(80/20μ sec.): 6000A

Indicator

The digital LCD indicator (optional) indicates engineering units and can be set freely between -99999 and 99999 (5 digits). For meter calibration, specify the following items when placing your order

- Meter calibration range
 - Meter calibration unit
 - Linear / Square-root for meter indication.
- Various kinds of data can be set using the CommPad or the HART[®]375 communicator.

Bolts and nuts materials (for fastening meter body cover)

Carbon steel (SNB7), 304 SST, 630 SST

Paint**Standard**

Corrosion-resistant paint (Baked acrylic paint)

Corrosion-proof finish

Corrosion-proof paint (Baked epoxy paint), fungus-proof finish

Corrosion-resistant finish (silver paint)

Transmitter case is coated with silver paint in addition to the above corrosion-resistant finish.

OPTIONAL SPECIFICATIONS**Oil free finish**

The transmitter is shipped with oil-free wetted parts.

Adapters for anticorrosion materials

These are adaptor flanges to connect 82 mm pipes made of anticorrosion materials [excluding ASTM B575 (Equivalent to Hastelloy C-276)] to 54 mm general-purpose pipes.

External zero/span adjustment function

The transmitter can be easily zero/span adjusted in the field.

Elbow

This is an adaptor for changing the electrical conduit connection port from the horizontal to the vertical direction, if required by wiring conditions in the field. One or two elbows may be used as needed.

Conformance to Non SI units

We deliver transmitters set to any Non SI units as specified.

Safety Transmitter

Select this option to be used as a component of Safety Instrumented System (SIS).
AT9000 is complied with IEC61508, certified according to Safety Integrity Level2 (SIL-2)

Alarm Output (contact output)

Contact output is prepared as alarm output when alarm (Output Alarm/Sensor Temp. Alarm) condition is detected. It can be set to Normally Open. (When alarm is detected, Contact ON).

Custom calibration

Calibrate for the specified pressure range at the factory.

PHYSICAL SPECIFICATIONS**Materials****Fill fluid**

Silicone oil for general purpose and high-temperature vacuum models
Fluorine oil for oxygen and chlorine models

Center body

316 SST

Transmitter case

Aluminum alloy

Meter body cover

SCS14A (equivalent to 316 SST) or SUSF316, PVC

For Wetted parts**Adapter flange (option)**

SCS14A (equivalent to 316 SST), PVC

Center body

316 SST (Diaphragm 316L SST)
ASTM B574 (Hastelloy C-276 equivalent),
Tantalum, 316L SST

Vents and plugs

316 SST, PVC

Gaskets

FEP

Finish

Baked acrylic paint
Housing light beige (Munsell 4Y7.2/1.3)
Cap dark beige (Munsell 10YR4.7/0.5)

Weight

Approx. 6.8 kg

INSTALLATION

Electrical connection

1/2NPT internal thread, M20 internal thread.

Grounding

Resistance 100 Ω max.

Mounting

Can be installed on a 2-inch horizontal or vertical pipe
(can be directly mounted on a process pipe)

Process connection

Rc1/2, 1/2NPT internal thread and Rc1/4, 1/4NPT internal
thread

PERFORMANCE SPECIFICATIONS**Reference accuracy**

Shown for each item are the percentage ratio for χ (kPa), which is the greatest value of either the upper range value (URV)^{*1}, the lower range value (LRV)^{*2} or the span.

Model GTX30A

(Material of wetted parts: Diaphragm; 316L SST, Others; 316 SST)

Reference accuracy (*3)(*4)		$\pm 0.15\%$	(For $\chi \geq 12kPa$ abs{90 mmHg abs})
		$\pm\left(0.05 + 0.1 \times \frac{12}{\chi}\right)\%$	(For $\chi < 12kPa$ abs{90 mmHg abs})
Ambient Temperature effect (Shift from the set range) Change of 30°C (*3)	Combined shift: (including zero and span shifts)	$\pm 1.2\%$	(For $\chi \geq 12kPa$ abs{90 mmHg abs})
		$\pm\left(0.35 + 0.85 \times \frac{12}{\chi}\right)\%$	(For $\chi < 12kPa$ abs{90 mmHg abs})

Model GTX60A

(Material of wetted parts: Diaphragm; 316L SST, Others; 316 SST)

Reference accuracy (*3)(*4)		$\pm 0.15\%$	(For $\chi \geq 350kPa$ abs{3.5 kgf/cm ² abs})
		$\pm\left(0.05 + 0.1 \times \frac{350}{\chi}\right)\%$	(For $\chi < 350kPa$ abs{3.5 kgf/cm ² abs})
Ambient Temperature effect (Shift from the set range) Change of 30°C (*3)	Combined shift: (including zero and span shifts)	$\pm 1.2\%$	(For $\chi \geq 350kPa$ abs{3.5 kgf/cm ² abs})
		$\pm\left(0.35 + 0.85 \times \frac{12}{\chi}\right)\%$	(For $\chi < 350kPa$ abs{3.5 kgf/cm ² abs})

Model GTX30A

(Material of wetted parts: Diaphragm; ASTM B574 (Hastelloy C-276 equivalent), Tantalum, 316L SST
Others; ASTM B574 (Hastelloy C-276 equivalent), Tantalum, 316L SST)

Reference accuracy (*3)(*4)		$\pm 0.35\%$	(For $\chi \geq 12kPa$ abs{90 mmHg abs})
		$\pm\left(0.25 + 0.1 \times \frac{12}{\chi}\right)\%$	(For $\chi < 12kPa$ abs{90 mmHg abs})
Ambient Temperature effect (Shift from the set range) Change of 30°C (*3) (Range from -5 to 55°C)	Combined shift: (including zero and span shifts)		
		$\pm\left(0.55 + 1.85 \times \frac{24}{\chi}\right)\%$	

Model GTX60A

(Material of wetted parts: Diaphragm; ASTM B575 (Hastelloy C-276 equivalent), Tantalum, 316L SST
Others; ASTM B575 (Hastelloy C-276 equivalent), Tantalum, 316L SST)

Reference accuracy (*3)(*4)		$\pm 0.35\%$	(For $\chi \geq 350kPa$ abs{3.5 kgf/cm ² abs})
		$\pm\left(0.25 + 0.1 \times \frac{350}{\chi}\right)\%$	(For $\chi < 350kPa$ abs{3.5 kgf/cm ² abs})
Ambient Temperature effect (Shift from the set range) Change of 30°C (*3) (Range from -5 to 55°C)	Combined shift: (including zero and span shifts)	$\pm 1.5\%$	(For $\chi \geq 350kPa$ abs{3.5 kgf/cm ² abs})
		$\pm\left(0.35 + 1.15 \times \frac{350}{\chi}\right)\%$	(For $\chi < 350kPa$ abs{3.5 kgf/cm ² abs})

Note) *1: URV denotes the process value for 100% (20 mA DC) output

*2: LRV denotes the process value for 0% (4 mA DC) output.

*3: Within a range of $URV \geq 0$ and $LRV \geq 0$.

*4: Reference accuracy at calibrated condition.

MODEL SELECTION

Model GTX30A(Standard absolute pressure)

Model GTX60A(High absolute pressure)

Model No.:GTX_ _A-Selection I(I II III IV V VI VII)-Selection II(I II III IV V VI)-Option

Basic Model No.

	Measuring span	4.0 to 104kPa abs. (30 to 780mmHg) *5	GTX30A
		35 to 3500kPa abs. (0.35 to 35kgf/cm ²) *6	GTX60A

Selection I

I	Output	4 to 20mA (SFN Communication)	A	
		4 to 20mA (HART Communication)	B	
II	Fill fluid	Regular type (Silicone oil)	A	
		For oxygen service (Fluorine oil)	H	
		For chlorine service (Fluorine oil) *11	J	
III	Material (Meter-body cover, Vent/ Drain plugs)	Meterbody cover	Vent / Drain plugs	
		SCS14A		316 SST
		PVC *1*2*3*4	PVC *1*2*3*4	C
IV	Material (center-body)	316 SST (Diaphragm:316L SST)	A	
		ASTM B575 (Equivalent to Hastelloy C-276) *7	B	
		Tantalum *7	C	
		316L SST	D	
V	Process connections	Rc 1/2, with adapter flange *3	A	
		Rc 1/4, with adapter flange	B	
		Rc 1/4, without adapter flange	C	
		1/2 NPT internal thread, with adapter flange *3	D	
		1/4 NPT internal thread, with adapter flange	E	
		1/4 NPT internal thread, without adapter flange	F	
VI	Process installation	Vertical piping, top connection *4*7	A	
		Vertical piping, bottom connection *4*7	B	
		Horizontal piping, front connection	C	
VII	Bolt/nut	Carbon steel	A	
		304 SST	B	
		630 SST	C	

Selection II

I	Electrical connection	1/2 NPT, Watertight	A
		M20, Watertight *8	B
II	Explosion proof	None	XX
		FM Explosion proof	F1
		FM Intrinsically safe	F2
		FM Nonincendive	F5
		ATEX Explosion proof	A1
		ATEX Intrinsically safe	A2
		ATEX Type n	A5
		IECEX Explosion proof,	E1
		IECEX Intrinsically safe	E2
		IECEX Type n	E5
		NEPSI Explosionproof	N1
		NEPSI Intrinsically safe	N2
NEPSI Type n	N5		
III	Built-in indicating smart meter	None	X
		With indicator	A
IV	Paint	Standard	X
		Corrosion-proof	B
		Corrosion-resistant (Silver coating)	D
V	Burnout feature	UP Scale	A
		DOWN scale	B
VI	Mounting Bracket	None	X
		Carbon steel (L form) *9	3
		304 SST (L form)*9	4
		Carbon steel (Flat form) *10	5
		304 SST (Flat form) *10	6

Note) *1 304 SST bolts and nuts material (-B) must be selected when PVC meterbody cover is selected (-C).The max. working pressure is 1.5MPa.

*2 Applicable for wetted parts of center body material; ASTM B575 or Tantalum.

*3 In case PVC is selected, code A, or D of Process connections should be selected.

*4 In case PVC is selected, code A, or B of Process installation should be selected.

*5 Specify range in abs. Pressure. Correct: 0 to 500mmHg abs. Incorrect: -700mmHg to 1kgf/cm2.

*6 Specify range in abs. Pressure. Correct: 0 to 3kgf/cm2 abs. Incorrect: -1 to 2kgf/cm2 abs.

*7 Code A, or B of Process installation should be selected.

*8 Not applicable for the combination with code F1 "FM Explosion proof" of Explosion proof.

*9 Applicable for wetted parts of centerbody material, 316 SST.

*10 Applicable for wetted parts of centerbody material, ASTM B575, Tantalum, 316L SST.

*11 In case code J is selected, code C "Tantalum" of Material (Centerbody) should be selected.

Model No.:GTX__A-Selection I(I II III IV V VI VII) - Selection II(I II III IV V VI) - Option

Option	XX	No options
	A2	External Zero adjustment *11
	G1	One elbow (left) *6*7*10
	G2	One elbow (right) *6*7*10
	G3	2 elbows *6*8*10
	G4	Long vent/drain plugs
	G6	Side vent/drain top *6*8*10
	G7	Side vent/drain bottom *6
	K1	Oil and water free finish
	K3	Oil free finish *4
	Q1	Safety Transmitter *5
	Q2	NAMUR NE43 Compliant Output sign limits:3.8 to 20.5mA (Output 21.6mA/selected upper limit, 3.6mA/selected lower limit)
	Q7	Alarm Output (contact output)
	R1	Custom calibration
	T1	Test report
	T2	Mill certificate
	T4	Traceability certificate
	T5	NACE certificate *9
	W1	Non SI Unit

- Note) *4 No need to select when Fill Fluid code H, or J is selected.
 *5 Not applicable for the combination with code A2, or Q7 of Option.
 *6 Not applicable for the combination with code A, or B of Process installation.
 *7 Not applicable for the combination with code F1 "FM Explosion proof" of Explosion proof.
 *8 Not applicable for any Explosion proof. Please select code XX "None" of Explosion proof.
 *9 Applicable for "ASTM B575", code B of Material (center body).
 *10 Not applicable for the combination with code B "M20 watertight" of Electrical connection.
 *11 Not applicable for the combination with code X "None" of Indicator. Please select "With indicator".

DIMENSIONS

Model GTX30A/60A (Material (center body): 316 SST

Process Connection : Front Side

(Unit : mm)

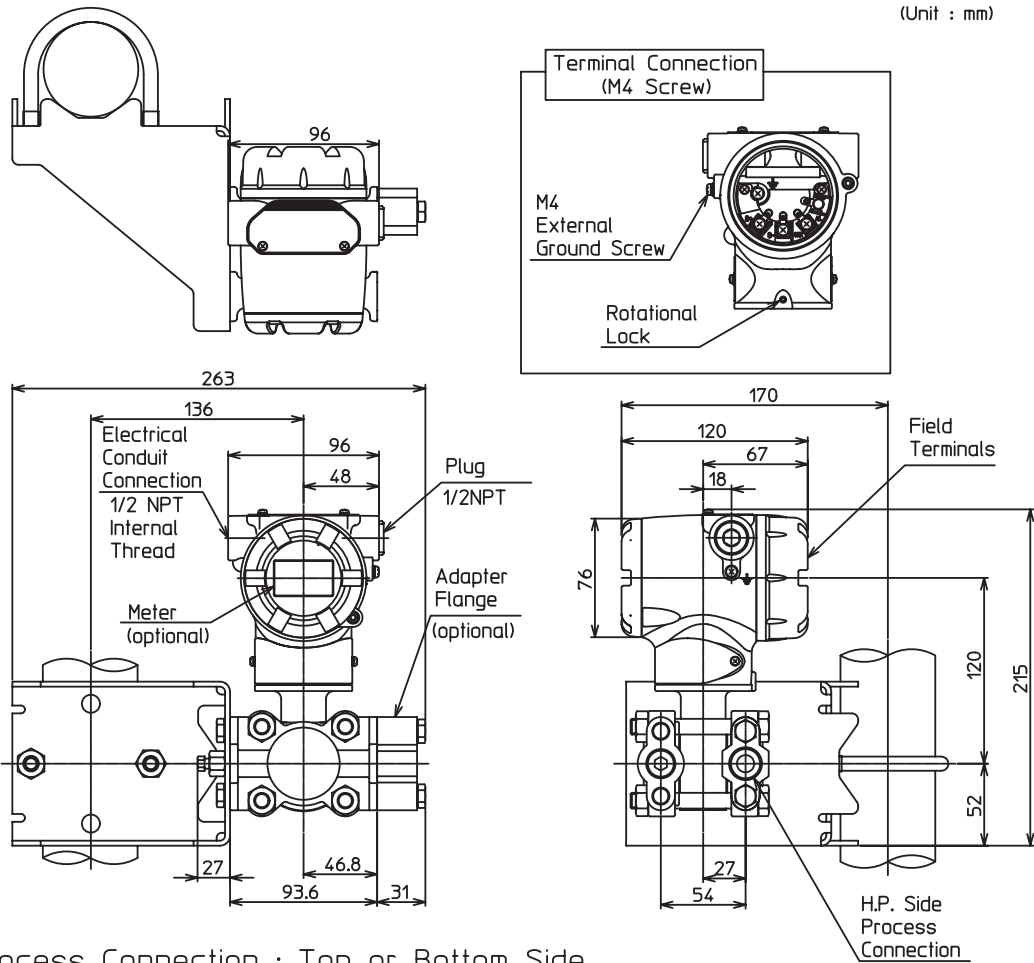

Process Connection : Top or Bottom Side

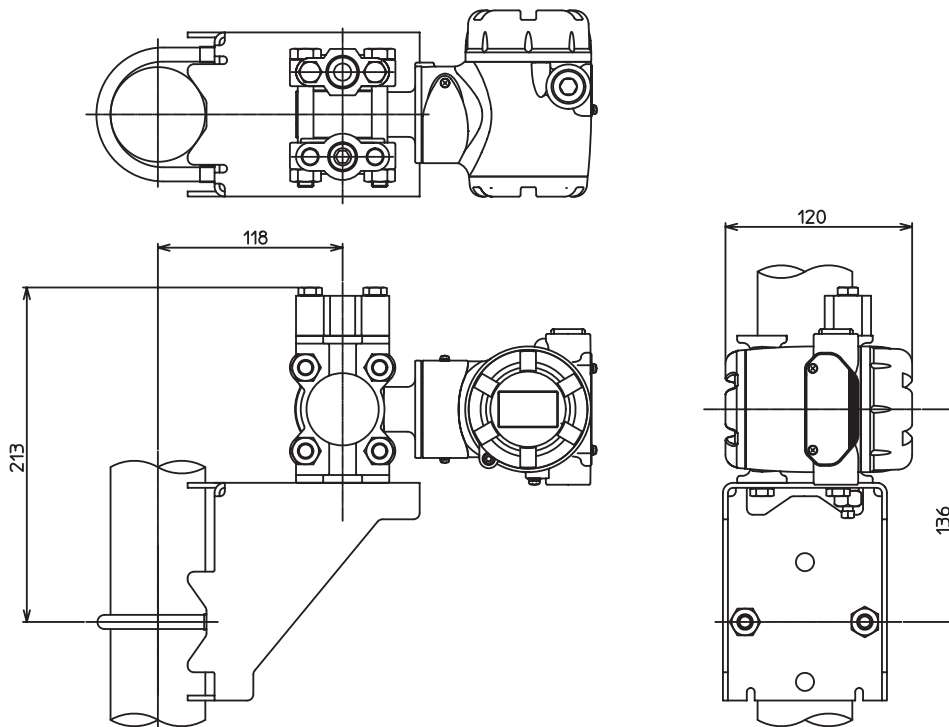

Model GTX30A/60A (Material (center body): ASTM B575, Tantalum, 316L SST)

Process connection: Top or bottom side.

(Unit : mm)

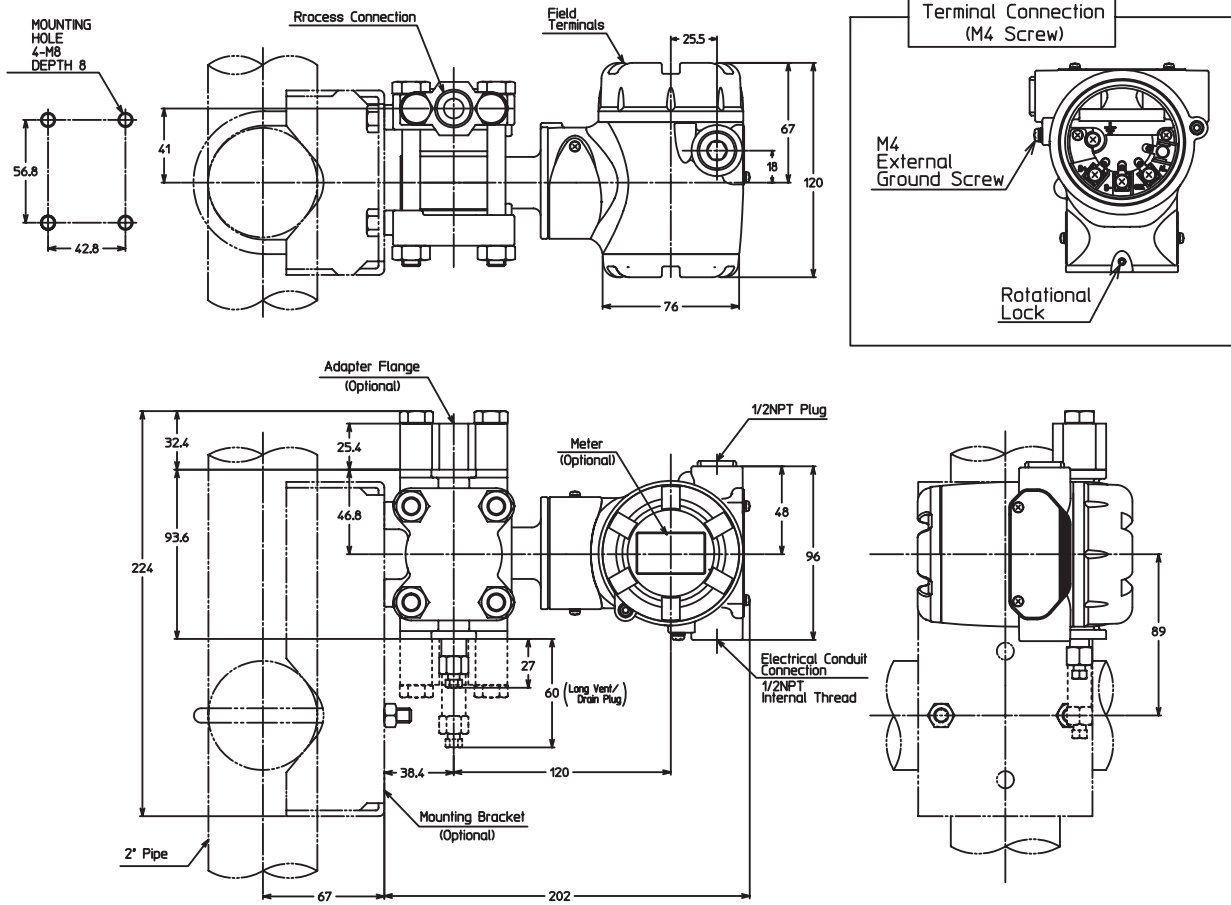

Model GTX30A/60A (Material (Meter body cover, Vent/Drain plugs: PVC)

Process connection: Top or bottom side

(Unit : mm)

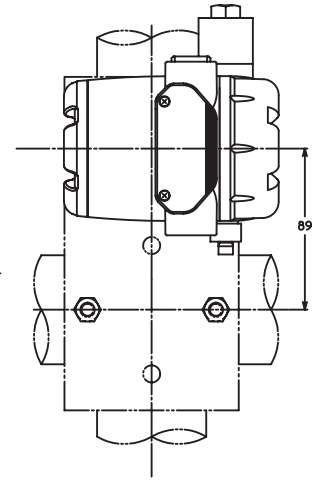
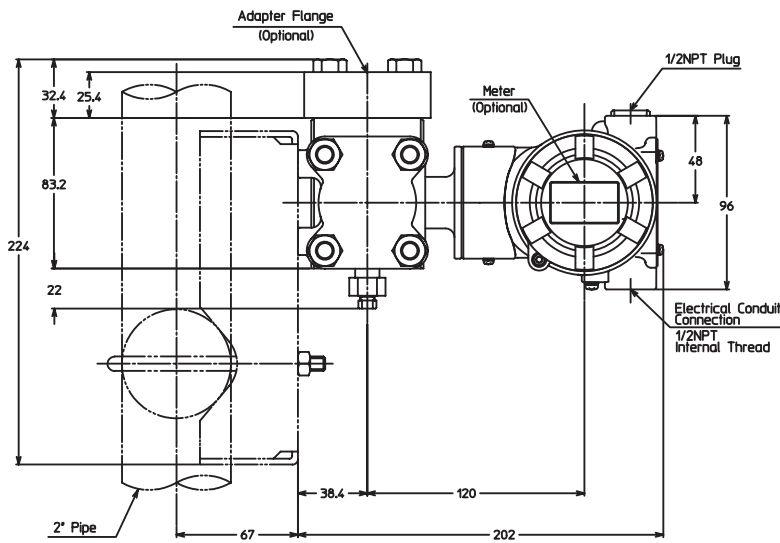
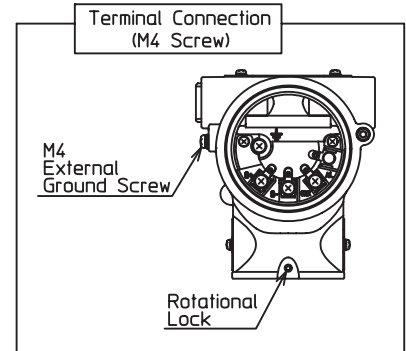
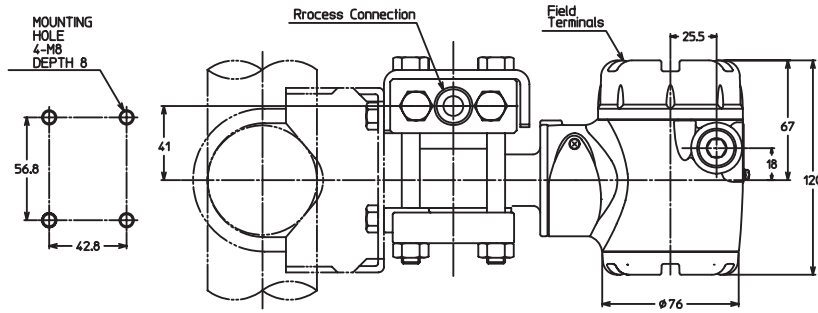

Specifications are subject to change without notice.

azbil

Yamatake Corporation
Advanced Automation Company

1-12-2 Kawana, Fujisawa-shi
Kanagawa-ken 251-8522 Japan

URL:<http://www.azbil.com>

No part of this publication may be reproduced or duplicated without the prior written permission of Yamatake Corporation.

May 2008 –Y/Y
Sept. 2008 (rev.5) –Y/Y