

R	0	06.10.24	3	11.12.09	
1	07.10.26	4	.	.	.
2	08.01.31	5	.	.	.

The followings are some typical examples of mounting SVX100 slide lever type to rotary actuator.

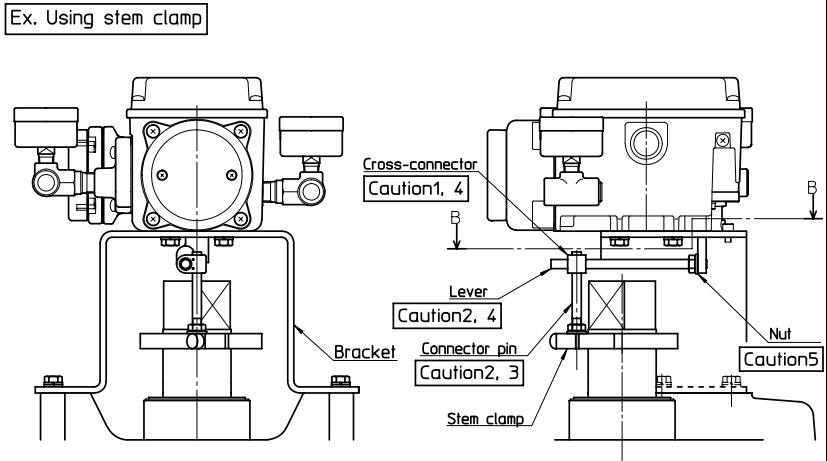

Ex. Others

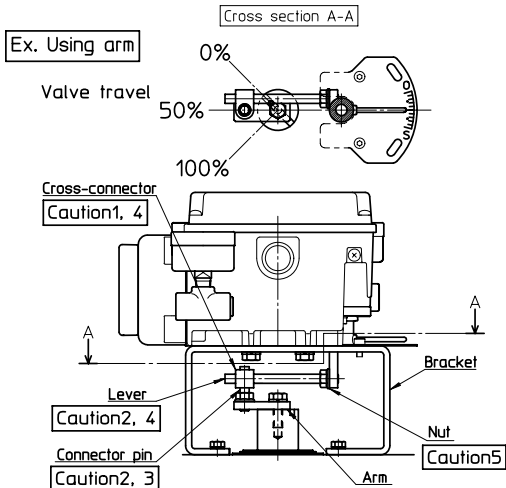
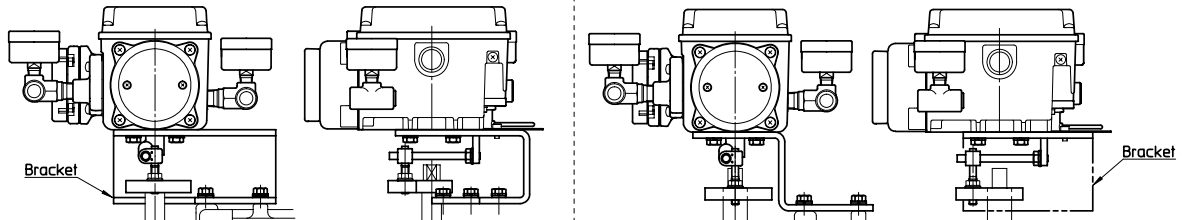

Tightening torque for stainless screw

Size	M5	M6	M8	M10	M12
Torque [N·m]	4.5	7.5	18	37	63

Caution for mounting SVX to valve actuator

⚠ Incorrect mounting SVX could result in the malfunction of product, property damage, or personal injury

<Caution1>

Attach the cross-connector so that the lever is applied for the bearing with marking

<Caution2>

Apply a grease to the lever (the tip of lever about 30mm), connector pin (the tip of lever about 15mm) and bearing

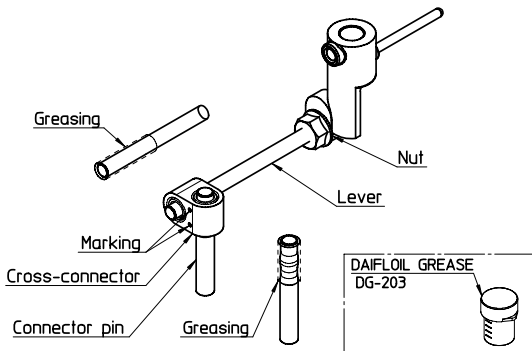

Fig.1 Attachment of cross-connector and greasing

<Caution3>

Attach the connector pin so that it goes through the bearing of cross-connector (Length L becomes about 2mm)

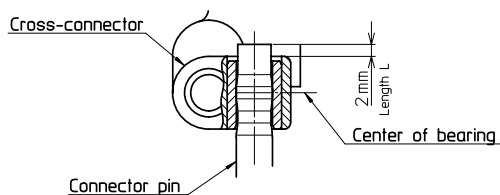

Fig.2 Attachment of connector pin

<Caution for DAILOIL GREASE (DG-203)>

WARNING:

- Local area ventilation is required to provide sufficient ventilation and exhaust wherever Grease is used at temperatures exceeding 200°C to prevent the inhalation of decomposition gases.
- Control is required during processes to make sure the temperature dose not exceed 250°C

CAUTION:

- Decomposition gases may be inhaled when cigarettes that have been exposed to the Grease, directly or on the hands or gloves, are smoked. Any work site where Grease is handled should therefore be a no-smoking zone, and tobacco products should not be allowed in the work area.
- After handling this product, wash the face and hands thoroughly before smoking to prevent exposure of the tobacco to the Grease
- Protective glasses (or goggles) and gloves should be used when handling this product.
- Disposal should be done in accordance with local laws and regulations.
- Do not use for non-industrial applications.

FIRST AID:

- If this product gets into the eyes, wash thoroughly with large amounts of water for at least 15 minutes, and then consult an oculist.
- If the decomposition gas is inhaled, move immediately to fresh air and consult a physician.
- If this product is ingested, consult a physician immediately.
- If this product comes in contact with the skin, wash thoroughly with large amounts of water and soap.

STORAGE:

- Store in a dry, cool place.
- Keep the container tightly sealed during storage to keep out dust and other foreign matter.

<Caution4>

Attach the cross-connector so that the Line C is parallel with Line D as shown in Fig.3

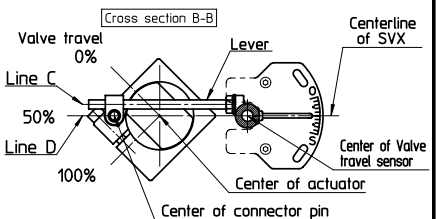

Fig.3 Attachment of cross-connector and lever

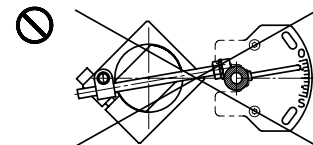

Fig.4 Example of N.G. (cross-connector and lever)

<Caution5>

Do not attach the nut as shown in the Fig.5 (Refer to Fig.1)

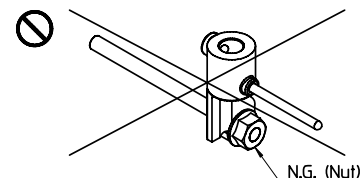

Fig.5 Example of N.G. (Nut)

TITLE
REFERENCE FIGURES FOR MOUNTING BRACKET KIT APPLICATION
(Smart positioner SVX100 series for rotary actuator / slide lever type)

Azbil Corporation

DOCUMENT NO.
SVX100-003-REV.03

REFERENCE DRAWING NO.
80377912-003