

The followings are some typical examples of mounting SVX100 stroke lever type to rotary actuator

Overview figure

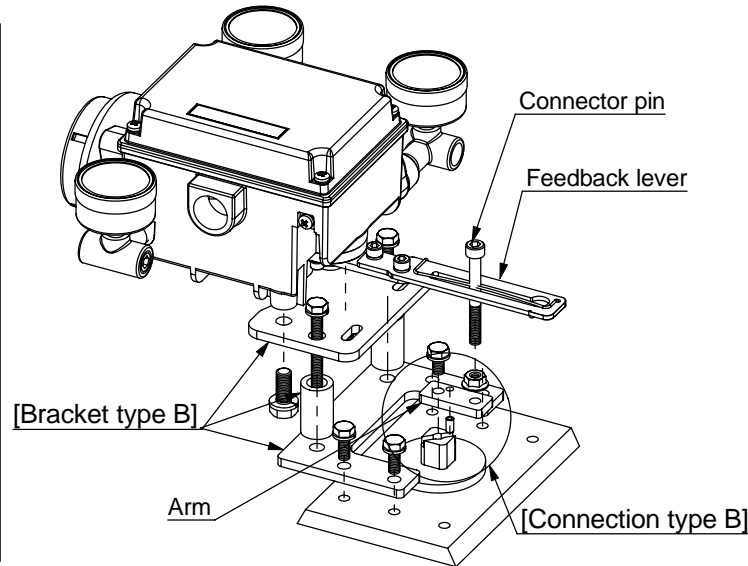

Using extension lever kit

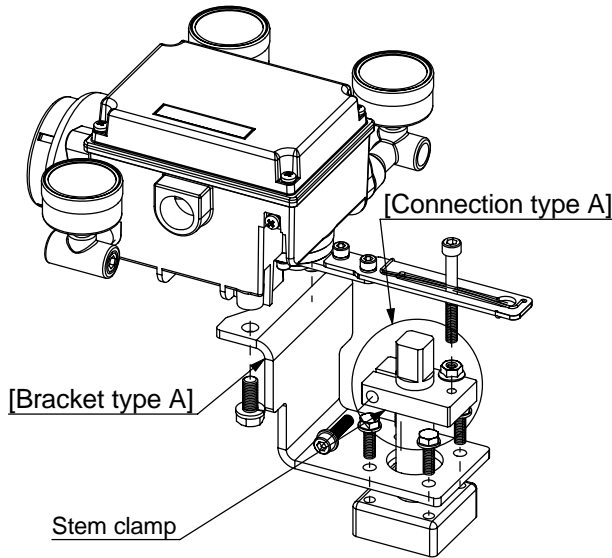
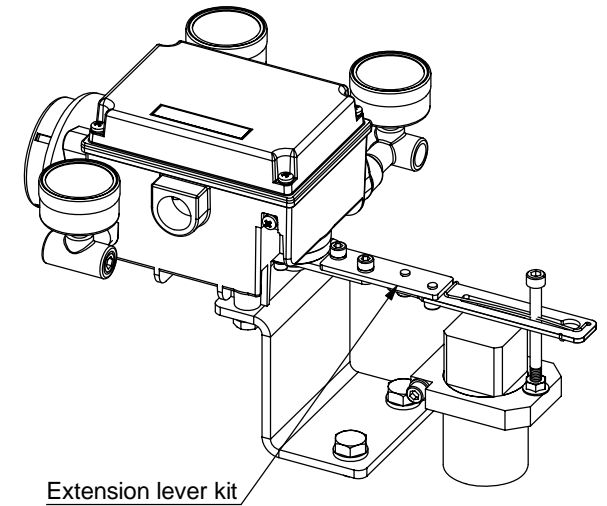

Detail figure for connector pin

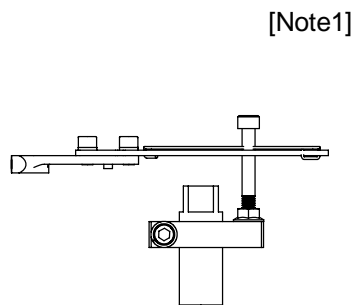

[Note1]

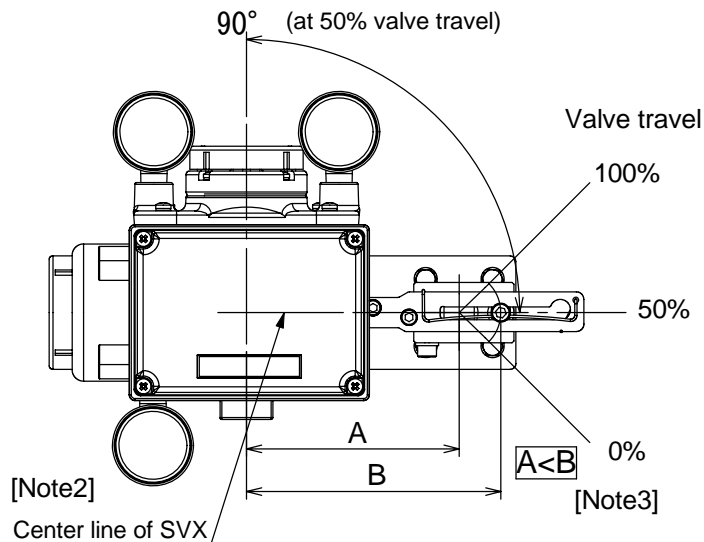

[Note2]

Center line of SVX

Valve travel

100%

50%

0%

A < B

[Note3]

<Note>

1. Please check after attachment that a feedback lever and a connector pin properly connected as shown in Fig.1.
2. SVX should be mounted so that feedback lever comes in parallel with center line of SVX as shown in Fig.2 .
3. Connector pin should be in the position where A < B is kept as shown in Fig.2 .
4. Screws should be tightend referring to the table of tightening torque.

Tightening torque for stainless screw

Size	M5	M6	M8	M10	M12
Tightening torque [N·m]	4.5	7.5	18	37	63

Fig.1 Feedback lever assembly

Fig.2 Front view of SVX