

# SVP3000 Alphaplus

## Smart Valve Positioner

### with HART Communication Protocol

#### Model AVP302

### OVERVIEW

SVP3000 Alphaplus model AVP302 is a current-pneumatic smart valve positioner. The SVP3000 Alphaplus receives a DC current signal from control devices and controls pneumatic valves. In addition to this basic function, the SVP3000 Alphaplus has communication capabilities, an automatic configuration program and self-diagnostics functions that will greatly increase productivity and the efficiency of plant operation. Calibration, configuration and self-diagnostics can be performed by using a HART communicator.

### FEATURES

#### Easy to use

##### • Auto setup

The auto-setup function is a fully-automatic configuration program which specifies the actuator and adjusts the zero and span of the valve. The program can be turned on simply from an external switch so that adjustments to the valve can be performed quickly and safely in hazardous areas.

#### Valve diagnostic (software version 3.0 or newer)

Following parameters can be monitored by HART communicator or Control Valve Maintenance Support System "Valstaff".

- Stick Slip
- Total Stroke
- Travel Histogram
- Cycle Count
- Shut-Off Count
- Max. Travel Speed

#### High reliability

##### • Positive seating

The positive seating function completely shuts off the valve if the input signal becomes lower than previously set. This in turn enhances the full shut-off capabilities of the valves.

##### • Self-diagnostic

The self-diagnostic function provides the user with the ability to check the status of the positioner at any time and to alert in case of failure.



#### Single model for multiple specifications

SVP Alphaplus' settings can be changed without replacing any parts. A single model can be modified to suit any application.

##### • Input range

Configurable to any required range for split range

##### • Flow characteristic

Linear, EQ%, Quick opening or custom user characteristics

##### • Actuator type

Double or single acting actuator (optional reversing relay required)

#### HART communication

HART communicator model 375 can be used for calibration, configuration and self-diagnostics.

#### China RoHS

This device is used in the Oil & Gas, Petrochemical, Chemical, Pulp & Paper, Food & Beverage, Machinery, Steel/Metal & Mining, and Automobile industries and therefore does not fall under the China RoHS Legislation.

If this device is used in semiconductor manufacturing equipment, labeling on the device and documents for the China RoHS may be required. If such documents are required, consult a Yamatake representative.

## **FUNCTIONAL SPECIFICATIONS**

### **Applicable actuator**

- Single and double acting actuator
- Linear and rotary motion actuator

### **Approvals**

#### **TIIS Flameproof approval**

Ex d IIC T6 Approval No. TC16388

#### **FM Explosionproof approval**

**Explosionproof** for Class I, Division 1, Group A, B, C, D

**Dust-ignition** for Class II, Division 1, Group E, F, G

**Suitable** for Class III, Division 1

**Flameproof** for Class I, Zone 1, AEx d IIC T6 at Ambient temperature < 80°C

Approval no. 3001246

Installation should comply with NEC.

#### **FM Intrinsically safe approval**

**Intrinsically safe** for Class I, II, III, Division 1, Group A, B, C, D, E, F, G, T4

**Intrinsically safe** for Class I, Zone 0, AEx ia IIC T4

**Nonincendive** for Class I, Division 2, Group A, B, C, D, T5

**Suitable** for Class II, III, Division 2, Group F, G, T4 Approval No. 3006126

The barriers should be FM recognized types and comply with the following conditions as follows.

Input signal line:  $12.02 \leq V_{max} \leq 30$  V,

$I_{max} = 100$  mA,  $P_{max} = 1$  W,  $C_i = 0.0$  uF,  $L_i = 0.22$  mH

Installation should comply with NEC.

#### **CSA Explosionproof approval**

**Explosionproof** for Class I, Division 1, Group B, C, and D

**Flameproof** for Class I, zone 1, Ex d IIC, T6

**Dust ignition proof** for Class II and III Division 1, Group E, F and G Type 4X,

Approval No. 188352-2500004029, LR113752-6

#### **ISSeP/ATEX Flameproof approval**

EEx d IIC T6 at  $-20^\circ\text{C} < T_{amb} < +70^\circ\text{C}$

IEC IP66 Approval No. ISSep 02ATEX 056

#### **KEMA/ATEX Intrinsically safe approval**

Intrinsic safety: II 1 GD EEx ia IIC T4 T135°C

Approval No. KEMA 00ATEX1111 X

IEC IP66

The barriers should be ATEX certified types and comply with the following condition as follows.

Input circuit (terminals  $\pm$ IIN)

$U_i = 30$  V,  $I_i = 100$  mA (resistively limited),

$P_i = 1$  W,  $C_i = 26$  nF,  $L_i = 0.2$  mH

Both circuits shall be considered to be connected to ground from a safety point of view.

#### **NEPSI Flameproof approval**

Ex d IIC T6, with NEPSI Dust ignition DIP A20 T6 IP66

Flameproof cable gland which is NEPSI Ex d II C T6 recognized is recommended.

### **NEPSI Intrinsically safe approval**

Ex ia IIC T4-T6

The barriers should be NEPSI certified types and comply with the following condition as follows.

Input circuit (terminals  $\pm$ IIN)

$U_i = 30$  V,  $I_i = 95$  mA

$P_i = 0.66$  W,  $C_i = 0$

$L_i = 0.2$  mH

Output circuit (terminals  $\pm$ IOUT)

$U_i = 30$  V,  $I_i = 95$  mA

$P_i = 0.66$  W,  $C_i = 0$

$L_i = 0.2$  mH

### **Combination of NEPSI Flameproof and Intrinsically safe**

When used as NEPSI Flameproof, it complies NEPSI Flameproof approval as above,

When used as NEPSI Intrinsically safe, it complies NEPSI Intrinsically safe approval as above.

### **Control signal input**

4-20 mA DC (Configurable to any required range for split range.)

Minimum driving current : 3.85mA

Minimum 12.0 Volts available at the positioner

### **Input resistance**

600  $\Omega$  max / 20 mA DC

### **Output characteristics**

- Linear, Equal percentage, Quick opening

- Custom user characteristics (16 points)

### **Stem travel range**

Feedback Lever Angle  $\pm 4^\circ$  to  $\pm 20^\circ$

### **Bypass operation**

Auto/Manual external switch (For single acting actuator only)

### **Air supply pressure**

140 to 700 kPa {1.4 to 7.0 kgf/cm<sup>2</sup>}

### **Air consumption**

4 l/min(N) maximum at 140 kPa {1.4 kgf/cm<sup>2</sup>}

5 l/min(N) maximum at 280 kPa {2.8 kgf/cm<sup>2</sup>}

6 l/min(N) maximum at 500 kPa {5.0 kgf/cm<sup>2</sup>}

10 l/min(N) maximum at 400 kPa {4.0 kgf/cm<sup>2</sup>}

for double acting actuator

### **Maximum air deliver flowrate**

110 l/min(N) at 140 kPa {1.4 kgf/cm<sup>2</sup>}

250 l/min(N) at 400 kPa {4.0 kgf/cm<sup>2</sup>}

for double acting actuator

### **Output balanced pressure**

55  $\pm$  5% for double acting actuator only

### **Lightning protection**

Peak value of voltage surge: 12 kV

Peak value of current surge: 1000 A

### **Vibration tolerance**

2G, 5 to 400 Hz

(with standard mounting kit on Yamatake HA actuator)

**Ambient temperature limits**

-40°C to 80°C for general model

TIIS Flameproof	:	-40°C to 55°C
FM Explosionproof	:	-40°C to 80°C
FM Intrinsically safe	:	-40°C to 80°C
ISseP/ATEX Flameproof	:	-20°C to 70°C
KEMA/ATEX Intrinsically safe:	:	-40°C to 60°C
CSA Explosionproof	:	-40°C to 80°C
NEPSI Flameproof	:	-40°C to 60°C
NEPSI Intrinsically safe	:	
For Ex ia IIC T6	:	-40°C to 40°C
For Ex ia IIC T5	:	-40°C to 60°C
For Ex ia IIC T4	:	-40°C to 80°C

**Ambient humidity limits**

10% to 90% RH

**CE conformity****Electromagnetic compatibility**

EN61326 : 2006 (CE Marking)

**Configuration tools**

- HART communicator model 275 (According to need, please update a software and device description files.)
- Model SFC160 or SFC260 (SFC Smart Field Communicator, software version 7.8 or newer)

**PERFORMANCE SPECIFICATIONS****Accuracy \*1**

For 8 mA ≤ input signal span &lt; 16 mA

± 1% F.S. (± 2.5% with custom output characteristics)

For 4 mA ≤ input signal span &lt; 8 mA

± 1.5% F.S.

*Note)\*1: Refer to Table 3. Because accuracy varies depending on the combination of actuator size and travel.*

**PHYSICAL SPECIFICATIONS****Enclosure classification**

JIS C0920 watertight, NEMA type 4X, IEC529 IP66

**Finish**

Baked acrylic

**Color**

Dark blue

**Material**

Cast aluminum

**Weight****For single acting actuator**

Without Pressure regulator with filter: 2.5 kg

With Pressure regulator with filter : 3.2 kg

**For double acting actuator**

Without Pressure regulator with filter: 2.8 kg

With Pressure regulator with filter : 3.5 kg

**INSTALLATION****Air connections**

Rc1/4 or 1/4NPT internal thread

**Electrical connections**

G1/2 or 1/2NPT internal thread

**Conditions of supply air (JIS C1805-1 (2006))****Particles**

Maximum diameter 3 μm

**Oil mist**

Less than 1 ppm at mass

**Humidity of the air supply**

The dew point should be at least 10°C lower than the temperature of this device.

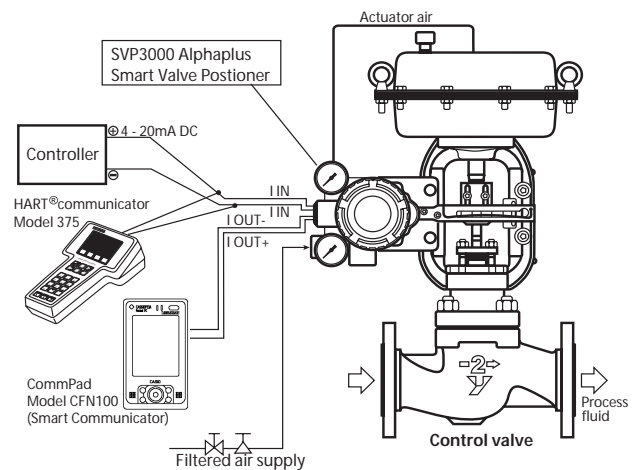
**Typical installation****Figure 1 Wiring for model AVP302**

**MODEL SELECTION**

<b>AVP302</b>	(1)	(2)	(3)	(4)	(5)	-	(6)	(7)	(8)	(9)	-	(10)
---------------	-----	-----	-----	-----	-----	---	-----	-----	-----	-----	---	------

Analog signal (4 to 20 mA DC) with HART communication protocol.

- Note) \*1: One piece of JIS Flameproof cable gland is attached.  
 \*2: Standard finish is equivalent to paint specifications Y138A. Corrosion proof is equivalent to paint specifications Y138B.  
 \*3: No domestic sales in Japan due to Non-SI unit.  
 \*4: Select model AVP (integral type) only when the direction of drain of the pressure regulator with filter on the control valve is downward (ground).  
 \*5: For JIS Flameproof model, this elbow is put on the supplied cable gland.

	Connection	Air piping connection	Electrical connection	Mounting thread	Code
<b>(1) Structure</b>	Water-proof	Rc1/4	G1/2	M8	X
	Water-proof	1/4NPT internal	1/2NPT internal	5/16-18	P
	Water-proof	1/4NPT internal	M20 × 1.5	M8	Q
	TIIS Flameproof with cable gland *1	Rc1/4	G1/2	M8	E
	FM Explosionproof and Flameproof	1/4NPT internal	1/2NPT internal	5/16-18	F
	FM Intrinsically safe	1/4NPT internal	1/2NPT internal	5/16-18	M
	CSA Exprosnproof	1/4NPT internal	1/2NPT internal	5/16-18	A
	ISSeP/ATEX Flameproof	1/4NPT internal	M20 × 1.5	M8	C
	KEMA/ATEX Intrinsically safe	1/4NPT internal	M20 × 1.5	M8	L
	NEPSI Flameproof	1/4NPT internal	1/2NPT internal	5/16-18	B
	NEPSI Flameproof	1/4NPT internal	M20 × 1.5	M8	N
	NEPSI Intrinsically safe and Flameproof	1/4NPT internal	1/2NPT internal	5/16-18	R
NEPSI Intrinsically safe and Flameproof	1/4NPT internal	M20 × 1.5	M8	W	
<b>(2) Finish</b>	Standard (Baked acrylic) *2				S
	Corrosion proof (Baked epoxy) *2				B
	Silver finish (Baked acrylic) *2				D
<b>(3) Positioner action</b>	Direct action - Air pressure increases with control signal increase				D
	Reverse action - Air pressure decreases with control signal increase				R
<b>(4) Supply air pressure classification</b>	Air supply range	Pressure gauge scale	Max regulator setting		
	130≤Ps≤150 kPa {1.3≤Ps≤1.5 kgf/cm <sup>2</sup> }	200 kPa {2 kgf/cm <sup>2</sup> }	400 kPa {4 kgf/cm <sup>2</sup> }		1
	150<Ps≤300 kPa {1.5<Ps≤3.0 kgf/cm <sup>2</sup> }	400 kPa {4 kgf/cm <sup>2</sup> }	400 kPa {4 kgf/cm <sup>2</sup> }		2
	300<Ps≤400 kPa {3.0<Ps≤4.0 kgf/cm <sup>2</sup> }	600 kPa {6 kgf/cm <sup>2</sup> }	400 kPa {4 kgf/cm <sup>2</sup> }		3
	400<Ps≤450 kPa {4.0<Ps≤4.50 kgf/cm <sup>2</sup> }	600 kPa {6 kgf/cm <sup>2</sup> }	700 kPa {7 kgf/cm <sup>2</sup> }		4
450<Ps≤700 kPa {4.5<Ps≤7.0 kgf/cm <sup>2</sup> }	1000 kPa {10 kgf/cm <sup>2</sup> }	700 kPa {7 kgf/cm <sup>2</sup> }		5	
<b>(5) Scale unit (Pressure gauge)</b>	kPa				A
	kgf/cm <sup>2</sup> *3				B
	MPa				C
	bar				D
	psi *3				E

<b>(6) Pressure regulator with filter</b>	No selection				X
	Model KZ03 pressure regulator with filter (Mounted on positioner) *4				1
	Model KZ03 pressure regulator with filter (with bracket for separated mount)				2
<b>(7) Material of Bracket / Bolts</b>	No selection				X
	Stainless steel / Stainless steel				D
<b>(8)(9) Actuators (for bracket)</b>	No selection				XX
	For single acting actuator				Refer to Table 1
	For double acting actuator				Refer to Table 2

<b>(10) Option (Plural selection available)</b>	No selection				X
	Universal elbow explosion-proof (SUS304 G1/2) 1 pc. *5				A
	Stainless filter for KZ03 (Pressure regulator with filter)				K
	Filter (Screen for air-exhaust port)				H
	Reversing relay for double acting actuator				W

Configuration Following shows default and optional settings of each configurable parameter of SVP.

- |                          |                          |   |
|--------------------------|--------------------------|---|
| 1. Input control signal  | 4 to 20 mA               | The minimal span for custom range = 4mA         |
| 2. Output characteristic | Liner                    | EQ or QO can be ordered or set by user.         |
| 3. Valve action          | Direct (Plug above seat) | Reverse (Plug below seat) can be ordered or set |

Table 1 Mounting bracket for single acting actuator

(8)(9) Mounting bracket for pneumatic actuators	Code
PSA1, PSA2, PSK1	YS
PSA3, PSA4 / VA1 to VA3 produced after Apr.'83 *8	YQ
PSA3, PSA4 for existing valves produced on/before 1999	YY
PSA6 / VA4 to VA6 produced after Apr.'83 *8	YL
PSA7	Y8
HA1	YA
HA2, HA3, HL2, HL3	YT
HA4, HL4	YN
HK1, VM1 *12	YK
VM12 for model VSP *13	YB
VR1	YV
VR2, VR3	YR
VR3H	Y6
RSA1	YF
RSA2	YU
GOM 83S, GOM 84S, GOM 103S	YG
GOM 124S	YM
VA1 - VA3 (for old-model motion connectors) Produced on/before Apr.'83 800-1, 800-3 *9	YW
VA4 - VA5 (for old-model motion connectors) Produced on/before Apr.'83 800-4, 800-5 *9	YJ
Motoyama Mfg. 2800 series 240, 280, 330, Nihon Koso A100 series 270, 320 *6	TA
Motoyama Mfg. 2800 series 400, 500S, 500L, Nihon Koso A100 series 400, 500 *6	TB
Motoyama Mfg. 2800 series 650S, 650L *6	TC
Motoyama Mfg. 2800 series 240, 280, 330 (with side manual)	TD
Motoyama Mfg. 2800 series 400, 500S, 500L (with side manual)	TE
Motoyama Mfg. 2800 series 650S, 650L (with side manual)	TF
Motoyama Mfg. 3800 series (multi-spring type) N24, N28, N33S	TJ
Motoyama Mfg. 2922 series (Gyrol-I) G.R.I 280H, 330H, 400HS, 400H, 500H	TL
Motoyama Mfg. 3993 series (Gyrol-II) 2911-1M series 280, 330, 400	TG
Nihon Koso 5100L series 240, 280 *6	TP
Nihon Koso 5200L series 218, 270, 350 *6	TR
Masoneilan 37, 38 series #9, #11 *6	MA
Masoneilan 37, 38 series #13 *6	MB
Masoneilan 37, 38 series #15, #18 *6	MC
Masoneilan 37, 38 series #15, #18 (with side manual)	MF
Masoneilan type 35002 series Camflex II #41/2, #6, (Valve size 1 inch - 4 inches)	MG
Masoneilan type 35002 Camflex II #7 (Valve size 6 inches - 12 inches)	MH
Fisher 657, 667 series size 40	FB
Fisher 657, 667 series size 45, 50	FC
Tyco Flow Control Japan AK09S, AK12S, AK15S	KA
Tyco Flow Control Japan AG06S, AGN06S	KG
Tyco Flow Control Japan AG09S, AGN09S	KH
Tyco Flow Control Japan AG13S, AGN13S	KJ
Tyco Flow Control Japan AW13S	KV
Tyco Flow Control Japan AW17S	KW
Tyco Flow Control Japan AW20S	KT
KITZ B series BS-2, BSW-2	B2
KITZ B series BS-3, BSW-3, Hisaka TS-6	B3
KITZ B series BS-4, BSW-4	B4
KITZ B series BS-5, BSW-5	B5
KITZ B series BS-6, BSW-6	B6
Xomox (EL-O-MATIC) E25, 40, 65, 100, 200, 350	RA
Xomox (EL-O-MATIC) E600, 950, 1600, P2500, P4000	RB
Hisaka TS-1	H1
Hisaka TS-2	H2
Hisaka TS-3	H3
Hisaka TS-4, 5	H4
Tomoe Valve Z series Z-06S, 08S, 11S, 13S	EA
Tomoe Valve T-matic 3Q-1, 2, 3, 4	E3

Table 2 Mounting bracket for double acting actuator

(8)(9) Mounting bracket for pneumatic actuators	Code
VP5, 6 *7	Y1
VP7 *7	Y7
SLOP560, 1000, 1000X *7 *16	Y2
SLOP1500, 1500X *7 *16	Y3
DAP560, 1000, 1000X *7 *16	Y4
DAP1500, 1500X *7 *16	Y5
Tyco Flow Control Japan AK09, AK12, AK15 *7	KA
Tyco Flow Control Japan AG06, AGN06 *7	KG
Tyco Flow Control Japan AG09, AGN09 *7	KH
Tyco Flow Control Japan AG13, AGN13 *7	KJ
Tyco Flow Control Japan AW13 *7	KV
Tyco Flow Control Japan AW17 *7	KW
Tyco Flow Control Japan AW20 *7	KT
KITZ B series B-2 *7	B2
KITZ B series B-3 *7	B3
KITZ B series B-4 *7	B4
KITZ B series B-5 *7	B5
KITZ B series B-6 *7	B6
Xomox (EL-O-MATIC) E25, 40, 65, 100, 200, 350 *7	RA
Xomox (EL-O-MATIC) E600, 950, 1600, P2500, P4000 *7	RB
Tomoe Valve Z series Z-06, 08, 11, 13 *7	EA
Tomoe Valve T-matic 3I-1, 2, 3, 4 *7	E3
T. V. VALVE AT4-80 *7	V1
T. V. VALVE AT4-100 *7	V2
T. V. VALVE AT4-120 *7	V3
T. V. VALVE AT4-150 *7	V4
T. V. VALVE AT4-180 *7	V5

- Note) \*6 Select in the case of without manual handle or with manual handle mounted on top of the actuators.  
 \*7 In case of double acting actuator, a reversing relay unit required.  
 \*8 Select "YW" or "YJ" for old-type motion connectors. (Produced on/before Apr.'83)  
 \*9 Consult with sales representative in case of no mounting hole on the side of valve yoke.  
 \*12 In case "VM" type actuator is required following conditions, 1. select model "VCT" for the body, 2. the existing positioner should be HEP or VPE, 3. yoke should be model HK. If another spec. is required, contact your sales representative.  
 \*15 For model VSP (PVC body), an additional support bracket is required for the AVP.  
 \*16 Contact a sales representative if a bracket for model VFR (FloWing) or butterfly valve is required.

Table 3 Standard travel range and accuracy

Actuator	Travel (mm)	Accuracy [% F.S.]
PSA1, 2	14.3, 20, 25	1
PSA3, 4	20, 38	1
HA1	6, 8, 10	3
	14.3, 25	1
HA2	10	3
	14.3, 25, 38	1
HA3	14.3	3
	25, 38, 50	1
HA4	14.3	3
	25, 38, 50, 75	1
VA5	25, 37.5, 50, 75, 100	1
VA6	14.3	3
PSA6, 7	25, 37.5, 50, 75, 100	1
HK1	10	3
	19	1
PSK1		

**DIMENSIONS**

For single acting actuator without pressure regulator with filter

[Unit: mm]

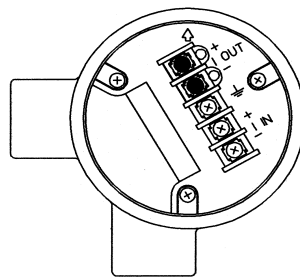
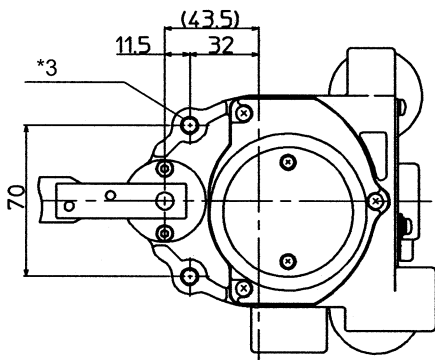
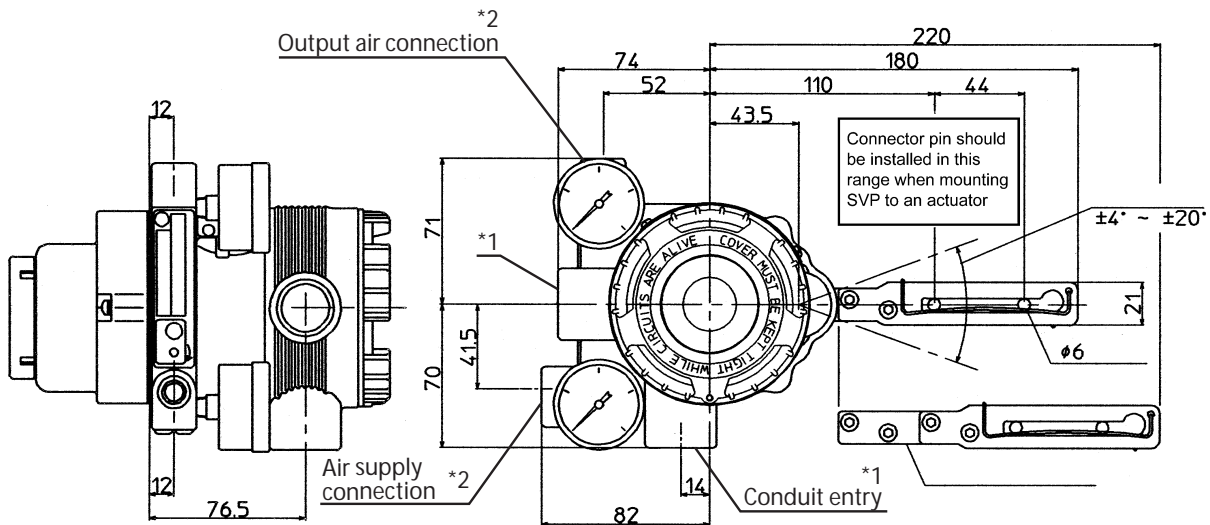
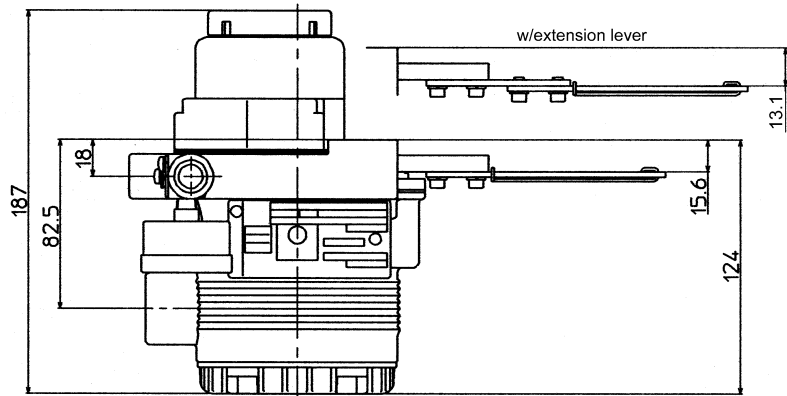

Terminal connections  
Terminal screw size M4

Extension lever	Actuator model	Code
No	PSA1, 2, PSK1	YS
	HA1	YA
	HA2, 3	YT
	HK1	YK
Yes	PSA3, 4	YQ
	VA1 to 3	
	PSA6	YL
	PSA7	Y8
	HA4	YN
	VA4 to 6	YL
	VR1	YV
	VR2, 3	YR
	GOM83S, 84S, 103S	YG
	GOM124S	YM

Mounting plate reference dimension

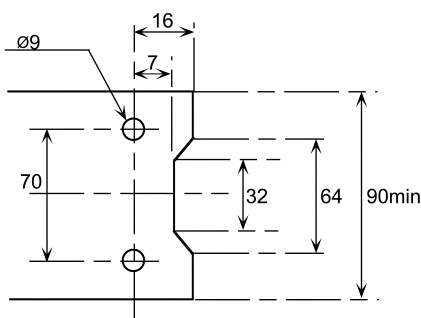

Types	Electrical connection	Air piping connection	Mounting threads
TIIS approval or water-proof type	G1/2	Rc1/4	M8
FM, NEPSI and CSA approvals or water-proof type	1/2NPT	1/4NPT	5/16-18UNC
ATEX and NEPSI approvals or water-proof type	M20×1.5	1/4NPT	M8
Parts on drawings	*1	*2	*3

For single acting actuator with pressure regulator with filter

[Unit: mm]

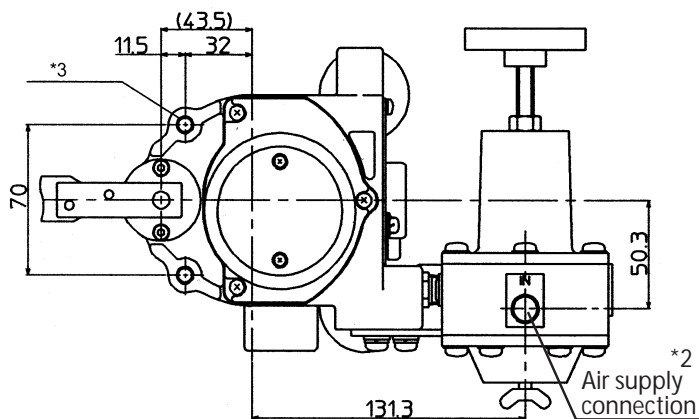
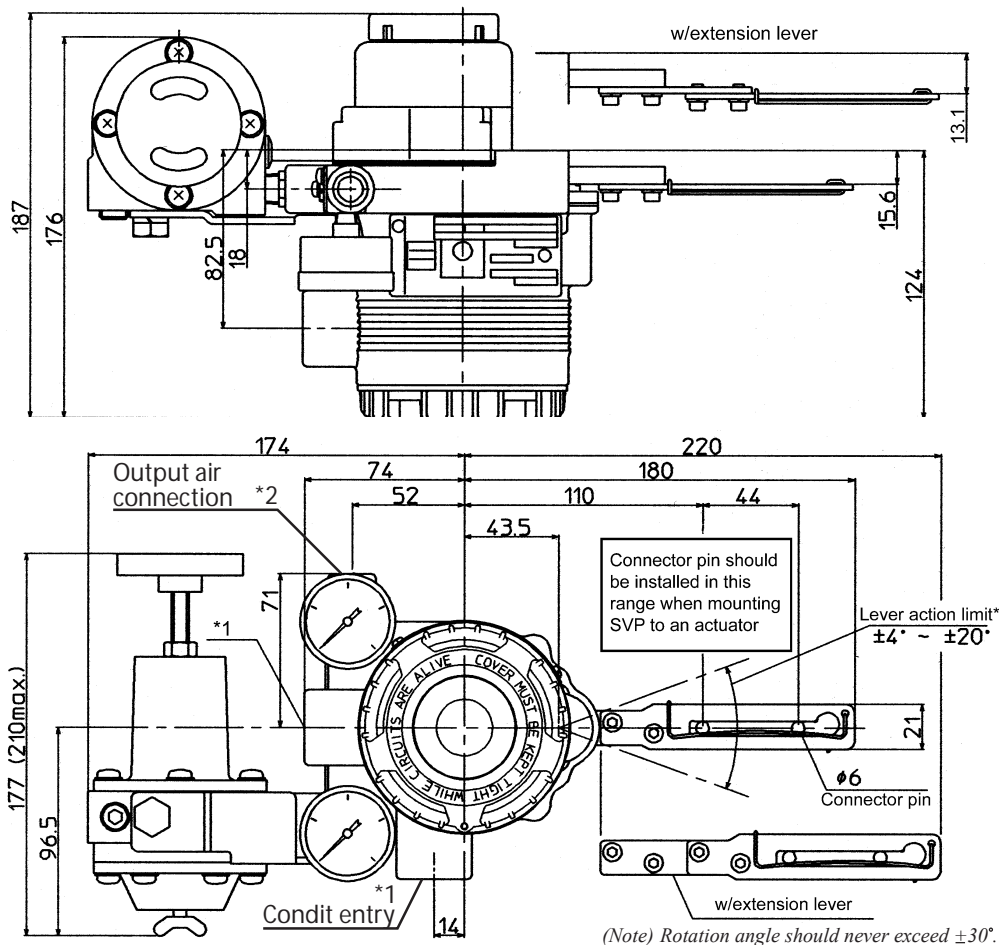

Extension lever	Actuator model	Code
No	PSA1, 2, PSK1	YS
	HA1	YA
	HA2, 3	YT
	HK1	YK
Yes	PSA3, 4	YQ
	VA1 to 3	YQ
	PSA6	YL
	PSA7	Y8
	HA4	YN
	VA4 to 6	YL
	VR1	YV
	VR2, 3	YR
	GOM83S, 84S, 103S	YG
	GOM124S	YM

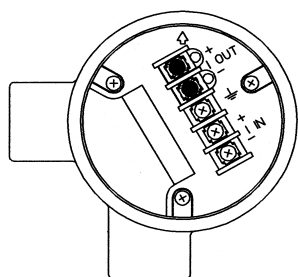

Types	Electrical connection	Air piping connection	Mounting threads
TIIS approval or water-proof type	G1/2	Rc1/4	M8
FM, NEPSI and CSA approvals or water-proof type	1/2NPT	1/4NPT	5/16-18UNC
ATEX and NEPSI approvals or water-proof type	M20×1.5	1/4NPT	M8
Parts on drawings	*1	*2	*3

For double acting actuator with reversing-relay type

without pressure regulator with filter

[Unit: mm]

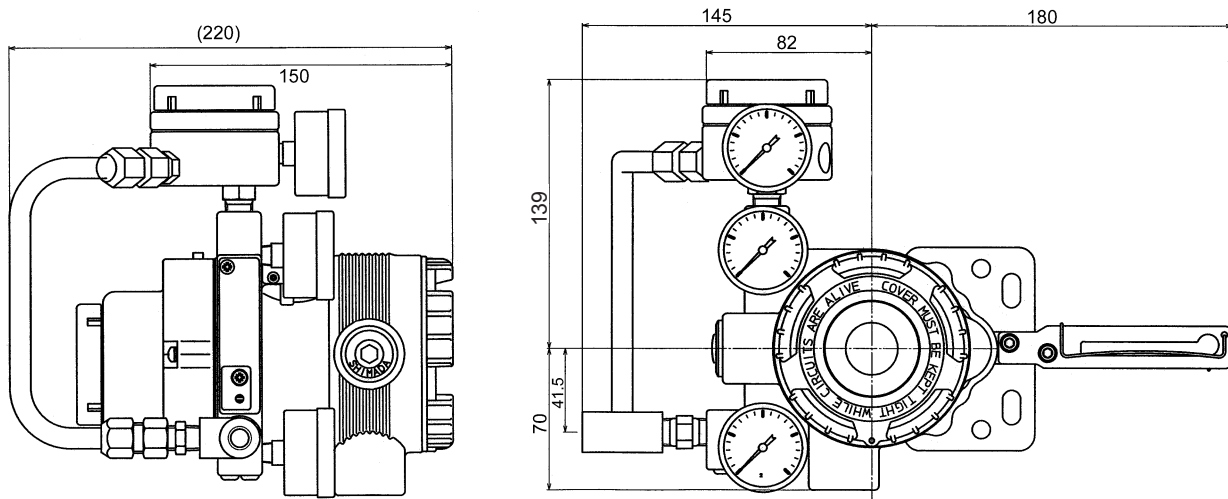

For double acting actuator with reversing relay type

with pressure regulator with filter

[Unit: mm]

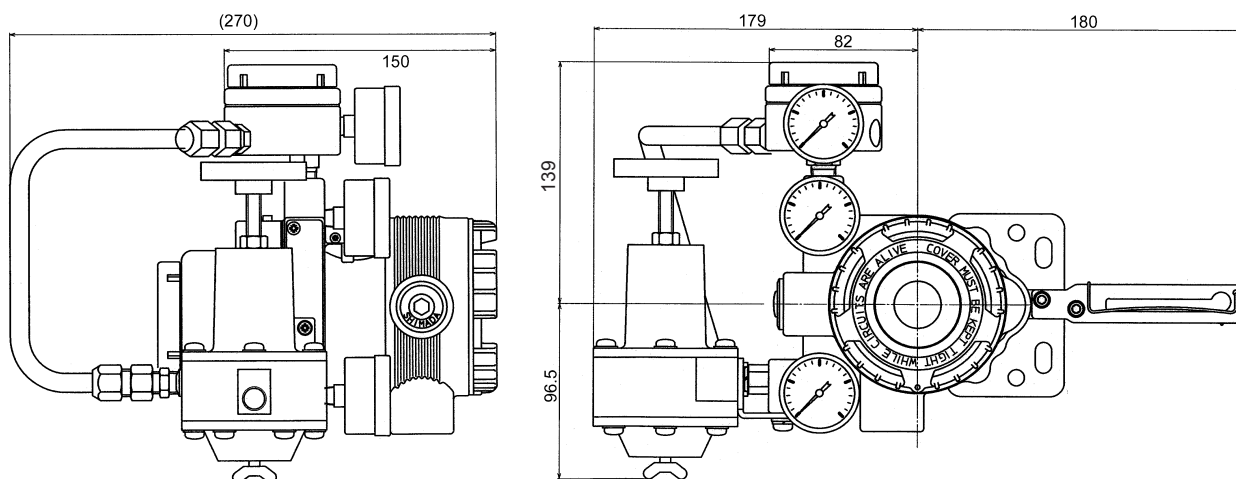

Specifications are subject to change without notice.

**azbil**

**Yamatake Corporation**  
**Advanced Automation Company**

1-12-2 Kawana, Fujisawa-shi  
 Kanagawa-ken 251-8522 Japan

URL:<http://www.azbil.com>

No part of this publication may be reproduced or duplicated without the prior written permission of Yamatake Corporation.

Dec. 1999-Y/Y  
 Jun. 2009 (rev.11)-Y/Y