

# SVP3000 Alphaplus

## Smart Valve Positioner

### Models AVP300 and AVP301

#### OVERVIEW

SVP3000 Alphaplus models AVP300 and AVP301 are current-pneumatic smart valve positioners.

The SVP3000 Alphaplus receives a DC current signal from control devices and controls pneumatic valves. In addition to this basic function, the SVP3000 Alphaplus has communication capabilities, automatic configuration program, and self diagnostics functions that will greatly increase productivity and the efficiency of plant operation.

The model AVP301 has a valve travel transmitter function which transmits a 4-20 mA DC signal.

#### FEATURES

##### **Easy to use**

###### • **Auto setup**

The auto-setup function is a fully-automatic configuration program which specifies the actuator and adjusts the zero and span of the valve. The program can be turned on simply from an external switch so that adjustments to the valve can be performed quickly and safely in hazardous areas.

##### **High reliability**

###### • **Positive seating**

The positive seating function completely shuts off the valve if the input signal becomes lower than previously set. This in turn enhances the full shut-off capabilities of the valves.

###### • **Self-diagnostic**

The self-diagnostic function provides with the ability to check the status of the positioner at any time and to alert in case of failure.

##### **Single model for multiple specifications**

SVP Alphaplus' settings can be changed without replacing any parts. A single model can be modified to suit any application.



###### • **Input range:**

Configurable to any required range for split range

###### • **Flow characteristic:**

Linear, EQ%, Quick opening or custom user characteristics

###### • **Actuator type:**

Single or double acting actuator (optional reversing relay required)

##### **Travel transmission**

The model AVP301 transmits a 4-20 mA signal proportional to the valve travel. The valve travel can be monitored from the control room.

##### **China RoHS**

This device is used in the Oil & Gas, Petrochemical, Chemical, Pulp & Paper, Food & Beverage, Machinery, Steel/Metal & Mining, and Automobile industries and therefore does not fall under the China RoHS Legislation. If this device is used in semiconductor manufacturing equipment, labeling on the device and documents for the China RoHS may be required. If such documents are required, consult a Yamatake representative.

**FUNCTIONAL SPECIFICATIONS****Applicable actuator**

Single and double acting actuator  
Linear and rotary motion actuator

**Approvals****TIIS Flameproof approval**

Ex d IIC T6 Certificate No. TC16388

**KOSHA Flameproof approval**

Ex d IIC T6

**FM Explosionproof approval**

**Explosionproof** for Class I, Division 1, Group A, B, C, D

**Dust-ignition** for Class II, Division 1, Group E, F, G

**Suitable** for Class III, Division 1

**Flameproof** for Class I, Zone 1, AEx d IIC T6 at Ambient temperature < 80°C

Installation should comply with NEC.

**FM Intrinsically safe approval**

**Intrinsically safe** for Class I, II, III, Division 1, Group A, B, C, D, E, F, G, T4

**Intrinsically safe** for Class I, Zone 0, AEx ia IIC T4, Ta=80°C

**Nonincendive** for Class I, Division 2, Group A, B, C, D, T5, Ta=80°C

**Suitable** for Class II, Division 2, Group F, G, T4, Ta=80°C

The barriers should be FM recognized types and comply with the following conditions as follows.

Input signal line:  $12.02 \leq V_{max} \leq 30V$ ,  $I_{max}=100mA$ ,  
 $P_{max}=1W$ ,  $C_i=0\mu F$ ,  $L_i=0.22mH$

For travel transmission line:  $V_{max}=30V$ ,  
 $I_{max}=100mA$ ,  $P_{max}=1W$ ,  
 $C_i=0.07\mu F$ ,  $L_i=0.22mH$

Installation should comply with NEC.

**ISSEP/ATEX Flameproof approval**

II 2 G EEx d IIC T6 at  $-20^{\circ}C \leq T_{amb} \leq +70^{\circ}C$

IEC IP66

Certificate No. ISSeP 02ATEX056

Flameproof cable gland must be ATEX approved.

**KEMA/ATEX Intrinsically safe approval**

II 1 G Ex ia IIC T4

II 1 D Ex iaD 20 IP66 T135°C

Certificate No. KEMA 00ATEX1111 X

IEC IP66

The barriers should be ATEX certified types and comply with the following condition as follows.

Input circuit (terminals  $\pm IIN$ )

$U_i = 30 V$ ,  $I_i = 100 mA$  (resistively limited),

$P_i = 1 W$ ,  $C_i = 1 nF$ ,  $L_i = 0.2 mH$

Output circuit (terminals  $\pm IOUT$ )

$U_i = 30 V$ ,  $I_i = 100mA$  (resistively limited),

$P_i = 1 W$ ,  $C_i = 3 nF$ ,  $L_i = 0.2 mH$

Both circuits shall be considered to be connected to ground from a safety point of view.

**CSA Explosionproof approval**

**Explosionproof** for Class I, Division 1, Group B, C, and D

**Flameproof** for Class I, zone 1, Ex d IIC, T6

**Dust ignition proof** for Class II and III Division 1, Group E, F and G Type 4X,

Certificate No. 188352-1028066 (LR113752-6)

**NEPSI Flameproof approval**

Ex d IIC T6, with NEPSI Dust ignition DIP A20 Ta T6  
Flameproof cable gland must be NEPSI approved.

**NEPSI Intrinsically safe approval**

Ex ia IIC T4-T6

The barriers should be NEPSI certified types and comply with the following condition as follows.

Input circuit (terminals  $\pm IIN$ )

$U_i = 30 V$ ,  $I_i = 95 mA$

$P_i = 0.66 W$ ,  $C_i = 0\mu F$

$L_i = 0.2 mH$

Output circuit (terminals  $\pm IOUT$ )

$U_i = 30 V$ ,  $I_i = 95 mA$

$P_i = 0.66 W$ ,  $C_i = 0\mu F$

$L_i = 0.2 mH$

**Combination of NEPSI Flameproof and Intrinsically safe**

When used as NEPSI Flameproof, it complies NEPSI Flameproof approval as above,

When used as NEPSI Intrinsically safe, it complies NEPSI Intrinsically safe approval as above.

**Control signal input**

4-20 mA DC (Configurable any required range for split range, minimum span: 4 mA DC), minimum driving current: 3.85 mA.

In case of model AVP301 when signal input is less than 3.85 mA, output current will be burnout.

**Input resistance**

300  $\Omega$  max. / 20 mA DC

**Output characteristics**

- Linear, Equal percentage, Quick opening
- Custom Configurable- 15 segments

**Stem travel range**

Feedback Lever Angle  $\pm 4^{\circ}$  to  $\pm 20^{\circ}$

**Bypass operation**

Auto/Manual external switch (For single acting type only)

**Air supply pressure**

140 to 700 kPa {1.4 to 7.0 kgf/cm<sup>2</sup>}

**Air consumption**

4 l/min(N) maximum at 140 kPa {1.4 kgf/cm<sup>2</sup>}

5 l/min(N) maximum at 280 kPa {2.8 kgf/cm<sup>2</sup>}

6 l/min(N) maximum at 500 kPa {5.0 kgf/cm<sup>2</sup>}

10 l/min(N) maximum at 400 k Pa {4.0 kgf/cm<sup>2</sup>}

for double acting type

**Maximum air deliver flowrate**110 l/min(N) at 140 kPa {1.4 kgf/cm<sup>2</sup>}250 l/min(N) at 400 kPa {4.0 kgf/cm<sup>2</sup>}

for double acting type

**Output balanced pressure**

55 ± 5% for double acting type only

**Lightning protection**

Peak value of voltage surge: 12 kV

Peak value of current surge: 1000A

**Vibration tolerance**

2G (5 to 400 Hz)

(with standard mounting kit on Yamatake HA actuator)

**Ambient temperature limits**

-40°C to 80°C for general model

TIIS Flameproof	:	-20°C to 55°C
KOSHA Flameproof	:	-20°C to 55°C
FM Explosionproof	:	-40°C to 80°C
FM Intrinsically safe	:	-40°C to 80°C
ISSeP/ATEX Flameproof	:	-20°C to 70°C
KEMA/ATEX Intrinsically safe:	:	-40°C to 60°C
CSA Explosionproof	:	-40°C to 80°C
NEPSI Flameproof	:	-40°C to 60°C
NEPSI Intrinsically safe	:	
For Ex ia IIC T6	:	-40°C to 40°C
For Ex ia IIC T5	:	-40°C to 60°C
For Ex ia IIC T4	:	-40°C to 80°C

**Ambient humidity limits**

10% to 90% RH

**CE conformity****Electromagnetic compatibility**

EN61326-1: 2006 (CE Marking)

**Configuration tools**

- Model CFN100 (CommPad Smart Communicator)
- Model SFC160 or SFC260 (SFC Smart Field Communicator, Software version 7.8 or later)

**PERFORMANCE SPECIFICATIONS****Accuracy**

For 8 mA ≤ input signal span &lt; 16 mA

± 1% F.S. (± 2.5% with custom output characteristics)

For 4 mA ≤ input signal span &lt; 8 mA

± 1.5% F.S.

**Travel transmission accuracy**

± 1% F.S. (±2.5% with output characteristics modification)

**PHYSICAL SPECIFICATIONS****Enclosure classification**

JIS C0920 watertight, NEMA type 4X, IP66

**Finish**

Baked acrylic

**Color**

Dark blue

**Material**

Cast aluminum

**Weight****For single acting type**

Without Pressure regulator with filter : 2.5 kg

With Pressure regulator with filter : 3.2 kg

**For double acting type**

Without Pressure regulator with filter : 2.8 kg

With Pressure regulator with filter : 3.5 kg

**INSTALLATION****Air connections**

Rc1/4 or 1/4NPT internal thread

**Electrical connections**

G1/2, 1/2NPT or M20×1.5

For travel transmission, additional wiring for the power supply is required.

**Conditions of supply air (JIS C1805-1 (2006))****Particles**

Maximum diameter 3 μm

**Oil mist**

Less than 1 ppm at mass

**Humidity of the air supply**

The dew point should be at least 10°C lower than the temperature of this device.

**Typical installation**

Figure 1 shows wiring for the model AVP300 (Smart positioner without travel transmission). In this case, you can connect a SVP to its terminal for communications.

Figure 2 shows wiring for the model AVP301 (Smart positioner with travel transmission). In this case, you can connect a SVP anywhere along the travel transmission wiring for communications.

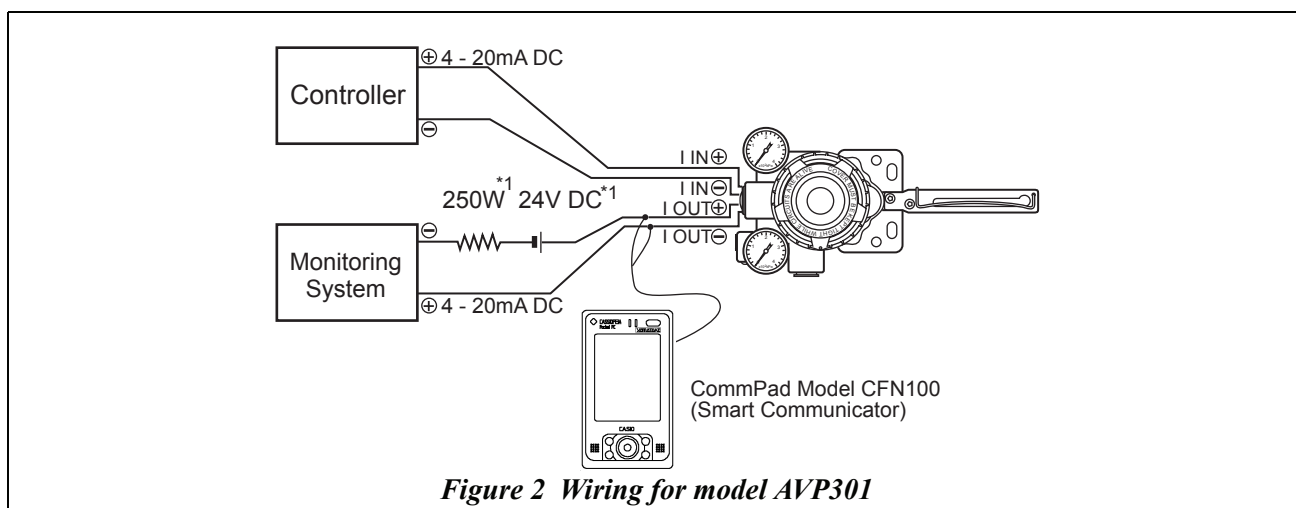
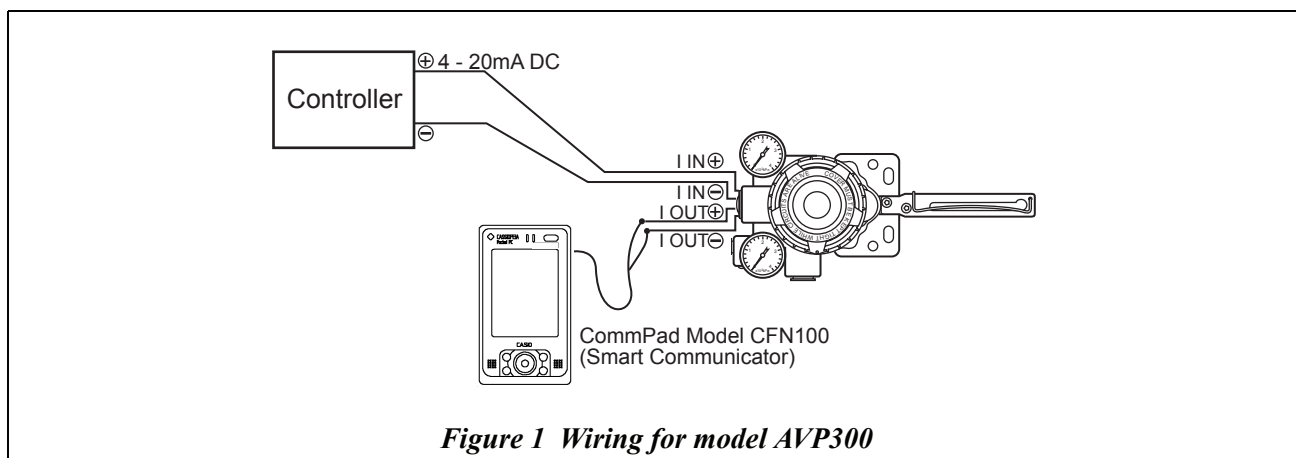

Note) \*1: For load resistance, refer to Figure 3.

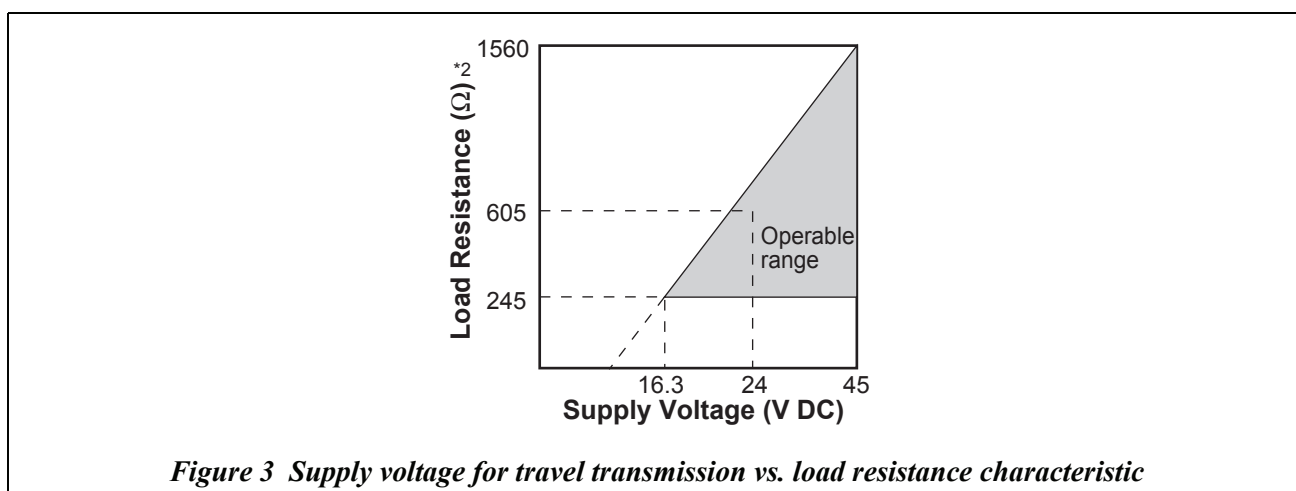

Note) Supply voltage shall be limited to 45 V DC

\*2. Load resistance = Resistance for Monitoring system + 250Ω\*1 + Resistance of supply voltage\*1

## MODEL SELECTION

Basic model no.

AVP300	-	(1)	(2)	(3)	(4)	(5)	-	(6)	(7)	(8)	(9)	-	(10)
--------	---	-----	-----	-----	-----	-----	---	-----	-----	-----	-----	---	------

Analog signal (4 to 20 mA DC) without travel transmission.

AVP301	-	(1)	(2)	(3)	(4)	(5)	-	(6)	(7)	(8)	(9)	-	(10)
--------	---	-----	-----	-----	-----	-----	---	-----	-----	-----	-----	---	------

Analog signal (4 to 20 mA DC) with travel transmission.

- Note) \*1 1 set of TIS Flameproof cable gland shall be attached for model AVP300. Two sets are for model AVP301.  
 \*2 Standard finish is equal to previous Y138A. Corrosion proof is equal to previous Y138B.  
 \*3 No domestic sales in Japan due to Non-SI unit.  
 \*4 For TIS Flameproof model, these elbows should be put on the supplied cable gland. Code "A" and "C" can not be selected simultaneously.  
 \*5 Code "E" and "N" can not be selected simultaneously.  
 \*6 Code "F" and "G" can not be selected simultaneously.  
 \*7 Select model AVP (integral type) only when the direction of drain of the pressure regulator with filter on the control valve is downward (ground).

	Connection	Air piping	Electrical connection	Mounting thread	Code
(1) Structure	Water-proof	Rc1/4	G1/2	M8	X
	Water-proof	1/4NPT internal	1/2NPT internal	5/16-18	P
	Water-proof	1/4NPT internal	M20 × 1.5	M8	Q
	TIS Flameproof with cable gland *1	Rc1/4	G1/2	M8	E
	KOSHA Flameproof	Rc1/4	G1/2	M8	S
	FM Explosionproof and Flameproof	1/4NPT internal	1/2NPT internal	5/16-18	F
	FM Intrinsically safe	1/4NPT internal	1/2NPT internal	5/16-18	M
	CSA Exprosnproof	1/4NPT internal	1/2NPT internal	5/16-18	A
	ISSEP/ATEX Flameproof	1/4NPT internal	M20 × 1.5	M8	C
	KEMA/ATEX Intrinsically safe	1/4NPT internal	M20 × 1.5	M8	L
	NEPSI Flameproof	1/4NPT internal	1/2NPT internal	5/16-18	B
	NEPSI Flameproof	1/4NPT internal	M20 × 1.5	M8	N
	NEPSI Intrinsically safe and Flameproof	1/4NPT internal	1/2NPT internal	5/16-18	R
NEPSI Intrinsically safe and Flameproof	1/4NPT internal	M20 × 1.5	M8	W	
(2) Finish	Standard (Baked acrylic) *2				S
	Corrosion proof (Baked epoxy) *2				B
	Silver finish (Baked acrylic)				D
(3) Positioner action	Direct action - Air pressure increases with control signal increase				D
	Reverse action - Air pressure decreases with control signal increase				R
(4) Supply air pressure classification	Air supply range		Pressure gauge scale	Max. regulator setting	
	130<Ps≤150 kPa {1.3<Ps≤1.5 kgf/cm <sup>2</sup> }		200 kPa {2 kgf/cm <sup>2</sup> }	400 kPa {4 kgf/cm <sup>2</sup> }	1
	150<Ps≤300 kPa {1.5<Ps≤3.0 kgf/cm <sup>2</sup> }		400 kPa {4 kgf/cm <sup>2</sup> }	400 kPa {4 kgf/cm <sup>2</sup> }	2
	300<Ps≤400 kPa {3.0<Ps≤4.0 kgf/cm <sup>2</sup> }		600 kPa {6 kgf/cm <sup>2</sup> }	400 kPa {4 kgf/cm <sup>2</sup> }	3
	400<Ps≤450 kPa {4.0<Ps≤4.50 kgf/cm <sup>2</sup> }		600 kPa {6 kgf/cm <sup>2</sup> }	700 kPa {7 kgf/cm <sup>2</sup> }	4
(5) Scale unit (Pressure gauge)	kPa				A
	kgf/cm <sup>2</sup> *3				B
	MPa				C
	bar				D
	psi *3				E
(6) Pressure regulator with filter	No selection				X
	Model KZ03 pressure regulator with filter (mounted on positioner) *7				1
	Model KZ03 pressure regulator with filter (with bracket for separated mount)				2
(7) Material of Bracket / Bolts	No selection				X
	Stainless steel / Stainless steel				D
(8)(9) Actuators (for bracket)	No selection				XX
	For single acting actuator				Refer to Table 1
	For double acting actuator				Refer to Table 2
(10) Option (Plural selection available)	No selection				X
	Universal elbow explosion-proof (SUS304 G1/2) 1 pc. for model AVP300 *4				A
	Universal elbow explosion-proof (SUS304 G1/2) 2 pcs. for model AVP301 *4				C
	Stainless filter for KZ03 (Pressure regulator with filter)				K
	2 pcs. of adapter for air piping connection (Rc1/4 to 1/4NPT) for single acting actuator *5				E
	3 pcs. of adapter for air piping connection (Rc1/4 to 1/4NPT) for double acting actuator *5				N
	1 pc. of adapter for electric connection (G1/2 to 1/2NPT) for model AVP300 *6				F
	2 pcs. of adapter for electric connection (G1/2 to 1/2NPT) for model AVP301 *6				G
	Filter (Screen for air-exhaust port)				H
	Reversing relay for double acting actuator				W
Seal tape prohibited				J	

Configuration Following shows default and optional settings of each configurable parameter of SVP.

Unless otherwise specified, the Smart Valve Positioner will be shipped in the following configuration.

- |  |                          |  |
|--|--------------------------|--|
| 1. Input control signal                    | 4 to 20 mA               | The minimal span for custom range = 4 mA               |
| 2. Output characteristic                   | Liner                    | EQ or QO can be ordered or set by user.                |
| 3. Valve action                            | Direct (Plug above seat) | Reverse (Plug below seat) can be ordered or set by use |
| 4. Output signal for position transmission | 4 to 20 mA               | DE also selectable                                     |

Table 1 Mounting bracket for single acting actuator

(8)(9) Mounting bracket for pneumatic actuators	Code
PSA1, PSA2, PSK1	YS
PSA3, PSA4 / VA1 to VA3 produced after Apr.'83 *1	YQ
PSA3, PSA4 for existing valves produced on/ before 1999	YY
PSA6 / VA4 to VA6 produced after Apr.'83 *1	YL
PSA7	Y8
HA1	YA
HA2, HA3, HL2, HL3	YT
HA4, HL4	YN
HK1, VM1 *12	YK
VM12 for model VSP *4	YB
VR1	YV
VR2, VR3	YR
VR3H	Y6
RSA1	YF
RSA2	YU
GOM 83S, GOM 84S, GOM 103S	YG
GOM 124S	YM
VA1 - VA3 (for old-model motion connectors) Produced on/before Apr.'83 800-1, 800-3 *2	YW
VA4 - VA5 (for old-model motion connectors) Produced on/before Apr.'83 800-4, 800-5 *2	YJ
Motoyama Mfg. 2800 series 240, 280, 330, Nihon Koso A100 series 270, 320 *3	TA
Motoyama Mfg. 2800 series 400, 500S, 500L, Nihon Koso A100 series 400, 500 *3	TB
Motoyama Mfg. 2800 series 650S, 650L	TC
Motoyama Mfg. 2800 series 240, 280, 330 (with side manual)	TD
Motoyama Mfg. 2800 series 400, 500S, 500L (with side manual)	TE
Motoyama Mfg. 2800 series 650S, 650L (with side manual)	TF
Motoyama Mfg. 3800 series (multi-spring type) N24, N28, N33S	TJ
Motoyama Mfg. 2922 series (Gyrol-I) G.R.I 280H, 330H, 400HS, 400H, 500H	TL
Motoyama Mfg. 3993 series (Gyrol-II) 2911-1M series 280, 330, 400	TG
Nihon Koso 5100L series 240, 280 *3	TP
Nihon Koso 5200L series 218, 270, 350 *3	TR
Masoneilan 37, 38 series #9, #11 *3	MA
Masoneilan 37, 38 series #13 *3	MB
Masoneilan 37, 38 series #15, #18 *3	MC

Table 1 Mounting bracket for single acting actuator

(8)(9) Mounting bracket for pneumatic actuators	Code
Masoneilan 37, 38 series #15, #18 (with side manual)	MF
Masoneilan type 35002 series Camflex II #41/2, #6, (Valve size 1 inch - 4 inches)	MG
Masoneilan type 35002 Camflex II #7 (Valve size 6 inches - 12 inches)	MH
Fisher 657, 667 series size 40	FB
Fisher 657, 667 series size 45, 50	FC
Fisher 657, 667 series size 60	FD
Tyco Flow Control Japan AK09S, AK12S, AK15S	KA
Tyco Flow Control Japan AG06S, AGN06S	KG
Tyco Flow Control Japan AG09S, AGN09S	KH
Tyco Flow Control Japan AG13S, AGN13S	KJ
Tyco Flow Control Japan AW13S	KV
Tyco Flow Control Japan AW17S	KW
Tyco Flow Control Japan AW20S	KT
KITZ B series BS-2, BSW-2	B2
KITZ B series BS-3, BSW-3, Hisaka TS-6	B3
KITZ B series BS-4, BSW-4	B4
KITZ B series BS-5, BSW-5	B5
KITZ B series BS-6, BSW-6	B6
Xomox (EL-O-MATIC) E25, 40, 65, 100, 200, 350	RA
Xomox (EL-O-MATIC) E600, 950, 1600, P2500, P4000	RB
Hisaka TS-1	H1
Hisaka TS-2	H2
Hisaka TS-3	H3
Hisaka TS-4, 5	H4
Tomoe Valve Z series Z-06S, 08S, 11S, 13S	EA
Tomoe Valve T-matic 3Q-1, 2, 3, 4	E3

- Note) \*1 Select "YW" or "YJ" for old-type motion connectors. (Produced on/before Apr.'83)
- \*2 Consult with sales representative in case of no mounting hole on the side of valve yoke.
- \*3 Select in the case of without manual handle or with manual handle mounted on top of the actuators.
- \*4 Additional support bracket is required.
- \*12 In case "VM" type actuator is required following conditions, 1. select model "VCT" for the body, 2. the existing positioner should be HEP or VPE, 3. yoke should be model HK. If another spec. is required, contact your sales representative.

Table 2 Mounting bracket for double acting actuator

(8)(9) Mounting bracket for pneumatic actuators		Code
VP5, 6	*1	Y1
VP7	*1	Y7
SLOP560, 1000, 1000X	*1 *2	Y2
SLOP1500, 1500X	*1 *2	Y3
DAP560, 1000, 1000X	*1 *2	Y4
DAP1500, 1500X	*1 *2	Y5
Tyco Flow Control Japan AK09, AK12, AK15	*1	KA
Tyco Flow Control Japan AG06, AGN06	*1	KG
Tyco Flow Control Japan AG09, AGN09	*1	KH
Tyco Flow Control Japan AG13, AGN13	*1	KJ
Tyco Flow Control Japan AW13	*1	KV
Tyco Flow Control Japan AW17	*1	KW
Tyco Flow Control Japan AW20	*1	KT
KITZ B series B-2	*1	B2
KITZ B series B-3	*1	B3
KITZ B series B-4	*1	B4
KITZ B series B-5	*1	B5
KITZ B series B-6	*1	B6
Xomox (EL-O-MATIC) E25, 40, 65, 100, 200, 350	*1	RA
Xomox (EL-O-MATIC) E600, 950, 1600, P2500, P4000	*1	RB
Tomoe Valve Z series Z-06, 08, 11, 13	*1	EA
Tomoe Valve T-matic 3I-1, 2, 3, 4	*1	E3
T. V. VALVE AT4-80	*1	V1
T. V. VALVE AT4-100	*1	V2
T. V. VALVE AT4-120	*1	V3
T. V. VALVE AT4-150	*1	V4
T. V. VALVE AT4-180	*1	V5

Note) \*1 In case of double acting actuator, a reversing relay unit required.

\*2 Contact a sales representative if a bracket for model VFR (FloWing) or butterfly valve is required.

Table 3 Standard travel range and accuracy

Actuator	Travel (mm)	Accuracy [% F.S.]
PSA1, 2	14.3, 20, 25	1
PSA3, 4	20, 38	1
HA1	6, 8, 10	3
	14.3, 25	1
HA2	10	3
	14.3, 25, 38	1
HA3	14.3	3
	25, 38, 50	1
HA4	14.3	3
	25, 38, 50, 75	1
VA5	25, 37.5, 50, 75, 100	1
VA6	14.3	3
PSA6, 7	25, 37.5, 50, 75, 100	1
HK1	10	3
PSK1	19	1



For single acting actuator with pressure regulator with filter

[Unit: mm]

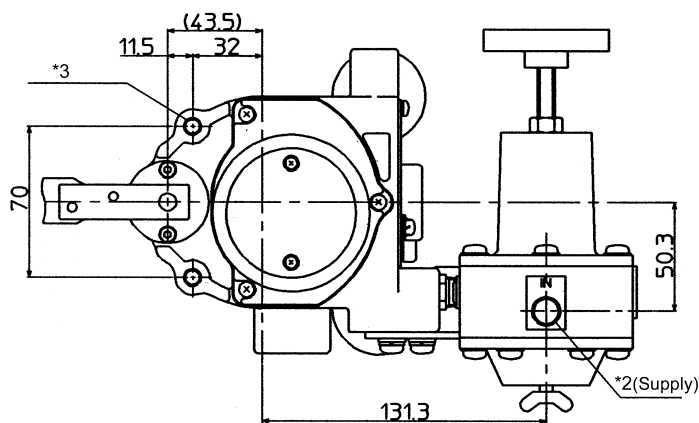
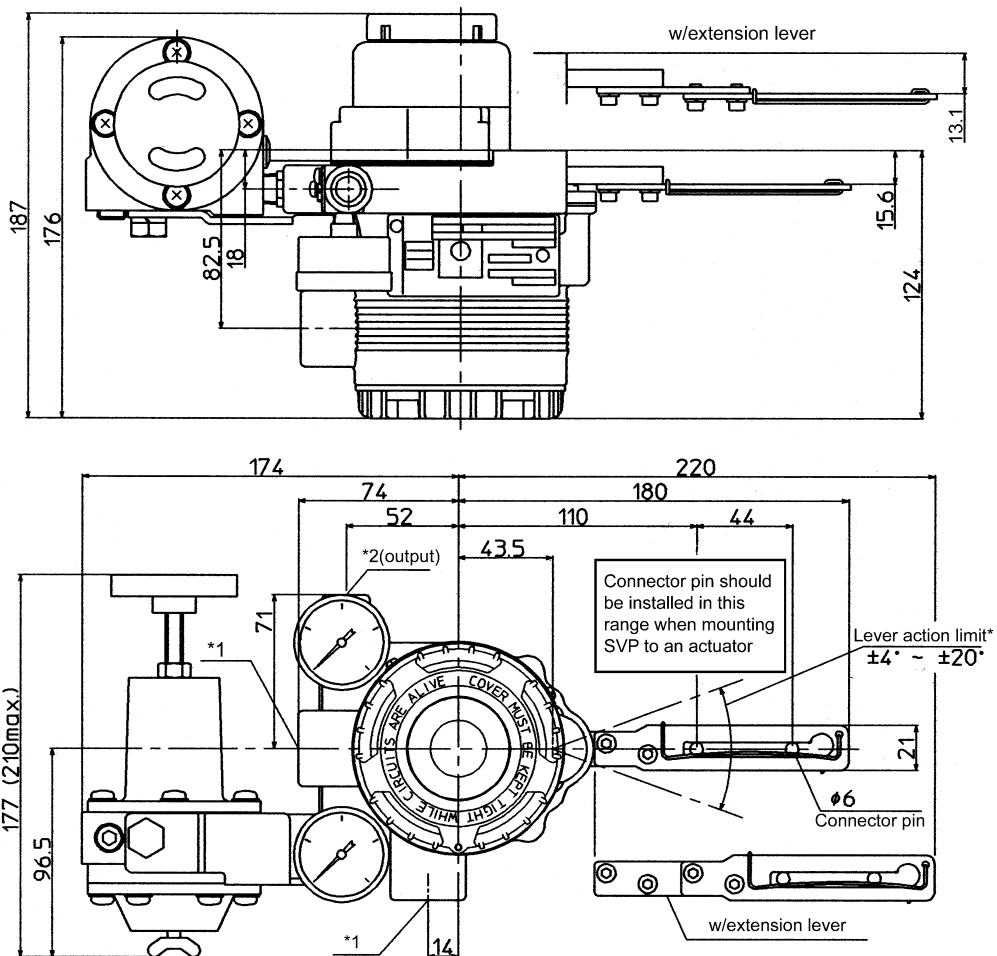

Extension lever	Actuator model	Code
No	PSA1, 2, PSK1	YS
	HA1	YA
	HA2, 3	YT
	HK1	YK
Yes	PSA3, 4	YQ
	VA1 to 3	YQ
	PSA6	YL
	PSA7	Y8
	HA4	YN
	VA4 to 6	YL
	VR1	YV
	VR2, 3	YR
	GOM83S, 84S, 103S	YG
	GOM124S	YM

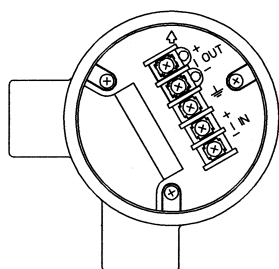

Types	Electrical connection	Air piping connection	Mounting threads
TIIS and KOSHA Flameproof or water-proof type	G1/2	Rc1/4	M8
FM and CSA approvals, NEPSI approvals or water-proof type	1/2NPT	1/4NPT	5/16-18UNC
ISSep/ATEX Flameproof, KEMA/ATEX intrinsically safe, NEPSI approvals or water-proof type	M20×1.5	1/4NPT	M8
Parts on drawings	*1	*2	*3

For double acting actuator with reversing-relay

Without pressure regulator with filter

[Unit: mm]

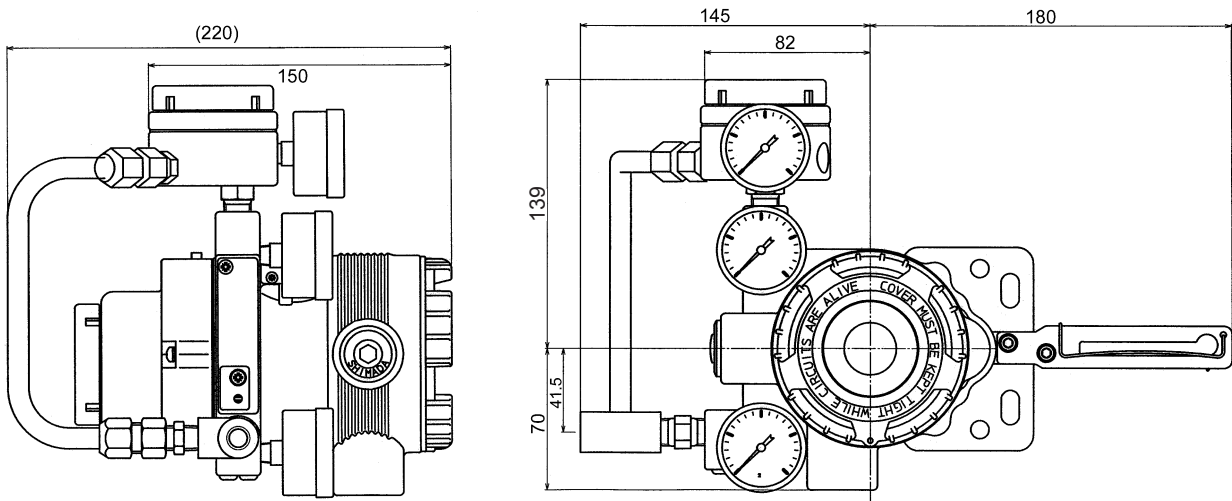

With pressure regulator with filter

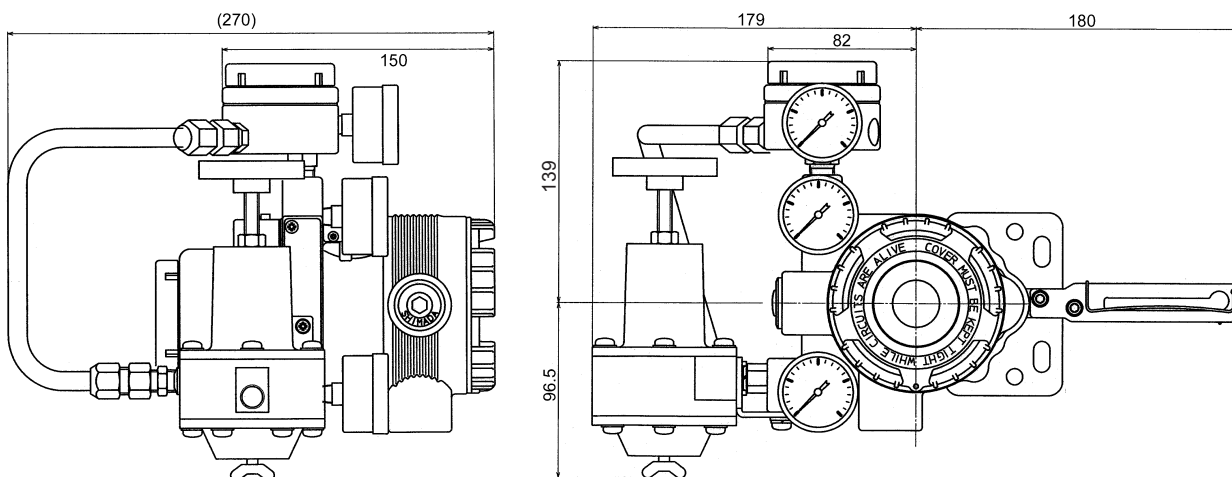



*Specifications are subject to change without notice.*

**azbil**

**Yamatake Corporation**  
**Advanced Automation Company**

1-12-2 Kawana, Fujisawa-shi  
Kanagawa-ken 251-8522 Japan

**URL:**<http://www.azbil.com>

*No part of this publication may be reproduced or duplicated without the prior written permission of Yamatake Corporation.*

Apr. 1998–Y/Y  
Aug. 2011 (rev.17)–Y/Y