

SVP3000 Alphaplus

Smart Valve Positioner (Remote type) with HART Communication Protocol

Model AVP202

OVERVIEW

SVP3000 Alphaplus model AVP202 is a current-pneumatic smart valve positioner with a separate valve travel detector. The valve detector and positioner are interconnected with a dedicated cable. By installing only its valve detector onto the valve body, it will drastically make positioner maintenance easier as well as improving anti-vibration characteristics.

Calibration, configuration and self-diagnostics can be performed by using a HART communicator

FEATURES

Anti-vibration characteristics 10G, 2000 Hz

Vibration resistance has been improved so that it is five times more durable which conventional current-pneumatic positioners.

It is suitable for valves that are located in an environment with strong vibration, which previously could use only pneumatic positioners.

Valve diagnostic (software version 3.D or newer)

Following parameters can be monitored by HART communicator or Control Valve Maintenance Support System "Valstaff".

- Stick Slip
- Total Stroke
- Travel Histogram
- Cycle Count
- Shut-Off Count
- Max. Travel Speed

Easy to use

• Auto setup

The auto-setup function is a fully-automatic configuration program which specifies the actuator and adjusts the zero and span of the valve. The program can be turned on simply from an external switch so that adjustments to the valve can be performed quickly and safely in hazardous areas.

High reliability

• Positive seating

The positive seating function completely shuts off the valve if the input signal becomes lower than previously set. This in turn enhances the full shut-off capabilities of the valves.



• Self-diagnostic

The self-diagnostic function provides with the ability to check the status of the positioner at any time and to alert in case of failure.

Single model for multiple specifications

SVP Alphaplus' settings can be changed without replacing any parts. A single model can be modified to suit any application.

• Input range:

Configurable to any required range for split range

• Flow characteristic:

Linear, EQ%, Quick opening or custom user characteristics

• Actuator type:

Single or double acting actuator (optional reversing relay required)

China RoHS

This device is used in the Oil & Gas, Petrochemical, Chemical, Pulp & Paper, Food & Beverage, Machinery, Steel/Metal & Mining, and Automobile industries and therefore does not fall under the China RoHS Legislation.

If this device is used in semiconductor manufacturing equipment, labeling on the device and documents for the China RoHS may be required. If such documents are required, consult a Yamatake representative.

FUNCTIONAL SPECIFICATIONS**Applicable actuator**

Single and double acting actuator
Linear and rotary motion actuator

Approvals**TIIS Flameproof approval**

Body: Ex d IIC T6 Approval No. TC17094
Valve travel detector: Ex d IIC T6 Approval No. TC18270

Control signal input

4-20 mA DC (Configurable to any required range for split range.)

Input resistance

400 Ω typically / 20 mA DC

Output characteristics

- Linear, Equal percentage, Quick opening
- Custom user characteristics (16 points)

Stem travel range

Feedback lever angle $\pm 4^\circ$ to $\pm 20^\circ$

Bypass operation

Auto/Manual external switch
(For single acting actuator only)

Air supply pressure

140 to 700 kPa {1.4 to 7.0 kgf/cm²}

Air consumption

4 L(N)/minutes maximum at 140 kPa {1.4 kgf/cm²}

5 L(N)/minutes maximum at 280 kPa {2.8 kgf/cm²}

6 L(N)/minutes maximum at 500 kPa {5.0 kgf/cm²}

10 L(N)/minutes maximum at 400k Pa {4.0 kgf/cm²}

for double acting actuator

Maximum air deliver flowrate

110 L(N)/minutes at 140 kPa {1.4 kgf/cm²}

250 L(N)/minutes at 400 kPa {4.0 kgf/cm²}

for double acting actuator

Output balanced pressure

55 \pm 5% for double acting actuator only

Lightning protection

Peak value of voltage surge: 12 kV
Peak value of current surge: 1000 A

Vibration tolerance**Body**

2G, 5 to 400 Hz

Valve travel detector

10G, 5 to 2000 Hz
(with standard mounting kit on Yamatake HA actuator)

Ambient temperature limits

-40°C to 80°C
TIIS Flameproof model: -20°C to 55°C

Ambient humidity limits

10% to 90% RH

Configuration tools

- Field Communication Software CommStaff Model CFS100
- HART Communicator model 375 or 475 (According to need, please update a software and device description files.)

PERFORMANCE SPECIFICATIONS**Accuracy *1**

$\pm 1\%$ F.S. ($\pm 2.5\%$ with custom output characteristics)
Depending on cable length, the accuracy varies as follows.

Cable length	Accuracy
5 m	$\pm 1.2\%$ F.S.
10 m	$\pm 1.7\%$ F.S.
20 m	$\pm 2.7\%$ F.S.

For $4\text{mA} \leq \text{input signal span} < 8\text{mA}$, $\pm 1.5\%$ F.S.

Note) *1: Refer to Table 3. Because accuracy varies depending the combination of actuator size and travel.

PHYSICAL SPECIFICATIONS**Enclosure classification**

NEMA type 4X equivalent, IP66 equivalent

Finish

Baked acrylic

Color

Dark blue

Material**Body case**

Cast aluminum

Case of valve travel detector

Stainless steel

Cable

Polyvinyl chloride for ambient temperature up to 80°C

Weight**Body**

For single acting actuator:

- Without Pressure regulator with filter : 3.3 kg
- With Pressure regulator with filter : 4.0 kg

For double acting actuator:

- Without Pressure regulator with filter : 3.6 kg
- With Pressure regulator with filter : 4.3 kg

Valve travel detector

0.9 kg

Cable

0.2 kg / 1 m Outer diameter: 9.8 mm
Sheath material: PDC (PVC)

INSTALLATION

Air connections

Rc1/4 or 1/4NPT internal thread

Electrical connections

G1/2 or 1/2NPT internal thread

Conditions of supply air (JIS C1805-1 (2006))

Particles

Maximum diameter 3 μm

Oil mist

Less than 1 ppm at mass

Humidity of the air supply

The dew point should be at least 10°C lower than the temperature of this device.

Typical installation

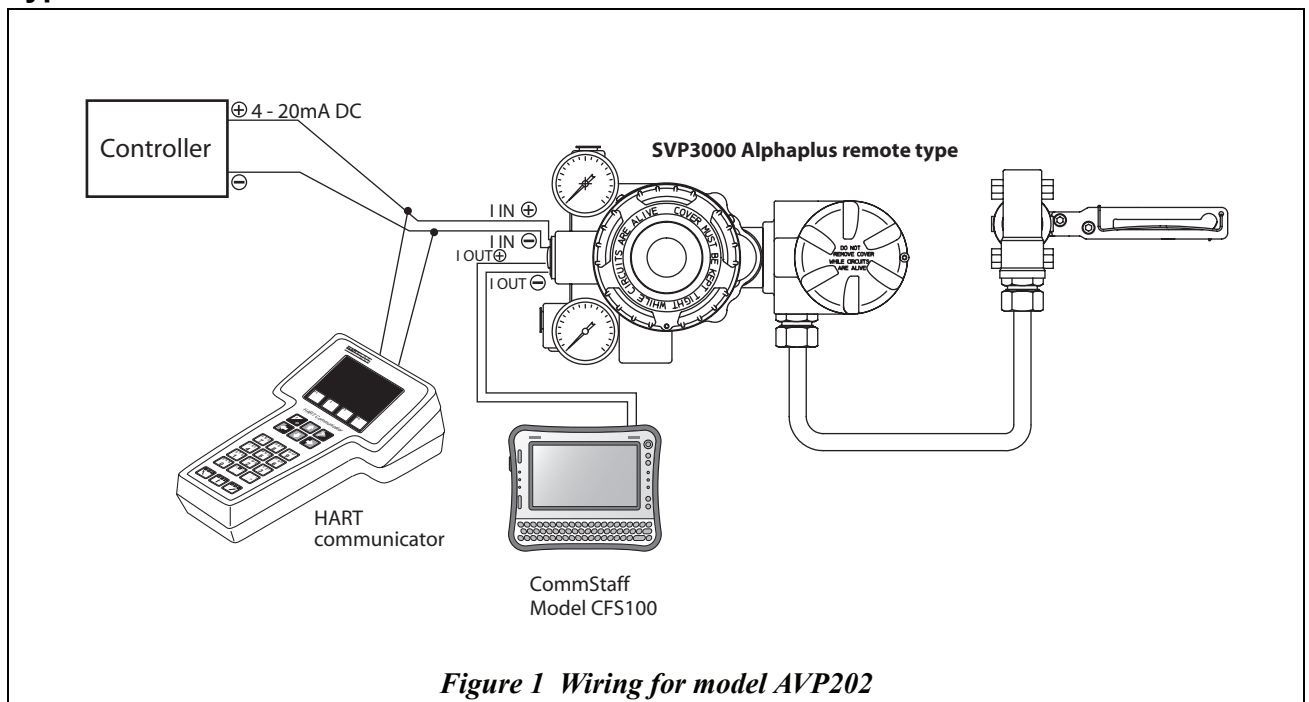

MODEL SELECTION

AVP202	(1)	(2)	(3)	(4)	(5)	-	(6)	(7)	(8)	(9)	-	(10)
--------	-----	-----	-----	-----	-----	---	-----	-----	-----	-----	---	------

Analog signal (4 to 20 mA DC) with HART communication protocol.

- Note) *1 One piece of JIS Flameproof cable gland shall be attached.
 *2 Standard finish is equal to previous Y138A. Corrosion proof is equal to previous Y138B.
 *3 No domestic sales in Japan due to Non-SI unit.
 *4 For JIS Flameproof model, this elbow is put on the supplied cable gland.
 *5 Select "YW" or "YJ" for old-type motion connectors.
 *6 Code "W" of option (10) must be selected.
 *7 Select model AVP202 only when the direction of drain of the pressure regulator with filter on the control valve is downward (ground).
 *15 Select the option with the restoration feedback lever, if GOM manufactured before April, 1988. Select the option '8' (Accessory bracket for GOM actuator - Use the case of existing GOP) if the existing control valve assembled with GOP and the accessories such as the Lock-up valves and solenoid valves.

	Air piping connection	Electrical connection	Mounting thread	Code	
(1) Structure	Water-proof	Rc1/4	G1/2	X	
	Water-proof	1/4NPT internal	1/2NPT internal	P	
	JIS Flameproof with cable gland *1	Rc1/4	G1/2	E	
(2) Finish	Standard (Baked acrylic) *2			S	
	Corrosion proof (Baked epoxy) *2			B	
	Silver finish (Baked acrylic)			D	
(3) Positioner action	Direct action - Air pressure increases with control signal increase			D	
	Reverse action - Air pressure decreases with control signal increase			R	
(4) Supply air-pressure classification	Air supply range		Pressure gauge scale	Max regulator setting	
	130<Ps≤150 kPa {1.3<Ps≤1.5 kgf/cm ² }	200 kPa {2 kgf/cm ² }	400 kPa {4 kgf/cm ² }	1	
	150<Ps≤300 kPa {1.5<Ps≤3.0 kgf/cm ² }	400 kPa {4 kgf/cm ² }	400 kPa {4 kgf/cm ² }	2	
	300<Ps≤400 kPa {3.0<Ps≤4.0 kgf/cm ² }	600 kPa {6 kgf/cm ² }	400 kPa {4 kgf/cm ² }	3	
	400<Ps≤450 kPa {4.0<Ps≤4.5 kgf/cm ² }	600 kPa {6 kgf/cm ² }	700 kPa {7 kgf/cm ² }	4	
(5) Scale unit (Pressure gauge)	450<Ps≤700 kPa {4.5<Ps≤7.0 kgf/cm ² }		1000 kPa {10 kgf/cm ² }	700 kPa {7 kgf/cm ² }	5
	kPa			A	
	kgf/cm ² *3			B	
	MPa			C	
	bar			D	
psi *3			E		

(6) Pressure regulator with filter	No selection	X
	Model KZ03 pressure regulator with filter (mounted on positioner) *7	1
(7) Cable length	3 m (For ambient temperature -40 to +80°C)	3
	5 m (For ambient temperature -40 to +80°C)	5
	10 m (For ambient temperature -40 to +80°C)	T
	20 m (For ambient temperature -40 to +80°C)	W
(8)(9) Actuators (for bracket)	No selection	XX
	For single acting actuator	Refer to Table 1
	For double acting actuator	Refer to Table 2

(10) Option	With terminal box for remote cable assembly (standard)	M
	Universal elbow explosion-proof (SUS304 G1/2) 1 pc. *4	A
	Stainless filter for model KZ03 (Pressure regulator with filter)	K
	Stainless mounting kit of a positioner side and pressure regulator with filter	U
	Reversing relay for double acting actuator	W
	Sealing tape not permitted	J
Mounting bracket for accessories on GOM actuator (in case of replacing GOP) *15	8	

Configuration Following shows default and optional settings of each configurable parameter of SVP.

- | | | |
|--------------------------|--------------------------|---|
| 1. Input control signal | 4 to 20 mA | The minimal span for custom range = 4 mA |
| 2. Output characteristic | Liner | EQ or QO can be ordered or set by user. |
| 3. Valve action | Direct (Plug above seat) | Reverse (Plug below seat) can be ordered or set |

Table 1 Mounting bracket for single acting actuator

(8)(9) Mounting bracket for pneumatic actuators	Code
PSA1, PSA2, PSK1	YS
PSA3, PSA4 / VA1 to VA3 produced after Apr.'83 *8	YQ
PSA3, PSA4 for existing valves produced on/before 1999	YY
PSA6 / VA4 to VA6 produced after Apr.'83 *8	YL
HA1	YA
HA2, HA3, HL2, HL3	YT
HA4, HL4	YN
HK1, VM1 *10 (material SS400 zinc plated)	YK
VR1	YV
VR2, VR3	YR
VR3H	Y6
RSA1	YF
RSA2	YU
GOM83S, GOM84S, GOM103S	YG
GOM124S	YM
VA1 - VA3 (for old-model motion connectors) produced on/before Apr.'83 800-1, 800-3 *9	YW
VA4, VA5 (for old-model motion connectors) produced on/before Apr.'83 800-4, 800-5 *9	YJ
Motoyama Mfg. 2800 series 240, 280, 330, Nihon Koso A100 series 270, 320 *5	TA
Motoyama Mfg. 2800 series 400, 500S, 500L, Nihon Koso A100 series 400, 500 *5	TB
Motoyama Mfg. 2800 series 650S, 650L *5	TC
Motoyama Mfg. 2800 series 240, 280, 330 (with side manual)	TD
Motoyama Mfg. 2800 series 400, 500S, 500L (with side manual)	TE
Motoyama Mfg. 2800 series 650S, 650L (with side manual)	TF
Motoyama Mfg. 3800 series (multi-spring type) N24, N28, N33S *5	TJ
Motoyama Mfg. 2922 series (Gyrol-I) G.R.I 280H, 330H, 400HS, 400H, 500H	TL
Motoyama Mfg. 3993 series (Gyrol-II) 280, 330, 400, 2911-1M series 280H, 330H, 400H	TG
Masoneilan 37, 38 series #9, #11 *5	MA
Masoneilan 37, 38 series #13 *5	MB
Masoneilan 37, 38 series #15, #18 *5	MC
Masoneilan 37, 38 series #15, #18 (with side manual)	MF
Masoneilan type 35002 series Camflex II #4-1/2, #6, #7	MG
Fisher 657, 667 series size 50	FC
Fisher 657, 667 series size 60	FD

Table 1 Mounting bracket for single acting actuator

(8)(9) Mounting bracket for pneumatic actuators	Code
Nihon Koso TC-500 series TC520S	TP
Nihon Koso TC-700 series TC-713S	TS
Nihon Koso TC-700 series TC-722SS	TT
Tyco Flow Control Japan AK05S, AK09S, AK12S, AK15S	KA
Tyco Flow Control Japan AG06S, AGN06S	KG
Tyco Flow Control Japan AG09S, AGN09S	KH
Tyco Flow Control Japan AG13S, AGN13S	KJ
Tyco Flow Control Japan AW13S	KV
Tyco Flow Control Japan AW17S	KW
Tomoe Valve Z series Z-06S, 08S, 11S, 13S	EA
Tomoe Valve T-matic 3Q-1, 2, 3, 4	E3

Note) *2 If no suitable mounting bracket can be found, contact a sales representative.

*5 Select in the case of without manual handle or with manual handle mounted on top of the actuators.

*8 Select "YW" or "YJ" for old-type motion connectors. (Produced on/before Apr.'83)

*9 Consult a sales representative in case of no mounting hole on the side of valve yoke.

*10 In case "VM" type actuator is required following conditions, 1. select model "VCT" for the body, 2. the existing positioner should be HEP or VPE, 3. yoke should be model HK. If another specification is required, contact your sales representative.

*13 For model VSP (PVC body), an additional support bracket is required for the AVP.

Table 2 Mounting bracket for double acting actuator

(8)(9) Mounting bracket for pneumatic actuators	Code
VP5, 6	*7 Y1
SLOP560, 1000, 1000X	*7 *14 Y2
SLOP1500, 1500X	*7 *14 Y3
DAP560, 1000, 1000X	*7 *14 Y4
DAP560, 1500, 1500X	*7 *14 Y5
GOM44L, 44LM (Springless horizontal)	*7 G1
GOM410L, 410LM (Springless horizontal)	*7 G2
GOM64L, 64LM (Springless horizontal)	*7 G3
GOM66L, 66LM (Springless horizontal)	*7 G4
GOM610L, 610LM (Springless horizontal)	*7 G5
GOM84L, 84LM (Springless horizontal)	*7 G6
GOM86L, 86LM (Springless horizontal)	*7 G7
GOM810L, 810LM (Springless horizontal)	*7 G8
GOM1210L, 1210LM (Springless horizontal)	*7 GT
GOM1510L, 1510LM (Springless horizontal)	*7 GU
GOM44L, 44LM (Springless horizontal) with restoration feedback lever	*7 *15 GE
GOM410L, 410LM (Springless horizontal) with restoration feedback lever	*7 *15 GF
GOM64L, 64LM (Springless horizontal) with restoration feedback lever	*7 *15 GG
GOM66L, 66LM (Springless horizontal) with restoration feedback lever	*7 *15 GH
GOM610L, 610LM (Springless horizontal) with restoration feedback lever	*7 *15 GJ
GOM84L, GOM84LM (Springless horizontal) with restoration feedback lever	*7 *15 GK
GOM86L, GOM86LM (Springless horizontal) with restoration feedback lever	*7 *15 GL
GOM810L, GOM810LM (Springless horizontal) with restoration feedback lever	*7 *15 GM
GOM1210L, GOM1210LM (Springless horizontal) with restoration feedback lever	*7 *15 GN
GOM1510L, GOM1510LM (Springless horizontal) with restoration feedback lever	*7 *15 GP
GOM84LM (Springless vertical)	*7 GB
GOM124LM (Springless vertical)	*7 GC
Nihon Koso 6300 series 63A2, AT series AT20	*7 T2
Nihon Koso 6300 series 63A3, B2, BA, B3, BB, B5, AT series AT-30, 200, 250, 300, 350, 500	*7 T3
Nihon Koso 6300 series 63A4, A5, A6, AT series AT40, AT50, AT60	*7 T4
Nihon Koso 6300 series AT series AT25	*7 T5
Nihon Koso TC-500 series TC-520W	*7 *16 TP
Nihon Koso TC-700 series TC-713W	*7 TS
Tyco Flow Control Japan AK05, AK09, AK12, AK15	*7 KA

Table 2 Mounting bracket for double acting actuator

(8)(9) Mounting bracket for pneumatic actuators	Code
Tyco Flow Control Japan AG06, AGN06	*7 KG
Tyco Flow Control Japan AG09, AGN09	*7 KH
Tyco Flow Control Japan AG13, AGN13	*7 KJ
Tyco Flow Control Japan AW13	*7 KV
Tyco Flow Control Japan AW17	*7 KW
KITZ B series BS-2, BSW-2, B-2	*7 B2
KITZ B series BS-3, BSW-3, B-3	*7 B3
KITZ B series BS-4, BSW-4, B-4	*7 B4
KITZ B series BS-5, BSW-5, B-5	*7 B5
KITZ B series BS-6, BSW-6, B-6	*7 B6
Tomoe Valve Z series Z-06, 08, 11, 13	*7 EA
Tomoe Valve T-matic 3I-1, 2, 3, 4	*7 E3
NELES BC series BC/BIC11	*7 NB

Note) *7 For the double acting actuator, a reversing relay unit is required.

*14 If the valve body is for VFR (FloWing) or a butterfly valve, for the mounting bracket requirement consult to our sales.

*15 Select the option with the restoration feedback lever, if GOM manufactured before April, 1998. Select the option '8' (Accessory bracket for GOM actuator - User the case of existing GOP) if the existing control valve assembled with GOP and the accessories such as the Lock-up valves and solenoid valves.

*16 Confirm that boss's pitch of the actuator side is 69 mm, if it is required to assemble the mounting bracket to the actuator.

Table 3 Standard travel range and accuracy

Actuator	Travel (mm)	Accuracy [% F.S.]
PSA1, 2	14.3, 20, 25	1
PSA3, 4	20, 38	1
HA1	6, 8, 10	3
	14.3, 25	1
HA2	10	3
	14.3, 25, 38	1
HA3	14.3	3
	25, 38, 50	1
HA4	14.3	3
	25, 38, 50, 75	1
VA5	25, 37.5, 50, 75, 100	1
VA6	14.3	3
PSA6, 7	25, 37.5, 50, 75, 100	1
HK1	10	3
	PSK1	19

DIMENSIONS

For single acting actuator without pressure regulator with filter

[Unit: mm]

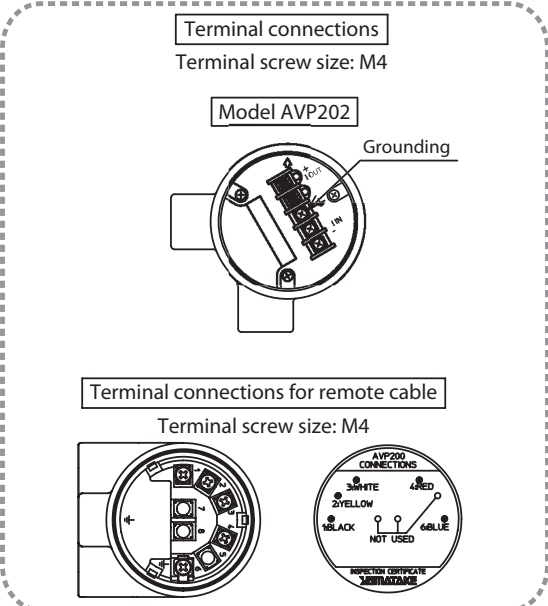
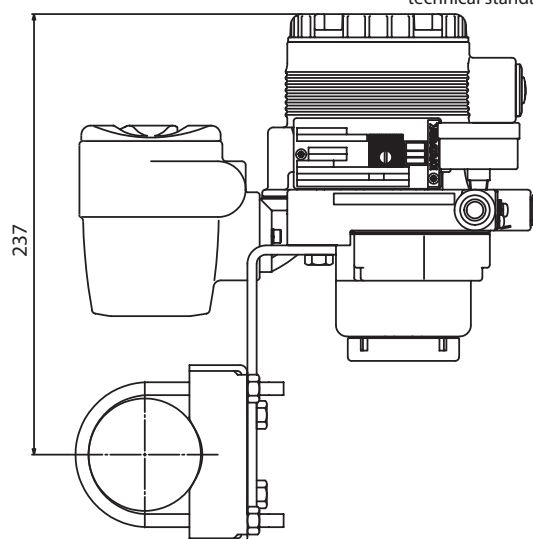
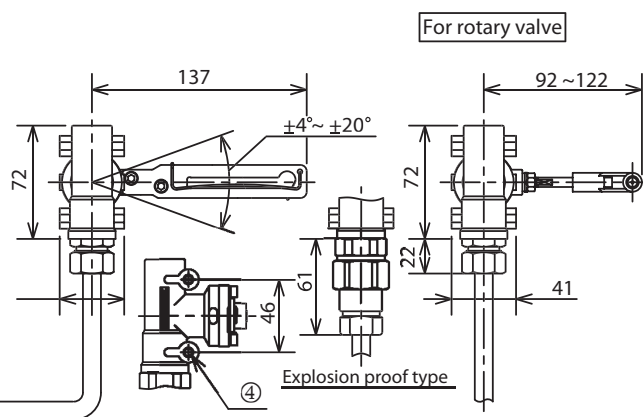
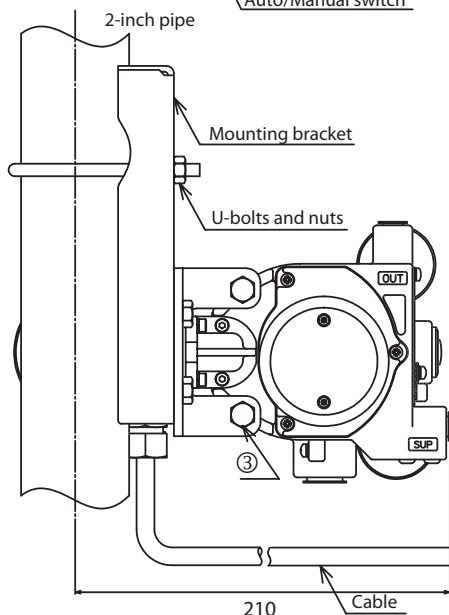
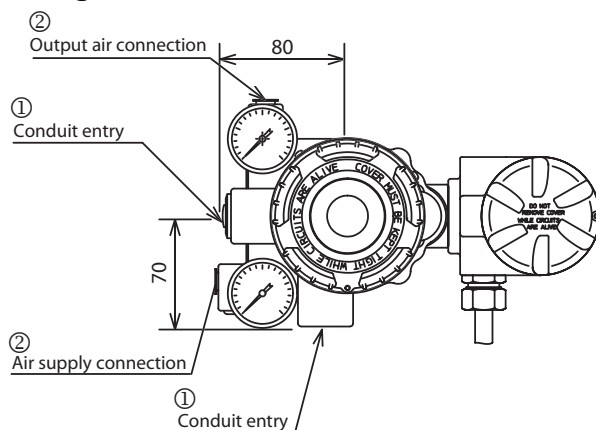
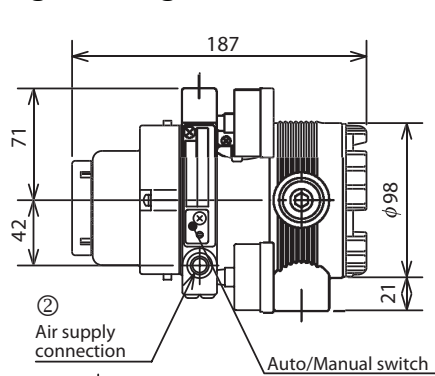

Type	Electrical connection	Air piping connection	Mounting thread	
			AVP body	Valve travel detector
Water-proof / TIS Flameproof	G1/2	Rc1/4	M8	M6
Water-proof	1/2NPT	1/4NPT	5/16-18UNC	1/4-20UNC
Parts on drawings	①	②	③	④

For single acting actuator with pressure regulator with filter

[Unit: mm]

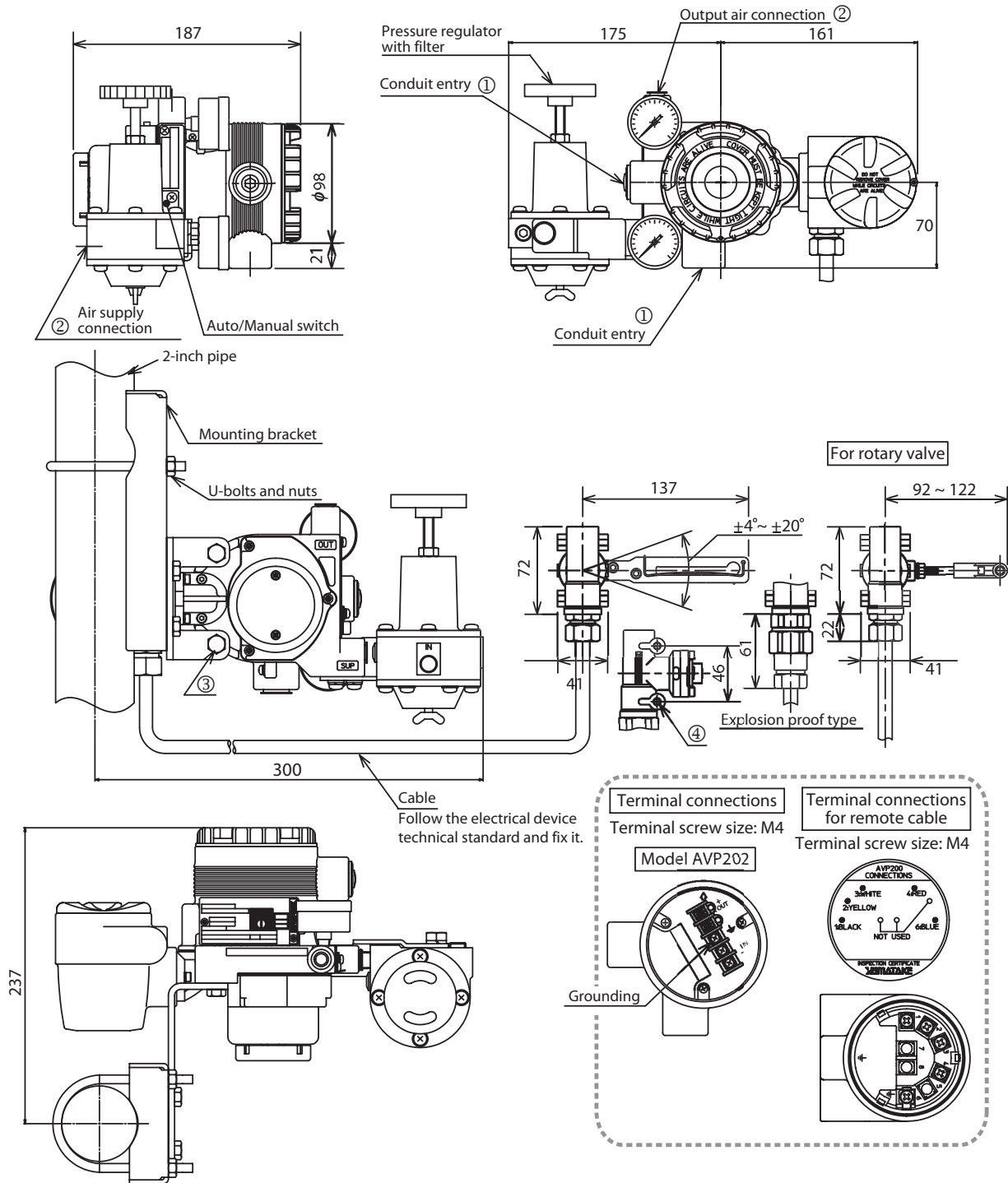

Type	Electrical connection	Air piping connection	Mounting thread	
			AVP body	Valve travel detector
Water-proof / TIS Flameproof	G1/2	Rc1/4	M8	M6
Water-proof	1/2NPT	1/4NPT	5/16-18UNC	1/4-20UNC
Parts on drawings	①	②	③	④

For double acting actuator without pressure regulator with filter

[Unit: mm]

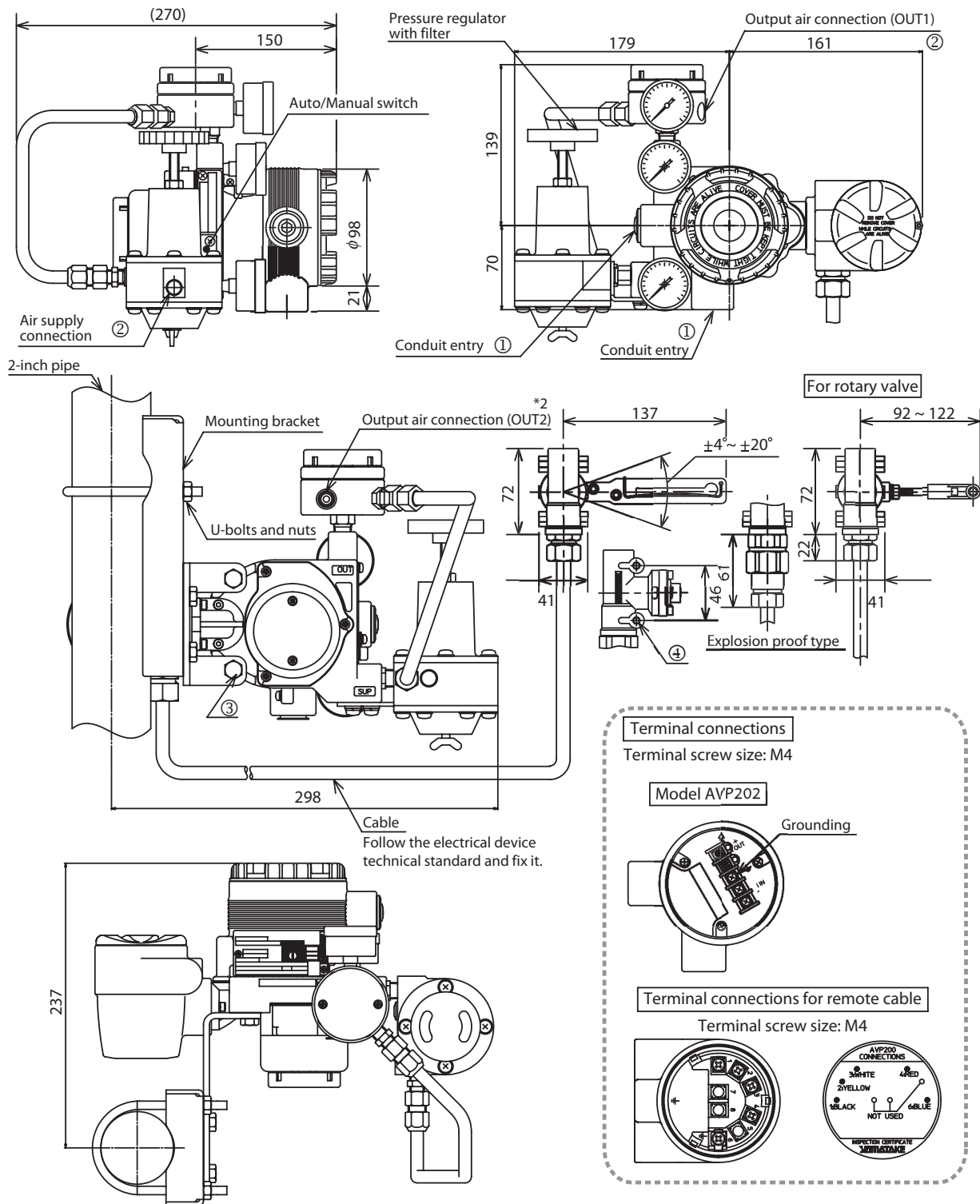

Type	Electrical connection	Air piping connection	Mounting thread	
			AVP body	Valve travel detector
Water-proof / TIS Flameproof	G1/2	Rc1/4	M8	M6
Water-proof	1/2NPT	1/4NPT	5/16-18UNC	1/4-20UNC
Parts on drawings	①	②	③	④

For double acting actuator with pressure regulator with filter

[Unit: mm]

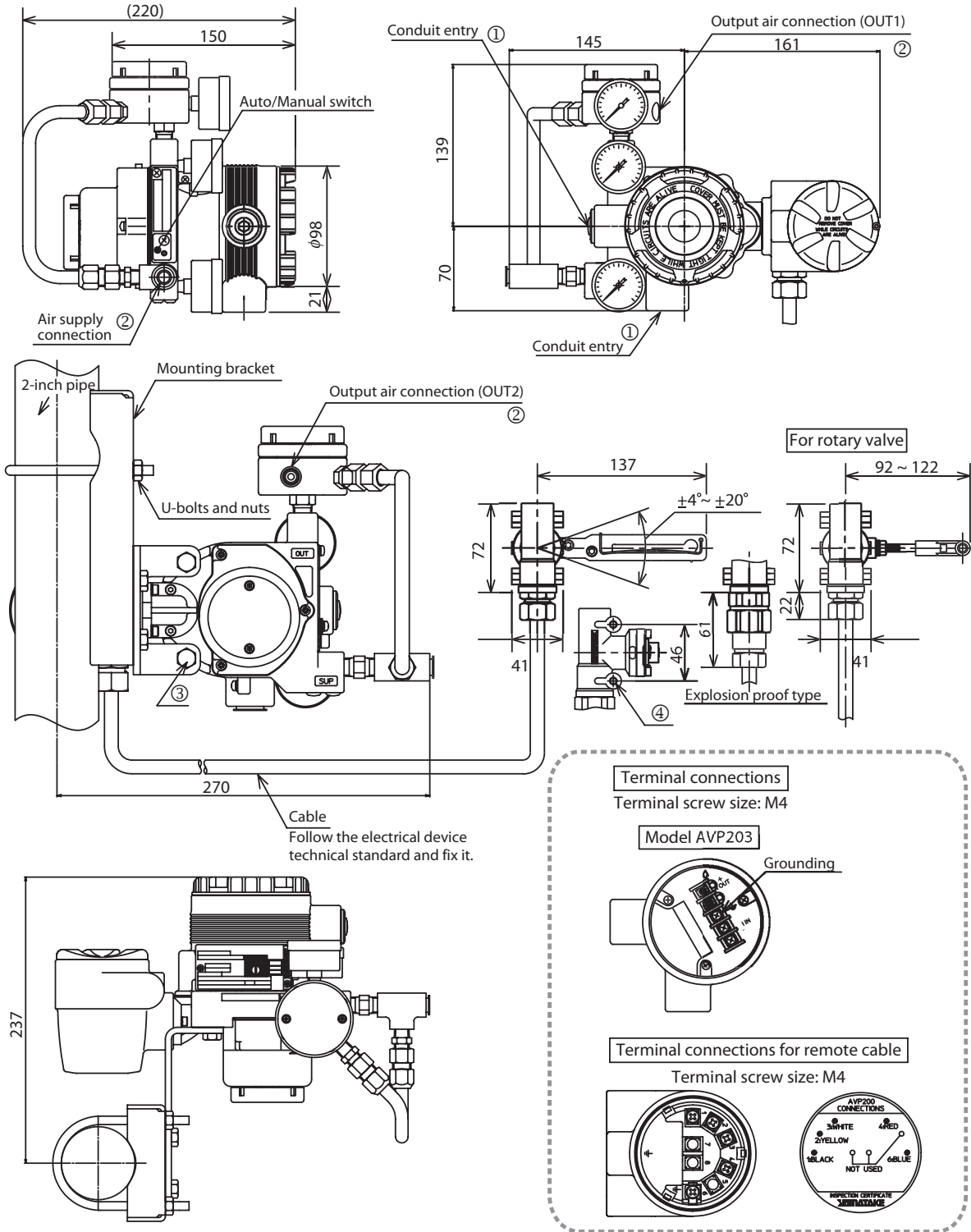

Type	Electrical connection	Air piping connection	Mounting thread	
			AVP body	Valve travel detector
Water-proof/ TIS Flameproof	G1/2	Rc1/4	M8	M6
Water-proof	1/2NPT	1/4NPT	5/16-18UNC	1/4-20UNC
Parts on drawings	①	②	③	④

For rotary valve actuator

[Unit: mm]

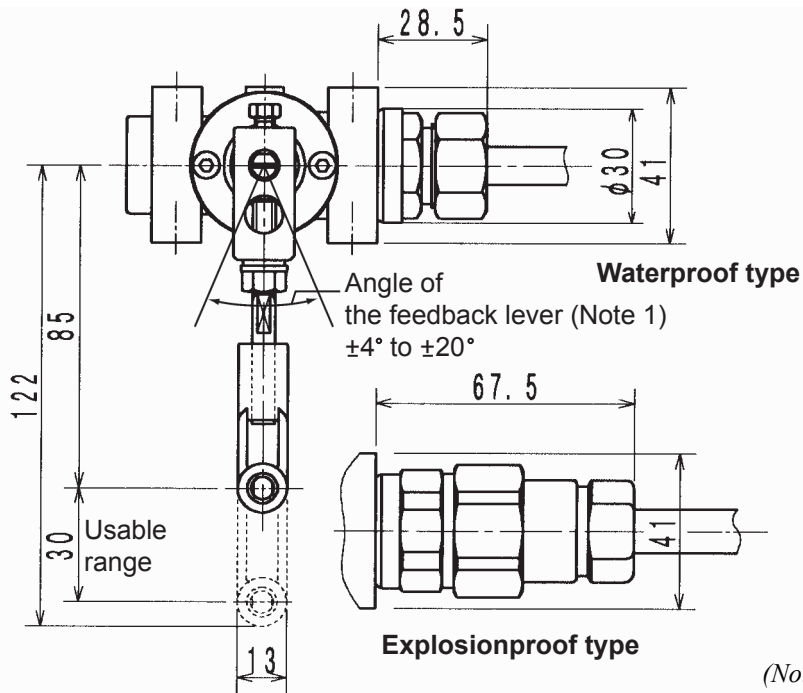

(Note 1) Rotary angle should never exceed $\pm 30^\circ$.

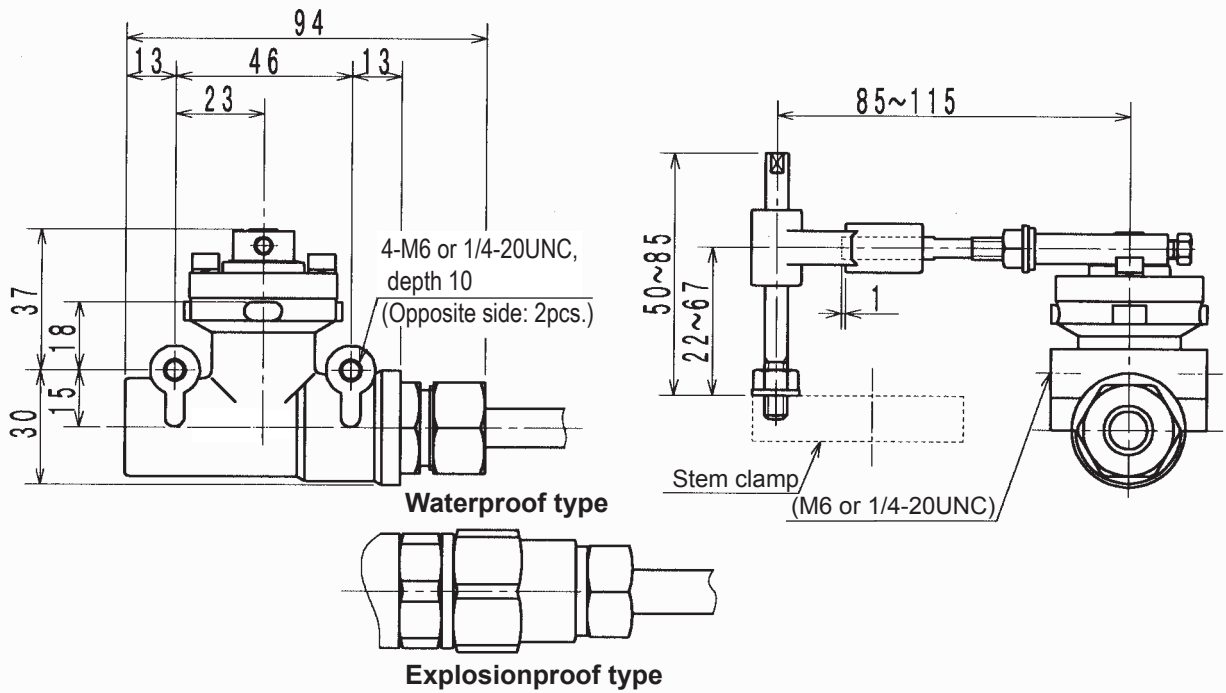

Specifications are subject to change without notice.

Yamatake Corporation
Advanced Automation Company

1-12-2 Kawana, Fujisawa-shi
Kanagawa-ken 251-8522 Japan

URL:<http://www.azbil.com>

No part of this publication may be reproduced or duplicated without the prior written permission of Yamatake Corporation.

azbil

Dec. 2000–Y/Y
Feb. 2012 (rev.10)–Y/Y