

SVP3000 Alphaplus

Smart Valve Positioner

Model AVP100/102

OVERVIEW

SVP3000 Alphaplus series Smart Valve Positioners are microprocessor based current-to-pneumatic valve positioners. The SVP3000 Alphaplus receives a DC current signal from control devices and controls the openings of valves. In addition to this basic function, SVP3000 Alphaplus has communication capabilities, automatic configuration program, and self-diagnostics functions that increase productivity and efficiency of plant operation.

FEATURES

Easy to use, easy to maintain

- **Auto setup**

Its auto-setup software is a fully- automatic configuration program.

Unlike other brands of smart positioner, the SVP3000 Alphaplus has no external device requirements. No handhelds or Pc are required for basic configuration and the program can be run off a switch.

- **Smart field communication**

Smart communication is possible for calibration and configuration of SVP using Yamatake's Smart Field Communicator (SFC) that is compatible for use with all Yamatake smart field instruments.

HART communicator model 275 can be used for calibration, configuration and self-diagnostics.

Valve diagnostic

(for model AVP102, software version 4.9 or newer)

Following parameters can be monitored by HART communicator or Control Valve Maintenance Support System "Valstaff".

- | | |
|--------------------|----------------------|
| • Stick Slip | • Cycle Count |
| • Total Stroke | • Shut-Off Count |
| • Travel Histogram | • Max. Travel Speed. |

Optimum settings for various application

- **Positive seating setting**

When the process needs tight shut-off of valves, this setting assures valve's original shut-off performance continuously by cutting off unnecessary supply pressure to actuator at a specified signal point.

- **Flow characteristic customization**

Valve's overall characteristics can be modified to suit the installed process by setting customized In/Out characteristic of positioner.



- **Precise split-range setting**

SVP can be installed for split range applications with no extra instrumentation. Because signal range can be configured easily using the Smart Field Communicator, you can optimize positioner's signal range to the process character.

Effective and reasonable maintenance

- **Reduce spare-parts inventory**

Because every specification can be changed through software configuration, lower spare parts inventory is possible.

- **Self-diagnostics**

Self-diagnostics program of SVP assures quick and correct action for failure of control valves.

For both of single acting actuator and double acting actuator

With reversing-relay, SVP can be mounted on double acting actuator.

For both of linear motion actuator and rotary motion actuator

With mounting bracket for rotary motion actuator, SVP can be mounted on rotary motion actuator easily.

FUNCTIONAL SPECIFICATIONS**Applicable actuator**

- Single and double acting actuator
- Linear and rotary motion actuator

Approvals**NEPSI Intrinsically safe approval for model AVP100**

Ex ia IIC T4-T6 T4 at -20°C to +60°C
 T5 at -20°C to +60°C
 T6 at -20°C to +40°C

Certificate No. GYJ01292

Maximum Electrical Parameters

$V_i=30V$, $I_i=95mA$, $P_i=0.66W$, $C_i=0$, $L_i=0.2mH$

Maximum Allowed Cable Capacitance 0.06 μF

Maximum Allowed Cable Inductance 1 mH

It should be used as intrinsic safety system together with NEPSI certified Zener Barrier(s), MTL728, Z728, LB928, KN9710, LB787S, MTL787S, Z787 or LB901.

NEPSI Intrinsically safe approval for model AVP102

Ex ia IIC T4-T6 T4 at -40°C to +60°C
 T5 at -40°C to +60°C
 T6 at -40°C to +40°C

Certificate No. GYJ04236

The barriers should be NEPSI certified types and comply with the following condition as follows.

$U_i=30V$, $I_i=100mA$, $P_i=1.0W$, $C_i=15nF$, $L_i=0.2mH$

The circuit shall be considered to be connected to ground from a safety point of view.

Control signal input

4-20 mA DC (Split Range Configurable-4mA span Min.)

Input resistance

Model AVP100: 300 Ω max./ 20 mA DC

Model AVP102: 600 Ω max./ 20 mA DC

Output characteristics

- Linear, Equal percentage, Quick opening
- Custom user characteristics (16 points)

Stem travel range

Feedback lever Angle $\pm 4^\circ$ to $\pm 20^\circ$

Valve stem rotation 90° max. (rotary motion actuator)

Bypass operation

Auto / Manual switch (For single acting actuator only)

Air supply pressure

140 to 700 kPa (1.4 to 7.0 kgf/cm²)

Air consumption

4 $\ell(N)$ /minutes maximum at 140 kPa (1.4 kgf/cm²)

5 $\ell(N)$ /minutes maximum at 280 kPa (2.8 kgf/cm²)

6 $\ell(N)$ /minutes maximum at 500 kPa (5.0 kgf/cm²)

10 $\ell(N)$ /minutes maximum at 400 kPa (4.0 kgf/cm²) for double acting actuator

Maximum air deliver flowrate

110L(N)/minutes at 140 kPa (1.4 kgf/cm²)

250L(N)/minutes at 400 kPa (4.0 kgf/cm²) for double acting actuator

Output balanced pressure

55+5% for double acting actuator only

Lightning protection

Peak value of voltage surge: 12 kV

Peak value of current surge: 1000A

Vibration tolerance

2G (5 to 400 Hz) with standard mounting kit on Yamatake

HA actuator

Ambient temperature limits

-40°C to 80°C for general model

NEPSI Intrinsically safe: -20°C to 60°C

Ambient humidity limits

10% to 90% RH

Configuration tools

Model SFC160 or SFC260 (SFC Smart Field

Communicator, Software version 7.8 or newer)

HART communicator model 275 (for model AVP102)

(According to need, please update a software and device description files.)

PERFORMANCE SPECIFICATIONS**Accuracy**

For 8 mA \leq input signal span \leq 16 mA

$\pm 1\%$ F.S. ($\pm 2.5\%$ with custom output characteristics)

For 4 mA \leq input signal span $<$ 8 mA, $\pm 1.5\%$ F.S.

PHYSICAL SPECIFICATIONS**Enclosure classification**

IEC529 IP66, NEMA Type 4X equivalent

Finish

Baked acrylic

Color

Dark blue

Material

Body: Aluminum casting

Pilot relay cover: PBT

Weight

Positioner: 1.7 kg

Options

Reversing relay: 0.3 kg

INSTALLATION**Air connections**

1/4NPT internal thread

Electrical connections

1/2NPT internal thread

Conditions of supply air**Particles**

Maximum diameter 3 μm

Oil mist

None acceptable

Dew point

10°C below ambient temperature

TYPICAL INSTALLATION

Figure 1 shows wiring for model AVP100/102 (Smart positioner). In this case, you can communicate with SVP at its terminal.

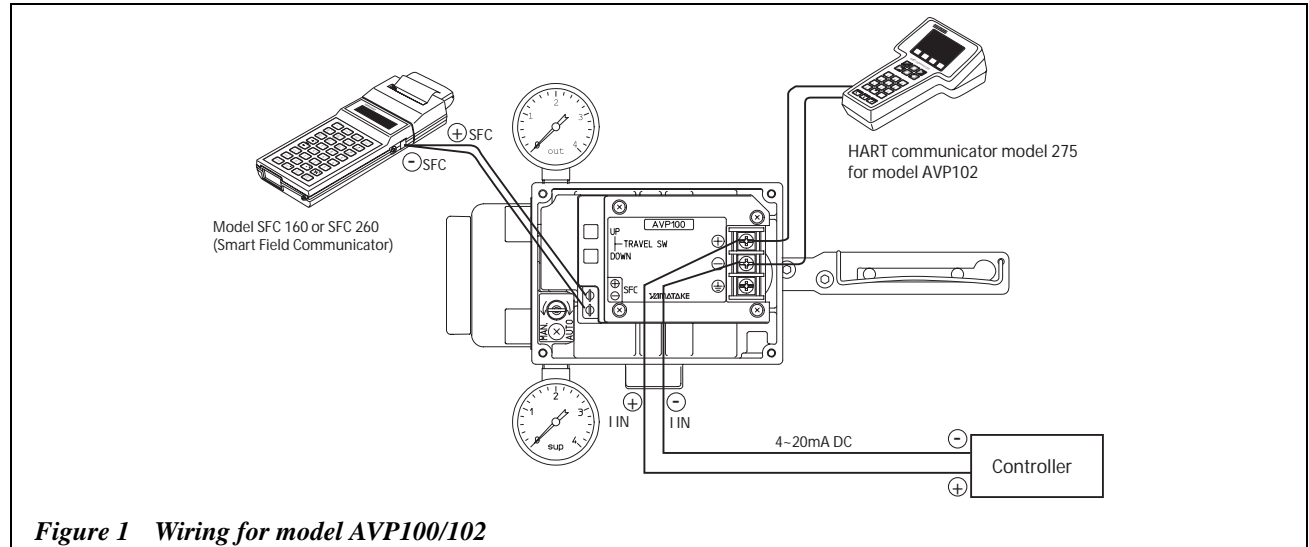

Figure 1 Wiring for model AVP100/102

MODEL SELECTION

Model AVP100 - Selections (1) Options (2) (3) (4)

Analog signal (4 to 20 mA DC)

Model AVP102 - Selections (1) Options (2) (3) (4)

Analog signal (4 to 20 mA DC) with HART communication protocol

Selections

| | | | | | Code |
|---------------|--------------------------|-----------------------|-----------------------|-----------------|------|
| (1) Structure | Connection | Air piping connection | Electrical connection | Mounting thread | |
| | Water-proof | 1/4 NPT internal | 1/2NPT internal | M8 | P |
| | NEPSI Intrinsically safe | 1/4NPT internal | 1/2NPT internal | M8 | H |

Options

| (2) Feedback lever set | (3) T joint for gauge | (4) Pressure gauge | Code | | |
|------------------------|---|--|------|-----|-----|
| | | | (2) | (3) | (4) |
| ○ | × | × | L | X | X |
| ○ | ○ T joint for gauge (2 pcs.) | ○ 400 kPa gauge (130 kPa ≤ Supply air pressure < 300 kPa) | L | S | F |
| ○ | ○ T joint for gauge (2 pcs.) | ○ 1000 kPa gauge (300 kPa ≤ Supply air pressure ≤ 700 kPa) | L | S | T |
| ○ | ○ T joint for gauge (1 pc.) and for reversing relay (1 pc.) | ○ 1000 kPa gauge (300 kPa ≤ Supply air pressure ≤ 700 kPa) | L | W | T |

Reversing relay for double acting actuator

Reversing relay for double acting actuator (Springless actuator)

Configuration Following shows default and optional settings of each configurable parameter of SVP

Unless otherwise specified, the Smart Valve Positioner will be shipped with the following configuration

- | | | |
|--------------------------|--------------------------|--|
| 1. Input control signal | 4 to 20 mA | The minimal span for custom range = 4 mA |
| 2. Output characteristic | Linear | EQ or QO can be ordered or set by user. |
| 3. Valve action | Direct (Plug above seat) | Reverse (Plug below seat) can be ordered or set by user. |
| 4. Positioner action | Direct | Reverse can be ordered. |

DIMENSIONS

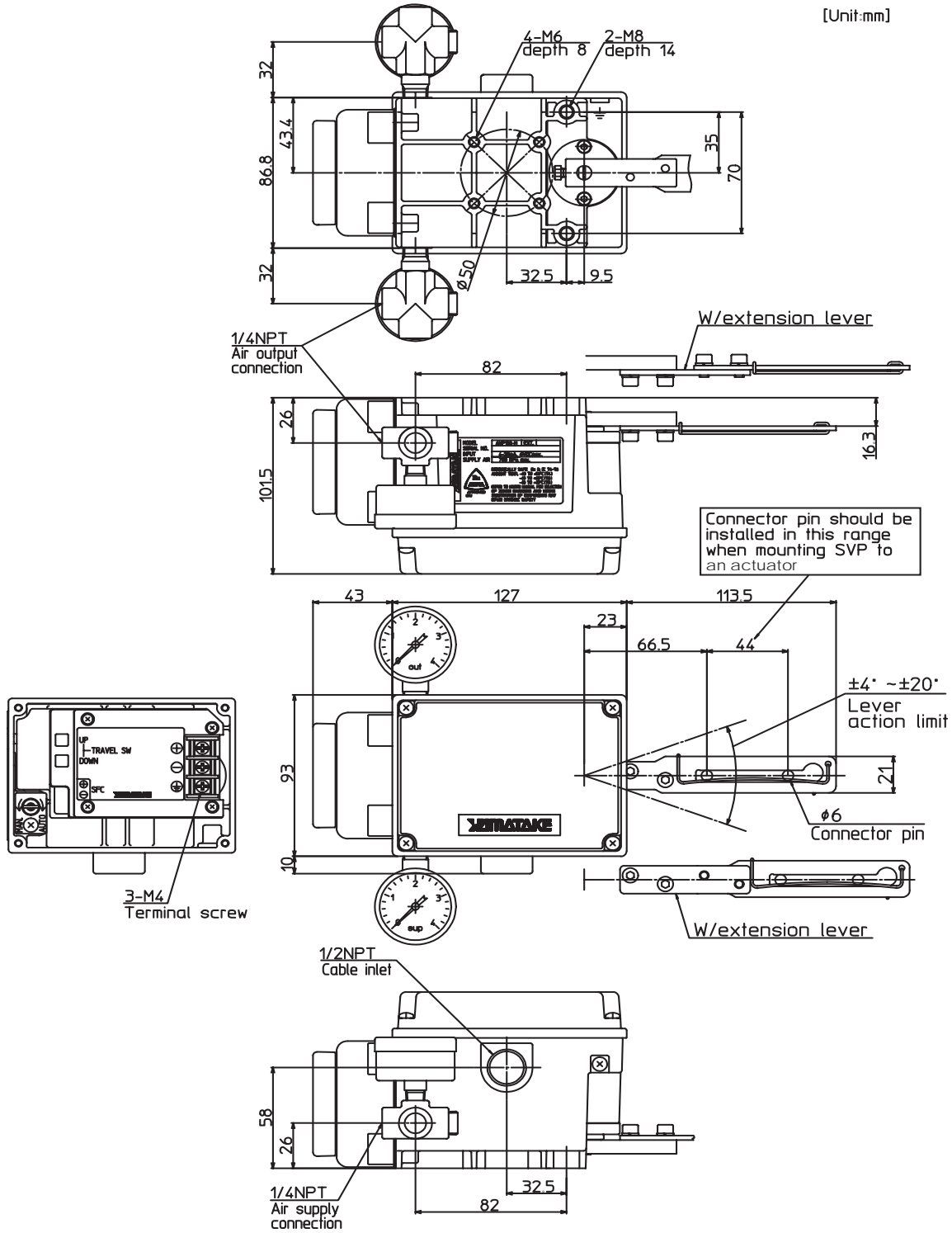

* HART is registered trademark of the HART Communication Foundation.

Yamatake Corporation

Totate international Building
2-12-19 Shibuya
Shibuya-ku, Tokyo 150-8316
Japan
Tel : 81-3-3486-2310
Fax : 81-3-3486-2593

YAMATAKE
Savemation
Saving through Automation