

Air Volume Booster

Model VF01

Introduction

The air volume booster (VF01) is essentially a large capacity pneumatic relay designed to improve pneumatic operating speed of a valve actuator, resulting in reducing time lag. The booster is recommended to use when a pneumatic signal pressure from a controller has to be transmitted over an extremely long distance or a diaphragm actuator has a large capacity (time lag is most likely caused in such cases).

The actuator responses more sensitively to pneumatic signals if aided by the booster. Application of the adjustment restriction will eliminate possible over-shootings and huntings, thus ensuring most optimum response.

Standard specifications

Model : VF01

Signal pressure : 0.2~2.8kgf/cm² {20~270kPa}

Input to output air pressure ratio : 1 : 1

Supply pressure : 1.4kgf/cm²{140kPa}(standard),
7.0kgf/cm²{690kPa}(maximum)

Air consumption : 1.5Nℓ/min.

Maximum capacity of air flow : 140Nℓ/min. (at supply air pressure 1.4kgf/cm²{140kPa})

Operating speed : The operating speed can be increased by several times when the diaphragm motor positioner is used.

Speeds obtained through Air-O-Motors :

A · O · M Model number	Stroke (mm)	Time required for full process (second)
VA1D, R	25	1.5
VA2D, R	37.5	3.0
VA3D, R	50	6.0

Material :

Body; Anti-corrosive alloy and brass

Pilot part; SUS304

Diaphragm; Chloroprene rubber with fabric reinforced

Connection :

Signal, supply and output; Rc $\frac{1}{4}$ or $\frac{1}{4}$ NPT internal thread

Ambient temperature : -30 to +80°C

Dimensions : Refer to Figure 3, Page 2.

Weight : 1.4kg



VF01

Dimensions

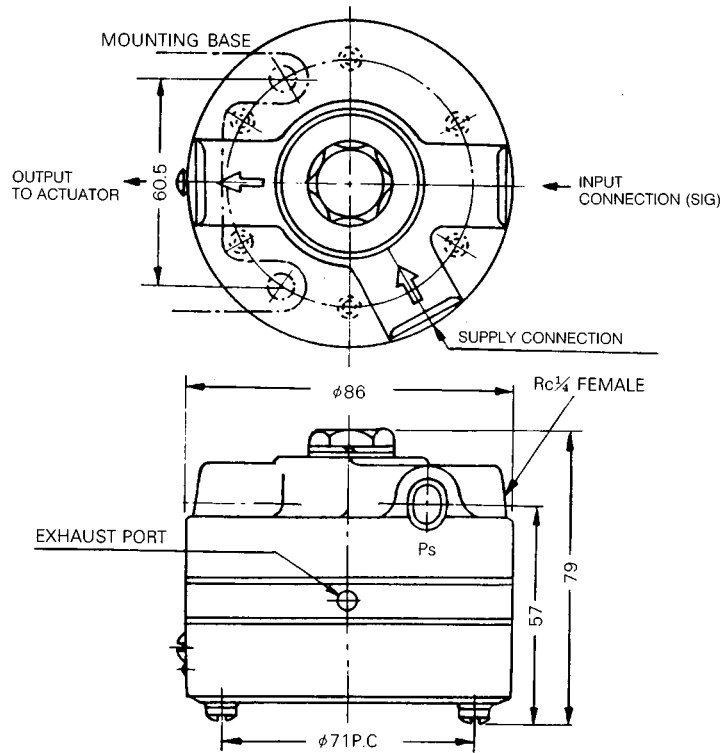

YAMATAKE
Savemation
Saving through Automation

Yamatake Corporation

Totate International Building
 2-12-19 Shibuya
 Shibuya-ku, Tokyo 150-8316
 Japan
 Tel : 81-3-3486-2310
 Fax : 81-3-3486-2593



Certificate No. Q17862

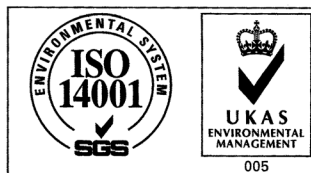

Certificate No. E8318
 For Shonan Factory