

**CV3000 Series
Electro-Pneumatic
Valve Positioners
Model : HEP 15/16/17
(Single Acting Type)
User's Manual**



Yamatake Corporation

Copyright, Notices and Trademarks

Printed in Japan - © Copyright 1998 by Yamatake Corporation

While this information is presented in good faith and believed to be accurate, Yamatake Corporation disclaims the implied warranties of merchantability and fitness for a particular purpose and makes no express warranties except as may be stated in its written agreement with and for its customer.

In no event is Yamatake Corporation liable to anyone for any indirect, special or consequential damages. The information and specifications in this document are subject to change without notice.

TABLE OF CONTENTS

	<u>PAGE</u>
1. GENERAL	1
1.1 GENERAL DESCRIPTION	1
1.2 COMPOSITION	1
1.3 SPECIFICATIONS	2
2. OPERATING PRINCIPLES	4
3. INSTALLATION	6
3.1 MOUNTING OF CONNECTOR PIN ASSEMBLY	6
3.2 MOUNTING THE POSITIONER	6
3.3 POSITION ADJUSTMENT	7
3.4 COUPLED DIMENSIONS	8
4. EXTERNAL CONNECTIONS	9
4.1 AIR PIPING CONNECTIONS	9
4.2 ELECTRICAL CONNECTIONS	9
5. ADJUSTMENT	10
5.1 ADJUSTMENT	10
5.2 MODIFICATION FOR DIRECT/REVERSE ACTION CHANGE	11
6. TO MATCH COPE INPUT SIGNAL	12
7. TO COPE WITH ACTUATOR	13
7.1 TO COPE WITH AIR SUPPLY PRESS	13
7.2 TO COPE WITH ACTUATOR SIZE	13
7.3 TO COPE WITH ACTUATOR CAPACITY	13
7.4 MODIFICATIONS OF POSITIONER CHARACTERISTICS	14
8. MAINTENANCE AND TROUBLESHOOTING	19
8.1 GENERAL PRECAUTIONS	19
8.2 TROUBLESHOOTING	20
SUPPLEMENT (BYPASS MANIFOLD)	22

1. GENERAL

1.1 GENERAL DESCRIPTION

Model HEP I/P Valve Positioner is used to drive a control valve more rapidly and accurately. The positioner, being coupled to an actuator, is installed on a control valve and converts the electrical current signal received from the controller into a pneumatic signal which is fed to the actuator. The positioner is available for explosionproof construction as shown in the below table. The housing of positioner is splashproof (complies with JIS F 8001 Class 3 Splashproof Construction).

Explosionproof construction	Applicable areas
"Pressure-tight Explosionproof Construction" JIS C 0903, d2G4	Hazardous areas of Classes 1 and 2 of JIS, and areas indicated by the recommendations mentioned in the left column. Non-hazardous areas.

1.2 COMPOSITION

Model HEP I/P Valve Positioner is comprised of a magnet unit which converts the electrical current input signal into a mechanical displacement force signal, a nozzle-flapper mechanism which converts the displacement force signal into a nozzle back-pressure signal, a pilot relay which boosts the nozzle back-pressure signal, a feedback lever mechanism which feeds back the valve stem position signal, a span adjustment mechanism, etc. The housing is made of an aluminium alloy in a splashproof structure and its inside is constantly purged by the vent air of the nozzle.

The pressure-tight explosionproof feature is attained by the terminal block and magnet unit which are structured to the tight against pressures caused by explosions. This allows you to remove the housing cover to inspect the instrument even in a hazardous area. The intrinsically safe explosionproof feature is attained by connecting two spark killer diodes connected in parallel to the magnet coil and employing a barrier (receiver).

1.3 SPECIFICATIONS

Material of Housing: Aluminium alloy

Finish color

Housing: Dark beige (Munsell 10YR4.7/0.5)

Housing Cover: Light beige (Munsell 4Y7.2/1.3)

Input Signal: 4 - 20 mADC
10 - 50 mADC (Model HEP15 only)

Electrical Conduit Connections: G1/2 internal thread

Input Resistance: 250 ± 10 Ω (for 4 - 20 mADC input)
100 Ω (for 10 - 50 mADC input)

Air Supply: 140 - 350 kPa { 1.4 - 3.5 kgf/cm² },
360 - 490 kPa { 3.6 - 5.0 kgf/cm² }

Air Consumption: 4 Nℓ/minute (when in steady state with air supply 140 kPa { 1.4 kgf/cm² })

Maximum Air Passage Rate: 140 Nℓ/minute (when in steady state with air supply 140 kPa { 1.4 kgf/cm² })

Air Piping Connections: Rc1/4 (standard), 1/4 NPT internal thread

Ambient Temperature: -30 to +80°C

Ambient Humidity: 10 - 90% RH

Explosion-proof structure: Explosion-proof structure:

Explosion-proof type (HEP 15)

- o With explosion-proof terminal box or one with pressure tight packing type cable adaptor.

Complies with JIS C 0903 Explosion-proof Class d2G4 (and JIS F 8001 Class 3 Splash-proof; within ambient temperature -10 to +70°C)

- o NEC Class 1, Group C. D, Division 1 equivalent

Intrinsic safety type (HEP 16)

Complies with JIS C 0903, Class i3aG5 (with signal line supply voltage: 23 to 27.5 V DC, ambient temperature: -10 to +60°C)

Weatherproof type (HEP 17)

Equivalent to JIS F 8001 class 3 splash-proof construction

Output Characteristics: Linear

Accuracy: ± 1% FS

Dead Zone: 0.1% or less

Travel Adjustment Range: 10 - 100 mm

Maximum Travel Speed: 4 mm/s (with HA2D or HA2R actuator)

Weight: 3.5 kg (4.2 kg if regulator valve is provided)

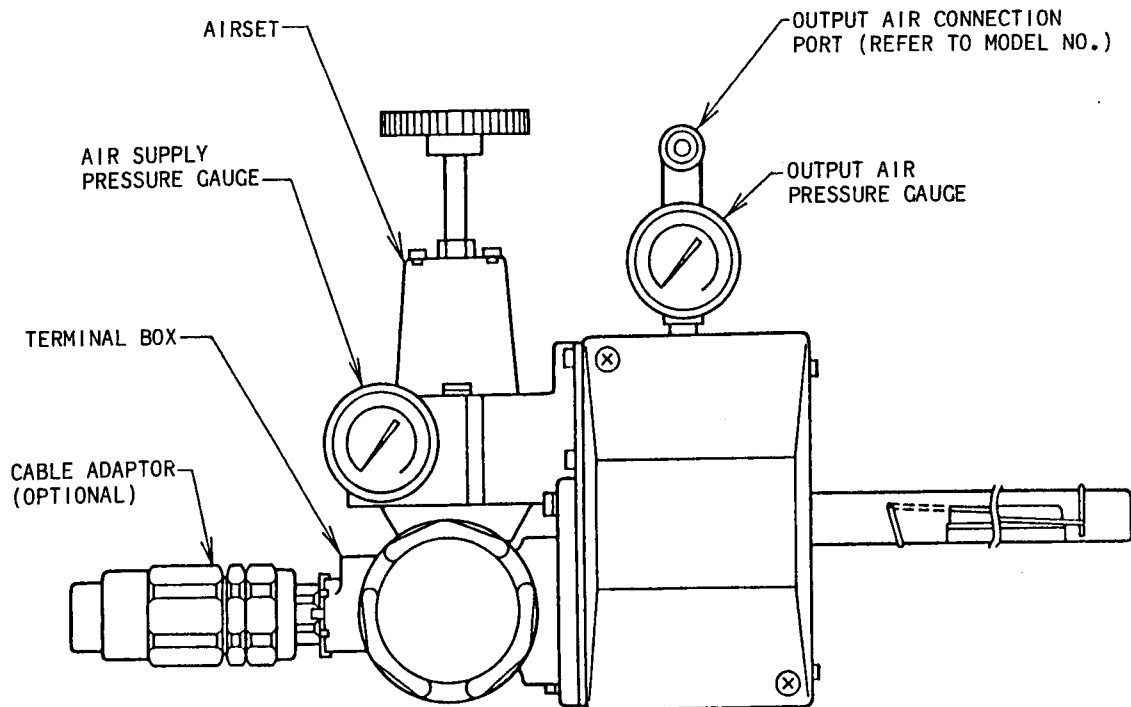

Fig. 1. Front View of HEP Positioner (with Airset, Cable Adaptor, and Air Supply and Output Pressure Gauges)

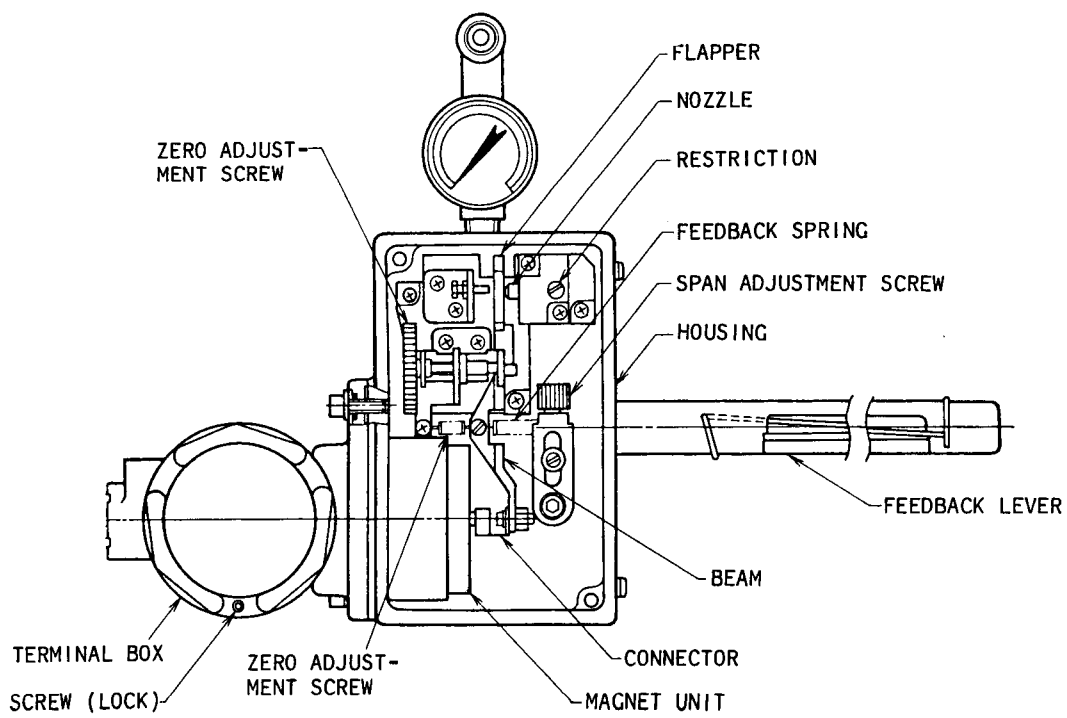

Fig. 2. HEP Positioner (with Cover Removed)

2. OPERATING PRINCIPLES

The HEP positioner operates on a force balance system as shown in Fig. 3. When in the steady state, the system is balanced by means of the feedback loop. When the torque of the magnet unit is changed due to input signal change, friction, or reaction from the process flow and consequently the force is unbalanced from that exercised by the feedback spring in response to displacement of the actuator stem, the positioner controls its output pressure fed to the actuator so that the loop is balanced and the valve stem is maintained at a position corresponding to the input signal of the positioner.

Taking for the example the reverse action type of actuator (the actuator stem rises as the air pressure fed to the actuator increases), a brief description of the positioner operation follows: Assume that the input signal of the positioner which has been in the balanced state has increased. The signal increase drives the nozzle flapper in the closing direction and consequently the back pressure of the nozzle increases. The back pressure increase is boosted by the pilot relay and fed to the actuator. The actuator stem moves in response, thereby controlling the valve position. The valve position change is fed through the feedback lever and span adjustment mechanism to the feedback spring, thereby making up a negative feedback loop for force change of the magnet unit. Consequently, the nozzle flapper is controlled at the position for the pressure which holds the actuator stem at the position corresponding to the input signal.

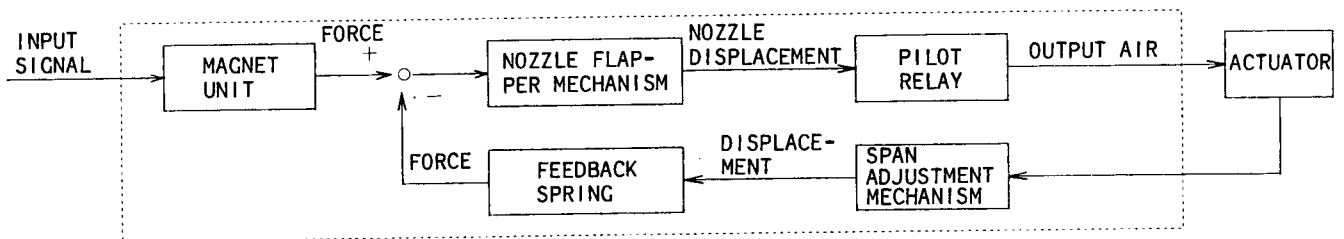

Fig. 3. Block Diagram of HEP Positioner

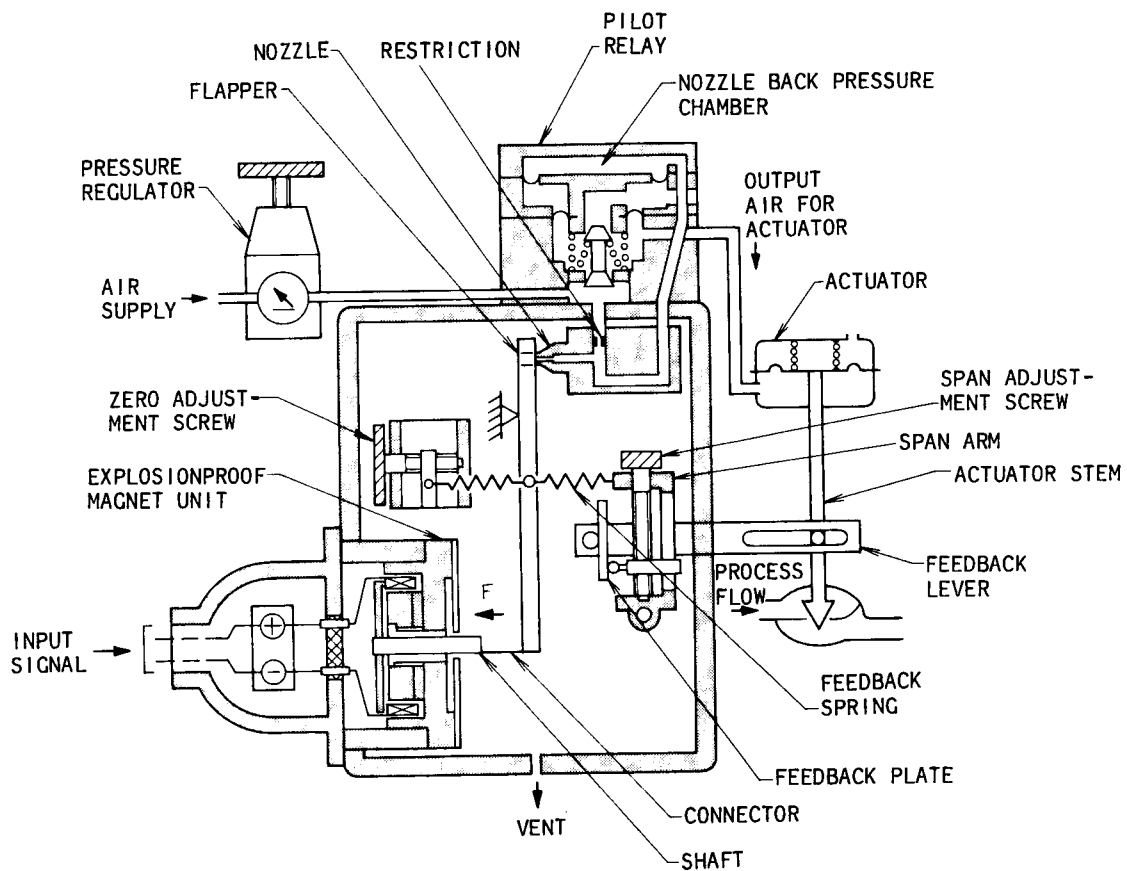

Fig. 4. Operating Principle of HEP Positioner

3. INSTALLATION

The HEP positioner ordered as an accessory of a control valve is delivered being installed on the control valve and with adjustment complete. When an HEP positioner is ordered as an independent item, install it on the control valve as described in this section. The installation work consists of three major steps, namely, mounting of the connector pin assembly, mounting of the positioner housing, and position adjustment.

3.1 MOUNTING OF CONNECTOR PIN ASSEMBLY

Fix tentatively the connector pin assembly to the pointer with the flanged setscrews. (See Fig. 5.)

3.2 MOUNTING THE POSITIONER

- (1) Fix the mounting bracket to the positioner with the hex bolts (M8x20) as shown in Fig. 5.
- (2) Pass the connector pin through the oblong hole of the feedback lever and fix the positioner to the actuator with the hex bolts (M8x20) and spring washers. Set the nylon nut on the threaded section of the connector pin.

Parts	Q'ty	Parts No.
Mounting bracket	1	80357155-001
Hex bolts	4	82592042-002
Spring washers	4	82254579-005
Connector pin ass'y	1	80357142-001
Flanged setscrew	1	82592402-101
Nylon nut	1	82510399-001
Studs (for HA2 only*)	2	80357150-001

*: To install the positioner on Model HA2 Actuator, studs are needed for high alignment. Fix at first the studs to the yoke and then install the positioner.

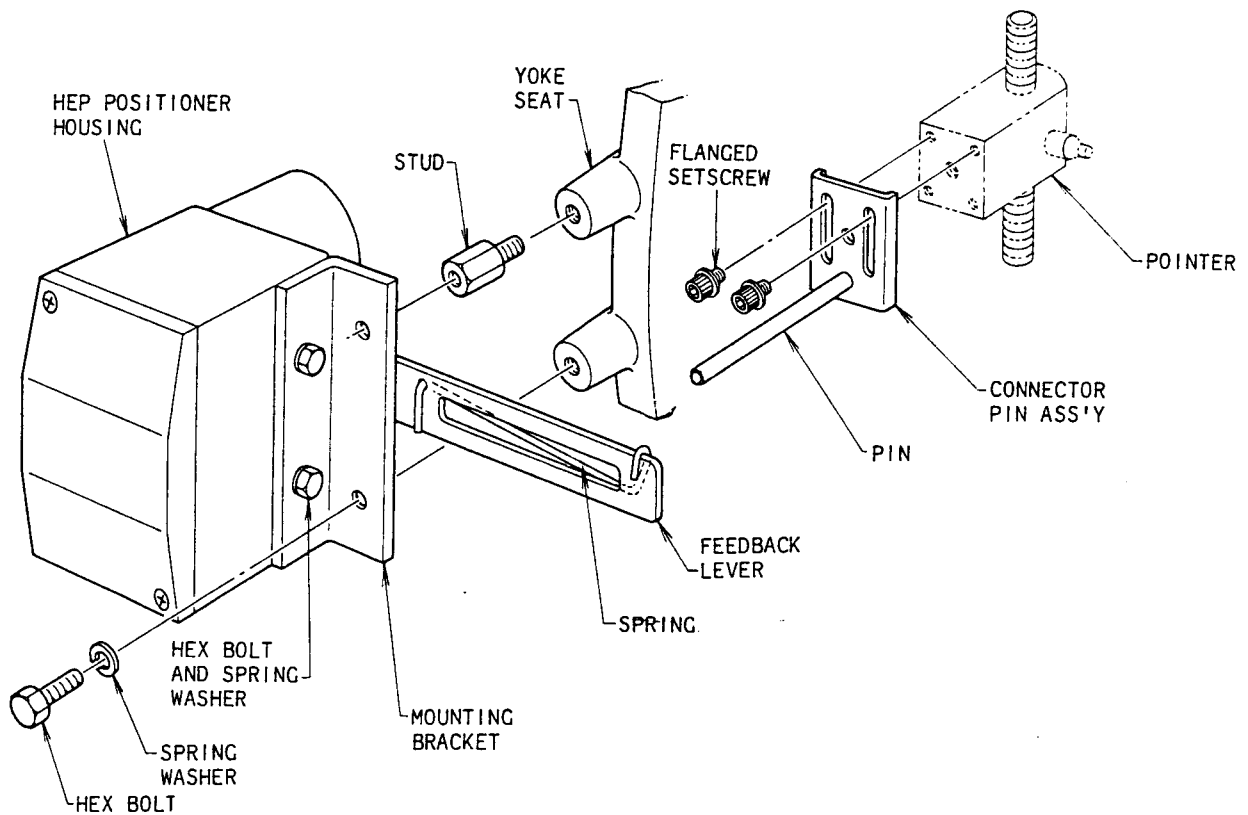

Fig. 5. Drawing for Installing the Positioner

3.3 POSITION ADJUSTMENT

After installation of the connector pin assembly and positioner is over, adjust the feedback lever position as follows, referring to Fig. 6.

- (1) Apply to the actuator through a regulator an air pressure of a value that the actuator stem is positioned at the center of its travel, by using a pressure regulator.
- (2) With the actuator stem in the above position, adjust the feedback lever angle with respect to the positioner to the right angle (90 degrees of angle) and then securely tighten the setscrews.

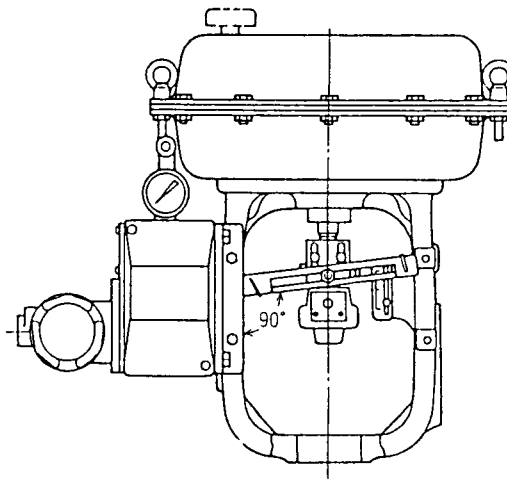

Fig. 6. Position Adjustment

3.4 COUPLED DIMENSIONS

Overall dimensions of the HEP positioner and an actuator of Yamatake Corporation coupled together are as shown in Fig. 7.

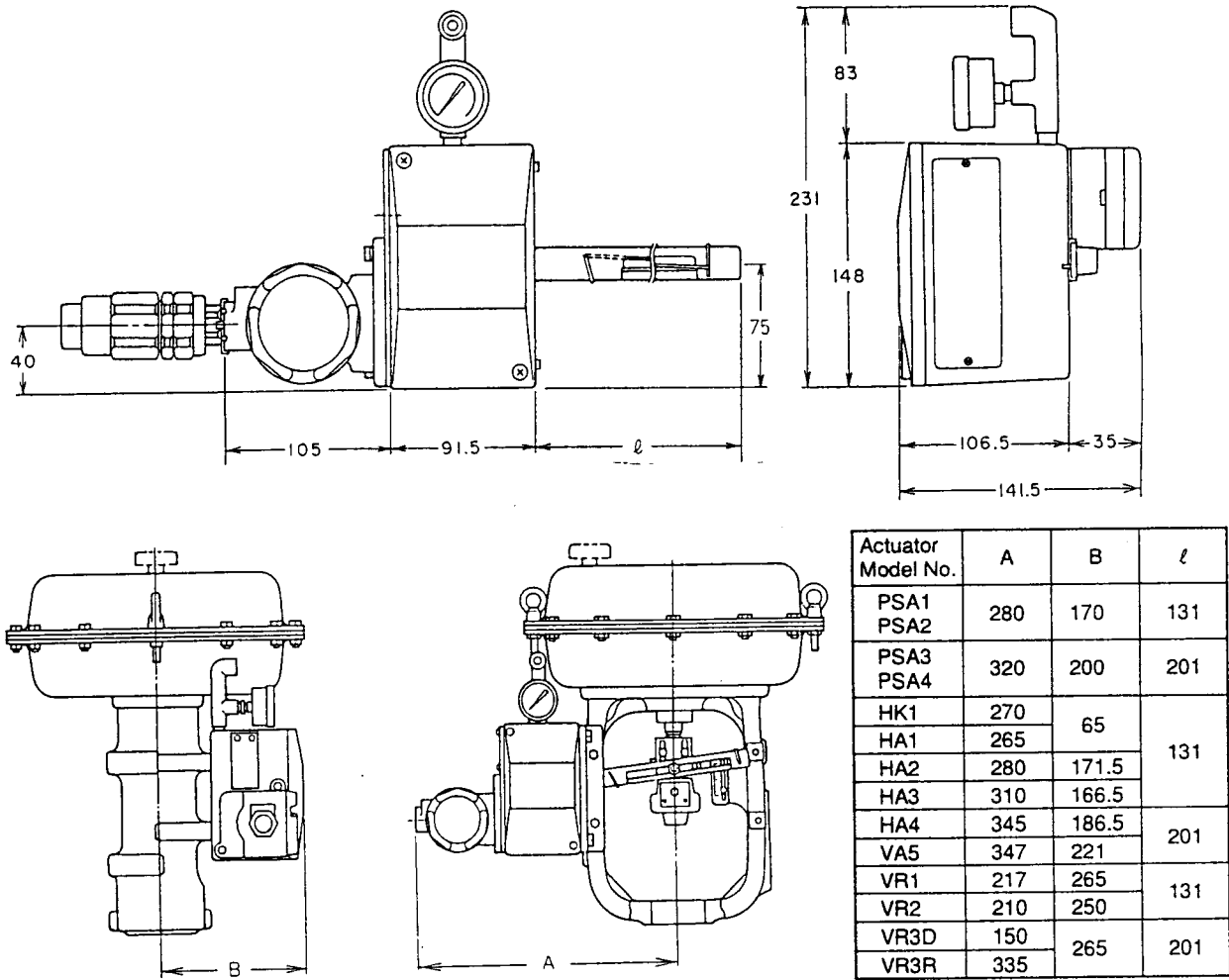

Fig. 7. Coupled Dimensions

4. EXTERNAL CONNECTIONS

4.1 AIR PIPING CONNECTIONS

The air piping connections are two: one for the air supply (marked "SUPPLY") and the other for the positioner output (marked "OUT"). When making connections, pay attention so that no seal tape or copper clips fall into and entrapped in the pipes. For air piping, use copper pipes of 8 mm dia. x 6 mm dia.

4.2 ELECTRICAL CONNECTIONS

Remove the terminal cover and connect the signal wires to the terminals — the "+" wire to the "+" terminal and the "-" wire to the "-" terminal.

For an explosionproof model, lock the cover with the screw for locking. Observe also other instructions for procedures to comply with applicable explosionproof standard.

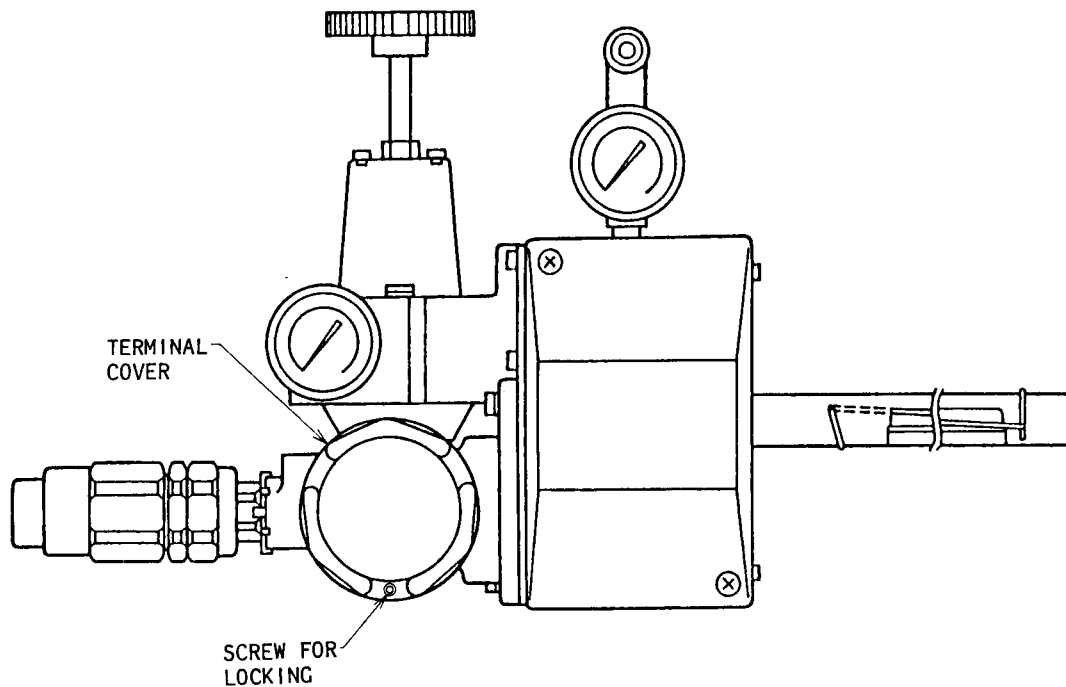

Fig. 8. Terminal Block Ass'y

5. ADJUSTMENT

In the case the positioner has been ordered to be together with the actuator, the positioner is delivered being installed on the actuator and with adjustment complete. In the case the actuator is to be installed in the field or in the case that the actuator is to be installed at an angle largely deviating from the vertical attitude, adjust the positioner as follows:

5.1 ADJUSTMENT

- (1) Apply to the actuator an air pressure at a value that the actuator stem is positioned at the center of its travel, employing a pressure regulator.
- (2) Check that, when the actuator stem is at the center of its travel, the feedback lever is at the right angle (90 degrees). If it is not at the right angle, correct it referring to Section 3 "INSTALLATION."
- (3) Disconnect the air supply pipe from the actuator and connect it to the "SUP" connection port of the positioner. Make air connection between the "OUT" connection port of the positioner and the air chamber of the actuator.
- (4) Adjust the starting point as follows: Apply an input signal corresponding to the starting point of the actuator. (This signal typically is 4 mA.)
- (5) Adjust the stroke span as follows: Apply an input signal corresponding to the full stroke point of the actuator (this signal typically is 20 mA) and read the stroke. If the stroke is insufficient, loosen the span adjustment lock screw, turn the span adjustment screw and move the lock screw in the arrowhead direction. After the adjustment is over, securely fix the span adjustment lock screw.
- (6) Repeat the procedures of (5) and (6) until the actuator travel becomes within the tolerance for the entire range.

5.2 MODIFICATION FOR DIRECT/REVERSE ACTION CHANGE

The procedure for changing the direct action to the reverse action or changing the reverse action to the direct action, only of positioners of linear characteristics, is described here. For that of positioners of other characteristics, see Section 7.4.

The mounting position of the span adjustment mechanism differs depending on whether the actuator is of the direct action type or the reverse action type. Fig. 9 shows the mounting position of the span adjustment mechanism of the reverse action type of actuator. For the direction action type of actuator, install the span adjustment mechanism on the direct action actuator mounting seat indicated at an upper position in Fig. 9, with the span adjustment mechanism turned-over upside down from that shown in Fig. 9. The mounting directions are indicated with arrowheads on the instrument, with the downward arrowhead for the direct action type and the upward arrowhead for the reverse action type.

To change the mounting directions of the span adjustment mechanism, proceed as follows: First, disengage the hook of the beam side of the feedback spring from the pin. This can be accomplished more easily by gripping the straight section of the spring with a longnose plier or other appropriate tool. Next, loosen the hex socket bolt and detach the span adjustment mechanism.

(To install the mechanism, follow the above procedure in the reverse order.)

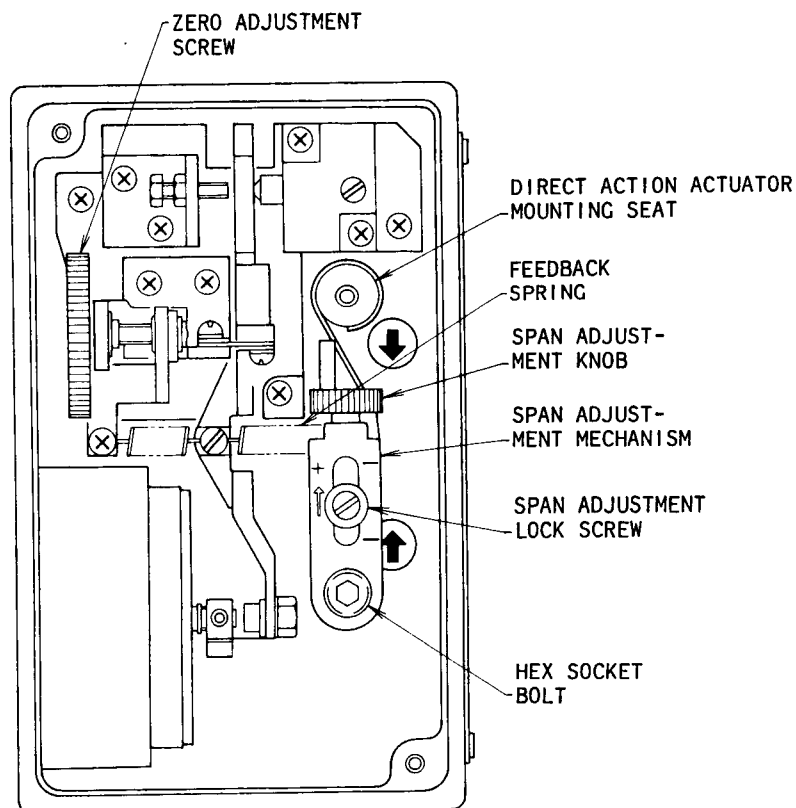

Fig. 9. Zero and Span Adjustment Mechanisms

6. TO COPE WITH INPUT SIGNAL

The standard input signal for the HEP positioner is 4 - 20 mADC. Depending on the type of the control instrument which feeds the signal to the positioner, it will have to handle other ranges than 4 - 20 mADC. When the input signal is of an over-range, a shunt resistor may be used; when the input signal is of a short-range, the feedback spring may be changed. An over-range or short-range within certain extent can be coped with simply by adjustment of the standard model of positioner without requiring any modifications.

Input signal (mADC)		Current shunt (required or not)	Input impedance (Ω)	Remarks
Span	Range (Split range)			
8	(4 - 12, 12 - 20)	No	250	Actuator travel of up to 20 mm for PSA1 or PSA2, up to 25 mm for HA2, up to 38 mm for HA3 and up to 50 mm for HA4 can be coped with by adjustment of standard model of positioner.
16	4 - 20	No	250	—
20	(10 - 30, 30 - 50)	Yes	100	In the case of split-range type, actuator travel of up to 20 mm for PSA1 or PSA2, up to 25 mm for HA2, up to 38 mm for HA3 and up to 50 mm for HA4 can be coped with by 10 - 50 mADC input type of positioner.
40	10 - 50	Yes	100	—

When the travel is 12 mm or less and down to 6 mm, an yellow color-coded feedback spring is used instead of the standard feedback spring. No other modifications are required.

When connecting the positioner to an control instrument, pay attention to impedance matching so that no voltage drop is caused to the instrument and that no large current flows in the magnet unit.

7. TO COPE WITH ACTUATOR

7.1 TO COPE WITH AIR SUPPLY PRESSURE

The HEP positioner is available either in a 140 - 350 kPa {1.4 - 3.5 kgf/cm²} type or 360 - 490 kPa {3.6 - 5 kgf/cm²} type for the air supply pressure of the pilot section. The type corresponding to the air supply pressure of the actuator should be used. So far as the actuator spring range is within the above air supply pressure range, the equipment is usable after start point adjustment and span adjustment. When the air supply pressure is changed (from 140 kPa {1.4 kgf/cm²} into 240 kPa {2.4 kgf/cm²} for example), the start point and span should be adjusted.

7.2 TO COPE WITH ACTUATOR SIZE

The HEP positioner has either a long feedback lever or a short one. A type corresponding to the actuator model number mentioned in Section 3.4 "Coupled Dimensions" should be used. The positioner with the long feedback lever can be used also for a smaller actuator. However, note that the long feedback lever may come into contact with other component.

7.3 TO COPE WITH ACTUATOR CAPACITY

The HEP positioner is incorporated with a stabilizer so that the positioner can operate in high sensitivity and reliability with the various models of actuators ranging from small ones to large ones. The stabilizer has three positions, namely A, B and C. In the order of A, B and C, the actuator speed becomes slower and hunting becomes less.

Position change can be accomplished by loosening the three clamping-screws of the pilot relay and rotating the stabilizer alone to the required position. The stabilizer of the positioner which is shipped from Yamatake Corporation after installing and adjusting it at the factory is set in the position shown in the below table.

Actuator model No.	Diaphragm chamber capacity*	Stabilizer position (Linear)	Stabilizer position (Eq%, QO)
HK1	700	D	E
HA1, PSA1	850	D	D
HA2, PSA2	1,500	A	A
PSA3	3,400	C	B
HA3	3,400	B	B
HA4, PSA4	10,000	C	C
VA5	25,300	C	C
VR1	760	D	E
VR2	2,200	B	B
VR3	5,800	C	B

* Capacity of driving section: cm³ MAX

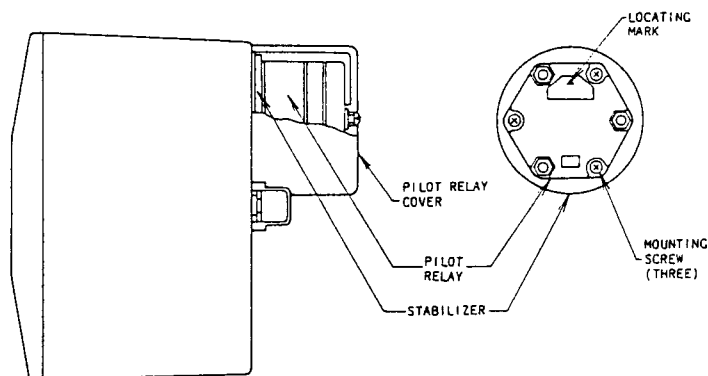

Fig. 10. Stabilizer

7.4 MODIFICATIONS OF POSITIONER CHARACTERISTICS

By changing the span adjustment mechanisms (units) of the HEP positioner, its characteristics can be changed, resulting in actuator characteristics modification and consequently in flow control characteristics modification of the control valve. The available characteristics are linear, equal percent (Eq%), and quick opening (Q/O), with direct action and reverse action for each of them.

7.4.1 Modification Procedures

- (1) To change between direct action and reverse action (except the linear positioner), change respective units (there are respective types of units).

- (2) Change between linear and Eq% or Q/O

Change the spring studs, set the spring retainer, change the units, and hook the spring(s).

- (3) Change between Eq% and Q/P

Change the units and hook the springs in the original positions.

7.4.2 Unit Replacement Procedures

The units for respective types of span adjustment characteristics are shown in Figure 11.

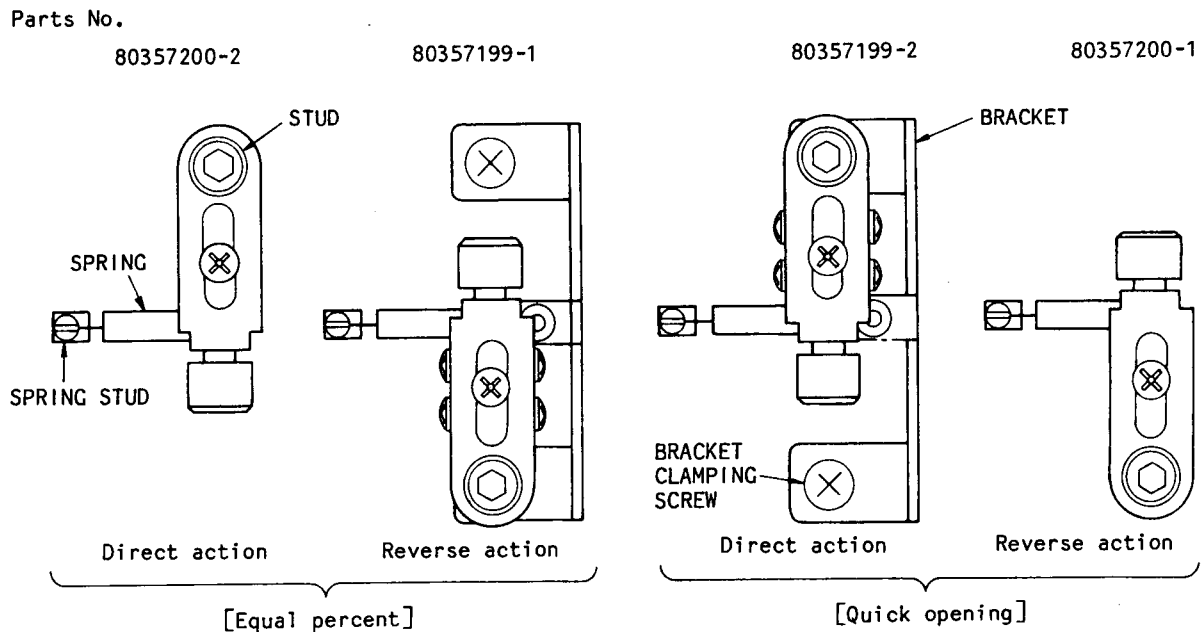

Fig. 11. Span Adjustment Mechanisms (Units)

The modification procedure is explained below taking an example from the case of converting a reverse-action linear positioner into a reverse-action equal percent positioner. Other modifications can be made in similar manners. The parts required for modifications are indicated in the following table.

Unit required	Parts required						Spring for linear unit
	Span adjustment mechanism	Bracket	Stud (long)	Retainer (long)	Stud (long)	Retainer (short)	
Quick opening (direct) Quick opening (reverse) + Linear (direct, reverse) Equal percent (direct) Equal percent (reverse)	80357080-001	x	x	x	(O)*	(O)*	80357094-001
Quick opening (direct) + { Quick opening (reverse) Equal percent (reverse) } Equal percent (direct)	80357200-001 80357200-002	x	---	---	---	---	---
Quick opening (reverse) + { Quick opening (direct) Equal percent (direct) } Equal percent (reverse)	80357199-002 80357199-001	O	---	---	---	---	---
Linear (direct, reverse) + { Quick opening (direct) Equal percent (reverse) }	80357199-002 80357199-001	O	O	O	x	x	---
Linear (direct, reverse) + { Quick opening (reverse) Equal percent (direct) }	80357200-001 80357200-002	---	O	O	x	x	---
Linear (direct) ↔ Linear (reverse)	---	---	---	---	---	---	---

* Long stud may be used instead.

O: Required

---: Not required

x: Surplus

(1) Removing the Parts

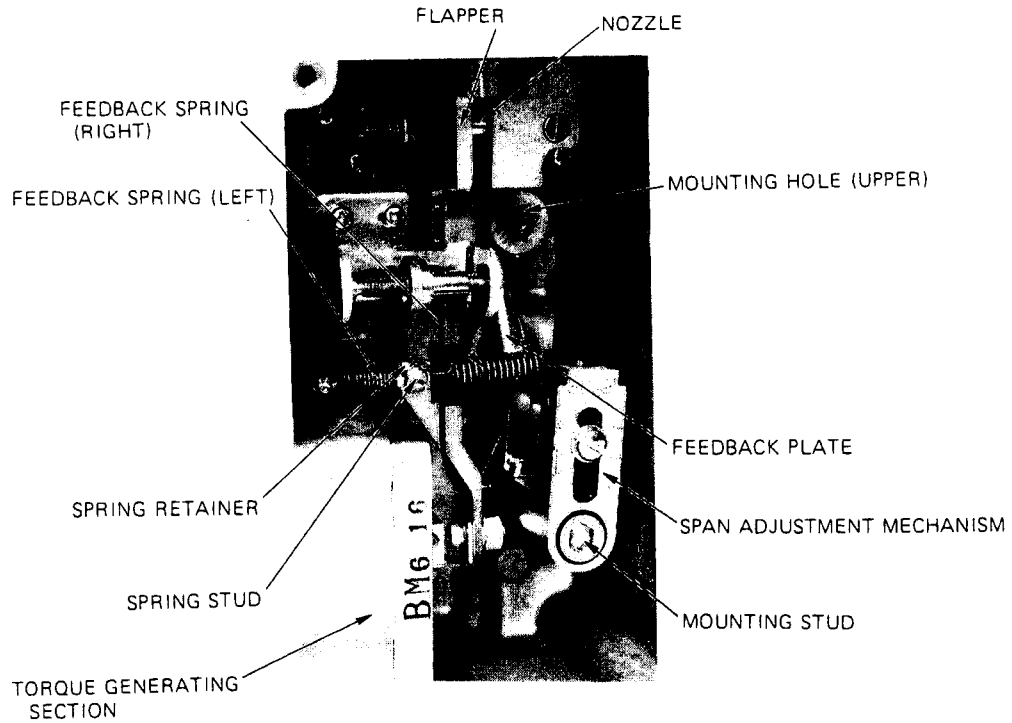

Fig. 12. Mechanism Before Modification

- ① Remove the spring stud (1) and unhook the feedback springs (right and left).
- ② Loosen the mounting stud with a hex wrench and remove the span adjustment mechanism. (The mounting stud is fixed to the mounting hole (lower).)

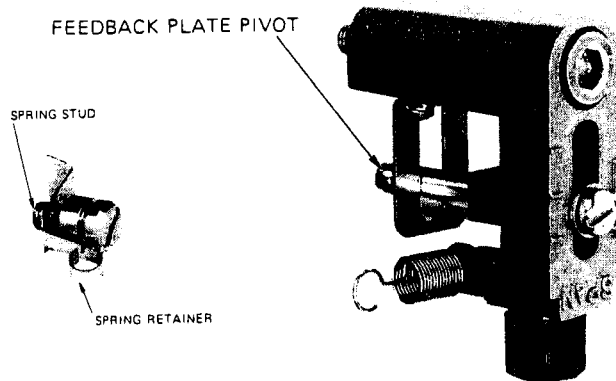

Fig. 13

(2) Installing the Parts

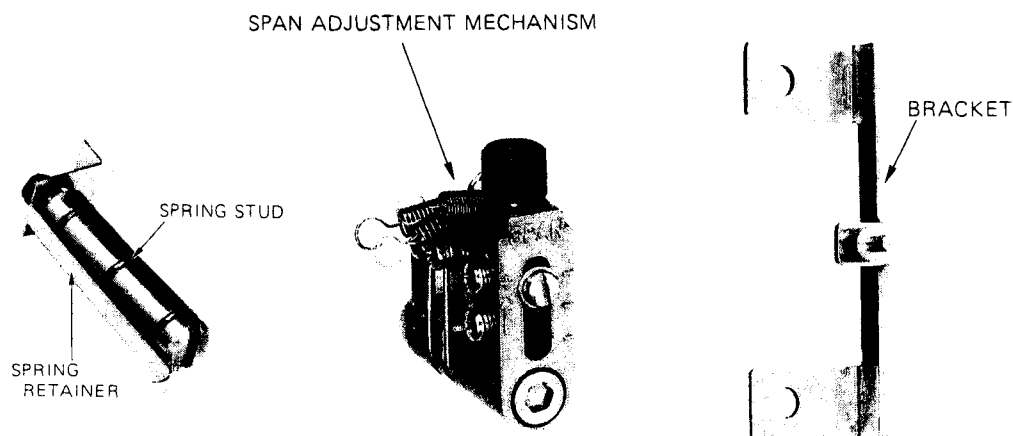

Fig. 14. Parts to be Replaced (4 Items)

- ① Pass the mounting stud of the span adjustment mechanism through the hole of the bracket and fix the stud to the mounting hole (lower) in the state as shown in Fig. 14, using a hex bar wrench.

When doing this, note that the pivot is positioned at the right hand side of the feedback plate. (See Figure 12.)

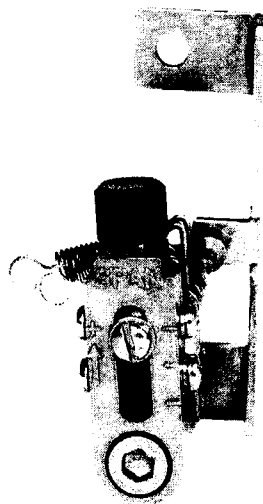

Fig. 15

- ② Pass the spring stud through the hooked sections of the three feedback springs (right) and one spring (left) and fix the spring retainer at the left hand side of the stud by means of the threaded section at the end of the stud.
- ③ Using a tweezer, settle the hooked section of the springs in the corresponding grooves of the spring stud. Settle the left spring in the groove at the base of the stud.

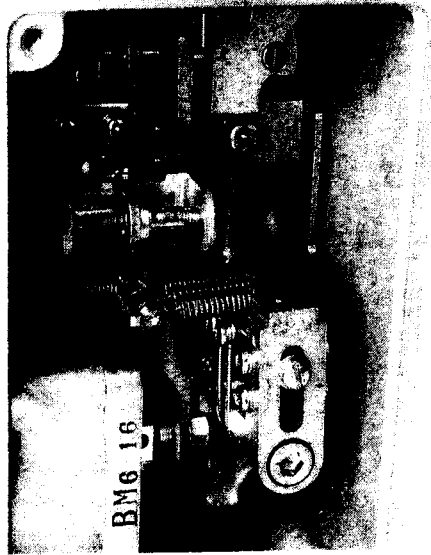

Fig. 16

8. MAINTENANCE AND TROUBLESHOOTING

8.1 GENERAL PRECAUTIONS

- (a) For the air supply, use clean air fed through a filter.
- (b) Be sure to securely fix the parts which have been moved for adjustment. The typical ones are as follows:
 - o Setscrews of connector pin assembly
 - o Hex socket bolt of span adjustment mechanism
 - o Span adjustment screw
 - o The zero adjustment mechanism employs a lead spring for self locking and it requires no tightening of screws.
- (c) Exercise care not to apply shocks to the magnet unit or apply an unreasonably large force to the magnet unit lever, lest the internal parts should be damaged and the performance be degraded.
- (d) The nozzle position has been critically adjusted at the factory before shipment. Do not change this position. However, when the positional relationship between the flapper and the nozzle has become abnormal, adjust it as follows: Loosen the two clamping-screws of the nozzle block, lightly apply the flapper to the nozzle so that the positioner output pressure becomes equal to the air supply pressure, and fix the nozzle block in this state.

8.2 TROUBLESHOOTING

When the positioner operation has become abnormal, repair it referring to the following table.

Symptom	Probable cause	Remedy
Positioner does not operate in response to input signal.	<ol style="list-style-type: none"> 1. Magnet unit failure 2. Incorrect air supply pressure 3. Wrong electrical connections 	<ol style="list-style-type: none"> 1. Replace the magnet unit. 2. Provide a correct air supply. 3. Refer to Section 4 "EXTERNAL CONNECTIONS."
No output air pressure is delivered.	<ol style="list-style-type: none"> 1. Clogged restriction 2. Incorrect nozzle-flapper positional relationship 3. Incorrect positioning of span adjustment mechanism. 4. Incorrect start point 5. Malfunctioning pilot relay 6. Damaged O-ring of restriction 	<ol style="list-style-type: none"> 1. Remove the restriction from nozzle block of case inside and clean it with a fine wire of 0.2 mm dia. 2. Correct the positional relationship referring to Section 8.1 (d). 3. Refer to Section 5-1, (5). 4. Insufficient compression of zero adjustment screw. Refer to Section 5-1, (4). 5. Replace the pilot relay. 6. Replace the O-ring.
Output air pressure cannot be lowered.	<ol style="list-style-type: none"> 1. Malfunctioning pilot relay 2. Loosening of fixed restriction 3. Stained nozzle-flapper mechanism 	<ol style="list-style-type: none"> 1. Replace the pilot relay. 2. Securely tighten the fixed restriction. 3. Remove the nozzle block and clean the contacting surfaces of nozzle and flapper. After assembly, adjust the positional relationship between nozzle and flapper. Refer to Section 8.1 (d).

(to be cont'd)

Symptom	Probable cause	Remedy
Linearity is poor.	1. Incorrect installation or adjustment	1. Refer to Section 3 "INSTALLATION" and 4 "ADJUSTMENT."
Hysteresis is large.	1. Magnet unit failure 2. Loose screws 3. Incorrect nozzle-flapper positional relationship	1. Replace the magnet unit. 2. Refer to Section 9.1 (b). 3. Correct the positional relationship. Refer to Section 9.1 (d).

SUPPLEMENT (BYPASS MANIFOLD)

This supplement is for the Bypass Manifold which is installed together with the HEP Positioner on a valve actuator. The Bypass Manifold is comprised of an Airset and an air switching mechanism, and allows to select auto (A) position, manual (M) position, and service position. A bypass setup is shown in Fig. 17 and the manifold mechanism is shown in Fig. 18.

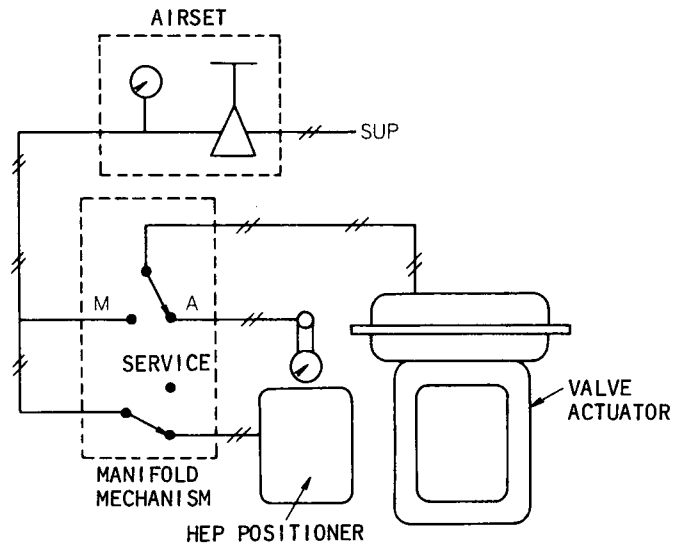

Fig. 17. Bypass Setup

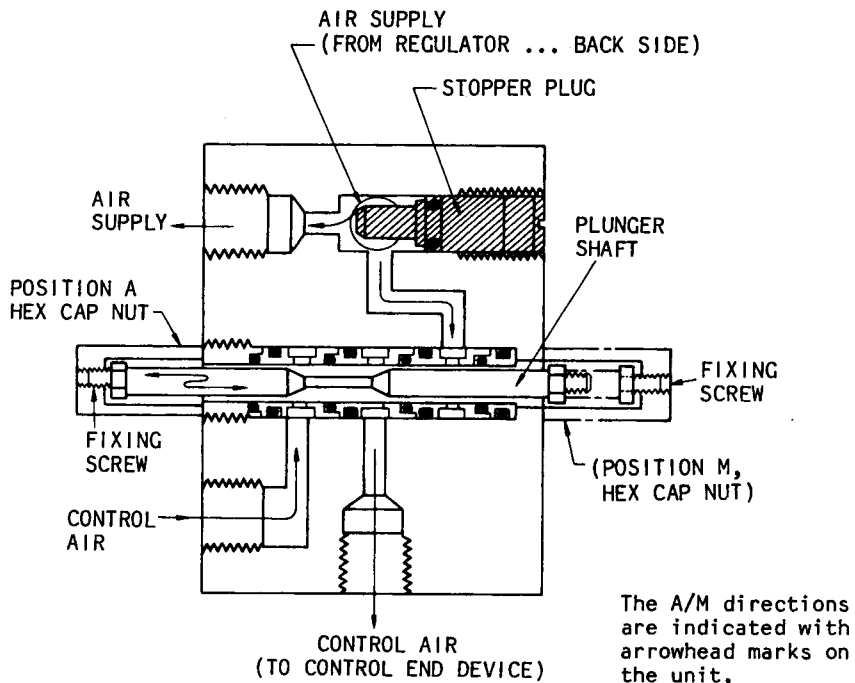

Fig. 18. Bypass Mechanism

Switchover Procedures, and Functions When in Respective States

1. Switchover from Auto (A) to Manual (M)

- (1) Turn counterclockwise the fixing screw at the head of the hex cap nut, using a screwdriver.
- (2) Remove the hex cap nut by turning it counterclockwise.
- (3) Push the plunger shaft into the manifold in the M direction until the shaft hits the stopper.
- (4) Install the hex cap nut at the M position.

When in this state, the HEP Positioner remains idle. The air supply adjusted by turning the knob of the Airset is fed to the actuator, allowing you to manually drive the control valve.

2. Service Position

To set the manifold to this state, from the manual (M) state attained as above, drive the stopper plug into the manifold using the screwdriver, until the plug hits the stopper. The service position basically is of an M state.

When in the service state, the air supply is shut off and the positioner can be dismantled. The control valve, however, can be driven in a manual mode the same as when the manifold is in the M state.

3. Switchover from Manual (M) to AUTO (A)

- (1) Turn counterclockwise the fixing screw at the head of the hex cap nut, using a screwdriver.
- (2) Remove the hex cap nut by turning it counterclockwise.
- (3) Push the plunger shaft into the manifold in the A direction until the shaft hits the stopper.
- (4) Install the hex cap nut at the A position.

When in this state, the actuator is driven automatically by the positioner.

The air supply for the positioner is fed through the Airset. Adjust its output pressure to the required value.

Document Number : OM2-8313-0100
Document Name : CV3000 Series Electro-Pneumatic
Valve Positioners (Single Acting Type)
Model : HEP 15/16/17 User's Manual

Date : Jun. 1998 (Rev. 6) (H)
Issued / Edited by : Yamatake Corporation

YAMATAKE