

SVP3000 Alphaplus Smart Valve Positioner

Model:AVP300/301/302/200/201/202

User's Manual



Yamatake Corporation

Copyright, Notices and Trademarks

Printed in Japan - © 1998-2005 by Yamatake Corporation ALL RIGHTS RESERVED

While this information is presented in good faith and believed to be accurate, Yamatake Corporation disclaims the implied warranties of merchantability and fitness for a particular purpose and makes no express warranties except as may be stated in its written agreement with and for its customer.

In no event shall Yamatake Corporation be liable to anyone for any indirect, special or consequential damages. This information and specifications in this document are subject to change without notice.

HART is registered trademark of the HART Communication Foundation.

Thank you for purchasing the Yamatake SVP3000 Alphaplus model AVP300/301/302/200/201/202 Smart Valve Positioner.

The SVP3000 Alphaplus (also referred to as SVP in this manual) is an intelligent valve positioner that can be connected to a 4-20 mA signal line. Since all adjustments can be performed electrically using the Smart Field Communicator (SFC), or HART communicator model 275 the relationship between the input signal and the position of the control valve can be set arbitrarily. Split range and other special settings are also easy to set up.

This user's manual describes the use of the SVP3000 Alphaplus. Use this manual to get the most from the features of this product.

Safety

About this manual

This manual contains information and warnings that must be observed to keep the SVP3000 Alphaplus Smart Valve Positioner (SVP) operating safely. Correct installation, correct operation and regular maintenance are essential to ensure safety while using this device.

For the correct and safe use of this device it is essential that both operating and service personnel follow generally accepted safety procedures in addition to the safety precautions specified in this manual.

The following symbols are used in this manual to alert you to possible hazards:

WARNING

Denotes a potentially hazardous situation which, if not avoided, could result in death or serious injury.

CAUTION

Denotes a potentially hazardous situation which, if not avoided, could result in operator minor injury or damage to device.

~Note Information that can be useful to the user.

Safety precautions

WARNING

- ELECTRICAL SHOCK HAZARD! Turn off power before performing any wiring.
- NEVER open the terminal box cover while the SVP is energized in a hazardous environment.
- Do not unnecessarily touch the SVP while it is in operation. The surface can be very hot or very cold, depending on the operating environment.

CAUTION

Do not stand on the installed SVP or use it as a step. You can damage the unit.

Explosion-protected models

JIS Flameproof apparatus

$$\text{Ex d } \frac{\text{IIC}}{1} \frac{\text{T6}}{2}$$

1: Explosive gas atmosphere classified in IIC

2: Gas atmosphere of which ignition temperature is 85°C or greater

Ambient temperature: -20°C to +55°C

WARNING

Do not open the terminal cover while the SVP is in operation and/or at least for one minute after it is turned off. Do not open the terminal cover nor loosen the screws that fasten the angle sensor to the SVP unit. Doing so may cause ignition of the explosive atmosphere.

WARNING

Cable gland must be placed in the signal wire entry of the apparatus. Use the attached cable gland. When necessary, change the wiring direction, and use the attached elbow. No other elbow may be used. No other elbow can ensure the intended explosion-protection.

The specified type of protection cannot be guaranteed if any of the above precautions are ignored.

Prevent corrosion, deformation or damage to the housing or the terminal box cover. Screw the cover-fastening screw tightly. Do not open the cover while the apparatus is in operation.

FM Explosionproof / Dust-ignitionproof apparatus (in accordance with NEC)

⚠ CAUTION

- Install the apparatus only in hazardous (classified) locations for which the apparatus has been approved.
- Seal each conduit entering the apparatus enclosure within 18 inches (457 mm) from the enclosure.
- Do not open the apparatus enclosure when an explosive atmosphere is present.

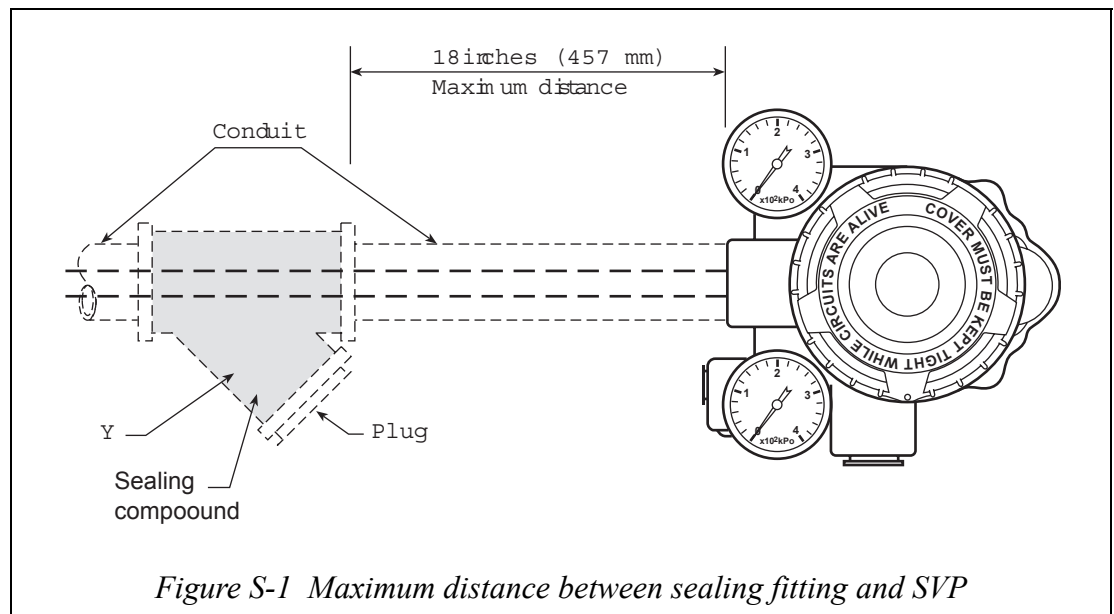

1. Class I, Division 1 locations

1.1 Wiring methods

- Threaded rigid metal conduit, threaded steel intermediate metal conduit, or Type MI cable with termination fittings approved for the location, can be employed
- Threaded joints must be made up with at least five threads fully engaged.

1.2 Sealing

- Each conduit entering the apparatus enclosure is required to be sealed within 18 inches {457 mm} from the enclosure.
- The sealing of each conduit can be provided with a sealing fitting approved for class I locations.
- Sealing compound must be approved and does not have a melting point of less than 93°C {200°F}.
- The minimum thickness of the sealing compound is not less than the trade size of the conduit and, in no case, less than 5/8 inch {16 mm}.
- Splices and taps cannot be made in the fitting.

2. Class I, Division 2 locations

2.1 Wiring methods

Threaded rigid metal conduit, threaded steel intermediate metal conduit, enclosed gasketed busways, or Type PLTC cable in accordance with the provisions of remote-control, signaling, and power-limited circuits (see NEC, Article 725), or Type ITC cable in cable trays, in raceways, supported by messenger wire, or directly buried where the cable is listed for this use; Type MI, MC, MV, or TC cable with approved termination fittings can be employed.

2.2 Sealing

Each conduit entering the apparatus enclosure is required to be sealed as shown in “1.2 Sealing”.

3. Class II, Division 1 locations

3.1 Wiring methods

Threaded rigid metal conduit, threaded steel intermediate metal conduit, or Type MI cable with termination fittings approved for the location, can be employed.

3.2 Sealing

- Where a raceway provides communication between the apparatus enclosure and an enclosure that is not required to be dust-ignitionproof, sealing means must be provided to prevent the entrance of dust into the dust-ignitionproof enclosure through the raceway. One of the following means can be used: (1) a permanent and effective seal; (2) a horizontal raceway not less than 10 ft {3.05 m} long; or (3) a vertical raceway not less than 5 ft {1.52 m} long and extending downward from the dust-ignitionproof enclosure.
- Seals are not required to be explosionproof.

4. Class II, Division 2 locations

4.1 Wiring methods

Rigid metal conduit, intermediate metal conduit, electrical metallic tubing, dusttight wireways, or Type MC or MI cable with approved termination fittings, or Type PLTC in cable trays, or Type ITC in cable trays, or Type MC or TC cable installed in ladder, ventilated trough, or ventilated channel cable trays in a single layer, with a space not less than the larger cable diameter between the two adjacent cables, can be employed.

4.2 Sealing

Sealing means must be provided as shown in “3.2 Sealing”.

5. Class III, Division 1 locations**5.1 Wiring methods**

Rigid metal conduit, rigid non-metallic conduit, intermediate metal conduit, electrical metallic tubing, dusttight wireways, or Type MC or MI cable with approved termination fittings, can be employed.

5.2 Sealing

Sealing means are not required.

6. Class III, Division 2 locations**6.1 Wiring methods**

Wiring methods must comply with “5.1 Wiring methods”.

6.2 Sealing

Sealing means are not required.

FM intrinsically safe apparatus (in accordance with NEC)

CAUTION

- Only suitable associated apparatus separately approved by FM (FMRC) shall be connected to the intrinsically safe apparatus.
- Electrical equipment connected to the associated apparatus in non-hazardous locations shall not use or generate more than 250 Vrms.
- Tampering and replacement of any components within the intrinsically safe apparatus with non-factory components may adversely affect the safe use of the system.

Installation requirements

1. The intrinsically safe and associated apparatus shall be installed in accordance with the control drawing(s) attached.

Especially, the control drawing(s) provides guidance on determining the maximum allowed capacitance and inductance of the interconnecting cables.

2. The intrinsically safe apparatus is permitted to be installed in any hazardous (classified) location for which it has been approved, by using any of the wiring methods suitable for ordinary (unclassified) locations, including wiring methods for communication systems.
3. Conductors of the intrinsically safe circuit shall not be placed in raceways, cable trays, or cables with conductors of any non-intrinsically safe circuit, unless (1) the conductors of the intrinsically safe circuit are separated from the conductors of non-intrinsically safe circuits by a distance of at least 50 mm and secured, or separated by a grounded partition or an approved insulating partition; or (2) either all of the intrinsically safe circuit conductors or all of the non-intrinsically safe circuit conductors are in grounded metal-sheathed or metal-clad cables where the sheathing or cladding is capable of carrying fault current to ground.
4. Different intrinsically safe circuits shall be in separate cables, unless (1) the conductors of each circuit are within a grounded metal shield, or (2) the conductors of each circuit have insulation with a minimum thickness of 0.01 inch {0.25 mm}.
5. Intrinsically safe apparatus, associated apparatus, shields of conductors or cables, enclosures and raceways, if of metal, shall be grounded.
6. If the associated apparatus is a type of shunt diode barriers, supplementary bonding to the grounding electrode is needed. And the grounding path resistance from the farthest barrier to the grounding electrode shall not exceed 1Ω.

In practice, the bonding to the grounding electrode is achieved by connecting the grounding terminals of the barriers to the intrinsically safe ground bus which is connected to the grounding electrode with an insulated conductor not smaller than No.12 AWG (2.05 mm in dia.).

7. In hazardous locations, non-current-carrying metal parts of the apparatus, raceways, and other enclosures of the intrinsically safe system shall be bonded to ensure the electrical continuity.
8. In non-hazardous locations, where metal raceways are used for the intrinsically safe system wiring in hazardous locations, all intervening raceways, fittings,

boxes, enclosures, etc. between the hazardous locations and the point of grounding for the power supply system or point of grounding of a separately derived system, shall be grounded by using bonding jumpers with proper fittings or other approved means of bonding.

9. Where conduits and cables are used to protect the intrinsically safe wiring against environments, the conduits and cables must be sealed so that they do not transmit gases, vapors, or dust from a hazardous location to a non-hazardous location. Sealing fittings should be installed in each conduit run leaving the hazardous location, on either side of the boundary within 10 ft {3.05 m} of the boundary. Such seals need not be explosionproof.
10. The grounding electrode usually available on premises is specified in a), b), c) or d):
 - a) Metal underground water pipe in direct contact with the earth for 10 ft {3.05 m} or more.
 - b) Metal frame of the building, where effectively grounded.
 - c) Concrete-encased electrode. An electrode encased by at least 2 inches {50.8 mm} of concrete, located within and near the bottom of a concrete foundation or footing that is in direct contact with the earth, consisting of at least 20 ft {6.1m} of one or more bare or zinc galvanized or other electrically conductive coated steel reinforcing bars or rods not less than 1/2 inch {12.7 mm} diameter, or consisting of at least 20 ft {6.1 m} of bare copper conductor not smaller than No.2 AWG (6.54 mm in dia.).
 - d) Ground ring. A ground ring encircling the building or structure, in direct contact with the earth at a depth below earth surface not less than 2 1/2 ft {762 mm}, consisting of at least 20 ft {6.1 m} of bare copper conductor not smaller than No.2 AWG.

Where none of the above electrodes is available, made electrodes should be used:

- e) Rod and pipe electrodes. Not less than 8 ft {2.44 m} in length, consisting of the following materials, and being installed in the following manner:
 - Electrodes of pipe or conduit shall not be smaller than 3/4 inch trade size and, where of iron or steel, shall have the outer surface galvanized or otherwise metalcoated for corrosion protection.
 - Electrodes of rods of iron or steel shall be at least 5/8 inch {15.87 mm} in diameter. Stainless steel rods less than 5/8 inch {15.87 mm} in diameter, nonferrous rods, or their equivalent shall not be less than 1/2 inch {12.7 mm} in diameter.
 - The electrode shall be installed such that at least 8 ft {2.44 m} of length is in contact with the soil. It shall be driven to a depth of not less than 8 ft {2.44 m}.
- f) Plate electrodes. Each plate electrode shall expose not less than 2 sq ft {0.186 sq m} of surface to exterior soil. Electrodes of iron or steel plates shall be at least 1/4 inch {6.35 mm} in thickness. Electrodes of non-ferrous metal shall be at least 0.06 inch {1.52 mm} in thickness.

A single electrode consisting of a rod, pipe, or plate that does not have a resistance to ground of 25Ω or less shall be augmented by one additional electrode of any of the types specified in a) to f). Where multiple rod, pipe, or plate electrodes are installed, they shall not be less than 6 ft {1.83 m} apart.

Control drawings for FM intrinsically safe

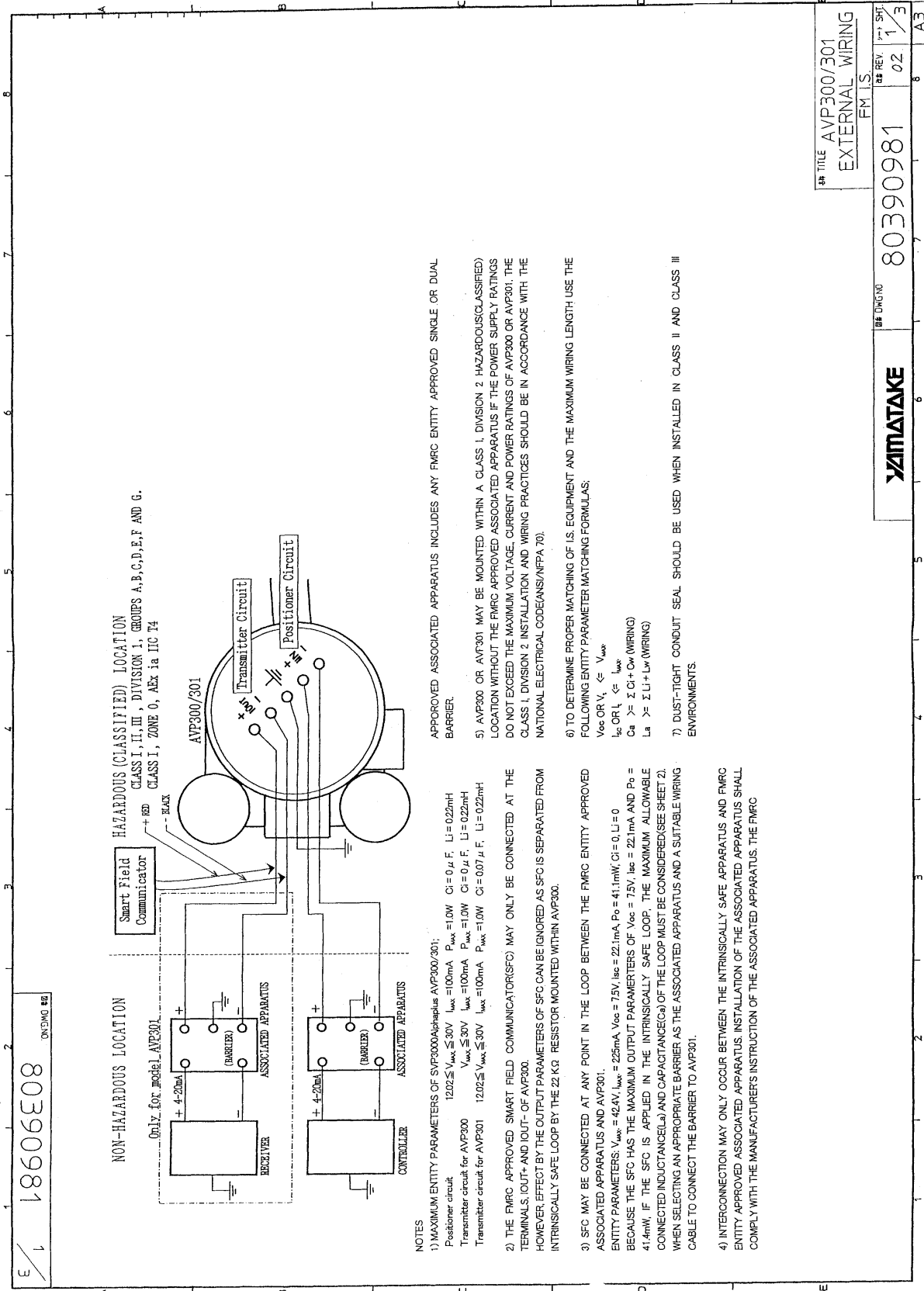

1 80390981 18606E08 ONENING 88

HAZARDOUS (CLASSIFIED) LOCATION
CLASS I, II, III, DIVISION 1, GROUPS A, B, C, D, E, F AND G.
CLASS I, ZONE 0, AEx ia IIC T4

NON-HAZARDOUS LOCATION
Only for model AVP301

- NOTES
- 1) MAXIMUM ENTITY PARAMETERS OF SVP3000Alphaplus AVP300/301:
Positioner circuit $V_{max} \leq 30V$, $I_{max} = 100mA$, $P_{max} = 1.0W$, $C_i = 0.4 \mu F$, $L_i = 0.22mH$
Transmitter circuit for AVP300 $V_{max} \leq 30V$, $I_{max} = 100mA$, $P_{max} = 1.0W$, $C_i = 0.4 \mu F$, $L_i = 0.22mH$
Transmitter circuit for AVP301 $V_{max} \leq 30V$, $I_{max} = 100mA$, $P_{max} = 1.0W$, $C_i = 0.07 \mu F$, $L_i = 0.22mH$
 - 2) THE FMRC APPROVED SMART FIELD COMMUNICATOR(SFC) MAY ONLY BE CONNECTED AT THE TERMINALS, IOUT- AND IOUT+ OF AVP300. HOWEVER EFFECT BY THE OUTPUT PARAMETERS OF SFC CAN BE IGNORED AS SFC IS SEPARATED FROM INTRINSICALLY SAFE LOOP BY THE 22 KΩ RESISTOR MOUNTED WITHIN AVP300.
 - 3) SFC MAY BE CONNECTED AT ANY POINT IN THE LOOP BETWEEN THE FMRC ENTITY APPROVED ASSOCIATED APPARATUS AND AVP301.
ENTITY PARAMETERS: $V_{max} = 42.4V$, $I_{max} = 225mA$, $V_{oc} = 7.5V$, $I_{sc} = 22.1mA$, $P_o = 41.1mW$, $C_i = 0$, $L_i = 0$
BECAUSE THE SFC HAS THE MAXIMUM OUTPUT PARAMETERS OF $V_{oc} = 7.5V$, $I_{sc} = 22.1mA$ AND $P_o = 41.1mW$, IF THE SFC IS APPLIED IN THE INTRINSICALLY SAFE LOOP, THE MAXIMUM ALLOWABLE CONNECTED INDUCTANCE(Li) AND CAPACITANCE(Ci) OF THE LOOP MUST BE CONSIDERED(SEE SHEET Z). WHEN SELECTING AN APPROPRIATE BARRIER AS THE ASSOCIATED APPARATUS AND A SUITABLE WIRING CABLE TO CONNECT THE BARRIER TO AVP301.
 - 4) INTERCONNECTION MAY ONLY OCCUR BETWEEN THE INTRINSICALLY SAFE APPARATUS AND FMRC ENTITY APPROVED ASSOCIATED APPARATUS. INSTALLATION OF THE ASSOCIATED APPARATUS SHALL COMPLY WITH THE MANUFACTURER'S INSTRUCTION OF THE ASSOCIATED APPARATUS. THE FMRC APPROVED ASSOCIATED APPARATUS INCLUDES ANY FMRC ENTITY APPROVED SINGLE OR DUAL BARRIER.
 - 5) AVP300 OR AVP301 MAY BE MOUNTED WITHIN A CLASS I, DIVISION 2 HAZARDOUS(CLASSIFIED) LOCATION WITHOUT THE FMRC APPROVED ASSOCIATED APPARATUS IF THE POWER SUPPLY RATINGS DO NOT EXCEED THE MAXIMUM VOLTAGE, CURRENT AND POWER RATINGS OF AVP300 OR AVP301. THE CLASS I, DIVISION 2 INSTALLATION AND WIRING PRACTICES SHOULD BE IN ACCORDANCE WITH THE NATIONAL ELECTRICAL CODE(ANSI/NFPA 70).
 - 6) TO DETERMINE PROPER MATCHING OF I.S. EQUIPMENT AND THE MAXIMUM WIRING LENGTH, USE THE FOLLOWING ENTITY PARAMETER MATCHING FORMULAS:
 $V_{oc} OR V_i \leq V_{max}$
 $I_{sc} OR I_i \leq I_{max}$
 $C_a \geq \sum C_i + C_w$ (WIRING)
 $L_a \geq \sum L_i + L_w$ (WIRING)
 - 7) DUST-TIGHT CONDUIT SEAL SHOULD BE USED WHEN INSTALLED IN CLASS II AND CLASS III ENVIRONMENTS.

TITLE AVP300/301
EXTERNAL WIRING
FM I.S.
REV 1 1/3
02

80390981

YAMATAKE

DESIGN

A3

2 / 80390981
 DWS/MG 849

- 8) INTRINSIC SAFE INSTALLATION SHOULD BE IN ACCORDANCE WITH ANSI/ISA RPT2.8 "INSTALLATION OF INTRINSICALLY SAFE SYSTEMS FOR HAZARDOUS(CLASSIFIED) LOCATIONS" AND THE NATIONAL ELECTRICAL CODE(ANSI/NFPA 70).
- 9) INSTALLATION OF ALL FMRC APPROVED DEVICES SHALL BE IN ACCORDANCE TO THE MANUFACTURER'S INSTALLATION DRAWINGS WHEN INSTALLING THE EQUIPMENT.
- 10) EX. 2 IS SUITABLE ONLY FOR CLASS I, ZONE 1, HAZARDOUS(CLASSIFIED) LOCATIONS AND NOT SUITABLE FOR CLASS I, ZONE 0, AND CLASS I, DIVISION 1 HAZARDOUS(CLASSIFIED) LOCATIONS.

**CONSIDERATION OF AN INTRINSICALLY SAFE LOOP
 BASED ON ENTITY PARAMETERS**

THE ENTITY CONCEPT ALLOWS INTERCONNECTION OF INTRINSICALLY SAFE APPARATUS TO ASSOCIATED APPARATUS NOT SPECIFICALLY EXAMINED IN SUCH COMBINATION.

BASICALLY, THE MAXIMUM UNPROTECTED CAPACITANCE(C) AND INDUCTANCE(L) OF THE INTRINSICALLY SAFE APPARATUS, INCLUDING INTERCONNECTING WIRING PARAMETERS(L_w, C_w), MUST BE EQUAL OR LESS THAN THE CAPACITANCE(C_a) AND INDUCTANCE(L_a) WHICH CAN BE SAFELY CONNECTED TO THE ASSOCIATED APPARATUS. ALSO, THE MAXIMUM OUTPUT PARAMETERS(V_{oc}, I_{sc}, P_o) OF THE ASSOCIATED APPARATUS MUST BE EQUAL OR LESS THAN THE MAXIMUM ENTITY PARAMETERS(V_{max}, I_{max}, P_{max}) OF THE INTRINSICALLY SAFE APPARATUS.

IF THE SFC IS CONNECTED TO THE INTRINSICALLY SAFE LOOP, FURTHER CONSIDERATION MUST BE TAKEN AS SHOWN BY THE FOLLOWING EXAMPLES.

EXAMPLE 1. L_a FOR POSITIONER LOOP
 MAXIMUM OUTPUT CURRENT(I_{scum}) TO THE LOOP IN THE WORST SITUATION IS THE DELIVERED CURRENT(I_{sc0}) BY THE BARRIER.

IF I_{sc0} OF THE BARRIER IS 93mA, I_{scum} = 89mA.
 THEN, BY APPLYING 100mA AT THE NEXT HIGHER VALUE OF THE RESULTING I_{scum} TO THE RIGHT TABLE, L_a FOR GROUP A/B IS DETERMINED : L_a = 400mH.

THE ABOVE OBTAINED L_a VALUE MUST SATISFY THE BELOW RELATIONSHIP.
 $L_a \geq L_l$ (POSITIONER) + L_w (WIRING)

ACCORDINGLY, THE WIRING INDUCTANCE EXCEEDS THE VALUE L_a - L_l (POSITIONER), i.e.
 IF L_l OF POSITIONER CIRCUIT IS 0.22mH,
 $L_w \leq 2.50mH - 0.22mH = 2.28mH$.

NOTE : IF THE ABOVE L_w VALUE IS SMALLER THAN THE INDUCTANCE OF A CABLE, ANOTHER BARRIER WITH A SMALLER I_{sc} VALUE SHOULD BE SELECTED.

EXAMPLE 2. C_a FOR POSITIONER LOOP
 MAXIMUM OUTPUT VOLTAGE(V_{scum}) TO THE LOOP IN THE WORST SITUATION IS THE DELIVERED VOLTAGE(V_{sc0}) BY THE BARRIER.
 IF V_{sc0} OF THE BARRIER IS 28V, V_{scum} = 28V.
 THEN, BY APPLYING 28V TO THE RIGHT TABLE, C_a FOR GROUP A/B IS DETERMINED : C_a = 0.14 μF.
 THE ABOVE OBTAINED C_a VALUE MUST SATISFY THE BELOW RELATIONSHIP.

$C_a \geq C_l$ (POSITIONER) + C_w (WIRING)
 ACCORDINGLY, THE WIRING CAPACITANCE NEVER EXCEEDS THE VALUE C_a - C_l (POSITIONER), i.e.
 IF C_l OF POSITIONER CIRCUIT IS 0.04 μF,
 $C_w \leq 0.14 \mu F - 0.04 \mu F = 0.10 \mu F$.

NOTE : IF THE ABOVE C_w VALUE IS SMALLER THAN THE CAPACITANCE OF A CABLE, ANOTHER BARRIER WITH A SMALLER V_{sc} VALUE SHOULD BE SELECTED.

I _{scum} (mA)	A/B	C	D	V _{scum} (V)	A/B	C	D
20	9000	33000	70000	5	91.97	275.91	735.77
30	4000	15000	31240	10	3.21	9.84	25.68
40	2300	8700	17630	15	0.78	2.35	6.26
50	1500	5600	11310	20	0.34	1.01	2.70
60	1000	4000	7870	22	0.26	0.78	2.09
70	750	2800	5740	24	0.21	0.63	1.67
80	600	2200	4440	26	0.17	0.51	1.37
90	500	1800	3570	28	0.14	0.43	1.14
100	400	1500	2850	30	0.12	0.36	0.97
110	300	1200	2360	32	0.11	0.32	0.84
120	250	1000	1980	34	0.09	0.28	0.73
130	200	900	1690	36	0.08	0.24	0.65
140	180	800	1460	38	0.08	0.22	0.58
150	130	700	1270	40	0.06	0.19	0.52
160	100	620	1120	42	0.06	0.18	0.47
170	0.80	550	990				
180	0.60	500	880				
200	0.50	400	720				
220	0.40	320	590				

8: TITLE AVP300/301
 EXTERNAL WIRING
 FM I.S.
 8: REV. 1-1 SHT
 02

8: DWG NO 80390981
YAMATAKE

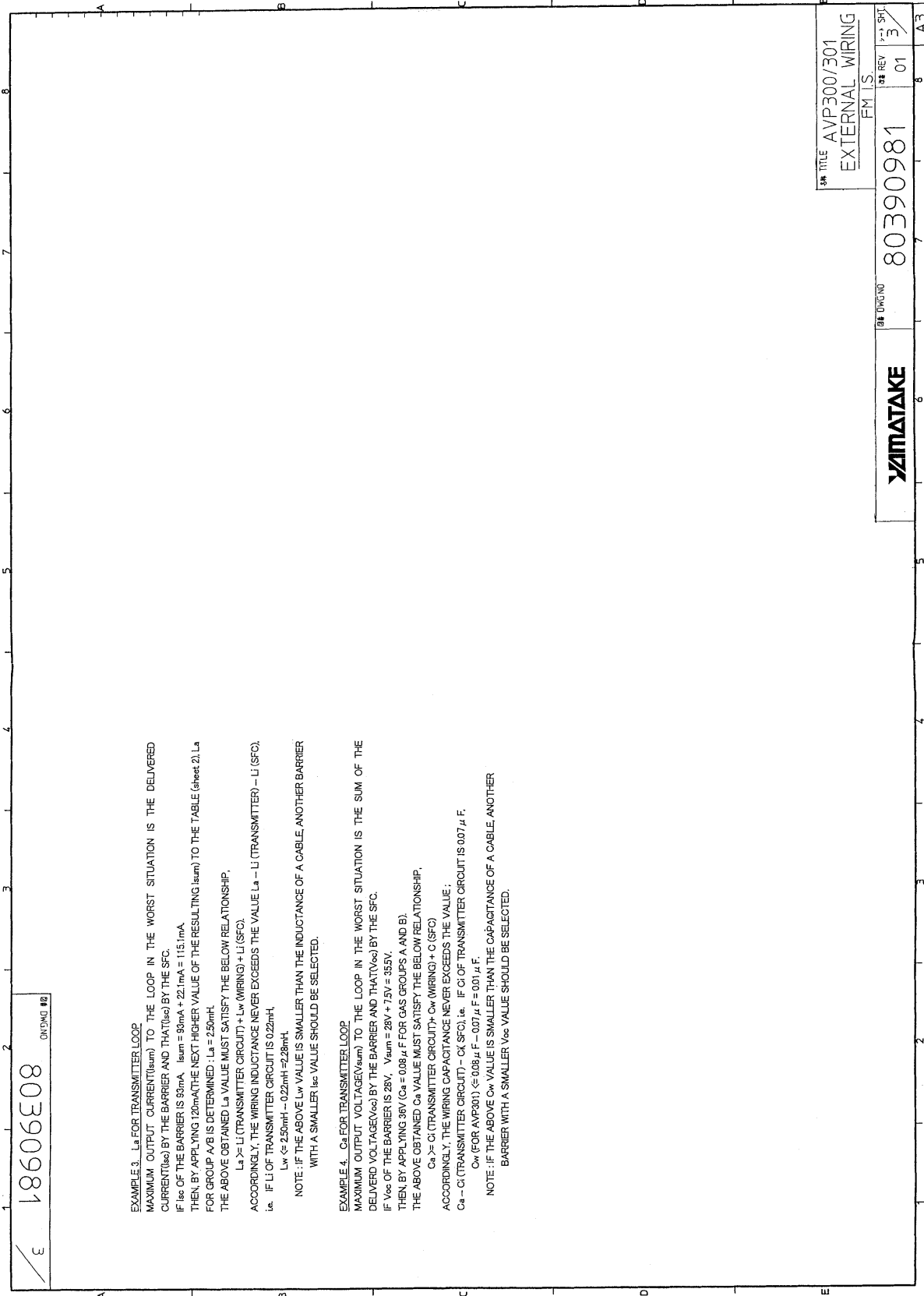

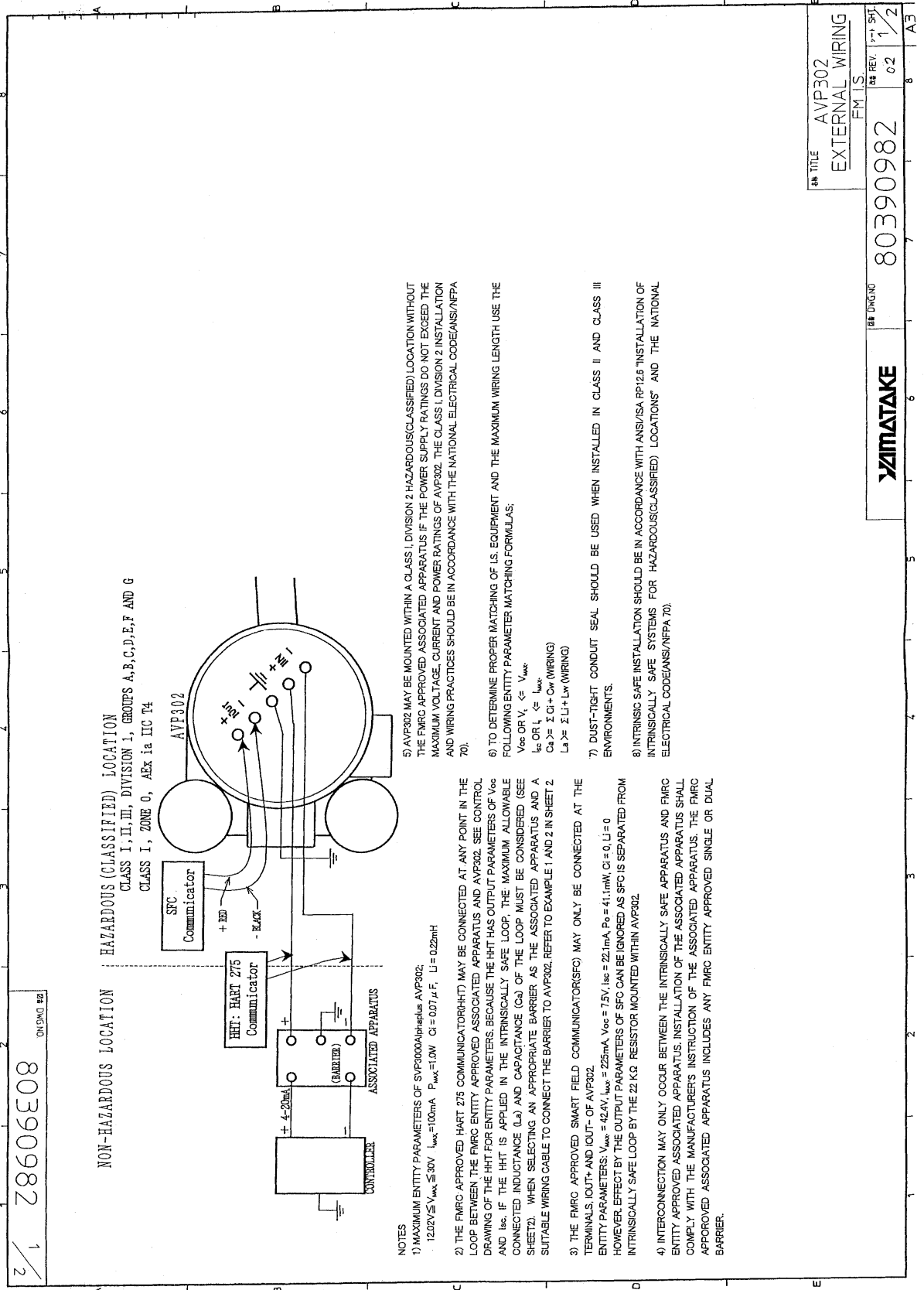

80390982 1/2
ONG DNG 828

- NOTES
- 1) MAXIMUM ENTITY PARAMETERS OF SVP3000Alphasplus AVP302:
 $12.02V \leq V_{max} \leq 30V$, $I_{max} = 100mA$, $P_{max} = 1.0W$, $C_i = 0.07 \mu F$, $L_i = 0.22mH$
 - 2) THE FMRC APPROVED HART 275 COMMUNICATOR(HHT) MAY BE CONNECTED AT ANY POINT IN THE LOOP BETWEEN THE FMRC ENTITY APPROVED ASSOCIATED APPARATUS AND AVP302. SEE CONTROL DRAWING OF THE HHT FOR ENTITY PARAMETERS. BECAUSE THE HHT HAS OUTPUT PARAMETERS OF V_{oc} AND I_{sc} , IF THE HHT IS APPLIED IN THE INTRINSICALLY SAFE LOOP, THE MAXIMUM ALLOWABLE CONNECTED INDUCTANCE (L_a) AND CAPACITANCE (C_a) OF THE LOOP MUST BE CONSIDERED (SEE SHEET2). WHEN SELECTING AN APPROPRIATE BARRIER AS THE ASSOCIATED APPARATUS AND A SUITABLE WIRING CABLE TO CONNECT THE BARRIER TO AVP302, REFER TO EXAMPLE 1 AND 2 IN SHEET 2.
 - 3) THE FMRC APPROVED SMART FIELD COMMUNICATOR(SFC) MAY ONLY BE CONNECTED AT THE TERMINALS IOUT+ AND IOUT- OF AVP302.
 ENTITY PARAMETERS: $V_{max} = 42.4V$, $I_{max} = 225mA$, $V_{oc} = 7.5V$, $I_{sc} = 22.1mA$, $P_o = 41.1mW$, $C_i = 0$, $L_i = 0$
 HOWEVER, EFFECT BY THE OUTPUT PARAMETERS OF SFC CAN BE IGNORED AS SFC IS SEPARATED FROM INTRINSICALLY SAFE LOOP BY THE 22 K Ω RESISTOR MOUNTED WITHIN AVP302.
 - 4) INTERCONNECTION MAY ONLY OCCUR BETWEEN THE INTRINSICALLY SAFE APPARATUS AND FMRC ENTITY APPROVED ASSOCIATED APPARATUS. INSTALLATION OF THE ASSOCIATED APPARATUS SHALL COMPLY WITH THE MANUFACTURER'S INSTRUCTION OF THE ASSOCIATED APPARATUS. THE FMRC APPROVED ASSOCIATED APPARATUS INCLUDES ANY FMRC ENTITY APPROVED SINGLE OR DUAL BARRIER.
 - 5) AVP302 MAY BE MOUNTED WITHIN A CLASS I, DIVISION 2 HAZARDOUS(GCLASSIFIED) LOCATION WITHOUT THE FMRC APPROVED ASSOCIATED APPARATUS IF THE POWER SUPPLY RATINGS DO NOT EXCEED THE MAXIMUM VOLTAGE, CURRENT AND POWER RATINGS OF AVP302. THE CLASS I, DIVISION 2 INSTALLATION AND WIRING PRACTICES SHOULD BE IN ACCORDANCE WITH THE NATIONAL ELECTRICAL CODE(ANSI/NFPA 70).
 - 6) TO DETERMINE PROPER MATCHING OF IS EQUIPMENT AND THE MAXIMUM WIRING LENGTH USE THE FOLLOWING ENTITY PARAMETER MATCHING FORMULAS:
 V_{oc} OR $V_i \leq V_{max}$
 I_{sc} OR $I_i \leq I_{max}$
 $C_a \geq \Sigma C_i + C_w$ (WIRING)
 $L_a \geq \Sigma L_i + L_w$ (WIRING)
 - 7) DUST-TIGHT CONDUIT SEAL SHOULD BE USED WHEN INSTALLED IN CLASS II AND CLASS III ENVIRONMENTS.
 - 8) INTRINSIC SAFE INSTALLATION SHOULD BE IN ACCORDANCE WITH ANSI/ISA RP12.6 "INSTALLATION OF INTRINSICALLY SAFE SYSTEMS FOR HAZARDOUS(GCLASSIFIED) LOCATIONS" AND THE NATIONAL ELECTRICAL CODE(ANSI/NFPA 70).

8th TITLE AVP302
EXTERNAL WIRING
FM I.S.
REV. 02 1/2

80390982
YAMATAKE
ONG DNG 828

2 80390982 DRAWING NO

- 9) INSTALLATION OF ALL FMRC APPROVED DEVICES SHALL BE IN ACCORDANCE TO THE MANUFACTURER'S INSTALLATION DRAWINGS WHEN INSTALLING THE EQUIPMENT.
- 10) THE MAXIMUM CABLE CAPACITANCE(Ca) AND THE MAXIMUM CABLE INDUCTANCE(La) OF THE CONNECTION BETWEEN SFC AND AVP302 ARE AS FOLLOWS:
- | GAS GROUPS | Ca(μF) | La(mH) |
|------------|--------|--------|
| A/B | 10.49 | 68.06 |
| C/D | 31.46 | 254.01 |
| E/F/G | 83.89 | 569.72 |
- 11) AEX-1b IS SUITABLE ONLY FOR CLASS I, ZONE 1, HAZARDOUS(CLASSIFIED) LOCATIONS AND NOT SUITABLE FOR CLASS I, ZONE 0 AND CLASS I, DIVISION 1 HAZARDOUS(CLASSIFIED) LOCATIONS.

CONSIDERATION OF AN INTRINSICALLY SAFE LOOP
BASED ON ENTITY PARAMETERS

THE ENTITY CONCEPT ALLOWS INTERCONNECTION OF INTRINSICALLY SAFE APPARATUS TO ASSOCIATED APPARATUS NOT SPECIFICALLY EXAMINED IN SUCH COMBINATION.

BASICALLY, THE MAXIMUM UNPROTECTED CAPACITANCE(C) AND INDUCTANCE(L) OF THE INTRINSICALLY SAFE APPARATUS, INCLUDING INTERCONNECTING WIRING PARAMETERS(Lw, Cw), MUST BE EQUAL OR LESS THAN THE CAPACITANCE(Ca) AND INDUCTANCE(La) WHICH CAN BE SAFELY CONNECTED TO THE ASSOCIATED APPARATUS. ALSO, THE MAXIMUM OUTPUT PARAMETERS(Voc, Isc, Po) OF THE ASSOCIATED APPARATUS MUST BE EQUAL OR LESS THAN THE MAXIMUM ENTITY PARAMETERS(Voc_max, P_max) OF THE INTRINSICALLY SAFE APPARATUS.

IF THE HART 275 COMMUNICATOR(HHT) IS CONNECTED TO THE INTRINSICALLY SAFE LOOP, FURTHER CONSIDERATION MUST BE TAKEN AS SHOWN BY THE FOLLOWING EXAMPLES.

EXAMPLE 1. La
MAXIMUM OUTPUT CURRENT(Isum) TO THE LOOP IN THE WORST SITUATION IS THE SUM OF THE DELIVERED CURRENT(Isc) BY THE BARRIER AND THAT(Isc) BY HHT.
IF Isc OF THE BARRIER IS 93mA AND Isc OF HHT IS 32mA, Isum = 93mA + 32mA = 125mA.
THEN, BY APPLYING 100mA AT THE NEXT HIGHER VALUE OF THE RESULTING Isum TO THE RIGHT TABLE, La FOR GROUP A/B IS DETERMINED : La = 2.00mH.

La >= LI (AVP302) + Lw (WIRING) + LI (HHT)

ACCORDINGLY, THE WIRING INDUCTANCE EXCEEDS THE VALUE La - LI (AVP302) - LI (HHT), i.e. IF LI OF AVP302 IS 0.22mH AND LI OF HHT IS 0mH, Lw < 2.00mH - 0.22mH - 0mH = 1.78mH.

NOTE : IF THE ABOVE Lw VALUE IS SMALLER THAN THE INDUCTANCE OF A CABLE, ANOTHER BARRIER WITH A SMALLER Isc VALUE SHOULD BE SELECTED.

EXAMPLE 2. Ca
MAXIMUM OUTPUT VOLTAGE(Vsum) TO THE LOOP IN THE WORST SITUATION IS THE SUM OF THE DELIVERED VOLTAGE(Voc) BY THE BARRIER AND THAT(Voc) BY HHT.
IF Voc OF THE BARRIER IS 28V AND Voc OF HHT IS 1.7V, Vsum = 28V + 1.7V = 29.7V.
THEN, BY APPLYING 30V AT THE NEXT HIGHER VALUE OF THE RESULTING Vsum TO THE RIGHT TABLE, Ca FOR GROUP A/B IS DETERMINED. Ca = 0.12 μF.

Ca >= CI (AVP302) + Cw (WIRING) + CI (HHT)

THE ABOVE OBTAINED Ca VALUE MUST SATISFY THE BELOW RELATIONSHIP.
ACCORDINGLY, THE WIRING CAPACITANCE NEVER EXCEED THE VALUE Ca - CI (AVP302) - CI (HHT), i.e. IF CI OF AVP302 IS 0.07 μF AND CI OF HHT IS 0 μF,
Cw <= 0.12 μF - 0.07 μF = 0.05 μF.

NOTE : IF THE ABOVE Cw VALUE IS SMALLER THAN THE CAPACITANCE OF A CABLE, ANOTHER BARRIER WITH A SMALLER Voc VALUE SHOULD BE SELECTED.

Isum	La(mH)	Vsum			Ca(μF)		
		(mA)	A/B	C	D	(V)	A/B
20	90.00	330.00	700.00	5	91.97	275.91	735.77
30	40.00	150.00	312.40	10	3.21	9.64	28.89
40	23.00	87.00	176.30	15	0.78	2.35	6.26
50	15.00	56.00	113.10	20	0.34	1.01	2.70
60	10.00	40.00	78.70	22	0.26	0.78	2.09
70	7.50	28.00	57.90	24	0.21	0.63	1.67
80	6.00	22.00	44.40	26	0.17	0.51	1.37
90	5.00	18.00	35.10	28	0.14	0.43	1.14
100	4.00	15.00	28.50	30	0.12	0.36	0.97
110	3.00	12.00	23.60	32	0.11	0.32	0.84
120	2.50	10.00	19.80	34	0.09	0.28	0.73
130	2.00	8.00	16.90	36	0.08	0.24	0.65
140	1.60	6.00	14.60	38	0.08	0.22	0.58
150	1.30	5.00	12.70	40	0.06	0.19	0.52
160	1.00	4.00	11.20	42	0.06	0.18	0.47
170	0.80	3.50	9.90				
180	0.60	3.00	8.80				
200	0.50	2.50	7.20				
220	0.40	2.00	5.90				

TITLE AVP302
EXTERNAL WIRING
F.M.I.S.
REV 02
SHT 2
8

80390982
DRAWING NO
YAMATAKE

FM/CSA nonincendive apparatus

CAUTION

- The nonincendive apparatus can be installed only in Division 2 hazardous (classified) locations for which the apparatus has been approved.
- Tampering and replacement of any components within the nonincendive apparatus may impair safe use of the apparatus.

Installation requirements

1. Wiring of the nonincendive circuit is permitted using any of the methods suitable for wiring in ordinary (unclassified) locations.
- ~Note** *Nonincendive apparatus is composed of all nonincendive circuits in which any arc or thermal effect produced under normal operating conditions of the apparatus is not capable of igniting the explosive atmospheres. This protection technique is permitted for apparatus in those Class I, Division 2, Class II, Division 2, and Class III locations. Nonincendive apparatus looks like intrinsically safe apparatus but does not require associated apparatus, for example, shunt diode barriers.*
2. In any raceway, junction box, or similar fitting, the conductors of the nonincendive circuit cannot be placed with the conductors of any other system, unless (1) the conductors of the two systems are separated by a suitable mechanical partition, or (2) all of the conductors of either system are segregated by a grounded metal shield.
 3. Different nonincendive circuit conductors are recommended to be in separate cables, unless (1) the conductors of each circuit are within a grounded metal shield, or (2) the conductors of each circuit have insulation with a minimum thickness of 0.01 inch {0.254 mm}
 4. If a raceway (including conduit) and cable for nonincendive circuit in Class I, Division 2 or Class II, Division 2 locations are capable of transmitting flammable atmosphere through the raceway and cable from the Division 2 location to a non-hazardous location, they must be properly sealed at the boundary by using of non-approved sealing fittings.

CSA Explosionproof / Dust-ignitionproof Apparatus (in accordance with CEC)**⚠ CAUTION**

- Install the apparatus in any hazardous (classified) locations for which the apparatus has been approved.
- Seal each conduit entering the apparatus enclosure within 450 mm of the enclosure.
- Do not open the apparatus enclosure when an explosive atmosphere is present.

1. Class I, Division 1 locations

1. (a) Threaded rigid metal conduit or (b) cables approved for hazardous locations with associated cable glands approved for the particular hazardous locations, can be used.
2. Threaded joints must have at least five full threads fully engaged.
3. Seals must be provided in conduit or cable systems to prevent passage of gases, vapours or flames.
 - (1) The seal is located in each run of conduit entering the apparatus enclosure as close as practicable to and in no case more than 450 mm from the enclosure.
 - (2) The seal can be made in a sealing fitting approved for the location.
 - Sealing compound must be approved for the purpose.
 - The melting point of the sealing compound is not less than 93°C.
 - The minimum thickness of the sealing compound is not less than the trade size of the conduit and, in no case, less than 5/8 inch {16 mm}.
 - Splices and taps are not made in the fittings.

2. Class I, Division 2 locations

1. (a) Threaded metal conduit, or (b) cables approved for hazardous locations with associated cable glands approved for the particular location, or (c) Type TC cable installed in cable tray, or (d) Type ACWU cable with associated cable glands approved for the particular location, can be used.
2. Seals must be provided in conduit or cable systems to prevent passage of gases, vapours or flames.
 - (1) The seal is located in each run of conduit entering the apparatus enclosure as close as practicable to and in no case more than 450 mm from the enclosure;
 - (2) The sealing in Class I, Division 2 locations conforms to 1.3.(2).

3. Class II, Division 1 locations

1. (a) Threaded rigid metal conduit, or (b) cables approved for hazardous locations with associated cable glands approved for the particular hazardous location, can be used.
2. Where a raceway provides communication between the apparatus enclosure and an enclosure that is not required to be dust-tight, the entrance of dust into the dust-tight enclosure through the raceway must be prevented by (a) a permanent and effective seal, or (b) a horizontal section not less than 3 m long in the raceway, or (c) a vertical section of raceway not less than 1.5 m long and extending downward from the dust-tight enclosure.

4. Class II, Division 2 locations

1. (a) Threaded metal conduit, or (b) cables approved for hazardous locations with associated cable glands approved for the particular location, or (c) Type TC cable installed in cable tray, or (d) Type ACWU cable with associated cable glands approved for the particular location, can be used.
2. Sealing of raceways conforms to 3.2.

5. Class III, Division 1 locations

1. Wiring methods
 - (a) Threaded rigid metal conduit or (b) cables approved for hazardous locations with associated cable glands approved for the particular hazardous locations, can be used.
2. Sealing

Sealing means are not required.

6. Class III, Division 2 locations

1. Wiring methods

The wiring methods in Class III, Division 2 locations conforms to 5.1. except that in sections, compartments, or areas used solely for storage and containing no machinery. (In such sections, compartments, or areas, open wiring methods conforming to the rules for non-hazardous locations may be used.)
2. Sealing

Sealing means are not required.

ISSeP/ATEX Flameproof apparatus (in accordance with CENELEC standards) (English)

Safety information marked on the equipment



II 2 G EEx d IIC T6

ISSeP 02ATEX056

IP66

YAMATAKE Corporation, KANAGAWA-KEN, 253-0113, JAPAN

Ambient temperature: -20°C to +70°C

DO NOT OPEN WHEN AN EXPLOSIVE GAS ATMOSPHERE is PRESENT

General

1. The apparatus protected by the flameproof enclosure in accordance with EN 50018 can be installed in such hazardous areas, for which the apparatus has been certified, as an explosive atmosphere containing flammable substances in the form of gas, vapour, mist or dust may be present.

~Note *The apparatus has been certified to comply with EN 50281-1-1 (dust ignition protection).*

2. The apparatus enclosure must be kept closed in the hazardous areas when the apparatus is energized because the internal circuit of the apparatus is capable of igniting the explosive atmosphere. (Never connect any hand-held communicator to the apparatus terminals by opening the cover, except while no explosive atmosphere is present.)
3. It is required to connect the external earthing terminal of the apparatus to the equipotential bonding system which includes protective conductors, metal conduits, metal cable sheaths, steel wire armouring and metallic parts of structures, but does not include the neutral conductors of the power systems.

~Note *The protective conductor to which exposed conductive parts of equipment (machines, apparatus, devices, components and instrumentation thereof) are connected, must be separated in the hazardous area from the neutral conductor, and must be connected to the power system earth point in the non-hazardous area, if the power system is directory earthed.*

4. For external earthing and bonding of the apparatus it is recommended to use a cable lug so that the conductor is secured against loosening and twisting and that the contact pressure is permanently secured.
5. Either cable systems (cable entry systems) or conduit systems can be employed for wiring of the apparatus in the hazardous areas (see Cable systems or “Conduit systems” on page xvii).
6. Non-sheathed single core cables are not permitted for live conductors unless they are installed inside enclosures or conduit systems.
7. Conduits and, in special cases, cables (for example, where there is a pressure difference) must be sealed so as to prevent the passage of the explosive atmosphere.

~Note *Further information concerning installation and maintenance of the apparatus is given by relevant clauses of the following documents.*

*EN 60079-14 Electrical apparatus for explosive gas atmospheres
Part 14: Electrical installations in hazardous areas*

*EN 60079-17 Part 17: Inspection and maintenance of electrical
installations in hazardous areas.*

*EN 60079-19 Part 19: Repair and overhaul for apparatus used in explosive
atmospheres*

*EN 50281-1-2 Electrical apparatus for use in the presence of combustible
dust*

Part 1-2: Electrical apparatus protected by enclosures

-- Selection, installation and maintenance

Cable systems

1. Thermoplastic sheathed cables, thermosetting sheathed cables, or elastomeric sheathed cables can be selected for fixed wiring in the hazardous areas.
2. Flameproof cable entry devices (cable glands) certified to comply with EN 50018 and appropriate to the type of cable employed, must be used for the connection of cables to the apparatus.

Conduit systems

For conduit systems, relevant national standards or codes of practice are followed prior to the following recommendations.

1. Screwed heavy gauge steel, solid drawn or seam welded conduit, or flexible conduit for protection of cables in explosive atmospheres (see ISO 10807) can be selected for fixed wiring in the hazardous areas.
2. Conduit must be threaded for connection to permit the full engagement of five threads.
3. Either conduit entry devices or sealing devices such as stopping boxes are provided at the wall of the apparatus enclosure to limit the pressure piling effect and to prevent hot gases from entering the conduit system from the enclosure containing a source of ignition. Each type of both the devices must be certified to comply with EN 50018.
4. The stopping boxes, if used, are filled with a compound which does not shrink or setting and is impervious to, and unaffected by, chemicals found in the hazardous area. The depth of the compound in the stopping box is at least equal to the internal diameter of the conduit, but in no case less than 10 mm.
5. When the conduit contains three or more non-sheathed single or multi-core cables, the total cross-sectional areas of cables, including insulation, are not more than 40% of the cross-sectional area of the conduit.

Installation in explosive atmospheres caused by air/dust mixtures

1. Conduit or cable glands, if employed to connect cables to the apparatus, must be selected and used in such a way that an IP6X protection (dust-tight) is guaranteed.
2. It is recommended to maintain the apparatus so that the dust layer will not exceed a thickness of 5 mm.

~Note *Where the ignition temperature of a dust layer up to 5 mm thickness is equal to, or higher than, the value that is obtained by adding 75K to the maximum surface temperature of the enclosure "T135°C" as marked on the apparatus, the apparatus is incapable of causing ignition of the dust layer. (T135°C is based on the maximum ambient temperature.)*

ISSeP/ATEX Équipement ignifuge

(en conformité avec les standards de CENELEC)

(French)

Information concernant le marquage



ISSeP 02ATEX056

IP66

YAMATAKE Corporation, Préfecture de KANAGAWA, 253-0113, JAPON

Température ambiante: entre -20°C et +70°C

DO NOT OPEN WHEN AN EXPLOSIVE GAS ATMOSPHERE is PRESENT

Généralités

1. L'équipement protégé par le coffret ignifuge en conformité avec l'EN 50018 peut être installé dans de telles zones dangereuses, pour lesquelles l'équipement a été certifié, du fait que nous pouvons être en présence d'un environnement explosif contenant des substances inflammables sous forme de gaz, de vapeur, de brouillard ou de poussière.

~Remarque *L'équipement est certifié conforme à l'EN 50281-1-1 (poussière combustible).*
2. Le coffret de l'équipement doit être tenu fermé dans des zones dangereuses lorsque l'équipement est sous tension, car le circuit interne de l'équipement risque d'enflammer l'environnement explosif. (Ne jamais raccorder un communicateur portatif aux sorties de l'équipement en ouvrant le couvercle, sauf en l'absence d'un environnement explosif).
3. Il est impératif de raccorder la borne de terre externe de l'équipement au système de liaison équipotentielle qui comprend les conducteurs de protection, les gaines métalliques, les enveloppes métalliques pour câble, l'armure en fils d'acier et des parties métalliques des structures, mais qui ne comprend pas les conducteurs neutres des réseaux électriques.

~Remarque *Le conducteur de protection auquel sont connectées des parties conductrices apparentes de l'équipement (machines, équipement, dispositifs, composants et d'autres instruments s'y rapportant) doit être séparé dans des zones dangereuses du conducteur neutre, et doit être raccordé au point de mise à la terre du réseau électrique dans des zones non dangereuses, si le réseau électrique est directement lié à la terre.*
4. Pour la mise à la terre et la métallisation externes de l'équipement, il est recommandé d'utiliser le serre-câble afin que le conducteur soit sécurisé de manière à éviter le desserrage et la torsion et que la pression de contact se trouve en permanence assujettie.
5. Des systèmes de câble (systèmes de sortie de câble) ou des systèmes de gaines peuvent être utilisés pour le câblage de l'équipement dans des zones dangereuses (voir Systèmes de câble ou "Systèmes de gaines" à la page xix.).
6. Les câbles unipolaires non blindés ne sont pas autorisés pour les conducteurs chargés, à moins qu'ils soient installés à l'intérieur des coffrets ou des systèmes de gaines.
7. Les gaines et, dans les cas spéciaux, les câbles (par exemple, lorsqu'il y a une différence de tension) doivent être bloqués pour empêcher le passage de l'environnement à risque d'explosion.

~Remarque *L'information supplémentaire concernant l'installation et l'entretien de l'équipement est disponible dans les clauses applicables des documents suivants.*

EN 60079-14 Équipement électrique pour des environnements pressurisés présentant des risques d'explosion

Chapitre 14: Installations électriques dans des zones dangereuses

EN 60079-17 Chapitre 17: Inspection et entretien des installations électriques dans des zones dangereuses

EN 60079-19 Chapitre 19: Réparation et révision de l'équipement utilisé dans des environnements présentant des risques d'explosion

EN 50281-1-2 Équipement électrique à utiliser en présence de poussière combustible

*Chapitres 1-2: Équipement électrique protégé par des coffrets
-- Sélection, installation et entretien*

Systèmes de câbles

1. Des câbles protégés par une gaine thermoplastique, des câbles protégés par une gaine thermodurcissable ou des câbles protégés par une gaine élastomérique peuvent être sélectionnés pour le câblage fixe dans des zones dangereuses.
2. Le dispositif d'entrée du câble ignifuge (goupilles de câbles) certifié conforme à l'EN 50018 et approprié au type de câble utilisé doit être utilisé pour le raccordement des câbles avec l'équipement.

Systèmes de gaines

Pour les systèmes de gaines, avant de suivre les recommandations suivantes, il faut suivre les standards nationaux applicables ou les codes de procédure d'application.

1. Un acier fort vissé, une gaine étirée sans soudure ou par soudure à recouvrement ou une gaine flexible de protection de câbles dans des environnements présentant des risques d'explosion (voir ISO 10807) peuvent être sélectionnés pour le câblage fixe dans des zones dangereuses.
2. La gaine doit être raccordée par raccord fileté pour permettre l'engagement complet des cinq filetages.
3. Soit les dispositifs d'entrée soit les matériels de cachetage tels que les coffrets de stabilisation sont prévus sur la paroi du coffret de l'équipement pour limiter l'effet d'accumulation de tension et pour éviter que des gaz chauds ne pénètrent dans le système de gaines du coffret contenant la source ignifuge. Les deux types de dispositifs doivent être certifiés conformes à l'EN 50018.
4. Les coffrets de stabilisation, s'ils sont utilisés, sont remplis d'un composé qui ne diminue pas ou d'une installation et sont étanches aux produits chimiques existants dans la zone dangereuse et ne subissent pas leur influence. L'épaisseur du composé dans le coffret de stabilisation est au moins équivalente au diamètre interne de la gaine, mais ne doit jamais être inférieur à 10 mm.
5. Lorsque la gaine contient trois câbles unipolaires ou multipolaires non-gainés ou plus, la totalité de la superficie de la section transversale des câbles, y compris l'isolation, ne doit pas dépasser 40 % de la superficie de la section transversale de la gaine.

Installation dans des environnements présentant des risques d'explosion provoquée des mélanges air / poussière

1. Les gaines ou les goupilles de câbles, si elles sont utilisées pour raccorder les câbles à l'équipement, doivent être sélectionnées et utilisées de telle manière que la protection de IP6X (étanche aux poussières) soit garantie.
2. Il est recommandé d'entretenir l'équipement de telle façon que la couche de poussière ne soit pas supérieure à 5 mm d'épaisseur.

~Remarque Lorsque la température d'inflammation d'une couche de poussière dépassant 5 mm est égale ou supérieure à la valeur obtenue par l'addition de 75K à la température maximale de surface du coffret "T135°C" comme indiqué sur la l'équipement, l'équipement ne risque pas de provoquer l'inflammation de la couche de poussière (T135°C est basée sur la température ambiante maximale).

ISSeP/ATEX-zertifiziertes druckfestes Betriebsmittel

(German)

(bescheinigt nach CENELEC-Standards)

Kennzeichnung sinformation

II 2 G EEx d IIC T6

ISSeP 02ATEX056

IP66

Umgebungstemperatur: -20...+70°C

YAMATAKE Corporation, KANAGAWA-KEN, 253-0113, JAPAN

DO NOT OPEN WHEN AN EXPLOSIVE GAS ATMOSPHERE is PRESENT

Allgemeines

1. Das durch ein druckfestes Gehäuse nach EN 50018 geschützte Betriebsmittel kann in Gefahrenbereichen installiert werden, für die das Betriebsmittel zertifiziert wurde und in denen eine explosionsfähige Atmosphäre mit brennbaren Gasen, Dämpfen oder Nebeln vorhanden ist.
- ~Hinweis** *Dem Betriebsmittel wurde die Einhaltung der Norm EN 50281-1-1 (Elektrische Betriebsmittel zur Verwendung in Bereichen mit brennbarem Staub) bescheinigt.*
2. Das Gehäuse des Betriebsmittels muss in Gefahrenbereichen geschlossen gehalten werden, wenn das Betriebsmittel unter Spannung gesetzt wird, da die internen Schaltungen des Betriebsmittels eine explosionsfähige Atmosphäre entzünden können. (Verbinden Sie in explosionsfähiger Atmosphäre nach Öffnen des Deckels niemals einen tragbaren SFC-Communicator mit den Anschlüssen des Betriebsmittels.)
 3. Der externe Erdanschluss des Betriebsmittels muss mit dem Potenzialausgleichssystem verbunden werden, welches Schutzleiter, Leitungsführungen und Kabelschirme aus Metall, Armierungen aus Stahldraht und Aufbaukomponenten aus Metall enthält, nicht aber Nullleiter für die Stromanlagen.
- ~Hinweis** *Der Schutzleiter, mit dem offene leitfähige Teile der Einrichtung (Maschinen, Betriebsmittel, Geräte sowie deren Komponenten und Instrumente) verbunden sind, muss im Gefahrenbereich vom Nullleiter getrennt und an einen Erdungspunkt der Stromanlage im Nichtgefahrenbereich angeschlossen sein, wenn die Stromanlage direkt geerdet wird.*
4. Bei externer Erdung des Betriebsmittels wird die Verwendung eines Kabelschuhs empfohlen, damit der Leiter gegen Ablösen und Verdrehen gesichert und der Kontaktdruck konstant vorhanden ist.
 5. Zur Verkabelung des Betriebsmittels in Gefahrenbereichen lassen sich wahlweise Kabelsysteme (Kabeleinführungssysteme) oder Panzerrohrsysteme verwenden (vgl. Abschnitte "Kabelsysteme" bzw. "Panzerrohrsysteme" auf Seite xxi).
 6. Nicht geschirmte Einleiterkabel sind als spannungsführende Leiter unzulässig, sofern sie nicht in Gehäusen oder Panzerrohrsystemen installiert sind.
 7. Panzerrohre und in bestimmten Fällen auch Kabel (z. B. bei vorhandenem Druckunterschied) müssen versiegelt werden, um die Kabelführung durch explosionsgefährdete Bereiche abzusichern.
- ~Hinweis** *Weitere Informationen zur Installation und Wartung des Betriebsmittels finden Sie in den entsprechenden Abschnitten der folgenden Dokumente:
EN 60079-14 Elektrische Betriebsmittel für gasexplosionsgefährdete Bereiche
Teil 14: Elektrische Anlagen für gefährdete Bereiche*

- EN 60079-17 Elektrische Betriebsmittel für gasexplosionsgefährdete Bereiche Teil 17: Prüfung und Instandhaltung elektrischer Anlagen in explosionsgefährdeten Bereichen*
- EN 60079-19 Elektrische Betriebsmittel für gasexplosionsgefährdete Bereiche Teil 19: Reparatur und Überholung von Betriebsmitteln für den Einsatz in explosionsgefährdeten Bereichen*
- EN 50281-1-2 Elektrische Betriebsmittel zur Verwendung in Bereichen mit brennbarem Staub Teil 1-2: Elektrische Betriebsmittel mit Schutz durch Gehäuse - Auswahl, Errichten und Instandhaltung*

Kabelsysteme

1. Zur Verkabelung in Gefahrbereichen können Kabel mit thermoplastischem, heißhärtendem oder elastomerem Mantel verwendet werden.
2. Für den Anschluss der Kabel an das Betriebsmittel müssen druckfeste Kabeleintrittseinrichtungen (Kabelverschraubungen) verwendet werden, die EN50018-zertifiziert und für den verwendeten Kabeltyp geeignet sind.

Panzerrohrsysteme

In Bezug auf Panzerrohrsysteme haben die jeweilig anwendbaren nationalen Normen oder Verfahrensregeln Vorrang vor den folgenden Empfehlungen.

1. Zur befestigten Verkabelung in Gefahrenbereichen können wahlweise verschraubte Panzerrohre aus schwerem gewalztem oder nahtverschweißtem Stahl oder flexible Panzerrohre zum Schutz von Kabeln in explosionsfähiger Atmosphäre verwendet werden (vgl. IOS 10807).
2. Das Panzerrohr muss so mit Gewindegängen versehen sein, dass es die vollständige Anwendung von mindestens fünf Gewinden ermöglicht.
3. An der Außenseite des Betriebsmittelgehäuses sind entweder Panzerrohrenintrittseinrichtungen oder Dichtungseinrichtungen (z. B. Stopping-Boxen) vorhanden, um den Druckaufbaueffekt zu beschränken und zu verhindern, dass heiße Gase aus dem Gehäuse, welches eine Zündquelle enthält, in das Panzerrohrsystem entweichen können. Der jeweilige Typ der verwendeten Einrichtungen muss EN 50018-zertifiziert sein.
4. Sofern Stopping-Boxen verwendet werden, sind mit einem Material gefüllt, das nicht schrumpft oder abbindet und von Chemikalien, die im Gefahrenbereich auftreten, nicht durchdrungen oder angegriffen werden kann. Die Tiefe des Materials in der Stopping-Box muss zumindest dem internen Durchmesser des Panzerrohrs entsprechen, darf aber nicht weniger als 10 mm betragen.
5. Wenn das Panzerrohr drei oder mehr nicht mit einem Schutzmantel versehene ein- oder mehradrige Kabel enthält, darf die Summe der Querschnitte der Kabel einschließlich der Isolierung nicht größer sein als 40% des Querschnittsbereichs des Panzerrohrs.

Installation in durch Luft-Staub-Gemische explosionsgefährdeten Atmosphären

1. Wenn zum Anschluss von Kabeln an das Gerät Panzerrohr oder Kabelschuhe verwendet werden, müssen diese so ausgewählt und verwendet werden, dass ein IP6X-kompatibler Schutz (Staubdichtigkeitstest) gewährleistet ist.
2. Eine regelmäßige Wartung des Betriebsmittels wird empfohlen, damit die Staubschicht eine Dicke von 5 mm nicht überschreitet.

~Hinweis *Wenn die Entzündungstemperatur einer Staubschicht mit einer maximalen Dicke von 5 mm mindestens gleich der Summe aus $75K$ und der maximalen Oberflächentemperatur des Gehäuses ist (" $T_{135}^{\circ}C$ " entsprechend Kennzeichnung auf dem Betriebsmittel), dann ist eine Entzündung der Staubschicht durch das Betriebsmittel nicht möglich (T_{135}° basiert auf der maximalen Umgebungstemperatur).*

Aparato a prueba de llamas ISSeP/ATEX (de acuerdo con los estándares CENELEC)

(Spanish)

Información de Marca



II 2 G EEx d IIC T6

ISSeP 02ATEX056

IP66

Temperatura ambiente: -20°C a +70°C

YAMATAKE Corporation, KANAGAWA-KEN, 253-0113, JAPÓN

DO NOT OPEN WHEN AN EXPLOSIVE GAS ATMOSPHERE is PRESENT

General

1. El aparato protegido por el recinto a prueba de llamas de acuerdo con EN 50018 se puede instalar en tales áreas peligrosas, para lo que el aparato ha sido certificado, como una atmósfera explosiva que contenga sustancias inflamables en forma de gas, vapor o polvo pueden estar presentes.

~Nota *El aparato se ha certificado para cumplir con EN 50281-1-1 (protección contra la ignición de polvo).*

2. El recinto del aparato se tiene que mantener cerrado en las áreas peligrosas cuando el aparato tenga alimentación porque el circuito interno del aparato es capaz de encender la atmósfera explosiva. (No conecte nunca ningún comunicador de mano a los terminales del aparato abriendo la tapa, excepto cuando no haya presente ningún explosivo en la atmósfera).
3. Se requiere conectar el terminal de toma externo de toma de tierra del aparato al sistema de unión equipotencial, que incluye conductores de protectores, conductos de metal, fundas de metal para cables, armazones de acero para cables y piezas metálicas de estructuras, pero no incluye los conductores neutros de los sistemas de alimentación.

~Nota *El conductor protector al que se conectan piezas de equipo conductoras expuestas (máquinas, aparato, dispositivos, componentes y sus instrumentaciones) tiene que estar separado en el área de peligro del conductor neutro y tiene que estar conectado al punto de toma de tierra del sistema de alimentación en el área sin peligros, si el sistema de alimentación está conectado a tierra por directorio.*

4. Para la unión y toma de tierra externa del aparato se recomienda utilizar un lastre de cable para que el conductor esté asegurado contra el aflojamiento y el rizado y que la presión de contacto está asegurada permanentemente.
5. Los sistemas de (sistemas de entrada de cables) o los sistemas de conductos se pueden emplear para cablear el aparato en las áreas peligrosas (ver Sistemas de cable o "Sistemas de conductos" en la página xxiii).
6. No se permiten los cables de un solo conductor sin funda para los conductores en vivo a menos que se instalen dentro de los recintos o sistemas de conductos.
7. Los conductos y, en casos especiales, los cables (por ejemplo, en donde exista diferencia de presión) tienen que estar sellados para prevenir el paso de la atmósfera explosiva.

~Nota *Se ofrece mayor información acerca de la instalación y del mantenimiento del aparato en las cláusulas relevantes de los siguientes documentos.*

- EN 60079-14 Aparatos eléctricos para atmósferas de gas explosivo
Parte 14: Instalaciones eléctricas en áreas peligrosas*
- EN 60079-17 Parte 17: Inspección y mantenimiento de instalaciones
eléctricas en áreas peligrosas.*
- EN 60079-19 Parte 19: Reparación y puesta a punto de aparatos
utilizados en atmósferas explosivas*
- EN 50281-1-2 Aparatos eléctricos para uso en presencia de polvo de
combustible
Parte 1-2: Aparatos eléctricos protegidos por recintos
-- Selección, desinstalación y mantenimiento*

Sistemas de cable

1. Cables con funda termoplástica, cables con funda termosolidificable o cables con funda elastomérica se pueden seleccionar para el cableado fijo en las áreas de peligro.
2. Dispositivos de entrada de cables a prueba de llamas (pasatapas de cable) que estén certificados como que cumplen con EN 50018 y sean adecuados para el tipo de cable utilizado, se tienen que utilizar para la conexión de los cables a los aparatos.

Sistemas de conductos

Para los sistemas de conductos, se siguen los estándares nacionales o los códigos de práctica antes de las siguientes recomendaciones.

1. Se puede seleccionar para el cableado fijo en las áreas peligrosas acero de calibre pesado atornillado, conducto de juntas soldadas o sólido o conducto flexible para la protección de cables en atmósferas explosivas (ver ISO 10807).
2. Los conductos tienen que ser trenzados para que la conexión permita conectar de manera completa cinco hilos.
3. Los dispositivos de entrada al conducto o los dispositivos para sellado se suministran en la pared del recinto del aparato para limitar el efecto de apilado de presión y para prevenir que entren gases calientes en el sistema del conducto desde el recinto que contiene una fuente de encendido. Cada tipo de ambos dispositivos tiene que estar certificado como que cumple con EN 50018.
4. Las cajas de obturación, si es que se utilizan, están llenos de un compuesto que no encoge ni se solidifica y es impermeable a, e inafectado por, las sustancias químicas que se encuentren en el área peligrosa. La profundidad del compuesto de la caja de obturación es al menos igual al diámetro interno del conducto, pero en ningún caso menor de 10 mm.
5. Cuando el conducto contiene tres o más cables sin funda de un solo hilo o de varios hilos, las áreas de secciones cruzadas totales de los cables, incluyendo el aislante, no son de más del 40% del área de sección cruzada del conducto.

Instalación en atmósferas explosivas causadas por mezclas de aire y polvo

1. Si se utiliza un conducto de pasatapas de cables para conectar cables al aparato tiene que ser seleccionado y utilizado de modo que se garantice protección IP6X (estricta al polvo).
2. Se recomienda mantener el aparato para que la capa de polvo no supere un grosor de 5 mm.

~Nota *En donde la temperatura de ignición de una capa de polvo de hasta 5 mm de grosor sea igual a, o mayor de, al valor que se obtiene añadiendo 75K a la temperatura de superficie máxima del recinto "T135° C" según está marcado en el aparato, el aparato no puede causar la ignición de la capa de polvo. (T135° C está basado en la temperatura ambiente máxima).*

Apparecchio antideflagrante a norme ISSeP/ATEX

(Italian)

(in conformità alle norme CENELEC)

Informazioni riguardant: il marchio

II 2 G EEx d IIC T6

ISSeP 02ATEX056

IP66

Temperatura ambiente: da -20°C a +70°C

YAMATAKE Corporation, KANAGAWA-KEN, 253-0113, JAPAN

DO NOT OPEN WHEN AN EXPLOSIVE GAS ATMOSPHERE is PRESENT

Generalità

1. L'apparecchio protetto da involucro antideflagrante realizzato a norme EN 50018 può essere installato nelle aree pericolose per le quali l'apparecchio stesso è stato certificato, quali ad esempio con atmosfera esplosiva contenente sostanze infiammabili presenti sotto forma di gas, vapore, nebbia o polveri.
~Nota *L'apparecchio è stato certificato essere in ottemperanza alle norme EN 50281-1-1 (protezione dall'accensione di polveri).*
2. Quando l'apparecchio è sotto tensione, nelle aree pericolose il proprio involucro deve essere mantenuto chiuso poiché la circuiteria interna è in grado di innescare l'atmosfera esplosiva. (Non collegare mai alcun tipo di dispositivo di comunicazione portatile ai terminali dell'apparecchio aprendone il coperchio, ad eccezione nei casi in cui vi sia assenza di atmosfera esplosiva.)
3. È necessario collegare il terminale di terra esterno dell'apparecchio al sistema di collegamento equipotenziale provvisto di conduttori protettivi, condotte metalliche, rivestimenti metallici dei cavi, armature con cavi di acciaio e parti metalliche di strutture, ma che sia al contempo sprovvisto dei conduttori neutrali dell'impianto di alimentazione.
~Nota *Il conduttore protettivo al quale sono collegate le parti conduttive esposte di attrezzature (macchine, apparecchi, dispositivi, componenti e strumenti), nelle aree pericolose deve essere mantenuto separato dal conduttore neutrale, mentre nelle aree non pericolose deve essere collegato al punto di terra dell'impianto di alimentazione qualora questo ultimo sia provvisto di messa a terra diretta.*
4. Per quanto riguarda il collegamento a terra esterno ed il collegamento equipotenziale dell'apparecchio, si raccomanda di applicare un capocorda al cavo in modo che il conduttore rimanga saldamente collegato senza allentarsi o torcersi e che la pressione di contatto sia permanentemente assicurata.
5. Per il cablaggio dell'apparecchio nelle aree pericolose è possibile utilizzare sia sistemi a cavo (sistemi di ingresso cavi) sia condotte elettriche (al riguardo si prega di vedere la sezione "Sistemi a cavo" o "Sistemi a condotte elettriche" a pagina xxv).
6. Come conduttori sotto tensione non devono essere utilizzati cavi a filo conduttore interno singolo isolato non schermati, ad eccezione dei casi in cui essi siano installati all'interno di involucri o di condotte elettriche.
7. Le condotte elettriche e, in casi speciali, i cavi (ove ad esempio sussistano differenze di pressione), devono essere sigillati in modo da prevenire il passaggio di atmosfera esplosiva.

~Nota *Ulteriori informazioni riguardanti l'installazione e la manutenzione dell'apparecchio sono riportate nelle corrispondenti parti della seguente documentazione:*

*EN 60079-14 Apparecchi elettrici per atmosfere esplosive Parte 14:
Installazioni elettriche in aree pericolose*

EN 60079-17 Parte 17: Ispezione e manutenzione delle installazioni elettriche in aree pericolose

EN 60079-19 Parte 19: Riparazione e revisione degli apparecchi utilizzati in atmosfera esplosiva

*EN 50281-1-2 Apparecchi elettrici utilizzati in presenza di polveri combustibili
Parte 1-2: Apparecchi elettrici protetti da involucri*

-- Scelta, installazione e manutenzione

Sistemi a cavo

1. Per i cablaggi fissi nelle aree pericolose è possibile selezionare tra cavi schermati termoplastici, cavi schermati termoindurenti o cavi schermati elastomerici.
2. Per il collegamento dei cavi all'apparecchio è necessario impiegare dispositivi antideflagranti di ingresso cavi (tenute) certificati secondo le norme EN 50018 e idonei al tipo di cavo utilizzato.

Sistemi a condotte elettriche

Per i sistemi a condotte elettriche, prima di osservare le raccomandazioni di seguito riportate si raccomanda di osservare le relative norme o pratiche in uso localmente.

1. Per i cablaggi fissi nelle aree pericolose è possibile scegliere, per la protezione dei cavi in atmosfera esplosiva, tra condotte in lamina spessa di acciaio, condotte trafilate o a saldature continue oppure ancora condotte flessibili (si prega di vedere al riguardo le norme ISO 10807).
2. Per eseguirne il collegamento, le condotte devono essere filettate in modo da realizzare pieno contatto su cinque filetti.
3. Al fine di limitare l'effetto di accumulo di pressione e prevenire l'ingresso dei gas caldi nel sistema di condotte dall'involucro contenente una sorgente di innesco, sulla parete dell'apparecchio sono predisposti dispositivi di ingresso per le condotte oppure dispositivi sigillanti quali scatole di arresto. Ciascun tipo per entrambi i dispositivi deve essere certificato secondo le norme EN 50018.
4. Le scatole di arresto, qualora impiegate, sono riempite di una miscela che non si ritira né solidifica e che è inoltre impervia e non affetta dalle sostanze chimiche presenti nelle aree pericolose. La profondità della miscela nella scatola di arresto è almeno uguale al diametro interno della condotta, ma in nessun caso è inferiore a 10 mm.
5. Qualora la condotta contenga tre o più cavi a conduttore singolo o multiplo non rivestiti, la sezione totale dei cavi stessi, compreso l'isolamento, non supera il 40% della sezione della condotta.

Installazione in atmosfera esplosiva determinata dalla presenza di miscele di aria/polveri

1. Qualora impiegate per collegare i cavi all'apparecchio, le tenute delle condotte o dei cavi devono essere selezionate ed utilizzate in modo tale da garantire una protezione in classe IP6X (a tenuta di polveri).
2. Si raccomanda di mantenere l'apparecchio in modo tale che lo strato delle polveri non superi 5 mm di spessore.

~Nota *Qualora la temperatura di accensione di uno strato di polveri spesso sino a 5 mm sia uguale o superiore al valore ottenuto aggiungendo 75K alla temperatura superficiale massima dell'involucro "T135°C", come risulta dalla marcatura eseguita sull'apparecchio, quest'ultimo non sarebbe in grado di determinare l'accensione dello strato stesso. (Il valore T135°C si basa sulla massima temperatura ambientale.)*

ISSeP/ATEX Vlambestendig apparaat

(Dutch)

(in overeenstemming met de CENELEC normen)

Maketing informatie

II 2 G EEx d IIC T6

ISSeP 02ATEX056

IP66

Omgevingstemperatuur: -20°C tot +70°C

YAMATAKE Corporation, KANAGAWA-KEN, 253-0113 JAPAN

DO NOT OPEN WHEN AN EXPLOSIVE GAS ATMOSPHERE is PRESENT

Algemeen

1. Gezien er een explosieve atmosfeer kan zijn die ontvlambare substanties bevat in de vorm van gas, mist of stof, mag het apparaat, beschermd door de vlambestendige behuizing in overeenstemming met EN 50018, geïnstalleerd worden in die gevaarlijke zones voor welke het gecertificeerd is.
~opgelet *Het apparaat is gecertificeerd te voldoen aan EN 50281-1-1 (stofontvlammingsbeveiliging)*
2. Gezien de interne schakelingen van het apparaat de explosieve atmosfeer zou kunnen doen ontvlammen, moet de behuizing van het apparaat steeds gesloten blijven wanneer het apparaat onder spanning staat. (Open nooit de behuizing om een draagbare communicator aan te sluiten aan de terminalen van het apparaat wanneer er een explosieve atmosfeer aanwezig is.)
3. Het is verplicht om de externe aarding van het apparaat te verbinden met het equipotentiale verbinding systeem dat niet de neutrale lijnen van het elektriciteitssysteem bevat, maar wel de beschermende geleiders, de metalen pijpsystemen, de metalen kabelscheiden, de staaldraadbewapening en de metalen onderdelen van de structuur.
~opgelet *Indien het elektriciteitssysteem direct geaard is, moet de beschermende geleider (waaraan de blootgestelde geleidende onderdelen van de apparatuur verbonden zijn, zoals machines, apparaten, toestellen, componenten en hun instrumentatie) in de gevaarlijke ruimte apart gehouden worden van de neutrale geleider. De beschermende geleider moet verbonden worden het aardingspunt van het elektriciteitssysteem buiten de gevaarlijke ruimte.*
4. Het is aangeraden om een kabelspanner te gebruiken voor de externe aarding van het apparaat zodat de geleider beschermd is tegen loskomen en verdraaien en zodat een constante contactdruk verzekerd is.
5. Om het apparaat aan te sluiten in de gevaarlijke zone kan ofwel een kabelsysteem (kabel ingangssystemen) of een pijpsysteem toegepast worden. (zie Kabelsystemen of "Pijpsystemen" op pagina xxvii)
6. Kabels met enkelvoudige kern en zonder schede zijn niet toegestaan voor geleiders onder spanning tenzij ze geïnstalleerd worden in een behuizing of een pijpsysteem.
7. Pijpen en, in speciale gevallen, kabels (bijvoorbeeld wanneer er een drukverschil is) moeten hermetisch afgesloten worden om te voorkomen dat de explosieve atmosfeer ontsnapt.
~opgelet *Verdere informatie aangaande de installatie en het onderhoud van het apparaat is te vinden in de relevante secties van volgende documenten:
EN 60079-14 Elektrische apparaten voor explosieve gasatmosferen*

Deel 14: Elektrische installaties in gevaarlijke omgevingen

EN 60079-17 Deel 17: Inspectie en onderhoud van elektrische installaties in gevaarlijke omgevingen

EN 60079-19 Deel 19: Herstelling en vernieuwing van apparaten, gebruikt in een explosieve atmosfeer

EN 50281-1-2 Elektrische apparaten voor gebruik in de aanwezigheid van ontvlambaar stof

Deel 1-2: Elektrische apparaten beschermd door behuizingen

Keuze, installatie en onderhoud

Kabelsystemen

1. Voor de vaste bedrading in de gevaarlijke zones kunnen kabels gebruikt worden met een thermoplastische schede, met een thermisch gezette schede of met een elastomeren schede.
2. Voor de verbinding van de kabels met het apparaat moeten vlamveilige kabeltoegangcomponenten (kabelpakkingsbussen) gebruikt worden, zoals gespecificeerd in EN 50018, die geschikt zijn voor het type kabel dat gebruikt wordt.

Pijpsystemen

Vooraleer met volgende aanbevelingen rekening te houden, dienen de relevante nationale standaarden of gebruiksbepalingen gevolgd te worden.

1. Voor de vaste bedrading in de gevaarlijke zone kan er gekozen worden voor dik gevezen staal, voor getrokken of gelaste pijp of voor flexibele pijp, bestemd voor de beveiliging van leidingen in een explosieve atmosfeer (zie ISO 10807)
2. De pijp moet bedraad worden voor een verbinding die het volledige gebruik van 5 draden toelaat.
3. Om drukeffecten te beperken en om te verhinderen dat hete gassen in de pijp doordringen vanuit de behuizing die een ontvlammingsbron bevat, moeten pijptoegangscomponenten of verzegelingscomponenten zoals stopdozen gebruikt worden aan het oppervlak van de behuizing van het apparaat. Elk type van beide soorten componenten moet gecertificeerd voldoen aan EN 50018.
4. Indien stopdozen gebruikt worden, moeten deze gevuld zijn met een materiaal dat niet krimpt of zet, dat ondoordringbaar is voor en niet aangetast wordt door de chemicaliën aanwezig in de gevaarlijke zone. De dikte van het materiaal in de stopdoos is op zijn minst gelijk aan de interne diameter van de pijp en in geen geval minder dan 10mm.
5. Indien de pijp drie of meer enkelvoudige kabels zonder schede of kabels met meervoudige kern bevat, dan mag de totale doorsnede oppervlakte van de kabels (inclusief de isolatie) niet meer dan 40% bedragen van de doorsnede oppervlakte van de pijp.

Installatie in een explosieve atmosfeer veroorzaakt door lucht/stof mengsels

1. Indien pijp- of kabelpakkingsbussen gebruikt worden om kabels met het apparaat te verbinden, moeten deze gekozen en gebruikt worden zodanig dat een IP6X beveiliging (stofdicht) verzekerd is.
2. Het is aangeraden het apparaat zo te onderhouden dat de stoflaag niet dikker wordt dan 5 mm.

~opgelet *Wanneer de ontvlammings temperatuur van een stof laag van maximum 5mm gelijk of hoger is dan de waarde bekomen door 75K bij te tellen bij de maximale oppervlaktetemperatuur van de behuizing "T135°C" als aangegeven op het apparaat, dan kan het apparaat geen ontvlaming van de stoflaag veroorzaken. (T135°C is gebaseerd op de maximale omgevingstemperatuur.)*

Aparelho a Prova de Chamas ISSeP/ATEX

(Portuguese)

(Conforme o padrão CENELEC)

Information d'inscription

II 2 G EEx d IIC T6

ISSeP 02ATEX056

IP66

Temperatura ambiente: -20°C a +70°C

YAMATAKE Corporation, KANAGAWA-KEN, 253-0113, JAPÃO

Aspectos Gerais

1. O aparelho protegido com vedação à prova de chamas de acordo com EN 50018 pode ser instalado em áreas perigosas, para as quais o aparelho é certificado, como, por exemplo, locais com atmosfera explosiva contendo substâncias inflamáveis na forma de gás, vapor, umidade ou sujeira.

~Nota *O aparelho foi certificado de acordo com EN 50281-1-1 (proteção contra ignição do pó)*

2. O aparelho deve ser mantido vedado em áreas perigosas quando ele é energizado, pois o circuito interno do aparelho pode inflamar a atmosfera explosiva. (Não conecte, de forma alguma, um comunicador segurado com as mãos nos terminais do aparelho ao abrir a tampa, a menos que não haja atmosfera explosiva.)
3. É necessário conectar o terminal-terra externo do aparelho ao sistema de ligação equipotencial em que se incluem os condutores de proteção, conduítes de metal, bainhas de cabo de metal, blindagem de arame de aço e partes metálicas de estruturas, mas que não se incluem os condutores neutros dos sistemas de energia.

~Nota *Na área perigosa, o condutor de proteção, ao qual são conectadas as partes condutoras expostas do equipamento (máquinas, aparelho, dispositivos, componentes e seus instrumentos), deve ser separado do condutor neutro, e, na área não-perigosa, deve ser conectada ao ponto-terra do sistema de energia, caso o sistema de energia estiver ligado à terra de forma direcionada.*

4. Para ligação externa à terra e conexão do equipamento, recomenda-se usar um terminal para cabo de modo que o condutor seja ajustado contra afrouxamento e torção, e que a pressão de contato seja garantida de forma permanente.
5. Tanto os sistemas de cabo (sistemas de entrada de cabo) como os sistemas de conduíte podem ser empregados para a fiação do aparelho em áreas perigosas (Veja “Sistemas de cabo” ou “Sistemas de conduíte”, à página xxix).
6. Não é permitido utilizar os cabos de núcleo simples não-blindados em condutores vivos, a menos que eles estejam instalados dentro de sistemas vedados ou de conduítes.
7. Os conduítes e, em casos especiais, os cabos (por exemplo, onde existe diferença de pressão) devem ser vedados para evitar a passagem de atmosfera explosiva.

~Nota *Informações adicionais a respeito de instalação e manutenção do aparelho são dadas nas cláusulas relacionadas aos seguintes documentos:*

EN 60079-14 Aparelho elétrico para atmosfera com gás explosivo

- Parte 14: Instalações elétricas em áreas perigosas*
- EN 60079-17 Parte 17: Inspeção e manutenção de instalações elétricas em áreas perigosas*
- EN 60079-19 Parte 19: Conserto e desmontagem para manutenção de aparelho usado em atmosferas explosiva*
- EN 50281-1-2 Aparelho elétrico para usar em presença de sujeira combustível*
- Parte 1-2: Aparelhos elétricos protegidos por vedações - Seleção, instalação e manutenção*

Sistemas de cabo

1. Para fiação fixa em áreas perigosas, podem ser selecionados cabos blindados termoplásticos, cabos blindados termofixos, ou cabos blindados elastoméricos.
2. Os dispositivos de entrada de cabo à prova de chamas (junções do cabo), certificados de acordo com EN 50018 e apropriados ao tipo de cabo empregado, devem ser usados para a conexão de cabos ao aparelho.

Sistemas de conduíte

Para sistemas de conduíte, seguem-se os padrões nacionais relacionados ou os códigos de prática, antes das seguintes recomendações.

1. Para a fiação fixa em áreas perigosas, podem ser selecionados conduíte de aço de gabarito pesado roscado, conduíte trefilado sólido ou soldado com costura, ou conduíte flexível para a proteção dos cabos em atmosferas explosivas (veja ISO 10807).
2. O conduíte deve ser roscado para conexão, de forma a permitir o encaixe completo das cinco roscas.
3. Tanto os dispositivos de entrada do conduíte como os dispositivos de selagem, tais como as caixas de parada, estão colocados na parede da vedação do aparelho para limitar o efeito de acúmulo de pressão e para evitar a entrada de gases quentes no sistema de conduíte da vedação que contém uma fonte de ignição. Cada um dos dois dispositivos deve ser certificado se está conforme o EN 50018.
4. As caixas de parada, se usadas, são enchidas com um composto que não encolha nem se fixe, e que seja impermeável em relação aos produtos químicos encontrados na área perigosa e que não seja, também, afetados pelos mesmos. A profundidade do composto na caixa de parada deverá ser de no mínimo igual ao diâmetro interno do conduíte, mas nunca, menor que 10 mm.
5. Quando o conduíte contém três ou mais cabos não-blindados de núcleo simples ou múltiplo, o total das áreas das seções transversais dos cabos, incluindo o isolamento, é de, no máximo, 40% da área da seção transversal do conduíte.

Instalação em atmosferas explosivas causadas por mistura de ar/sujeira

1. O conduíte ou juntas de cabos, quando usados para conectar cabos ao aparelho, devem ser selecionados e usados de forma que se garanta a proteção IP6X (à prova de sujeira).
2. Recomenda-se manter o aparelho de forma que a camada de sujeira não exceda a espessura de 5 mm.

~Nota *Quando a temperatura de ignição da camada de sujeira com espessura de até 5 mm é igual ou maior que o valor obtido pela adição de 75K à temperatura máxima da superfície da vedação "T135°C", como está marcado no aparelho, o aparelho não consegue provocar ignição na camada de sujeira (o valor T135°C é baseado na temperatura ambiental máxima.)*

KEMA/ATEX intrinsically safe apparatus (in accordance with CENELEC standards)**Introduction**

Explosion-protected Smart Valve Positioner SVP3000 Alphaplus Models AVP300, AVP301 and AVP302 have been constructed and certified to comply with the CENELEC standards EN 50014, EN 50020, EN 50281-1-1 and EN50284. Be sure to read all applicable laws of your country and local regulations for the installation of equipment for explosive atmospheres.

- EN 50014:1997,
Electrical apparatus for potentially explosive atmospheres-General requirements
- EN 50020:1994,
Electrical apparatus for potentially explosive atmospheres-Intrinsic safety “i”
- EN 50281-1-1:1998,
Electrical apparatus for use in the presence of combustible dust-Part1-1: Electrical apparatus protected by enclosures
- EN 50284:1999,
Special requirements for construction, test and marking of electrical apparatus of equipment group II, category 1 G

Safety information marked on the equipment

AMBIENT TEMP: -40 to +60°C

DATE: (Manufacturing date)



KEMA 00ATEX1111 X

Special conditions for safe use (X)

Refer to the description below.

IP66

YAMATAKE Corporation, KANAGAWA-KEN, 253-0113, JAPAN

Installation, wiring, operation, maintenance and troubleshooting

 **WARNING**

Special conditions for safe use

- The electrical data and intrinsically safe parameters are to be referred to the description under “Specifications” on page xxxi. (Specifications below).
- For application in explosive atmospheres caused by air/dust mixtures-the dust layer may not exceed a thickness of 5 mm,-conduit or cable glands must be selected and used in such a way that a minimum ingress protection of IP6X is guaranteed.

Unauthorized modifications of any part of the enclosure or the internal circuit may invalidate the verified explosion-protection of the Smart Valve Positioner SVP3000 Alphaplus models AVP300, AVP301 and AVP302.

Specifications

Item	Description
Explosion-protection	Intrinsic safety: II 1 G EEx ia IIC T4 Dust ignition protection: II 1 D T135°C for ambient temperature -40 to +60°C
Model AVP300 Electrical data and intrinsically safe parameters	Input circuit (terminals +/-IN) U _i = 30V, I _i = 100 mA (resistively limited), P _i = 1 W C _i = 1 nF, L _i = 0.2 mH Output circuit (terminals +/-OUT) U _i = 10V, I _i = 100 mA (resistively limited), P _i = 1 W C _i = 1 nF, L _i = 0.3 mH Both circuits shall be considered to be connected to ground from a safety point of view.
Model AVP301 Electrical data and intrinsically safe parameters	Input circuit (terminals +/-IN) U _i = 30V, I _i = 100 mA (resistively limited), P _i = 1 W C _i = 1 nF, L _i = 0.2 mH Output circuit (terminals +/-OUT) U _i = 30V, I _i = 100 mA (resistively limited), P _i = 1 W C _i = 3 nF, L _i = 0.2 mH Both circuits shall be considered to be connected to ground from a safety point of view.
Model AVP302 Electrical data and intrinsically safe parameters	Input circuit (terminals +/-IN) U _i = 30V, I _i = 100 mA (resistively limited), P _i = 1 W C _i = 33 nF, L _i = 0.2 mH Output circuit (terminals +/-OUT) U _i = 30V, I _i = 100 mA (resistively limited), P _i = 1 W C _i = 1 nF, L _i = negligibly small Both circuits shall be considered to be connected to ground from a safety point of view.

Dispositif intrinsèquement sûr KEMA/ATEX

(French)

(en conformité avec les standards de CENELEC)

Introduction

Les modèles Alphaplus AVP300, AVP301 et AVP302 du positionneur de vanne intelligent antidéflagrant SVP3000 ont été construits et certifiés conformes aux standards de CENELEC EN 50014, EN 50020, EN 50281-1-1 et EN 50284. Veuillez lire attentivement toutes les lois applicables de votre pays et les règlements régionaux pour l'installation de l'équipement dans un environnement présentant un risque d'explosion.

- EN 50014:1997,
Exigences générales - appareillage électrique pour environnement présentant potentiellement des risques d'explosion
- EN 50020:1994,
Sécurité intrinsèque "i" - appareillage électrique pour environnement présentant potentiellement des risques d'explosion
- EN 50281-1-1:1998,
L'équipement électrique à utiliser en présence de la poussière combustible -
Chapitre 1-1: L'équipement électrique protégé par les coffrets
- EN 50284:1999,
Exigences spécifiques pour la construction, le contrôle et le marquage
d'équipements d'appareillage électrique du groupe II, catégorie 1 G

Information sur la sécurité figurant sur l'équipement

TEMP. AMBIANTE: de -40 à +60° C

DATE: (date de la construction)

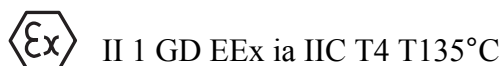

KEMA 00ATEX1111 X

Conditions spécifiques pour utilisation sécurisée (X)

Se référer à la description ci-dessous

IP66

YAMATAKE Corporation, Préfecture de KANAGAWA, 253-0113, JAPON

Installation, câblage, fonctionnement, entretien et diagnostic de défaillance

Avertissement

Conditions spéciales pour une utilisation sûre

- Afin de respecter les données électriques et les paramètres de sécurité intrinsèque, veuillez-vous référer à la description dans “Spécifications” (Spécifications ci-dessous).
- Pour l’application dans un environnement présentant des risques d’explosion provoqués des mélanges air / poussière, la couche de poussières ne doit pas dépasser une épaisseur de 5 mm, les gaines ou les goupilles de câbles doivent être sélectionnées et utilisées de telle manière que la protection minimale de IP6X soit garantie.

Des modifications non autorisées de toute partie du coffret ou du circuit de sortie peuvent infirmer la validité de la protection vérifiée contre les explosions des modèles AVP300, AVP301 et AVP302 du Positionneur de vanne intelligent Alphaplus SVP3000.

Spécifications

Article	Description
Protection contre les explosions	Sécurité intrinsèque: II 1 G EEx ia IIC T4 Protection contre l'inflammation de la poussière: II 1 D T135°C pour température ambiante de -40 à +60°C
Modèle AVP300 Données électriques et paramètres de sécurité intrinsèque	Circuit d'entrée (bornes +/-IN) $U_i = 30V$, $I_i = 100 \text{ mA}$ (limité au niveau de la résistivité), $P_i = 1 \text{ W}$, $C_i = 1 \text{ nF}$, $L_i = 0.2 \text{ mH}$ Circuit de sortie (bornes +/-OUT) $U_i = 10V$, $I_i = 100 \text{ mA}$ (limité au niveau de la résistivité), $P_i = 1 \text{ W}$, $C_i = 1 \text{ nF}$, $L_i = 0.3 \text{ mH}$ Du point de vue de la sécurité, il est recommandé de relier les deux circuits à la terre.
Modèle AVP301 Données électriques et paramètres de sécurité intrinsèque	Circuit d'entrée (bornes +/-IN) $U_i = 30V$, $I_i = 100 \text{ mA}$ (limité au niveau de la résistivité), $P_i = 1 \text{ W}$, $C_i = 1 \text{ nF}$, $L_i = 0.2 \text{ mH}$ Circuit de sortie (bornes +/-OUT) $U_i = 30V$, $I_i = 100 \text{ mA}$ (limité au niveau de la résistivité), $P_i = 1 \text{ W}$, $C_i = 3 \text{ nF}$, $L_i = 0.2 \text{ mH}$ Du point de vue de la sécurité, il est recommandé de relier les deux circuits à la terre.
Modèle AVP302 Données électriques et paramètres de sécurité intrinsèque	Circuit d'entrée (bornes +/-IN) $U_i = 30V$, $I_i = 100 \text{ mA}$ (limité au niveau de la résistivité), $P_i = 1 \text{ W}$, $C_i = 33 \text{ nF}$, $L_i = 0.2 \text{ mH}$ Circuit de sortie (bornes +/-OUT) $U_i = 30V$, $I_i = 100 \text{ mA}$ (limité au niveau de la résistivité), $P_i = 1 \text{ W}$, $C_i = 1 \text{ nF}$, $L_i = \text{infime}$ et peut être négligé Du point de vue de la sécurité, il est recommandé de relier les deux circuits à la terre.

KEMA/ATEX-zertifiziertes eigensicheres Betriebsmittel

(German)

(bescheinigt nach CENELEC-Standards)

Einleitung

Die Modelle AVP300, AVP301 und AVP302 des druckfesten intelligenten Ventilpositionierers SVP3000 Alphaplus wurden in Übereinstimmung mit den CENELEC-Standards EN 50014, EN 50020, EN 50281-1-1 und EN50284 gebaut und zertifiziert. Lesen Sie alle in Ihrem Land und/oder Gebiet anwendbaren Gesetze zur Installation von Geräten in explosionsgefährdeten Bereichen.

- EN 50014:1997,
Elektrische Betriebsmittel für explosionsgefährdete Bereiche - Allgemeine Bestimmungen
- EN 50020:1994,
Elektrische Betriebsmittel für explosionsgefährdete Bereiche - Eigensicherheit "i"
- EN 50281-1-1:1998,
Elektrische Betriebsmittel zur Verwendung in Bereichen mit brennbarem Staub - Teil 1-1: Elektrische Betriebsmittel mit Schutz durch Gehäuse
- EN 50284:1999,
Spezielle Anforderungen an Konstruktion, Prüfung und Kennzeichnung elektrischer Betriebsmittel der Gerätegruppe II, Kategorie 1 G

An der Einrichtung vorhandene Sicherheitsinformationen

AMBIENT TEMP [Umgebungstemperatur]: -40...+60°C

DATE: [Herstellungsdatum]



KEMA 00ATEX1111 X

Special conditions for safe use (X) [Sonderbedingungen für sicheren Einsatz]

Refer to the description below. [Siehe nachfolgende Beschreibung.]

IP66

YAMATAKE Corporation, KANAGAWA-KEN, 253-0113, JAPAN

Installation, Verkabelung, Betrieb, Wartung und Problembehandlung

WARNUNG

Sonderbedingungen für sicheren Einsatz

- Angaben zu elektrischen Daten und Eigensicherheitsparameter finden Sie in der Beschreibung unter "Technische Daten" (nächster Abschnitt).
- Bei Anwendung in durch Luft-Staub-Gemische explosionsgefährdeten Atmosphären darf die Staubschicht eine Dicke von 5 mm nicht überschreiten. Panzerrohr und Kabelschuhe müssen so ausgewählt und verwendet werden, dass ein Mindesteintrittsschutz nach IP6X gegeben ist.

Unzulässige Änderungen an Teilen des Gehäuses oder der internen Gerätekomponenten können die geprüfte Druckfestigkeit der Modelle AVP300, AVP301 und AVP302 des SVP3000 Alphaplus unwirksam machen

Technische Daten

Parameter	Beschreibung
Druckfestigkeit	Eigensicherheit: II 1 G EEx ia IIC T4Staubentzündungssicherheit: II 1 D T135°C (Tamb=-40...+60°C)
Modell AVP300 Elektrische Daten und Eigensicherheitsparameter	Eingangsleitung (Anschlüsse +/-IN) U _i = 30V, I _i = 100 mA (durch Widerstand begrenzt), P _i = 1W, C _i = 1 nF, L _i = 0,2 mH Ausgangsleitung (Anschlüsse +/-OUT) U _i = 10V, I _i = 100 mA (durch Widerstand begrenzt), P _i = 1W, C _i = 1 nF, L _i = 0,3 mH Aus sicherheitstechnischer Sicht sollte ein Anschluss beider Leitungen mit der Erde in Betracht gezogen werden.
Modell AVP301 Elektrische Daten und Eigensicherheitsparameter	Eingangsleitung (Anschlüsse +/-IN) U _i = 30V, I _i = 100 mA (durch Widerstand begrenzt), P _i = 1W, C _i = 1 nF, L _i = 0,2 mH Ausgangsleitung (Anschlüsse +/-OUT) U _i = 30V, I _i = 100 mA (durch Widerstand begrenzt), P _i = 1W, C _i = 3 nF, L _i = 0,2 mH Aus sicherheitstechnischer Sicht sollte ein Anschluss beider Leitungen mit der Erde in Betracht gezogen werden.
Modell AVP302 Elektrische Daten und Eigensicherheitsparameter	Eingangsleitung (Anschlüsse +/-IN) U _i = 30V, I _i = 100 mA (durch Widerstand begrenzt), P _i = 1W, C _i = 33 nF, L _i = 0,2 mH Ausgangsleitung (Anschlüsse +/-OUT) U _i = 30V, I _i = 100 mA (durch Widerstand begrenzt), P _i = 1W, C _i = 1 nF, L _i = vernachlässigbar klein Aus sicherheitstechnischer Sicht sollte ein Anschluss beider Leitungen mit der Erde in Betracht gezogen werden.

Aparato intrínsecamente seguro KEMA/ATEX

(Spanish)

(de acuerdo con los estándares CENELEC)

Introducción

Posicionador de Válvula Inteligente protegido contra Explosiones SVP3000
Alphaplus Modelos AVP300,

AVP301 y AVP302 han sido construidos y certificados para cumplir con los estándares CENELEC EN 50014, EN 50020, EN 50281-1-1 y EN50284. Asegúrese de leer todas las leyes pertinentes de su país así como las normas locales para la instalación del equipo en atmósferas explosivas.

- EN 50014:1997,
Aparato eléctrico para atmósferas potencialmente explosivas-Requisitos generales
- EN 50020:1994,
Aparato eléctrico para atmósferas potencialmente explosivas-Seguridad intrínseca "i"
- EN 50281-1-1:1998,
Aparato eléctrico para uso en presencia de polvo de combustible-Parte 1-1: Aparato eléctrico protegido por recintos
- EN 50284:1999,
Requisitos especiales para la construcción, prueba y marcado de aparato eléctrico de grupo de equipo II, categoría 1 G

Información sobre seguridad marcada sobre el equipo

TEMP. AMBIENTE: -40 a +60° C

FECHA: (Fecha de fabricación)



KEMA 00ATEX1111 X

Condiciones especiales para su uso seguro (X)

Consultar la descripción a continuación.

IP66

YAMATAKE Corporation, KANAGAWA-KEN, 253-0113, JAPÓN

Instalación, cableado, funcionamiento, mantenimiento y resolución de problemas

ADVERTENCIA

Condiciones especiales para el uso seguro

- Los datos eléctricos y los parámetros intrínsecamente seguros se deben referir a la descripción bajo “Especificaciones” (Especificaciones a continuación).
- Para la aplicación en atmósferas explosivas causadas por mezclas de aire/polvo- La capa de polvo no puede superar un grosor de 5 mm,-el conducto o las pasatapas se tienen que seleccionar y utilizar de tal modo que se garantice una protección mínima de IP6X contra entrada.

Las modificaciones no autorizadas de cualquier pieza del recinto o del circuito interno pueden invalidar la protección contra explosión verificada del Posicionador de Válvula Inteligente SVP3000 Alphaplus modelos AVP300, AVP301 y AVP302.

Especificaciones

Artículo	Descripción
Protección contra explosión	Seguridad intrínseca: II 1 G EEx ia IIC T4 Protección de ignición de polvo: II 1 D T135°C para temperatura ambiente de -40 a +60°C
Modelo AVP300 Datos eléctricos y parámetros intrínsecamente seguros	Circuito de entrada (terminales +/-ENTRADA) $U_i = 30V$, $I_i = 100 \text{ mA}$ (limitado por resistencia), $P_i = 1W$, $C_i = 1 \text{ nF}$, $L_i = 0,2 \text{ mH}$ Circuito de salida (terminales +/-SALIDA) $U_i = 10V$, $I_i = 100 \text{ mA}$ (limitado por resistencia), $P_i = 1W$, $C_i = 1 \text{ nF}$, $L_i = 0,3 \text{ mH}$ Ambos circuitos se considerarán conectados a tierra desde el punto de vista de seguridad.
Modelo AVP301 Datos eléctricos y parámetros intrínsecamente seguros	Circuito de entrada (terminales +/-ENTRADA) $U_i = 30V$, $I_i = 100 \text{ mA}$ (limitado por resistencia), $P_i = 1W$, $C_i = 1 \text{ nF}$, $L_i = 0,2 \text{ mH}$ Circuito de salida (terminales +/-SALIDA) $U_i = 30V$, $I_i = 100 \text{ mA}$ (limitado por resistencia), $P_i = 1W$, $C_i = 3 \text{ nF}$, $L_i = 0,2 \text{ mH}$ Ambos circuitos se considerarán conectados a tierra desde el punto de vista de seguridad.
Modelo AVP302 Datos eléctricos y parámetros intrínsecamente seguros	Circuito de entrada (terminales +/-ENTRADA) $U_i = 30V$, $I_i = 100 \text{ mA}$ (limitado por resistencia), $P_i = 1W$, $C_i = 33 \text{ nF}$, $L_i = 0,2 \text{ mH}$ Circuito de salida (terminales +/-SALIDA) $U_i = 30V$, $I_i = 100 \text{ mA}$ (limitado por resistencia), $P_i = 1W$, $C_i = 1 \text{ nF}$, $L_i =$ insignificamente pequeño Ambos circuitos se considerarán conectados a tierra desde el punto de vista de seguridad.

Apparecchi intrinsecamente sicuri a norme KEMA/ATEX

(Italian)

(in conformità alle norme CENELEC)

Introduzione

I posizionatori di valvole intelligenti a protezione da esplosione SVP3000 Alphaplus, modelli AVP300, AVP301 e AVP302, sono stati realizzati e certificati per ottemperare alle norme CENELEC EN 50014, EN 50020, EN 50281-1-1 ed EN50284. Prima di installare attrezzature per atmosfera esplosiva si raccomanda di leggere tutte le leggi e i regolamenti applicabili del proprio Paese.

- EN 50014:1997,
Apparati elettrici per atmosfera potenzialmente esplosiva - Requisiti generali
- EN 50020:1994,
Apparati elettrici per atmosfera potenzialmente esplosiva - Sicurezza intrinseca "i"
- EN 50281-1-1:1998,
Apparati elettrici utilizzati in presenza di polveri combustibili - Parte 1: Apparati elettrici protetti da involucri
- EN 50284:1999,
Requisiti speciali per la costruzione, la prova e la marcatura di apparecchi elettrici impiegati in attrezzature appartenenti al gruppo II, categoria 1 G

Informazioni di sicurezza marcate sull'apparecchio

AMBIENT TEMP: -40 to +60°C

DATE: (data di costruzione)



KEMA 00ATEX1111 X

Condizioni particolari per l'impiego in sicurezza (X)

Si prega di fare riferimento alla descrizione che segue.

IP66

YAMATAKE Corporation, KANAGAWA-KEN, 253-0113, JAPAN

Installazione, cablaggio, funzionamento, manutenzione e risoluzione dei problemi

ATTENZIONE

Condizioni particolari per l'impiego in sicurezza

- Per i dati elettrici e i parametri di sicurezza intrinseca si prega di fare riferimento alle descrizioni fornite nella sezione "Specifiche" (Le specifiche più oltre riportate).
- Per applicazioni in atmosfera esplosiva caratterizzata dalla presenza di miscele di aria/polveri (lo strato delle polveri non deve tuttavia eccedere 5 mm di spessore), le tenute delle condotte o dei cavi devono essere selezionate ed impiegate in modo tale da garantire una protezione di ingresso minima in classe IP6X.

Modifiche non autorizzate a qualsivoglia parte dell'involucro o della circuiteria interna può vanificare la protezione da esplosione verificata del posizionatore di valvole intelligente SVP3000 Alphaplus, modelli AVP300, AVP301 e AVP302.

Specifiche

Elemento	Descrizione
Protezione da esplosione	Sicurezza intrinseca: II 1 G EEx ia IIC T4 Protezione dall'accensione delle polveri: II 1 D T135°C per temperatura ambiente da -40 a +60°C
Modello AVP300 Dati elettrici e parametri di sicurezza intrinseca	Circuito di ingresso (terminali +/-IN) $U_i = 30V$, $I_i = 100 \text{ mA}$ (a limitazione di resistenza), $P_i = 1W$, $C_i = 1 \text{ nF}$, $L_i = 0,2 \text{ mH}$ Circuito di uscita (terminali +/-OUT) $U_i = 10V$, $I_i = 100 \text{ mA}$ (a limitazione resistiva), $P_i = 1W$, $C_i = 1 \text{ nF}$, $L_i = 0,3 \text{ mH}$ Per questioni di sicurezza si consideri di collegare entrambi i circuiti a terra.
Modello AVP301 Dati elettrici e parametri di sicurezza intrinseca	Circuito di ingresso (terminali +/-IN) $U_i = 30V$, $I_i = 100 \text{ mA}$ (a limitazione resistiva), $P_i = 1W$, $C_i = 1 \text{ nF}$, $L_i = 0,2 \text{ mH}$ Circuito di uscita (terminali +/-OUT) $U_i = 30V$, $I_i = 100 \text{ mA}$ (a limitazione resistiva), $P_i = 1W$, $C_i = 3 \text{ nF}$, $L_i = 0,2 \text{ mH}$ Per questioni di sicurezza si consideri di collegare entrambi i circuiti a terra.
Modello AVP302 Dati elettrici e parametri di sicurezza intrinseca	Circuito di ingresso (terminali +/-IN) $U_i = 30V$, $I_i = 100 \text{ mA}$ (a limitazione resistiva), $P_i = 1W$, $C_i = 33 \text{ nF}$, $L_i = 0,2 \text{ mH}$ Circuito di uscita (terminali +/-OUT) $U_i = 30V$, $I_i = 100 \text{ mA}$ (a limitazione resistiva), $P_i = 1W$, $C_i = 1 \text{ nF}$, $L_i = \text{trascurabile}$ Per questioni di sicurezza si consideri di collegare entrambi i circuiti a terra.

KEMA/ATEX intrinsiek veilig apparaat

(in overeenstemming met de CENELEC normen)

(Dutch)

Inleiding

De explosieveilige Smart Valve Positioner SVP3000 Alphaplus Modellen AVP300, AVP301 en AVP302 zijn gebouwd en gecertificeerd in overeenstemming met de CENELEC standaarden EN50014, EN 50020, EN 50281-1-1 en EN 50284. Gelieve alle toepasselijke landelijke wetgeving en lokale regelgeving voor toestellen in explosieve atmosfeer te lezen.

- EN 50014:1997
Elektrische apparaten voor eventueel explosieve atmosfeer - Algemene vereisten
- EN50020:1994
Elektrische apparaten voor eventueel explosieve atmosfeer - Intrinsieke veiligheid "i"
- EN50281-1-1:1998
Elektrische apparaten voor gebruik in de aanwezigheid van ontvlambaar stof - Deel 1-1: Elektrische apparaten, beschermd door behuizingen
- EN50284:1999
- Speciale vereisten voor het bouwen, testen en markeren van elektrische apparaten van toestelgroep II, categorie 1 G

Veiligheidsinformatie aangebracht op het toestel

OMGEVINGS TEMP: -40 tot +60°C

DATUM: (fabricagedatum)



KEMA 00ATEX1111 X

Speciale voorwaarden voor veilig gebruik (X)

Zie beschrijvingen hieronder.

IP66

YAMATAKE Corporation, KANAGAWA-KEN, 253-0113 JAPAN

Installatie, bedrading, gebruik, onderhoud en probleemaafhandeling

WAARSCHUWING

Speciale voorwaarden voor veilig gebruik

- Voor de elektrische gegevens en de intrinsiek veilige parameters wordt verwezen naar “Specificaties” (Specificaties hieronder).
- Voor toepassing in een explosieve atmosfeer veroorzaakt door lucht/stof mengsels, mag de dikte van de stoflaag de 5mm niet overschrijden. Pijp- of kabelpakkingsbussen moeten gekozen en gebruikt worden zodanig dat een minimale indringingsbeveiliging van IP6X verzekerd is.

Niet-geautoriseerde veranderingen aan eender welk deel van de behuizing of de interne schakeling kan de geverifieerde explosiebeveiliging van de Smart Valve Positioner SVP3000 Alphaplus modellen AVP300, AVP301 en AVP302 ongeldig maken.

Specificaties

Onderwerp	Beschrijving
Explosieveiligheid	Intrinsieke veiligheid: II 1 G EEx ia IIC T4Stofontvlammingsbeveiliging: II 1 D T135°C voor een omgevingstemperatuur van -40 tot + 60°C
Model AVP300 Elektrische gegevens en parameters voor intrinsieke veiligheid	Ingangsschakeling (terminalen +/-IN) U _i =30V, I _i =100mA (weerstandsbepert), P _i =1W, C _i =1nF, L _i =0.2mH Uitgangsschakeling (terminalen +/-OUT) U _i =10V, I _i =100mA (weerstandsbepert), P _i =1W, C _i =1nF, L _i =0.3mH Vanuit veiligheidsoogpunt dienen beide schakelingen beschouwd te worden als verbonden met de aarde.
Model AVP301 Elektrische gegevens en parameters voor intrinsieke veiligheid	Ingangsschakeling (terminalen +/-IN) U _i =30V, I _i =100mA (weerstandsbepert), P _i =1W, C _i =1nF, L _i =0.2mH Uitgangsschakeling (terminalen +/-OUT) U _i =30V, I _i =100mA (weerstandsbepert), P _i =1W, C _i =3nF, L _i =0.2mH Vanuit veiligheidsoogpunt dienen beide schakelingen beschouwd te worden als verbonden met de aarde.
Model AVP302 Elektrische gegevens en parameters voor intrinsieke veiligheid	Ingangsschakeling (terminalen +/-IN) U _i =30V, I _i =100mA (weerstandsbepert), P _i =1W, C _i =33nF, L _i =0.2mH Uitgangsschakeling (terminalen +/-OUT) U _i =30V, I _i =100mA (weerstandsbepert), P _i =1W, C _i =1nF, L _i =verwaarloosbaar klein Vanuit veiligheidsoogpunt dienen beide schakelingen beschouwd te worden als verbonden met de aarde.

Aparelho seguro de forma intrínseca KEMA/ATEX

(Portuguese)

(Conforme o padrão CENELEC)

Introdução

Os modelos AVP300, AVP301 e AVP302 do Posicionador de Válvula Inteligente Protegido contra Explosão Alphaplus SVP3000 foram projetados e certificados de acordo com os padrões EN 50014, EN 50020, EN 50281-1-1 e EN 50284 da CENELEC. Certifique-se de ler todas as leis aplicáveis do seu país e regulamentos locais para a instalação de equipamentos em atmosferas explosivas.

- EN 50014/1997:
Aparelho elétrico para atmosferas potencialmente explosivas - Condições gerais
- EN 50020/1994:
Aparelho elétrico para atmosferas potencialmente explosivas - Segurança intrínseca "i"
- EN 50281-1-1/1998:
Aparelho elétrico para uso em presença de sujeiras combustíveis - Parte 1-1:
Aparelho elétrico protegido por vedações
- EN 50284/1999:
Condições especiais para a construção, teste e marcação de aparelho elétrico do equipamento do grupo II, categoria 1 G

Informações sobre segurança marcadas no equipamento

TEMPERATURA AMBIENTE: -40 a +60°C

DATA: (Data de fabricação)



KEMA 00ATEX1111 X

Condições especiais para uma utilização segura (X)

Consultar a descrição abaixo.

IP66

YAMATAKE Corporation, KANAGAWA-KEN, 253-0113, JAPÃO

Instalação, fiação, operação, manutenção e resolução de problemas

CUIDADO

Condições especiais para uma utilização segura

- Os dados elétricos e parâmetros seguros de forma intrínseca devem ser consultados na descrição das “Especificações” (Especificações abaixo)
- Para aplicação em atmosferas explosivas causadas pela mistura de ar/sujeira - a camada de sujeira não pode exceder a espessura de 5 mm -, os conduítes ou juntas de cabos devem ser selecionados e usados de forma que seja garantida a proteção mínima de entrada de IP6X.

Modificações não-autorizadas em qualquer parte da vedação do circuito interno podem invalidar a proteção contra explosão que ocorrer no Posicionador de Válvula Inteligente Alphaplus SVP 3000, modelos AVP300, AVP301 e AVP302.

Especificações

Item	Descrição
Proteção contra explosão	Segurança intrínseca: II 1 G EEx ia IIC T4 Proteção contra ignição por sujeira: II 1 D T135°C para temperatura ambiente de -40 a +60°C
Modelo AVP300 Dados elétricos e parâmetros de segurança intrínsecos	Circuito de entrada (terminais +/-IN) $U_i = 30V$, $I_i = 100mA$ (limitado em termos de resistência), $P_i = 1W$, $C_i = 1 nF$, $L_i = 0,2 mH$ Circuito de saída (terminais +/-OUT) $U_i = 10V$, $I_i = 100mA$ (limitado em termos de resistência), $P_i = 1W$, $C_i = 1 nF$, $L_i = 0,3 mH$ Ambos os circuitos devem ser considerados que serão conectados à terra, do ponto de vista de segurança.
Modelo AVP301 Dados elétricos e parâmetros de segurança intrínsecos	Circuito de entrada (terminais +/-IN) $U_i = 30V$, $I_i = 100mA$ (limitado em termos de resistência), $P_i = 1W$, $C_i = 1 nF$, $L_i = 0,2 mH$ Circuito de saída (terminais +/-OUT) $U_i = 30V$, $I_i = 100mA$ (limitado em termos de resistência), $P_i = 1W$, $C_i = 3 nF$, $L_i = 0,2 mH$ Ambos os circuitos devem ser considerados que serão conectados à terra, do ponto de vista de segurança.
Modelo AVP302 Dados elétricos e parâmetros de segurança intrínsecos	Circuito de entrada (terminais +/-IN) $U_i = 30V$, $I_i = 100mA$ (limitado em termos de resistência), $P_i = 1W$, $C_i = 33 nF$, $L_i = 0,2 mH$ Circuito de saída (terminais +/-OUT) $U_i = 30V$, $I_i = 100mA$ (limitado em termos de resistência), $P_i = 1W$, $C_i = 1 nF$, $L_i =$ insignificante Ambos os circuitos devem ser considerados que serão conectados à terra, do ponto de vista de segurança.

NEPSI Flameproof apparatus

$$\frac{\text{Ex}}{1} \frac{\text{d}}{2} \frac{\text{IIC}}{3} \frac{\text{T6}}{4} \text{ DIP A20 T6}$$

- 1: With NEPSI (National Supervision and Inspection Center for Explosion Protection and Safety of Instrumentation)
- 2: Flameproof
- 3: Explosive gas atmosphere classified in IIC
- 4: Gas atmosphere of which the ignition temperature is 85°C or greater

Ambient temperature: -40°C to +60°C

WARNING

Do not open the terminal cover while the SVP is in operation. Do not open the terminal cover nor loosen the screws that fasten the angle sensor to the SVP unit. Doing so may cause ignition of the explosive atmosphere.

WARNING

The cable gland must be placed in the signal wire entry of the apparatus. Make sure to use a NEPSI certified cable gland conforming to EExd IIC and 1/2NPT or M20 × 1.5 screws.

The specified type of protection cannot be guaranteed if any of the above precautions are ignored. Make sure that the earthing terminal outside of the apparatus is properly grounded.

Prevent corrosion, deformation or damage to the housing or the terminal box cover. Screw the cover-fastening screw tightly. Do not open the cover while the apparatus is in operation.

Be sure to read the user's manual before installation, operation and maintenance. For wiring, observe all the regulations and guidelines prescribed by "Electrical Installation Design Code for Explosive Atmosphere, People's Republic of China" (GB50058-1992).

NEPSI Intrinsically safe apparatus

Intrinsically Safe Ex ia IIC T4-T6

T4 at -40°C to +80°C

T5 at -40°C to +60°C

T6 at -40°C to +40°C

Maximum electrical parameters

Positioner circuit:

$V_i = 30V$, $I_i = 95 \text{ mA}$, $P_i = 0.66 \text{ W}$, $C_i = 0$, $L_i = 0.2 \text{ mH}$

Transmitter circuit (only model AVP301):

$V_i = 30V$, $I_i = 95 \text{ mA}$, $P_i = 0.66 \text{ W}$, $C_i = 0$, $L_i = 0.2 \text{ mH}$

Maximum allowed cable capacitance

0.06 μF

Maximum allowed cable inductance

1 mH

WARNING

NEPSI's specific requirements:

The intrinsically safe type SVP should be used with the following zener barriers:

Model AVP300: Two each of MTL728, Z728, or LB928

Model AVP301: For input signal - Two each of MTL728, Z728, or LB928

For valve travel transmitter - MTL787S, Z787, or LB987S

Refer to the user's manual of each applicable barrier along with this manual.

The wiring capacitance should be less than 0.06 μF .

The wiring inductance should be less than 1mH.

Using the earthing terminal to properly ground it.

Prevent corrosion, deformation, or damage to the housing or the terminal box cover.

Close the cover and securely tighten the fastening screw. Never open the cover while it is in operation.

Be sure to read the manual before installation, operation, and maintenance. For wiring, observe all the codes and regulations (GB3836, 15-2000, GB50058-1992) prescribed by the Electric Safety Code for Explosion-proof in the People's Republic of China.

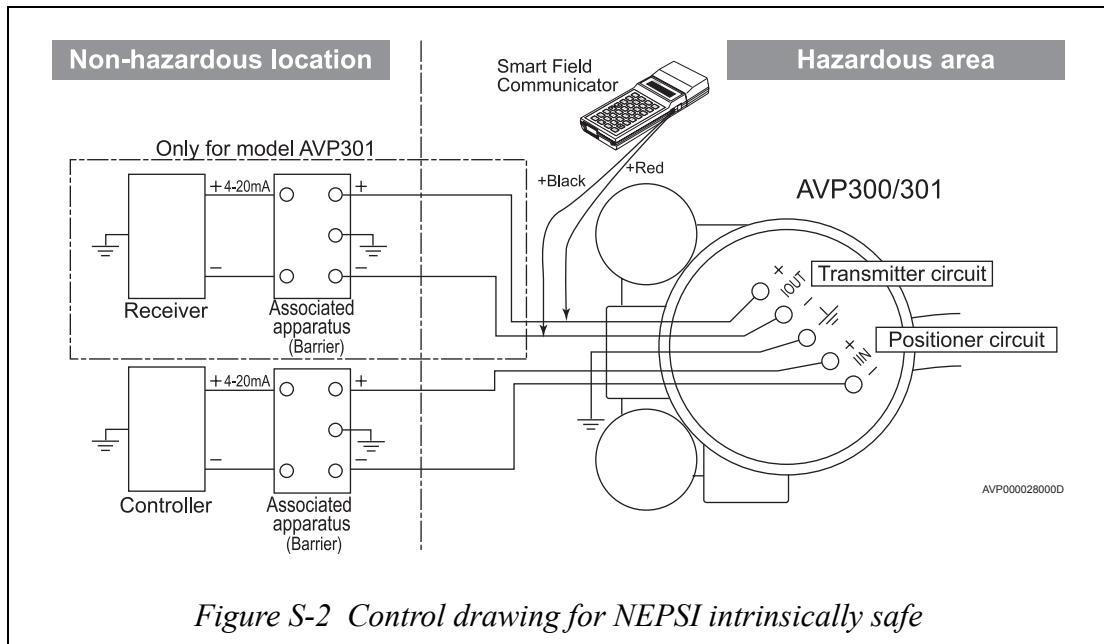

~Note 1) *Maximum electrical parameters:*

Positioner circuit: $V_i = 30V$, $I_i = 95\text{ mA}$, $P_i = 0.66W$, $C_i = 0.2\text{ mH}$

Transmitter circuit (for model AVP301 model): $V_i = 30V$, $I_i = 95\text{ mA}$, $P_i = 0.66W$, $C_i=0$, $L_i = 0.2\text{ mH}$

2) *Smart Field Communicator (SFC) may be connected at any point in the loop between the associated apparatus and the model AVP301. There must be a minimum series resistance of 250Ω between the SFC connection point and power supply (RECEIVER).*

In the case of model AVP300, SFC can be connected directly at the terminals (IOUT/SFC).

3) *Installation of the associated apparatus shall comply with the manufacturer's instruction of the associated apparatus.*

Upon receiving the unit

Handle with care to prevent damage. Check that the following items are included:

- SVP3000 Alphaplus Smart Valve Positioner model AVP300, AVP301, AVP302, AVP200, AVP201, or AVP202
- Feedback lever and 2 hex socket bolts
- Hex wrench for feedback and terminal box cover
- Any accessories that were ordered
- Manual (option)

Verifying the Specifications

The SVP3000 Alphaplus specifications are written on the name plate on the body of the positioner itself. Compare these specifications to those in the appendix, and verify that the SVP3000 Alphaplus matches your order. In particular, be sure to check the following items.

- Tag number (TAG NO.)
- Model number (MODEL)
- Factory number (PROD.)
- Input current range (INPUT)
- Air supply pressure (SUPPLY)
- Explosionproof inspection passage award (for positioners with explosionproof specifications)

Inquiries

If you have any questions about the specifications, please contact the office listed at the back of this user's manual. Have the model number (MODEL) and factory number (PROD.) number ready when you call in your question.

Storage

Ideally, the SVP should be stored in the original packaging. However, if the original packaging is not available, store the SVP indoors at normal temperature (25°C {77°F}) and humidity (~ 65%) in a place free from vibration and shock and not exposed to rain or water. If you are storing the SVP after it has been used, clean the SVP and then firmly tighten the terminal box cover and seal the wiring, piping connections and bleed hole in the pilot cover using the Yamatake-supplied caps or tape to prevent entry of moisture.

Table of Contents

Chapter 1: Introduction

1-1: SVP models	1-1
1-2: System structures	1-2
Without position transmission output (Models AVP300 and AVP200).....	1-2
Position transmission output (Models AVP301 and AVP201)	1-2
Analog output	1-2
DE protocol.....	1-3
HART communication (Models AVP302 and AVP202)	1-4
1-3: Communication.....	1-5
Manual communication.....	1-5
Using a Smart Field Communicator (SFC)	1-5
Using a HART communicator	1-5
1-4: Structures and functions of SVP.....	1-6
Main components	1-6
Integral type (model AVP300/301/302)	1-6
Remote type (model AVP200/201/202).....	1-7
Terminal box.....	1-9

Chapter 2: Installation

2-1: Site Selection.....	2-1
2-2: Installing SVP	2-1
Examples	2-3
With HA1 actuator	2-3
With HA2~4, PSA1~4, 6, VA1~6 actuators	2-3
Connecting the feedback pin and the feedback lever.....	2-4
Space allowance for maintenance.....	2-5
Connecting the air supply	2-5
Pressure regulator with filter.....	2-5
Shutoff valve.....	2-6
Recommended piping practices	2-6
2-3: Installing a remote type SVP (Model AVP200/201/202).....	2-7
Disconnecting the positioner body and remote cable	2-7
Connecting the positioner body and remote cable	2-8
Length adjustment of remote cable	2-9
Connecting the SVP and feedback cable	2-10
Changing the feedback lever direction	2-10
Attaching the valve travel detector to an actuator.....	2-11
Installing the SVP main unit.....	2-12
Note for cable wiring between travel detector and SVP main unit.....	2-12
2-4: Installing a double-acting SVP for springless actuators.....	2-13
Reversing relay.....	2-13
Installing the relay.....	2-13
Installing a double-acting SVP with a KZ03 air pressure regulator with filter	2-15
Installing a double-acting SVP without an air pressure regulator	2-16
Procedure for air pipe connection.....	2-17
Installing a double-acting SVP onto diaphragm actuator.....	2-18
Installing a double-acting SVP onto a rotary actuator.....	2-18
2-5: Electrical wiring.....	2-19
Wiring for waterproof SVP	2-19
Connection points.....	2-19
Electrical wiring types.....	2-19

Table of Contents

Electrical wiring without travel transmitter (Model AVP300/302/200/202)	2-20
With travel transmitter (Model AVP301/201)	2-20
Cables	2-22
Electrical wiring procedure	2-23
Wiring for explosionproof SVP	2-24
Guidelines	2-24
Locking	2-24
Leading in external cables	2-24
Wiring for Intrinsically-safe SVP	2-25
Guidelines	2-25
Wiring	2-25
Configuration of an intrinsically-safe system	2-26
2-6: Control signal	2-27
2-7: Travel transmission and load resistance	2-27
2-8: Cable gland and flameproof universal elbow for JIS Flameproof apparatus	2-27
Structure of the flameproof cable gland	2-28
Structure of the flameproof universal elbow	2-28
Mounting example	2-29
Mounting procedure for flameproof cable gland	2-30
Mounting procedure for flameproof universal elbow	2-31
Lead-in of cable for flameproof models other than models in accordance with JIS	2-31

Chapter 3: Operation

3-1: Auto-setup	3-1
SVP setting	3-2
To initiate auto-setup using the external switch	3-4
3-2: Zero-Span adjustment	3-6
Zero-Span adjustment using external switch	3-7
Procedure to adjust valve to fully shut position (zero)	3-7
Procedure to adjust valve to fully open position (span)	3-7
Adjustment direction	3-8
3-3: Starting operation	3-9
Items to verify before setup	3-9
Verification procedure	3-9
Verifying the operation	3-10
Verifying EPM (Electro-pneumatic converter module) operation	3-10
Verifying self diagnostics	3-10
Verifying SVP operation	3-10
Operation startup procedure	3-11
Stopping operation	3-11

Chapter 4: Configuration using a SFC

4-1: SFC functions	4-1
4-2: Using the SFC with software versions earlier than version 7.5	4-3
Position transmission output range setting	4-3
Limit value setting (LIMIT CONFIG)	4-3
Setting the position transmission output damping time constant (DAMP)	4-3
4-3: Connecting the SFC	4-4
Types of wiring	4-4
When the position transmission function is not installed	4-4
When the position transmission function is installed	4-5
4-4: Relationship between the mode and data settings	4-6
SVP mode and SVT mode	4-6
Mode display	4-6
Modes and functions	4-6
Mode switching procedures	4-7
4-5: Starting communications	4-8
Before starting communications	4-8
4-6: Registering and changing the tag number	4-9
4-7: Function setup and modification	4-10
Hierarchical CONFIG structure	4-10
Notes on configuration settings	4-10
Basic procedure for configuration settings	4-11
If an out of range value is entered	4-12
If a communication error occurs during confirmed data registration (transfer)	4-12
4-8: Starting and stopping configuration [SVP/SVT]	4-13
(A) Basic data settings (SYSTEM CONFIG)	4-14
Flowchart for SYSTEM CONFIG	4-14
(1) Actuator operation selection (ACTUATOR ACTION)	4-15
(2) Positioner operation selection (POSI. ACTION)	4-15
(3) Valve operation selection (VALVE ACTION)	4-15
(4) Actuator size selection (ACTUATOR SIZE)	4-15
(5) Hysteresis selection (HYSTERESIS)	4-16
(6) PID data printout (PID DATA PRINT)	4-17
(B) Dynamic characteristics data settings (CTL CONFIG)	4-18
Flowchart for CTL CONFIG	4-18
Gap-action type PID	4-19
Parameter descriptions	4-19
(C) Flow characteristics selection (CONFORM CONFIG)	4-20
Flowchart for CONFORM CONFIG	4-20
Types of flow characteristics	4-21
(D) Flow characteristics conversion data settings (CNV CONFIG)	4-22
Flowchart for CNV CONFIG	4-22
Flow characteristics conversion data	4-23
Printing the characteristics curve	4-23
Examples	4-24
Flow Characteristics Examples	4-24
(E) Forced fully open and fully closed settings (ON/OFF CONFIG)	4-25
Flowchart for ON/OFF CONFIG	4-25
Forced fully open/fully closed settings	4-26
(G) SVP internal temperature display	4-26
Flowchart for SENSOR TEMP	4-26
(H) Maintenance mode (MAINTE MODE)	4-27

Table of Contents

Flowchart for MAINTÉ MODE	4-27
(1) Auto setup	4-28
(2) PROM number display (PROM NO.)	4-29
(3) Save settings data (USER DATA SAVE)	4-29
(4) Restore default data (INIT DATA RECOV)	4-29
(I) Zero-span adjustment	4-30
Using SFC with input signal	4-30
Using SFC with supply air	4-35
4-9: Setting and adjusting the current input range [SVP/SVT]	4-39
Procedure for setting up an arbitrary current input value	4-39
Procedure for setting up an actual current input value	4-41
4-10: IIN/VTD simultaneous ranging [SVP/SVT]	4-43
Procedure for setting the current input value and position	4-43
4-11: Verifying operating data	4-45
Verifying the current input value [SVP]	4-45
Verifying the position [SVP]	4-46
Verifying the EPM (Electro-Pneumatic converter Module) drive signals [SVT]	4-46
Verifying the position transmission output value [SVT]	4-47
Self diagnostics [SVP/SVT]	4-47
4-12: Data Printing	4-48
Printing function overview	4-48
Printing functions	4-48
Printer	4-48
Paper feed	4-48
Replacing the paperroll	4-48
Configuration Printout (Verifying all data at once) [SVP/SVT]	4-49
Configuration printout example	4-50
Continuous Response Printout (Action Print) [SVP/SVT]	4-51
4-13: Other functions	4-52
Current input correction (IIN CORRECT)	4-52
Current output correction (IOUT CORRECT)	4-54
Simulated current input [SVP]	4-58
Setting the simulated current input value	4-58
Releasing the stored current input value	4-59
EPM simulated drive signal setting [SVT]	4-60
Setting the EPM simulated drive signal	4-60
Canceling the registered simulated signal	4-61
Simulated position transmission output [SVT]	4-62
Setting the simulated position transmission output value	4-62
Canceling the registered output value	4-63
Restoring factory data [SVP/SVT]	4-64
Switching between analog and digital output [SVP/SVT]	4-65
Setting the digital output format [SVP/SVT]	4-66
Digital (DE) output format	4-66
Output signal mode setting	4-66
Amount of information mode setting	4-66
Failsafe mode setting	4-66

Chapter 5: Configuration using a HART Communicator

5-1: HART communicator functions	5-2
5-2: Starting communication	5-4
Before starting communication	5-4
Procedure	5-4
5-3: Verifying and modifying the general information.....	5-6
Device information	5-6
Manufacturer.....	5-7
5-4: Device condition	5-8
Current input value (units: mA).....	5-8
Input signal% (percentage) value (units:%).....	5-8
Valve travel (units:%).....	5-8
Drive sig (EPM (Electro Pneumatic converter Module) drive signal) (units:%).....	5-8
Temperature (Equipment internal temperature) (units: °C)	5-8
Last config data	5-9
0% tvl angle (VTD sensor angle when fully closed) (units: degrees)	5-9
100% tvl angle (VTD sensor angle when fully open) (units: degrees).....	5-9
Stroke time (units: seconds).....	5-9
Hysteresis rate (units:%)	5-9
5-5: Config & Calib (Equipment setup and calibration).....	5-10
Mode (Switching the SVP mode).....	5-10
Input signal range (Setting the current input values).....	5-10
Valve sys config (Valve system configuration)	5-11
Actuator action.....	5-11
Valve action.....	5-11
Positioner action.....	5-11
Dynamic chara (Dynamic characteristics)	5-12
Actuator size.....	5-12
Gland packing.....	5-12
Gap PID param (Gap PID parameters)	5-13
Valve chara (Valve characteristics)	5-14
Select chara form	5-14
Chara data.....	5-14
Tvl cut off (Travel cut off).....	5-15
Forced fully open/fully closed settings.....	5-15
Procedure	5-16
Calibrate	5-16
Diag parameters (Diagnostic parameters).....	5-17
1. Stick Slip.....	5-17
2. Total Stroke	5-18
3. Cycle Count.....	5-18
4. Tvl Histogram (Travel Histogram).....	5-19
5. 0% Tvl Error (0% Travel Error).....	5-19
6. Shut-Off Cnt (Shut-Off Count).....	5-20
7. Max. Tvl Speed (Maximum Travel Speed)	5-21
8. Deviation Alarm	5-22
9. Temp Alarm (Temperature alarm).....	5-23
Burst mode	5-24
5-6: Initial setup.....	5-25
Auto setup	5-25
5-7: Maintenance	5-26
Dummy input sig (Dummy input signal).....	5-26

Table of Contents

Dummy drive sig (Dummy drive signal)	5-26
User data save	5-27
Correct reset	5-27
5-8: Device status	5-28
Failures	5-28
Notices	5-28
Valve diagnostics	5-29
Alarms	5-29
Parameters status	5-29

Chapter 6 : Maintenance

6-1: Auto/Manual selection switch	6-1
Automatic operation	6-1
Manual operation	6-1
Procedure to change from automatic operation to manual operation	6-2
Procedure to change from manual operation to automatic operation	6-2
6-2: Filter replacement and restriction maintenance	6-3
Procedure	6-3
6-3: Cleaning the flapper	6-4
6-4: EPM (Electro-pneumatic Converter Module) balance adjustment	6-4
6-5: Insulation Resistance Test	6-6
Test procedures	6-6
Judgment criteria	6-6
6-6: Adjustment procedure when using the SVP attached to the booster relay	6-7
6-7: Table of default internal data values	6-8
6-8: SVP internal block diagram and SVP I/O flow	6-9
6-9: Replacement parts	6-11

Chapter 7: Troubleshooting

7-1: Using an SFC	7-1
7-2: Using a HART Communicator	7-2
7-3: General troubleshooting	7-2
SVP does not operate (no output air pressure)	7-2
Abnormal action of control valve (although output air is supplied, the control valve does not operate properly):	7-3
No communication possible with an SFC or HART Communicator:	7-4
Troubleshooting Codes	7-4
SFC message documentation (Communication and SFC problems)	7-5

List of Figures & Tables

<Figures>

Figure S-1	Maximum distance between sealing fitting and SVP	iii
Figure S-2	Control drawing for NEPSI intrinsically safe.....	xlvi
Figure 1-1	SVP overview	1-1
Figure 1-2	System structure with no output	1-2
Figure 1-3	Analog output system structure (model AVP301/201)	1-2
Figure 1-4	Digital output system structure.....	1-3
Figure 1-5	HART communication structure (model AVP302/202).....	1-4
Figure 1-6	Yamatake Smart Field Communicator	1-5
Figure 1-7	Front view.....	1-6
Figure 1-8	Back view	1-6
Figure 1-9	Front view of SVP remote type	1-7
Figure 1-10	Structure of terminal box	1-9
Figure 1-11	Terminal block.....	1-9
Figure 2-1	Mounting on HA1 actuator	2-3
Figure 2-2	Mounting on HA2~4, PSA1~6, VA1~6	2-3
Figure 2-3	Feedback pin and feedback lever connection	2-4
Figure 2-4	Angle between feedback lever and pin	2-4
Figure 2-5	Feedback lever maximum range of motion	2-4
Figure 2-6	Attach the feedback lever (with extension)	2-4
Figure 2-7	Typical air supply system	2-5
Figure 2-8	Open a cover of terminal box for remote cable assembly	2-7
Figure 2-9	Terminal box for remote cable assembly and wiring of the cover back side of terminal box.....	2-8
Figure 2-10	Remote cable structure	2-9
Figure 2-11	Disassembling the feedback lever	2-10
Figure 2-12	Example for mounting the rotary cylinder actuator on SVP (remote type).....	2-11
Figure 2-13	Pole mounted SVP	2-12
Figure 2-14	2-13
Figure 2-15	SVP with reversing relay installed	2-14
Figure 2-16	Reversing relay	2-14
Figure 2-17	Double-acting SVP with KZ03 air pressure regulator with filter.....	2-15
Figure 2-18	Double-acting SVP without air pressure regulator	2-16
Figure 2-19	Diaphragm actuator	2-18
Figure 2-20	Rotary actuator.....	2-18
Figure 2-21	Electrical wiring connection points	2-19
Figure 2-22	Electrical wiring for model AVP300/302/200/202.....	2-20
Figure 2-23	Electrical wiring for model AVP301/201 (4-conductor cable)	2-20
Figure 2-24	Electrical wiring for model AVP301/201 (2-conductor cable)	2-21
Figure 2-25	Wiring when the monitoring system is a voltage input device.....	2-21
Figure 2-26	Unlock positioner case.....	2-24
Figure 2-27	System configuration of intrinsically-safe SVP	2-26
Figure 2-28	Model AVP301/201 wiring resistance.....	2-27
Figure 2-29	Flameproof cable gland	2-28
Figure 2-30	Constituent elements of flameproof cable gland	2-28

List of Figures & Tables

Figure 2-31	Explosionproof elbow.....	2-28
Figure 2-32	SVP fitted with cable gland.....	2-29
Figure 2-33	SVP fitted with universal elbow.....	2-29
Figure 2-34	Arrangement of lock nut and O-ring.....	2-31
Figure 3-1	External zero-span adjustment switch.....	3-1
Figure 3-2	3-2
Figure 3-3	3-3
Figure 3-4	3-3
Figure 3-5	3-3
Figure 3-6	3-3
Figure 3-7	SFC ID Key.....	3-4
Figure 3-8	External switch turning (clockwise).....	3-8
Figure 3-9	External switch turning (counterclockwise).....	3-8
Figure 4-1	Electrical connection when the position transmission function is not used.....	4-4
Figure 4-2	Electrical connection when the position transmission function is used.....	4-5
Figure 4-3	Flow characteristics overview.....	4-21
Figure 4-4	4-23
Figure 4-5	4-24
Figure 4-6	Forced fully open and forced fully closed values.....	4-26
Figure 4-7	Valve fully closed position (zero) adjustment.....	4-32
Figure 4-8	Valve fully opened position (span) adjustment.....	4-34
Figure 4-9	Valve fully closed position (zero) adjustment.....	4-36
Figure 4-10	Valve fully opened position (span) adjustment.....	4-38
Figure 5-1	HART Communicator.....	5-1
Figure 5-2	HART communication structure.....	5-4
Figure 5-3	5-15
Figure 5-4	Forced fully open and forced fully closed values.....	5-15
Figure 6-1	Structure of the A/M Switch.....	6-1
Figure 6-2	EPM Balance Adjustment.....	6-5
Figure 6-3	SVP block diagram.....	6-9
Figure 6-4	SVP I/O flow.....	6-10
Figure 6-5	Replacement parts.....	6-11

<Tables>

Table 3-1:	Integral SVP setting.....	3-2
Table 3-2:	Remote SVP setting.....	3-3
Table 4-1:	SVP PID parameter table.....	4-16
Table 4-2:	Hysteresis parameter table.....	4-16
Table 5-1:	PID parameter table.....	5-12
Table 5-2:	Hysteresis Parameter table.....	5-13

Chapter 1: Introduction

1-1: SVP models

The SVP is an intelligent valve positioner that can be connected to a 4-20 mA controller output signal line. Since all adjustments can be performed electrically, the relationship between the input signal and the position of the control valve can be set arbitrarily. Split range and other special settings are also easy to set up.

There are two types of SVP, the integral type and the remote. For each type there are three models each having different communication functions.

Integral type

Model AVP300: Analog signal (4 to 20 mA DC) without travel transmission

Model AVP301: Analog signal (4 to 20 mA DC) with travel transmission

Model AVP302: HART communication protocol model

Remote type

Model AVP200: Analog signal (4 to 20 mA DC) without travel transmission

Model AVP201: Analog signal (4 to 20 mA DC) with travel transmission

Model AVP202: HART communication protocol model

An overview of an SVP3000 system is shown below.

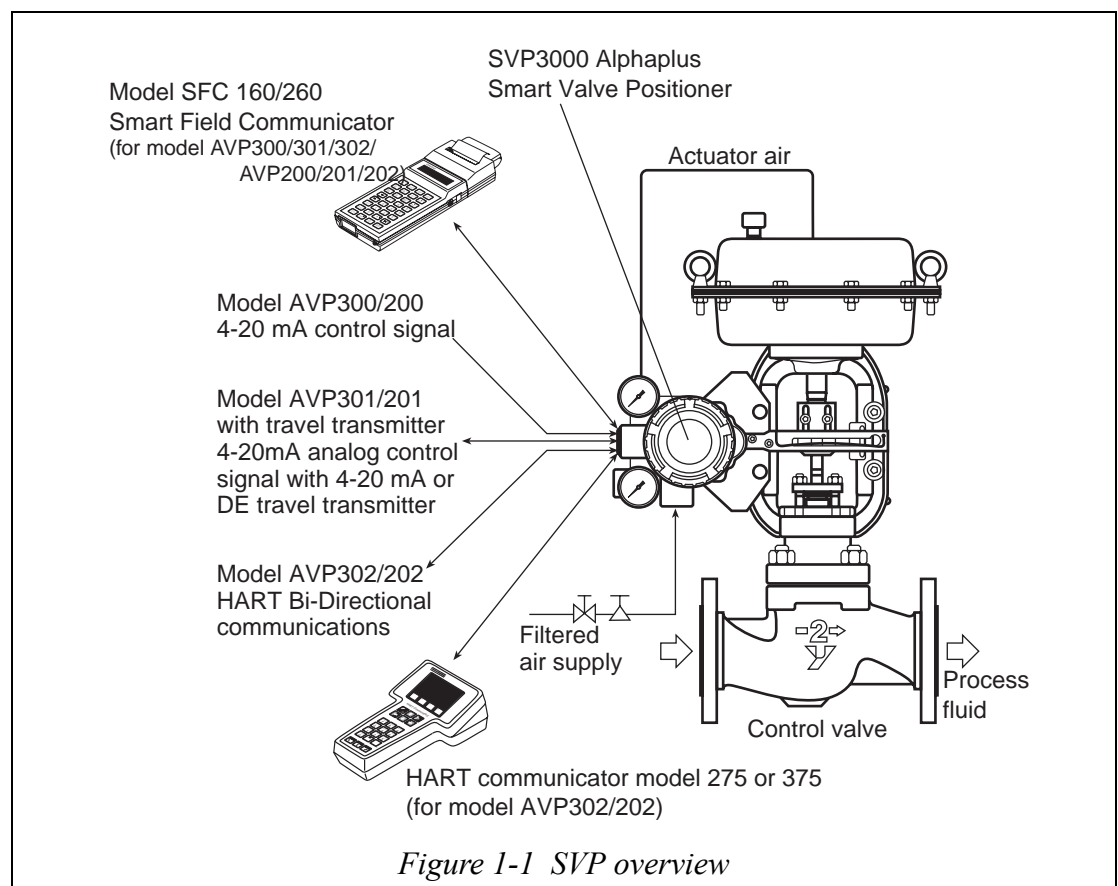

1-2: System structures

Without position transmission output (Models AVP300 and AVP200)

This figure shows the structure of a system in which the SVP position transmission function is not used.

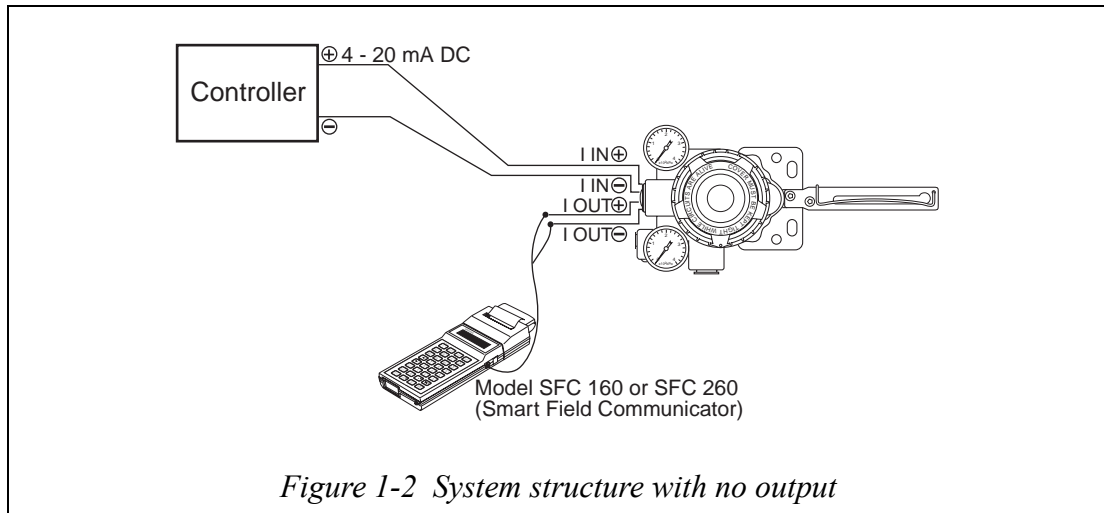

Figure 1-2 System structure with no output

Position transmission output (Models AVP301 and AVP201)

Analog output

This figure shows an example of the structure of a system in which the position is output as a 4-20 mA DC analog signal.

In this system, the analog signal from the SVP is directly output to the host monitoring system.

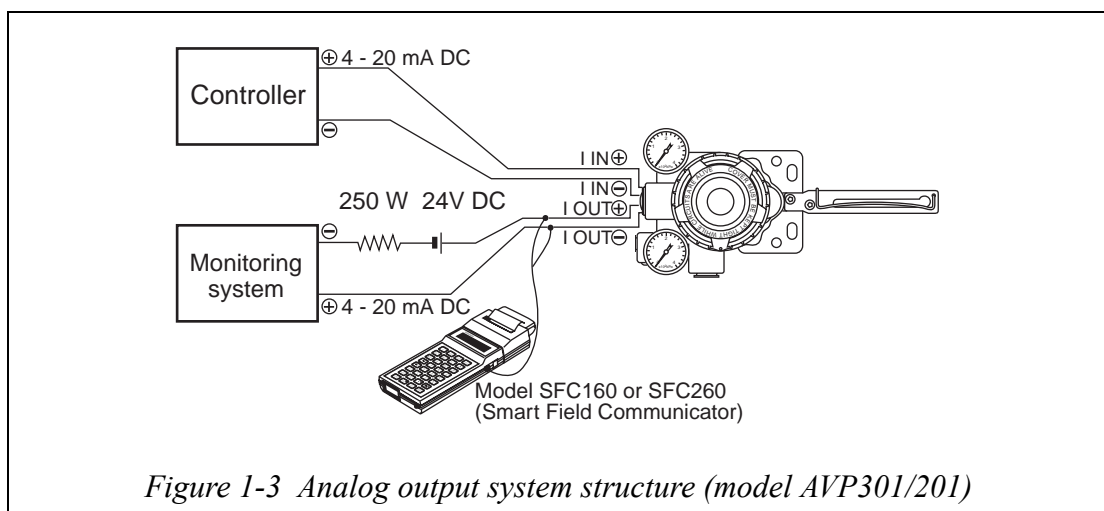
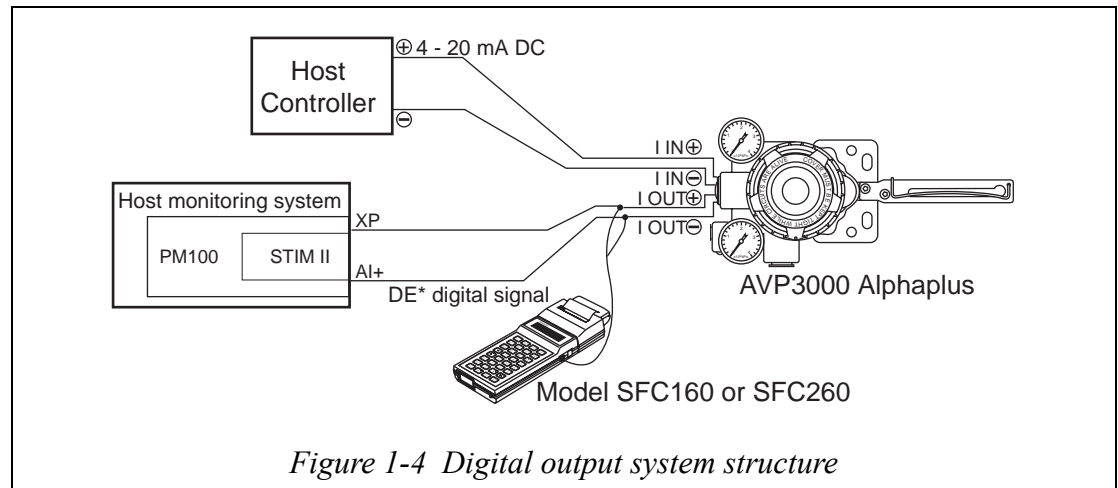

Figure 1-3 Analog output system structure (model AVP301/201)

DE protocol

This figure shows the structure of a system in which the position detected by the SVP, the values of the SVP settings, and the results of self diagnostics are output in the DE (Digital Enhancement) protocol*, which is a protocol for transmission of digital signals.

In this system structure, the digital signals in the DE protocol* transmitted from the SVP are output to a monitoring system that can directly input these signals.



STIM II (Smart Transmitter Interface Module)

- Interface module for digital signals in the DE protocol*.

PM100 (Process controller - R20 or later model)

- A process controller on the UCN. Simultaneously performs functions such as adjustment control, sequencing, calculation, and process I/O.

⚠ CAUTION

If the STIM II is used and the position transmission output signal from the SVP is output as a PV value, set the valve forcibly closed (SHUT OFF) value to -0.2% or higher so that the position signal STI point PV value is not taken to be BadPV.

* DE and DE protocol are registered trademark of Honeywell, Inc.

~Note *Switching the output format*

The output format provided by the SVP is specified by the user in the settings data specified when ordering the SVP. The SVP is set up at the factory for either analog output specifications or digital output specifications.

Note, however, that the output format can be switched freely by the user using the Smart Field Communicator (SFC).

HART communication (Models AVP302 and AVP202)

This figure shows the structure of a system in which the position detected by the SVP, the values of the SVP settings, and the results of self diagnostics are output in the HART communication protocol.

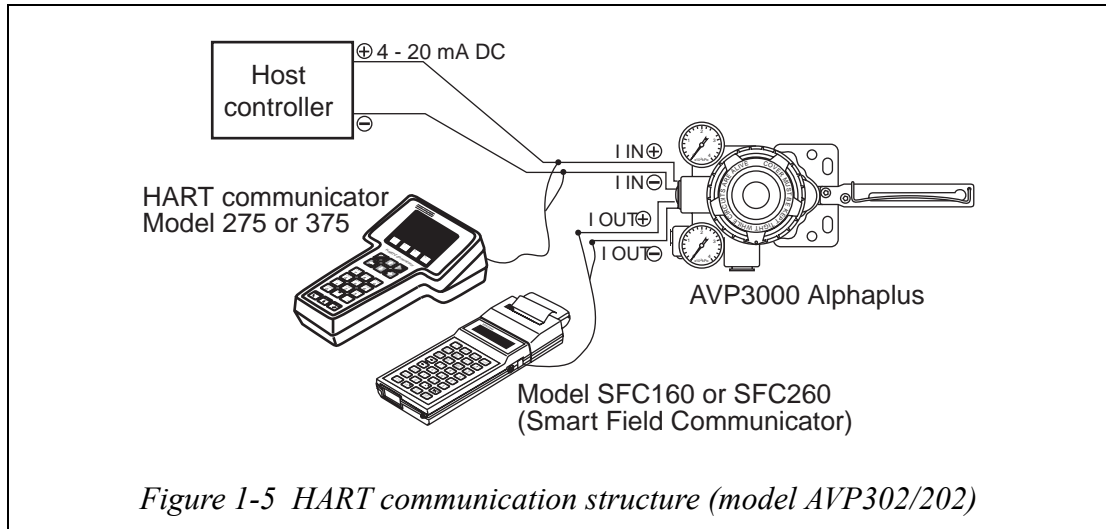

1-3: Communication

There are three ways to communicate with the SVP: manually, using a Smart Field Communicator (SFC) or using a HART communicator.

Manual communication

Initial SVP configuration is typically performed using a screwdriver. Auto-setup and travel calibration, which detect the characteristics of the valve, as well as zero/span adjustment can all be performed manually.

Without further configuration, the SVP provides valve travel from fully open to fully closed from a 4-20 mA analog signal (refer to ordered specifications) or analogous HART signal.

Using a Smart Field Communicator (SFC)

Yamatake model SFC160/260 Smart Field Communicators can be used for all configuration, calibration and maintenance of the SVP. SVP-specific communicator functions are documented fully in this manual. See the SFC Smart Field Communicator Manual to learn more about the SFC.

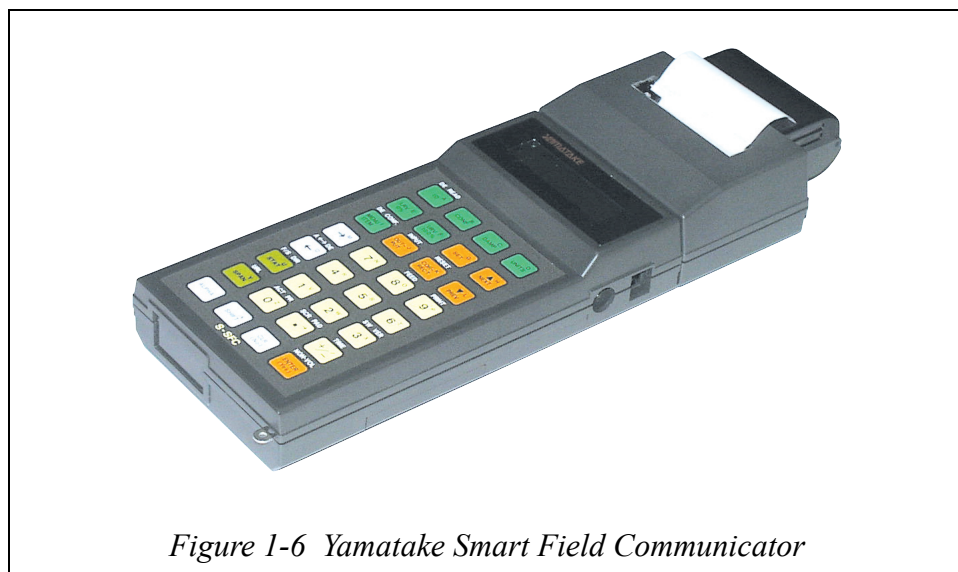

Figure 1-6 Yamatake Smart Field Communicator

Using a HART communicator

Emerson Electric HART communicator model 275 can be used for all configuration, calibration and maintenance of model AVP302/202 SVP-specific communicator functions are documented fully in this manual. See the HART communicator manual to learn more about the HART communicator.

1-4: Structures and functions of SVP

Main components

The main SVP components are shown below.

Integral type (model AVP300/301/302)

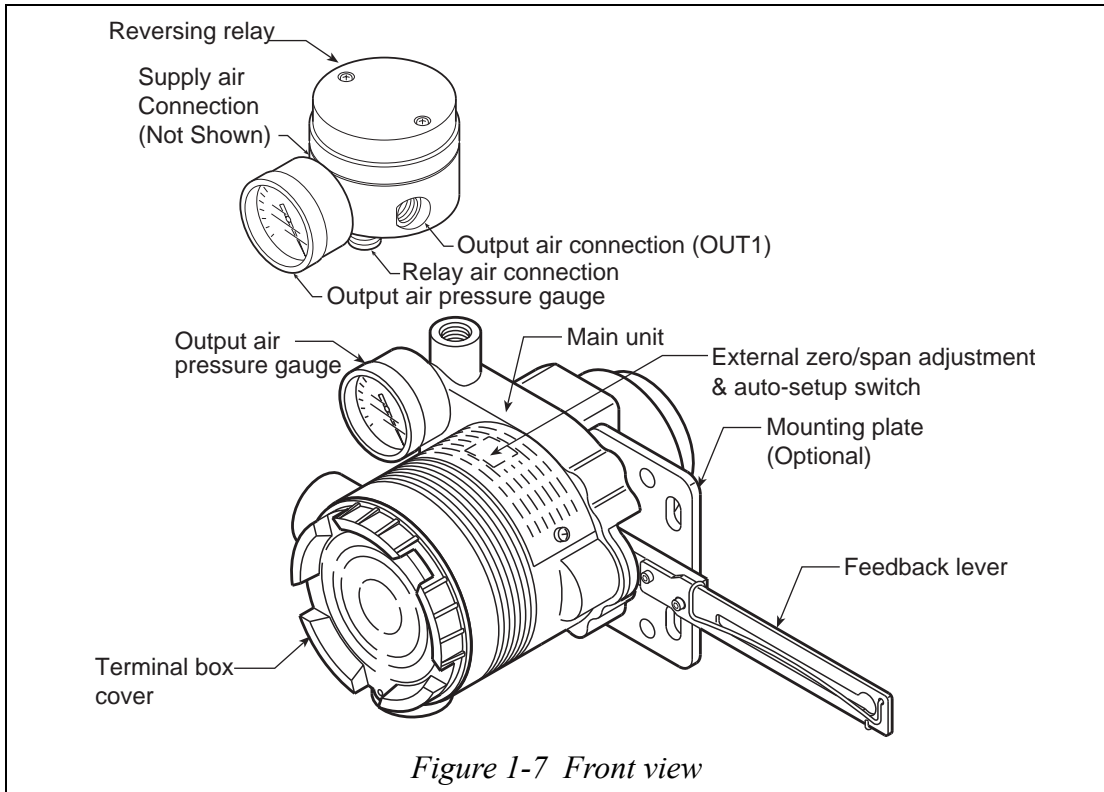

Figure 1-7 Front view

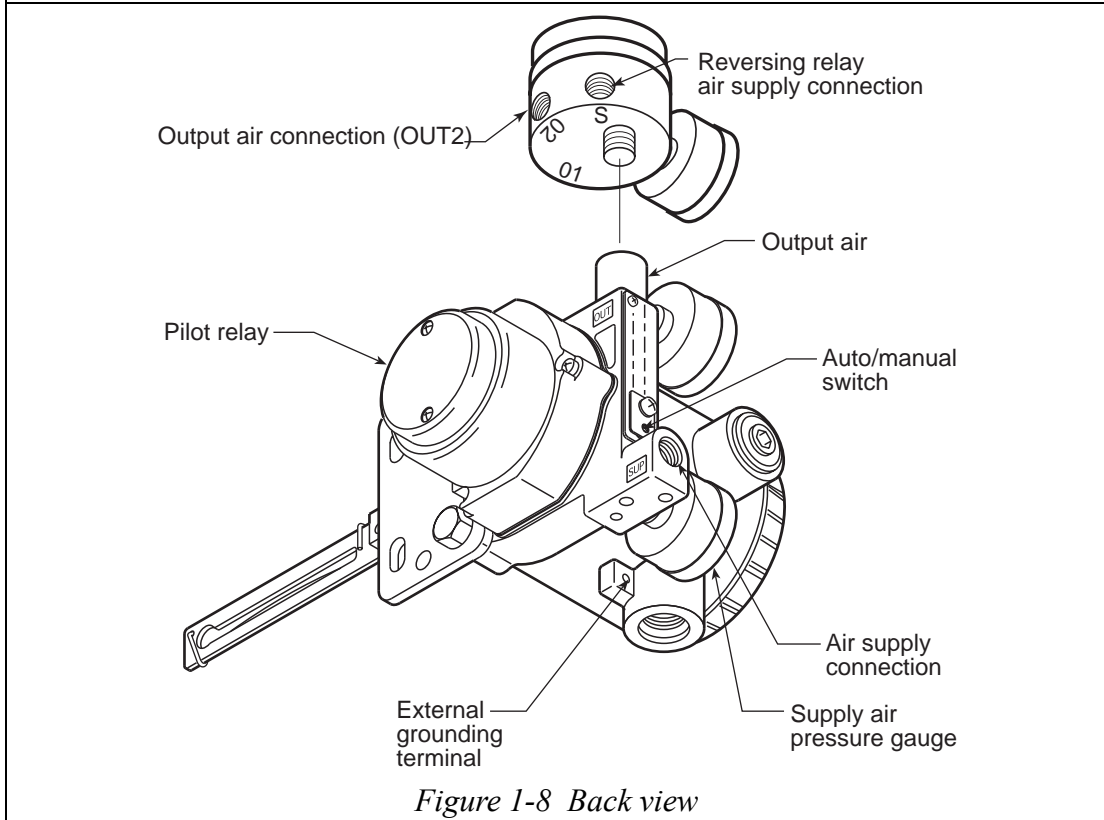
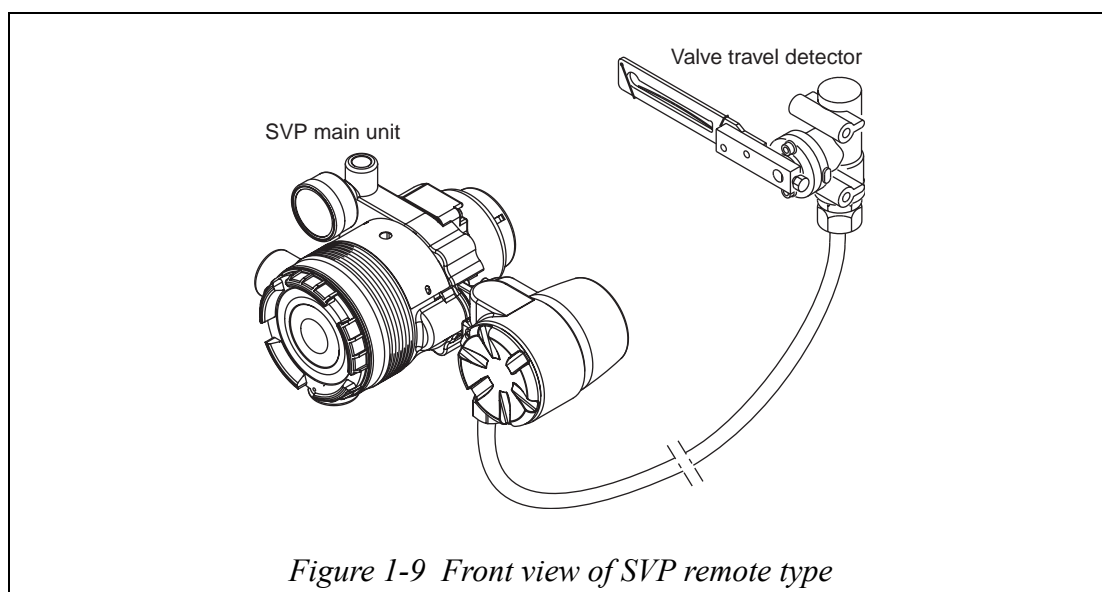

Figure 1-8 Back view

Remote type (model AVP200/201/202)



Names parts and functions of main components

Part	Description
Main unit	Holds the electronics module, EPM (electro-pneumatic converter module), and VTD (position sensor).
Pilot relay	Amplifies the pneumatic signal from the EPM (electro-pneumatic converter module) and converts it to a pneumatic signal for the actuator.
Feedback lever	Acquires the motion of the control valve lift and transmits it to the VTD (position sensor).
Auto/Manual switch	Switches the control method for the pneumatic output between the automatic operation state and the manual operation state. See “6-1: Auto/Manual selection switch” on page 6-1. for information on operating procedures.
External zero/span adjustments Auto-setup switch	Allows the zero and span to be adjusted and auto setup to be performed with just a flat-bladed screwdriver without using the SFC.
Supply air pressure gauge	Indicates the supplied air pressure.
Output air pressure gauge	Indicates the pressure of the output air.
Air supply connection	The air supply is connected to this connector. Labeled “SUP”.
Output air connection	The output air is sent to the actuator from this connector. Labeled “OUT”.

Part	Description
Mounting plate (option)	<p>Used to mount the actuator on the SVP itself.</p> <p>The shape of this part will differ depending on the specifications (the type of actuator).</p>
Reversing relay	<p>Used when a double-acting actuator is used.</p> <p>The reversing relay is added at the output air connector of the SVP. The reversing relay provides two outputs: output air pressure 1 (OUT1), which is the SVP output air pressure without modification, and output air pressure 2 (OUT2), which is the SVP output air pressure with air pressure supplied to the reversing relay (SUP) subtracted from OUT1. Connecting these outputs to the two cylinder chambers of the double-acting cylinder allows that cylinder to function as a double-acting positioner.</p>
Output air connection (OUT1)	<p>The air output from this connector is delivered to the actuator.</p> <p>O1 is written on the lower section of the reversing relay.</p>
Output air connection (OUT2)	<p>The air output from this connector is delivered to the actuator.</p> <p>O2 is written on the lower section of the reversing relay.</p>
Feedback cable	<p>Connect the VTD and the main unit of SVP.</p>
Valve travel detector	<p>Senses a valve position through the feedback lever.</p>

Terminal box

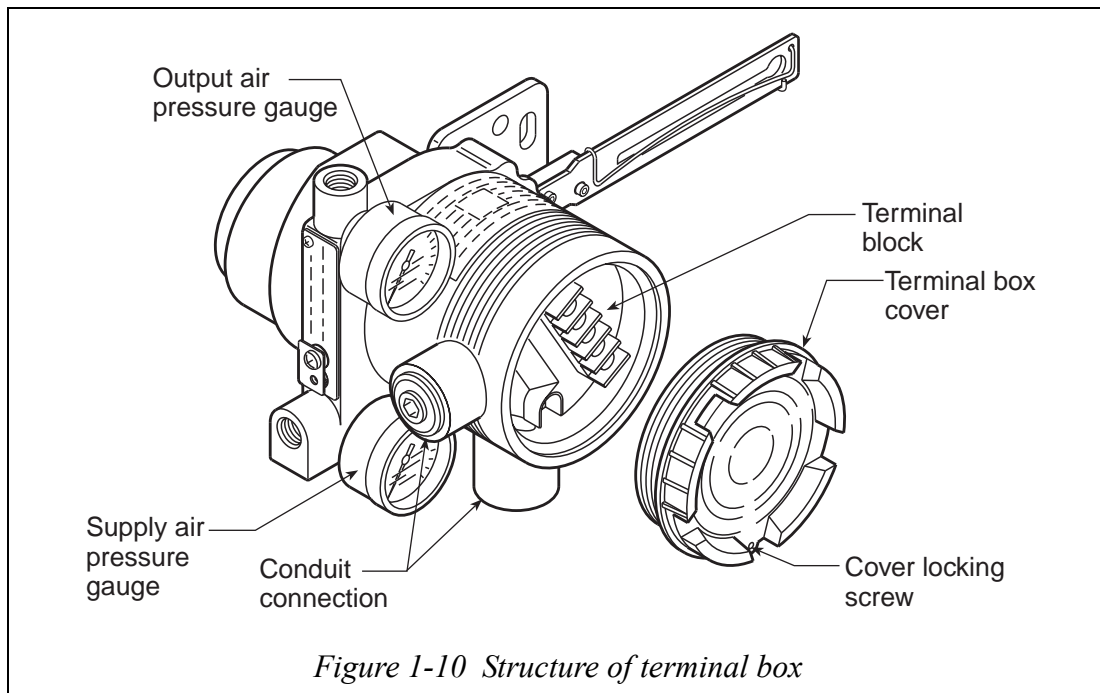

Figure 1-10 Structure of terminal box

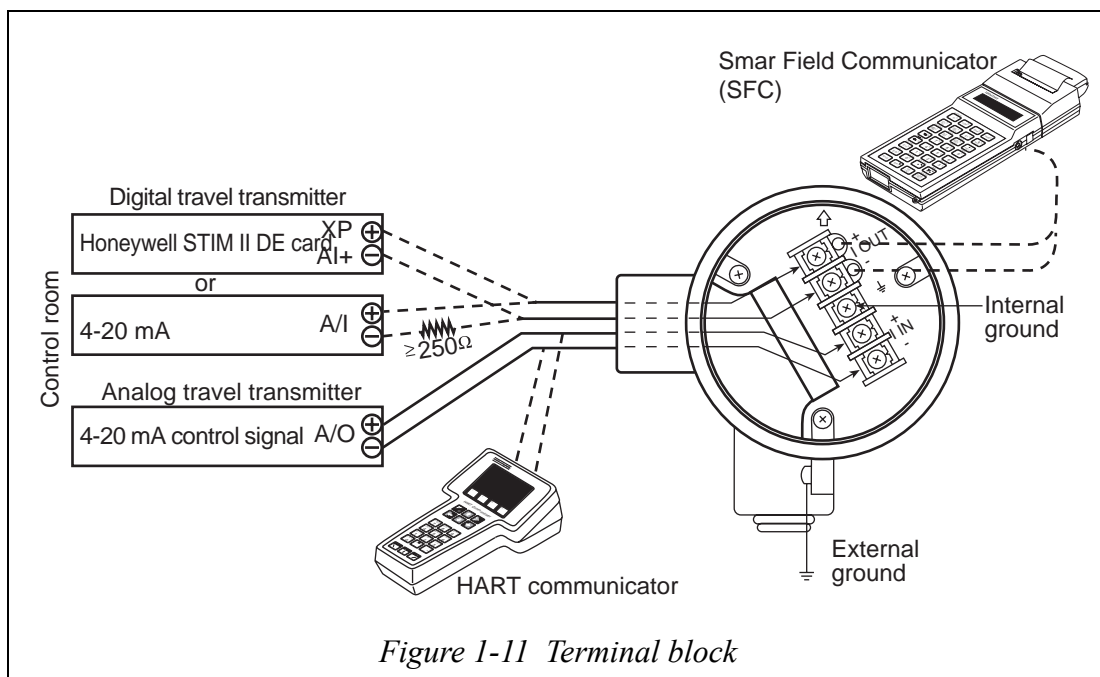

Figure 1-11 Terminal block

Names of parts and functions of terminal box

Part	Description
Terminal box cover	The cover features a pressure-resistant explosionproof structure.
Cover locking screw	Must be tightened down when an explosionproof model SVP is used in a hazardous area.
Terminal of input signal	Labeled "I IN". Connect the signal cable from the host controller.
Terminal of output signal	Marked "I OUT". Connect the position transmission signal cable. This terminal screw is not present in the model AVP300/200, which do not have a position transmission function.
External grounding	Ground this pin as stipulated in the specifications.
Internal grounding	When using the SVP, use either the internal or the external ground terminal, but be sure not to create a 2-point ground.
Conduit connection (1)	Port for connection cables. The stipulated pressure-resistant packing type cable adaptor (available as an option) must be used if an explosionproof model SVP is used in a hazardous area.
Conduit connection (2)	Port for connection cables. The stipulated pressure-resistant packing cable adaptor (available as an option) must be used if an explosionproof model SVP is used in a hazardous area. This port is normal sealed with a blind plug.
Pin for SFC	The SVP can communicate with an SFC if the SFC communication cable hooks are connected to these pins.

Chapter 2: Installation

2-1: Site Selection

The SVP is designed to withstand severe operating conditions. It is designed to operate:

- Ambient temperature range conforming to the requirements for explosion-protection (See “ Explosion-protected models” on page ii.).
- In relative humidity of 10 to 90%
- Ambient temperature change rate is not more than $\pm 20^{\circ}\text{C/hr}$.
- Where magnetic field induction is not more than 400 A/m (Avoid locations near large-scale transformers, high-frequency furnaces, and similar equipment.)
- Don't use the transceiver near the SVP in order to operate normally.
- Vibration under 20 m/s^2 (5 to 400 Hz) (model AVP300/301/302 and AVP200/201/202 main unit)
- Vibration under 100 m/s^2 (5 to 2000 Hz) (model AVP200/201/202 position detection unit)

~Note *The vibration conditions for this equipment is stipulated for the vibration at the positioner.*

2-2: Installing SVP

Yamatake Smart Valve Positioners are designed for use in combination with a control valve that uses a direct- or reverse-acting or rotary actuator. The main SVP unit weighs about 2.5 kg. It should be attached in the same way you would attach a conventional current-pneumatic positioner.

CAUTION

- Do not install the SVP near a large transformer, high-frequency furnace, or other equipment that generates a magnetic field. Unexpected operation can result.
- Incorrect settings can reduce the SVP's effectiveness and cause damage to or failure of the SVP.
- When installing a control valve, provide adequate clearance around the valve for maintenance (piping, wiring, and adjustment), and verify that the valve is oriented correctly.
- Transport the SVP in its original packing to as close to the point of installation as possible.
- Do not apply excessive force to the feedback lever or bend the feedback pin when installing the valve.
- Be sure to tighten bolts and nuts securely on the SVP and control valve.

 WARNING	
<ul style="list-style-type: none"> • To avoid physical injury, use caution when attaching the SVP: • Be aware of sharp edges, such as the threaded edges of the terminal box cover and any sharp edges on the unit. • The type and size of the actuator and the SVP settings determine the type of mounting plate to be used. If you ordered your SVP with the actuator type specified, then the SVP should come with the proper mounting kit, and the correct actuator settings should already be programmed into the SVP. The Auto-Setup program is then used to calibrate the SVP. 	

Procedure

step	Procedure
1	The SVP comes with an actuator mounting kit appropriate to your control valve and actuator. Fasten the mounting plate to the SVP securely, using the two hexagon head bolts and spring washers provided.
2	Fasten the SVP (mounting plate) securely to the actuator's mounting structure using the bolts and washers provided. During this operation, pass the actuator's feedback pin through the slot in the SVP feedback lever.
3	For the SVP remote type (model AVP200/201/202), refer to “2-3: Installing a remote type SVP (Model AVP200/201/202)” on page 2-7.

~Note *For the installation of the actuators, refer to the assembly diagram inside the package.*

Examples

With HA1 actuator

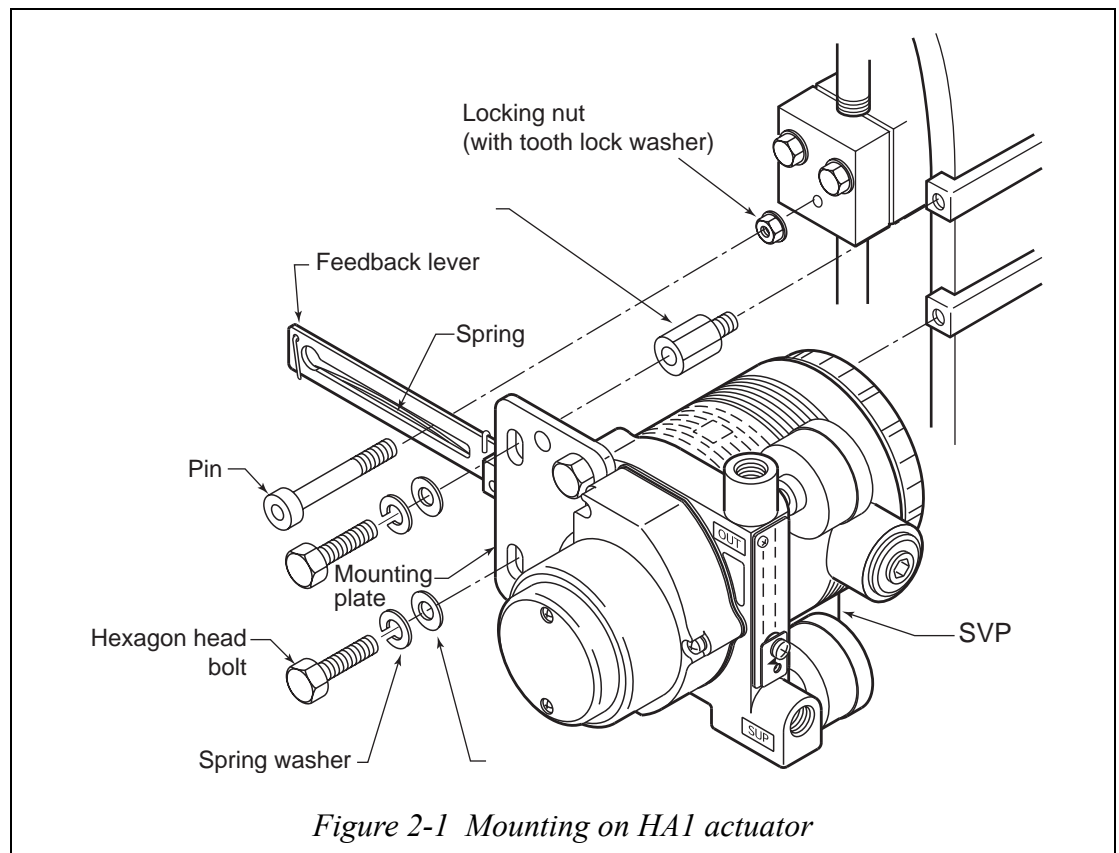

With HA2~4, PSA1~4, 6, VA1~6 actuators

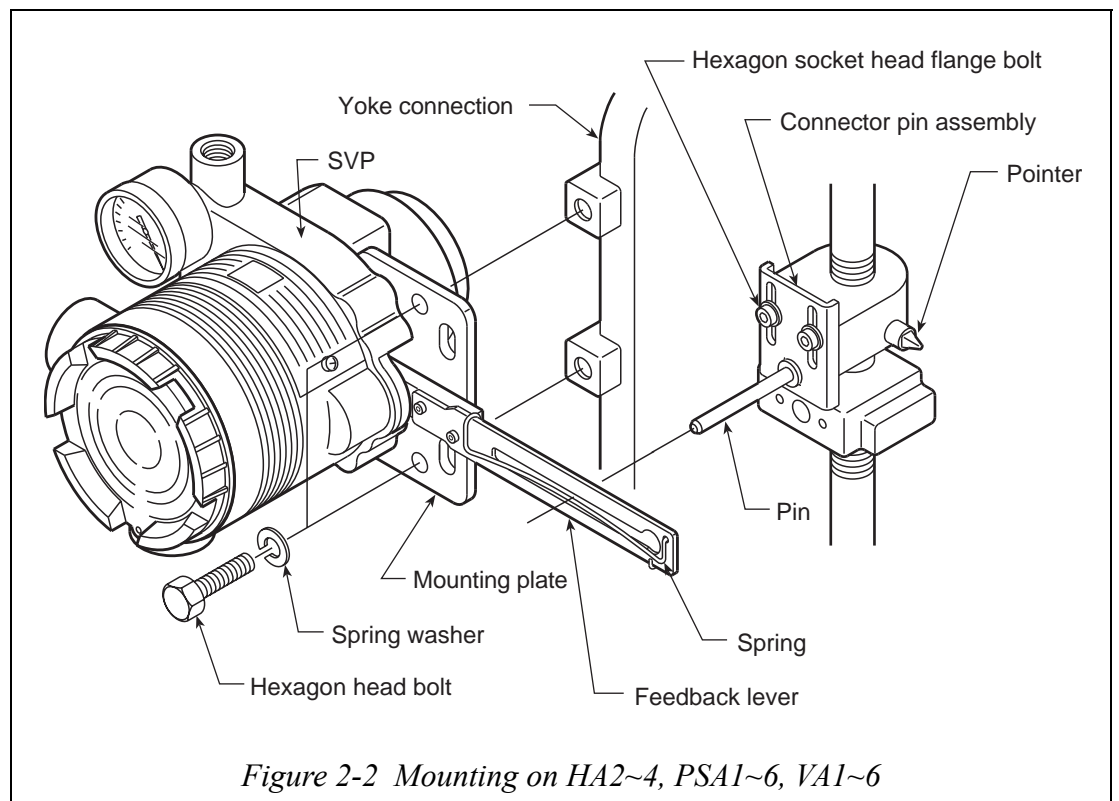

Connecting the feedback pin and the feedback lever

The following points must be observed when connecting the SVP feedback lever and the feedback pin on the actuator. These parts must be connected correctly.

- (1) Only a 6 mm diameter pin may be used.
- (2) The pin must be caught between the guide and the spring.

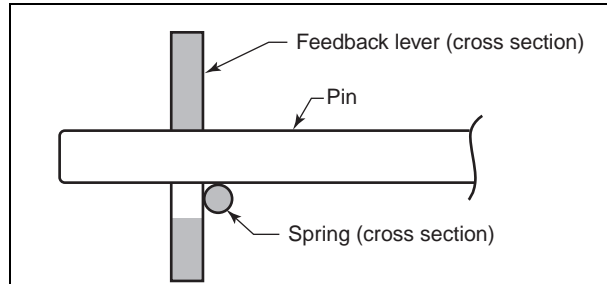

Figure 2-3 Feedback pin and feedback lever connection

- (3) The angle between the feedback lever and the pin must be 90° when seen from above

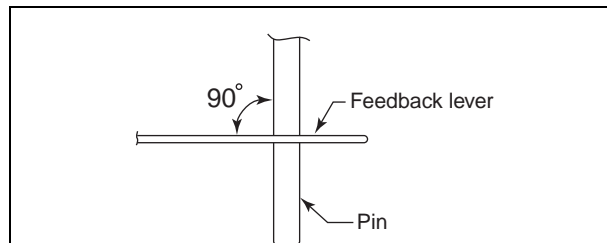

Figure 2-4 Angle between feedback lever and pin

- (4) Assemble the feedback lever and the SVP using the two hex socket bolts provided. The feedback lever rotates up to 20° from the horizontal (40° travel). If this limit is exceeded, then the SVP will not operate properly.

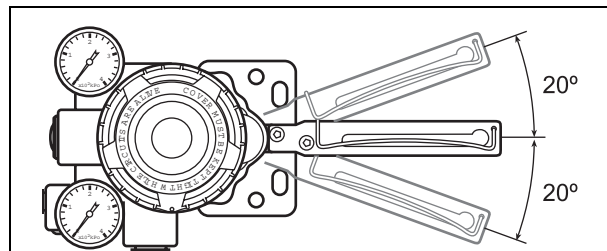

Figure 2-5 Feedback lever maximum range of motion

- (5) For large actuators, use the included feedback lever extension

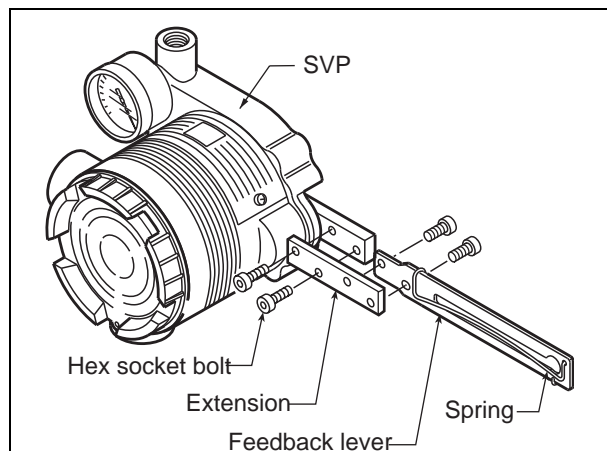

Figure 2-6 Attach the feedback lever (with extension)

Space allowance for maintenance

The SVP has a nozzle flapper structure at the rear of the main unit. The SVP is designed so that the nozzle flapper structure can be accessed by removing the pilot relay cover at the back of the main unit when cleaning the flapper and adjusting the EPM balance. (See “6-4: EPM (Electro-pneumatic Converter Module) balance adjustment” on page 6-4.)

When designing mounting bracket, consider the adequate clearance to remove the pilot relay cover for maintenance.

Connecting the air supply

Clean and dry supply air ensures long-term stability of the SVP.

The air supply must be clean; it should not contain foreign substances (moisture, oil, or dust). The air must be dry, with a dew point at least 10°C {18°F} lower than the SVP's lowest site operating temperature. For example, if the lowest environmental temperature the SVP is exposed to is 0°C {32°F}, then supply air should not condense at temperatures under -10°C {14°F}.

Pressure regulator with 3µm or better filter must be installed between the air supply and the SVP as close as possible to the SVP unit. The pressure regulator with filter.

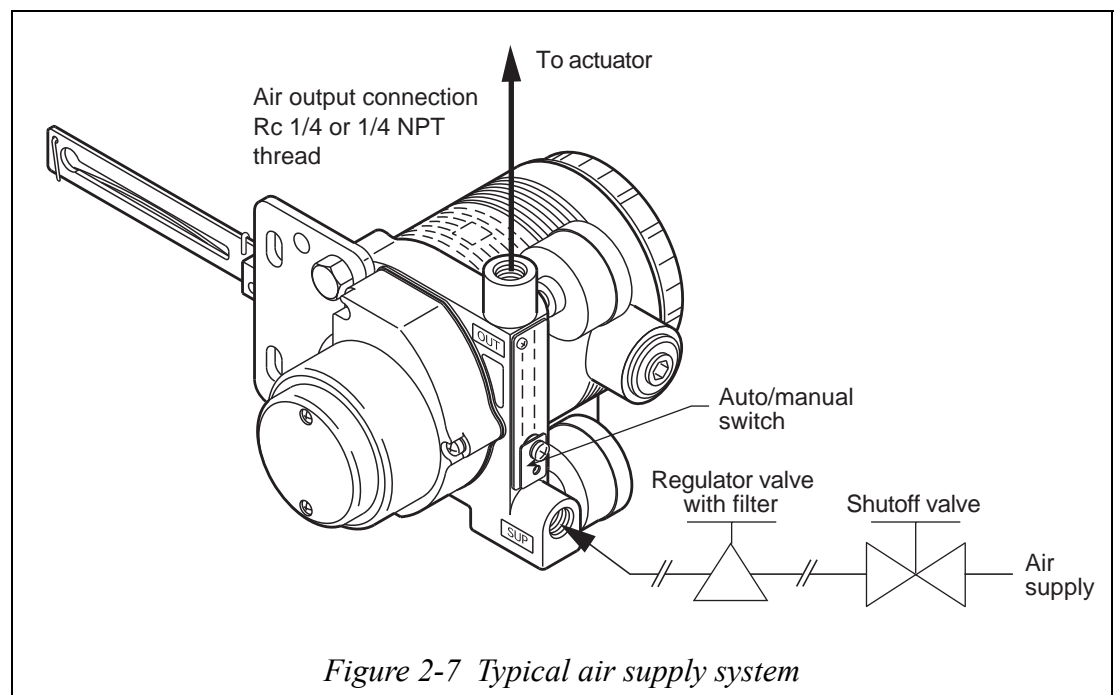

Pressure regulator with filter

- The control valve can be operated manually by using this regulator in conjunction with the Auto/Manual switching function.
- Use a 3 µm or better filter to solid-state particulate matter from the air supply.
- If a filter is not provided on the regulator, insert a separate 3 µm or better filter immediately before the regulator.

Shutoff valve

- This valve is used to temporarily shut off air supply to the SVP.
- The shutoff valve enables disconnection of the SVP from the control valve for ease of maintenance.

Recommended piping practices

- Air supply pipes should have an inside diameter of 6mm {1/4 inch} (8mm {3/8 inch} outside diameter tubing recommended).
- Pipes should match the installation environment, i.e. for a corrosive environment, use vinyl-covered copper pipes.
- Use joints that precisely fit the pipes.
- Sealing tape is preferable to solid or liquid sealants for pipe joints to SVP air connections. Prevent sealing tape/sealant from entering pipes.
- Use the right length of piping; avoid excess lengths.
- Completely flash pipes before use, checking for burrs and other problems.
- Check for leaks after installation.

~Note *Instead of air supply connection of SVP, install it during the air output connection and actuator when connect solenoid valve or air valve for emergency shut down.*

2-3: Installing a remote type SVP (Model AVP200/201/202)

Refer to “2-2: Installing SVP” on page 2-1.

Disconnecting the positioner body and remote cable

Step	Procedure
1	Open the cover of terminal box for remote cable assembly.
2	Take off five terminals connected to a remote cable.
3	Unscrew the cable grand or flameproof cable grand from the case.
4	Pull out a cable from conduit of terminal box so that a remote cable is not damaged.

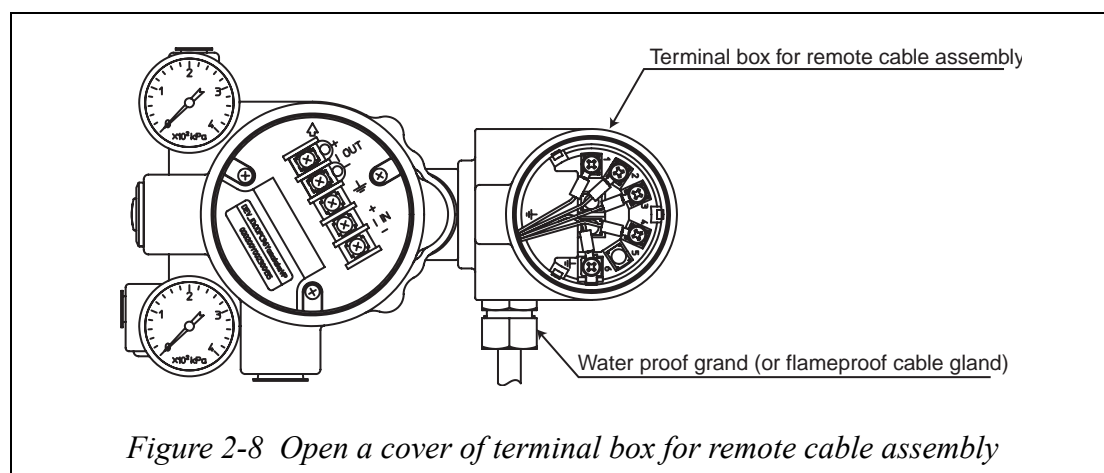

Connecting the positioner body and remote cable

Step	Procedure
1	Insert a remote cable in a cable grand or flameproof cable grand.
2	Insert a remote cable in conduit of terminal box.
3	Connect a remote cable and terminal with M4 screw closely not to mistake a combination of number for a color as there is it on the cover back side of terminal box.
4	Screw the cable grand or flameproof cable grand tightly into the conduit of terminal box. (If an rigid metal conduit is to be attached, remove the waterproof cable grand before attaching the conduit. However In case of flameproof specification, don't remove the flameproof cable grand because there is G1/2 female screw at resist flameproof cable grand.)
5	Close a cover of terminal box. (In case of flameproof specification, close lock screw.)

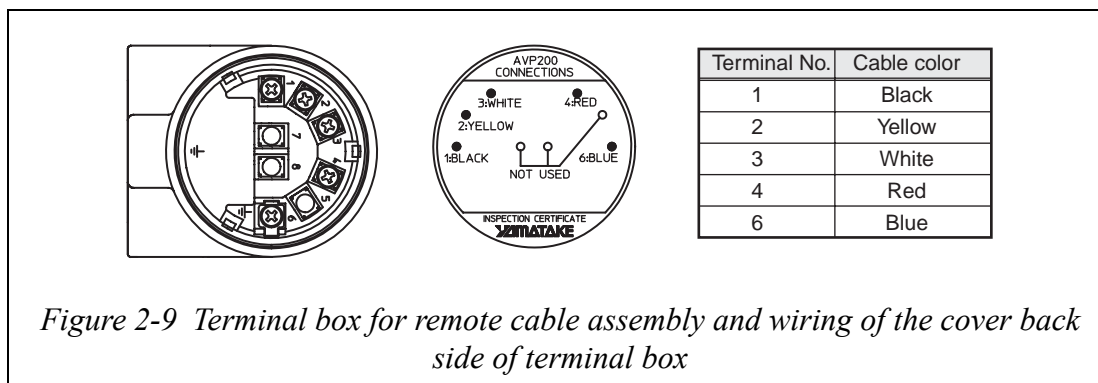

Length adjustment of remote cable

Step	Procedure
1	Cut a remote cable in appropriate length after having removed a remote cable from terminal box.
2	Strip off about 6cm cable crusts of remote cable point part and strip off about 5mm coating of an electric wire.
3	Insert drain wire in the heat shrinkage tube and add an appropriate heat to the heat shrinkage tube and let you shrink.(When you do not have the heat shrinkage tube, please do the treatment that drain wire seems to insulate with another wire.)
4	Treat the solderless terminal (RAV1.25-M4 solderless round terminal) of a remote cable using appropriate solderless tool to each electric wire and drain wire.
5	Connect the positioner body and remote cable.

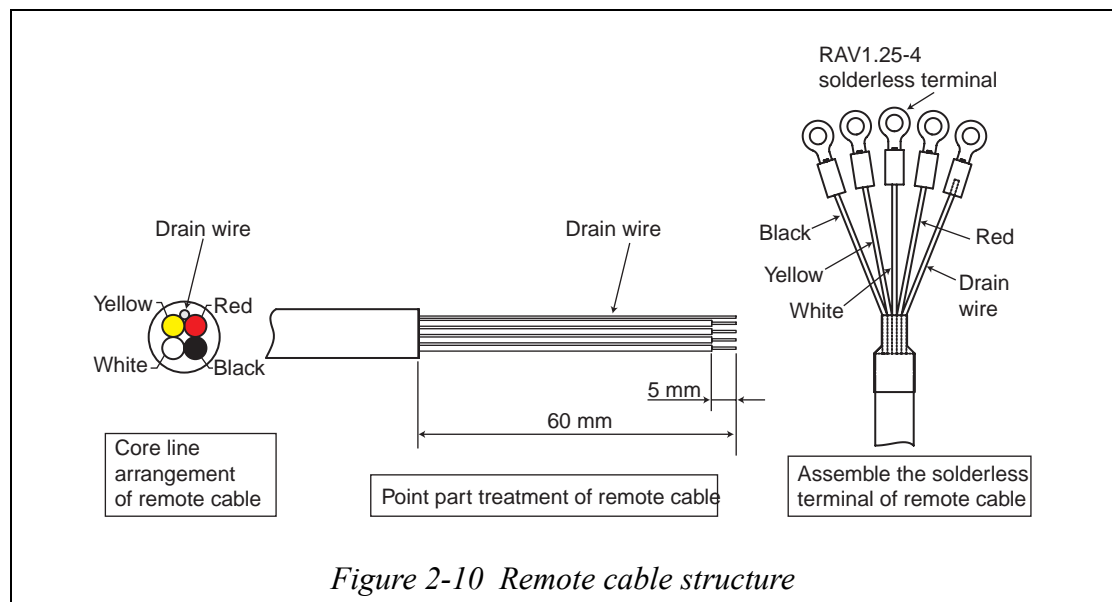

⚠ CAUTION

- While connecting and disconnecting any wiring and disassembly of the travel detector, make sure that no water or foreign objects enter the travel detector assembly or SVP conduits as this may adversely affect operation.
- Periodically tighten the waterproof gland and pressure-resistant packing type cable adaptor. Failure to do so may allow rainwater to enter the equipment and cause malfunctions.
- The cable cannot be removed from the position detector unit. However, the waterproof gland or pressure-resistant packing type cable adaptor can be removed.

Connecting the SVP and feedback cable

- (1) Insert the connector plug into the receptacle.
- (2) Gently push the connector assembly into the housing.

Screw the cable connector into the housing tightly so that the waterproof gland will keep water out. If you cannot screw it tight, unscrew it and move the connector assembly around inside so that it does not obstruct tightening of the cable connector.

After connecting the connectors, push the connector into the positioner. To insure that the stipulated water resistance is maintained, push the cable adequately far into the position detector and correctly assemble either a waterproof gland or cable gland at the entry point.

If an electrical cable conduit is to be attached, remove the waterproof gland before attaching the conduit.

(If the product is purchased preassembled with a Yamatake actuator, the cable on the positioner unit is already removed. There will be a blind plug attached to the positioner unit connection screw. Remove the blind plug and then attach the cable.)

Changing the feedback lever direction

Before attaching the valve travel detector to an actuator, you can change the mounting direction of the feedback lever.

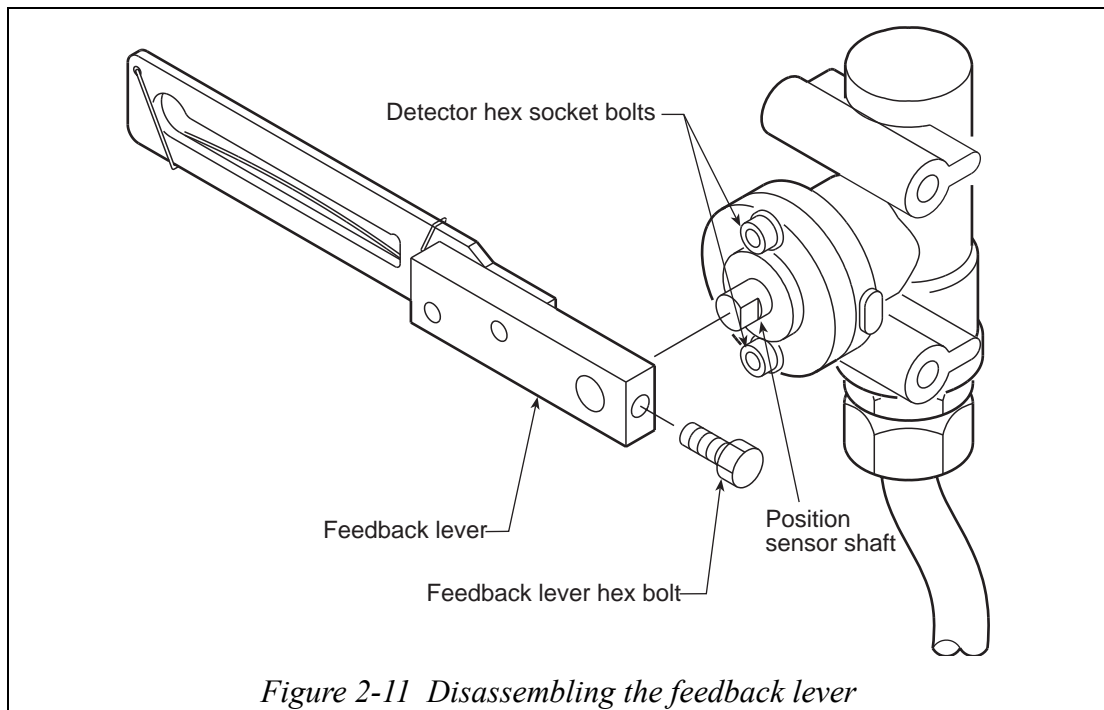

- (1) Loosen the feedback lever hex bolt until the Feedback lever can be removed.
- (2) Remove the feedback lever.
- (3) Rotate the position sensor shaft 180°.
- (4) Reattach the feedback lever to the position sensor shaft and tighten the feedback lever hex bolt, making sure that the tip of the Feedback lever hex bolt is touching the flat side of the position sensor shaft at a right angle.

~Note Do not loosen the two hex socket bolts that fasten the position sensor to the valve travel detector housing.

Attaching the valve travel detector to an actuator

- (1) Attach the valve travel detector to the actuator.
- (2) Set the valve at 50% opening either with an air pressure regulator or by using the valve's handwheel.
- (3) Adjust the position of the feedback pin and valve travel detector so that the center of the valve travel detector and the feedback lever form a right angle (refer to "Connecting the feedback pin and the feedback lever" on page 2-6).
- (4) Fasten the valve travel detector to the mounting plate with the included hex bolt and washer.

~Note *Do not point the cable removal port upwards*

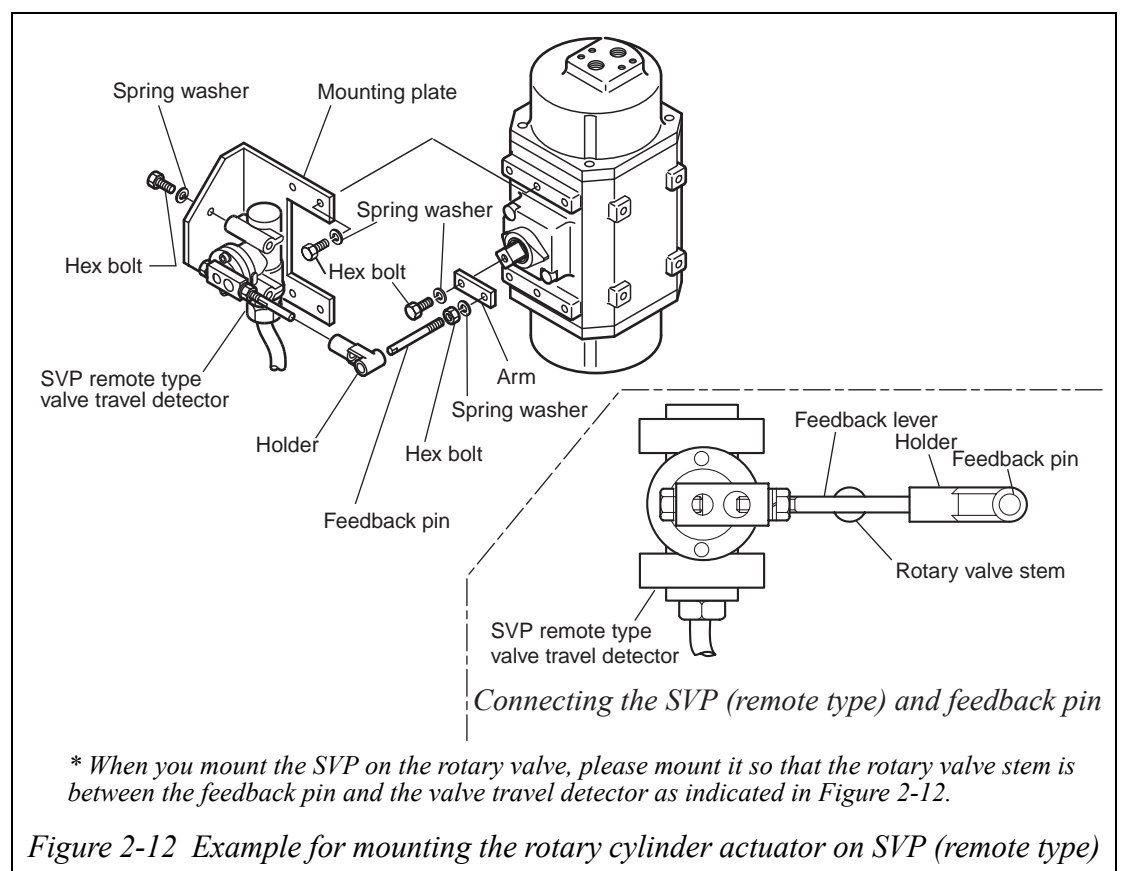

Installing the SVP main unit

Fasten the SVP to a 2-inch pole where it will be free of vibration in excess of 2 G (400 Hz).

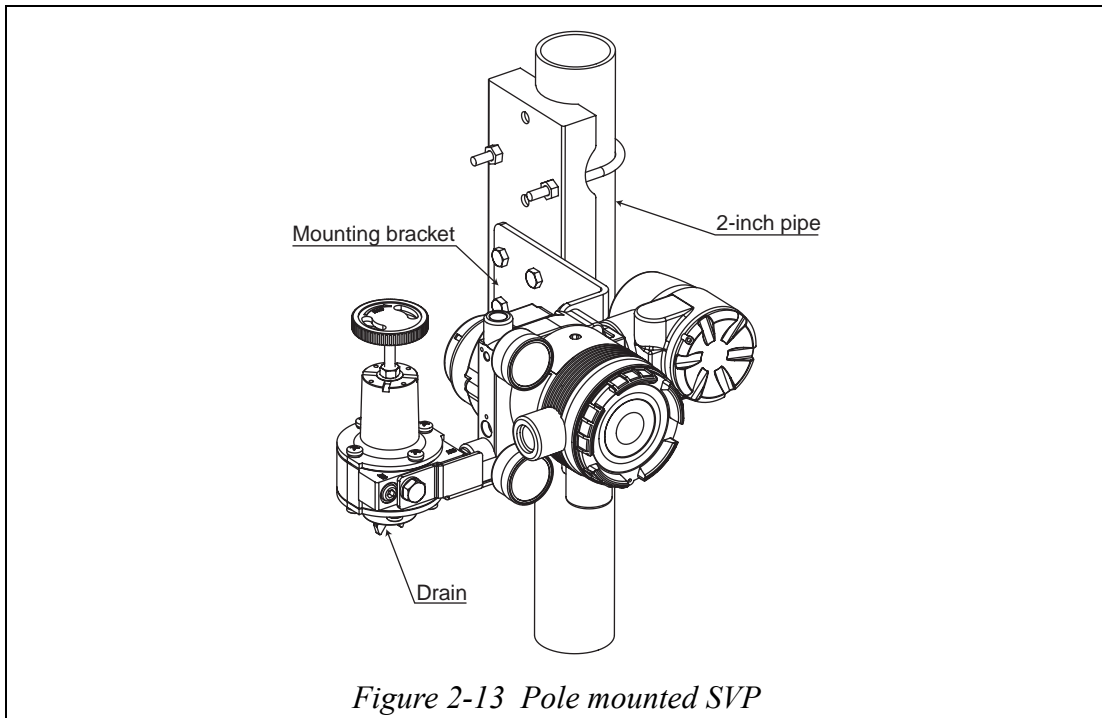

Figure 2-13 Pole mounted SVP

⚠ CAUTION

When attaching an air pressure regulator to the SVP, make sure the regulator air vent is facing down to prevent the entry of rain.

Note for cable wiring between travel detector and SVP main unit

When connecting the cable between the valve travel detector and SVP, consider the full operation area needed for the valve and the maximum safety of the remote SVP and personnel.

- Avoid a situation where the valve travel detector or SVP weighs directly on the cable. If this cannot be avoided, take steps such as attaching the cable to a column support.
- When you pull the cable upward, do not pull it directly upward. First pull downward then pull it up.
- You must follow the electrical device's technical standards for the cable construction.
- The length of cable between the remote-type SVP's valve travel detector and the positioner body can be cut to any length and then adjusted.
- Adjustment of the length of the cable requires the use of Yamatake's proprietary tool and must be carried out by an experienced Yamatake service person. Be sure to contact Yamatake before adjusting the cable length.

2-4: Installing a double-acting SVP for springless actuators

When an SVP is installed on a valve with a springless (double-acting) actuator, air pressure is needed on both the bottom and top of the actuator diaphragm to provide valve opening and closing proportional to a control signal. A reversing relay is used for this purpose.

Reversing relay

For the output air pressure of a reversing relay, P_{OUT2} is outputted.

$$OUT2 = P_{SUP} - OUT1$$

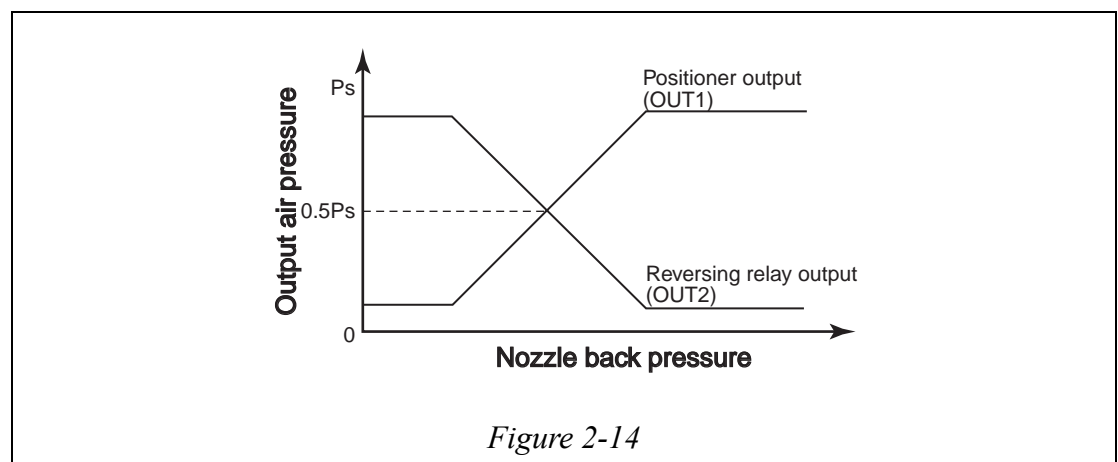

Installing the relay

- (1) Remote the dust plug from the output air connection.
- (2) Screw the relay air connection of the reversing relay into the output air connection on top of the SVP.

~Note *Sealing tape is preferable to solid or liquid sealants for pipe joints to SVP air connections. Prevent sealing tape/sealant from entering pipes.*

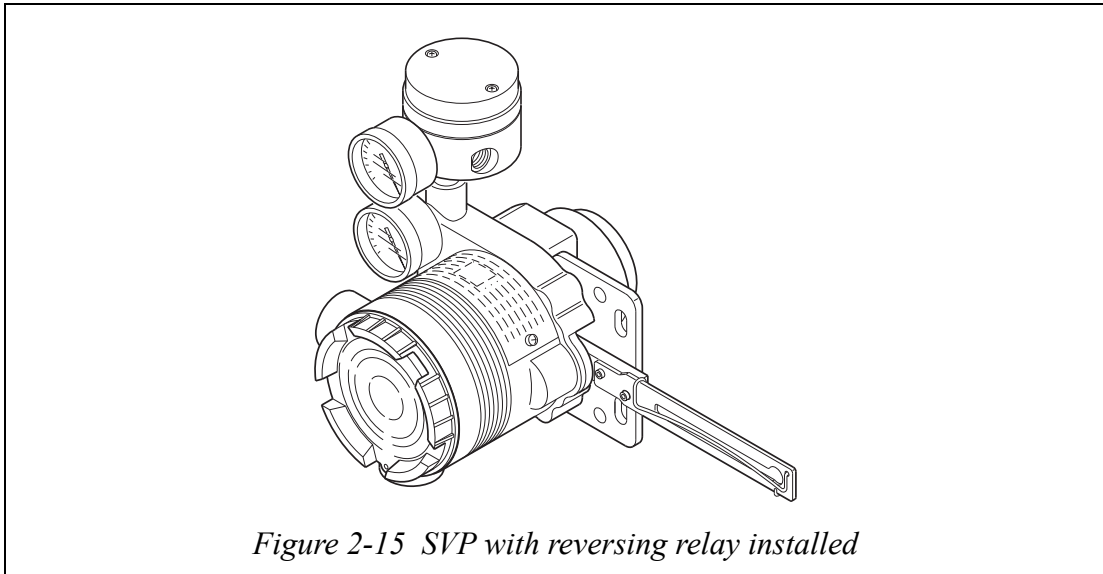

Figure 2-15 SVP with reversing relay installed

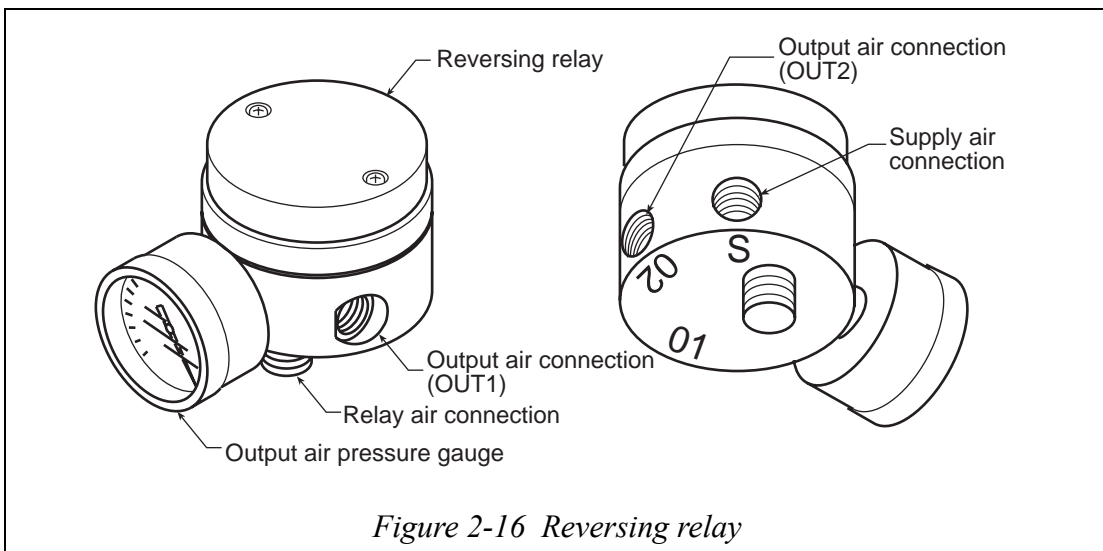

Figure 2-16 Reversing relay

~Note Make sure that the air piping connections and air pressure ranges as inscribed on the bottom of the reversing relay match your SVP.

The reversing relay has two output air connections:

- Output air connection 1 (OUT1) which passes through the SVP's output air pressure
- Output air connection 2 (OUT2) with the balance of the supply pressure (minus SVP output air)

Installing a double-acting SVP with a KZ03 air pressure regulator with filter

A KZ03 air pressure regulator with filter has two output air connections. Connect one of the output air connections to the supply air connection on the SVP. Connect the other output air connection on the KZ03 to the supply air connection on the reversing relay using sealing tape.

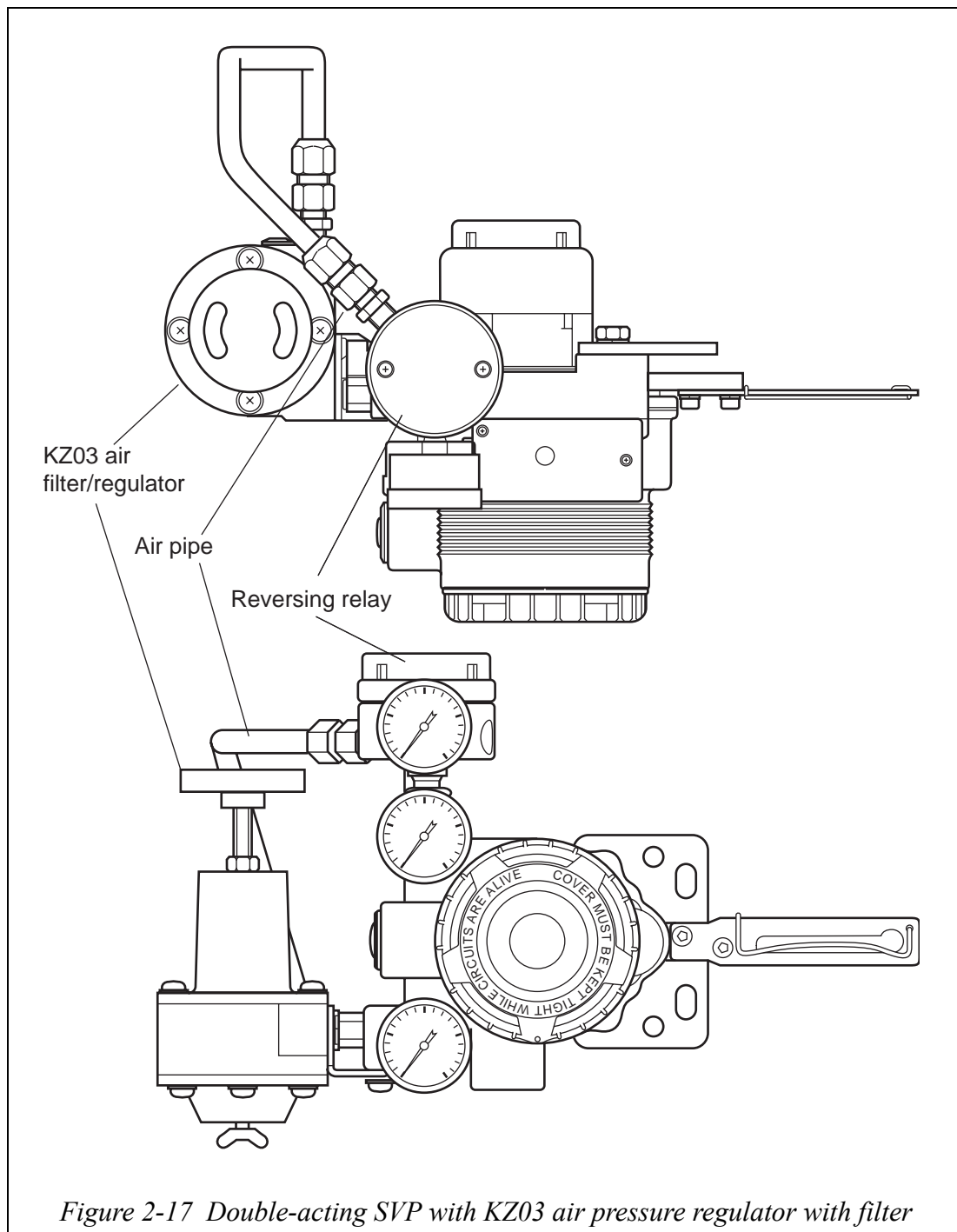

Figure 2-17 Double-acting SVP with KZ03 air pressure regulator with filter

Installing a double-acting SVP without an air pressure regulator

Using a T-connector, connect the air supply from the regulator and filter to both the SVP supply air connection and the supply air connection on the reversing relay using sealing tape. Make sure to connect only one regulator to an SVP and reversing relay combination.

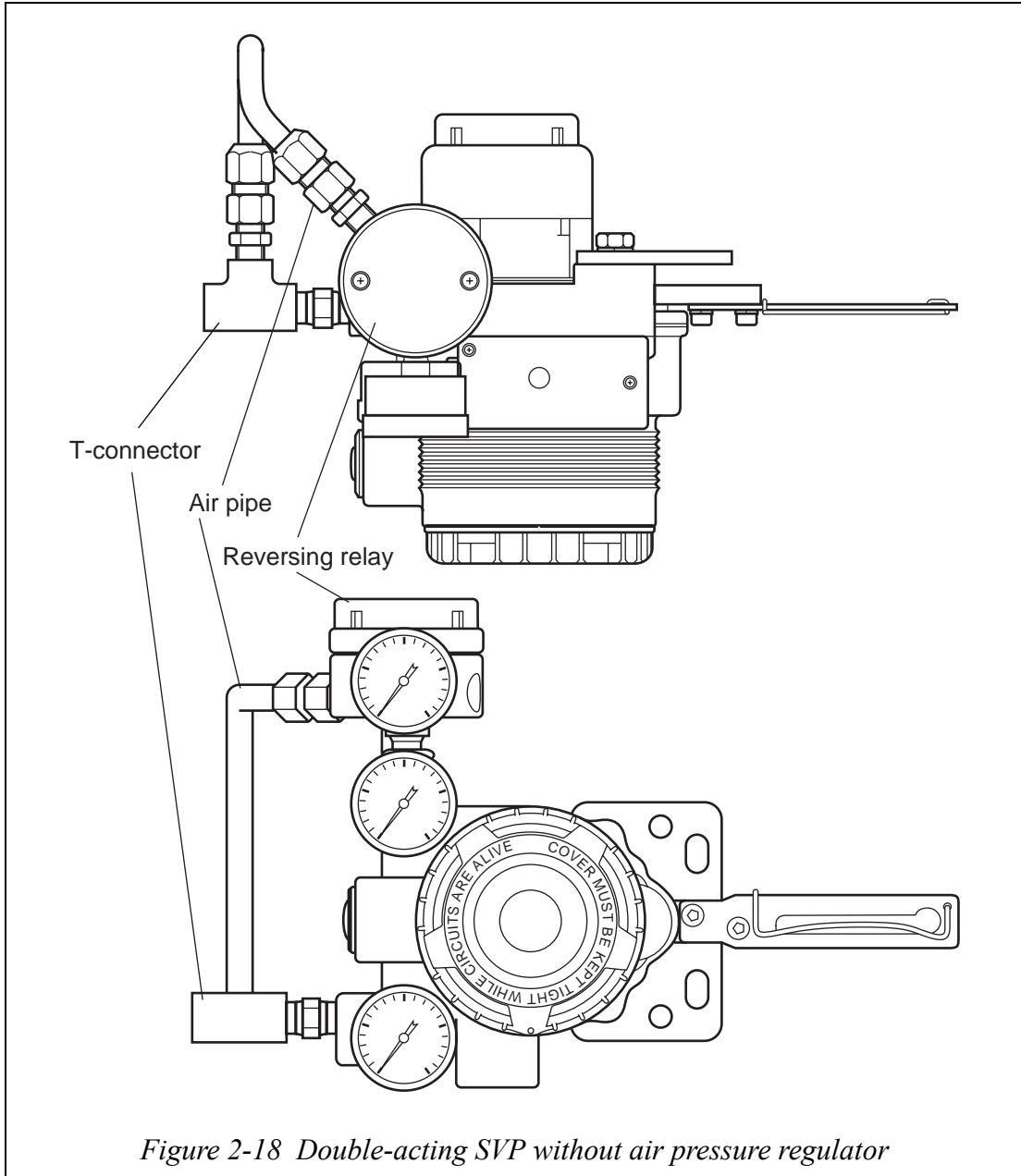

Figure 2-18 Double-acting SVP without air pressure regulator

Procedure for air pipe connection

Step	Procedure
1	Remove the dust plug from the output air connection on SVP.
2	Connect the joint to the air output connection using sealing tape. <i>~Note Sealing tape is preferable to solid or liquid sealant for pipe joints to SVP air connections. Prevent sealing tape/sealant from pipes.</i>
3	Connect the other air connection to each joints. <i>~Note</i> <ul style="list-style-type: none"> • <i>In case of using reversing relay, connection with actuator is selected as output air connection OUT1, OUT2 by valve action. Connect after confirming valve action.</i> • <i>Completely flash pipes before use, checking for burrs and other problems.</i> • <i>Use the right length of piping avoid access lengths.</i>
4	Check for leaks after installation.

Installing a double-acting SVP onto diaphragm actuator

Reverse-acting actuator

Connect **OUT1** of the reversing relay to the bottom actuator air port.

Connect **OUT2** of the reversing relay to the top actuator air port.

Direct-acting actuator

Connect **OUT1** of the reversing relay to the top actuator air port.

Connect **OUT2** of the reversing relay to the bottom actuator air port.

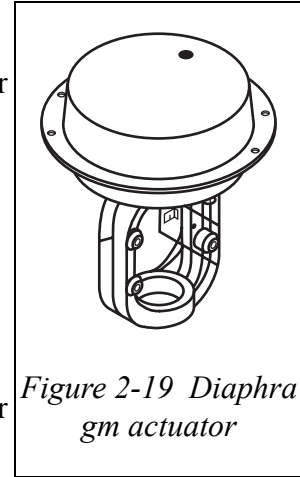

Figure 2-19 Diaphragm actuator

Installing a double-acting SVP onto a rotary actuator

Direct-acting actuator (clockwise rotation with increased pressure)

Connect **OUT1** of the reversing relay to the actuator chamber that rotates the trunnion clockwise with added pressure.

Connect **OUT2** of the reversing relay to the actuator chamber that rotates the trunnion counter-clockwise with added pressure.

Reverse-acting actuator (counter-clockwise rotation with increased pressure)

Connect **OUT1** of the reversing relay to the actuator chamber that rotates the trunnion counter-clockwise with added pressure.

Connect **OUT2** of the reversing relay to the actuator chamber that rotates the trunnion clockwise with added pressure.

~Note *If the actual air piping is different than described above, the functions of the SVP as a positioner will not be affected. However, various valve and SVP diagnostics usually performed with the SFC will not return accurate information. To utilize the capabilities of the SVP to the fullest, piping should match the diagrams and instructions above to maintain the relationship between the parameter settings described throughout this user manual.*

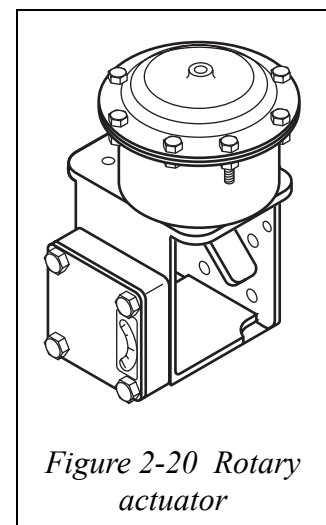

Figure 2-20 Rotary actuator

2-5: Electrical wiring

Wiring for waterproof SVP

⚠ WARNING

- ELECTRICAL SHOCK HAZARD! Turn off power before performing any wiring.
- When using an explosionproof SVP in a hazardous location, wiring must be performed in accordance with the instructions in “Wiring for explosionproof SVP” on page 2-24.
- Unused conduit ports must be completely sealed by attaching a blind plug.

Connection points

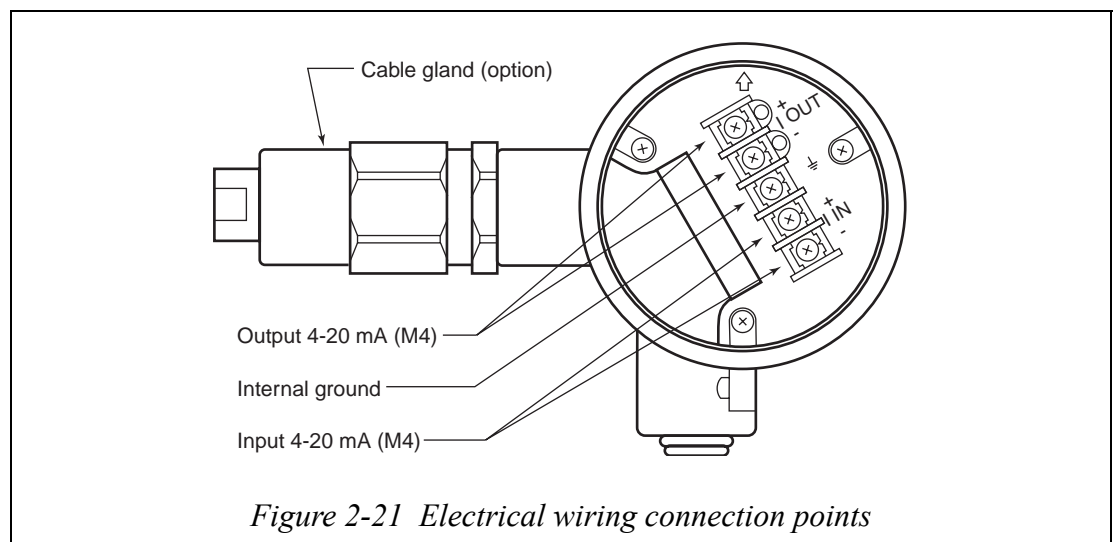

Electrical wiring types

There are 2 types of electrical wiring that differ by the purpose of the system.

- Systems that do not transmit a position signal (2-conductor connection)
- Systems that transmit a position signal (4-conductor connection)

Electrical wiring without travel transmitter (Model AVP300/302/200/202)

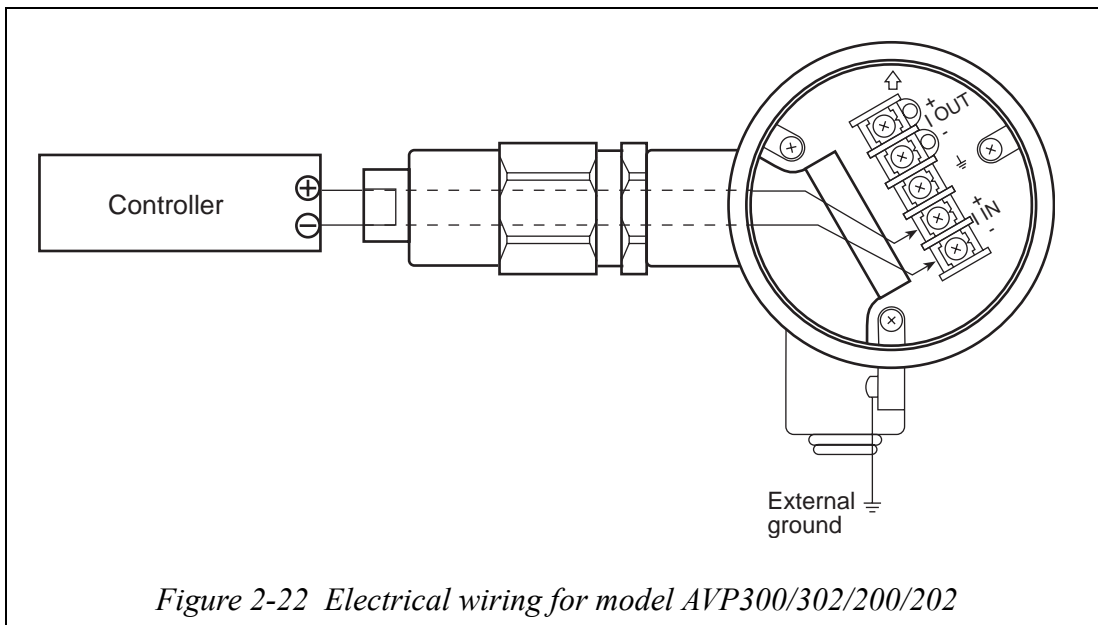

- Use only one of the two ground terminals (internal and external) to ground the SVP. Perform this work according to all local laws and ordinances governing electrical work.

With travel transmitter (Model AVP301/201)

Remove the terminal box cover and connect the wires as shown in the figure below.

- When a 4-conductor cable is used

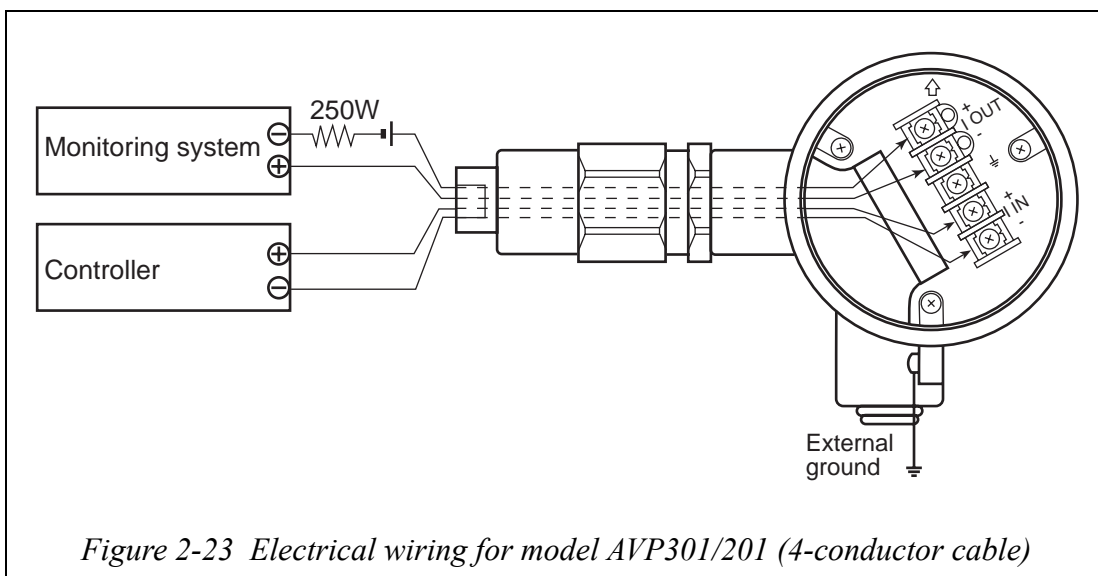

- When a 2-conductor cable is used

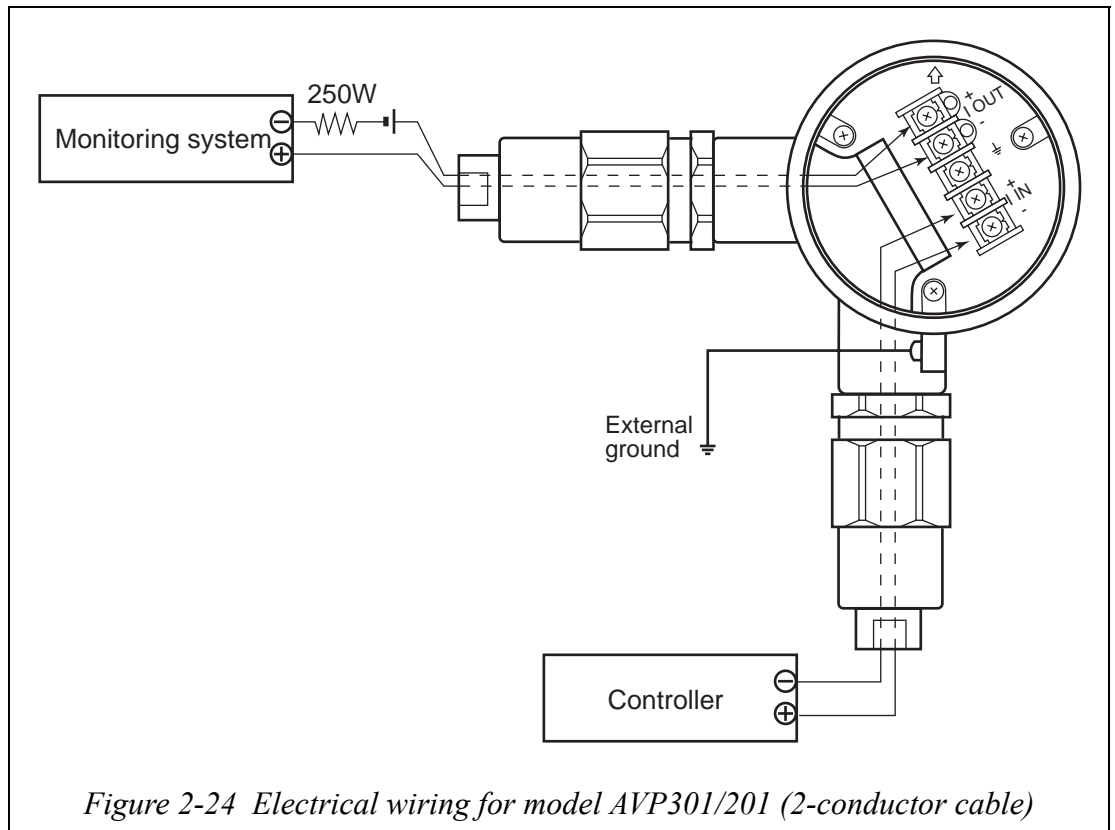

- Use the following wiring if the monitoring system is a voltage input (1 to 5V) device.

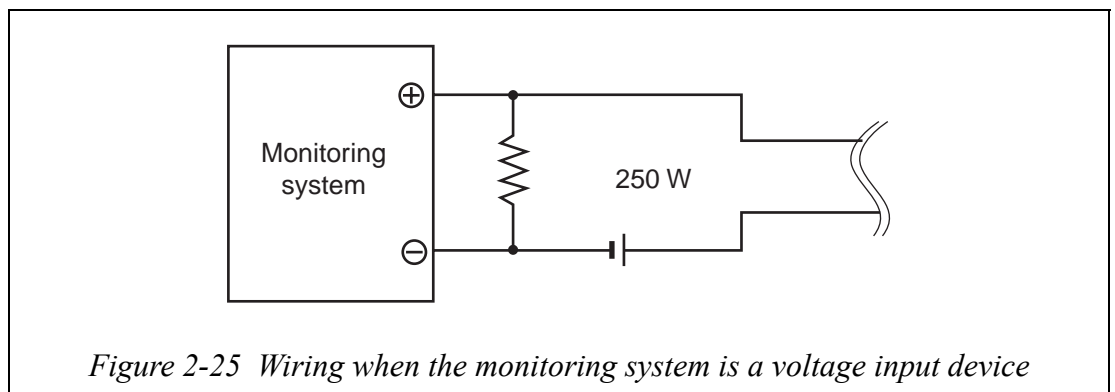

- Use only one of the two ground terminals (internal and external) to ground the instrument. Perform this work according to all local laws and ordinances governing electrical work.

Cables

- Use stranded cables having a conductor cross-section of 1.25 mm² and suitable for 600V such as shown in the conductor table in Article 310 of the NEC (National electric code). Outside diameter on cables must be 1/4 inch to 7/16 inch {7 mm to 12 mm}. Use shielded wires for locations exposed to electromagnetic noise.
- Select a sheath material that can withstand the cable installation environment (including the ambient temperature, corrosive gasses, corrosive liquids).
- Bring the cable to the terminal box through the conduit connection port (G1/2 internal thread, 1/2NPT internal thread, or M20×1.5 internal thread).
- Use cable with an outer diameter between 7 and 12 mm. If a pressure-resistant packing type cable adaptor is used, only use a packing that matches the outer diameter of the cable.
- We recommend the use of M4 screw size crimp-on terminals with an insulating sleeve.
- The maximum cable length is 1500 meters.
- Maximum permissible cable length is 1.5 km.
- Use the appropriate special-purpose cables for the wiring between the main unit at the position detector for separate type models (model AVP200/201).

CAUTION

Avoid installing cables near noise-making devices such as large capacity transformers and motors. Do not lay signal/control cables in the same tray or duct with noisy switching power cables.

- ~Note**
- *We recommend the use of conduits and ducts to prevent water and mechanical damage to electrical lines. Also, always use water-tight adaptors at conduit connection ports.*
 - *Use conduct and duct for locations exposed electromagnetic noise.*
 - *Always follow the technical standards for electrical installation for the wiring between the main unit at the valve travel detector for remote type models (AVP200/201/202).*

Electrical wiring procedure

Step	Procedure
1	Unscrew the Phillips terminal box cover screw on the terminal box cover.
2	Unscrew the terminal box cover and remove it. <i>~Note Be careful not to scratch painted surfaces with tools at this time.</i>
3	Remove one or both of the supplied Yamatake conduit connection blind plugs depending on how you plan to wire the SVP.
4	Insert cables into the conduit connection. Strip and attach the appropriate wires to the terminals, checking for polarity. Crimp contacts with insulated sleeves are recommended. <i>~Note Be careful not to damage the cable sheath at this time.</i>
5	Tighten the terminal screws fully, to a torque of 1.5 N*m (15 kgf*cm).
6	Apply adequate waterproofing measures to the conduits to prevent the entry of rainwater or water from any other source. <i>~Note We recommend the use of silicon resin based non-hardening seal materials.</i>
7	Screw the terminal box cover onto the SVP until it is hand-tight. Use the Phillips terminal box screw to secure the terminal box cover. <div data-bbox="528 1126 1469 1205" style="background-color: #cccccc; text-align: center; padding: 5px;">⚠ CAUTION</div> <div data-bbox="528 1205 1469 1294" style="border: 1px solid black; padding: 5px;">Be careful not to hurt your fingers on the edges of the cover and the screw threads.</div> <i>~Note Be careful not to scratch painted surfaces with tools at this time.</i>

Wiring for explosionproof SVP

Guidelines

Explosionproof requires special precautions and installation methods. Refer also to “Wiring for waterproof SVP” on page 2-19.

WARNING

- Tighten the case cover fully, to the end, and lock.
- Clearly delineate safety responsibilities in operating procedures. Especially, for an explosionproof positioner, specify locking of the cover of the positioner case.

Locking

Before cabling can be performed. Use a 3mm hexagonal wrench to open the locking structure.

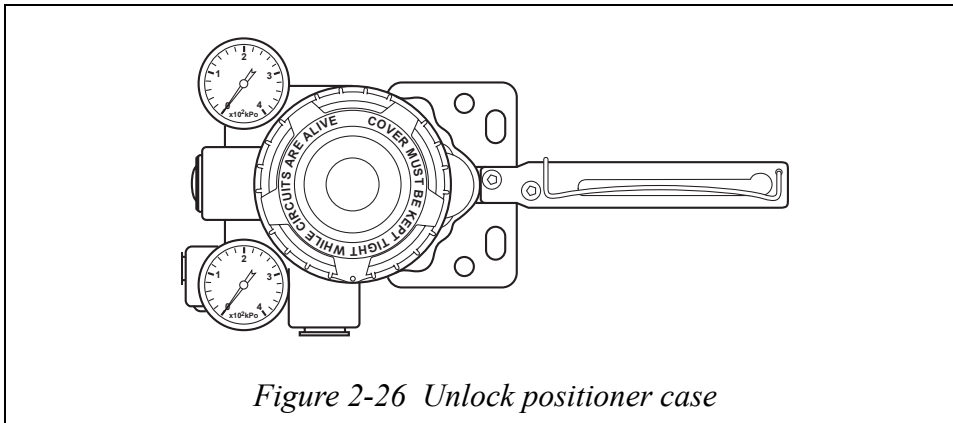

Figure 2-26 Unlock positioner case

Leading in external cables

Leading in cables to the equipment

Refer to the instructions in the chapter of About Explosionproof (“Explosion-protected models” on page ii) in the front of this manual.

Wiring for Intrinsically-safe SVP

Guidelines

The intrinsic safety requires special wiring precautions and installation methods. Also refer to “Wiring for waterproof SVP” on page 2-19.

WARNING

- Protect SVP from electrical or magnetic influence (such as coupling and induction) from other electrical circuits.
- Use certified zener barriers.

Wiring

FM

The wiring should comply with the “Installation requirements” on page vi

KEMA/ATEX

The barriers should be certified in accordance with the ATEX standards, with which the electrical parameters listed below have to be covered.

Item	Description
Model AVP300	Input circuit (terminals +/-IN) $U_i = 30V$, $I_i = 100 \text{ mA}$ (resistively limited), $P_i = 1W$, $C_i = 1 \text{ nF}$, $L_i = 0.2 \text{ mH}$ Output circuit (terminals +/-OUT) $U_i = 10 \text{ V}$, $I_i = 100 \text{ mA}$ (resistively limited), $P_i = 1W$, $C_i = 1 \text{ nF}$, $L_i = 0.3 \text{ mH}$ Both circuits shall be considered to be connected to ground from a safety point of view.
Model AVP301	Input circuit (terminals +/-IN) $U_i = 30V$, $I_i = 100 \text{ mA}$ (resistively limited), $P_i = 1W$, $C_i = 1 \text{ nF}$, $L_i = 0.2 \text{ mH}$ Output circuit (terminals +/-OUT) $U_i = 30V$, $I_i = 100 \text{ mA}$ (resistively limited), $P_i = 1W$, $C_i = 3 \text{ nF}$, $L_i = 0.2 \text{ mH}$ Both circuits shall be considered to be connected to ground from a safety point of view.
Model AVP302	Input circuit (terminals +/-IN) $U_i = 30 \text{ V}$, $I_i = 100 \text{ mA}$ (resistively limited), $P_i = 1W$, $C_i = 33 \text{ nF}$, $L_i = 0.2 \text{ mH}$ Output circuit (terminals +/-OUT) $U_i = 30V$, $I_i = 100 \text{ mA}$ (resistively limited), $P_i = 1W$, $C_i = 1 \text{ nF}$, $L_i = \text{negligibly small}$ Both circuits shall be considered to be connected to ground from a safety point of view.

NEPSI

SVP should be used with any of the following Zener barriers (which have been certified by NEPSI):

Model AVP300: Two each of MTL728, Z728, or LB928

Model AVP301: For input signal - Two each of MTL 728, Z728, or LB928
 For valve travel transmitter - MTL 728, Z728, or LB928

Refer to the user’s manual of each applicable barrier along with this manual.

The wiring capacitance should not exceed 0.06µF.

The wiring inductance should not exceed 1mH.

Use the earthing terminal to connect the earthing conductor.

Configuration of an intrinsically-safe system

System configuration

The system configuration is shown below. The diagram also shows the layout of an intrinsically-safe system consisting of a SVP, a portable setting display, a field type current indicator, and a Zener barrier. The system components except those connected to the non-intrinsically safe side of the barrier, must be certified by an authorized testing station.

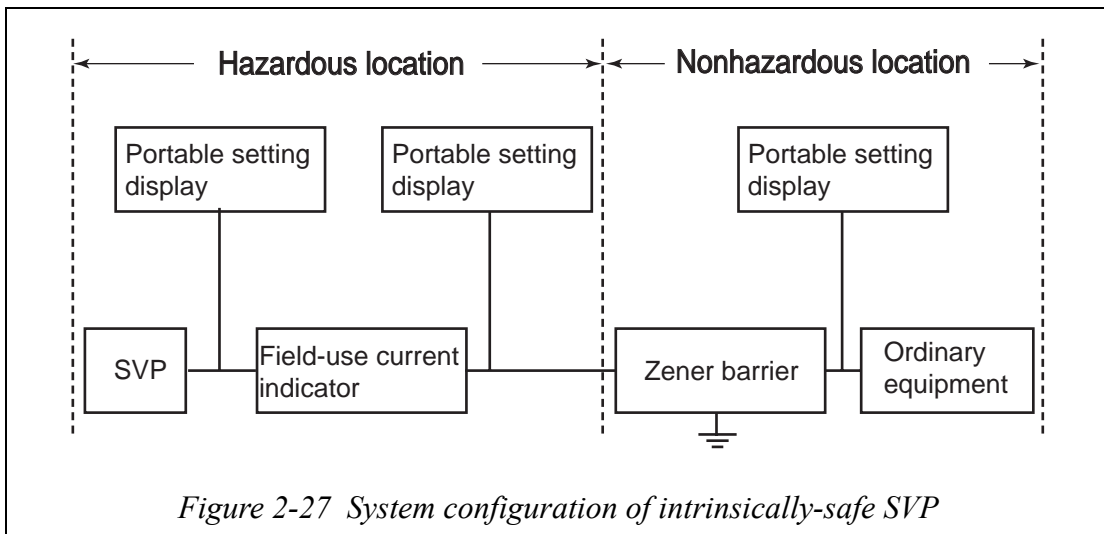

2-6: Control signal

The SVP requires a 4 to 20 mA DC control signal.

⚠ WARNING

Current should never exceed 24 mA DC.
The SVP requires a minimum of 3.85 mA DC to operate and SVP.

2-7: Travel transmission and load resistance

The load resistance on the two output terminals must be at least 250 Ω. Refer to the chart below for the prefer resistance.

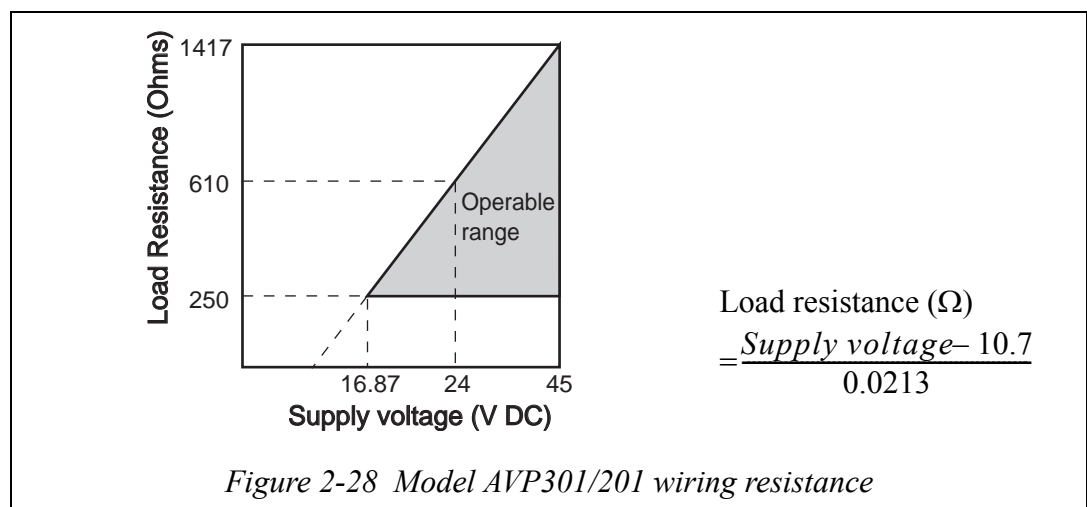

2-8: Cable gland and flameproof universal elbow for JIS Flameproof apparatus

JIS Flameproof SVP model is provided with a certified cable gland.

The cable gland seals the cable entering the SVP enclosure to withstand an internal explosion and protects the cable from damage mechanically and electrically.

Use the dedicated elbow if it is necessary to change the direction of the cable with these models.

⚠ WARNING

The constituent elements of the cable gland used with the integrated models (AVP300/301) and that used with the separated models (AVP200/201) differ. Be careful not to misuse these two adaptors.
The explosion-protection of the system will be invalid if any parts are no used properly.

Structure of the flameproof cable gland

The Flameproof cable gland is shown below in assembled and exploded views.

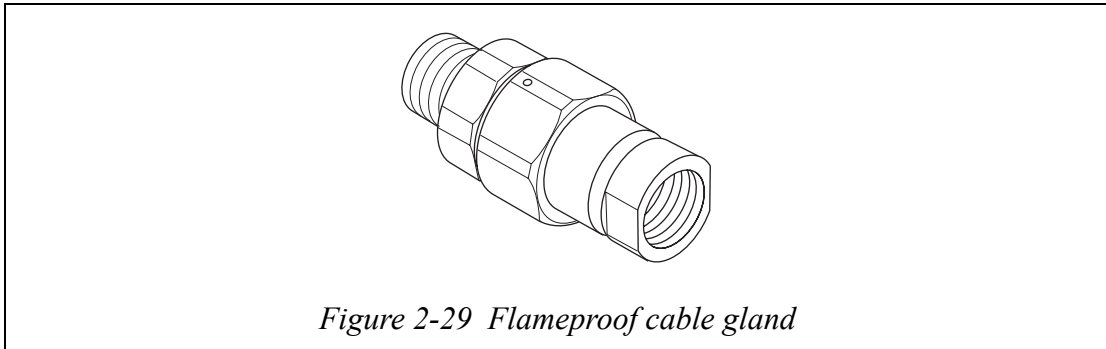

Figure 2-29 Flameproof cable gland

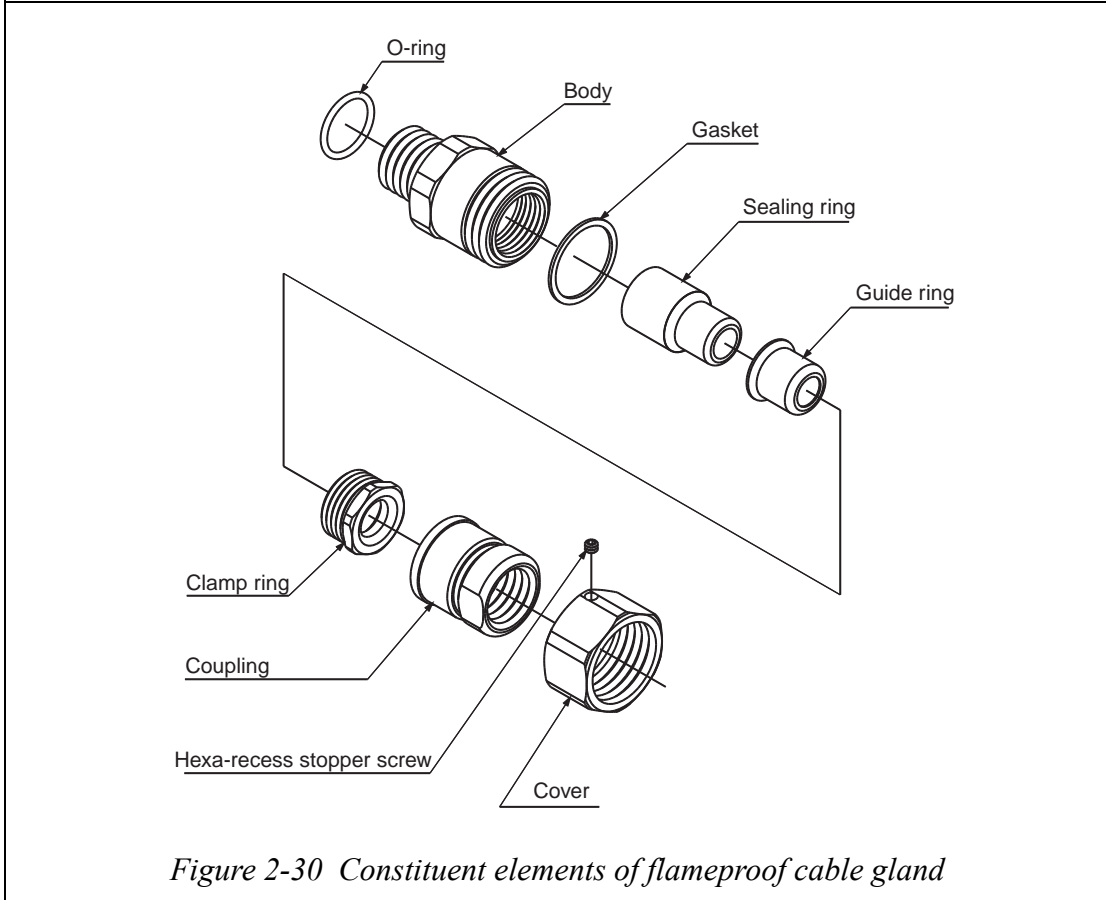

Figure 2-30 Constituent elements of flameproof cable gland

Structure of the flameproof universal elbow

The figure below shows the universal elbow.

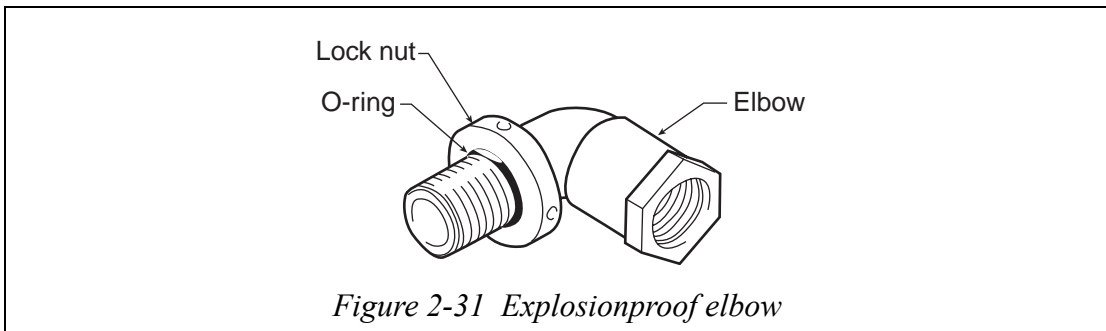
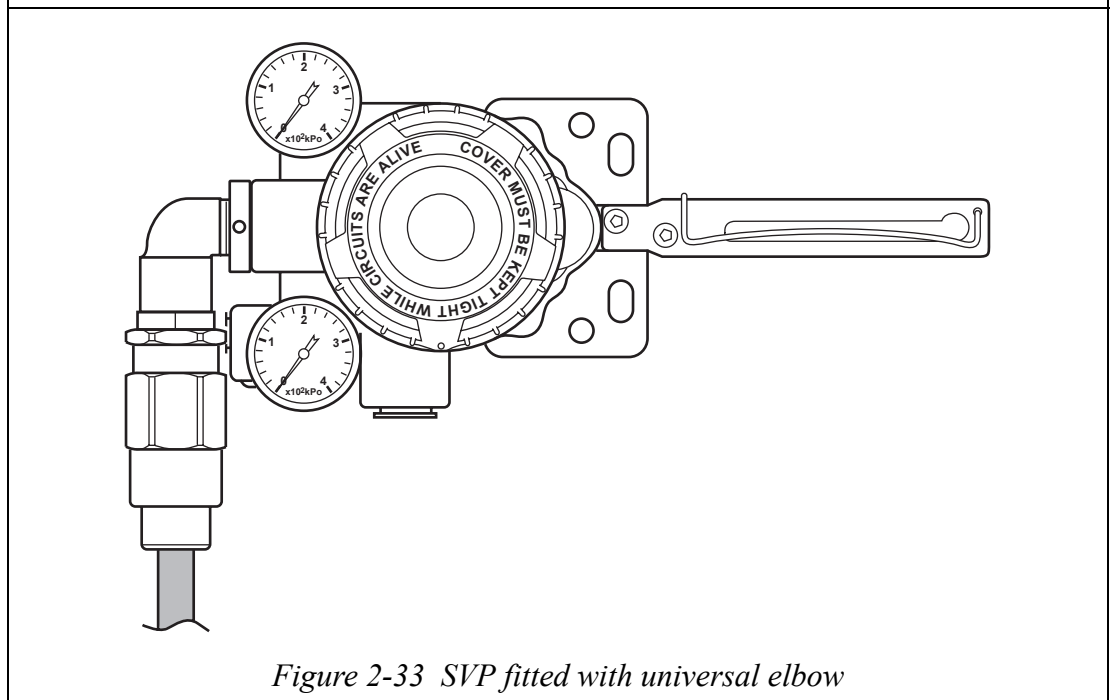
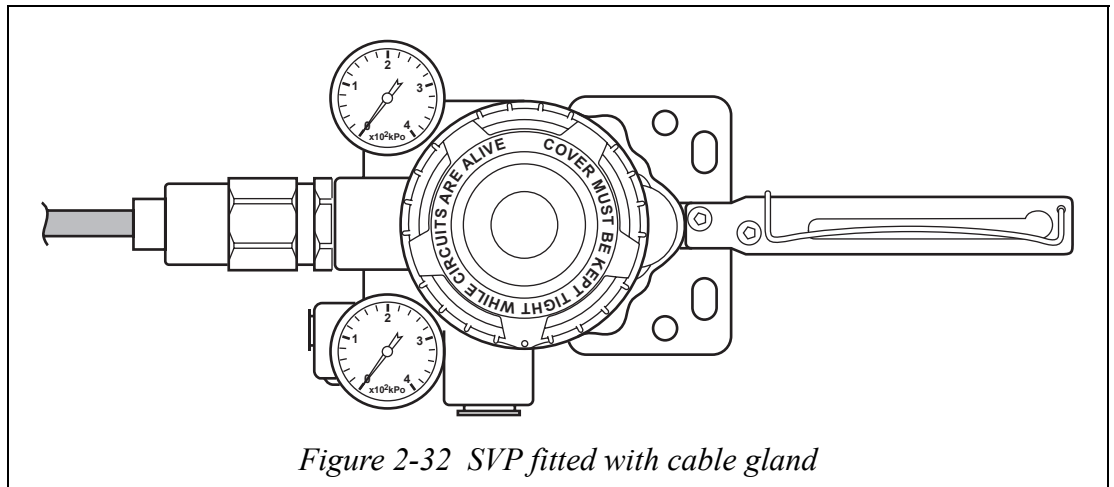

Figure 2-31 Explosionproof elbow



Mounting example

The flameproof cable gland and the universal elbow are used to connect the field wiring cable to the SVP enclosure as shown below.



Mounting procedure for flameproof cable gland

The procedure for mounting the flameproof cable gland is shown below.

Step	Procedure																		
1	<p>Firmly tighten the entry body on the connection port and the universal elbow to hold it in place.</p> <p>~Note <i>Apply adequate waterproofing to these parts. We recommend the use of silicone resin based non-hardening seal materials.</i></p>																		
2	<p>Refer to the illustrations and insert the cable carefully.</p> <div style="border: 1px solid black; background-color: #cccccc; padding: 5px; text-align: center; margin: 10px 0;">  CAUTION </div> <p>If the diameters of the cable and the packing do not match each other, the propagation of flame cannot be prevented. Refer to the table below and select a packing adaptor whose internal diameter matches the outer diameter of the cable.</p> <table border="1" style="width: 100%; border-collapse: collapse; margin: 10px 0;"> <thead> <tr> <th style="width: 33%;">Cable outer diameter (mm)</th> <th style="width: 33%;">Packing inner diameter (mm)</th> <th style="width: 33%;">Notes</th> </tr> </thead> <tbody> <tr> <td>7.0 to 8.0</td> <td>8</td> <td>Provided</td> </tr> <tr> <td>8.1 to 9.0</td> <td>9</td> <td>Provided</td> </tr> <tr> <td>9.1 to 10.0</td> <td>10</td> <td>Built in</td> </tr> <tr> <td>10.1 to 11.0</td> <td>11</td> <td>Provided</td> </tr> <tr> <td>11.1 to 12.0</td> <td>12</td> <td>Provided</td> </tr> </tbody> </table>	Cable outer diameter (mm)	Packing inner diameter (mm)	Notes	7.0 to 8.0	8	Provided	8.1 to 9.0	9	Provided	9.1 to 10.0	10	Built in	10.1 to 11.0	11	Provided	11.1 to 12.0	12	Provided
Cable outer diameter (mm)	Packing inner diameter (mm)	Notes																	
7.0 to 8.0	8	Provided																	
8.1 to 9.0	9	Provided																	
9.1 to 10.0	10	Built in																	
10.1 to 11.0	11	Provided																	
11.1 to 12.0	12	Provided																	
3	<p>Fit the coupling onto the clamp ring and tighten it down to hold it in place.</p> <div style="border: 1px solid black; background-color: #cccccc; padding: 5px; text-align: center; margin: 10px 0;">  CAUTION </div> <p>To prevent injury due to spark travel, be sure to tighten down the packing adequately.</p>																		
4	<p>Pass the cable through the body and insert it into the terminal box.</p>																		
5	<p>Screw the cover onto the body and tighten it down securely to hold it in place. Then, tighten the union nut's recess screw.</p>																		

Mounting procedure for flameproof universal elbow

The procedure for mounting the flameproof universal elbow is shown below.

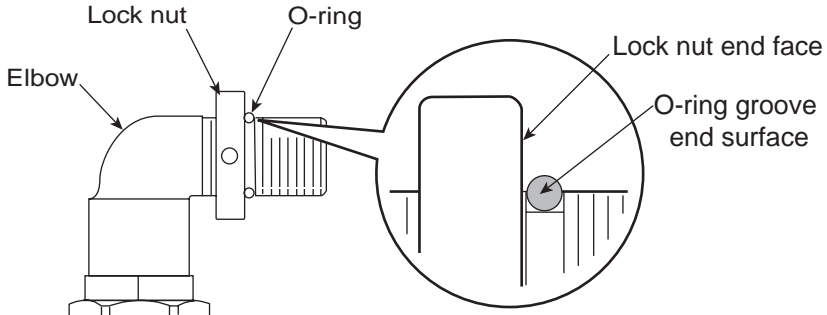
Step	Procedure
1	<p>Align the end surface of the lock nut with the end surface of the O-ring groove as shown below.</p>  <p style="text-align: center;"><i>Figure 2-34 Arrangement of lock nut and O-ring</i></p>
2	<p>Screw the flameproof universal elbow into the terminal box conduit connection port until the lock nut end surface hits the connection port end surface.</p> <p>~Note <i>Apply adequate waterproofing to these parts.</i></p>
3	<p>Turn the flameproof universal elbow to loose in the desired direction.</p> <p>~Note <i>Do not loosen it more than 1 turn.</i></p>
4	<p>Lock the flameproof universal elbow in place by tightening down the lock nut using the special tool.</p>

Lead-in of cable for flameproof models other than models in accordance with JIS

If the SVP is to be used under the authorization other than that for the JIS Flameproof standards, this the wiring of cables must be performed according to local regulations for electrical installations in explosive atmospheres.

Chapter 3: Operation

3-1: Auto-setup

Auto-setup is a unique program for automatically making various positioner adjustments.

After installing your SVP, auto-setup should be performed. The built-in zero-span adjustment switch on the SVP provides non-interactive closed and open valve position setting.

There are two ways to perform auto-setup.

- Using the external switch.
 - Using SFC (software version 7.5 or newer.)
Refer to “Chapter 4: Configuration using a SFC”.
- Using HART Communicator
Refer to “Chapter 5: Configuration using a HART Communicator”

- ~Note**
- *After auto-setup has completed, verify valve operation by varying the input signal.*
 - *After auto-setup, the SVP is calibrated to the fully shut (zero) and fully open (span) values of the valve. If the valve is not achieving the proper relationship between its travel and the control signal of the SVP, then adjust you need to adjust the zero-span manually.*

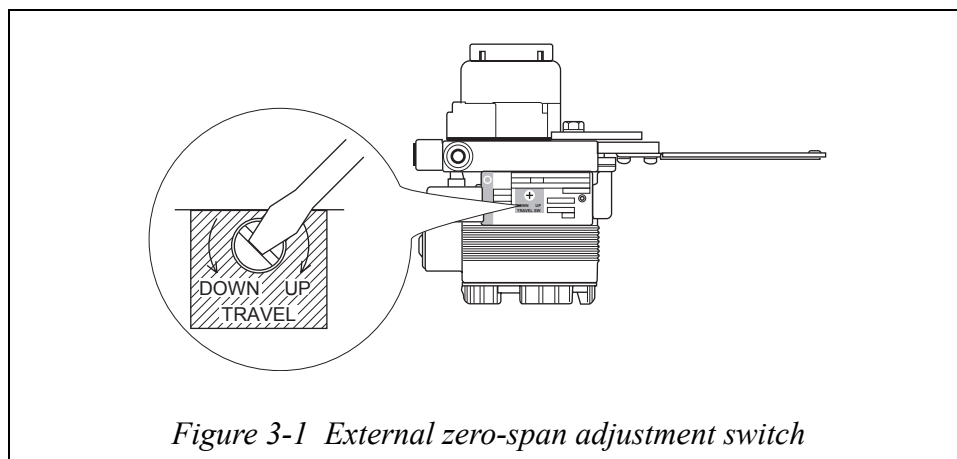

Figure 3-1 External zero-span adjustment switch

The following valve actuator characteristics are automatically detected during auto-setup:

- Zero-span adjustment
(However, as a default, the span point is taken to be 10% of the overstroke. If a span adjustment is performed after auto-setup completes, change the overstroke value and save the changed value.)
- Actuator operation setup

- Lower Range Value (LRV) and Upper Range Value (URV) of input signal
 If actuator operation is reverse operation: LRV = 4 mA, URV = 20 mA
 If actuator operation is direct operation: LRV = 20 mA, URV = 4 mA
- Actuator size setting
- Hysteresis setting
- Burnout setting of valve travel transmission

⚠ WARNING
While auto-setup is running, the valve cycles from open to closed. Take appropriate measures to prevent injury to personnel and adverse effects on the process.

SVP setting

If the valve action parameters set up for the SVP in Table 3-1: and Table 3-2: are the reverse values, see “(A) Basic data settings (SYSTEM CONFIG)” on page 4-14, in this document and set the valve action to the reverse settings.

If the valve action parameters set up for the SVP in “Table 3-1: Integral SVP setting” and “Table 3-2: Remote SVP setting” are the direct values, no further parameter settings are required. (The SVP is shipped from the factory set to direct mode.)

It is recommended that auto-setup and initial calibration of your SVP be performed using the external zero-span adjustment switch on the SVP.

You can also use a portable communicator to initiate auto-setup and initial calibration.

Because auto-setup and zero-span calibration must be observed for accurate valve positioning, these two steps will typically be performed by screwdriver using the external zero-span adjustment switch. Other functions including loop test, valve travel inquiry, split-ranging and tag number assignment require an SFC.

Table 3-1: Integral SVP setting

Lever	Valve direction	Input signal	SVP setting	
			Actuator action	Valve action
<p><i>Figure 3-2 Integral SVP setting</i></p>	Shut → Open	Direct Close: 20 mA, Open: 4 mA	Reverse	Reverse
		Reverse Close: 4 mA, Open: 20 mA	Direct	Reverse
	Open → Shut	Direct Close: 20 mA, Open: 4 mA	Direct	Direct
		Reverse Close: 4 mA, Open: 20 mA	Reverse	Direct

Table 3-2: Remote SVP setting

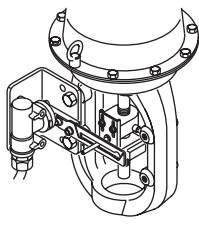
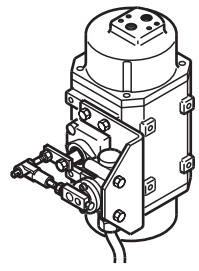
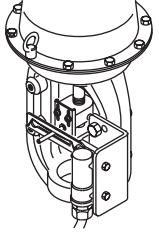
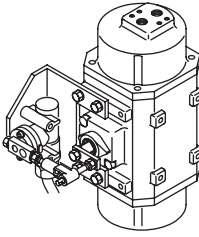
Valve travel	Direction position	Lever position	Lever movement	Valve direction	Input signal	SVP setting	
						Actuator action	Valve action ^{*i}
 <p>Figure 3-3</p>	Front	Right	Up→Down	Shut→Open	Direct action (Shut 20 mA, Open 4 mA)	Reverse	Reverse
					Reverse (Shut 4 mA, Open 20 mA)	Direct	Reverse
			Up→Down	Open→Shut	Direct action (Shut 20 mA, Open 4 mA)	Direct	Direct
					Reverse (Shut 4 mA, Open 20 mA)	Reverse	Direct
 <p>Figure 3-4</p>	Back	Left	Up→Down	Shut→Open	Direct action (Shut 20 mA, Open 4 mA)	Reverse	Reverse
					Reverse (Shut 4 mA, Open 20 mA)	Direct	Reverse
			Up→Down	Open→Shut	Direct action (Shut 20 mA, Open 4 mA)	Direct	Direct
					Reverse (Shut 4 mA, Open 20 mA)	Reverse	Direct
 <p>Figure 3-5</p>	Front	Left	Up→Down	Shut→Open	Direct action (Shut 20 mA, Open 4 mA)	Direct	Direct
					Reverse (Shut 4 mA, Open 20 mA)	Reverse	Direct
			Up→Down	Open→Shut	Direct action (Shut 20 mA, Open 4 mA)	Reverse	Reverse
					Reverse (Shut 4 mA, Open 20 mA)	Direct	Reverse
 <p>Figure 3-6</p>	Back	Right	Up→Down	Shut→Open	Direct action (Shut 20 mA, Open 4 mA)	Direct	Direct
					Reverse (Shut 4 mA, Open 20 mA)	Reverse	Direct
			Up→Down	Open→Shut	Direct action (Shut 20 mA, Open 4 mA)	Reverse	Reverse
					Reverse (Shut 4 mA, Open 20 mA)	Direct	Reverse

Note ^{*i}. Reverse means you push down to open, direct means you push down to close.

To initiate auto-setup using the external switch

Step	Procedure
1	Set the input signal to the SVP to 18 ± 1 mA DC
2	Using a flathead screwdriver, turn the zero-span adjustment screw clockwise (counter-clockwise for a FloWing rotary VFR valve and RSA actuators) until it stops.(90°)
3	Hold this position until the valve starts to move (approximately 3 seconds). This starts the auto-setup routine. Release the screwdriver.
4	The valve moves from fully shut to fully open twice. The valve then opens to about 50% and stays this way for up to three minutes.
5	Confirm that the auto-setup routine is complete by varying the input signals. The entire auto-setup procedure should take about three minutes.
6	If the input signal drops below 4 mA while auto-setup is running, then auto-setup will fail and must be restarted. After completing auto-setup, keep at least 4 mA of signal (power) for at least thirty seconds to make sure data and parameters are stored in SVP memory.
7	If you have an Smart Field Communicator (SFC) connected to your SVP during an auto-setup routine and you performed the auto-setup with a screwdriver, be sure to press the ID key on the SFC to read the new data from the SVP. <div style="text-align: center;">  </div> <p style="text-align: center;"><i>Figure 3-7 SFC ID Key</i></p>

- ~Note** (1) *While executing the auto setup program, do not set the input signal below 4 mA. (As long as the signal is in the range of 4-20 mA, changing the input signal during auto setup will not affect the program.)*
- (2) *After the operation has completed, check valve operation by varying the input signal and verifying that the valve goes to the correct position corresponding to the signal. If the span position has shifted, perform a span adjustment operation.*
- (3) *In some cases, the auto-setup routine will not properly detect your valve, especially if the valve's actuator is smaller than Yamatake's HA1 type actuator (diaphragm capacity of 850 cm^3 {52 inches³}) or the operation stroke is smaller than 14.3 mm {9/16 inch}. If this occurs “(B) Dynamic characteristics data settings (CTL CONFIG)” on page 4-18.*
- (4) *When you execute the auto setup program after communicating with the SFC, in order to read the original data you must press the ID button on the SFC.*

- (5) *There is a possibility that the forced open value (E) Forced fully open and fully closed settings (ON/OFF CONFIG) described on page 4-25, may change after performing the auto-setup operation.*
- (6) *If the booster relay is on, and is operating the auto-setup function, there might be a possibility of hunting. In this case, adjust the booster's sensitivity or refer to “(B) Dynamic characteristics data settings (CTL CONFIG)” on page 4-18 or “Dynamic chara (Dynamic characteristics)” on page 5-12 and adjust the dynamic characteristic manually.*
- (7) *When the SVP is purchased separately, its initial settings are set to those in the list of default values in “6-7: Table of default internal data values” of this manual. Because the default actuator direction is reverse, if you mount the SVP on the direct actuator the SVP will not work. Please be sure to execute the auto setup program before operation and be sure that appropriate settings are created in the SVP.*

3-2: Zero-Span adjustment

The SVP provides an external zero-span adjustment function.

This method is also useful when an SFC or HART Communicator is not available or when using an SFC or HART Communicator is not desirable (if the terminal box cannot be opened when an explosion-proof or intrinsically safe SVP is used in a hazardous environment, for example).

There are three ways to perform zero-span adjustment.

- Using the external switch
- Using communicator by input signal
 - SFC: See “(I) Zero-span adjustment” on page 4-30.
 - HART Communicator: See “Zero span adjust” on page 5-16.
- Using communicator by supply air
 - SFC: See “Using SFC with supply air” on page 4-35.
 - HART Communicator: Refer to “Chapter 5: Configuration using a HART Communicator”

Zero-Span adjustment using external switch

Procedure to adjust valve to fully shut position (zero)

The procedure for adjusting the valve to the fully shut position (zero) is given below.

Step	Procedure
1	Input current signal that corresponds to the valve being fully shut from the controller (constant-current supply). (Example: 4 mA)
2	Adjust the valve fully shut position by turning the adjustment screw in the clockwise or counterclockwise direction. See Figure 3-8 and Figure 3-9 for how to use external adjustment screw. (If the forced shutdown function is operating, the valve will not move. To change the forced shutdown setting, see “(E) Forced fully open and fully closed settings (ON/OFF CONFIG)” on page 4-25. The default value is set to 0.5%.)

Procedure to adjust valve to fully open position (span)

The procedure for adjusting the valve to the fully open position (span) is given below.

Step	Procedure
1	Input current signal that corresponds to the valve being fully open from the controller (constant-current supply). (Example: 20 mA)
2	Adjust the valve fully open position by turning the adjustment screw in the clockwise or counterclockwise direction. See Figure 3-8 and Figure 3-9 for how to use external adjustment screw.

~Note *After completing the valve fully open and fully closed position (zero and span) adjustments, check valve operation by varying the input signal and verifying that the valve goes to the correct position corresponding to the signal.*

After completing the adjustments, hold the input signal at a level over 4 mA for at least 30 seconds to write the set positions into a non-volatile memory of SVP.

When adjusting the span after the auto-setup, the forced fully open value (refer to “(E) Forced fully open and fully closed settings (ON/OFF CONFIG)” on page 4-25) will automatically set to -1% of the overstroke. Reset the fully open value if necessary.

Adjustment direction

The zero-span adjustment screw functions as an on/off switch. When rotated 90° either clockwise or counterclockwise, the switch is on and the feedback lever moves upward or downward respectively. Adjust the position by turning this switch on and off repeatedly. The position of the feedback lever is memorized when the switch is turned off.

Since the zero point and span adjustments do not interfere with each other, they can be adjusted independently.

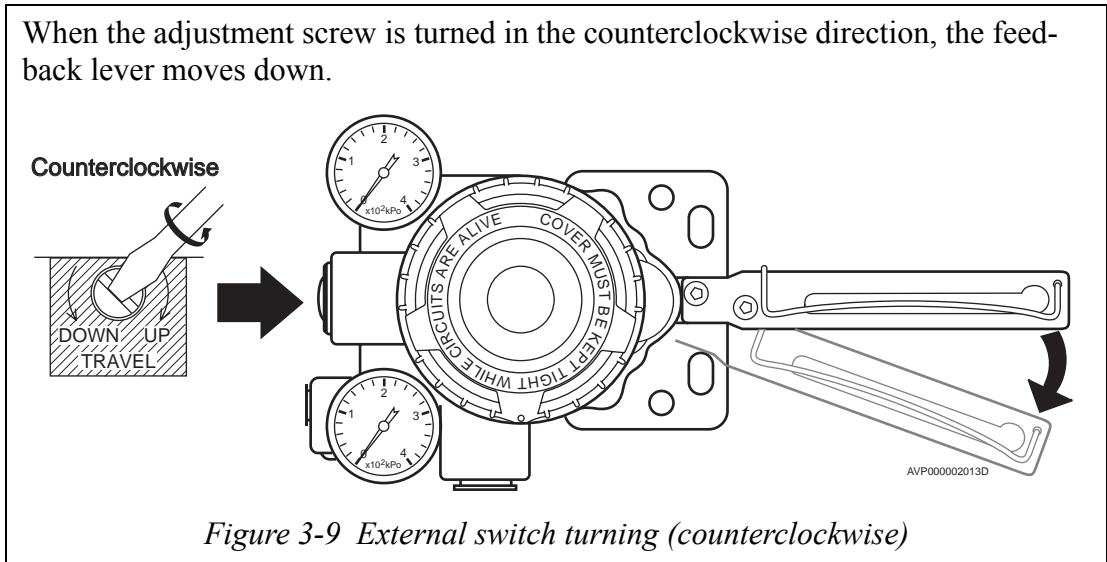
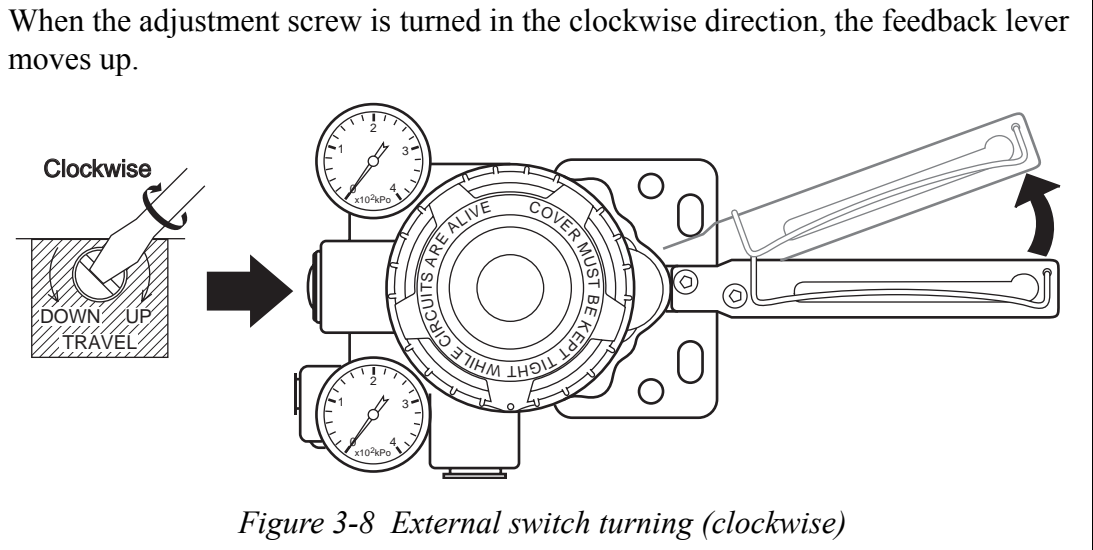

~Note *The external zero-span adjustment structure uses a magnet to turn a reed switch on and off*
The external zero-span adjustment function uses the input signal to identify whether a valve fully open position (span) adjustment or a valve fully closed position (zero) adjustment is to be performed. If the input signal is not within the range of ± 1 mA of the current values that correspond to the valve open and closed position, this function will not operate.

3-3: Starting operation

Items to verify before setup

Before setting up for this adjustment, verify the following.

- The air supply system has been completed and the air supply pressure required by the actuator is being supplied. (See “Connecting the air supply” on page 2-5.)
- Connection with the SFC has been completed. (See “4-3: Connecting the SFC” on page 4-4.)
- The SVP and the SFC are communicating. (See “4-7: Function setup and modification” on page 4-10.)

Verification procedure

The procedure for verifying the settings data is shown below.

Step	Procedure
1	Set the input signal from the controller (constant-current supply) to a value so that the valve will have an actual position of 50%.
2	<p>Refer to “4-12: Data Printing” on page 4-48, and print out the SVP internal data, and verify that it matches the specifications of the SVP itself and the control valve used.</p> <p>Also, verify that the SVP input/output relationship characteristics and other aspects are operating as they are set to operate. If any discrepancies are found, reset the relevant settings and verify operation again.</p> <p><i>~Note If the SFC does not have a printer attached, Refer to “Chapter 4: Configuration using a SFC”, and verify the internal data on the SFC screen.</i></p> <ul style="list-style-type: none"> • We strongly recommend using the SFC with a printer attached.

Verifying the operation

Verifying EPM (Electro-pneumatic converter module) operation

The procedure for verifying EPM operation is given below.

Step	Procedure
1	Set the input signal from the controller (constant-current supply) to a value so that the valve will have an actual position of 50%.
2	Refer to “4-11: Verifying operating data” on page 4-45, Verifying the Operating Data, and verify that the EPM drive signal is $50 \pm 25\%$. ~Note <i>If the above condition is not meant, it means that the EPM balance adjustment has slipped. Refer to “6-4: EPM (Electro-pneumatic Converter Module) balance adjustment” on page 6-4, EPM (Electro-pneumatic Converter Module) Balance Adjustment, and adjust the balance.</i>

Verifying self diagnostics

The procedure for verifying the results of the self diagnostics is given below.

Step	Procedure
1	Set the input signal from the controller (constant-current supply) to a value so that the valve will have an actual position of 50%.
2	Refer to “4-11: Verifying operating data” on page 4-45, Verifying the Operating Data, perform the self diagnostics (status check) describe there, and verify that the diagnostics pass. If the result is anything other than “OK”, Refer to “Chapter 7: Troubleshooting” on page 7-1. ~Note <i>This can also be verified from the printed output acquired when checking the settings data immediately prior to this operation.</i>

Verifying SVP operation

The procedure for verifying SVP operation is given below.

Step	Procedure
1	Vary the input signal from the controller (constant-current supply) and verify that the position of the control valve changes according to the set characteristics. If the system does not operate correctly, Refer to “Chapter 7: Troubleshooting” on page 7-1
2	If the system does operate correctly, restore the electrical wiring to its original state and tighten down the cover firmly. (Refer to “2-5: Electrical wiring” on page 2-19)

Operation startup procedure

The SVP and the control valve form a manipulator used in process control. Always observe adequate safety precautions when starting control valve operation using the SVP.

~Note *If an explosionproof SVP is used in a hazardous environment, pay particular attention to how well electrical connection components (adapters, blind plugs, and similar equipment) are tightened down, and to how well covers are tightened down as well. Verify the following points before starting operation.*

The verification procedure is given below.

Step	Procedure
1	Verify that the SVP is installed correctly. Verify that nothing interferes when the control valve operates.
2	Verify that the SVP electrical wiring is installed and connected securely. Also verify that the air lines are installed and connected securely and that there are no air leaks.
3	Verify that the valve operates as set up according to the input signal.

After the above items have been checked, operation of the SVP and control valve may be started.

Stopping operation

The procedure for stopping operation is given below.

Step	Procedure
1	Stop operation of the process. (Move each valve to the air fail position.)
2	If position transmission output is used, switch the host control mode to manual.
3	Turn off the input signal (power supply) to the SVP.
4	Turn of the air supply to the SVP. ~Note <i>If the SVP is installed in an adverse environment, for example, in a corrosive atmosphere, we recommend not turning off the air supply to prevent corrosive gasses from entering the SVP.</i>

Chapter 4: Configuration using a SFC

4-1: SFC functions

The Smart Field Communicator (SFC) can be used to read out and write the internal data in the model AVP300/301/200/201. The SFC and the SVP communicate over the SVP output signal lines. The SFC can be used at a location remote from the SVP itself to read the output values and to print out the internal data.

The following operations are possible using the SFC communicating with the SVP.

Starting communications

- Starting communications
- Registering and changing the tag number

Function setup and modification

- (A) Basic data settings (SYSTEM CONFIG)
- (B) Dynamic characteristics data settings (CTL CONFIG)
- (C) Flow characteristics selection (CONFORM CONFIG)
- (D) Flow characteristics conversion data settings (CNV CONFIG)
- (E) Forced fully open and fully closed settings (ON/OFF CONFIG)
- (G) SVP internal temperature display
- (H) Maintenance mode (MAINTE MODE)
- Setting and adjusting the current input range [SVP/SVT]
- IIN/VTD simultaneous ranging [SVP/SVT]

Verifying operating data

- Verifying the current input value [SVP]
- Verifying the position [SVP]
- Verifying the EPM (Electro-Pneumatic converter Module) drive signals [SVT]
- Verifying the position transmission output value [SVT]
- Self diagnostics [SVP/SVT]

Data Printing

- Configuration Printout (Verifying all data at once) [SVP/SVT]
- Continuous Response Printout (Action Print) [SVP/SVT]

Other functions

- Current input correction (IIN CORRECT)
- Current output correction (IOUT CORRECT)
- Simulated current input [SVP]
- EPM simulated drive signal setting [SVT]
- Simulated position transmission output [SVT]
- Restoring factory data [SVP/SVT]
- Switching between analog and digital output [SVP/SVT]
- Setting the digital output format [SVP/SVT]

 **WARNING**

Ensure that a sudden action of the valve, caused by a communicator operation, will not in any way harm people or equipment.

When auto-setup is started, it will open and close the valve regardless of input signal status. Take necessary precautions before starting auto-setup to prevent any harm to process operations or to personnel.

Always use the communicator in a non-hazardous location, otherwise an explosion can result from an electrical discharge.

- Use a model SFC160/260. Use software version 7.5 or later.
- See the following item if you will be using an model SFC160/260 with a software version earlier than version 7.5.

~Note *To communicate with the SVP, power must be supplied to both the SVP input side and output side. Communication is not possible using only the output side. If a 4-20 mA DC signal cannot be input from the controller, connect a constant-current power supply (such as a CCS) to the input signal terminals. The wiring from the controller must be disconnected from the terminals at this time. However, if model with no position transmission signal (the model AVP300/302, AVP200/202) is used, the output side power supply is not required.*

When connecting the SFC to the SVP, always turn the SFC power off before making the connections and always check the connections again before turning the power on. (Do not use an SFC that has an SPS function.)

Before starting communication between the SFC and an SVP in an analog output system, always switch the host system control mode to manual control mode.

Do not allow the position transmission loop supply voltage to exceed 45V DC. In particular, be careful not to accidentally use a 100VAC power supply.

The SFC was developed not only for the SVP, but as a communicator for Yamatake's other smart field equipment as well. Refer to the SFC user's manual (document number CM2-SFC100-2001) if further details are required.





4-2: Using the SFC with software versions earlier than version 7.5

Keep the following points in mind when using a model SFC160/260 with a software version earlier than version 7.5.

- Do not use the following function settings, which are not supported by the SVP.

Position transmission output range setting





- If a setting according to the actual position

(in SVT mode, press  or  →  → ) is performed, the auto-setup function will operate.

WARNING

When the auto-setup function operates, the valve may move suddenly from fully closed to fully open. This can result in injury if a person's hand gets caught in the equipment or may affect the process, and lead to personal injury.

- The arbitrary position setting function

(in SVT mode, press  or  →  → ) does not change the SVP internal data.

Limit value setting (LIMIT CONFIG)

Changing the upper limit value or the lower limit value will change the SVP zero and span points.

WARNING

When a limit is changed, the valve may operate suddenly. This can result in injury if a person's hand gets caught in the equipment, or it may affect the process and lead to other personal injury.

Setting the position transmission output damping time constant (DAMP)

Changing the damping time constant will not change the SVP internal data.

The following points must be observed if the SFC is used with an SPS board (power supply board) attached.

The model AVP300/302, 200/202 products cannot communicate without modification. Remove the SPS board from these positioners. To remove the SPS board, consult your Yamatake service representative.

(The model AVP301/201 products that include a position transmission function that can be used without removing the SPS board.)

4-3: Connecting the SFC

This section describes the wiring required for communication between the SVP and the SFC. The SFC is connected to the SVP by connecting the SFC communication cable to the SVP output (position transmission signal) 4-20 mA signal line.

The SFC communication cable can also be connected to the test pin attached to the SVP output signal terminal (IOUT).

Types of wiring

There are two techniques for connecting the SFC to the SVP.

- When the position transmission function is not installed
- When the position transmission function is installed

When the position transmission function is not installed

Remove the terminal box cover and connect the wiring as shown in the figure below.

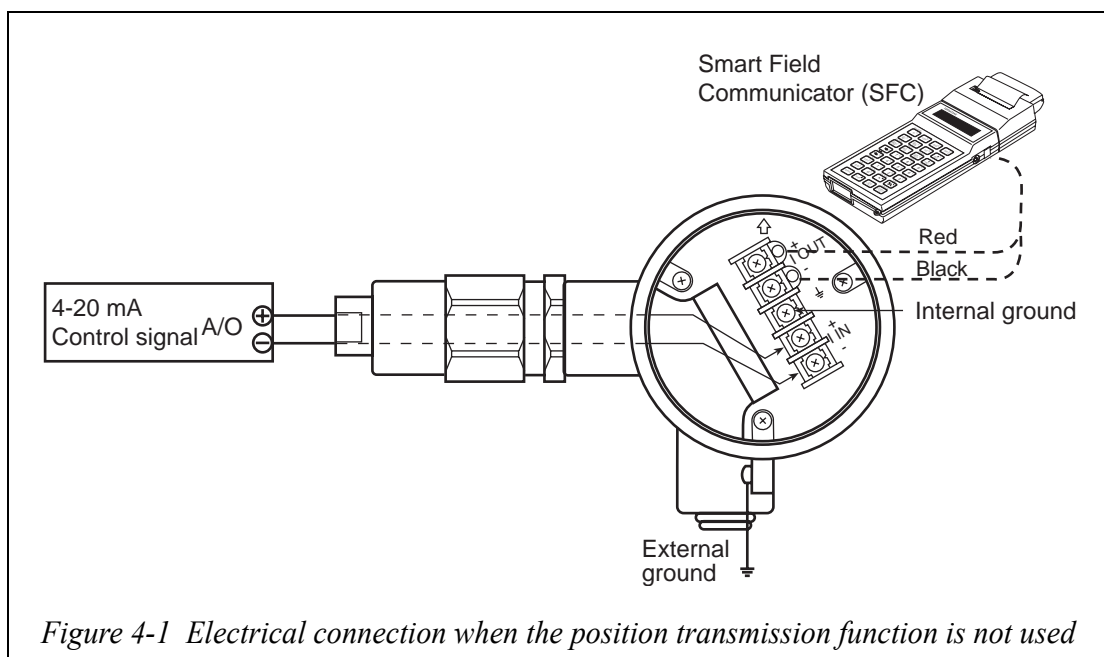

- ~Note**
- Check the polarity carefully when making these connections.
 - If the SFC includes the SPS function, software version 7.5 or later must be used.

When the position transmission function is installed

Remove the terminal box cover and connect the wiring as shown in the figure below.

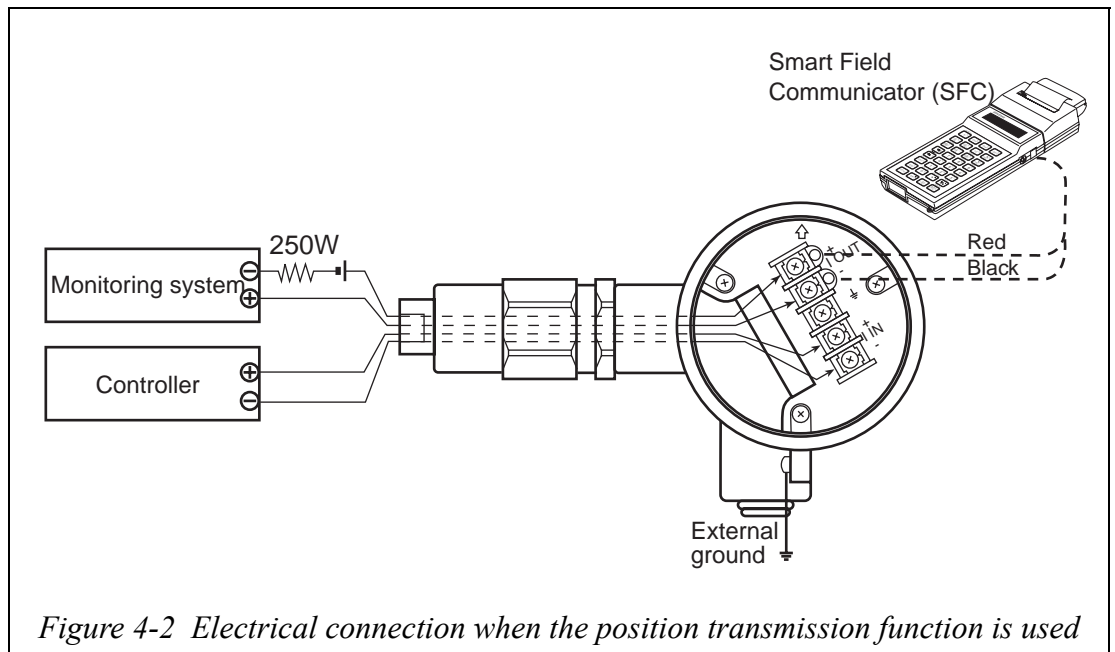

- Check the polarity carefully when making these connections.
- If the SFC includes the SPS function, always disconnect the lines from the receiver, even if power is not supplied to the position transmission loop.
- If the SFC does not include the SPS function, power must be supplied to the position transmission loop. If power cannot be supplied, connect a 24V DC power supply through a 250 Ω resistor. In this case, the wiring from the receiver must be disconnected.

4-4: Relationship between the mode and data settings

SVP mode and SVT mode

There are two modes, which differ in their functionality, for communication between the SFC and the SVP: SVP mode and SVT mode.

SVP mode is mainly used for data settings and modifications related to positioner functions (input system).

SVT mode is mainly used for data settings and modifications related to position transmission functions (output system).

Mode display

The mode is displayed at the upper left of the SFC screen.

- SVP mode.....

SVP	PCV-123
READY...	

- SVT mode.....

SVT	PCV-123
READY...	

Modes and functions



Mode	Functions
[SVP]: SVP mode only [SVP] is shown in the header.	<ul style="list-style-type: none"> • Setting the current input range • Setting and adjustment of the valve fully open and fully closed positions • Simultaneous setting of the input current and the valve fully open and fully closed positions • Current input display • Position display • Current input correction • Simulated current input
[SVT]: SVT mode only [SVT] is shown in the header.	<ul style="list-style-type: none"> • Displaying the EPM (electro-pneumatic converter module) drive signal • Displaying the position transmission output signal • Current output correction • Inputting a simulated drive signal to the EPM (electro-pneumatic converter module) • Simulated current output
[SVP/SVT]: Can be used in either mode [SVP/SVT] is shown in the header.	<ul style="list-style-type: none"> • All other functions

Mode switching procedures



Press  to switch the SVP mode from SVP mode to SVT mode.

The procedures for switching the mode are given below.

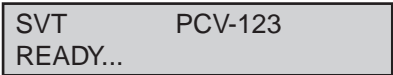
- When switching from SVP mode and SVT mode

Step	Operation	SFC screen
1	Verify that the SFC display screen reports that it is in SVP mode command wait state. • If this is not displayed, press  .	
2	Press  . • The mode will be switched to SVT mode. • The mode will be displayed at the upper left of the screen.	

- When switching from SVT mode to SVP mode

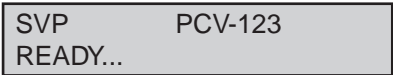
Step	Operation	SFC screen
1	Verify that the SFC display screen reports that it is in SVT mode command wait state. • If this is not displayed, press  .	
2	Press  . • The mode will be switched to SVP mode. • The mode will be displayed at the upper left of the screen.	

4-5: Starting communications





Before starting communications

Verify the following points before starting any communications operations.

- Connection with SVP has been completed (See “4-3: Connecting the SFC” on page 4-4.)
- The input signal (power supply) from the controller (constant-current supply) has been provided.

~Note *To communicate with the SVP, power must be supplied to both the SVP input side and output side. Communication is not possible using only the output side. If a 4-20 mA DC signal cannot be input from the controller, connect a constant-current power supply (such as a CCS) to the input signal terminals. The wiring from the controller must be disconnected from the terminals at this time. However, if model with no position transmission signal (the model AVP300/302, 200/202) is used, the output side power supply is not required. When connecting the SFC to the SVP, always turn the SFC power off before making the connections and always check the connections again before turning the power on. (Do not use an SFC that has an SPS function.)*











Procedure

Step	Operation	SFC screen
1	Turn on the SFC. • The SFC will ask if the position transmission loop is in manual mode or not.	LOOP IN MANUAL ?
2	If the position transmission host system is in manual control mode, press  .	PRESS ID
3	Press  for no-output or analog output systems. Press  +  for digital output systems. ~Note <i>Communication takes 10 to 45 seconds.</i>	SVP TAG No. SVP PCV-123 Analog output system SVP DE TAG No. SVP DE PCV-123 Digital output system
4	To change the tag number, proceed to the following page. If you do not need to do so, press  . • The SFC will go to the command wait state. • The SFC goes to the SVP mode immediately after the power is turned on.	SVP PCV-123 READY...

4-6: Registering and changing the tag number

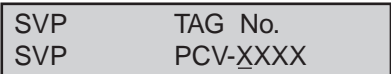
This procedure is used to register or change the tag number (the number of the communicating device) after the start of communication.

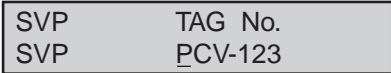
Procedure

Step	Operation	SFC screen
1	Verify that the SFC screen is in the state shown at the right. <ul style="list-style-type: none"> If the SFC screen is not in the state shown at the right, refer to the previous item, "Starting Communication", and start communication with the SVP. 	
2	Press  for no-output analog output systems. Press  +  for digital output systems. ~ Note Communication takes 10 to 45 seconds. <ul style="list-style-type: none"> The tag number will be displayed if it is already registered. 	 Analog output system  Digital output system
3	Enter the tag number (up to 8 alphanumeric characters).	
4	Press  after entering the tag number.	
5	After verifying the tag number, press  .	

4-7: Function setup and modification

The functions that can be set up and modified in each mode are shown below.

The basic functions for assuring normal operation of the SVP are set up in the configuration settings (SVP CONFIG).

Hierarchical CONFIG structure

The configuration system has the hierarchical structure shown below.

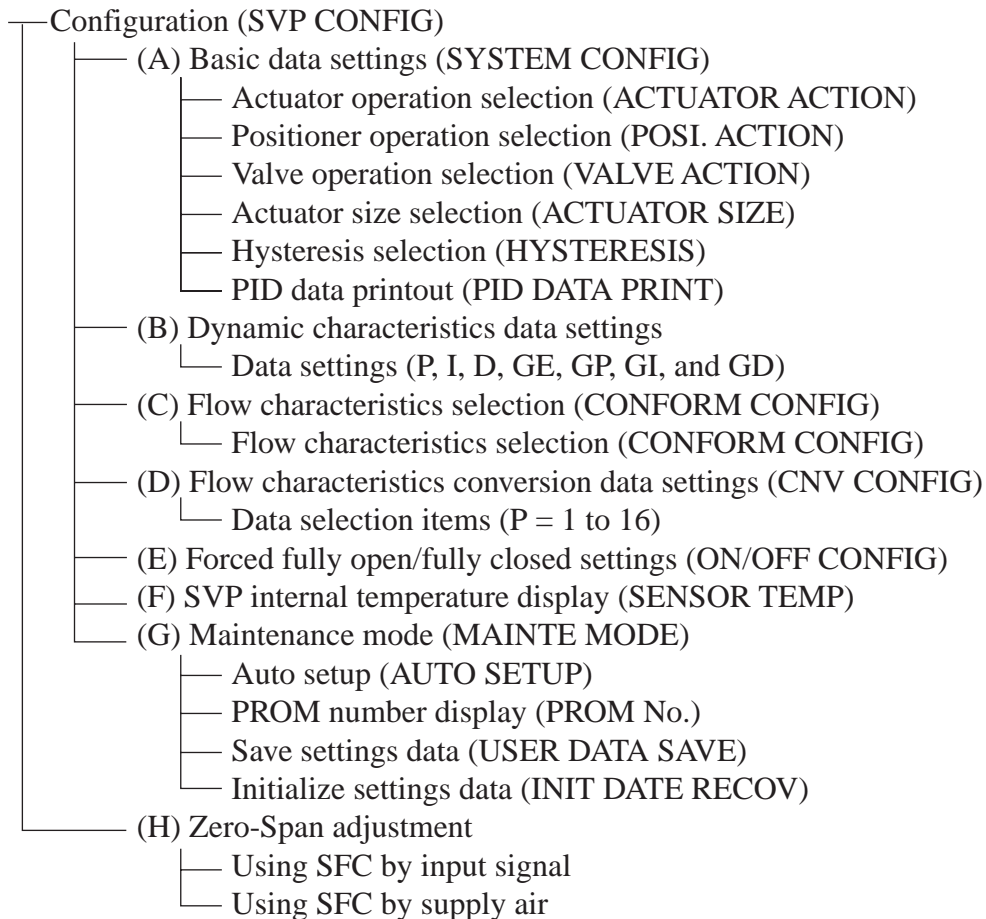











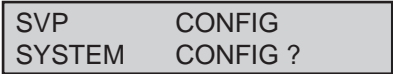

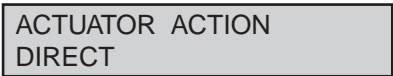

Notes on configuration settings

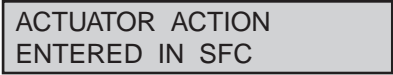
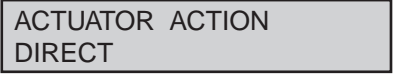
This section presents the basic operating procedures for, and notes on, entering and leaving configuration mode, and setting and confirming data.

Basic procedure for configuration settings

The basic procedure for setting configuration items is shown below. The actual operations differ slightly for different items (in particular, maintenance mode). See the flowcharts for the individual items for details.

Step	Operation	SFC screen
1	Verify that the SFC is in the command wait state.	
2	Press  . <ul style="list-style-type: none"> The SFC will enter configuration mode. The main item will be displayed in the lower line on the screen. 	
3	Use the  and  keys to select the item or parameter you want to set or change.	
4	Modify and enter parameter values with the  and number keys.	
5	Press  to confirm the setting or modification. <ul style="list-style-type: none"> This must be performed to enter or change parameter values. This only confirms the data. It does not register the value in the SVP. Repeat steps 4 through 6 to continue setting or changing parameter values within the same main item. 	 After 2 seconds: 
6	Use the  and  keys to switch to the screen display shown at the right.	

Step	Operation	SFC screen
7	Press  . <ul style="list-style-type: none"> The confirmed data will be stored in (transmitted to) the SVP. This must be performed to enter or change parameter values. Repeat steps 3 through 8 to set or change other parameter values within the same main item. 	<div data-bbox="975 248 1366 315" style="border: 1px solid black; padding: 5px;">SYSTEM CONFIG DATA LOADED!</div> <p>After 2 seconds:</p> <div data-bbox="975 405 1366 472" style="border: 1px solid black; padding: 5px;">SVP CONFIG SYSTEM CONFIG?</div>
8	Press the  and  keys in that order. This exits from configuration mode. This can be used to exit from configuration mode at any time.	<div data-bbox="975 651 1366 719" style="border: 1px solid black; padding: 5px;">SVP PCV-123 READY...</div>

~Note *Always perform steps 5, 6 and 7 (data confirmation and registration (transfer)) every time you set or change data. In particular, this is especially important when using step 8 to exit from configuration mode. Additionally, we recommend performing a forcible write operation after completing a configuration operation.*

Data can be verified even more reliably by printing it out. See “Data Printing” on page 48, for detailed information.

If an out of range value is entered

If a value that exceeds the allowable range for the setting, the following will be shown for 2 seconds in the lower line on the screen.

CTL CONFIG
EXCESS !!

The SFC will then return to the input screen.

If a communication error occurs during confirmed data registration (transfer)

If a communication error occurs during confirmed data registration (transfer), the following will be shown for 2 seconds in the lower line on the screen.

CTL CONFIG
NO CHANGES MODE



Then, the SFC will return to the following screen (main item selection).



SVP CONFIG
CTL CONFIG?

Repeat the registration (transfer) operation.

The SFC also uses the same display when a registration (transfer) operation is performed on data that has not been changed.

4-8: Starting and stopping configuration [SVP/SVT]

The flowchart for starting and terminating configuration, and for moving between items (A) through (H), is shown below. The  and  keys are used to move between items. See the following pages for detailed documentation on each item.

~Note Press  to move to the next item (for example, to move from item (A) to item (B)) and press  to move to the previous item (for example, to move from item (B) to item (A)).

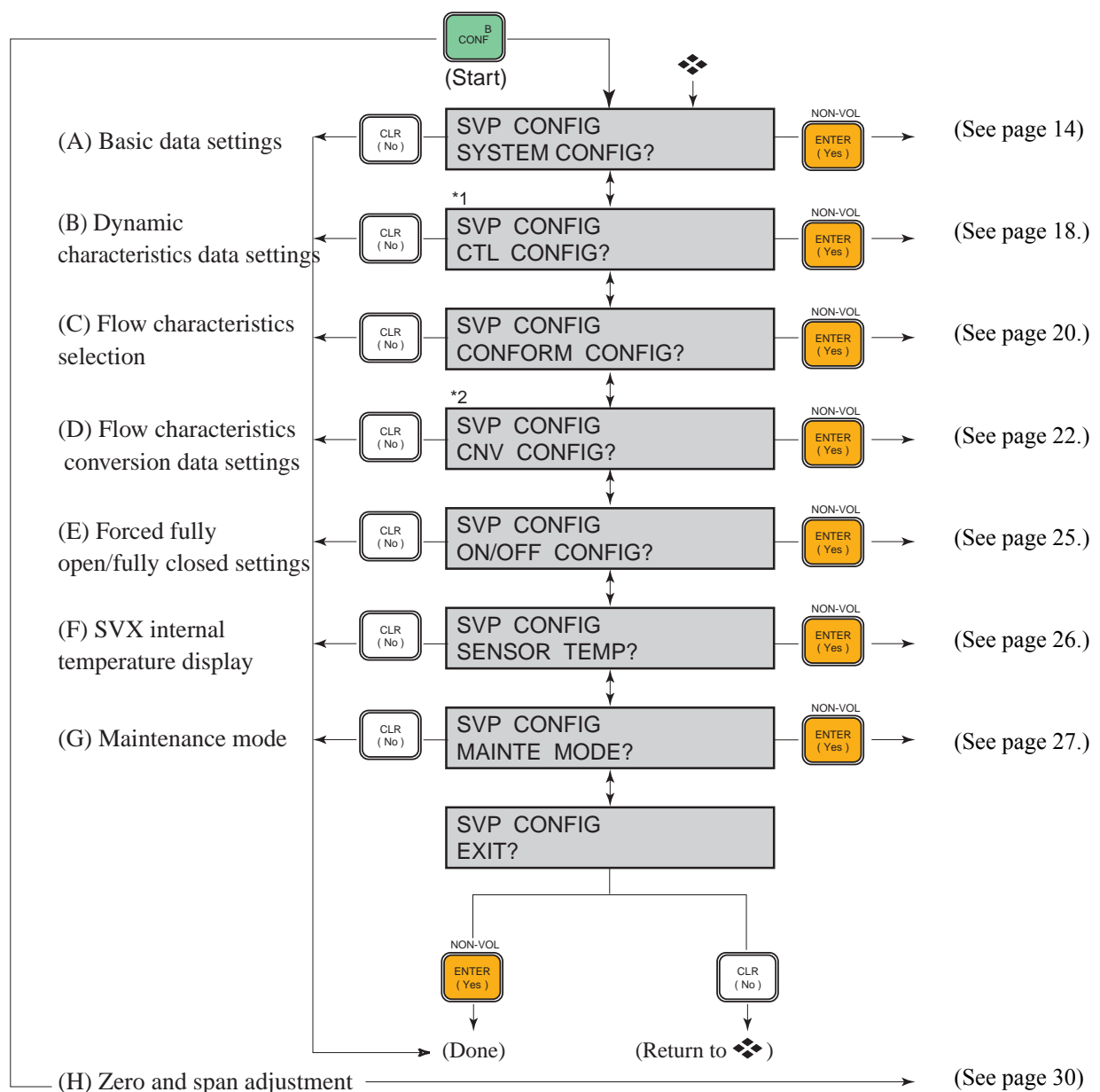





~Note *1. Only displayed when the ACTUATOR SIZE in the SYSTEM CONFIG is PARAM 0.
 *2. Only displayed when the CONFORM CONFIG is USER.

(A) Basic data settings (SYSTEM CONFIG)

This item, (A) Basic data settings (SYSTEM CONFIG), sets up the SVP control valve control system.

Flowchart for SYSTEM CONFIG

The flowchart for starting and terminating SYSTEM CONFIG, and for moving between items (1) through (7), is shown below. The  and  keys are used to move between items.

~Note Press  to move to the next item (for example, to move from item (1) to item (2)) and press  to move to the previous item (for example, to move from item (2) to item (1)).

(page 13)

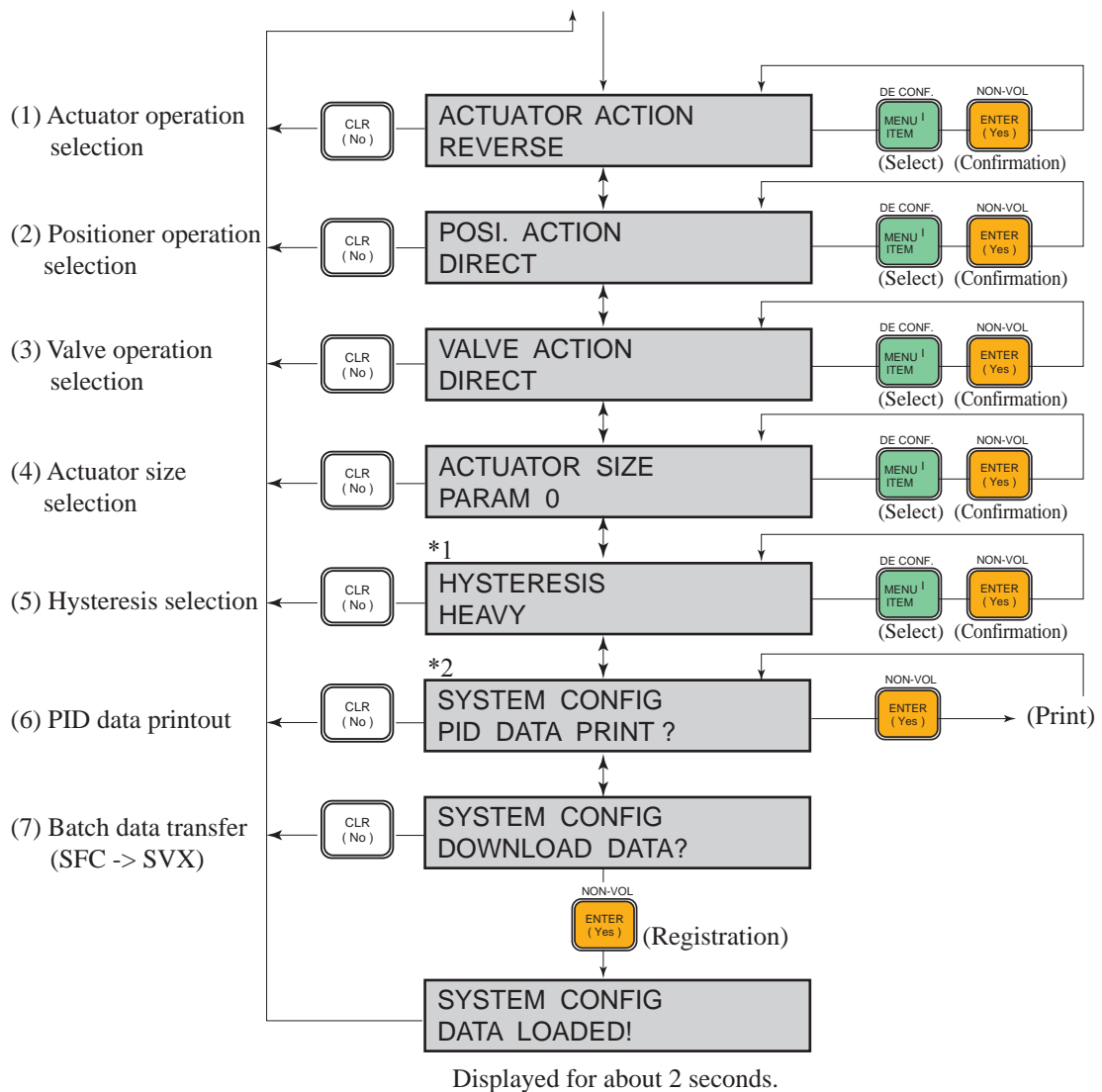

~Note *1. Not displayed when the actuator size is set to PARAM0.
 *2. Displayed when the actuator size is set to PARAM0.

(1) Actuator operation selection (ACTUATOR ACTION)

- Selects the operating direction of the actuator.
- Selects direct or reverse action (DIRECT/REVERSE). Specify direct operation (DIRECT) if the feedback lever is to move from higher to lower positions as the air pressure increases, or specify reverse operation (REVERSE) if the feedback lever is to move from lower to higher positions.

(2) Positioner operation selection (POSI. ACTION)

- Selects the operating direction of the positioner.
- Selects direct or reverse action (DIRECT/REVERSE). Specify direct operation (DIRECT) if the SVP output air pressure should go to zero if the power supply is disconnected, or specify reverse operation (REVERSE) if the SVP output air pressure should go to its maximum pressure.

The operating direction of the position is determined by the main unit hardware. The operating direction cannot be switched with this function. This item must be set to match the direction of the main unit specifications. Contact your Yamatake service representative to change the operating direction.

(3) Valve operation selection (VALVE ACTION)

- Selects the direction of the valve plug.
- Selects direct or reverse plug action (DIRECT/REVERSE). Specify direct operation (DIRECT) if the feedback lever is to move from higher to lower positions when the control valve moves in the open to closed direction, or specify reverse operation (REVERSE) if the feedback lever is to move from lower to higher positions. See “3-1: Auto-setup” on page 3-1., in this section for the method for making this selection.

(4) Actuator size selection (ACTUATOR SIZE)

- Selects the size of the actuator.
- Select one of parameter 0 to parameter 9 (PARAM0 to PARAM9).
- Refer to “Table 4-1: SVP PID parameter table” on the following page and select the parameter that matches the model of the actuator that is installed.

~Note *The parameter set here determines PID calculation parameters used to control the control valve (That is, the dynamic characteristics are determined by this setting.)
If parameter 0 (PARAM0) is selected, it will be possible (and necessary) to perform the settings described in (B) Setting the dynamic Characteristics Data. Normally, this setting is not used.*

(5) Hysteresis selection (HYSTERESIS)

- Selects the magnitude of the hysteresis difference due to friction in the control valve gland packing.
- Select one of heavy, medium, or light (HEAVY, MEDIUM, or LIGHT).
- Refer to “Table 4-2: Hysteresis parameter table” and select a parallel appropriate for the gland packing material.

~Note *The parameter set here determines PID calculation parameters used to control the control valve*

This setting is not required if parameter 0 (PARAM0) in item (4) Actuator Size Selection is selected.

The SVP PID parameter table (actuator correspondence table) consists of the items shown below.

Table 4-1: SVP PID parameter table

Actuator diaphragm capacity (cm ³)	Actuator model ⁱ	Parameter (PARAM)
1000	HA1, VA1, PSA1	1
3500	HA2, VA2, PSA2	2
7600	HA3, VA3, PSA3	3
14000	HA4, VA4, PSA4	4
25300	VA5	5
8400	VA6, PSA6	6
760	VR1	7
2200	VR2	8
5800	VR3	9
Values other than the above ⁱⁱ	-	0 ^{*ii}

Note) ^{*i.} *This is set according to the specifications and model number when shipped from the factory.*

Note) ^{*ii.} *Consult with your Yamatake service representative.*

Table 4-2: Hysteresis parameter table

Gland packing material example	Hysteresis (HYSTERESIS)
Graphite packing	Heavy (HEAVY)
Yarn packing	Medium (MEDIUM)
Type V PTFE packing	Light (LIGHT)

(6) PID data printout (PID DATA PRINT)

- Prints the SVP PID calculation parameters set in (B) Dynamic characteristics data settings (CTL CONFIG).

~Note *Printing is only possible when if parameter 0 (PARAM0) in item (4) Actuator size selection is selected.*

The GP, GI, and GD data are not printed when GE is 0.

If a model VR actuator is used with Param0, set the valve action (V Act) item to the opposite setting.



A size PARAM 0	
CONTROL DATA	
P	2.000
I	: 10.000
D	: 0.25
GE	: +/- 5.000%
GP	: 1.0000
GI	: 10.000
GD	: 0.2500



(B) Dynamic characteristics data settings (CTL CONFIG)

This item, (B) Dynamic characteristics data settings (CTL CONFIG), allows you to set the SVP dynamic characteristics data freely.

~Note It will be possible (and necessary) to perform these settings only if parameter 0 (PARAM0) is selected in the actuator size selection (ACTUATOR SIZE) item in the basic data settings.

Flowchart for CTL CONFIG

The flowchart for starting and terminating CTL CONFIG, and for moving between items (1) through (8), is shown below. The  and  keys are used to move between items.

~Note Press  to move to the next item (for example, to move from item (1) to item (2)) and press  to move to the previous item (for example, to move from item (2) to item (1)).

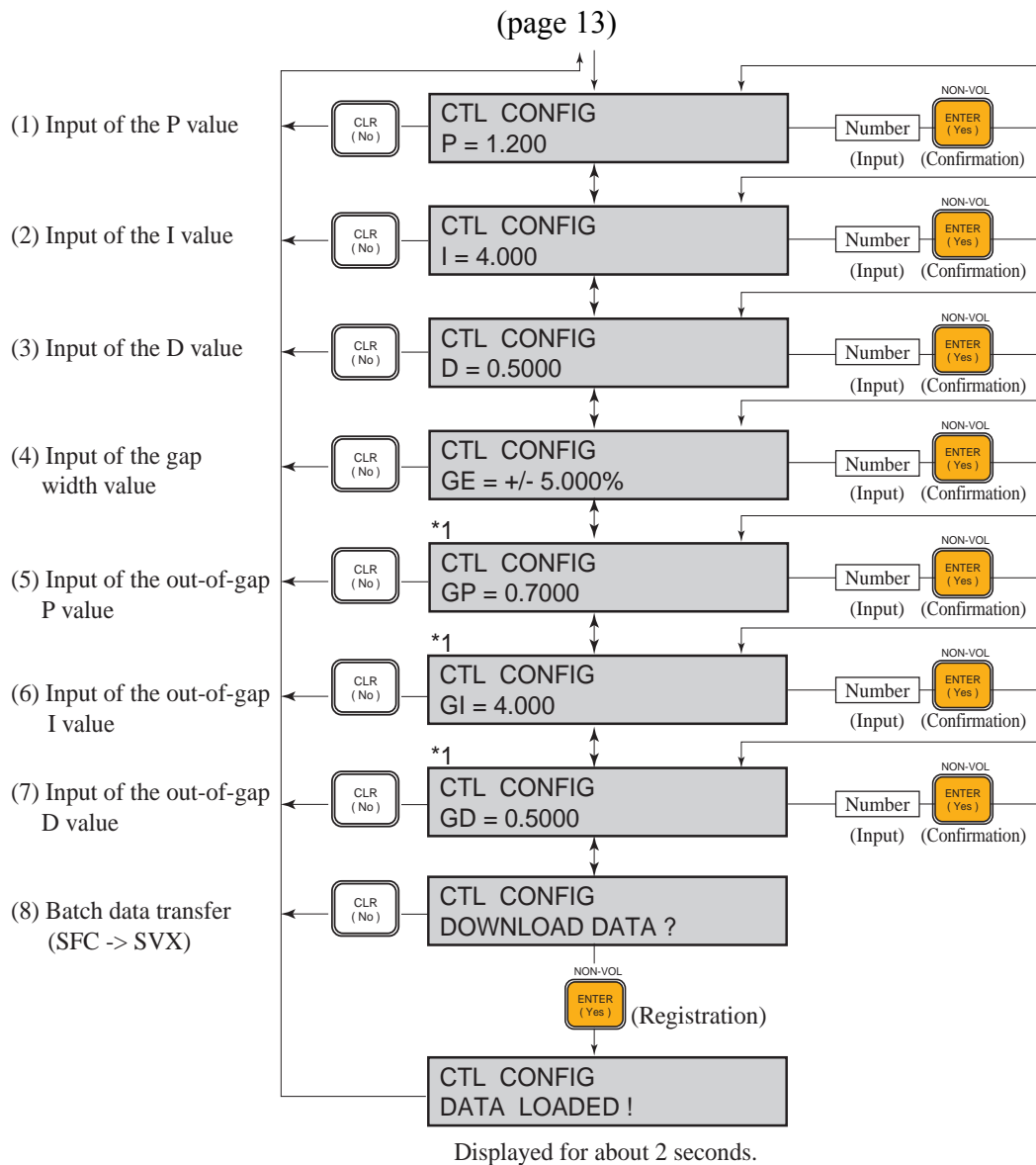

~Note *1. This is not displayed if GE is 0.

Gap-action type PID

The gap-action type PID method is adopted in the SVP to determine the dynamic characteristics.

In the gap-action type PID method, deviation values (the gap) above and below the target value are set up, and the PID parameters are changed depending on whether the process value is inside or outside the gap.

This method has the advantages that both rapid response characteristics and stability can be achieved with relatively simple tuning.

Parameter descriptions

The table below lists the parameters and their descriptions.

Parameter	Description	Units
P	Reciprocal of the in-gap proportional band	% ⁻¹
I	In-gap integrated time	S ⁻¹
D	In-gap differentiated time	S
GE	Gap width	%
GP	Reciprocal of the out-of-gap proportional band	% ⁻¹
GI	Out-of-gap integrated time	S ⁻¹
GD	Out-of-gap differentiated time	S

Example: When P is 2.000, this indicates that $2\%^{-1} = \frac{1}{0.02}\% = 50\%$. This means using 50% as the proportional band, as the term is commonly used.

~Note Values in the range -19999 to +19999 can be entered.



The GP, GI, and GD parameters cannot be set when GE is 0.



(C) Flow characteristics selection (CONFORM CONFIG)

This item, (C) Flow characteristics selection (CONFORM CONFIG), allows you to select the flow characteristics.

The user can also set arbitrary characteristics.

Flowchart for CONFORM CONFIG

The flowchart for starting and terminating CONFORM CONFIG, and for moving between items (1) and (2), is shown below. The  and  keys are used to move between items.

~Note Press  to move to the next item (for example, to move from item (1) to item (2)) and press  to move to the previous item (for example, to move from item (2) to item (1)).

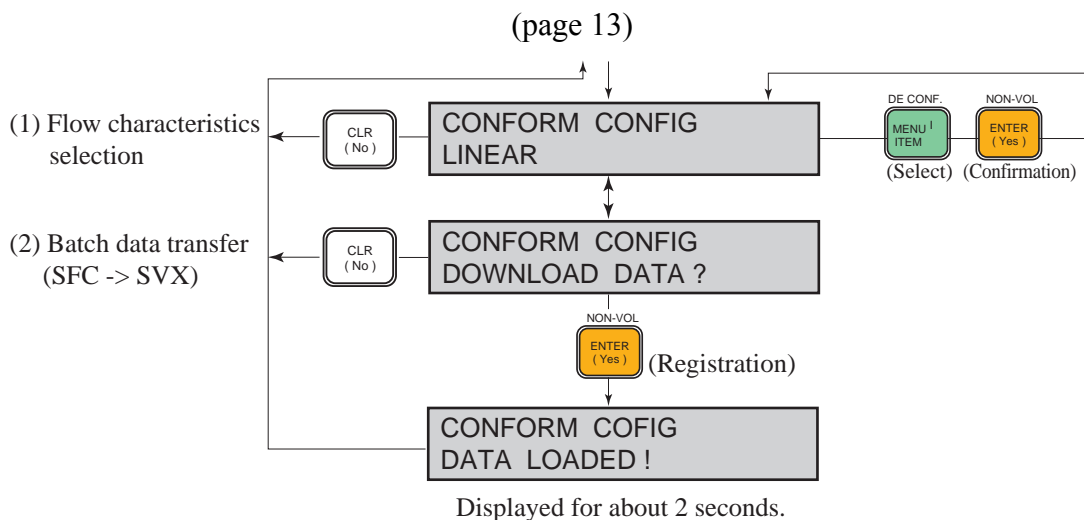

Types of flow characteristics

- One of linear, equal percent, quick open, and user (LINEAR, EQUAL%, QUICK OPEN, and USER) can be selected as the flow characteristics.
- The figure presents an overview of each of these characteristics.

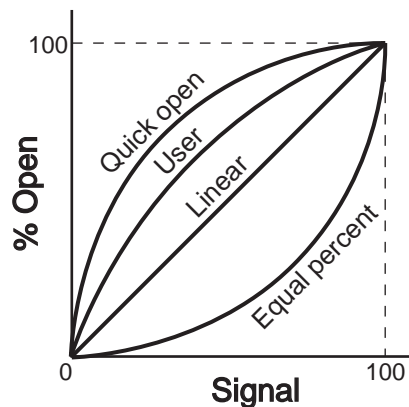

Figure 4-3 Flow characteristics overview

~Note *If user (USER) is selected, it will be possible (and necessary) to perform the settings described in (D) Flow characteristics conversion data settings (CNV CONFIG).*

When shipped from the factory, the user (USER) settings are set to data that corresponds to converting the valve characteristics of a pressure balance type control valve (model ADVB/ADVM) to linear.



(D) Flow characteristics conversion data settings (CNV CONFIG)



This item, (D) Flow characteristics conversion data settings (CNV CONFIG), allows you to set up converted data for arbitrary user flow characteristics.

The characteristics curve can be printed.

~Note *It will be possible (and necessary) to perform these settings only if user (USER) is selected in (C) Flow characteristics selection (CONFORM CONFIG).*

Flowchart for CNV CONFIG

The flowchart for starting and terminating CNV CONFIG, and for moving between items (1) through (3), is shown below. The  and  keys are used to move between items.

~Note Press  to move to the next item (for example, to move from item (1) to item (2)) and press  to move to the previous item (for example, to move from item (2) to item (1)).

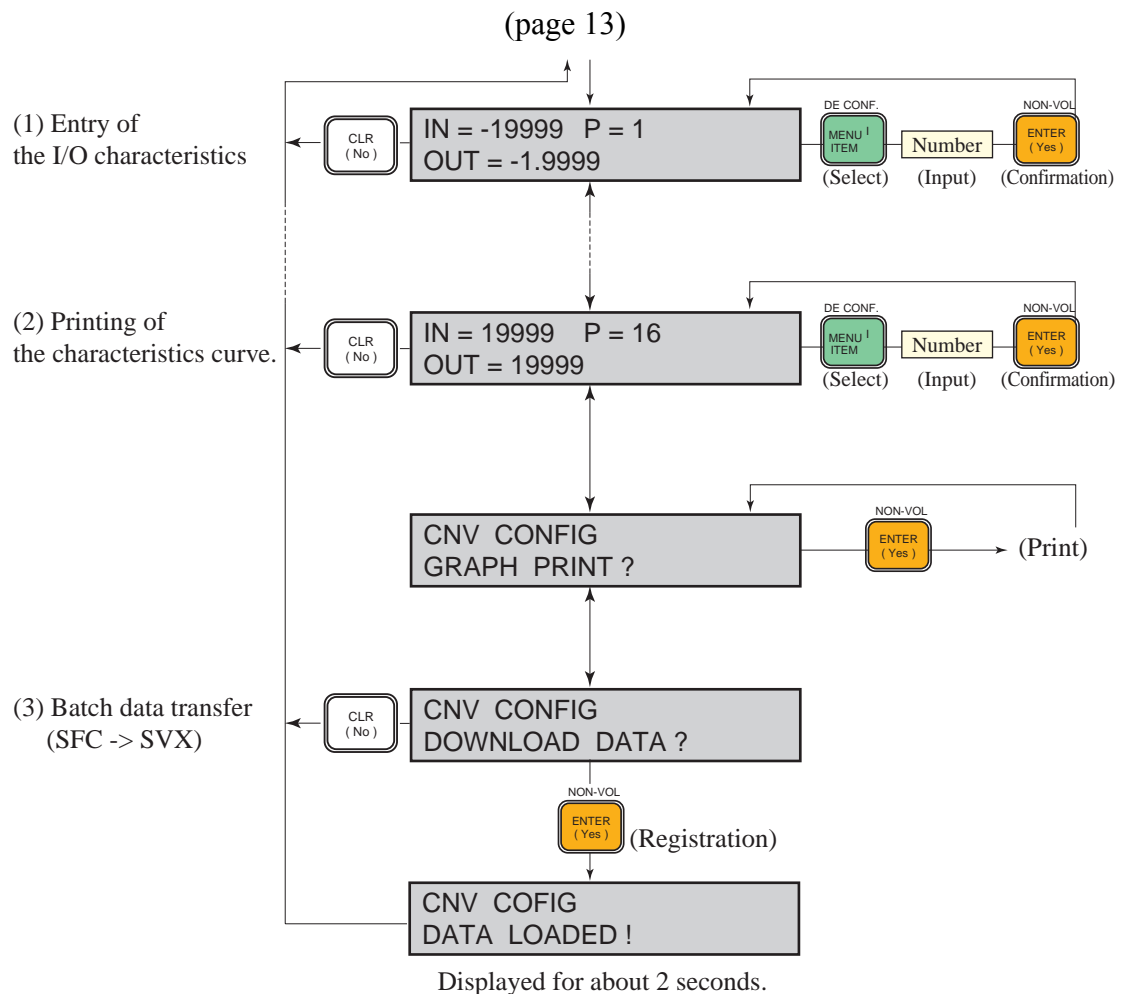

Flow characteristics conversion data

- There are 16 data points, corresponding to P = 1 to P = 16.
- For each point, both the input signal (IN%) and position (OUT%) are specified.
- The characteristics will consist of the line formed by linearly interpolating between adjacent points.

~Note All 16 points (input value and valve position) must be set.

The values P = 1 to P = 16 must be set in order of increasing input values, starting with the smallest value.

The values used must have the property of monotonic increasing.

Values in the range -19999 to +19999 can be entered.

Printing the characteristics curve

The following presents an example of printing the characteristics curve and the input data used.

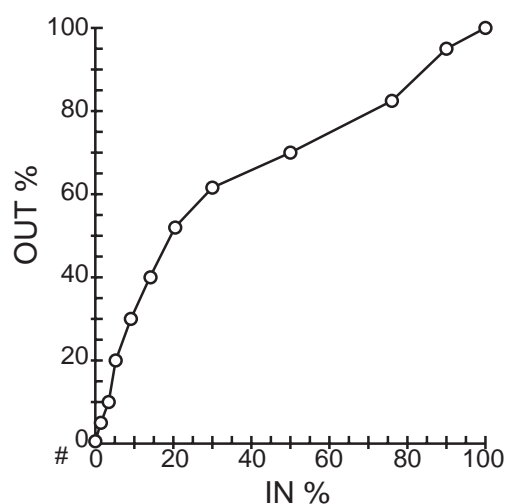

Figure 4-4

Point	SFC IN % ENTRY (Control signal input %)	SFC OUT % ENTRY (Valve travel %)
1	-19999	-19999
2	0.000	0.000
3	2.0	5.0
4	2.9	10.0
5	4.7	20.0
6	7.6	30.0
7	12.4	40.0
8	20.2	50.0
9	32.7	60.0
10	53.1	70.0
11	76.5	80.0
12	90.7	90.0
13	100.0	100.0
14	200.0	200.0
15	400.0	400.0
16	19999	19999

Examples

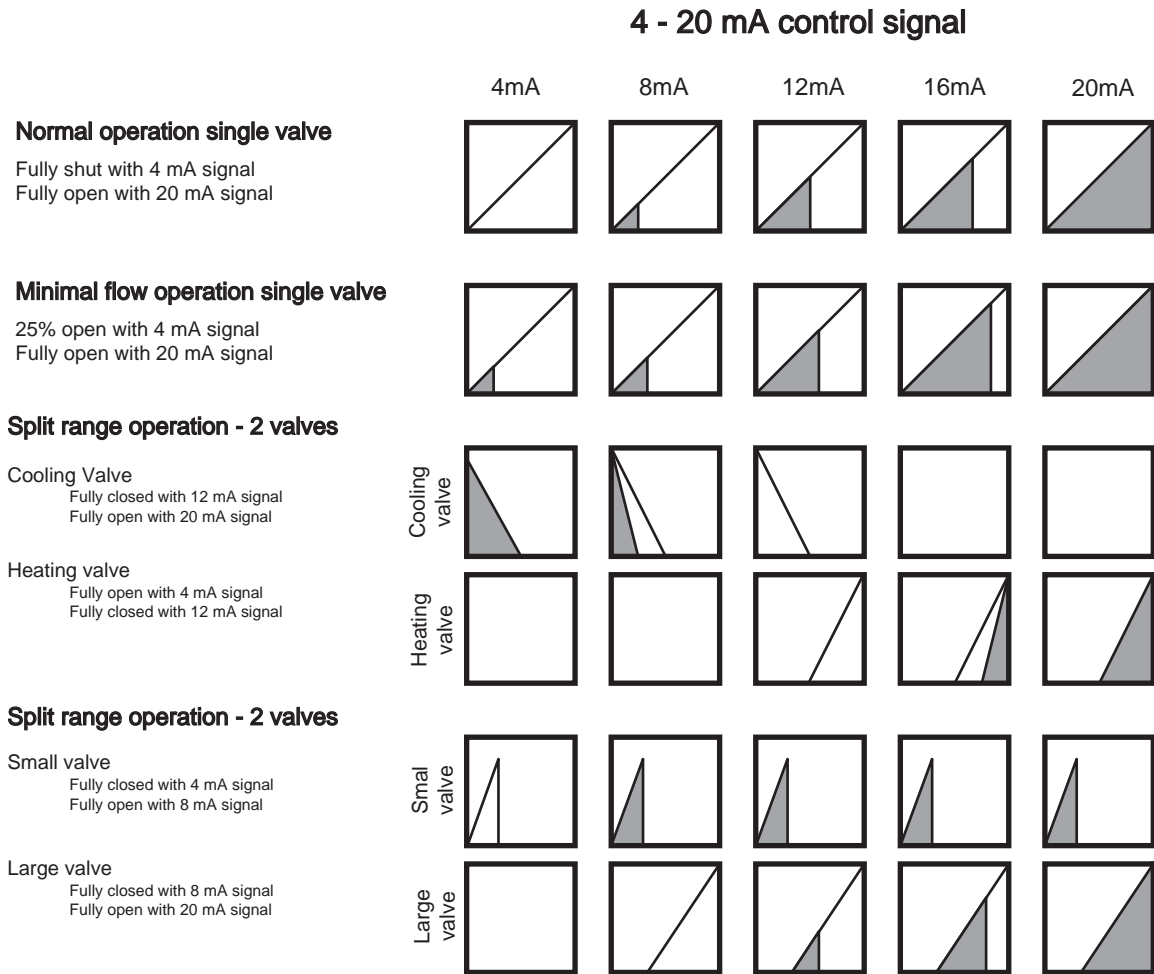

Figure 4-5

Flow Characteristics Examples

Normal Operation Single Valve

A single valve ranging from fully closed to fully open in a 4 to 20 mA signal.

Minimal Flow Operation Single Valve

A single valve might start at 25% open and range to fully open in a 4 to 20 mA signal (low fire burner application).

Split Range Operation - Hot + Cold Valves

Two valves might be used in heating-cooling applications where one valve (heating) is fully open at 4 mA and fully shut at 12 mA, while the other valve (cooling) is also fully shut at 12 mA and fully open at 20 mA. There might be a gap between the operation of the two valves or they might overlap.



Split Range Operations - Two Valves



A small valve might be fully shut at 4 mA and fully open at 8 mA, with a larger valve fully shut at 8 mA and fully open at 20 mA.

(E) Forced fully open and fully closed settings (ON/OFF CONFIG)

This item, (E) Forced fully open and fully closed settings (ON/OFF CONFIG), allows you to set the current input values (%) that forcibly fully open and fully close the valve.

Flowchart for ON/OFF CONFIG

The flowchart for starting and terminating ON/OFF CONFIG, and for moving between items (1) through (3), is shown below. The  and  keys are used to move between items.

~Note Press  to move to the next item (for example, to move from item (1) to item (2)) and press  to move to the previous item (for example, to move from item (2) to item (1)).

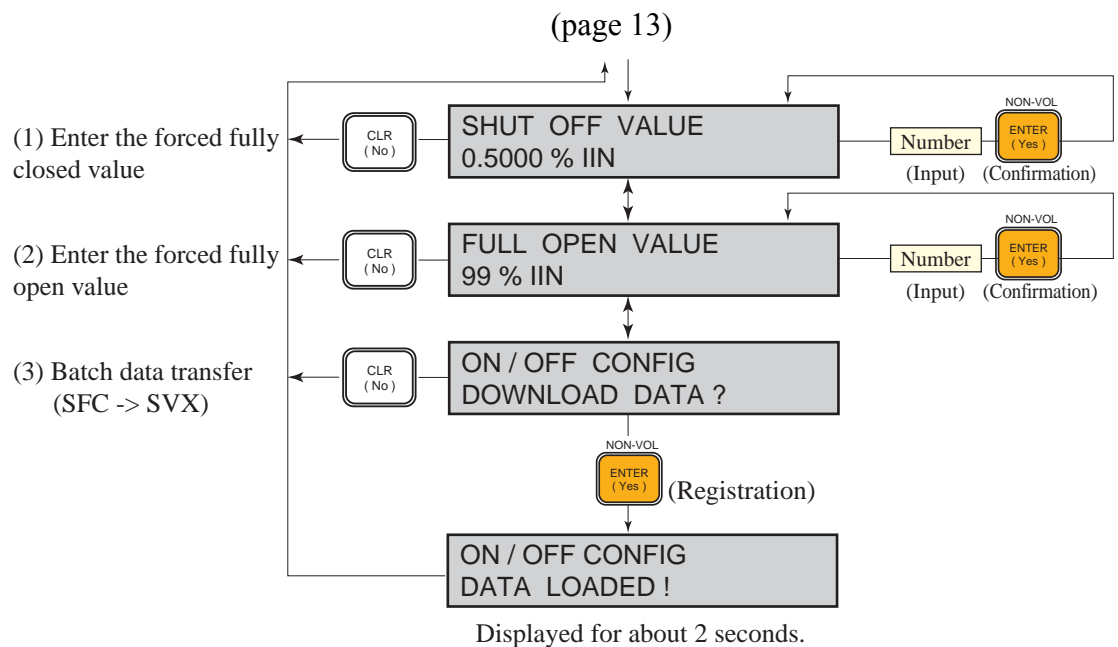

Forced fully open/fully closed settings

- The valve will be fully closed at input values less than the forced fully closed value, and it will be fully open at input values greater than the forced fully open value.
- The forced fully closed and forced fully open values can be set independently as percentages, IIN, of the current input value.
- The figure below presents an overview of the I/O characteristics when the forced fully closed and forced fully open values have been set.

~Note *These parameters must be set to values such that the forced fully open value (SHUT OFF VALUE) is strictly less than the forced fully open value (FULL OPEN VALUE).*

Values in the range -19999 to +19999 can be entered.

If the span setting is adjusted after an auto-setup operation, change the forced fully open value (FULL OPEN VALUE) to be 1% less than the overstroke percentage.

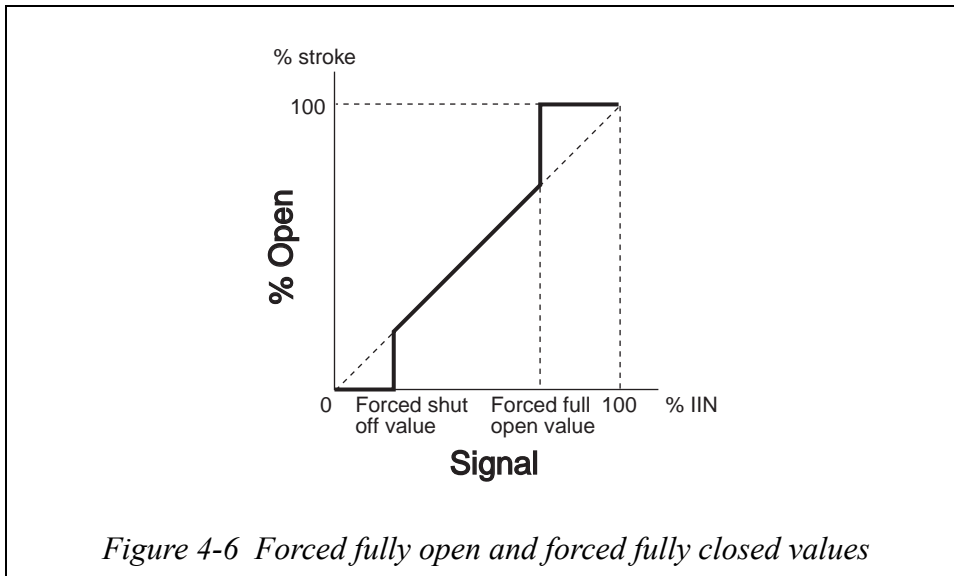
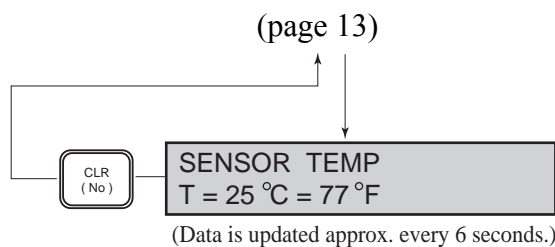

Figure 4-6 Forced fully open and forced fully closed values

(G) SVP internal temperature display

This item, (G) SVP internal temperature display, displays the SVP electronics board sensor ambient temperature in Celsius and Fahrenheit (°C and °F).



Flowchart for SENSOR TEMP





(H) Maintenance mode (MAINTE MODE)

This item, (H) Maintenance mode (MAINTE MODE), is used for maintenance of the SVP. It stores the auto setup and settings data.

Flowchart for MAINTE MODE

The flowchart for starting and terminating MAINTE MODE, and for moving between items (1) through (4), is shown below. The  and  keys are used to move between items.

~Note Press  to move to the next item (for example, to move from item (1) to item (2)) and press  to move to the previous item (for example, to move from item (2) to item (1)).

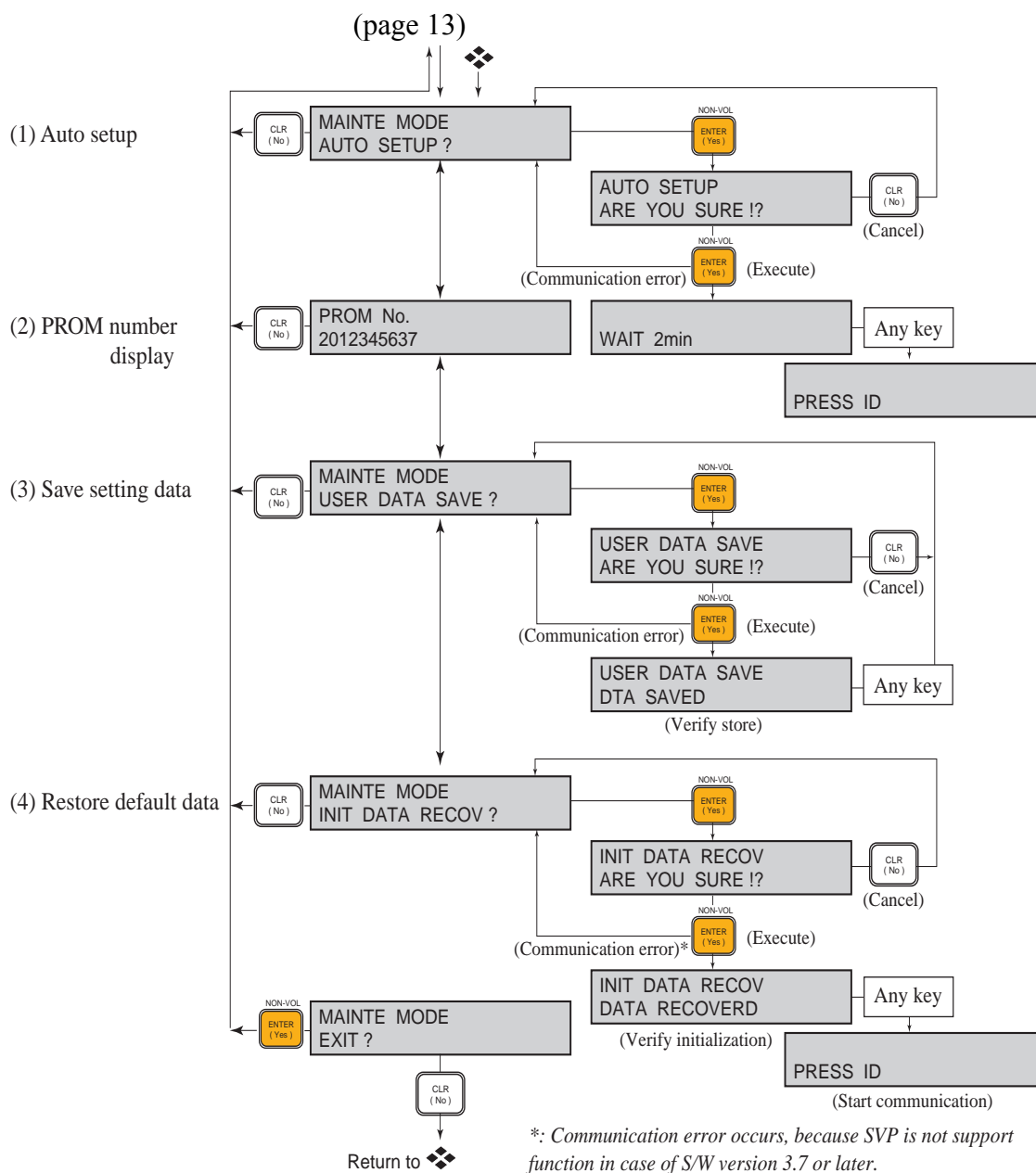

(1) Auto setup

The following auto setup items are performed.

- Zero and span adjustment
- Actuator direction setting
- Input signal LRV and URV setting
- Actuator size selection
- Hysteresis setting
- Position transmission burnout direction selection

WARNING

Performing the auto setup operation is dangerous because the valve moves rapidly from the fully closed position to the fully open position. Prepare yourself and the process in advance so that no one is injured and the process is not adversely affected when the valve operates.

~Note *When a model VR actuator is used, set the actuator size to one of PARAM7 to PARAM9 before performing an auto setup operation. (See “(A) Basic data settings (SYSTEM CONFIG)” on page 4-14.)*

Do not lower the input signal (4-20 mA) to a level less than 4 mA. (The level of the signal can be set to any level in the 4-20 mA range without problem.)

The operation has completed when after the actuator has followed the input signal and the system has returned to the control state.

After the operation completes, hold the input signal at a level above 4 mA for 30 seconds to write the settings.

There are cases where the dynamic characteristics may not be set correctly due to the size of the actuator (when the actuator is smaller than the Yamatake model HA1 actuator (diaphragm chamber capacity: 850 cm³)) or the operating stroke (when the stroke is less than 14.3 mm).

In these cases, refer to “(B) Dynamic characteristics data settings (CTL CONFIG)” on page 18, Setting the Dynamic Characteristics Data, and set the dynamic characteristics manually.

After the auto setup operation completes, vary the input signal manually and verify that the actuator moves to the corresponding position. If the span position is displaced, adjust the span.

(2) PROM number display (PROM NO.)

- This function displays the SVP internal PROM NO. (serial number).

(3) Save settings data (USER DATA SAVE)

- Saves all of the SVP internal data in place of the factory shipment data specifications (data set according to the model number).
- Use the “Recall Factory Data” operation to recall the saved data.
- We recommend saving the settings data after installing the SVP and after all settings have been completed.

~Note *All the factory shipment data is lost.*

When the data is written, the settings data is written to the SVP internal nonvolatile memory that is used for normal operation. This means that this data will not be lost even if the SVP power is turned off. This operation copies the contents of the memory used for normal operation to storage memory.

If a communications error occurs during communication (during storing), the data will not be stored. Repeat the store operation if this occurs.

(4) Restore default data (INIT DATA RECOV)

- This operation returns all the SVP internal data to the default (initial values) state.
- See the “Internal Data Default Values Table” for more information on default data (initial values).

~Note *Since use of this function will require that the SVP be adjusted and set up again, this function should not be used by anyone other than Yamatake service personnel.*





After recalling the data, start using the SVP from the starting communication step.













If a communication error occurs during communication (or during initialization), the initialization operation will not be performed. Perform the initialization operation again if this happens.

(I) Zero-span adjustment

Using SFC with input signal

Procedure for setting the valve fully closed position (zero)

Step	Operation	SFC screen
1	Apply the input current value (LRV: this will be 4.00 mA here) that corresponds to the valve fully closed position from the controller (constant-current supply).	—
2	Verify on the SFC screen that the system is in the SVP mode operation wait state. The mode is displayed at the upper left of the screen.	SVP PCV-123 READY...
3	Press  . <ul style="list-style-type: none"> The set current value (this will be 4.00 mA here) for the valve fully closed position will be displayed on the screen. 	LRV PCV-123 SHUT 4.00 mA
4	Press  . <ul style="list-style-type: none"> The display of the set current value for the valve fully closed position will be cleared from the screen. 	LRV PCV-123 SHUT
5	Press  . <ul style="list-style-type: none"> The adjustment value (the change in the angle of the feedback lever) will be displayed at the lower right of the screen. Press  to change this value. Each time this button is pressed, the value will change as shown below. <p>→0.006°→ 0.03°→0.3°→ 3 °→ 30°</p>	CORRECT LRV INC / DEC 0.006°

Step	Operation	SFC screen
6	<p>Adjust the valve fully closed position by pressing  and .</p> <p>Press  to move the valve in the direction of opening further. (Note that this is reversed for VR model actuators.)</p> <p>Press  to move the valve in the direction of closing further. (Note that this is reversed for VR model actuators.)</p> <p>Each time the  or  is pressed, the angle will change by the amount set in step 5</p> <p>The adjustment value can be changed by pressing .</p>	<div data-bbox="1066 241 1460 315" style="border: 1px solid black; padding: 5px;">CORRECT LRV WORKING...</div> <p>~Note <i>The fully closed position adjustment technique shown here cannot be used if the forced closed function is operating. First refer to “(E) Forced fully open and fully closed settings (ON/OFF CONFIG)” on page 25, Forced Fully Open and Fully Closed Values, and set the forced fully closed value to less than 0%, and then perform the fully closed position adjustment.</i></p>
7	<p>Verify that the valve has reached the fully closed position, and press  twice.</p> <p>Only press  after completing the adjustment.</p> <p>The first time  is pressed, the SFC returns to the screen of step 4.</p>	<div data-bbox="1066 990 1460 1064" style="border: 1px solid black; padding: 5px;">SVP PCV-123 READY...</div>
8	<p>Press .</p>	<div data-bbox="1066 1406 1460 1480" style="border: 1px solid black; padding: 5px;">SHIFT-</div>
9	<p>Press .</p> <p>The setting data is written forcibly. After displaying the screen shown at the right, the SFC returns to the operation wait state.</p>	<div data-bbox="1066 1550 1460 1624" style="border: 1px solid black; padding: 5px;">SVP PCV-123 DATA NONVOLATILE</div>

~Note *After complete through <step 7> in the above procedure, if the input from the constant-current supply is held steady for at least 30 seconds, the set and modified data will be stored automatically. However, we recommend performing <step 8> and <step 9> manually to be sure that the data is written.*

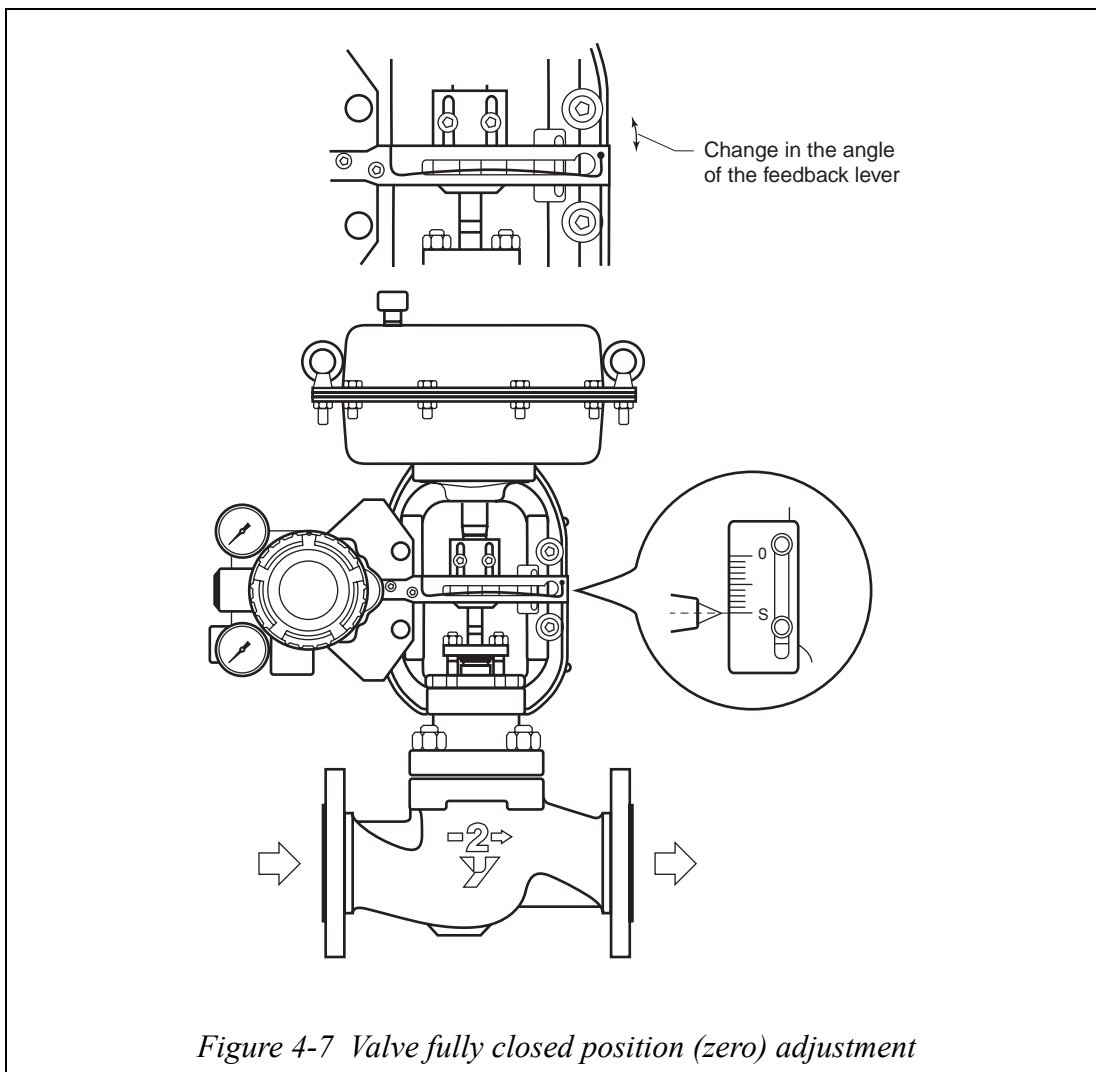

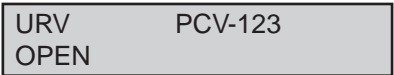









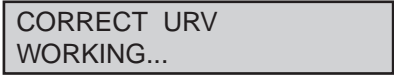



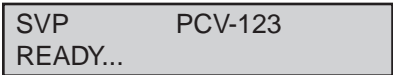





Figure 4-7 Valve fully closed position (zero) adjustment

Procedure for setting the valve fully opened position (span)

Step	Operation	SFC screen
1	Apply the input current value (URV: this will be 20.00 mA here) that corresponds to the valve fully opened position from the controller (constant-current supply).	—
2	Verify on the SFC screen that the system is in the SVP mode operation wait state. The mode is displayed at the upper left of the screen.	<div style="border: 1px solid black; padding: 5px; width: fit-content;"> SVP PCV-123 READY... </div>
3	Press  . <ul style="list-style-type: none"> The set current value (this will be 20.00mA here) for the valve fully opened position will be displayed on the screen. 	<div style="border: 1px solid black; padding: 5px; width: fit-content;"> URV PCV-123 OPEN 20.00mA </div>

Step	Operation	SFC screen
4	<p>Press  .</p> <ul style="list-style-type: none"> The display of the set current value for the valve fully opened position will be cleared from the screen. 	
5	<p>Press  .</p> <ul style="list-style-type: none"> The adjustment value (the change in the angle of the feedback lever) will be displayed at the lower right of the screen. Press  to change this value. Each time this button is pressed, the value will change as shown below. <p>➤0.006°➤0.03°➤0.3°➤3 °➤30°</p>	
6	<p>Adjust the valve fully opened position by pressing  and  .</p> <p>Press  to move the valve in the direction of opening further. (Note that this is reversed for VR model actuators.)</p> <p>Press  to move the valve in the direction of closing further. (Note that this is reversed for VR model actuators.)</p> <p>Each time the  or  is pressed, the angle will change by the amount set in step 5</p> <p>The adjustment value can be changed by pressing  .</p>	

Step	Operation	SFC screen
7	<p>Verify that the valve has reached the fully closed position, and press  twice.</p> <p>Only press  after completing the adjustment.</p> <p>The first time  is pressed, the SFC returns to the screen of step 4.</p>	
8	<p>Press .</p>	
9	<p>Press .</p> <ul style="list-style-type: none"> • The setting data is written forcibly. • After displaying the screen shown at the right, the SFC returns to the operation wait state. 	

~Note After complete through <step 7> in the above procedure, if the input from the constant-current supply is held steady for at least 30 seconds, the set and modified data will be stored automatically. However, we recommend performing <step 8> and <step 9> manually to be sure that the data is written.

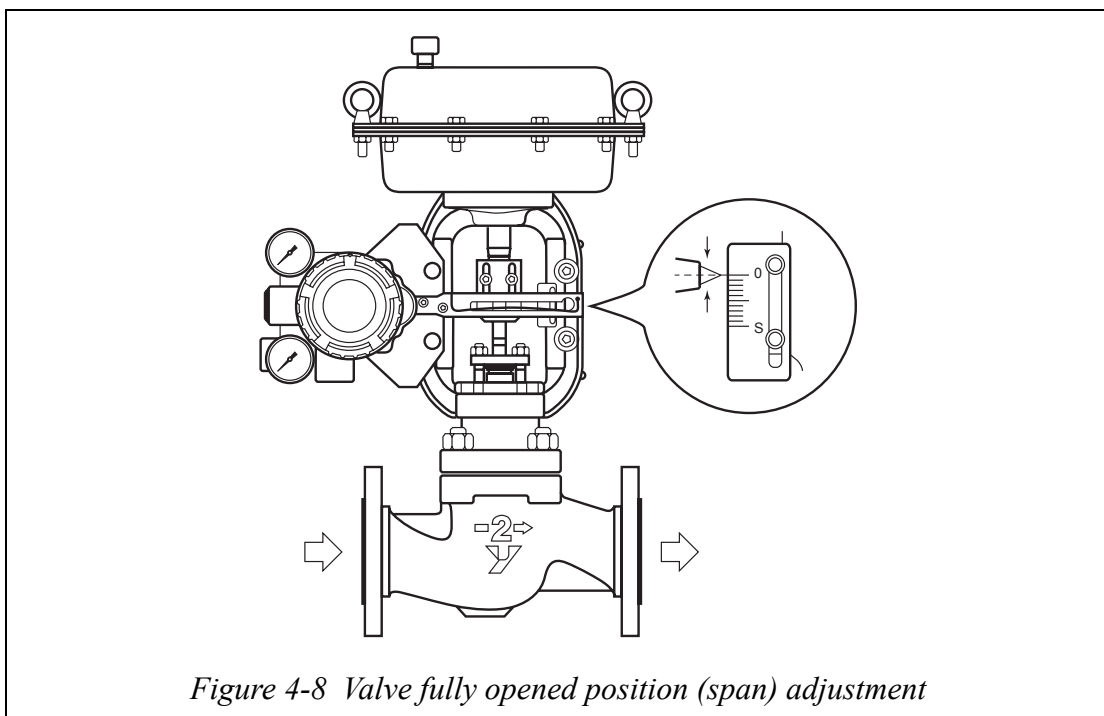

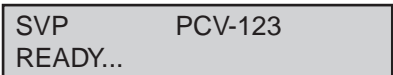

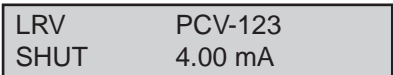

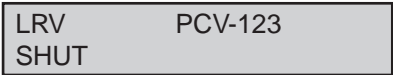

Figure 4-8 Valve fully opened position (span) adjustment





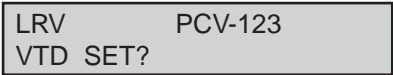

Using SFC with supply air

This adjustment technique holds the input signal fixed and manipulates the pressure reducing valve in the manual operating mode.

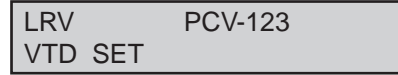
- ~Note *The following two operations must be performed after using this procedure.*
1. *Manually reset the pressure reducing valve to the original air supply pressure.*
 2. *Return the Auto/Manual switch to the automatic operation state.*

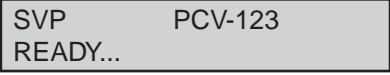
Procedure for setting the valve fully closed position (zero)





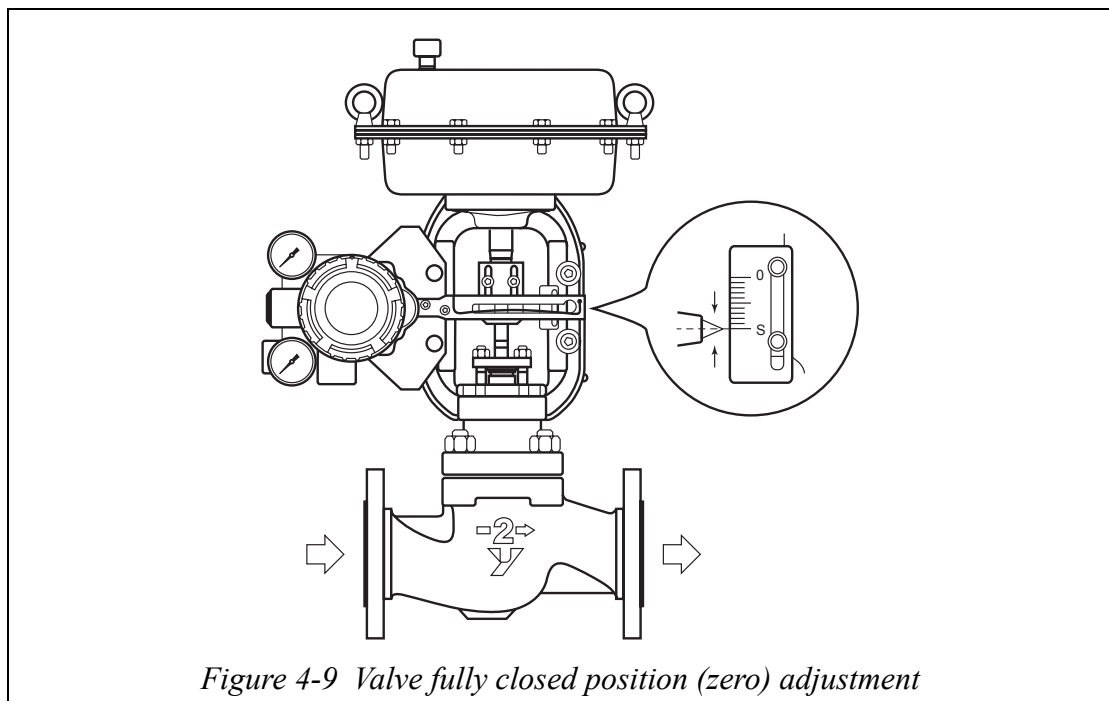

Step	Operation	SFC screen
1	Apply a current with an arbitrary value in the 4-20 mA range to the input from the controller (constant-current supply).	_____
2	Set the unit to manual operating mode with the Auto/Manual switch. (See “6-1: Auto/Manual selection switch” on page 6-1.)	_____
3	Adjust the air supply pressure so that the valve is in the fully closed position using the pressure reducing valve.	_____
4	Verify on the SFC screen that the system is in the SVP mode operation wait state. <ul style="list-style-type: none"> The mode is displayed at the upper left of the screen. 	
5	Press  . <ul style="list-style-type: none"> The set current value (this will be 4.00 mA here) for the valve fully closed position will be displayed on the screen. 	
6	Press  . <ul style="list-style-type: none"> The display of the set current value for the valve fully closed position will be cleared from the screen. 	
7	Verify that the valve is in the fully closed position and press  . <ul style="list-style-type: none"> If the valve has not reached the fully closed position, readjust the position with the pressure reducing valve. 	





Step	Operation	SFC screen
8	Press  . • The fully closed position of the valve has been set. • After the screen at the right is displayed, the display will return to the step 6 screen.	
9	Press  .	
10	Press  .	
11	Press  . The setting data is written forcibly.	
12	Return the Auto/Manual switch to the automatic operation state and lock it in place.	_____
13	Adjust the pressure reducing valve to the original air pressure supplied.	_____

~Note After complete through <step 7> in the above procedure, if the input from the constant-current supply is held steady for at least 30 seconds, the set and modified data will be stored automatically. However, we recommend performing <step 8> and <step 9> manually to be sure that the data is written.



Procedure for setting the valve fully opened position (span)

Step	Operation	SFC screen
1	Apply a current with an arbitrary value in the 4-20 mA range to the input from the controller (constant-current supply).	_____
2	Set the unit to manual operating mode with the auto/manual switch. (See “6-1: Auto/Manual selection switch” on page 6-1.)	_____
3	Adjust the air supply pressure so that the valve is in the fully opened position using the pressure reducing valve.	_____
4	Verify on the SFC screen that the system is in the SVP mode operation wait state. <ul style="list-style-type: none"> The mode is displayed at the upper left of the screen. 	<div style="border: 1px solid black; padding: 5px; display: inline-block;"> SVP PCV-123 READY... </div>
5	 Press  . <ul style="list-style-type: none"> The set current value (this will be 20.00 mA here) for the valve fully opened position will be displayed on the screen. 	<div style="border: 1px solid black; padding: 5px; display: inline-block;"> URV PCV-123 OPEN 20.00mA </div>
6	 Press  . <ul style="list-style-type: none"> The display of the set current value for the valve fully opened position will be cleared from the screen. 	<div style="border: 1px solid black; padding: 5px; display: inline-block;"> URV PCV-123 OPEN </div>
7	Verify that the valve is in the fully opened position and press  . <ul style="list-style-type: none"> If the valve has not reached the fully opened position, readjust the position with the pressure reducing valve. 	<div style="border: 1px solid black; padding: 5px; display: inline-block;"> URV PCV-123 VTD SET? </div>
8	 Press  . <ul style="list-style-type: none"> The fully closed position of the valve has been set. After the screen at the right is displayed, the display will return to the step 6 screen. 	<div style="border: 1px solid black; padding: 5px; display: inline-block;"> URV PCV-123 VTD SET </div>

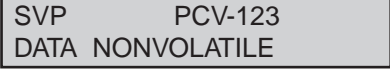
Step	Operation	SFC screen
9	Press  .	
10	Press  .	
11	Press  . The setting data is written forcibly.	
12	Return the auto/manual switch to the automatic operation state and lock it in place.	_____
13	Adjust the pressure reducing valve to the original air pressure supplied.	_____

~Note After complete through <step 9> in the above procedure, if the input from the constant-current supply is held steady for at least 30 seconds, the set and modified data will be stored automatically. However, we recommend performing <step 10> and <step 11> manually to be sure that the data is written.

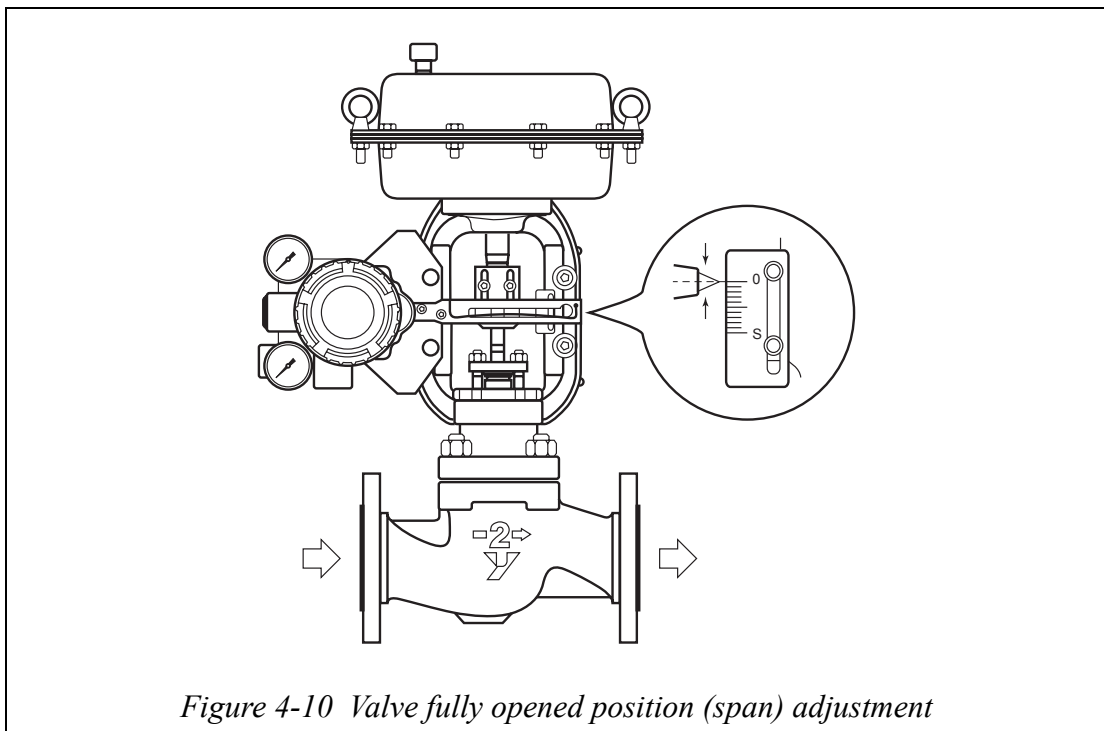

4-9: Setting and adjusting the current input range [SVP/SVT]









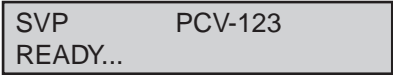

- This operation sets the current input range. The input can be set in the 4-20 mA range.
- A split range can also be set up easily.

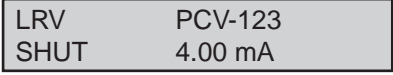
~Note Set the current input span to be 4 to 16 mA. If the span is less than 8 mA, the precision will be 1.5% of full scale.

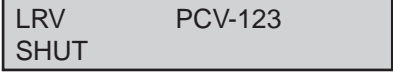
Procedure for setting up an arbitrary current input value

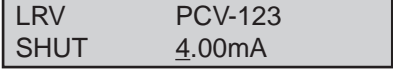
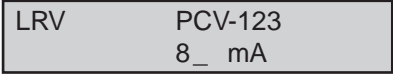
The procedure for setting up an arbitrary current input value is shown below.

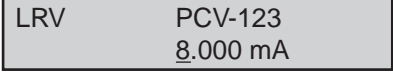
- For the valve fully closed position.











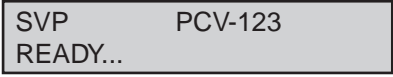

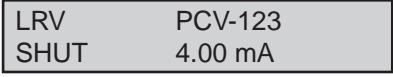
Step	Operation	SFC screen
1	Verify that the SFC is in the SVP mode command wait state. <ul style="list-style-type: none"> • The mode is displayed at the upper left of the screen. 	
2	Press  .	
3	Press  .	
4	Press  . <ul style="list-style-type: none"> • The SFC will display only the current value. • The cursor will be displayed. 	
5	Use the number keys to enter the current input value that corresponds to the valve fully closed position.	
6	Press  . <ul style="list-style-type: none"> • The data is now set. 	
7	Press  .	

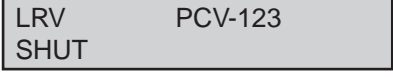
- For the valve fully opened position.

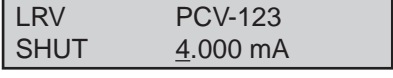
Step	Operation	SFC screen
1	Verify that the SFC is in the SVP mode command wait state. <ul style="list-style-type: none"> • The mode is displayed at the upper left of the screen. 	
2	Press .	
3	Press .	
4	Press . <ul style="list-style-type: none"> • The SFC will display only the current value. • The cursor will be displayed. 	
5	Use the number keys to enter the current input value that corresponds to the valve fully closed position.	
6	Press . <ul style="list-style-type: none"> • The data is now set. 	
7	Press .	

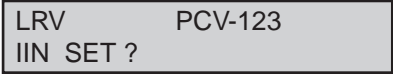
Procedure for setting up an actual current input value

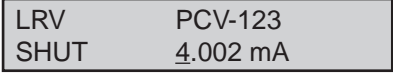
- For the valve fully closed position.

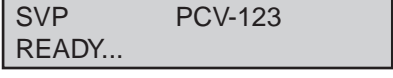
Step	Operation	SFC screen
1	Verify that the SFC is in the SVP mode command wait state. <ul style="list-style-type: none"> • The mode is displayed at the upper left of the screen. 	
2	Press  .	
3	Press  .	
4	Press  . <ul style="list-style-type: none"> • The SFC will display only the current value. • The cursor will be displayed. 	
5	Press  . <ul style="list-style-type: none"> • Verify that the actual input (the controller output) is at the value (mA) that you want to set before performing this step. 	
6	Press  . <ul style="list-style-type: none"> • The data is now set. • After displaying IIN set (IIN SET), the set value will be displayed. 	
7	Press  .	

- For the valve fully opened position.









Step	Operation	SFC screen
1	Verify that the SFC is in the SVP mode command wait state. <ul style="list-style-type: none"> • The mode is displayed at the upper left of the screen. 	
2	Press .	
3	Press .	
4	Press . <ul style="list-style-type: none"> • The SFC will display only the current value. • The cursor will be displayed. 	
5	Press . <ul style="list-style-type: none"> • Verify that the actual input (the controller output) is at the value (mA) that you want to set before performing this step. 	
6	Press . <ul style="list-style-type: none"> • The data is now set. • After displaying IIN set (IIN SET), the set value will be displayed. 	
7	Press .	

4-10:IIN/VTD simultaneous ranging [SVP/SVT]

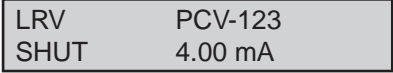

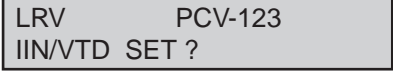

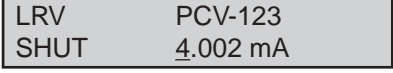

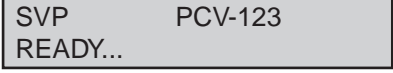

It is also possible, using this procedure, to set the current input range and to adjust the zero and span at the same time.

Procedure for setting the current input value and position

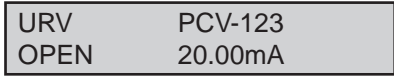
- For the valve fully closed position.

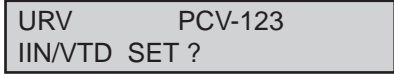
Step	Operation	SFC screen
1	Verify that the SFC is in the SVP mode command wait state. <ul style="list-style-type: none"> • The mode is displayed at the upper left of the screen. 	
2	Press  .	
3	Press  . <ul style="list-style-type: none"> • Verify that the actual input (the controller output) is at the value (mA) that you want to set before performing this step. 	
4	Press  . <ul style="list-style-type: none"> • The data is now set. • After displaying IIN/VTD set (IIN/VTD SET), the set value will be displayed. 	
5	Press  .	

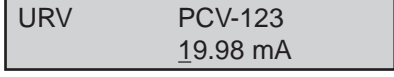

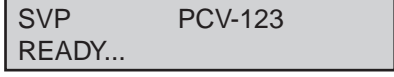



- For setting the current input value and position that correspond to the valve fully open position.

Step	Operation	SFC screen
1	Verify that the SFC is in the SVP mode command wait state. <ul style="list-style-type: none"> • The mode is displayed at the upper left of the screen. 	
2	Press  .	
3	Press  . <ul style="list-style-type: none"> • Verify that the actual input (the controller output) is at the value (mA) that you want to set before performing this step. 	
4	Press  . <ul style="list-style-type: none"> • The data is now set. • after displaying IIN/VTD set (IIN/VTD SET), the set value will be displayed. 	
5	Press  .	

4-11: Verifying operating data

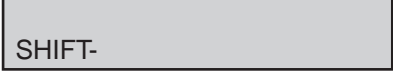

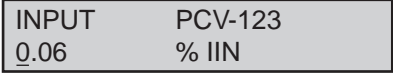

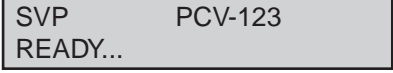
Verifying the current input value [SVP]

Verify the current input value to the positioner using the following procedure.

Step	Operation	SFC screen
1	Verify that the SFC is in the SVP mode command wait state. <ul style="list-style-type: none"> The mode is displayed at the upper left of the screen. 	 SFC screen showing SVP mode: SVP PCV-123 READY...
2	Press  .	 SFC screen showing SHIFT- mode: SHIFT-
3	Press  . <ul style="list-style-type: none"> The current input value will be displayed as a percentage and in mA alternately for about 6 seconds each. 	 SFC screen showing INPUT mode: INPUT PCV-123 0.06 % IIN After 6 seconds:  SFC screen showing INPUT mode: INPUT PCV-123 4.01 mA
4	Press  .	 SFC screen showing SVP mode: SVP PCV-123 READY...



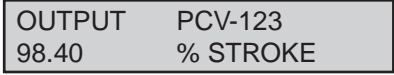

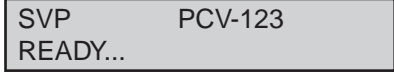

Verifying the position [SVP]

The procedure for verifying the position is given below.

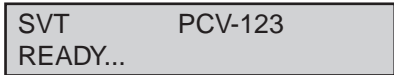
Step	Operation	SFC screen
1	Verify that the SFC is in the SVP mode command wait state. <ul style="list-style-type: none"> The mode is displayed at the upper left of the screen. 	
2	Press  . <ul style="list-style-type: none"> The position is shown as a percentage of the stroke. The display is updated every 6 seconds. 	
3	Press  .	

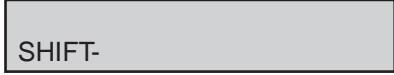
Verifying the EPM (Electro-Pneumatic converter Module) drive signals [SVT]

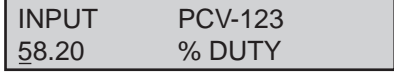

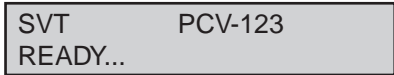

Use the following procedure for verifying the EPM (Electro-Pneumatic converter Module) drive signals.

Step	Operation	SFC screen
1	Verify that the SFC is in the SVT mode command wait state. <ul style="list-style-type: none"> The mode is displayed at the upper left of the screen. 	
2	Press  .	
3	Press  . <ul style="list-style-type: none"> The EPM drive signal is displayed as a duty percentage. 	
4	Press  .	

~Note This procedure is used when starting up operation of the SVP.

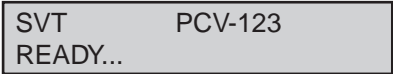

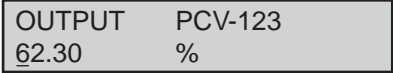
Verifying the position transmission output value [SVT]

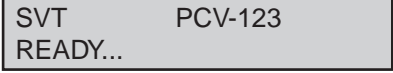
Use the following procedure to verify the position transmission output value.

Step	Operation	SFC screen
1	Verify that the SFC is in the SVT mode command wait state. <ul style="list-style-type: none"> The mode is displayed at the upper left of the screen. 	
3	Press  . <ul style="list-style-type: none"> The position transmission output value will be displayed as a percentage of the 4-20 mA range. 	
4	Press  .	

Self diagnostics [SVP/SVT]

The SVP includes a self diagnostics function. This function is convenient for troubleshooting.

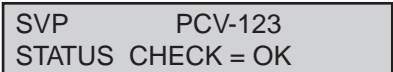
Step	Operation	SFC screen
1	Verify that the SFC is in the SVT mode command wait state.	
2	Press  . <ul style="list-style-type: none"> The results of the self diagnostics are displayed. See “Chapter5: Configuration using a HART Communicator”, SFC message documentation, for the meaning of the displayed message. 	

4-12: Data Printing

Printing function overview

It is important to verify the internal settings and the responses from the SVP to assure correct operation, both when starting SVP operation and during operation. At these times, it is convenient to use the SFC with a printer to communicate with the SVP and print out the data. The SFC with an attached printer provides the two printing functions described below.



Printing functions

- Configuration printing (data printing):
This function prints out the SVP tag number (TAG NO.) and other internal data on the SFC printer.
- Action printing (continuous printout):
This function prints out the responses of the SVP to SFC key operations continuously.

Printer

The optional SFC printer is a 24 characters per line thermal printer. When the SFC power is turned on, the printer automatically moves the head back and forth once and then stops. The paper is advanced about 5 mm at this time.

Paper feed

Press  +  to advance the paper. "PRINTER FEED" will be displayed on the screen, and the paper will be advanced one line. While this is still displayed,

pressing  will advance the paper 1 line.

Press  to cancel the feed function.

Replacing the paperroll





When the paper is used up, replace the paper roll in the paper roll chamber. See the SFC user's manual (CM2-SFC100-2001) for details on the procedure for replacing the paper.

Configuration Printout (Verifying all data at once) [SVP/SVT]

All internal data can be printed out for verification using this function.

Procedure

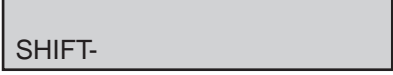
The procedure for printing all internal data of SVP is shown below.

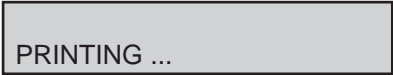
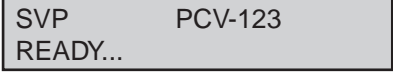
Step	Operation	SFC screen
1	Verify that the SFC is in the command wait state. <ul style="list-style-type: none"> If the screen at the right is not displayed, press [CLR]. 	
2	Press  .	
3	Press  .	
4	The SVP will return to the command wait state when the printing has completed.	

~Note Press  to cancel printing. Printing will stop and the paper will be advanced by two lines.

Configuration printout example

To get a printed summary of the internal SVP settings and parameters, from the Ready

State, press  +  (SFC with printer attachment only).

An example of this printout is shown below.

'94-12-03 14:30	Date / hour
TAG NO. PCV-0123	Tag number
PROM# : 2012345637	Serial number
SW VER : 1.0	Software version
ANA/DE : ANALOG XMTR	Output format
F/SAFE : DOWNSCALE	Burnout direction (position transmission)
SV : T= 17 °C(64 °F)	Inside sensor temperature
FORM : USER	Flow characteristic
A ACT : REVERSE	Actuator action
P ACT : DIRECT	Positioner action
V ACT : DIRECT	Valve action
A SIZE : PARAM 0	Actuator size
*1 HYST : HEAVY	Hysteresis (gland packing)
LRV : 4.000 mA	Lower limit of input range (input value for shut off valve)
URV : 20.00 mA	Upper limit of input range (input valve for full open valve)
*2 P : 1.200	P
*2 I : 4.000	I
*2 D : 0.5000	D
*2 GE : +/-5.000%	GE
*2, 3 GP : 0.7000	GP
*2, 3 GI : 4.000	GI
*2, 3 GD : 0.5000	GD
SHT LO : 0.5000 %IIN	Input valve for forced shut off valve
SHT HI : 109.00 %IIN	Input valve for forced full open valve
*6 SHUT : -7.314°	Shut position (Zero)
*6 OPEN : 7.318°	Open position (Span)
*4 INPUT : 12.00 mA	Input current value (mA)
*4 : 50.00 %IIN	Input current value (%)
*4 OUTPUT : 50.00 %STROKE	Valve position
*6 SPEED : 2.140 s	EPM (electropneumatic module) drive signal
*6 ERROR : 0.0960 %ERR	User-defined flow characteristics conversion data
*4 EPM : 58.20 %DUTY	
*5 UDC	
NO. IN % OUT %	
1 : -19999 , -19999	
2 : 0.000 , 0.000	
:	
:	
15 : 100.00 , 100.00	
16 : 19999 , 19999	
*4 STATUS CHECK = OK	Result of SVP self-diagnosis











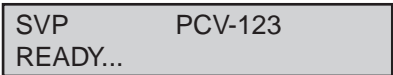

*1 Not printed when the actuator size is set at PARAM0.
 *2 Not printed when the actuator size is set at PARAM1 to 9.
 *3 Not printed when GE is set 0.
 *4 In case of minor trouble, # is printed at the right end.
 *5 Not printed when the output format is set at LINEAR, EQUAL %, or QUICK OPEN.
 *6 Printed when s/w version of SFC is 9.0 on late. These data are values in auto set-up.

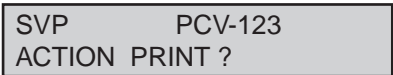
Continuous Response Printout (Action Print) [SVP/SVT]

This function continuously prints out the responses and results from the SVP in response to SFC key operations. This function is used when it is desirable to create a record of the operations performed.

Procedure

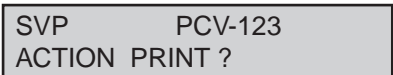
The procedure for continuous printing of SVP responses is shown below.

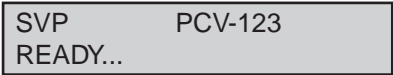
Step	Operation	SFC screen
1	Verify that the SFC is in the command wait state. <ul style="list-style-type: none"> If the screen at the right is not displayed, press . 	
2	Press  .	
3	Press  .	
4	Press  . <ul style="list-style-type: none"> The action print function starts by printing the following. * ACTION PRINT * START TAG No. PCV-123 '00-12-18 15:30 After that, it prints out the response to SFC key operations each time the SVP issues a response. 	
5	Press  to cancel the action print function.	
6	Press  .	
7	Press  . <ul style="list-style-type: none"> The action print function terminates by printing the following. * ACTION PRINT * END The SFC returns to the first screen (the command wait state). 	

4-13:Other functions

Current input correction (IIN CORRECT)











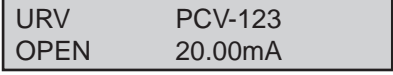

This function corrects for differences between the 4-20 mA current input from the controller and the 4-20 mA input signal certified by the SVP.

Procedure

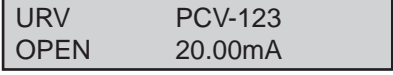
- 4 mA current input correction

Step	Operation	SFC screen
1	Verify that the SFC is in the SVP mode command wait state. <ul style="list-style-type: none"> • The mode is displayed at the upper left of the screen. 	
2	Press . <ul style="list-style-type: none"> • The current input mA value displayed at this point does not matter. 	
3	Press .	
4	Press . <ul style="list-style-type: none"> • The SFC will display only the current value. • The cursor will be displayed. 	
5	Press . <ul style="list-style-type: none"> • Set the input (controller output) to the SVP to 4 mA. 	
6	Press . <ul style="list-style-type: none"> • A correction performed. • After “4 mA IIN CORR?” is displayed, the display will switch to that shown at the right. 	
7	Press	

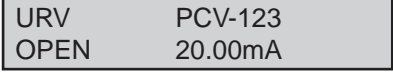
- 20 mA current input correction

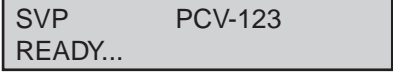







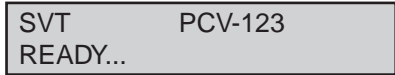

Step	Operation	SFC screen
1	Verify that the SFC is in the SVP mode command wait state. <ul style="list-style-type: none"> • The mode is displayed at the upper left of the screen. 	
2	Press  . <ul style="list-style-type: none"> • The current input mA value displayed at this point does not matter. 	
3	Press  .	
4	Press  . <ul style="list-style-type: none"> • The SFC will display only the current value. • The cursor will be displayed. 	
5	Press  . <ul style="list-style-type: none"> • Set the input (controller output) to the SVP to 20 mA. 	
6	Press  . <ul style="list-style-type: none"> • A correction performed. • After “20 mA IIN CORR?” is displayed, the display will switch to that shown at the right. 	
7	Press  .	



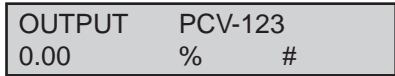

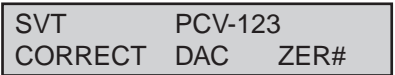



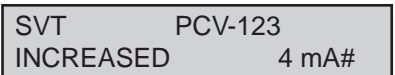

Current output correction (IOUT CORRECT)

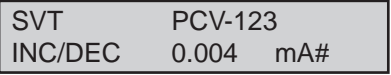
This function corrects the current values from the position transmission output.
Connect a current meter in the position transmission loop.





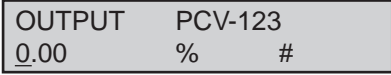









Procedure

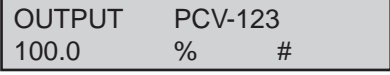

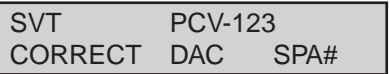

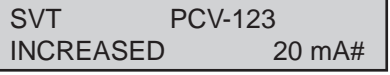

- Correction of the 4 mA (0%) output current value.

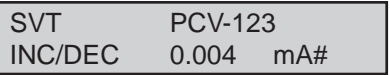
Step	Operation	SFC screen
1	Verify that the SFC is in the SVT mode command wait state. • The mode is displayed at the upper left of the screen.	 SVT PCV-123 READY...
2	Press  . After communication is established, press  and  in that order. • An output of 0% will be registered.	 OUTPUT PCV-123 0.00 % #
3	Press  . After communication is established, press  . • The correction operation will start.	 SVT PCV-123 CORRECT DAC ZER#
4	Use the  (increase) and  (decrease) keys to correct the current so that the current meter reads 4 mA. • The output will increase or decrease by 0.004 mA each time  or  is pressed.	 SVT PCV-123 INCREASED 4 mA#

Step	Operation	SFC screen
5	<p>Press  to select the amount of correction per step.</p> <ul style="list-style-type: none"> If an accurate correction was achieved at <step 4>, skip <steps 5> and <step 6>. Each time you press  the amount of correction (mA) changes as shown below. <p>→ 0.004 mA → 0.02 mA → 0.1 mA → 0.5 mA]</p>	
6	<p>Use the  (increase) and  (decrease) keys to correct the current so that the current meter reads 4 mA.</p> <ul style="list-style-type: none"> The output will increase or decrease each time a key is pressed by the amount selected in <step 5>. The amount of the correction can be changed by pressing . 	
7	<p>Press .</p>	
8	<p>Press .</p> <ul style="list-style-type: none"> The correction operation has completed when the screen no longer displays a sharp sign (#). 	

- Correction of the 20 mA (100%) output current value.

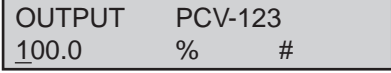
Step	Operation	SFC screen
1	Verify that the SFC is in the SVT mode command wait state. <ul style="list-style-type: none"> • The mode is displayed at the upper left of the screen. 	
2	Press  . After communication is established, press  ,  ,  ,  in that order. <ul style="list-style-type: none"> • An output of 100% will be registered. 	
3	Press  . After communication is established, press  . <ul style="list-style-type: none"> • The correction operation will start. 	
4	Use the  (increase) and  (decrease) keys to correct the current so that the current meter reads 20 mA. <ul style="list-style-type: none"> • The output will increase or decrease by 0.004 mA each time  or  is pressed. 	
5	Press  to select the amount of correction per step. <ul style="list-style-type: none"> • If an accurate correction was achieved at <step 4>, skip <step 5> and <step 6>. • Each time you press  the amount of correction (mA) changes as shown below. <div style="border: 1px solid black; padding: 2px; width: fit-content; margin: 5px auto;"> →0.004 mA →0.02 mA → 0.1 mA →0.5 mA] </div> 	

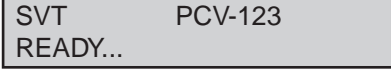
Step	Operation	SFC screen
6	Use the  (increase) and  (decrease) keys to correct the current so that the current meter reads 20 mA. <ul style="list-style-type: none"> • The output will increase or decrease each time a key is pressed by the amount selected in <step 5>. • The amount of the correction can be changed by pressing . 	
7	Press  .	
8	Press  . <ul style="list-style-type: none"> • The correction operation has completed when the screen no longer displays a sharp sign (#). 	









Simulated current input [SVP]

This function uses the SFC to set the input signal value regardless of the value of the input signal from the controller.

This function can be effective, for example, in isolating problems during troubleshooting. For example, if the control valve does not move in response to input signals from the controller, if the valve operates correctly in response to the simulated current input, then one can conclude that the problem is somewhere from the wiring to the host system.

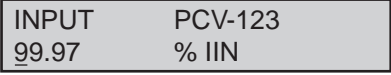
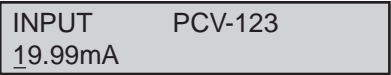
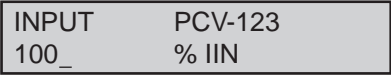

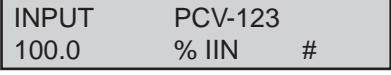



Setting the simulated current input value

The procedure for setting the simulated current input value is shown below.

Step	Operation	SFC screen
1	Verify that the SFC is in the SVP mode command wait state. <ul style="list-style-type: none"> The mode is displayed at the upper left of the screen. 	
2	Press  .	
3	Press  . <ul style="list-style-type: none"> The display will change every 6 seconds. 	 After 6 seconds: 
4	Use the SFC number keys to enter the simulated current input (%IIN) value. <ul style="list-style-type: none"> Enter numbers when the cursor is blinking. Any value may be entered. (The value 100 is used as an example here.) 	
5	Press  . <ul style="list-style-type: none"> The simulated input value is set in the SVP. 	
6	Press  . <ul style="list-style-type: none"> A sharp sign (#) will be displayed at the lower left of the screen. In this case, it means that the SFC is in the simulated input state. 	

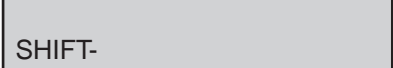
Releasing the stored current input value

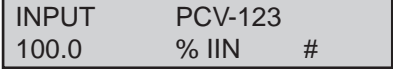
The procedure for releasing the stored current input value is shown below.

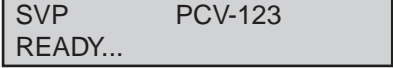
Step	Operation	SFC screen
1	Verify that the SFC is in the SVP mode command wait state. <ul style="list-style-type: none"> The mode is displayed at the upper left of the screen. 	
2	Press  .	
3	Press  .	
4	Press  . <ul style="list-style-type: none"> The simulated input is released. The sharp sign (#) is no longer displayed. 	

~Note *The simulated input will be automatically released after 10 minutes have passed.*

After turning off or cutting the current input signal to the SVP, the simulated input will be automatically released if the input signal is applied again.

EPM simulated drive signal setting [SVT]







- Normally, this function is not used.
- This function cuts the drive signal from the PID control unit block, and sets the simulated drive signal to the EPM (electro-pneumatic converter module).

Setting the EPM simulated drive signal

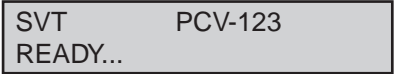
The procedure for setting the EPM simulated drive signal is shown below.

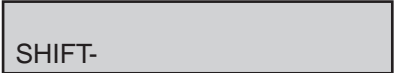
Step	Operation	SFC screen
1	Verify that the SFC is in the SVT mode command wait state. <ul style="list-style-type: none"> • The mode is displayed at the upper left of the screen. 	
2	Press .	
3	Press . <ul style="list-style-type: none"> • Data is read in once every 6 seconds. • The value of the duty percentage displayed may differ. (The value shown, a 52.40% duty, is one example.) 	
4	Use the SFC number keys to enter the value for the simulated drive signal (%DUTY). <ul style="list-style-type: none"> • Enter numbers when the cursor is blinking. • Any value may be entered. (The value 100 is used as an example here.) 	
5	Press . The simulated drive signal will be input to the EPM (Electro-Pneumatic converter Module).	
6	Press . <ul style="list-style-type: none"> • A sharp sign (#) will be displayed at the lower right of the screen. In this case, it means that the SFC is in the simulated input state. 	

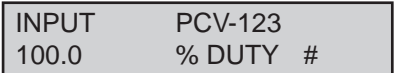
Canceling the registered simulated signal

Step	Operation	SFC screen
1	Verify that the SFC is in the SVT mode command wait state. <ul style="list-style-type: none"> The mode is displayed at the upper left of the screen. 	
2	Press  .	
3	Press  .	
4	Press  . <ul style="list-style-type: none"> The simulated input is released. The sharp sign (#) is no longer displayed. 	

~Note *The simulated input will be automatically released after 10 minutes have passed.*

After turning off or cutting the current input signal to the SVP, the simulated input will be automatically released if the input signal is applied again.

Simulated position transmission output [SVT]

This function outputs a simulated current signal set with the SFC regardless of the actual position. An arbitrary constant-current value can be output to the position transmission output loop without changing the position.





This function is useful for performing a loop check of the position transmission output loop and for other tests.

Setting the simulated position transmission output value

The procedure for setting the simulated position transmission output value is shown below.

Step	Operation	SFC screen
1	Verify that the SFC is in the SVT mode command wait state. <ul style="list-style-type: none"> The mode is displayed at the upper left of the screen. 	
2	Press . <ul style="list-style-type: none"> The display will change every 6 seconds. 	
3	Use the SFC number keys to enter the simulated position transmission output (%) value. <ul style="list-style-type: none"> Enter numbers when the cursor is blinking. 	
4	Press . <ul style="list-style-type: none"> The simulated current is output from the SVP. 	
5	Press . <ul style="list-style-type: none"> A sharp sign (#) will be displayed at the lower right of the screen. In this case, it means that the SFC is in the simulated output state. 	

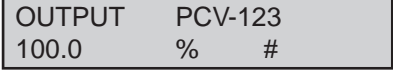
Canceling the registered output value

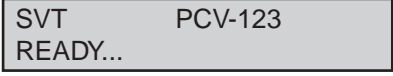
Step	Operation	SFC screen
1	Verify that the SFC is in the SVT mode command wait state. <ul style="list-style-type: none"> The mode is displayed at the upper left of the screen. 	
2	Press  . <ul style="list-style-type: none"> The display will change every 6 seconds. 	
5	Press  . <ul style="list-style-type: none"> This cancels the constant-current output (output mode). The sharp sign (#) is no longer displayed. 	

~Note *The constant-current output will be automatically released after 10 minutes have passed.*

After turning off or cutting the current input signal to the SVP, the constant-current output will be automatically released if the input signal is applied again.

Restoring factory data [SVP/SVT]







It is possible to restore all the SVP internal data settings to settings state at the point the product was shipped from the factory. This function can be useful if the data has been modified to the point that it is not clear what settings are the problem.

~Note *When this function is executed, the valve fully open and fully closed positions (zero and span adjustments) are also returned to the factory state. When the SVP is operated again, write the settings once more.*

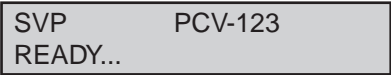
If the save settings data (USER DATA SAVE) function in the configuration settings is executed before this function is executed, this function will restore the internal data saved at that time.

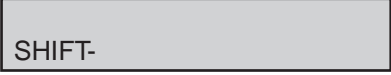
Procedure

The procedure for recalling the factory data is given below.

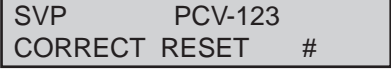
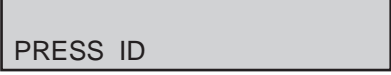
Step	Operation	SFC screen
1	Verify that the SFC is in the command wait state. <ul style="list-style-type: none"> The mode is displayed at the upper left of the screen. 	
2	Press  .	
3	Press  .	
4	Press  . <ul style="list-style-type: none"> The saved settings data will be recalled. Press  if you do not want to restore these settings. 	
5	Press any key. <ul style="list-style-type: none"> Next, start operating the positioner from the start of communication step. 	

Switching between analog and digital output [SVP/SVT]









The format of the SVP position transmission output can be switched from analog to digital or from digital to analog. (Model AVP301 and 201)

WARNING

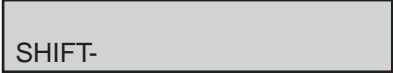
The valve may move when the position transmission output format is switched. Prepare yourself and the process in advance so that no one is injured and the process is not adversely affected when the valve operates. Also take appropriate actions, such as switching to manual mode, so that host control equipment is not adversely affected.

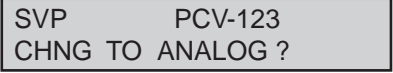
Procedure

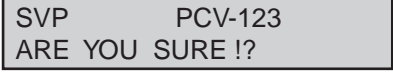
The procedure for switching the SVP output format is given below.

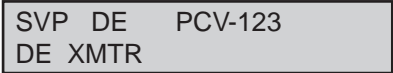
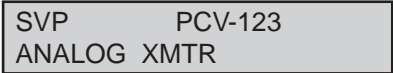
Step	Operation	SFC screen
1	Verify that the SFC display screen indicates that the SFC is in the command wait state. <ul style="list-style-type: none"> Press  if the SFC displays any screen other than that shown at the right. 	
2	Press  .	
3	Press  . <ul style="list-style-type: none"> The screen at the right will be displayed if the current output is set to analog. The screen at the right will be displayed if the current output is set to digital. 	 
4	Press  . <ul style="list-style-type: none"> Press  to cancel the output switching operation. The SFC will return to the screen shown at <step 1>. 	
5	Press  . <ul style="list-style-type: none"> The switching operation is performed. After displaying the screen shown at the right, the SFC will switch to the command wait state. 	 (For digital output)  (For analog output)

Setting the digital output format [SVP/SVT]

This operation sets up the output signal mode, the amount of information mode, and other aspects when the position transmission output function is used in digital (DE) output mode. This section describes this operation focusing on the manipulations performed.

Digital (DE) output format

Bidirectional communication with the host system is possible when the SVP position transmission output function is set to digital (DE) output mode. There are three setting values here that correspond to the different operations performed using this communication.

Output signal mode setting

The output data type is selected from the following three options.

- Single range (Single Range)
- Single range with sampled variable (Single Range W/SV)
- Dual range (Dual Range)

~Note *The SVP PV value is the position, and the sampled variable is the SVP internal temperature.*

Amount of information mode setting

The number of bytes in the output data can be selected to be one of the following two options.

- DE - 4 bytes (DE-4 BYTE)
- DE - 6 bytes (DE-6 BYTE)

~Note *If the STIM II interface is used, select 6-byte mode to take the maximum advantage of the merits of bidirectional integration.*













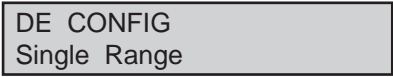

Failsafe mode setting

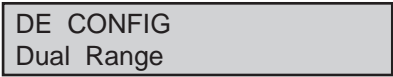

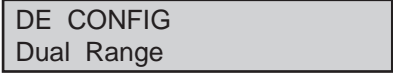

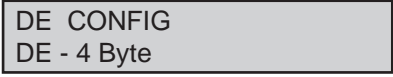

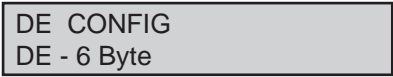
This setting selected the type of failsafe mode used.

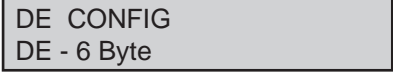
~Note *Since the failsafe mode is set by the STIM II (the host system), this setting is invalid.*

Procedure

The procedure for setting the digital (DE) output format is given below.

Step	Operation	SFC screen
1	Verify that the SFC display screen indicates that the SFC is in the command wait state.	
2	Press  .	
3	Press  . <ul style="list-style-type: none"> The SFC switches to DE configuration mode. The screen for setting the output signal mode is displayed. 	
4	Press  until the mode to be selected is displayed. <ul style="list-style-type: none"> Proceed to step 6 if you do not need to change the mode. 	
5	Press  . <ul style="list-style-type: none"> This confirms the mode. 	
6	Press  . <ul style="list-style-type: none"> The amount of information mode setup screen is displayed. 	
7	Press  until the mode to be selected is displayed. <ul style="list-style-type: none"> Proceed to step 9 if you do not need to change the mode. 	
8	Press  . <ul style="list-style-type: none"> This confirms the mode. 	

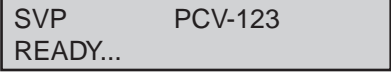
Step	Operation	SFC screen
9	Press  . <ul style="list-style-type: none"> The failsafe mode setup screen is displayed. Normally, this mode is not changed here. (This setting is invalid.) 	
10	Press  . <ul style="list-style-type: none"> The SFC asks if you want to register (transfer) the settings. 	
11	Press  . <ul style="list-style-type: none"> The settings are registered (transferred). After registration (transfer), the SFC exits DE configuration mode. • Press  to not register (transfer) the settings.	

~Note *The basic operations here are the same as those for configuration setup (SVP/CONFIG).*

Chapter 5: Configuration using a HART Communicator

This chapter describes operating the Yamatake model AVP302 and AVP202 valve positioner using HART protocol communication. A HART Communicator is used for adjustment, setup, data readout from, and other operations on the model AVP302 and AVP202 product. Refer to the user's manual for the HART Communicator from Emerson Electric Co. for information on the use of the HART Communicator itself.

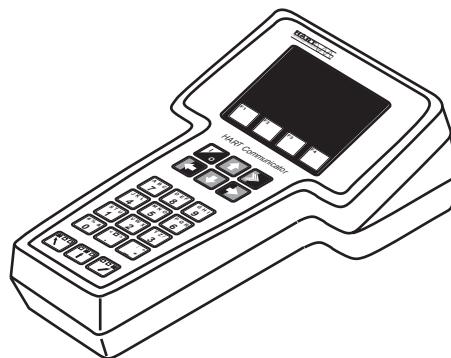

Figure 5-1 HART Communicator

5-1: HART communicator functions

The following operations can be performed using the HART Communicator.

Operations	Page
Starting communication	5-4
Verifying and modifying the general information	
• Device information	5-6
• Manufacturer	5-7
Device condition	
• Current input value (units: mA)	5-8
• Input signal% (percentage) value (units:%)	5-8
• Valve travel (units:%)	5-8
• Drive sig (EPM (Electro Pneumatic converter Module) drive signal) (units:%)	5-8
• Temperature (Equipment internal temperature) (units: °C)	5-9
• Last config data	
Config & Calib (Equipment setup and calibration)	
• Mode (Switching the SVP mode)	5-10
• Input signal range (Setting the current input values)	5-10
• Valve sys config (Valve system configuration)	5-11
• Dynamic chara (Dynamic characteristics)	5-12
• Valve chara (Valve characteristics)	5-14
• Tvl cut off (Travel cut off)	5-15
• Calibrate	5-16
• Diag parameters (Diagnostic parameters)	5-17
• Burst mode	5-24
Initial setup	5-25
Maintenance	
• Dummy input sig (Dummy input signal)	5-26
• Dummy drive sig (Dummy drive signal)	5-26
• User data save	5-27
• Correct reset	5-27
Device status	
• Failures	5-28
• Notices	5-28
• Valve diagnostics	5-29

HART Communicator menu tree

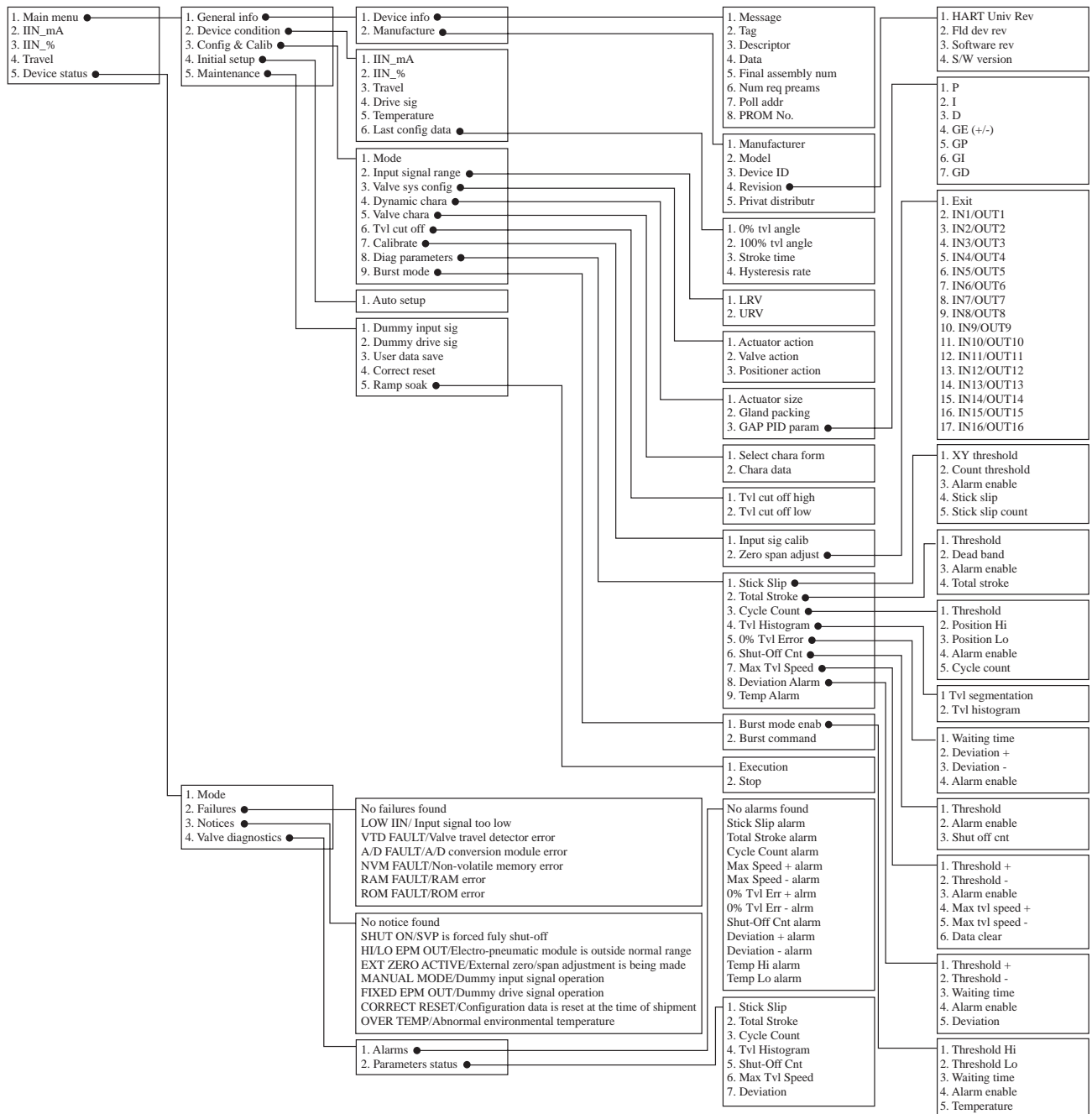

- ~Notes**
- Refer to the HART Communicator user's manual provided by Emerson Process Management when using the HART Communicator.
 - This manual describes the functions of the model AVP302/202 version listed below.
 Field device revision: 2
 Software revision:1 (Yamatake Software ver. 3.A)
 HART Universal command revision: 5
 - When operating the model AVP302/202 with a HART Communicator, update the HART Communicator firmware and modules as required.
 - Also note that the SVP device descriptions are registered at the local programming site in each country.

5-2: Starting communication

This section describes the wiring used for communication between the HART Communicator and the model AVP302/202. The input signal line from the controller is used for the communication line between the HART Communicator and the model AVP302.

Before starting communication

Verify the following points before starting communication.

- Verify that the cable connection between the SVP and the HART Communicator is correct and complete. (See “Chapter 2: Installation”.)
- Verify that an input signal (power supply) from the controller (constant current power supply) is provided.

~Note *If it is not possible to provide a 4-20 mA DC signal from the controller, connect a constant current power supply (3.85 to 21.5 mA DC) to the input signal terminals. The lines from the controller must be removed from the terminals before connecting the constant current power supply.*

Procedure

- (1) Connect an input signal line to the HART Communicator.

WARNING

If the HART Communicator is to be used in an environment with an explosive atmosphere, the communicator itself must have explosionproof specifications and non-incendiary wiring must be used. If the HART Communicator used does not meet these conditions, it must not be in an explosive atmosphere.

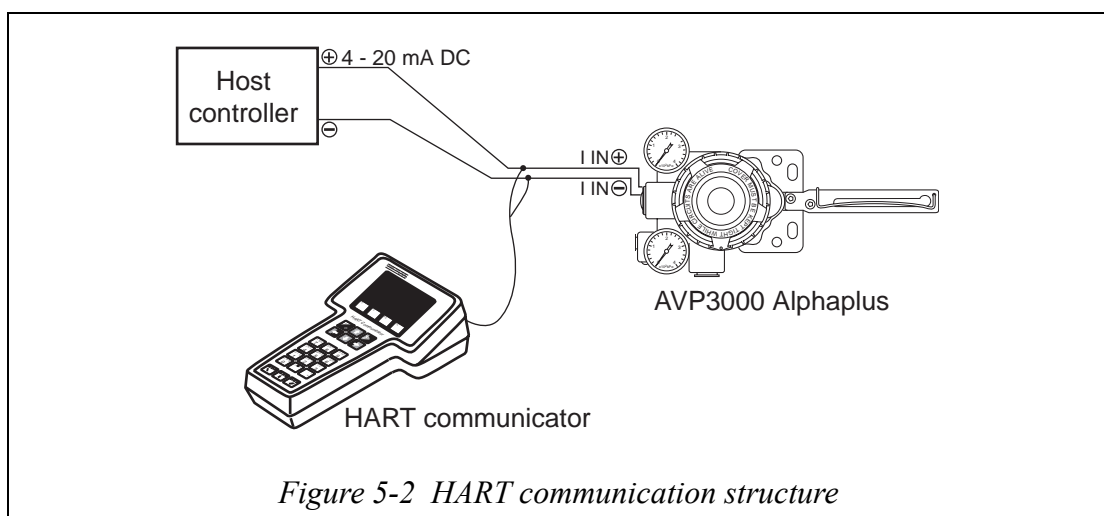

(2) Press the [I/O] button to turn on the HART communicator power.

The initial screen shown below will be displayed and communication will start.

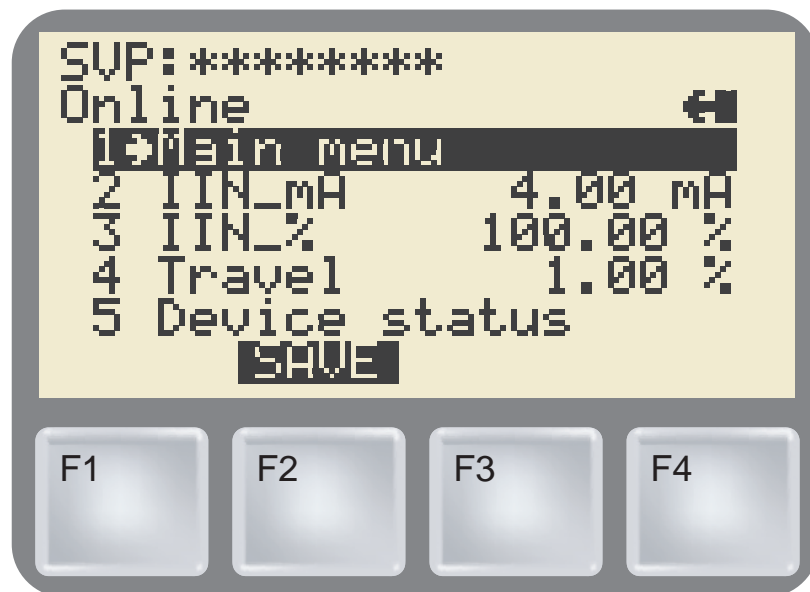

5-3: Verifying and modifying the general information

This section describes verifying and modifying the equipment information for the model AVP302/202 connected to the HART Communicator.

Device information

Procedure

Select [Main menu] >> [General info] >> [Device info], and verify and modify the following items as required.

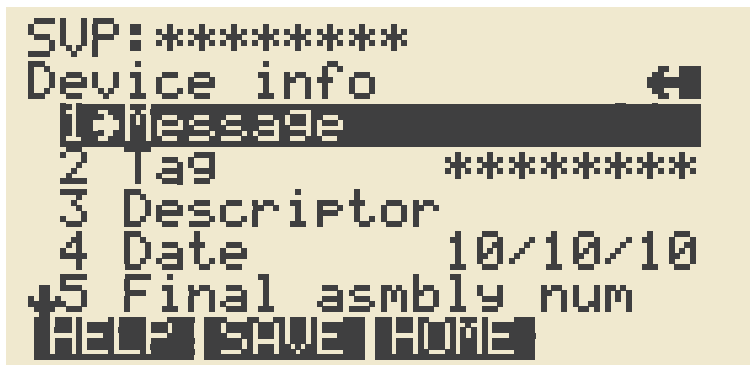

Menu	Function
1 Message	Verifies and/or modifies the messages registered in the SVP.
2 Tag	Verifies and/or modifies the tag number allocated to the equipment.
3 Descriptor	Verifies and/or modifies the equipment type information required for equipment management.
4 Date	Verifies and/or modifies the date of the last setup operation and other special dates in the equipment.
5 Final assembly num (Final assembly number)	Verifies and/or modifies the date of the last setup operation and the special management numbers in the equipment and system.
6 Num req params (Number of requested preambles)	Verifies the number of preambles characteristic to the equipment.
7 Poll addr (Polling address)	Specifies the equipment address when multiple units are connected in the same loop, for example when split range operation is used.
8 PROM No.	Verifies the model AVP302/202 ID information.

Manufacturer

Procedure

Select [Main menu] >> [General info], and verify and modify the following items as necessary.

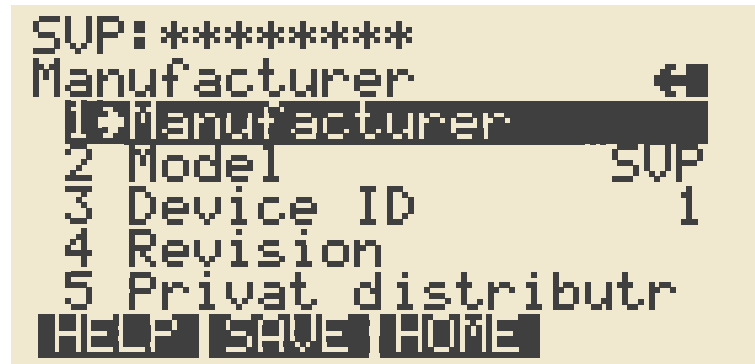

Menu	Function
1 Manufacturer	Verifies the manufacturer of the equipment. “Yamatake Corporation” will be displayed.
2 Model	Verifies the name and model number of the equipment. “SVP” will be displayed.
3 Device ID	Verifies the unique ID information for the equipment.
4 Revision	Verifies the version information for the equipment software. The following items can be verified. HART Universal command revision Displays the revision number of the HART universal commands supported by the model AVP302/202. Fld dev rev (Field device revision) Displays the version number for the device description. Software rev (Software revision) Displays the version number for the software within the same field device revision. S/W ver. Displays the version number of the software. This is a Yamatake corporate internal management number, and is in a one-to-one correspondence with the Software revision item described above.
5 Privat distributr (Private label distributor)	Verifies the private label distributor of the equipment

5-4: Device condition

This mode allows the display of measured values during equipment operation and the verification of adjustment data. Use the following procedure to verify and set this data.

Current input value (units: mA)

Select [Main menu]
 >> [Device condition]
 >> [IIN_mA].

```
SUP:***** 0
IIN_mA
4.00 mA
EXIT
```

Input signal% (percentage) value (units:%)

Select [Main menu]
 >> [Device condition]
 >> [IIN_%].

```
SUP:***** 0
IIN_%
100.00 %
EXIT
```

Valve travel (units:%)

Select [Main menu]
 >> [Device condition]
 >> [Travel].

```
SUP:***** 0
Travel
1.00 %
EXIT
```

Drive sig (EPM (Electro Pneumatic converter Module) drive signal) (units:%)

Select [Main menu]
 >> [Device condition]
 >> [Drive sig].

Temperature (Equipment internal temperature) (units: °C)

Select [Main menu]
 >> [Device condition]
 >> [Temperature].

```
SUP:*****
Temperature
1.00 degC
( 33.80 degF)
HEART OK
```

Last config data

0% tvl angle (VTD sensor angle when fully closed) (units: degrees)

Displays the angle set as the point where the valve is fully closed.

Procedure

- Select [Main menu]
 - >> [Device condition]
 - >> [Last config data]
 - >> [0% tvl angle].

```
SUP:*****  
0% tvl angle  
0.96 deg  
  
ABORT | OK
```

100% tvl angle (VTD sensor angle when fully open) (units: degrees)

Displays the angle set as the point where the valve is fully open.

Procedure

- Select [Main menu]
 - >> [Device condition]
 - >> [Last config data]
 - >> [100% tvl angle].

```
SUP:*****  
100% tvl angle  
1.00 deg  
  
ABORT | OK
```

Stroke time (units: seconds)

Displays the valve full stroke time measured when auto setup was run.

Procedure

- Select [Main menu]
 - >> [Device condition]
 - >> [Last config data]
 - >> [Stroke time]

```
SUP:*****  
Stroke time  
100.00 s  
  
ABORT | OK
```

Hysteresis rate (units:%)

Displays the friction level of the gland pack measured when auto setup was run.

Procedure

- Select [Main menu]
 - >> [Device condition]
 - >> [Last config data]
 - >> [Hysteresis rate].

```
SUP:*****  
Hysteresis rate  
100.00 %  
  
ABORT | OK
```

5-5: Config & Calib (Equipment setup and calibration)

The setup and calibration procedure sets up and calibrates the required basic functions for the equipment to operation correctly.

Before setting up the equipment, set the SVP mode to Out of service.

CAUTION

After completing calibration or adjustment, or after changing settings, return the mode to In service.

Mode (Switching the SVP mode)

The SVP has two modes: In service and Out of service.

When performing calibration or adjustment, or when changing settings, first verify that these operations will not result in problems that could adversely influence plant operation. Then set the mode to Out of service.

After completing calibration or adjustment, or after changing settings, return the mode to In service. These operations cannot be performed when the SVP mode is In service.

Procedure

- Select [Main menu] >> [Config & Calib] >> [Mode].
- Select the SVP mode (Out of service or In service) from the Mode menu.

Input signal range (Setting the current input values)

This procedure sets the current input value when the valve is fully closed (LRV) and the current input value when the valve is fully open (URV).

An input in the range 4-20 mA can be used.

A split range can also be set up easily.

CAUTION

- Set these values so that the current input span ($|LRV - URV|$) is in the range 4 to 16 mA.
- If the span is under 8 mA, the precision will be 1.5% of full scale.

Procedure

- Select [Main menu] >> [Config & Calib] >> [Input signal range] >> [LRV].
- Apply the current input value for the valve fully closed position and press F4.
- Select [Main menu] >> [Config & Calib] >> [Input signal range] >> [URV].
- Apply the current input value for the valve fully open position and press F4.

Valve sys config (Valve system configuration)

This procedure set the control valve control system.

Actuator action

- Selects the operating direction of the actuator.
- Selects direct or reverse action (DIRECT/REVERSE). Specify direct operation (DIRECT) if the feedback lever is to move from higher to lower positions as the air pressure increases, or specify reverse operation (REVERSE) if the feedback lever is to move from lower to higher positions.

Procedure

- Select [Main menu] >> [Config & Calib] >> [Valve sys config] >> [Actuator action].
- Select the actuator operating direction (Direct or Reverse) and press F4.

Valve action

- Selects the direction of the valve plug.
- Selects direct or reverse plug action (DIRECT/REVERSE). Specify direct operation (DIRECT) if the feedback lever is to move from higher to lower positions when the control valve moves in the open to closed direction, or specify reverse operation (REVERSE) if the feedback lever is to move from lower to higher positions. See “3-2: Zero-Span adjustment” on page 3-6., in this section for the method for making this selection.

Procedure

- Select [Main menu] >> [Config & Calib] >> [Valve sys config] >> [Valve action].
- Select the valve operating direction (Direct or Reverse) and press F4.

Positioner action

- Selects the operating direction of the positioner.
- Selects direct or reverse action (DIRECT/REVERSE). Specify direct operation (DIRECT) if the SVP output air pressure should go to zero if the power supply is disconnected, or specify reverse operation (REVERSE) if the SVP output air pressure should go to its maximum pressure.

The operating direction of the positioner is determined by the main unit hardware. The operating direction cannot be switched with this function. This item must be set to match the direction of the main unit specifications. Contact your Yamatake service representative to change the operating direction.

Procedure

- Select [Main menu] >> [Config & Calib] >> [Valve sys config] >> [Positioner action].
- Select the positioner operating direction (Direct or Reverse) and press F4.

Dynamic chara (Dynamic characteristics)

Actuator size

- Selects the size of the actuator.
 - Select one of parameter 0 to parameter 9 (PARAM0 to PARAM9).
- ~Note** *The parameter set here determines PID calculation parameters used to control the control valve (That is, the dynamic characteristics are determined by this setting.)*
If parameter 0 (PARAM0) is selected, it will be possible (and necessary) to perform the settings described in (B) Dynamic characteristics data settings (CTL CONFIG), this setting is not used.

Procedure

- Select [Main menu] >> [Config & Calib] >> [Dynamic chara] >> [Actuator size].
- Select the parameter (Param 0 to 9) for the actuator size and press F4.
- If parameter 0 is selected, set the gap PID parameters.

Gland packing

- Selects the magnitude of the hysteresis difference due to friction in the control valve gland packing.
 - Select one of heavy, medium, or light (HEAVY, MEDIUM, or LIGHT).
 - Refer to “Table 5-2: Hysteresis Parameter table” and select a parallel appropriate for the gland packing material.
- ~Note** *The parameter set here determines PID calculation parameters used to control the control valve*
This setting is not required if parameter 0 (PARAM0) in item (4) Actuator Size Selection is selected.

Table 5-1: PID parameter table

Actuator diaphragm capacity (cm ³)	Actuator model ^{*i}	Parameter (PARAM)
1000	HA1, VA1, PSA1	1
3500	HA2, VA2, PSA2	2
7600	HA3, VA3, PSA3	3
14000	HA4, VA4, PSA4	4
25300	VA5	5
8400	VA6, PSA6	6
760	VR1	7
2200	VR2	8
5800	VR3	9
Values other than the above ^{*ii}	—	0 ^{*ii}

Note) ^{*i}. This is set according to the specifications and model number when shipped from the factory.

Note) ^{*ii}. Consult with your Yamatake service representative.

Table 5-2: Hysteresis Parameter table

Gland packing material example	Hysteresis (HYSTERESIS)
Graphite packing	Heavy (HEAVY)
Yarn packing	Medium (MEDIUM)
Type V PTFE packing	Light (LIGHT)

Procedure

- Select [Main menu] >> [Config & Calib] >> [Dynamic chara] >> [Gland packing].
- Select the gland packing parameter (Light, Medium, or Heavy) and press F4.

Gap PID param (Gap PID parameters)

This item allows you to set the dynamic characteristics data freely.

~Note *It will be possible (and necessary) to perform these settings only if parameter 0 (PARAM0) is selected in the actuator size selection (ACTUATOR SIZE) item in the basic data settings.*

The gap-action type PID method is adopted in the SVP to determine the dynamic characteristics.

In the gap-action type PID method, deviation values (the gap) above and below the target value are set up, and the PID parameters are changed depending on whether the process value is inside or outside the gap.

This method has the advantages that both rapid response characteristics and stability can be achieved with relatively simple tuning.

Procedure

- Select [Main menu] >> [Config & Calib] >> [Dynamic chara] >> [Gap PID parameters].
- Enter the numeric values for the 7 PID parameters (P, I, D, GE, GP, GI, and GD) and press F4.

Valve chara (Valve characteristics)

Select chara form

This item allows you to select flow characteristics.

The user can also set arbitrary characteristics.

- One of linear, equal percent, quick open, and user (LINEAR, EQUAL%, QUICK OPEN, and USER) can be selected as the flow characteristics.

Procedure

- Select [Main menu] >> [Config & Calib] >> [Valve chara] >> [Select chara form].
- Select the positioner flow characteristics (Linear, Quick opening, EQ%, or User defined).
- If the user defined characteristics option was selected, set up the flow characteristics conversion data.

Chara data

This item, (D) Setting the Flow Characteristics Conversion Data (CNV CONFIG), allows you to set up converted data for arbitrary user flow characteristics.

~Note *It will be possible (and necessary) to perform these settings only if user (USER) is selected in **setting the flow characteristics**.*

- There are 16 data points, corresponding to P = 1 to P = 16.
- For each point, both the input signal (IN%) and position (OUT%) are specified.
- The characteristics will consist of the line formed by linearly interpolating between adjacent points.

~Note *All 16 points (input value and valve position) must be set.*

The values P = 1 to P = 16 must be set in order of increasing input values, starting with the smallest value.

The values used must have the property that no inflection points exist, that is, they must be monotonic increasing.

Values in the range -19999 to +19999 can be entered.

Procedure

- Select [Main menu] >> [Config & Calib] >> [Valve chara] >> [Chara data].
- Select IN1/OUT1 from the Chara data menu, and set the input signal (IN1%) and the position (OUT1%).
- Set the values for IN2/OUT2 through IN16/OUT16 in the same manner.

Printing the characteristics curve

The following presents an example of printing the characteristics curve and the input data used.

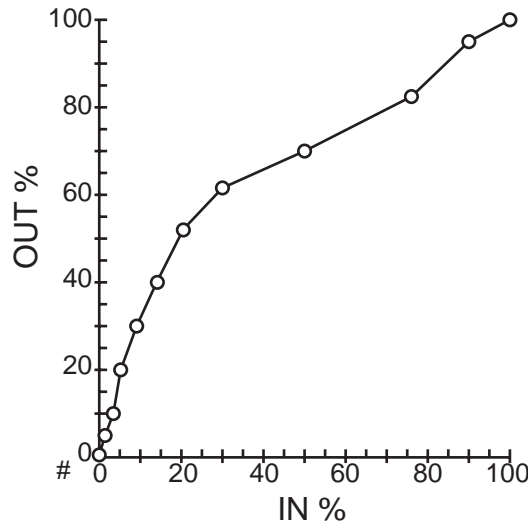

Point	SFC IN % ENTRY (Control signal input %)	SFC OUT % ENTRY (Valve travel %)
1	-19999	-19999
2	0.000	0.000
3	2.0	5.0
4	2.9	10.0
5	4.7	20.0
6	7.6	30.0
7	12.4	40.0
8	20.2	50.0
9	32.7	60.0
10	53.1	70.0
11	76.5	80.0
12	90.7	90.0
13	100.0	100.0
14	200.0	200.0
15	400.0	400.0
16	19999	19999

Figure 5-3

Tvl cut off (Travel cut off)

This item allows you to set the current input values (%) that forcibly full open and full closed the valve.

Forced fully open/fully closed settings

- The valve will be fully closed at input values less than the forced fully closed value, and it will be fully open at input values greater than the forced fully open value.
- The forced fully closed and forced fully open values can be set independently as percentages, IIN, of the current input value.
- The figure below presents an overview of the I/O characteristics when the forced fully closed and forced fully open values have been set.

~Note These parameters must be set to values such that the forced fully open value (SHUT OFF VALUE) is strictly less than the forced fully open value (FULL OPEN VALUE).

Values in the range -19999 to +19999 can be entered.

If the span setting is adjusted after an auto-setup operation, change the forced fully open value (FULL OPEN VALUE) to be 1% less than the overstroke percentage.

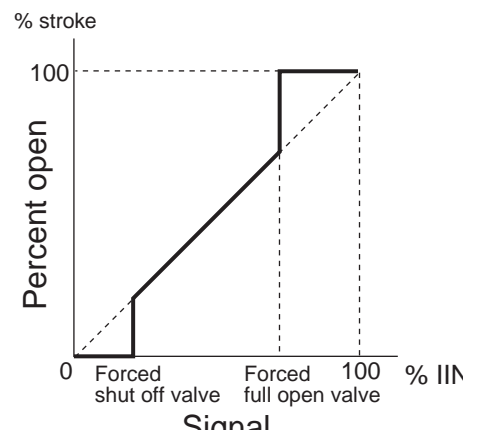

Figure 5-4 Forced fully open and forced fully closed values

Procedure

Tvl cut off high

- Select [Main menu] >> [Config & Calib] >> [Tvl cut off] >> [Tvl cut off high].
- Enter the forced fully open value as a percent of current input value and press F4.

Tvl cut off low

- Select [Main menu] >> [Config & Calib] >> [Tvl cut off] >> [Tvl cut off low].
- Enter the forced fully closed value as a percent of current input value and press F4.

Calibrate

Input sig Calib (Input signal calibration)

This function corrects for differences between the 4-20 mA current input from the controller and the 4-20 mA input signal certified by the SVP.

Current input 4 mA calibration procedure

- Select [Main menu] >> [Config & Calib] >> [Calib] >> [Input sig calib] >> [4 mA calib].
- Set the current input (controller output) to 4 mA and press F4.
- When the confirm update message is displayed, press F4.
- When the update completed message is displayed, press F4.

Current input 20 mA calibration procedure

- Select [Main menu] >> [Config&Calib] >> [Calib] >> [Input sig calib] >> [20 mA calib].
- Set the current input (controller output) to 20 mA and press F4.
- When the confirm update message is displayed, press F4.
- When the update completed message is displayed, press F4.

Zero span adjust

This section describes the procedures for adjusting zero and span using HART Communicator. See “3-2: Zero-Span adjustment” on page 3-6. for an overview of the zero and span adjustments.

Zero and span adjustment using the HART Communicator procedure

<Setting the valve fully closed position>

- Select [Main menu] >> [Config & Calib] >> [Calib] >> [Zero span adjust]>> [Angle adjust]>> [Zero].
- Set up a current input value such that the valve closes fully and press F4.
- Select the combination of the amount of angle by which to adjust the setting from the Zero adjust menu (for example, to increase by 0.006°, select increment/0.006) and press F4.
- Repeat the above operation several times. When the zero point has been adjusted, select [Exit] and press F4.

<Setting the valve fully open position>

- Select [Main menu] >> [Config & Calib] >> [Calib] >> [Zero span adjust] >> [Angle adjust] >> [Span].
- Set up a current input value such that the valve opens fully and press F4.
- Select the combination of the amount of angle by which to adjust the setting from the Zero adjust menu (for example, to increase by 0.006°, select increment/0.006) and press F4.
- Repeat the above operation several times. When the zero point has been adjusted, select [Exit] and press F4.

Changing the air supply pressure while adjusting the position procedure

<Setting the valve fully closed position>

- Apply a current value (any value) in the range 4-20 mA from the controller.
- Use the A/M switch to switch to manual operating mode. (See “6-1: Auto/Manual selection switch” on page 6-1.)
- Select [Main menu] >> [Config & Calib] >> [Calib] >> [Zero span adjust] >> [Manual adjust] >> [Zero].
- Adjust the supplied air pressure using a regulator so that the valve closes fully and press F4.
- When the confirm update message is displayed, press F4.
- When the update completed message is displayed, press F4.

<Setting the valve fully open position>

- Apply a current value (any value) in the range 4-20 mA from the controller.
- Use the A/M switch to switch to manual operating mode. (See “6-1: Auto/Manual selection switch” on page 6-1.)
- Select [Main menu] >> [Config & Calib] >> [Calib] >> [Zero span adjust] >> [Manual adjust] >> [Span].
- Adjust the supplied air pressure using a regulator so that the valve opens fully and press F4.
- When the confirm update message is displayed, press F4.
- When the update completed message is displayed, press F4.

Diag parameters (Diagnostic parameters)

1. Stick Slip

Stick Slip is the value that substitute sticky movement of the valve which is broken out by bites or fixation.

XY threshold

When Stick Slip becomes bigger than this value, it is a value to count it.

Procedure: Select [Main menu] >> [Config & Calib] >> [Diag parameters] >> [Stick Slip] >> [XY Threshold].

Enter the XY threshold and press F4.

Count threshold

When the number that the Stick Slip value became bigger than XY value becomes bigger than this value, alarm is sent.

Procedure: Select [Main menu] >> [Config & Calib] >> [Diag parameters] >> [Stick Slip] >> [Count threshold].

Enter the Count threshold and press F4.

Alarm enable

Select the enable/Disable of alarm.

Procedure: Select [Main menu] >> [Config & Calib] >> [Diag parameters] >> [Stick Slip] >> [Alarm enable].

Select the Enable/Disable of alarm and press F4.

Stick Slip

Procedure: Select [Main menu] >> [Config & Calib] >> [Diag parameters] >> [Stick Slip] >> [Stick Slip].

2. Total Stroke

Total stroke is the totalized distance that the stem has moved.

Threshold

When Total Stroke becomes bigger than this value, alarm is sent.

Procedure: Select [Main menu] >> [Config & Calib] >> [Diag parameters] >> [Total Stroke] >> [Threshold].

Enter the threshold and press F4.

Dead band

Dead band is the smallest value to count Total Stroke.

Procedure Select [Main menu] >> [Config & Calib] >> [Diag parameters] >> [Total Stroke] >> [Dead band].

Enter the Dead band and press F4

Alarm enable

Select the Enable/Disable of alarm.

Procedure: Select [Main menu] >> [Config & Calib] >> [Diag parameters] >> [Total Stroke] >> [Alarm enable].

Select the Enable/Disable of alarm and press F4.

Total Stroke

Procedure: Select [Main menu] >> [Config & Calib] >> [Diag parameters] >> [Total Stroke] >> [Total Stroke].

3. Cycle Count

Cycle count is the number that how many times the valve travel is over the Position Hi or Position Lo.

Threshold

When Cycle Count becomes bigger than this value, alarm is sent.

Procedure: Select [Main menu] >> [Config & Calib] >> [Diag parameters] >> [Cycle Count] >> [Threshold].

Enter the threshold and press F4.

Position Hi, Position Lo

Procedure:

Position Hi

Select [Main menu] >> [Config & Calib] >> [Diag parameters] >> [Cycle Count] >> [Position Hi].

Enter the [Position Hi] and press F4.

Position Lo

Select [Main menu] >> [Config & Calib] >> [Diag parameters] >> [Cycle Count] >> [Position Lo].

Enter the [Position Lo] and press F4.

Alarm enable

Select the Enable/Disable of alarm.

Procedure: Select [Main menu] >> [Config & Calib] >> [Diag parameters] >> [Cycle Count] >> [Alarm enable].

Select the Enable/Disable of alarm and press F4.

Cycle count

Procedure: Select [Main menu] >> [Config & Calib] >> [Diag parameters] >> [Cycle Count] >> [Cycle count].

4. Tvl Histogram (Travel Histogram)

Tvl Histogram shows the frequency of the valve travel position in each band width of max. 16.

Tvl segmentation (Travel segmentation)

Tvl segmentation is the valve travel position in each band width of max. 16.

Procedure: Select [Main menu] >> [Config & Calib] >> [Diag parameters] >> [Tvl Histogram] >> [Tvl segmentation].

Set the Tvl segmentation and press F4.

Tvl histogram (Travel Histogram)

Procedure: Select [Main menu] >> [Config & Calib] >> [Diag parameters] >> [Tvl Histogram] >> [Tvl histogram].

5. 0% Tvl Error (0% Travel Error)

0% Tvl Error is alarm of the deviation with the current zero position and setting zero position.

Waiting time

When the zero position error continues for a longer time than this waiting time, alarm is sent.

Procedure: Select [Main menu] >> [Config & Calib] >> [Diag parameters] >> [0% Tvl Error] >> [Waiting time].

Enter the Waiting time and press F4.

Deviation

When the error becomes bigger than this value and the deviation error continues for a longer time than waiting time, alarm is sent.

Procedure:

Deviation +

Select [Main menu] >> [Config & Calib] >> [Diag parameters] >> [0% Tvl Error] >> [Deviation +].

Enter the Deviation + and press F4.

Deviation -

Select [Main menu] >> [Config & Calib] >> [Diag parameters] >> [0% Tvl Error] >> [Deviation -].

Enter the Deviation - and press F4.

Alarm enable

Select the enable/Disable of alarm.

Procedure: Select [Main menu] >> [Config & Calib] >> [Diag parameters] >> [0% Tvl Error] >> [Alarm enable].

Select the Enable/Disable of alarm and press F4.

6. Shut-Off Cnt (Shut-Off Count)

Shut-Off Cnt is a count of valve shut.

Threshold

When Shut-Off Cnt becomes bigger than this value, alarm is sent.

Procedure: Select [Main menu] >> [Config & Calib] >> [Diag parameters] >> [Shut-Off Cnt] >> [Threshold].

Enter the threshold and press F4.

Alarm enable

Select the Enable / Disable of alarm.

Procedure: Select [Main menu] >> [Config & Calib] >> [Diag parameters] >> [Shut-Off Cnt] >> [Alarm enable].

Select the Enable/Disable of alarm and press F4.

Shut-Off Cnt

Procedure: Select [Main menu] >> [Config & Calib] >> [Diag parameters] >> [Shut-Off Cnt] >> [Shut-Off Cnt].

7. Max. Tvl Speed (Maximum Travel Speed)

Max. Tvl Speed is maximum valve travel speed in unit time.

Threshold

When Max. Tvl Speed becomes bigger than this value, alarm is sent.

Procedure:

Threshold +

Select [Main menu] >> [Config & Calib] >> [Diag parameters]
>> [Max Tvl Speed] >> [Threshold +]

Enter the Threshold + and press F4.

Threshold -

Select [Main menu] >> [Config & Calib] >> [Diag parameters]
>> [Max Tvl Speed] >> [Threshold -].

Enter the [Threshold -] and press F4.

Alarm enable

Select the Enable/Disable of alarm.

Procedure: Select [Main menu] >> [Config & Calib] >> [Diag parameters]
>> [Max Tvl Speed] >> [Alarm enable].

Select the Enable/Disable of alarm and press F4.

Max Tvl Speed (Maximum Travel Speed)

Procedure

Max. Tvl Speed +

Select [Main menu] >> [Config & Calib] >> [Diag parameters]
>> [Max tvl speed] >> [Max Tvl Speed +].

Max. Tvl Speed -

Select [Main menu] >> [Config & Calib] >> [Diag parameters]
>> [Max tvl speed] >> [Max Tvl Speed -].

Data clear

Max. Tvl Speed is cleared.

Procedure: Select [Main menu] >> [Config & Calib] >> [Diag parameters]
>> [Max Tvl Speed] >> [Data clear] and press F4.

8. Deviation Alarm

Deviation alarm is alarm of deviation with control signal input and valve travel.

Threshold

When the travel deviation becomes bigger than this value, alarm is sent.

Procedure

Threshold +

Select [Main menu] >> [Config & Calib] >> [Diag parameters] >> [Deviation Alarm] >> [Threshold +].

Enter the Threshold + and press F4.

Threshold -

Select [Main menu] >> [Config & Calib] >> [Diag parameters] >> [Deviation Alarm] >> [Threshold -].

Enter the Threshold - and press F4.

Waiting Time

When the valve travel error continues for a longer time than this waiting time, alarm is sent.

Procedure: Select [Main menu] >> [Config & Calib] >> [Diag parameters] >> [Deviation Alarm] >> [Waiting time].

Enter the Waiting time and press F4.

Alarm enable

Select the enable/Disable of alarm.

Procedure: Select [Main menu] >> [Config & Calib] >> [Diag parameters] >> [Deviation Alarm] >> [Alarm enable].

Select the Enable/Disable of alarm and press F4.

Deviation

Procedure: Select [Main menu] >> [Config & Calib] >> [Diag parameters] >> [Deviation Alarm] >> [Deviation].

9. Temp Alarm (Temperature alarm)

Temp Alarm is alarm of abnormal environmental temperature.

Threshold

When the temperature becomes bigger than this value, alarm is sent.

Procedure

Threshold +

Select [Main menu] >> [Config & Calib] >> [Diag parameters] >> [Temp Alarm] >> [Threshold +].

Enter the Threshold + and press F4.

Threshold -

Select [Main menu] >> [Config & Calib] >> [Diag parameters] >> [Temp Alarm] >> [Threshold]-.

Enter the threshold and press F4.

Waiting Time

When the temperature error continues for a longer time than this waiting time, alarm is sent.

Procedure: Select [Main menu] >> [Config & Calib] >> [Diag parameters] >> [Temp Alarm] >> [Waiting time].

Enter the Waiting time and press F4.

Alarm enable

Select the enable/Disable of alarm.

Procedure: Select [Main menu] >> [Config & Calib] >> [Diag parameters] >> [Temp Alarm] >> [Alarm enable].

Select the Enable/Disable of alarm and press F4.

Temperature

Procedure: Select [Main menu] >> [Config & Calib] >> [Diag parameters] >> [Temp Alarm] >> [Temperature].

Burst mode

Burst mode enab

Select the enable/Disable of burst mode.

Procedure: Select [Main menu] >> [Config & Calib] >> Burst mode >> [Burst mode enab].

Select the Enable/Disable of burst mode and press F4.

Burst command

Displays the method of Burst mode.

Procedure: Select [Main menu] >> [Config & Calib] >> [Burst mode] >> [Burst command].

(Burst command is stationary with 3.)

5-6: Initial setup

Auto setup

The following auto setup items are performed.

- Zero and span adjustment
- Actuator direction setting
- Input signal LRV and URV setting
- Actuator size selection
- Hysteresis setting
- Position transmission burnout direction selection

WARNING

Performing the auto setup operation is dangerous because the valve moves rapidly from the fully closed position to the fully open position. Prepare yourself and the process in advance so that no one is injured and the process is not adversely affected when the valve operates.

~Note *When a model VR actuator is used, set the actuator size to one of PARAM7 to PARAM9 before performing an auto setup operation. (See “Valve sys config (Valve system configuration)” on page 5-11.)*

Do not lower the input signal (4-20 mA) to a level less than 4 mA. (The level of the signal can be set to any level in the 4-20 mA range without problem.)

The operation has completed when after the actuator has followed the input signal and the system has returned to the control state.

After the operation completes, hold the input signal at a level above 4 mA for 30 seconds to write the settings.

There are cases where the dynamic characteristics may not be set correctly due to the size of the actuator (when the actuator is smaller than the Yamatake model HA1 actuator (diaphragm chamber capacity: 850 cm³)) or the operating stroke (when the stroke is less than 14.3 mm).

In these cases, refer to “Gap PID param (Gap PID parameters)” on page 13.

After the auto setup operation completes, vary the input signal manually and verify that the actuator moves to the corresponding position. If the span position is displaced, adjust the span.

Procedure

- Select [Main menu] >> [Initial setup] >> [Auto setup].
- When the confirmation message is displayed, press F4.
- When the execution confirmation message is displayed, press F4.
- When the auto setup completed message is displayed 2 or 3 minutes later, press F4.

5-7: Maintenance

Dummy input sig (Dummy input signal)

This function uses the SFC to set the input signal value regardless of the value of the input signal from the controller.

This function can be effective, for example, in isolating problems during troubleshooting. For example, if the control valve does not move in response to input signals from the controller, if the valve operates correctly in response to the simulated current input, then one can conclude that the problem is somewhere from the wiring to the host system.

Procedure

- Select [Main menu] >> [Maintenance] >> [Dummy input sig].
- When the confirmation message is displayed, press F4.
- Select the simulated input signal (0%, 50%, 100%, or Other) and press F4.
- If you selected Other, enter an arbitrary value (0 to 100%) and press F4.

Cancellation procedure

- Select [Main menu] >> Maintenance >> Dummy input sig
- When the confirmation message is displayed, press F4.
- Select Clear from the Dummy input sig menu and press F4.

Dummy drive sig (Dummy drive signal)

- Normally, this function is not used.
- This function cuts the drive signal from the PID control unit block, and sets the simulated drive signal to the EPM (electro-pneumatic converter module).

Procedure

- Select [Main menu] >> Maintenance >> Dummy input sig.
- When the confirmation message is displayed, press F4.
- Select the EPM simulated input percentage (0%, 50%, 100%, or Other) and press F4.
- If you selected Other, enter an arbitrary value (0 to 100%) and press F4.

Cancellation procedure

- Select [Main menu] >> [Maintenance] >> [Dummy input sig].
- When the confirmation message is displayed, press F4.
- Select Clear from the Dummy input signal menu and press F4.

User data save

- Saves all of the SVP internal data in place of the factory shipment data specifications (data set according to the model number).
- Use the “Recall Factory Data” operation to recall the saved data.
- We recommend saving the settings data after installing the SVP and after all settings have been completed.

~Note *All the factory shipment data is lost.*

When the data is written, the settings data is written to the SVP internal nonvolatile memory that is used for normal operation. This means that this data will not be lost even if the SVP power is turned off. This operation copies the contents of the memory used for normal operation to storage memory.

If a communications error occurs during communication (during storing), the data will not be stored. Repeat the store operation if this occurs.

Procedure

- Select [Main menu] >> [Maintenance] >> [User data save].
- When the confirm overwrite message is displayed, press F4.
- When the confirm update message is displayed, press F4.
- When the update completed message is displayed, press F4.

Correct reset

- This operation returns all the SVP internal data to the default (initial values) state.
- See the “Internal Data Default Values Table” for more information on default data (initial values).

~Note *Since use of this function will require that the SVP be adjusted and set up again, this function should not be used by anyone other than Yamatake service personnel.*

After recalling the data, start using the SVP from the starting communication step.

If a communication error occurs during communication (or during initialization), the initialization operation will not be performed. Perform the initialization operation again if this happens.

Procedure

- Select [Main menu] >> [Maintenance] >> [Correct reset].
- When the confirm overwrite message is displayed, press F4.
- When the confirm update message is displayed, press F4.
- When the update completed message is displayed, press F4.

5-8: Device status

This equipment includes a self diagnostics function. This function is convenient for troubleshooting.

See “Chapter 7: Troubleshooting”, for the appropriate actions to take for the different messages.

Failures

Procedure

- Select [Device status] >> [Failures].
- One of the following messages will be displayed if a fault was discovered.
 - No failure found
 - LOW IIN / Input signal too low
 - VTD FAULT / Valve travel detector error
 - A/D FAULT / A/D conversion module error
 - NVM FAULT / Non-volatile memory error
 - RAM FAULT / RAM error
 - ROM FAULT / ROM error

Notices

Procedure

- Select [Device status] >> [Notices].
- One of the following messages will be displayed if a fault was discovered.
 - No failure found
 - SHUT ON / SVP is forced fully shut-off
 - HI/LO EPM OUT / Electro-pneumatic module is outside normal
 - EXT ZERO ACTIVE / External zero / span adjustment is being made
 - MANUAL MODE / Dummy input signal operation
 - FIXED EPM OUT / Dummy drive signal operation
 - CORRECT RESET / Configuration data is reset at the time of shipment
 - OVER TEMP / Abnormal environmental temperature

Valve diagnostics

Alarms

Procedure

Select [Device status] >> [Valve diagnostics] >> [Alarms]

One of the following message will be displayed if a valve diagnostic alarm was discovered.

- No alarm found
- Stick Slip alarm
- Total Stroke alarm
- Cycle Count alarm
- Max Speed + alarm
- Max Speed - alarm
- 0% Tvl Err + alarm
- 0% Tvl Err - alarm
- Shut-Off Cnt alarm
- Deviation + alarm
- Deviation - alarm
- Temp Hi alarm
- Temp Lo alarm

Parameters status

Procedure

Select [Device status] >> [Parameters status].

Read the following valve diagnostic parameters

- Stick Slip
- Total Stroke
- Cycle Count
- Tvl Histogram
- Shut-Off Cut
- Max. Tvl Speed
- Deviation

Chapter 6 : Maintenance

6-1: Auto/Manual selection switch

The Auto/Manual switch selects the control method for the pneumatic output from the positioner to be either automatic operation or manual operation. See Figure 6-1 Structure of the A/M Switch.

Automatic operation

- An air pressure output corresponding to the input signal is output from the SVP.

Manual operation

- The supplied air pressure is output directly from the positioner.
- This allows manual operation using a pressure regulator.

⚠ CAUTION

The double acting actuator has no manual operation function.

⚠ WARNING

The valve may move suddenly when the A/M switch is operated. Prepare yourself and the process in advance so that the process is not adversely affected when the valve operates.

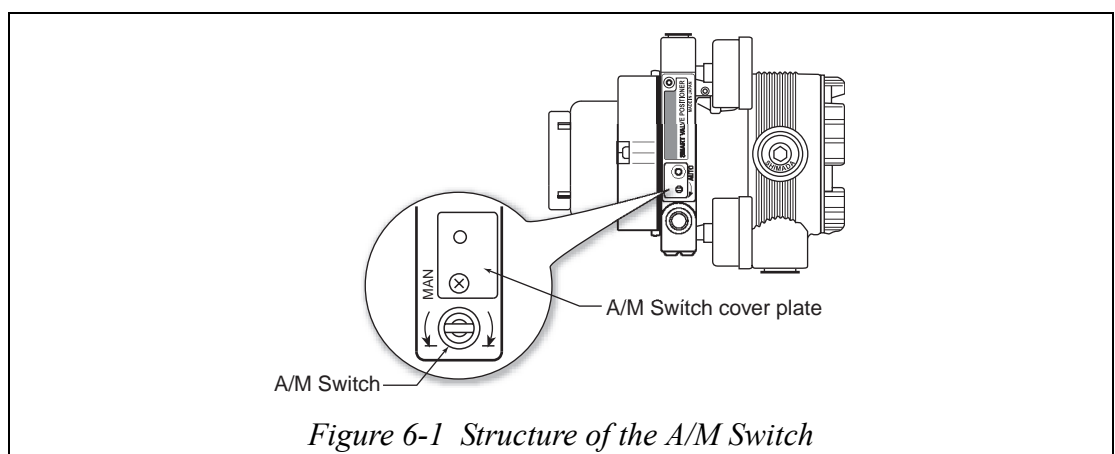

Procedure to change from automatic operation to manual operation

The change procedure from automatic operation to manual operation is shown below.

Step	Procedure
1	Open the A/M switch cover plate by rotating it 180 degrees to clockwise direction by hand. (You can rotate the cover plate easily if you press on the upper left of the cover plate while turning it.)
2	Rotate the A/M switch one turn to counter-clockwise direction (MAN direction) by using flat-bladed screwdriver. Be sure whether output pressure suddenly change.

Procedure to change from manual operation to automatic operation

The change procedure from manual operation to automatic operation is shown below.

Step	Procedure
1	Rotate the A/M switch fully shut position to clockwise direction (AUTO direction) by using flat-bladed screwdriver.
2	Close the A/M switch cover plate by rotating it 180 degrees to counter-clockwise direction by hand till it clicks.

~Note *Do not loosen the A/M switch cover plate screw.*

6-2: Filter replacement and restriction maintenance

The contamination from the instrumentation air that collects in the restriction in the SVP can be removed during maintenance. For the instrumentation air, use dry air which has been cleaned of 3 μm (or smaller) solid particles. Always use a Phillips screwdriver.

Procedure

Step	Procedure
1	Cut off the air supply to the SVP.
2	Remove the setscrews from the A/M switch nameplate section. <i>~Note Be careful not to drop the A/M switch cover plate washers and corrugated washers when removing the screws.</i>
3	Turn the A/M switch to the MAN (manual) position.
4	Use nippers or another tool to cut the holder and remove the old filter. <i>~Note Dispose of the old holder and filter appropriately.</i>
5	Use wire to remove the contamination from the restriction (diameter 0.3 mm). <i>~Note Be careful not to damage the restriction when removing the contamination. Do not use an air gun. Do not allow any oils or greases to contaminate the restriction.</i>
6	Wrap a new filter around the A/M switch, and press it in place with the holder.
7	Screw down the A/M switch until it stops.
8	Reassemble the A/M switch section name plate together with the A/M switch cover plate using the setscrews.

6-3: Cleaning the flapper

If contamination from the instrumentation air has accumulated on the flapper, clean the flapper as described below.

CAUTION

If air pressure is supplied to the SVP, the nozzle back pressure may change causing the valve position may change suddenly when the flapper is cleaned. Only clean the flapper in a state where no one will be injured and plant operation will not be adversely influenced even if the valve moves suddenly.

Procedure

Step	Procedure
1	Remove the three pilot cover screws.
2	Provide scraps of paper with a thickness of 0.2 mm. Common business cards are appropriate.
3	Use the scraps of paper to clean the contamination from the gap between the EPM nozzle and the flapper.
4	After cleaning the gap, reassemble the pilot cover onto the main unit.

6-4: EPM (Electro-pneumatic Converter Module) balance adjustment

In situations such as when excessive mechanical shocks and other external disturbances have been applied to the SVP itself, or when contamination from the instrumentation air has collected in the nozzle flapper area, the internal EPM (electro-pneumatic converter module) balance point may be displaced and the response characteristics degraded. This can lead to malfunctions occurring. If the balance point displacement cannot be rectified by cleaning the nozzle flapper area, EPM adjustment will be necessary.

CAUTION

The EPM balance adjustment can cause the valve position to change rapidly. Only perform this adjustment in a state where no one will be injured and plant operation will not be adversely influenced even if the valve moves suddenly.

Procedure

Step	Procedure
1	Remove the three pilot cover screws.
2	After supplying the stipulated air pressure, set the input signal to 50%.
3	Observe the EPM drive signal using the SFC. (Refer to “Verifying the EPM (Electro-Pneumatic converter Module) drive signals [SVT]” on page 46)
4	Adjust the EPM drive signal to have a $50\% \pm 5\%$ duty by turning the EPM adjustment screw.

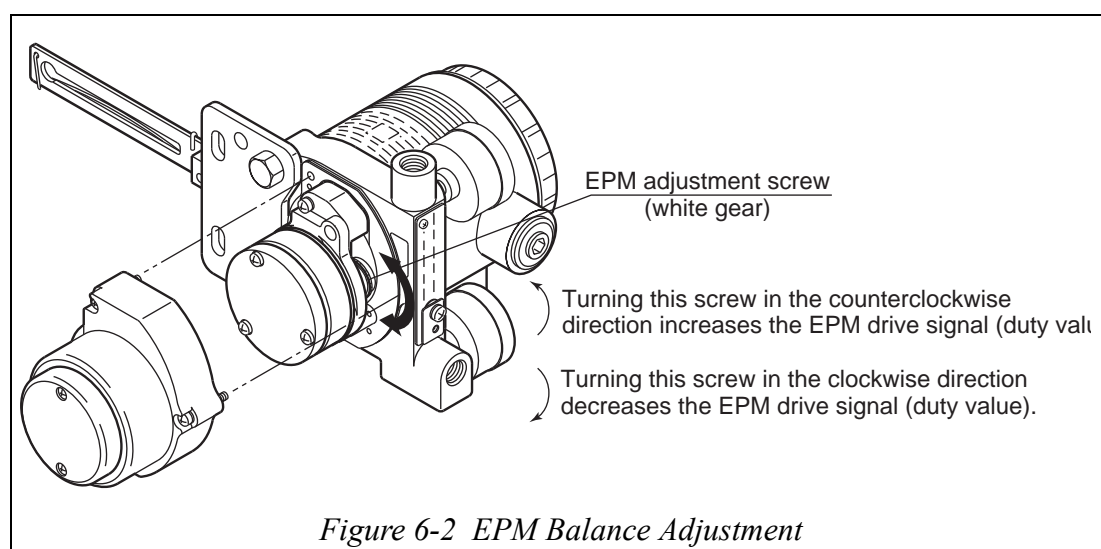

6-5: Insulation Resistance Test

CAUTION

As a general rule, please do not perform the insulation resistance test. Performing this test may result in damage to the varistor for absorbing internal surge voltage.
If you absolutely must perform the test, please perform it carefully in accordance with the designated procedures.

Test procedures

- Disconnect the device's external wiring.
- Short circuit the + and - terminals of the input and output respectively.
- Perform the tests between ground terminal and its respective short-circuit between the + and - terminals.
- Applied voltage and judgment standards are as follows. To avoid damage to the instrument, do not apply voltage greater than the values listed below.

Judgment criteria

The judgment standard for the test is as follows:

Test	Judgment Standard
Insulation Resistance Test	More than 20 MΩ at test voltage 25V DC (25°C, under 60% RH)

6-6: Adjustment procedure when using the SVP attached to the booster relay

When using the device attached to the booster relay, please adjust using the following procedure:

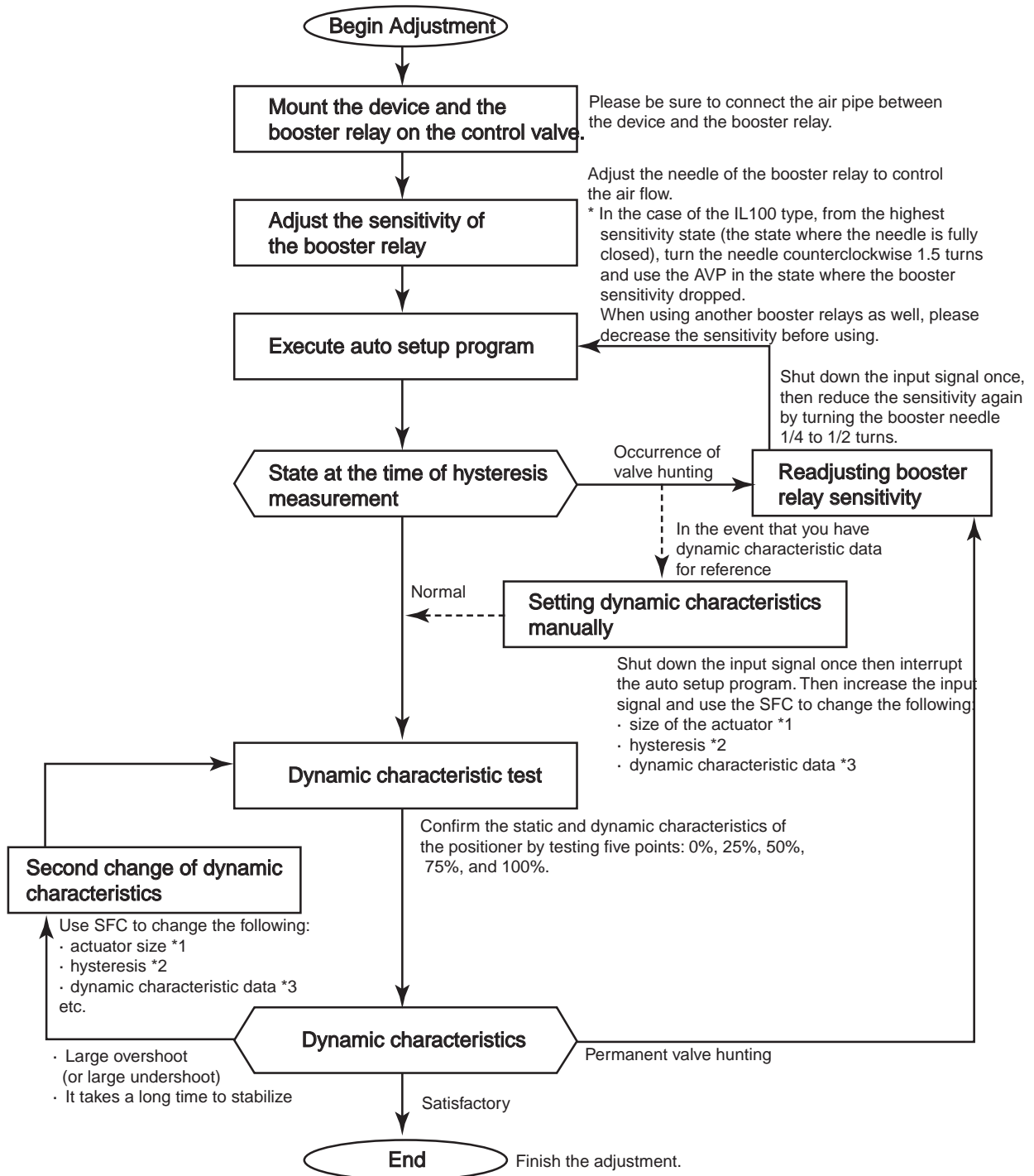

- ~Note**
- *1: Change the actuator size parameter from 6 to 5, 5 to 4, etc. in decreasing numerical order.
 - *2: Change the hysteresis parameters in order from light to medium and medium to heavy.
 - *3: Reduce P, GP, reduce I, GI, increase D, GD, etc.

6-7: Table of default internal data values

Item		Default value
Tag number		XXXXXXXX
Output format		ANALOG XMTR
Burnout direction		DOWN SCALE
Actuator operation		REVERSE
Positioner operation		DIRECT
Valve operation		DIRECT
Actuator size		PARAM 1
Hysteresis		HEAVY
PID parameters (parameter 0)	P	1.200
	I	4.000
	D	0.5000
	GE	+/-0.000%
	GP	0.7000
	GI	4.000
	GD	0.5000
Flow characteristics		LINEAR
User defined flow characteristics data		(Pressure balance type adjustment valve (ADVB/ADVM) linear characteristics data)
Valve fully closed value (LRV)		4.000mA
Valve fully open value (URV)		20.00mA
Forced fully closed input value		0.5000%IIN
Forced fully open input value		109.00%IIN
Digital output settings	Output signal mode	Single Range
	Amount of data mode	DE-4Byte
	Failsafe mode	F/S=B/O Hi

6-8: SVP internal block diagram and SVP I/O flow

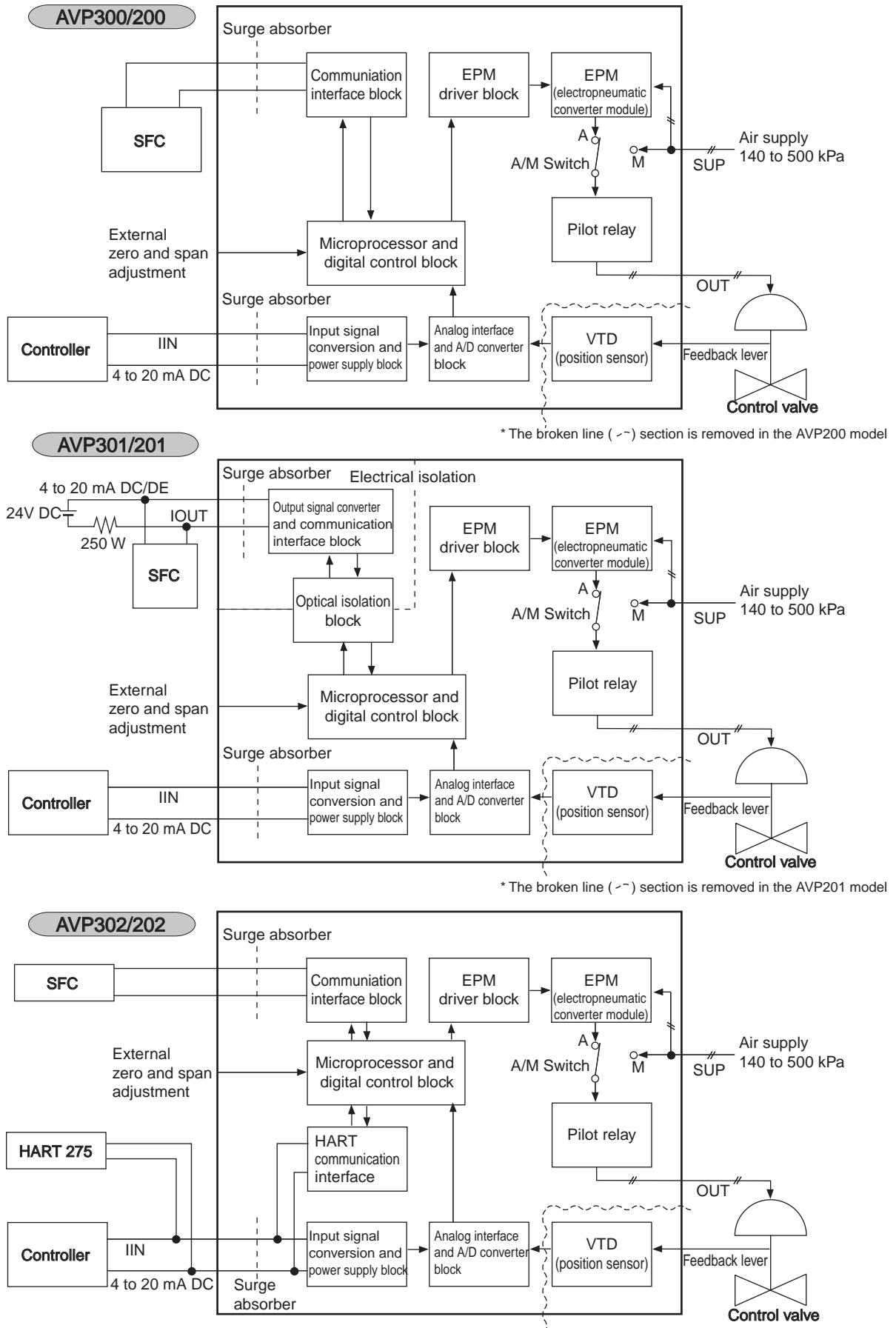

Figure 6-3 SVP block diagram

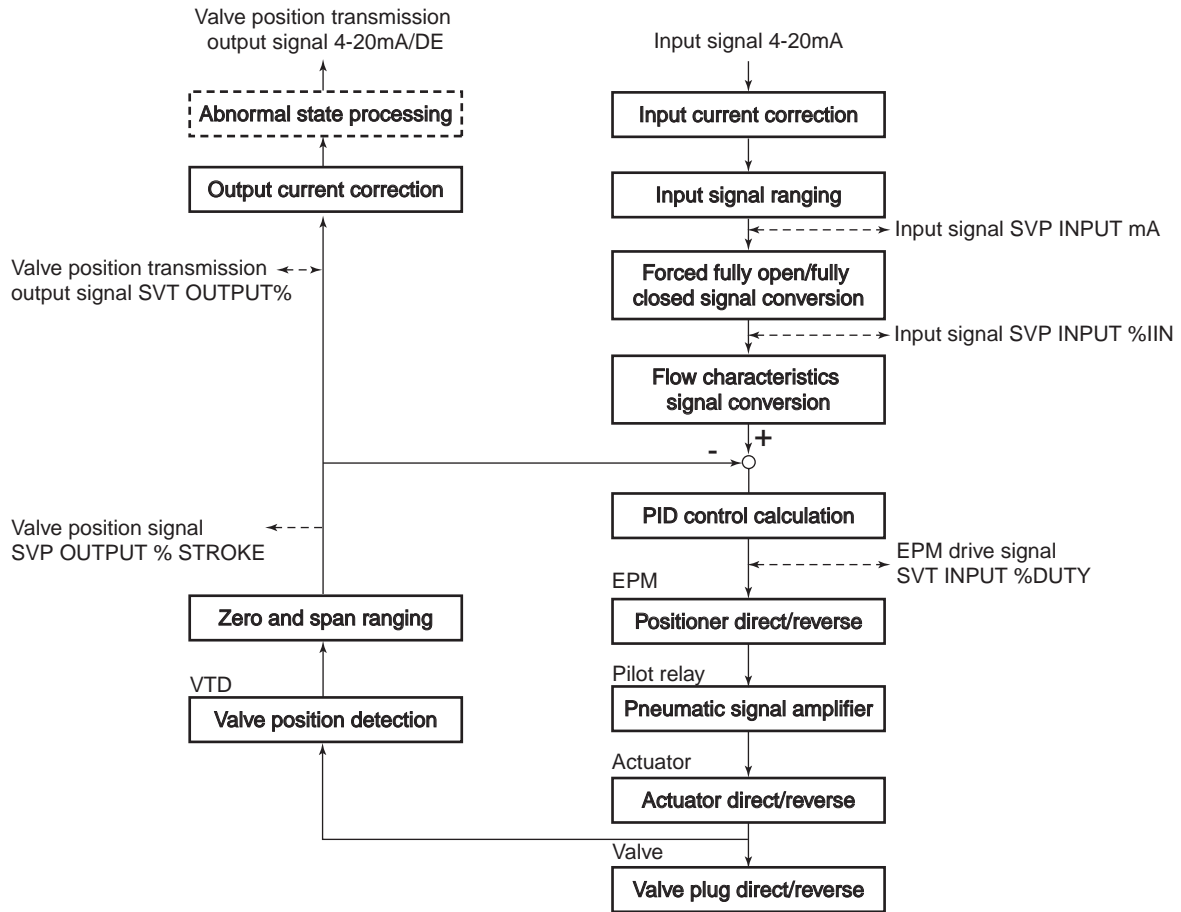

Figure 6-4 SVP I/O flow

6-9: Replacement parts

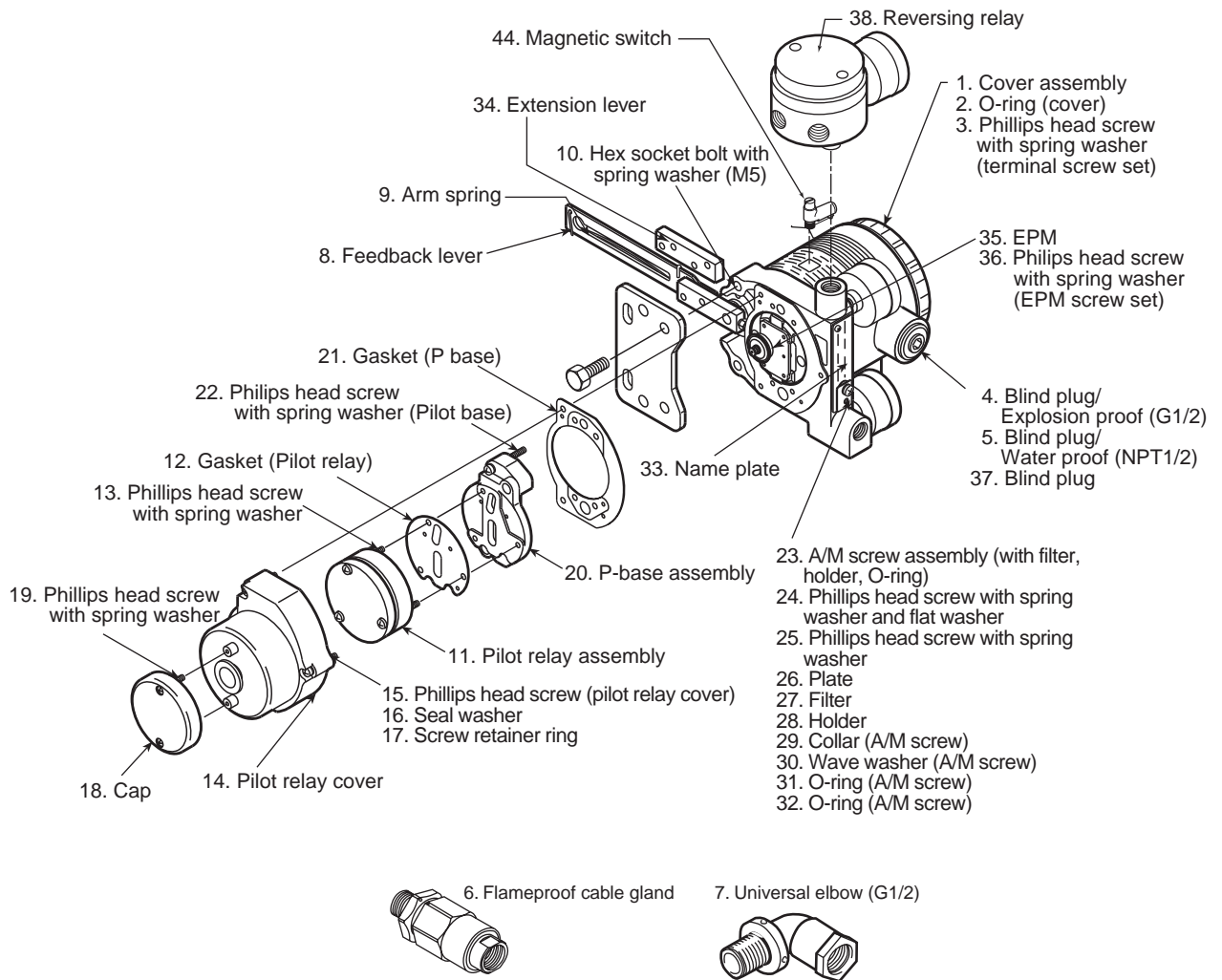

Figure 6-5 Replacement parts

No.	Parts	Parts number	Qty	Recommended replacement cycle	
1	Cover assembly	Standard finish	80377007-001	1	—
		Corrosion proof	80377007-002		
		Silver finish	80377007-003		
2	O-ring (cover)	80020935-845	1	5 years	
3	Phillips head screw with spring washer (terminal screw set)	80277581-001	5	—	
4	Blind plug/Explosion proof (G1/2)	80377115-001	1	—	
5	Blind plug/Waterproof (NPT1/2)	80277971-001	1	—	
6	Flameproof cable gland (for input signal cable conduit of model AVP300/301/302 before July. 2003)	80343903-003	1	—	
	Flameproof cable gland (for input signal cable conduit of model AVP200/201/202 before July. 2003)	80377547-003	1	—	
	Flameproof cable gland (for input signal cable conduit of model AVP300/301/302/200/201/202 after August. 2003)	80377921-003	1	—	
	Flameproof cable gland (for remote cable conduit of model AVP200/201/202 before December. 2003)	80377547-002	1	—	
	Flameproof cable gland (for remote cable conduit of model AVP200/201/202 after January. 2004)	80377921-002	1	—	

No.	Parts	Parts number	Qty	Recommended replacement cycle	
7	Universal elbow	80357206-107	1	—	
8	Feedback lever	80377121-001	1	—	
9	Arm spring	80377122-001	1	—	
10	Hex socket bolt with spring washer (M5)	80377127-001	2 (4)	—	
11	Pilot relay assembly	80377050-001	1	5 years	
12	Gasket (Pilot relay)	80377072-001	1	5 years	
13	Philip head screw with spring washer	398-204-300	3	—	
14	Pilot relay cover	Standard finish	80377064-001	1	—
		Corrosion proof	80377064-002		
		Silver finish	80377064-003		
15	Phillips head screw (Pilot relay cover)	398-204-250	3	—	
16	Seal washer	80357789-001	3	—	
17	Screw retainer ring	80235519-010	3	—	
18	Cap	Standard finish	80377066-001	1	—
		Corrosion proof	80377066-002		
		Silver finish	80377066-003		
19	Phillips head screw with spring washer	398-203-080	2	—	
20	P-base assembly	80377069-001	1	—	
21	Gasket (P-base)	80377068-001	1	5 years	
22	Phillips head screw with spring washer (Pilot base)	398-204-200	4	—	
23	A/M screw assembly (with Filter, Holder, O-ring)	80377074-001	1	4 years	
24	Phillips head screw with spring washer and flat washer	80277581-002	1	—	
25	Phillips head screw with spring washer	398-204-080	1	—	
26	Plate	80377089-001	1	—	
27	Filter	80377077-001	1	—	
28	Holder	80377078-001	1	4 years	
29	Collar (A/M screw)	80377088-001	1	—	
30	Wave washer (A/M screw)	80377073-001	1	—	
31	O-ring (A/M screw)	80020935-216	1	5 years	
32	O-ring (A/M screw)	80020935-313	2	5 years	
33	Name plate	80377079-001	1	—	
34	Extension lever	80377142-001	1	—	
35	EPM	Direct	80377010-001	1	—
		Reverse	80377010-002		
36	Phillips head screw with spring washer (EPM screw set)	80377046-001	2	—	
37	Being plug	80377205-001	1	—	
38	Reversing relay	Standard finish, Rc1/4	80377323-001	1	5 years
		Corrosion proof, Rc1/4	80377323-011		
		Silver finish, Rc1/4	80377323-021		
		Standard finish, 1/4NPT	80377323-002		
		Corrosion proof, 1/4NPT	80377323-012		
		Silver finish, 1/4NPT	80377323-022		
44	Magnetic switch	80377080-001	1	—	

Chapter 7: Troubleshooting

The SVP is a precision instrument and requires the same level of care as any other field device. Unlike an air-actuated control valve, the SVP contains many electronic components and mechanical parts which must have proper settings and calibration. Poor SVP performance is usually easy to correct by adjusting settings.

A Minor Failure indicates no immediate danger or serious trouble in the operation of the SVP. The SVP will continue to operate normally. Connecting an SFC or HART Communicator or requesting a self-diagnostic through the supervisory monitoring system (model AVP301/302/200/201/202) is necessary to discover and determine Minor Failures.

A Major Failure indicates serious trouble in the operation of the SVP and, if no action is taken, may lead to damage to the SVP itself. Should serious trouble occur during SVP operations, the SVP will drive the valve to the fail-safe position. An SFC or HART Communicator, or the supervisory monitoring system (model AVP301/302/200/201/202) are used to determine Major Failures.

7-1: Using an SFC

If you have an SFC connected to the SVP and a Hash (#) mark appears in the lower right corner of the screen, then an alarm condition exists.

To determine an error:

Step	Procedure
1	Make sure the SFC is in the Ready State.
2	Press the  key to see which error conditions exist. If there is more than one, then each error condition flashes for 3 seconds. The following page lists error conditions, as well as the SFC error code and text message that is returned for each error, and possible solutions.

7-2: Using a HART Communicator

If you have a HART Communicator connected to the SVP, you can perform a self-diagnostic:

Step	Procedure
1	Make sure the HART Communicator is in the Ready State.
2	Select [5. Device Status] >> [2. Failures] or [3. Notices].
3	If a message is displayed, see the following page for a list of error conditions as well as the HART error code and possible solutions.

If after reading this troubleshooting section and solutions, the specifications of the SVP still do not match your requirements, or the SVP fails, contact your local Yamatake representative.

7-3: General troubleshooting

If, after attaching your SVP to a control valve and performing Auto-Setup or manual calibration, you are experiencing performance problems, follow the troubleshooting steps below.

If the troubleshooting procedures below do not fix the problem, contact your Yamatake representative.

SVP does not operate (no output air pressure)

1. Confirm that the internal SVP settings for actuator size, hysteresis, etc. are appropriate for your control valve. For model AVP300/301/200/201, refer to “(A) Basic data settings (SYSTEM CONFIG)” on page 1. For model AVP302/202, refer to "5-2: Starting communication" on page 5-4.
2. Make sure that the SVP feedback lever is not exceeding a 20° angle of rotation. If it is, add an extension bracket to the feedback lever to provide the necessary feedback lever length.
3. Check for air leaks in air supply.
4. Check electrical input signals.
5. Check Auto/Manual switch in Auto.
6. Check the flapper and the filter clears.
7. If communication can be made with a SFC or HART Communicator, perform self diagnostics and take action based on errors messages. See “Troubleshooting Codes” on page 4.

Abnormal action of control valve (although output air is supplied, the control valve does not operate properly):

1. Change the A/M switch to manual (See page 1) and adjust the air pressure using the regulator valve from fully open to fully closed. Watch to see if valve stem moves smoothly. If it does not, this may indicate galling or hardening of the valve packing.
2. Confirm that the internal SVP settings for actuator size, hysteresis, etc. are appropriate for your control valve. For model AVP300/301/200/201, refer to “(A) Basic data settings (SYSTEM CONFIG)” on page 14. For model AVP302/202, refer to "5-2: Starting communication" on page 5-4.
3. Hunting, Overshoot
 - Change hysteresis setting from medium to heavy. If problem persists, set hysteresis at heavy and change the actuator size setting to smaller PRAM numbers.
 - Check permissible angle of rotation of feedback lever.
4. Absence of full stroke, slow response.
 - Check the zero (fully closed) and span (fully opened) are properly adjusted.
 - Check the EPM drive signals are within range of 50+/-25%.
 - Check the filter and the flapper clean

No communication possible with an SFC or HART Communicator:

1. Check input signal wiring. 4 mA is required for the SVP to operate.
2. Check that the SFC or HART Communicator and SVP are wired properly. For model AVP300/301/200/201, refer to "4-3: Connecting the SFC" on page 4-4. For model AVP302/202, refer to "5-2: Starting communication" on page 5-4.
3. If the SFC or HART Communicator will not power on, check the batteries.

Troubleshooting Codes

Message	Cause	Correction
LO IIN	Input signal is too low (3.8 mA or lower).	Provide an input signal of at least 3.8 mA.
VTD FAULT	(Valve position sensor) Feedback lever has fallen off or has turned beyond the allowable turning angle (+/-20°C)	Check if feedback lever has fallen off and that it is within permissible turning angle.
A/D FAULT	(Analog/Digital conversion)	Contact YAMATAKE.
NVM FAULT	(Non-Volatile Memory)	Contact YAMATAKE.
RAM FAULT	(RAM error)	Contact YAMATAKE.
ROM FAULT	(ROM error)	Contact YAMATAKE.
SHUT ON	SVP is forced fully closed	Apply an input signal above the forced fully shut value. Use the SFC to check and/or adjust the forced fully open/close values (%).
HI/LO EPM OUT	Electro-pneumatic Module is outside normal range No air is being supplied Valve is closed Galling of valve stem Clogged nozzle Clogged orifice	Check air supply pressure Confirm A/M switch is Auto Clean air nozzle Clean orifice Adjust the EPM balance
EXT ZERO ACTIVE	External Zero-span adjustment is being made.	Release the external Zero-span adjustment screw.
MANUAL MODE	Dummy input signal from SFC/HART.	Cancel the dummy current input.
FIXED EPM OUT	Dummy EPM pseudo-drive signal from SFC/HART.	Cancel the dummy EPM signal.
OUTPUT MODE	Dummy pseudo-signal output state for SFC/HART.	Cancel the dummy output.
CORRECT RESET	Data was reset at the time of shipment.	Set actuator type and other parameters before use.
OVER TEMP	Abnormal Temperature within SVP unit.	Check SVP temp and move it to a cooler location.

SFC message documentation (Communication and SFC problems)

Message	Cause	Correction
COMM ABORTED	During communication, the [CLR] key was pressed, canceling the communication.	
FAILED COMM CHK	Displays the error that occurred during communication.	
LOW LOOP RES	The loop resistance does not exceed 250Ω.	Check the resistance. If it is too low, insert addition resistors so that the resistance is over 250Ω.
HI RES/LO VOLT	Either the loop resistance is too high or the supply voltage is too low.	Check the wiring and the power supply.
XMTR RESPONSE	There was no response from the SVP in response to a request from the SFC.	Check the wiring and the power supply. Verify that the SFC communication cable is connected correctly.
ILLEGAL RESPONSE	The SFC was not able to interpret the response from the SVP.	Check the wiring.
NACK RESPONSE	There was an error in the data received by the SVP.	Check the wiring.
END AROUND ERR	There was an error in the data received by the SFC.	Check the wiring.
UNKNOWN DIGITAL	A communication error occurred during digital communication.	Retry the communication operation.
XMTR IS BUSY	The SVP is executing special processing.	Retry the communication operation.
STATUS UNKNOWN	There was no response from the SVP, and the status is unknown.	Check the wiring and the power supply.
SFI UNKNOWN	It was not possible to identify the type of the transmitter.	Turn off the SFC power and then turn it back on again. Verify that the tag on the bottom of the SFC identifies it as either model SFC160 or model SFC260.
CLOCK FAIL!	The internal SFC clock failed.	Contact your Yamatake representative.
PRINTER FAIL!	The printer failed.	Contact your Yamatake representative.
SFC RAM FAILURE	The SFC RAM failed.	Contact your Yamatake representative.

Document Number:	CM2-AVP300-2001
Document Name:	SVP3000 Alphaplus Smart Valve Positioner Model: AVP300/301/302/200/201/202 User's Manual
Date:	Oct. 1998 (First issue) Dec. 2005 (Rev. 10)
Issued/Edited by:	Yamatake Corporation

Yamatake Corporation
Advanced Automation Company

1-1-32 New Stage Yokohama, Shin-urashima-cho,
Kanagawa-ku, Yokohama, Kanagawa-ken 221-0031, Japan
Tel : +81-45-461-8631
Fax : +81-45-461-2658

YAMATAKE
Savemation
Saving through Automation