

PREX 3000 Vector Involute Type Pneumatic Differential Pressure Transmitters Model KDP61/62 (Flange Type)



The PREX3000 instruments are pneumatic type transmitters which employ a combination of vector balance mechanism and involute mechanism.

The instruments are featured by high resistance against adverse environments, high turn-down ratio, high accuracy, and ease of maintenance.

Standard Specifications

Item	Specifications						
Measuring range (continuously adjustable)	KDP 61: 0-25 to 0-500 kPa {0-2,500 to 0-50,000 mmH ₂ O} KDP 62: 0-2.5 to 0-53.9 kPa {0-250 to 0-5,500 mmH ₂ O}						
Process connection	Measuring side (liquid level): Flange connection <table style="margin-left: 20px; border-left: 1px solid black; border-right: 1px solid black;"> <tr> <td style="padding-left: 5px;">Flush diaphragm type</td> </tr> <tr> <td style="padding-left: 15px;">80 mm-JIS 10K, 30K (RF) equivalent flange</td> </tr> <tr> <td style="padding-left: 15px;">3"-ANSI 150, 300 (RF) equivalent flange</td> </tr> <tr> <td style="padding-left: 5px;">Extended diaphragm type</td> </tr> <tr> <td style="padding-left: 15px;">100 mm-JIS 10K, 30K (RF) equivalent flange</td> </tr> <tr> <td style="padding-left: 15px;">4"-ANSI 150, 300 (RF) equivalent flange</td> </tr> </table> Reference side: Rc 1/2 or 1/2 NPT internal thread	Flush diaphragm type	80 mm-JIS 10K, 30K (RF) equivalent flange	3"-ANSI 150, 300 (RF) equivalent flange	Extended diaphragm type	100 mm-JIS 10K, 30K (RF) equivalent flange	4"-ANSI 150, 300 (RF) equivalent flange
Flush diaphragm type							
80 mm-JIS 10K, 30K (RF) equivalent flange							
3"-ANSI 150, 300 (RF) equivalent flange							
Extended diaphragm type							
100 mm-JIS 10K, 30K (RF) equivalent flange							
4"-ANSI 150, 300 (RF) equivalent flange							
Air supply connection	Rc 1/4 or 1/4 NPT internal thread						
Air supply pressure	140±14 kPa {1.4±0.14 kgf/cm ² }						
Output	20-100 kPa {0.2-1.0 kgf/cm ² }						
External load	ID 4 mm × Length 3 m+20 cm ³ or over						
Air supply capacity	20Nℓ/minute or over, with 6.7 kPa {50 mmHg} change						
Air consumption	5Nℓ/minute or less (when balanced at output 100%)						
Accuracy	KDP 61: ±0.5% FS (for spans 0-50 to 0-500 kPa {0-5,000 to 0-50,000 mmH ₂ O}) ±1.0% FS (for spans 0-25 to 0-less than 50 kPa {0-2,500 to 0-Less than 5,000 mmH ₂ O}) KDP 62: ±0.5% FS (for spans 0-5 to 0-53.9 kPa {0-500 to 0-5,500 mmH ₂ O}) ±1.0% FS (for spans 0-2.5 to 0-less than 5 kPa {0-250 to 0-Less than 500 mmH ₂ O})						
Dead band	0.1% FS						
Working pressure	-50 kPa {-0.5 kgf/cm ² } to maximum flange rated pressure, (differs by material of cover) [refer to Fig. 1, 4]						
Operating temperature	Meter body (process fluid): -40 to +120°C Transmitter (ambient): -30 to +80°C						
Operating humidity	10 to 90% RH [refer to Fig. 1]						
Overload protection	Up to maximum flange rated pressure in either direction.						
Construction	Dustproof and waterproof, meets IEC IP54, NEMA Type 3R, JIS F8001 Class 3 splashproof, JIS C0920 rainproof						

Item	Specifications
Materials	Center body: SUS304 Wetted parts of flange side and those of center body: SUS316 (diaphragm: SUS316L), SUS316L, Monel, Tantalum Meter body cover: Reference side: Carbon steel (SF45A), SUS316, Monel, PVC (reinforced with SUS304 plates, working pressure range: -0.01 to 1.5 MPa {-0.1 to +15 kgf/cm ² } operating temperature range: 0 to 55°C) Measuring side: Carbon steel (SF45A), SUS304 Flange: Carbon steel (SF45A), SUS304 Gasket (reference pressure side): Teflon Transmitter case: Aluminium alloy
Finish	Acryl baking finish Color: Light beige (munsell 4Y 7.2/1.3)
Mounting	Directly flange mounted to process flange.
Net weight	Approx. 13 kg (80 mm-JIS 10K flange, add 0.8 kg for air-set)

Optional Specifications

Item	Specifications												
(1) Suppression and elevation	(unit: kPa {mmH ₂ O}) <table border="1"> <thead> <tr> <th>Model No.</th> <th>Span</th> <th>Suppression (max.)</th> <th>Elevation (max.)</th> </tr> </thead> <tbody> <tr> <td>KDP 61</td> <td>25 to 500{2,500-50,000}</td> <td>500{50,000}</td> <td>475{47,500}</td> </tr> <tr> <td>KDP 62</td> <td>2.5 to 53.9{250-5,500}</td> <td>53.9{5,500}</td> <td>51.4{5,250}</td> </tr> </tbody> </table> (note: elevation+span ≤ maximum span, suppression ≤ maximum span)	Model No.	Span	Suppression (max.)	Elevation (max.)	KDP 61	25 to 500{2,500-50,000}	500{50,000}	475{47,500}	KDP 62	2.5 to 53.9{250-5,500}	53.9{5,500}	51.4{5,250}
Model No.	Span	Suppression (max.)	Elevation (max.)										
KDP 61	25 to 500{2,500-50,000}	500{50,000}	475{47,500}										
KDP 62	2.5 to 53.9{250-5,500}	53.9{5,500}	51.4{5,250}										
(2) Air-set (filter and pressure regulator)	Primary pressure: 200 to 990 kPa {2-9.9 kgf/cm ² } Secondary pressure: 140 kPa {1.4 kgf/cm ² } Filter mesh diameter: 5 microns Connections: Rc1/4 or 1/4NPT internal thread												

Optional Semi-standard Specifications

Item	Specifications
(1) For vacuum use (Y23)	Y169, Y182 and Y183 are not available for Y23. [refer to Fig. 3, 4]
(2) SUS304 bolts for meter body clamping (Y66)	Maximum working pressure: Carbon steel, SUS316, or Monel cover: 6 MPa {60 kgf/cm ² } PVC cover: 1.5 MPa {15 kgf/cm ² }
(3) Corrosion-resistant and silver finish (Y138)	Corrosion resistant (acryl baking) finish (Y138A): Resistant against corrosive gases. Corrosionproof (epoxy baking) finish (Y138B): Resistant against corrosive liquids. Silver-normal (acryl baking) finish (Y138C): To prevent temperature rise of instrument caused by direct sunlight or radiation from other source of heat. Silver-corrosion-resistant (acryl baking) finish (Y138D): To prevent temperature rise the same as above, plus resistance against corrosive gases (Note: Silver finish is not applicable for alkaline gases)
(4) Damping adjustment (Y169) (continuously adjustable)	Time constant: Minimum 3 sec. or less, Maximum 15 sec. or over (when KDP61 is incorporated with Y182 or Y183, the minimum time constant is 0.5 sec. or less and the maximum time constant is 3 sec. or more)
(5) For oxygen measurement (Y182)	Measuring element material: SUS316 or SUS316L Liquid fill: Fluorine oil (specific gravity: 1.915 at 25°C) Operating temperature (fluid and ambient temperature): -10 to +60°C Wetted parts treatment: Treated for degreasing [refer to Fig. 2, 4]
(6) For chlorine gas measurement (Y183)	Measuring element material: Tantalum Liquid fill: Fluorine oil (specific gravity: 1.915 at 25°C) Operating temperature (fluid and ambient temperature): -10 to +80°C Wetted parts treatment: Treated for degreasing [refer to Fig. 2, 4]
(7) Output pressure gauge (Y185)	Pressure gauge (100 mm diameter) 
(8) High vibration resistant type (Y188)	High vibration resistant type with dashpot.

Model Number Table

Ex: KDP62-1122100A1-5, 7

Basic Model No.	Flange & Cover Mat'l		Wetted Parts Mat'l		Flange Rating	Length of Extended Part of Flange	Air Piping Connection	Pressure unit / Output	Options	Description
	Measuring Side	Reference Side	Measuring Side	Reference Side						
KDP 61										0-25 to 0-500 kPa(0-2,500 to 0-50,000 mmH ₂ O)
KDP 62										0-2.5 to 0-53.9 kPa(0-250 to 0-5,500 mmH ₂ O)
	-1									Carbon steel (SF45A)
	-7									SUS304
			1							Carbon steel (SF45A)
			2							SUS316
			3							Monel
			5							PVC
				2						SUS316 (diaphragm: SUS316L)
				3						Monel (excluding extended diaphragm type)
				4						Tantalum (excluding extended diaphragm type)
				8						SUS316L
					2					SUS316 (diaphragm: SUS316L)
					3					Monel
					4					Tantalum
					8					SUS316L
					1					Flush diaphragm type 80mm-JIS10K (RF) equiv. flange
					2					Flush diaphragm type 80mm-JIS30K (RF) equiv. flange
					3					Flush diaphragm type 3"-ANSI150 (RF) equiv. flange
					4					Flush diaphragm type 3"-ANSI300 (RF) equiv. flange
					5					Extended diaphragm type 100mm-JIS10K (RF) equiv. flange
					6					Extended diaphragm type 100mm-JIS30K (RF) equiv. flange
					7					Extended diaphragm type 4"-ANSI150 (RF) equiv. flange
					8					Extended diaphragm type 4"-ANSI300 (RF) equiv. flange
						00				Flush diaphragm type
						10				Extended diaphragm type 100 mm
						15				Extended diaphragm type 150 mm
							A			Rc 1/4 internal thread
							B			1/4 NPT internal thread
								1		kgf/cm ² (or mmH ₂ O) / 0.2 to 1.0 kgf/cm ²
								2		PSI / 3 to 15 PSI
								3		bar / 0.2 to 1.0 bar
								4		Pa / 20 to 100 kPa
								8		Pa / 19.6 to 98.1 kPa (equality to 0.2 to 1.0 kgf/cm ²)
								-X		No option
								-5		Elevation
								-6		Suppression
								-7		Air-set

Note)
When ordering "Y" options, please write as:
KDP62Y-1122100A1-5,7 (Y □).

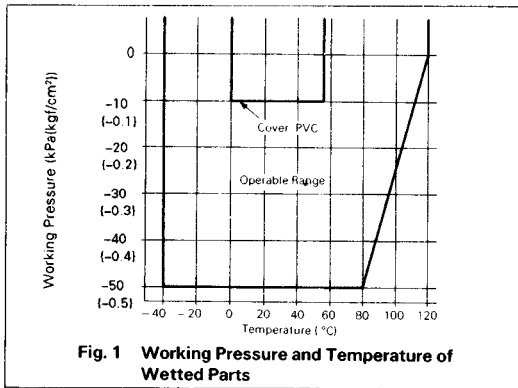

Fig. 1 Working Pressure and Temperature of Wetted Parts

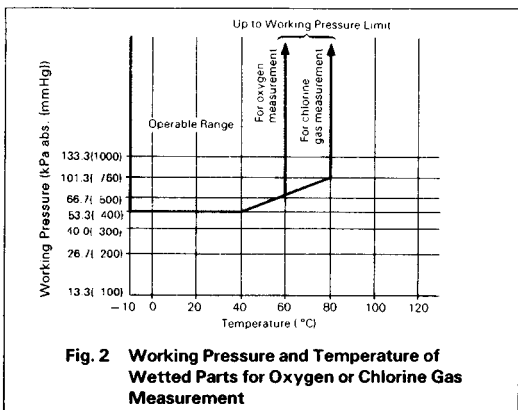

Fig. 2 Working Pressure and Temperature of Wetted Parts for Oxygen or Chlorine Gas Measurement

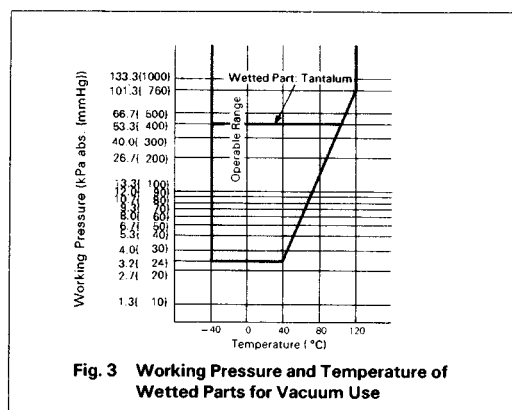

Fig. 3 Working Pressure and Temperature of Wetted Parts for Vacuum Use

Fig4. Max Working Pressure

Note1. Max Working Pressure depends on flange rating , flange materials and operating temperature. Please refer to the following data.

Operating range of temperature depends on specification of transmitters

Note2. In case of remote sealed type (KKP75,KFKB□□-75), Max Working Pressure depends on the smaller value of either 1.05MPa or following data.

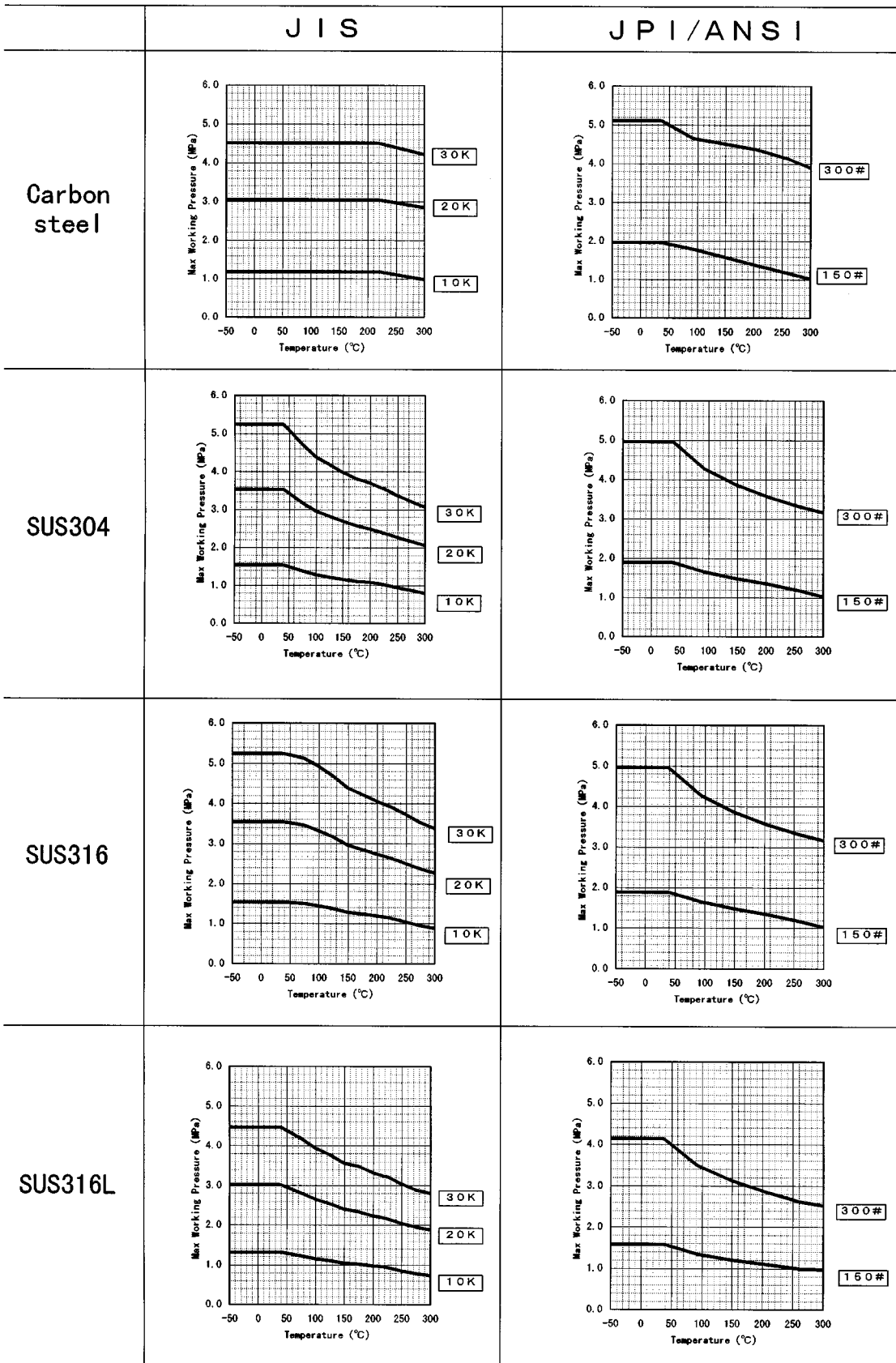

Dimensions

Flush Diaphragm Type

(Unit:mm)

Main Dimensions

ITEM	FLANGE RATING	A	B	X	Y
1	80 mm JIS 10K RF	280	114	190.5	211.5
2	80 mm JIS 30K RF	290	124	203	224
3, A	3" ANSI/JPI 150 RF	286	120	193.5	214.5
4, B	3" ANSI/JPI 300 RF	291	125	203	224

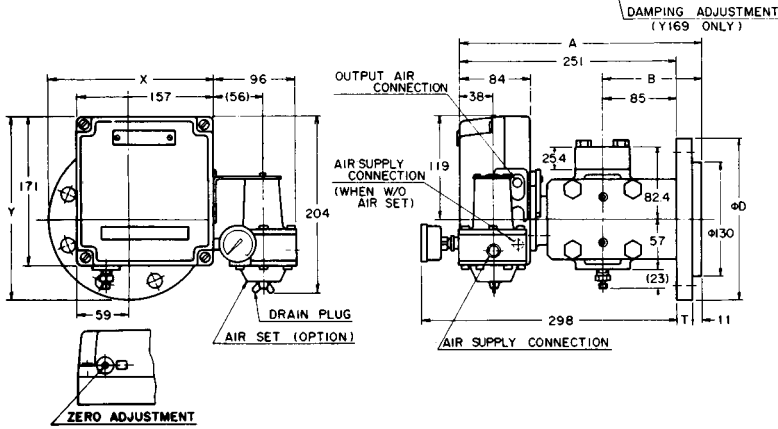

Flange Dimensions

ITEM	FLANGE RATING	D	T	C	n	h	i	BOLT
1	80 mm JIS 10K RF	185	18	150	8	19		M16
2	80 mm JIS 30K RF	210	28	170	8	23		M20
3	3" ANSI 150 RF	191	24	152.4	4	19		5/8
4	3" ANSI 300 RF	210	29	168.3	8	22		3/4
A	3" JPI 150 RF	191	24	152.4	4	19		5/8
B	3" JPI 300 RF	210	29	168.3	8	22		3/4

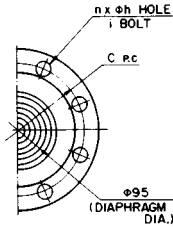

Extended Diaphragm Type

Main Dimensions

ITEM	FLANGE RATING	A	B	X	Y
5	100 mm JIS 10K RF	280	114	203	224
6	100 mm JIS 30K RF	294	128	218	239
7, C	4" ANSI/JPI 150 RF	286	120	212.5	233.5
8, D	4" ANSI/JPI 300 RF	294	128	225	246

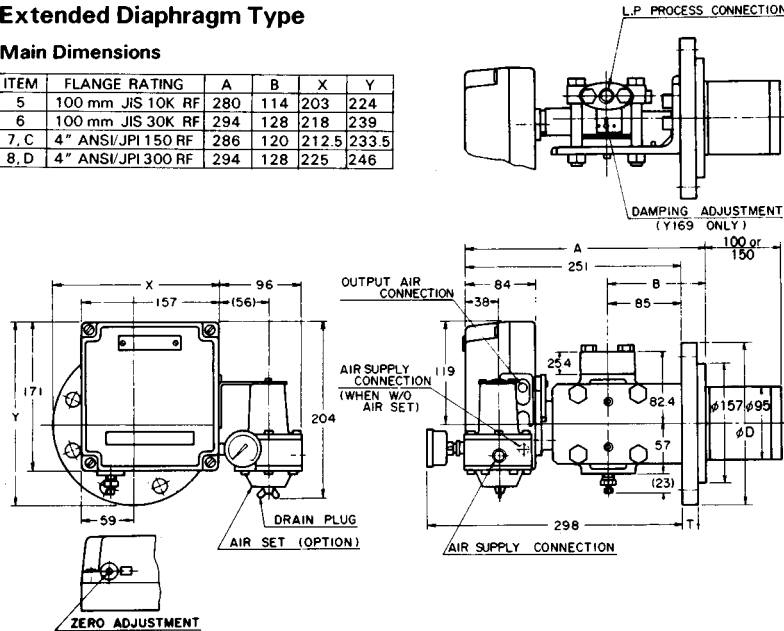

Flange Dimensions

ITEM	FLANGE RATING	D	T	C	n	h	i	BOLT
5	100 mm JIS 10K RF	210	18	175	8	19		M16
6	100 mm JIS 30K RF	240	32	195	8	25		M22
7	4" ANSI 150 RF	229	24	190.5	8	19		5/8
8	4" ANSI 300 RF	254	32	200	8	22		3/4
C	4" JPI 150 RF	229	24	190.5	8	19		5/8
D	4" JPI 300 RF	254	32	200	8	22		3/4

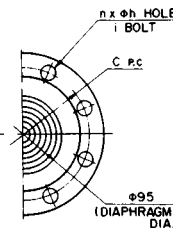

Ordering Information

When ordering, please specify:

- 1) Model No.
- 2) Measuring range
 Note) PREX3000 Transmitter covers a wide measuring range. At a span close to the minimum range point, however, the instrument exhibits particular characteristics. When operating the instrument at this span, refer to Instrumentation Data Sheet ID2-522-002.
- 3) Optional specification
- 4) Optional semi-standard specification
 Note) For any combination of two or more Y-specification items, please consult us.

Reference instruction manual . . .

OM2-5220-0000/
OM2-5220-1100

Specifications are subject to change without notice.

YAMATAKE

Yamatake Corporation

Totate International Building
2-12-19 Shibuya
Shibuya-ku Tokyo 150-8316
Tel : 81-3-3486-2216
Fax: 81-3-3486-2503

Yamatake-SIC Control Systems Co., Ltd.	: China	86-10-6326-9844/55
Shanghai Yamatake Jinshan Control Instruments Co., Ltd.	: China	86-21-5793-5334
Yamatake Korea Co., Ltd.	: Korea	82-2-785-0280-2
Yamatake (Thailand) Co., Ltd.	: Thailand	66-2-210-0900~7
Yamatake Philippines, Inc.	: Philippines	63-2-817-6452
PT. Yamatake Berca Indonesia	: Indonesia	62-21-230-5537/5539
Yamatake Controls Singapore Pte. Ltd.	: Singapore	65-778-5966
YCV Corporation	: U.S.A.	1-602-548-1800

Savemation

Saving through Automation

Yamatake Industrial Systems Co.,Ltd.

<http://www.yamatake.co.jp/>

9904-Y/Y

This has been printed on recycled paper.