

# Liquid Level Detectors (Meter Bodies) for KFL-B Series User's Manual

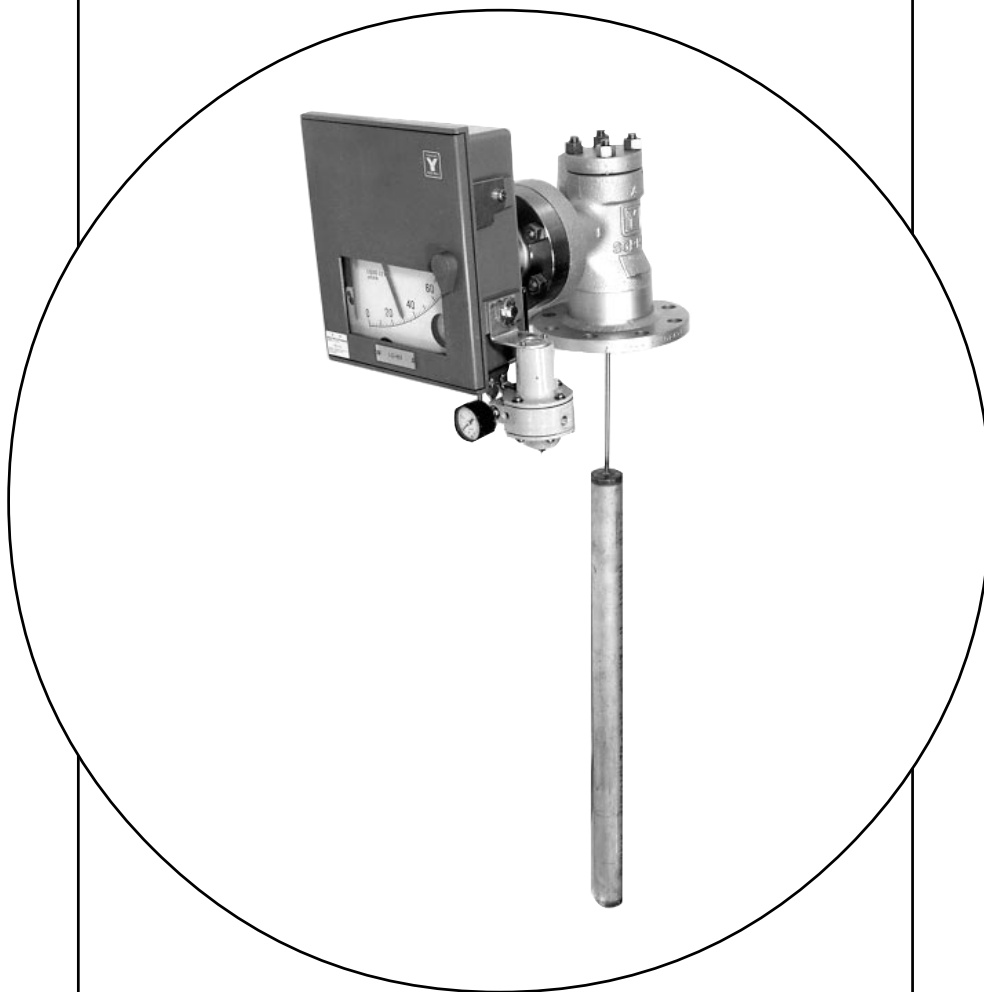

Yamatake Corporation

# Copyright, Notices and Trademarks

---

**Printed in Japan - © Copyright 2000 by Yamatake Corporation.**

While this information is presented in good faith and believed to be accurate, Yamatake Corporation disclaims the implied warranties of merchantability and fitness for a particular purpose and makes no express warranties except as may be stated in its written agreement with and for its customer.

In no event is Yamatake Corporation liable to anyone for any indirect, special or consequential damages, The information and specifications in this document are subject to change without notice.

## GENERAL

### 1. Description

The liquid level (density) meter body is installed with flanges on the side or top of an open or closed tank. The meter body detects the top level, boundary level, or specific-gravity of liquid contained in the tank into buoyancy of a float. The buoyancy is converted into torque by a torque tube and the torque force is applied to a pneumatic signal transmitter (Model KFLB) or to a controller (Model KFL). The meter body is directly coupled to the instrument. The detecting section is comprised of a meter body, a chamber, and a bonnet.

### 2. Types of Meters

Type/Specific-gravity Range	Instrument Used in Conjunction	Operator's Manual Used in Conjunction
Torque tube type, medium specific-gravity range	KFLB□□-51	OM2-6220-0000
Torque tube type, low specific-gravity range	KFLB□□-52	
High damping type, medium specific-gravity range	KFLB□□-31	
High damping type, low specific-gravity range	KFLB□□-32	

3. Instructions for Instrument (Transmitter or Controller) to be Used in Conjunction

Refer to the operator's manuals mentioned in Section 2. These manuals cover the operating principles, replacement procedures of service units, and calibration and adjustment procedures of the instruments.

4. Combination of Float, Bonnet, and Chamber

The float diameter and length differ by the specific-gravity range and measuring range, and the sizes of the bonnet and chamber to be used in conjunction differ accordingly.

## STRUCTURE OF METER BODY

### 1. Torque Tube Type

#### 1.1 General

The structure of the torque tube assembly is as shown in Figure 1.

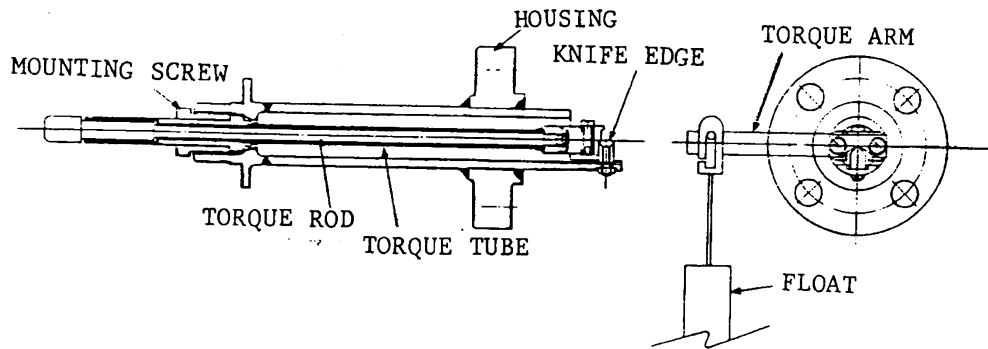

Figure 1. Structure of the Torque Tube Assembly

#### 1.2 Operating Principles

One end of the torque tube is fixed to the housing and the other end is coupled to a torque arm which is supported with a knife edge fulcrum. A float is hung at the end of the torque arm, keeping the torque tube constantly in a twisted state.

As the liquid level rises, a buoyancy force in the upward direction is exercised on the float. This force is fed via the torque arm and knife edge to the torque tube in the direction that its torque is reduced. The torque in the form of the rotating angle of the torque rod is fed to the transmitter.

## 2. High Damping Type

### 2.1 General

The structure of the meter body is as shown in Figure 2.

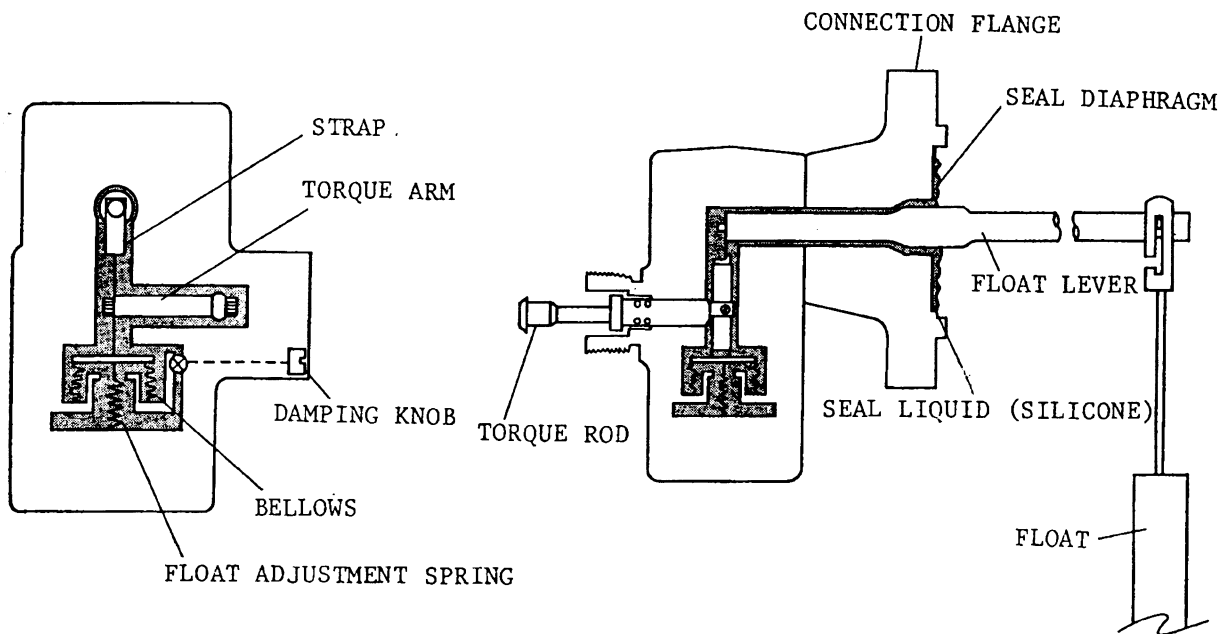

Figure 2. Structure of the Meter Body

### 2.2 Operating Principles

As the liquid level rises, the upward buoyancy force exercised on the float increases. This force is fed via the float lever and diaphragm to the strap in the downward direction. Then the force is fed via the torque arm, in the form of the rotary angle of the torque rod, to the transmitter.

A bellows and a spring is connected to the strap. The bellows has two chambers, which are filled with seal liquid and are connected with a restriction for damping adjustment. The spring balances out the weight of the float so that no excessively large force is applied to the torque tube.

## INSTALLATION METHOD

### 1. External Chamber Type

The float chamber must be installed in such manner that, as the liquid level in the tank changes for the full measuring range, that in the float chamber also changes for the full measuring range. The connection method between the tank and the float chamber is as shown in Figure 4A. It is most recommendable to provide stop valves in the connection pipes between the tank and the float chamber in order that the float chamber can be completely isolated from the tank for calibration and maintenance service.

When the liquid level changes very rapidly, it is recommendable to provide an oscillation prevention restriction in the pipe which connects the tank to the float chamber.

It also is recommendable to provide a drain valve at the bottom of the float chamber so that the liquid level in the float chamber is readily adjustable for instrument calibration.

The float chamber and the connecting pipes should be protected with heat insulator when there is a possibility of increase in viscosity of the measured liquid in the float chamber due to cooling or when heat loss is required to be prevented.

### 2. Internal Chamber Type\*

The internal type of float should be installed as shown in Figure 4B. When there is a possibility of agitation of the measured liquid, side plates or guide plates should be provided as shown in Figure 4B in order to prevent sway of the float.

\*Note: For the side mount type, the flange section is delivered with a protector fixed with two sets of bolts and nuts. Remove the protector before installing the flange section.

### 3. Tightening Torques of Chamber Flange Bolts

The sizes of bolts and the tightening torques of the bolts after replacing the gaskets with new ones should be as shown in the below table. When the flange and/or bonnet of a used instrument are removed by removing their bolts, their gaskets should be replaced with new ones. Note that leak may result if the old ones are re-used.

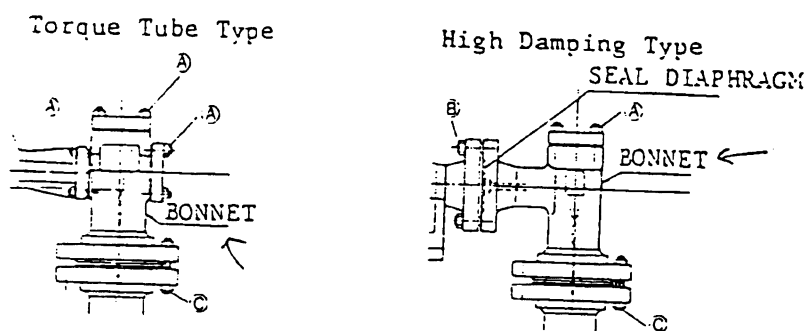

Figure 3. Flange Section

	Bolt Size	Tightening Torque (N·m)
A	M14	130±20 {1326±204 kgf·cm}
B	300 or less M14	130±20 {1326±204 kgf·cm}
	600 M20	250±20 {2549±204 kgf·cm}
C	3B, 4B 150 M16	150±20 {1530±204 kgf·cm}
	Other than the above M20	250±20 {2549±204 kgf·cm}

### 4. Installing the Float

Normally\*, the float is delivered separately from the instrument (including the meter body).

\* Note: Except the floats which have been approved for high pressure chambers and whose lengths are not greater than 2 meters.

Of the torque tube type of instrument, the float hanger may be hung in either direction on the arm pin. Of the high damping type of instrument, however, it must be hung from the outer side.

#### 5. Dashpot Pin

A pin is provided at the cap section of the dashpot of the transmitter beam in order to prevent leak of dashpot oil. When operating the instrument, remove the dashpot pin.

#### 6. General Precautions

Install the instrument to the process in the direction that the instrument is positioned vertically.

The allowable ambient temperature range of the instrument is -30 to +80 degrees C. Protect the instrument within this temperature range.

The stop valves and mating flanges shown in Figure 4 must be provided by the process side (by the customer). The instrument supplied is up to the flange of the meter body (chamber).

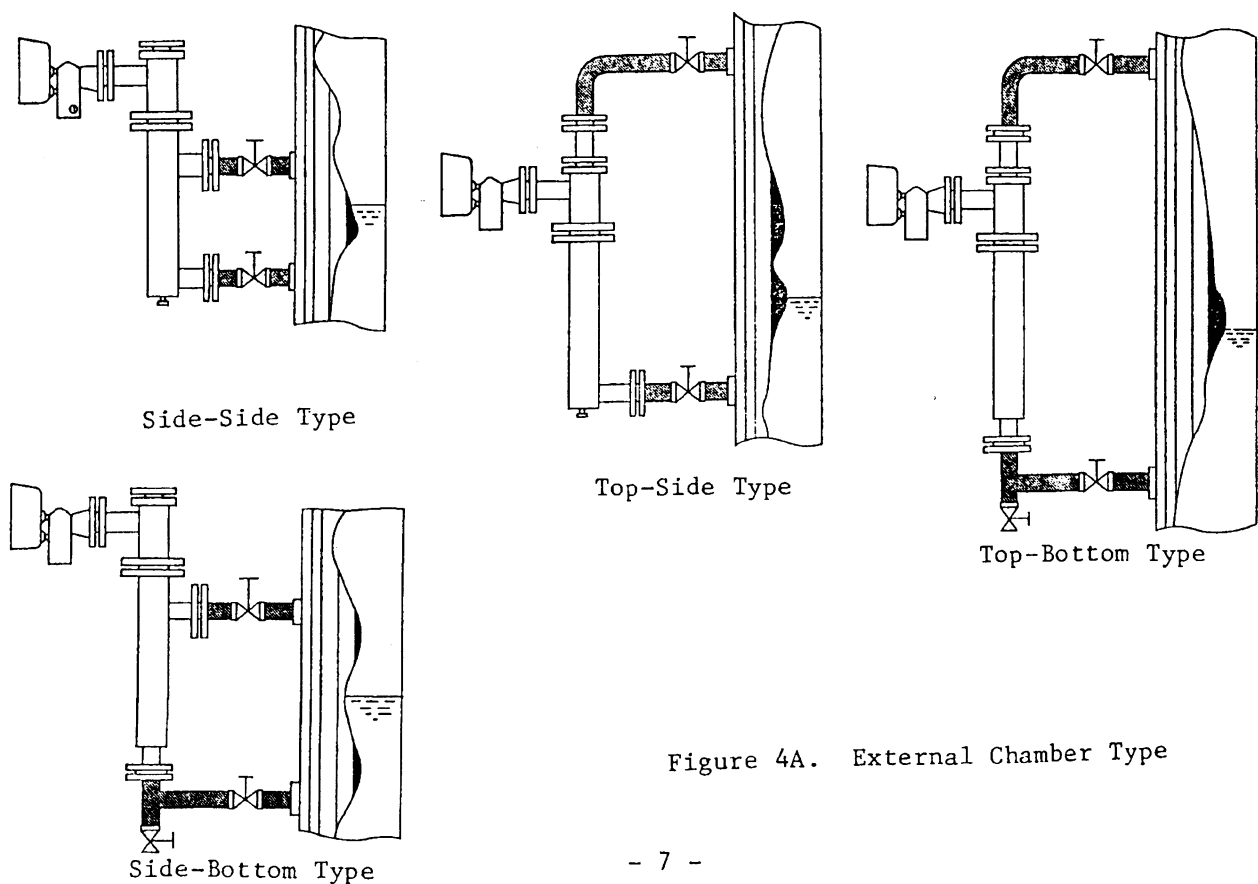
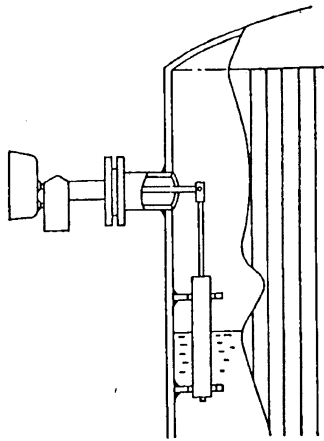
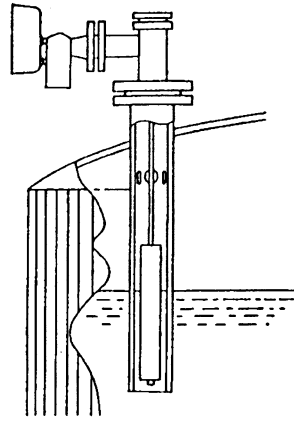

Figure 4A. External Chamber Type



Side Mount Type



Top Mount Type

Figure 4B. Internal Float (Chamber) Type

## OPERATION AND MAINTENANCE

### 1. Operation

For the preparative adjustments to be rendered before starting operating the liquid level transmitter, refer to the operator's manual of the instrument.

When feeding liquid into the chamber, gradually open the valve so that no abrupt change of pressure or liquid level (including flushing) is caused.

Note: When measuring the boundary level between two liquids, the float must be completely submerged in the upper liquid.

### 2. Maintenance

The instrument should be carefully serviced when the process is in pause as the instrument cannot be readily serviced when the process is in operation.

So far as the instrument (meter body) is operated in the specified conditions, it will not be corroded or damaged and it will require no particular service.

Note: When the float is damaged by abnormal pressures or by corrosion, it should be immediately replaced.

Sediment collected at the bottom of the float chamber can be eliminated by draining out. If sediment cannot be completely removed by draining alone, clean the inside of the chamber employing steam or other means as follows:

- (a) Close the stop valves of the top and bottom connecting pipes between the tank and the float chamber.
- (b) Carefully disconnect the meter body from the float by removing the bolts and nuts which connect the meter body to the bonnet, exercising care so that no abnormally large force is applied to the torque arm.

- (c) Disconnect the bonnet by removing the bolts and nuts which connect the bonnet to the chamber.
- (d) Disconnect the chamber from the connecting pipes and clean the insides of the bonnet and chamber.
- (e) To assemble the instrument, follow the above procedure in the reverse order, referring to the instructions given in Section "INSTALLATION METHOD."

# Note



---

**Document Number :** OM2-5260-2100

**Document Name :** Liquid Level Detectors (Meter Bodies)  
for KFL-B Series

---

**Date :** Feb., 2000 Rev.4 (H)

**Issued / Edited by :** Yamatake Corporation

---

***azbil***

---

**Yamatake Corporation**  
**Advanced Automation Company**

1-1-12 Kawana, Fujisawa  
Kanagawa 251-8522 Japan

**URL:**<http://www.azbil.com>