

# KG Series Model KGT

## Temperature Indicating Controller

### OVERVIEW

Model KGT Field Mounted Temperature Indicating Controller measures, indicates and controls process temperature. It measures temperature by detecting it into mechanical displacement with a liquid-fill type temperature sensor.

The KGT is a simplified dedicated-purpose instrument which is greatly economical and reliable.



### FEATURES

- **Vibration-resistant**

Bellows are employed to detect temperature change. The bellows provide a very large torque which is less affected by vibration.

- **Twin bellows**

P-action unit bellows are made up of a single bellow separated into two chambers. It provides excellent matching of effective and operates very reliably.

- **Case**

The case is sturdy and highly resistant against heat, weather, and vibration.

**SPECIFICATIONS****Standard Specifications**

Item	Specification												
<b>Detector section</b>													
Measuring range, Maximum allowable temperature	<table border="1"> <thead> <tr> <th>Measuring range (°C)</th><th>Max. allowable temp. (°C)</th></tr> </thead> <tbody> <tr><td>0 to 50</td><td>75</td></tr> <tr><td>0 to 100</td><td>120</td></tr> <tr><td>0 to 150</td><td>180</td></tr> <tr><td>0 to 200</td><td>240</td></tr> <tr><td>0 to 300</td><td>360</td></tr> </tbody> </table>	Measuring range (°C)	Max. allowable temp. (°C)	0 to 50	75	0 to 100	120	0 to 150	180	0 to 200	240	0 to 300	360
	Measuring range (°C)	Max. allowable temp. (°C)											
0 to 50	75												
0 to 100	120												
0 to 150	180												
0 to 200	240												
0 to 300	360												
Element material	Bellows : Phosphor bronze Spiral : SUS316												
<b>Performance</b>													
Indicating accuracy	± 1.0% FS												
Repeatability	Within 0.5% FS												
Dead band	Within 0.3% FS												
<b>Indicator section</b>													
Indicating angle	44 degrees												
Scale length	111.3 mm												
Pointers	PV: Red      SP: Green												
<b>Setting section</b>													
Setting method	Local setting ( internal setting with a setting knob of case inside.)												
Setting range	0 to 100 % FS												
<b>Controller section</b>													
Control mode	PI action , PID action												
Controller performance	Proportional band (P) : 5 to 500% ( direct or reverse action)												
	Integral time (I) : 0.05 to 30 min.												
	Derivative time (D) : 0.05 to 30 min.												
<b>General specification</b>													
Output	20 to 100 kPa { 0.2 to 1.0 kgf/cm <sup>2</sup> }												
Minimum load	ID 4 mm × 3 m + 20 cm <sup>3</sup>												
Supply air pressure	140 ± 14 kPa { 1.4 ± 1.4 kgf/cm <sup>2</sup> }												
Air consumption	5 L/min [N]												
Pneumatic delivery capacity	40 L/min [N]												
Pneumatic exhaust capacity	40 L/min [N]												
Supply and output connection	Rc 1/4 or 1/4 NPT internal thread												
Ambient temperature	-30 to 75 °C												
Ambient humidity	10 to 90% RH												
Material	Case and door: FRP (polyester with fiber glass) Interior air pipe: Urethane Mounting bracket: Carbon steel (zinc plated) Mounting bolt and nut: SUS304												
Applicable standards	<ul style="list-style-type: none"> <li>• JIS F8001 class 3 splash proof, NEMA type 3 and IEC IP54 equivalent.</li> <li>• Lloyd's Register of Shipping and Nippon Kaiji Kyokai rule authorized</li> <li>• JIS F0807 equivalent</li> </ul>												
Color of finish	Dark beige (Munsell 10YR 4.7/0.5 equivalent)												
Mounting method	Direct mounting without bracket, 2 in. pipe mounting or Surface mounting.												
Weight	Approx. 5.5 kg ( KGTA12-08100A1T-U1)												

**Optional Specification**

Item	Specifications
(1) With Pressure regulator with filter	Pressure regulator with filter plus 40mm Pressure gauge ( primary pressure;                    200 to 990 kPa { 2 to 9.9 kgf/cm <sup>2</sup> } secondary pressure;                140 Kpa { 1.4 kgf/cm <sup>2</sup> } pressure gauge range;                0 to 200 kPa { 0 to 2 kgf/cm <sup>2</sup> } )  Air consumption :            0.95 L/min [N] Air connection:                RC1/4 or ¼ NPT internal thread
(2) With output gauge	Range:                    0 to 200 kPa { 0 to 2 kgf/cm <sup>2</sup> }
(3) With union	Material :                SUS304 Connection : R ¾ or ¾ NPT external thread

**MODEL SELECTION**

Ex: KGPA 12-01003A 1S-G

Basic model no.			Selections					Options	Description
Type	Function	Control action	Sensing element	Measuring range	Air connection	Output pressure unit	Mounting method		
KGT									Temperature indicating controller
	A1								Local type controller
		2							PI
		3							PID
			-08						Liquid fill type
				050					0 to 50 °C
				100					0 to 100 °C
				150					0 to 150 °C
				200					0 to 200 °C
				300					0 to 300 °C
					A				Rc 1/4
					B				1/4 NPT internal thread
						1			0.2 to 1.0 kgf/cm <sup>2</sup>
						2			3 to 15 PSI
						3			0.2 to 1.0 bar
						4			20 to 100 kPa
						8			19.6 to 98.1 kPa (equality to 0.2 to 1.0 kgf/cm <sup>2</sup> )
							M		Direct mounting without bracket *1
							S		Wall mounting
							T		2 in. pipe mounting
							X		No option
							7		With Pressure regulator with filter
							G		With output gauge (40 mm)
							U1		With union R3/4 (PT3/4)
							U2		With union 3/4NPT
							D		With damping unit *1

\*1 For direct mounting, Pressure regulator with filter cannot be installed.

Well (Liquid-fill type)

Ex.; KFZ1-1112-15

Basic model no.		Selections			Options	Description		
		Type	Connection	Material				
KFZ	1					Well for temperature element		
		-1				For liquid-fill type (drilled)		
		-2				" (welded)		
			11			Flange connection	20 mm-JIS10K	
			12			"	25 mm-JIS10K	
			13			"	40 mm-JIS10K	
			14			"	50 mm-JIS10K	
			21			"	20 mm-JIS20K	
			22			"	25 mm-JIS20K	
			23			"	40 mm-JIS20K	
			24			"	50 mm-JIS20K	
			31			"	¾ in.-ANSI 150	
			32			"	1 in.-ANSI 150	
			33			"	1½ in.-ANSI 150	
			34			"	2 in.-ANSI 150	
			41			"	¾ in.-ANSI 300	
			42			"	1 in.-ANSI 300	
			43			"	1½ in.-ANSI 300	
			44			"	2 in.-ANSI 300	
			71			"	¾ in.-JPI 150	
			72			"	1 in.-JPI 150	
			73			"	1½ in.-JPI 150	
			74			"	2 in.-JPI 150	
			81			"	¾ in.-JPI 300	
			82			"	1 in.-JPI 300	
			83			"	1½ in.-JPI 300	
			84			"	2 in.-JPI 300	
			91			"	¾ in.-ANSI 600	
			92			"	1 in.-ANSI 600	
			93			"	1½ in.-ANSI 600	
			94			"	2 in.-ANSI 600	
			51			Screw connection	R¾	
			52			"	R1	
			61			"	¾NPT	
			62			"	1 NPT	
			2			SUS316		
			7			SUS304		
			8			SUS316L		
						Insertion length	Drilled	Welded
			15			150 mm	Available	
			20			200 mm	Available	
			25			250 mm	Available	Available
			30			300 mm	Available	Available

Note) \*marked means Protecting tubes with insertion lengths (extension lengths) longer than 600 mm are available as special order items (standard length 700 mm).

**DIMENSIONS**

(unit : mm)

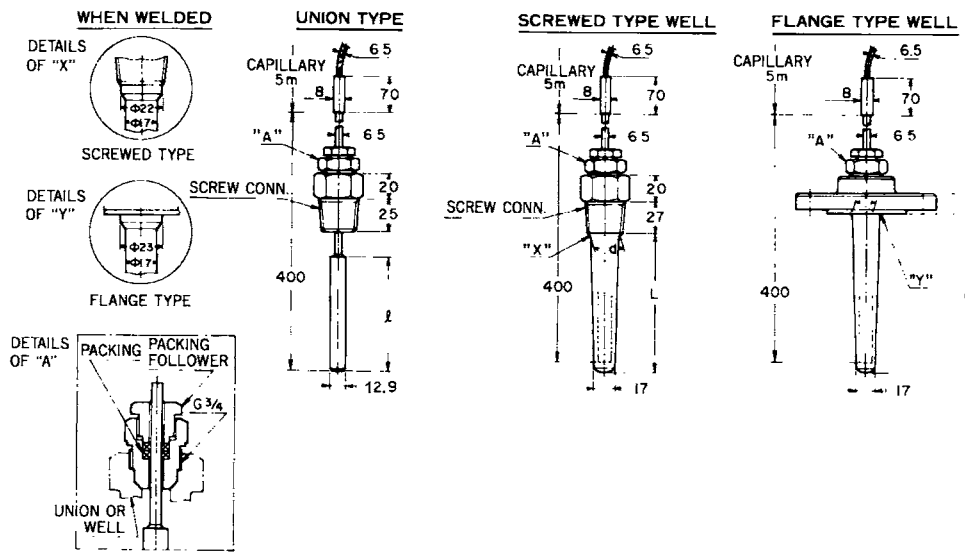

**Table 1. Bulb dimensions**

Measuring range	<i>l</i>
0 to 50 °C	145
0 to 100 °C	83
0 to 150 °C	63
0 to 200 °C	45
0 to 300 °C	35

**Table 2. Screw connection**

ITEM	Screw size
51	R ¼ External
52	R1 External
61	3/4NPT External
62	1NPT External

**Table 3. Well dimensions**

ITEM	Immersion length L(mm)	d	
		Welded	Drilled
-15	150	—	18
-20	200	—	19
-25	250	17	20
-30	300		21

(unit : mm)

DIRECT MOUNTING  
WITHOUT BRACKET

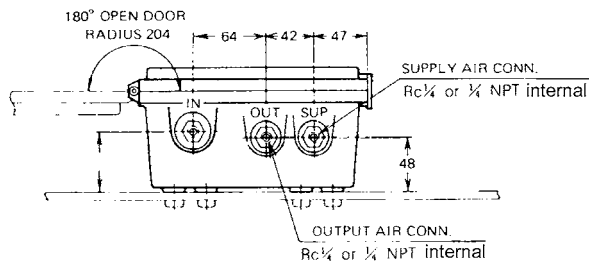
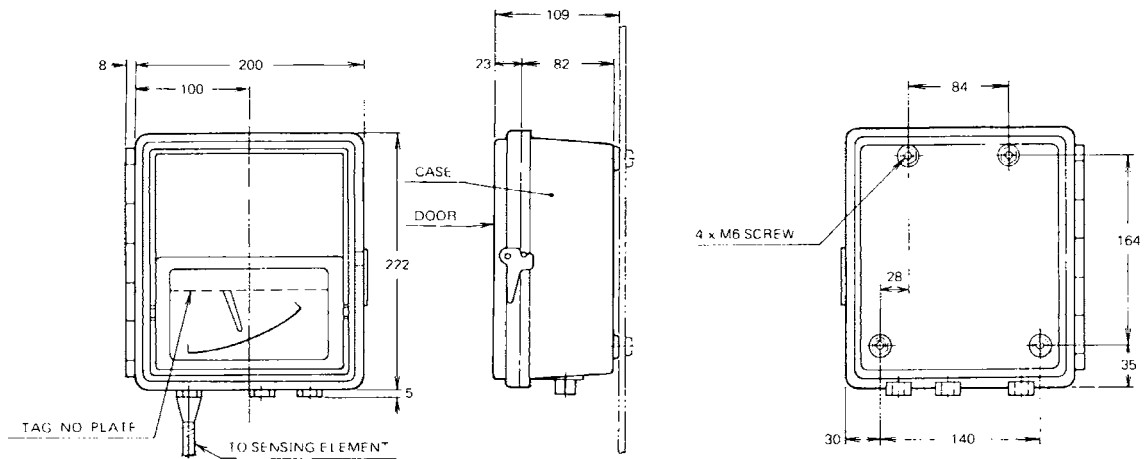

SURFACE MOUNTING

DETAIL OF MOUNTING BRACKET

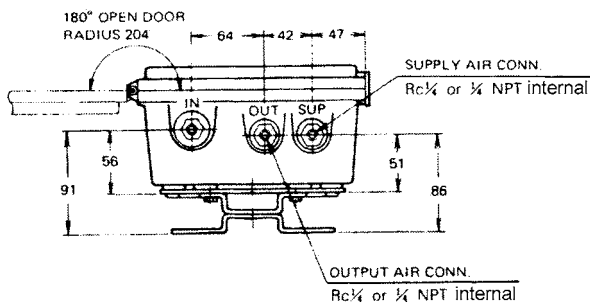
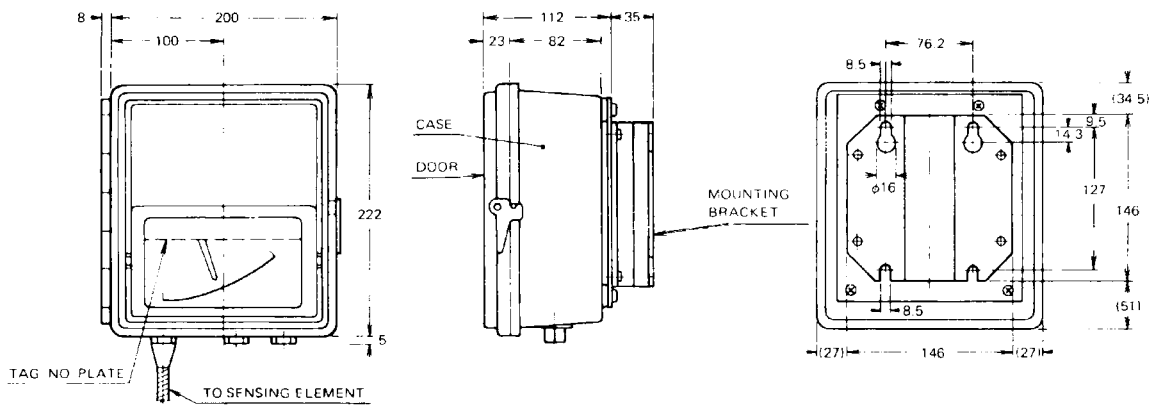

WITH OUTPUT GAGE

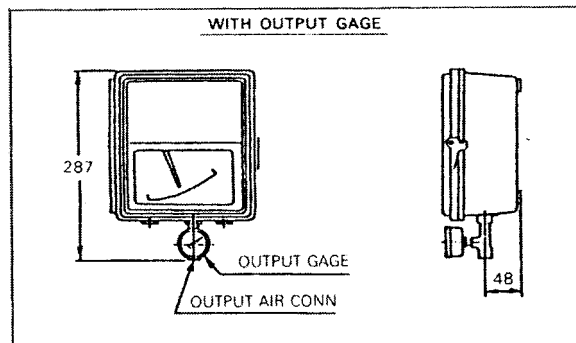



## Yamatake Corporation

Totate International Building  
2-12-19 Shibuya  
Shibuya-ku, Tokyo 150-8316  
Japan

Tel : 81-3-3486-2216  
Fax : 81-3-3486-2503



Certificate No. Q17862

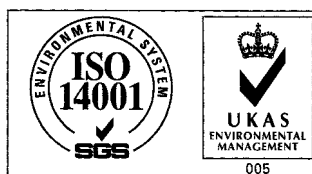

Certificate No. E8318  
For Shonan Factory

# YAMATAKE

**Savemation**

*Saving through Automation*

<http://www.yamatake.co.jp/>