

KF-B Series Field Mounted Indicating Controller

User's Manual

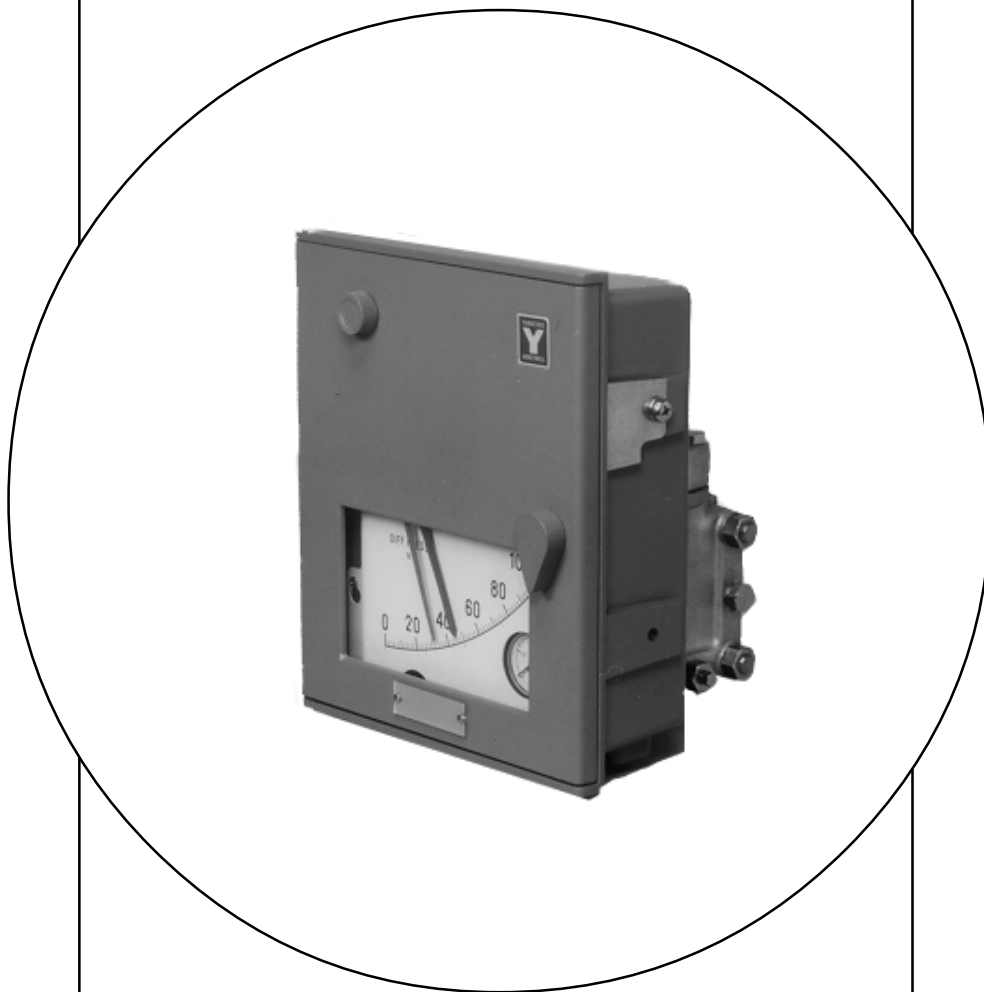

Yamatake Corporation

Copyright, Notices and Trademarks

Printed in Japan - © Copyright 2000 by Yamatake Corporation

While this information is presented in good faith and believed to be accurate, Yamatake Corporation disclaims the implied warranties of merchantability and fitness for a particular purpose and makes no express warranties except as may be stated in its written agreement with and for its customer.

In no event is Yamatake Corporation liable to anyone for any indirect, special or consequential damages, The information and specifications in this document are subject to change without notice.

1. GENERAL

1.1 Description

The KF Series Field Mounted Indicating Controller detects and indicates a process variable (flow, pressure, liquid level, etc.), and transmits and indicates a pneumatic control signal (20 to 100 kPa {0.2 to 1.0 kgf/cm²}) by comparing the detected value with the setpoint value.

The setpoint is adjustable locally (manually) with the setting control on the front panel or inside of the instrument or remotely (in a cascade system) with an external pneumatic signal.

It also is possible to transmit a pneumatic process variable signal (20 to 100 kPa {0.2 to 1.0 kgf/cm²}).

The instrument can be converted to measure a flow (differential pressure), liquid level, or pressure simply by changing the detector elements.

1.2 Structure

Mechanically, the instrument consists of a detector (meter) unit, transmitter unit, pneumatic signal receiver unit, deviation detecting and indicating unit, controllers, manual loader, pilot relay, case and door. Functionally, the instrument is comprised of a process variable transmitter section including the detector unit, and a (receiving) indicating controller section.

Note: This manual covers the transmitter section and indicating controller section. For the detectors, refer to respective operator's manuals which cover procedures for connection of the instrument to the process, instrument calibration setup, and preparation for instrument operation.

1.3 Detectors (Meter Bodies)

Process Variable	Range or Type	Model No.	Operator's Manual
Differential pressure	High or medium differential pressure	KFDB11/22	OM2-5220-1100
	Low differential pressure	KFDB33	
	Very low differential pressure	KFDB44	
	Flange type	KFDB61/62	
	Remote sealed type	KFDB71/72	
	High working pressure type	KFDB81/82	
Pressure	High pressure	KFKB11/12/13/14	OM2-5240-1100
	Low pressure	KFKB15/16/17/18	
	Absolute pressure	KFKB25/26/27/28	
	Remote sealed type	KFKB71/72/73/74/75/76	
Liquid level and density	Torque tube type	KFLB□□-51/52	OM2-5260-2100
	High damping type	KFLB□□-31/32	

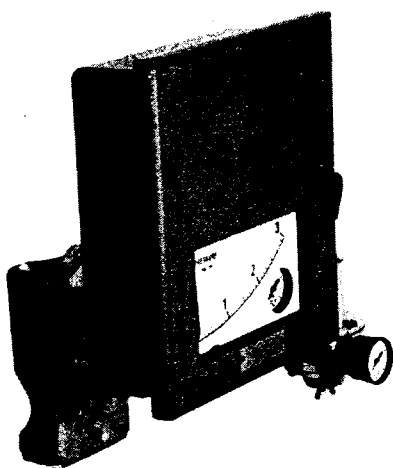

KFP

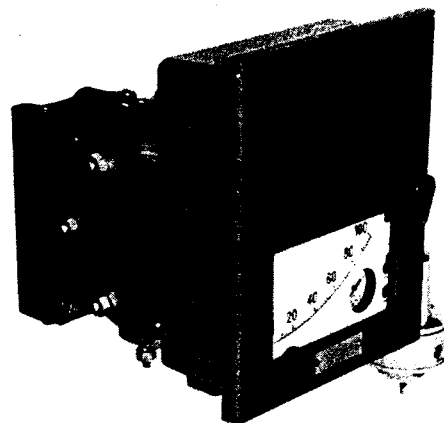

KFD

Figure 1-1. External Views of KF Instrument

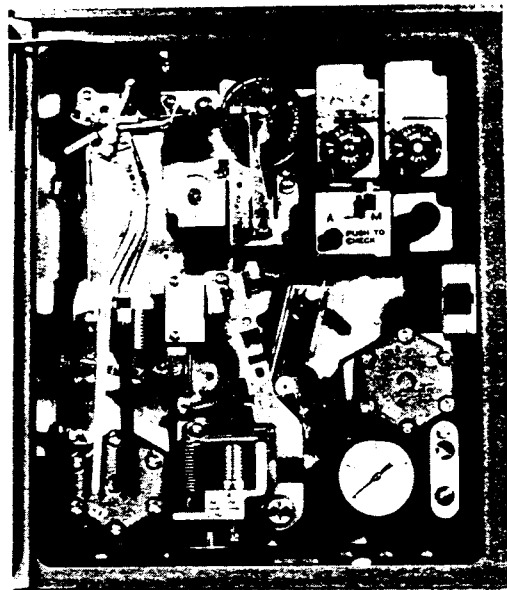
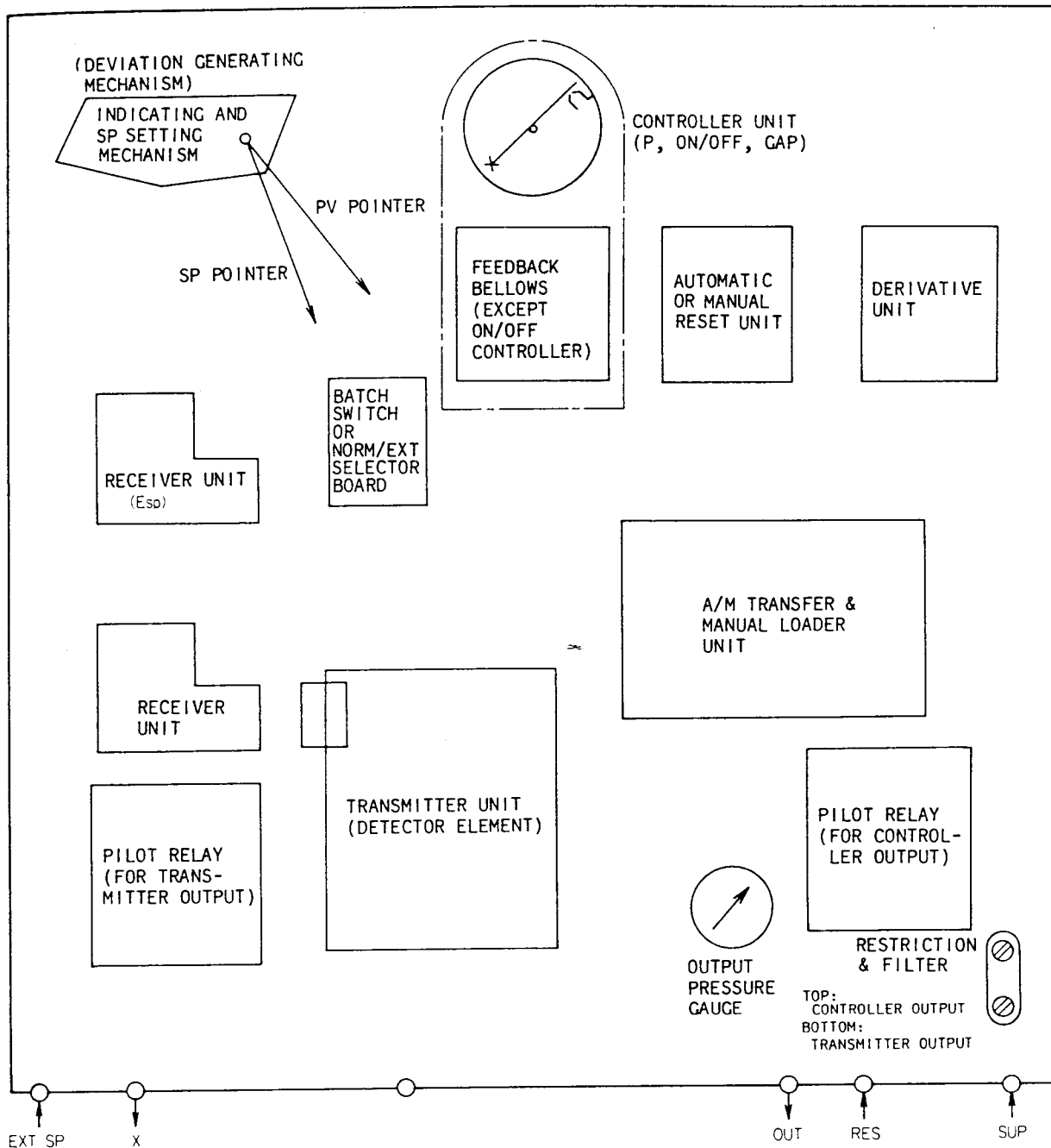

Figure 1-2

Layout of Internal Components

1.4 Specifications

Specifications of Controller (Main Unit)

(1) Performance

Accuracy: $\pm 1\%$ FS
Repeatability: 0.3% FS or better
Dead Band: 0.2% FS or less

(2) Indicator Section

Indicating Angle: 44 deg
Scale Length: 150 mm
Pointers: PV (red), SP (green)
Output Pressure Gauge: Scale 0 to 200 kPa {0 to 2 kgf/cm²}.

(3) Setting Section

Local Setting: With setting control on front panel or inside of case.
Remote Setting: With pneumatic signal of 20 to 100 kPa {0.2 to 1.0 kgf/cm²}
Setting Range: 0 to 100% FS

(4) Controller Section

Control Actions: P + manual reset, PI, PID, PD + manual reset, PI + batch, ON/OFF, differential gap, P + external reset, or PD + external reset
Proportional Band (P): 5 to 500% (direct or reverse action)
Integral Time (I): 0.05 to 30 minutes
Derivative Time (D): 0.05 to 30 minutes
Differential Gap: Adjustable for 1 to 100%
Batch Setting Pressure: Adjustable for 60 to 110 kPa {0.6 to 1.1 kgf/cm²}
External Reset Pressure: 20 to 100 kPa {0.2 to 1.0 kgf/cm²}
Manual Reset: Adjustable for 0 to 100% FS (with pneumatic pressure setting)

(5) General Specifications

Output: 20 to 100 kPa {0.2 to 1 kgf/cm²}, 0 or Supply air pressure (on-off, differential gap)

Minimum Load: Inside diameter 4 mm x 3 m + 20 cm³

Air Supply: 140 ± 14 kPa {1.4 ± 0.14 kgf/cm²}

Air Consumption (Nl/minute):

Indicating Transmitter ... 5,
Indicating Controller 9,
Indicating Controller + Pneumatic Transmitter... 9,
Indicator only 5,
Manual Loader +3 (Additional)

Saturated Air Supply Capacity (Nl/minute):

Pneumatic Transmitter ... 40,
Controller Output 40,
Manual Loader 30

Air Piping Connections: Rc, 1/4 (PT1/4) or
1/4 NPT

Operating Ambient Temperature: -30 to +80°C

Operating Ambient Humidity: 10 to 90% RH

Case and Door:

Case Structure: Water tight, dust tight
JIS F 8001 Class 3 splash proof,
NEMA 3, IEC IP 54

Materials:

Case: Aluminium diecast
Cover: Glass fiber reinforced polyester resin
Finish: Baked acryl paint (corrosion resistant paint
and silver paint are semi-standard.)
Color: Dark beige (Munsell 10YR4.7/0.5)

Installation:

Pressure Model (KFKB):

2-inch pipe stanchion or panel flush
mount

Differential Pressure Model (KFDB):

2-inch pipe stanchion, panel flush mount,
or direct mount on process

Liquid Level Model (KFLB):

Direct mount on process

1.5 Transmitter Section

The mechanical displacement detected by the detector section is converted into torque which is conveyed via the seal tube (torque rod) to the input beam to drive the flapper which dictates the nozzle back pressure which is amplified by the pilot relay in order to be delivered as pneumatic output signal.

The pneumatic output signal is converted into force by the feedback bellows and vector component F_1 is fed back to the beam via the strap as shown in Figure 1-3, thereby making up a feedback loop which brings the beam into equilibrium when the pneumatic output signal has reached a value corresponding to the torque input signal.

Elevation or suppression is accomplished by applying force to the beam with a spring. Span change is accomplished by changing the direction of vector F_3 to change the component of vector F_1 and thereby changing the feedback gain.

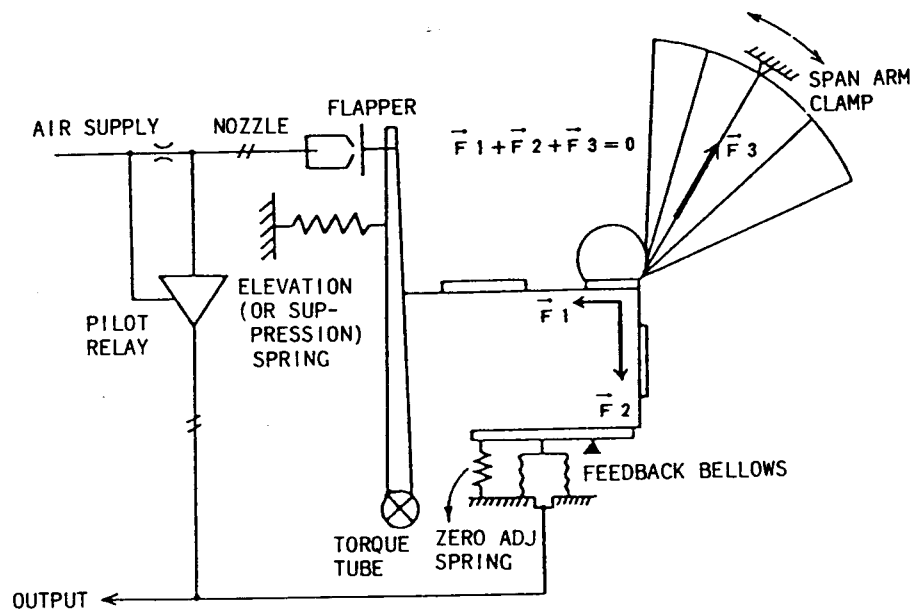

Figure 1-3. Operating Principle

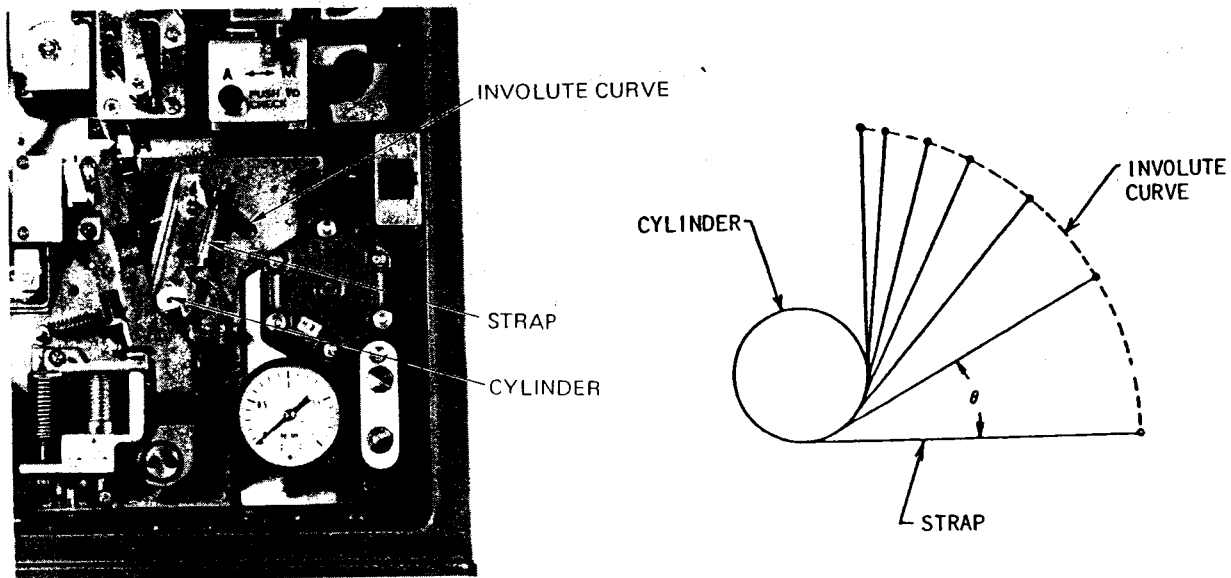

Figure 1-4(a). Involute Curve Section

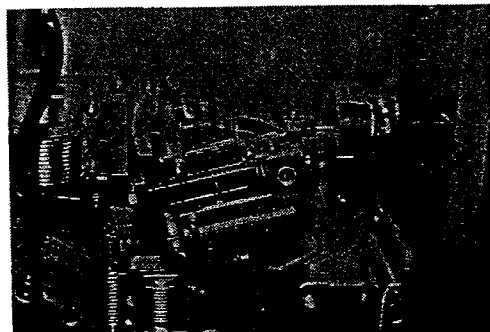

Figure 1-4(b). Dash pot Assembly Condition(Torque Tube Type KFLB)

1-6 Indicating Controller Section

1.6.1 General

The pneumatic output pressure of the transmitter section, which represents the process being measured, is applied to the pneumatic pressure signal receiver unit, thereby causing displacement of the end of the element. The displacement is fed via the overtravel link to the deviation generating mechanism which magnifies the displacement to drive the meter pointer. At the same time, the mechanism provides another deviation signal which is fed to the controller mechanism which renders proportional, integral and/or derivative actions on its input signal in order to deliver a pneumatic control output signal.

1.6.2 Deviation Generating Mechanism

The deviation generating mechanism is comprised of a deviation detecting section and an indicating section. It detects the deviation of the process variable (PV pointer) from the setpoint (SP pointer). The detected deviation is fed via the deviation link to the proportional action unit and changes the positional relationship between the nozzle and the flapper.

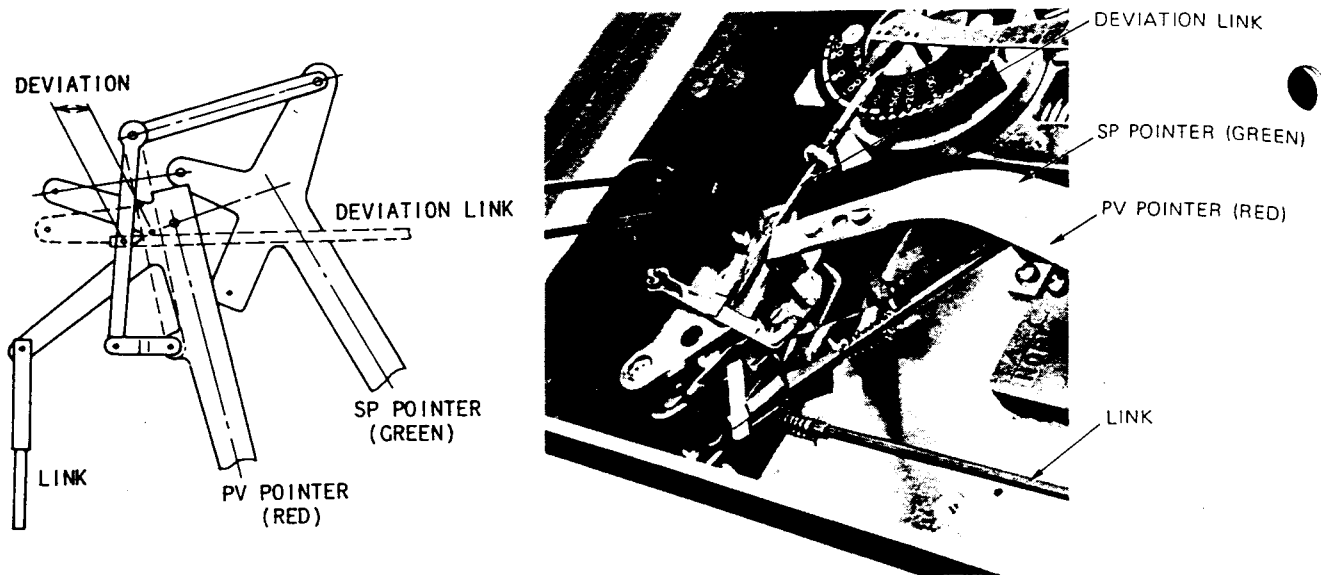

Figure 1-5 Deviation Generating Mechanism

1.6.3 Controller Mechanism

The controller mechanism is comprised of a proportional unit, an integral unit and/or a derivative unit. The various combinations of these controller units are possible and interchangeable to best suit the characteristics of the process to be controlled.

(1) Proportional (P) Unit

This unit is comprised of a nozzle-flapper mechanism and a feedback mechanism (a feedback chamber and a reset chamber). Movement of the deviation link is conveyed to the nozzle flapper mechanism via the flapper pin, which is linked with the feedback link, to change the gap between the nozzle and flapper, thereby changing the nozzle back pressure.

The nozzle back pressure is amplified by the pilot relay to the level of a regular pneumatic control signal. The amplified pneumatic output pressure of the controller is fed back to the nozzle flapper mechanism via the feedback chamber to change negatively the gap between the nozzle and flapper. The controller mechanism reaches an equilibrium state when the pneumatic output pressure proportional to the input deviation is attained.

Proportional band is adjustable by turning the proportional band dial. As this dial is turned, the angles made up by the flapper, deviation link and feedback link are varied.

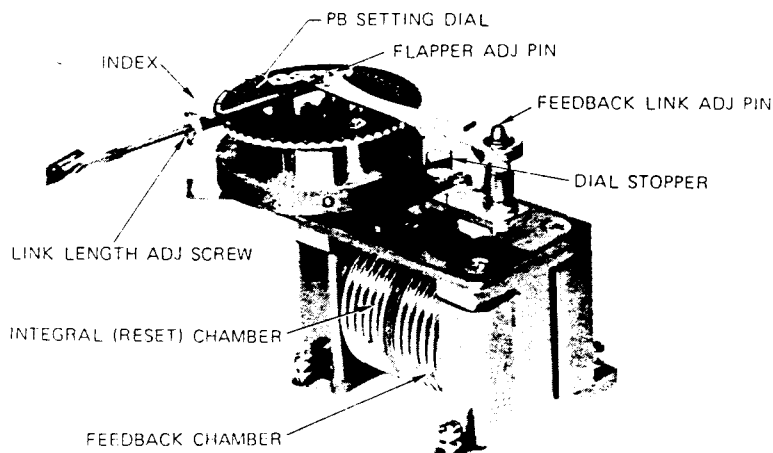

Figure 1-6 Controller Mechanism

(2) Integral Unit and Derivative Unit

The pressure of the feedback chamber of the proportional unit is fed to the integral (reset) chamber of the proportional unit via the restriction and capacity chamber of the integral unit in order to provide an integral (I) action. By adding the derivative unit, a derivative (D) action can be attained.

A derivative bellows is provided in the chamber of the derivative unit and part of the pneumatic output pressure is directly fed to this bellows to adjust the amplitude of derivative action.

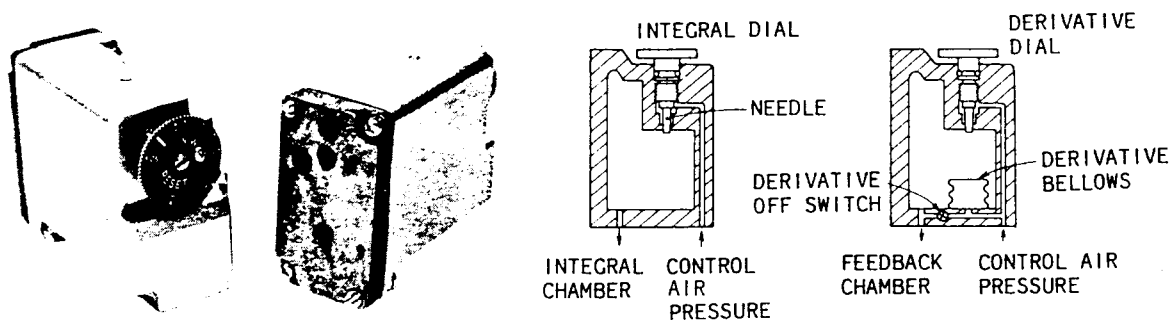

Figure 1-7 Integral Unit and Derivative Unit

(3) Other Controller Units

a) ON/OFF Unit

This unit is used for control of process whose time constant is large but dead time is small. This unit is structured by eliminating the feedback mechanism from the proportional control unit so that the nozzle back pressure is directly applied to the pilot relay. The ON/OFF actions take place depending on whether the nozzle is uncovered or covered by the flapper.

b) Differential Gap Unit

This unit is used in such case that, if the ON/OFF controller is used, ON/OFF action will be repeated too frequently and the actuator or other device will be adversely affected.

This unit is structured by replacing the feedback chamber of the proportional unit with a spring and feeding the output pressure of the pilot relay to the integral chamber. The differential gap width is adjustable for a range of 1 to 100%.

c) Manual Reset Unit

This unit is structured so that the output pressure of the pilot relay is applied to the feedback chamber of the proportional unit and a reset pressure (20 to 100 kPa {0.2 to 1.0 kgf/cm²}) manually generated with a pressure regulator is applied to the integral (reset) chamber.

d) External Reset Unit

This unit differs from the manual reset unit in that an external reset signal (20 to 100 kPa {0.2 to 1.0 kgf/cm²}) is employed instead of generating it manually (locally) with a pressure regulator. The external pressure signal should be connected to the RES port of the controller.

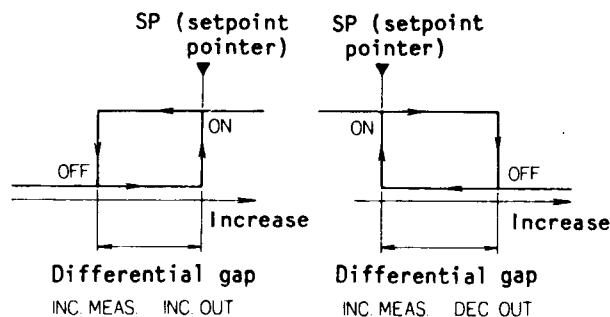

Figure 1-8 Differential Gap

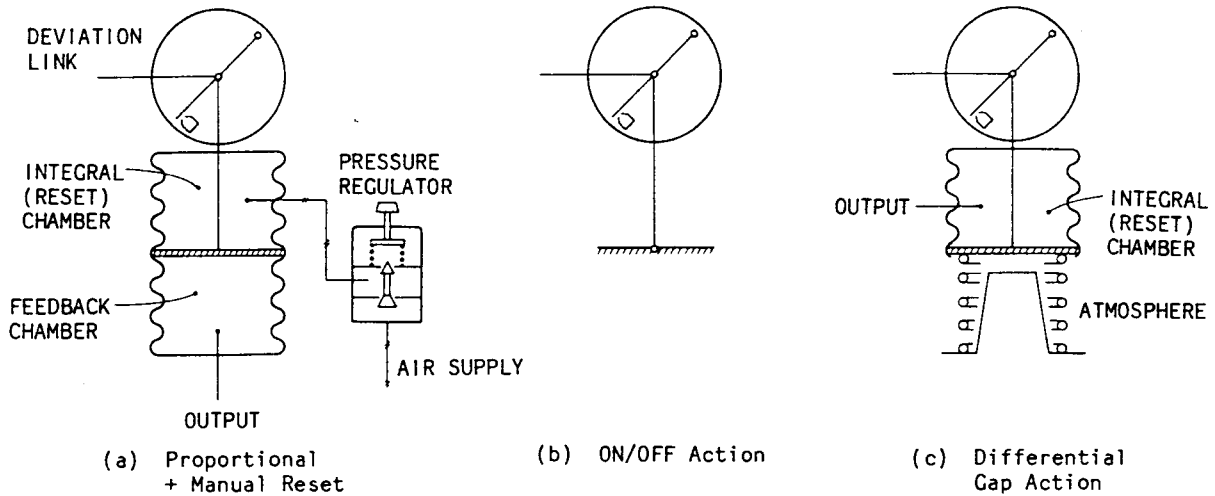

Figure 1-9 Operating Principles

1.6.4 Manual Loader Unit

This unit is comprised of a pressure regulator for manual loading pressure setting, an AUTO/MAN transfer lever, a check switch, etc.

When in the AUTO mode (the transfer lever set in the A position), the controller output gauge indicates the automatic control output pressure of the controller. As you press the check button, the gauge indicates the pressure regulator output (manual loading pressure).

When in the MAN mode (the transfer lever set in the M position), the pressure regulator output is fed to the integral (reset) chamber of the proportional unit and directly indicated by the controller output meter in order to be used as a remote control signal for such device as a valve.

If you press the check button when in this state, the gauge indicates the automatic control output pressure.

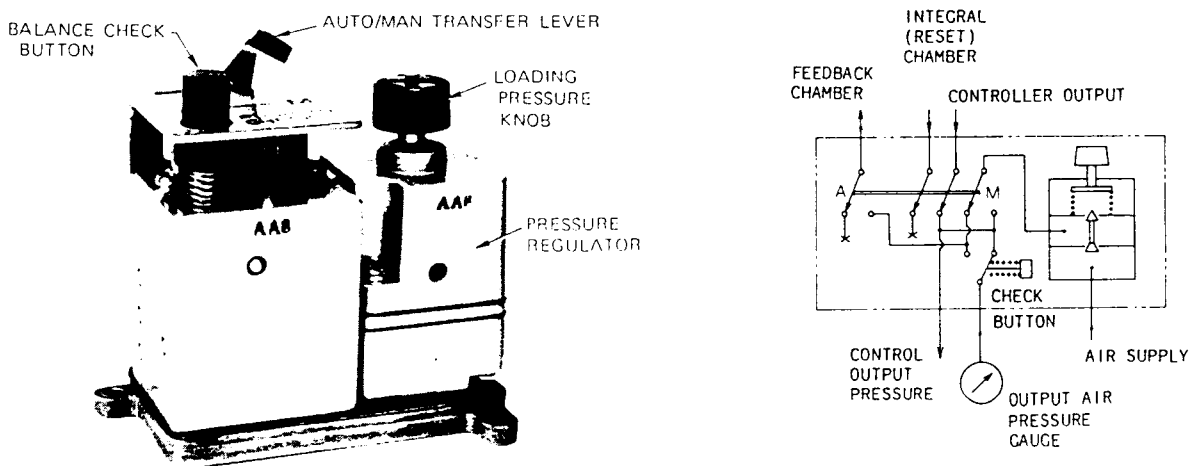

Figure 1-10 Manual Loader Unit

1.6.5 Pneumatic Pressure Signal Receiver Unit

This unit operates either in a direct (local) mode or in a remote (cascade) mode. In the former case, this unit receives the pneumatic output signal (20 to 100 kPa {0.2 to 1.0 kgf/cm²}) of the transmitter section and converts it into mechanical displacement which is fed via the overtravel link to the deviation generating mechanism in order to be magnified to drive the process variable (PV) pointer.

In the latter case, this unit receives an external pneumatic pressure setting signal (20 to 100 kPa {0.2 to 1.0 kgf/cm²}) and converts it into mechanical displacement which is fed via the overtravel link to the deviation generating mechanism in order to drive the setpoint (SP) pointer.

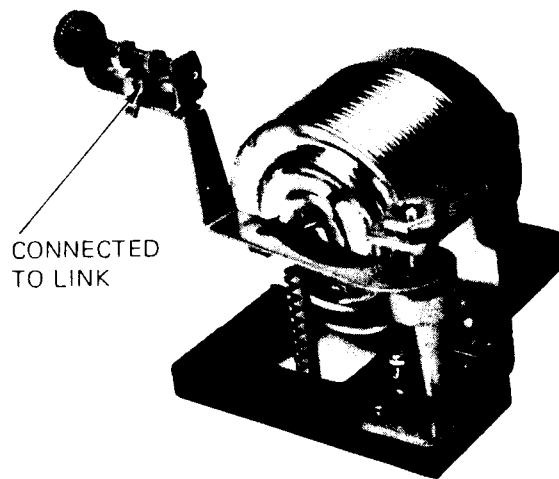

Figure 1-11 Receiver Unit

1.6.6 Batch Switch Unit

This unit is used to prevent overswing (in the positive direction only) of a batch process when it is initialized.

When the controller output pressure has exceeded a preset limit pressure (60 to 110 kPa {0.6 to 1.1 kgf/cm²}), the switch trips to suppress the output pressure to below the preset pressure.

preload pressure to the RES port of the controller.

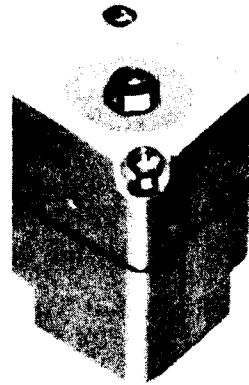
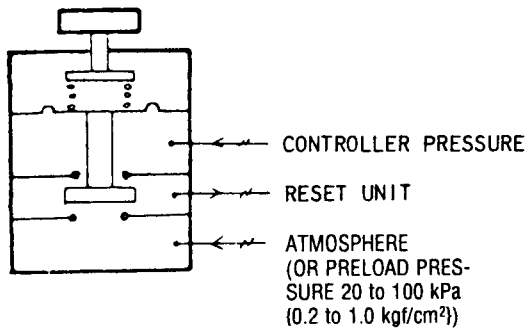

Figure 1-12 Batch Switch Unit

2. INSTALLATION

The installation method differs as the controllers are used in conjunction with the various types of detectors. For the installation and process connection methods, refer to the operator's manuals of respective detectors. This section describes primarily the pneumatic piping method for the controller.

2.1 Ambient Conditions

The place of instrument installation should be free from large or sharp temperature change and from mechanical vibration.

2.2 Air Supply

The air supply must be dry and clean.

2.3 Air Connection Ports

The air connection ports are provided at lower sections of the controller and are of a Rc, 1/4 (PT 1/4) internal thread type or 1/4 NPT internal thread type. Seal the unused ports with plugs.

When an Airset is provided, connect the air supply to the air inlet port (Rc, 1/4 or 1/4 NPT), which is marked "IN" of the Airset.

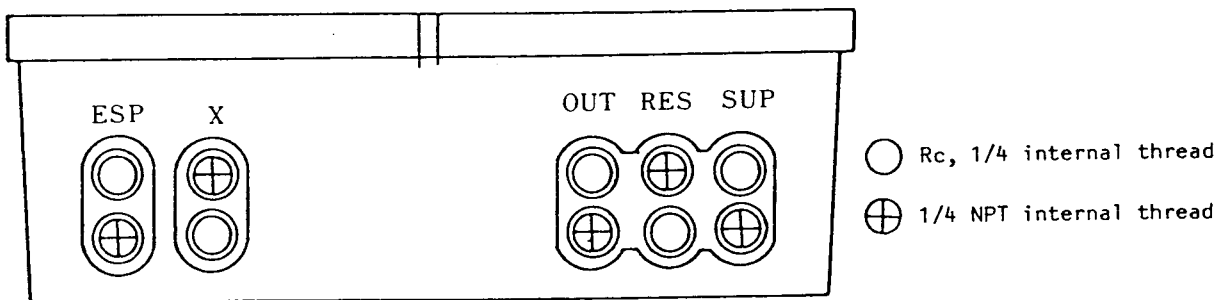

Legends

EXP: External setting pressure signal
X: Receiving or transmitting pressure signal
OUT: Pneumatic controller output signal
RES: External reset signal
SUP: Air supply

Figure 2-1 External Connection Ports (at case bottom)

3. OPERATION METHOD

This section covers the operation method of the controller. For the detector which is used in conjunction with the controller, refer to the operator's manual of the detector itself.

3.1 Preparation

Check the air piping for that they are correctly connected and there is no leak.

3.2 Instrument Without Manual Loader

3.2.1 Select a type (direct or reverse) of control action to suit the process and set the controller units as follows:

Proportional band (P): Maximum (PROP BAND dial at 500%)

Integral time (I): Maximum (RESET dial at 30 minutes)

Derivative time (D): Minimum (RATE dial at 0.05 minutes)

3.2.2 Set the SP pointer at the desired point by means of the SP (setpoint) knob. When the SP knob is provided on the door front, the setpoint can be varied by rotating the knob keeping it pressed against the door. When in the cascade (remote) mode, the setpoint can be varied by varying the external setpoint pressure signal.

3.2.3 Feed the air supply. Set the PID actions to suit the process to be controlled.

3.3 Instrument With Manual Loader

3.3.1 Manual Operation

First, stabilize the process by manual operation. Set the A-M Selector lever to the M position and adjust the pressure regulator so that the output pressure becomes the desired process value.

3.3.2 Automatic Operation

For automatic operation in general, proceed as follows:

(1) Select a type (direct or reverse) of control action to suit the process and set the controller units as follows:

Proportional band (P): Maximum (PROB BAND dial at 500%)

Integral time (I): Maximum (RESET dial at 30 minutes)

Derivative time (D): Minimum (RATE dial at 0.05 minutes)

(2) Feed the air supply.

- (3) Set the A-M transfer lever to the M position and adjust the pressure regulator so that the output pressure becomes the desired process value.
- (4) Set the SP pointer at the desired point by means of the SP (setpoint) knob. When the SP knob is provided on the door front, the setpoint can be varied by rotating the knob keeping it pressed against the door. When in the cascade (remote) mode, the setpoint can be varied by varying the external setpoint pressure signal.
- (5) Change the A-M transfer switch from the M position to the A position.
- (6) In the AUTO mode of operation, select appropriate PID values to suit the process.
- (7) To transfer from the AUTO mode to the MAN mode, press the check button with the switch set in the A position in order to read the manual output. Adjust the MAN output to the AUTO output by means of the pressure regulator and confirm that the output pressure gauge does not change even when the check button is pressed, and then change the lever from the A position to the M position. Refer to Item 4 of Section 1.5. (When changing the transfer lever, be sure to move it quickly and fully to the position where it stops.)

3.4 Setting of Batch Switch

- (1) Connect a precision pressure gauge to measure the pneumatic controller output signal.
- (2) Set the controller units as mentioned below. Apply a slight deviation input (in the direction that the output increases) so that the pneumatic controller output signal increases and saturates.

Proportional band (P): PROP BAND dial at 50%

Integral time (I): RESET dial at 0.05 minutes

- (3) Set the output pressure at the desired batch setpoint by turning the setting screw of the batch switch. The output decreases as you turn the setting screw clockwise.
- (4) When no batch control function is necessary, set the setting screw at the counterclockwise extreme position.

Note 1: When operating the batch switch, keep open the RES port at the bottom of the instrument. For preloading, apply a preload pressure to the RES port.

Note 2: Refer to Item (3) of Section 5.1.3.

3.5 To Make Derivative Action Ineffective

The derivative action can be made ineffective without removing the derivative unit. To accomplish this, turn the derivative action off switch (RATE OFF switch) to the counterclockwise extreme position. When the derivative action is needed to be brought into effect, turn the switch to the clockwise extreme position. This provision is convenient when adjusting the controller mechanism.

4. CALIBRATION AND ADJUSTMENT OF TRANSMITTER SECTION

4.1 General

The detector section (meter body section) generates with its torque tube a torque which is proportional to the measured process variable. The generated torque is conveyed to the transmitting mechanism of the transmitter. Therefore, regardless of the type of the detector used in conjunction, the transmitter section should be adjusted so that it transmits a linear output of 20 to 100 kPa {0.2 to 1.0 kgf/cm²} for 1 to 100% of the measuring range.

If the instrument is incorporated with the elevation/suppression provision, remove the spring assembly so that the instrument can be calibrated in the state that has no elevation or suppression and that its zero point is not shifted.

For instrument operation check or calibration or for instrument adjustment after replacing its detectors or ranges, connect a precision pressure meters of 0 to approximately 150 kPa {1.5 kgf/cm²} to the EXT SP connection port of the instrument.

4.2 Calibration of Differential Pressure Transmitter

- (1) Release the low pressure connection port (marked L) to atmosphere.
- (2) Connect to the high pressure connection port (marked H) a variable pressure source (such as the air supply via a regulator) corresponding to the measuring range and a precision pressure gauge covering the measuring range. (For a flange type meter body, prepare a piping adaptor.)
- (3) Apply to the high pressure connection port a pressure corresponding to 100% of the measuring range by adjusting the variable pressure source.
- (4) If the output pressure is largely shifted from 100% (100 kPa {1.0 kgf/cm²}), adjust the SPAN CHANGE boss using a plain screwdriver so that the output pressure becomes approximately 100%. As you turn the boss clockwise, the output pressure rises and the span becomes narrower. As you turn the boss counterclockwise, the output pressure falls and the span becomes wider.
- (5) Release the high pressure connection port to atmosphere.
- (6) If the output pressure is shifted from 0% (20 kPa {0.2 kgf/cm²}), adjust the ZERO ADJ screw so that the output pressure becomes 0%. As you turn the screw clockwise, the output pressure rises, and vice versa.

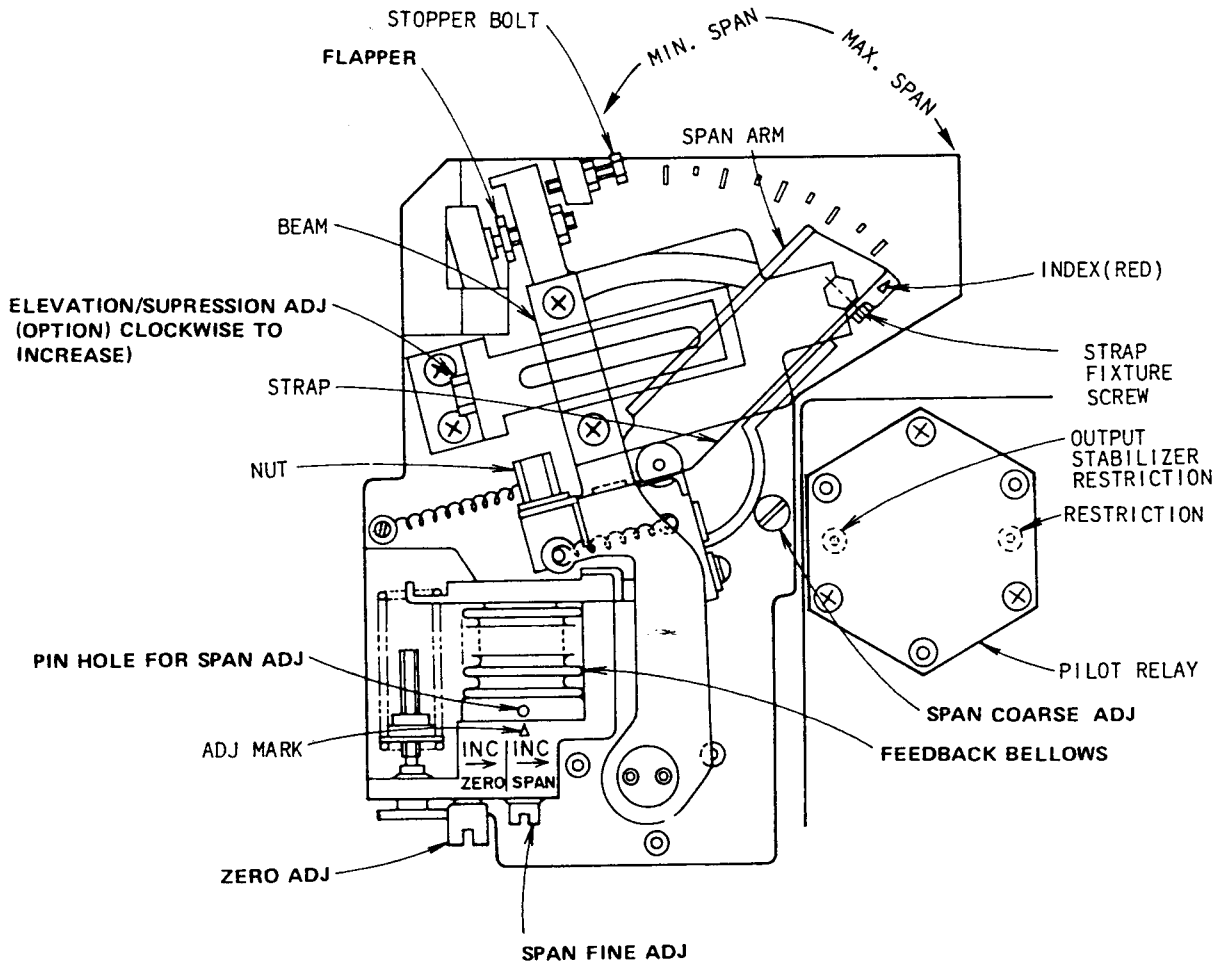

Figure 4-1 Transmitter Section

- (7) Apply to the high pressure connection port a pressure corresponding to 100% of the measuring range.
- (8) If the output pressure is shifted from 100%, adjust the SPAN ADJ boss at the bottom of the feedback bellows as follows:

If the output is higher than 100%, turn the boss so that the output becomes lower than 100% by an amount of 1/4 of the shift. (For example, if the output is 104%, turn the boss so that the output becomes $100 - 1/4 \times 4 = 99(\%)$).

If the output is lower than 100%, turn the boss so that the output becomes higher than 100% by an amount of 1/4 of the shift. For example, if the output is 98%, turn the boss so that the output becomes $100 + 1/4 \times 2 = 100.5(\%)$.

The span can be adjusted also by turning the feedback bellows by inserting a pin in the SPAN ADJ PIN HOLE instead of adjusting the SPAN ADJ boss. As you turn the feedback bellows, the span changes as follows:

Clockwise turn of bellows: Output increases. (Span becomes wider.)

Counterclockwise turn of bellows: Output decreases. (Span becomes narrower.)

- (9) Repeat the procedures of (5) - (8) until the required accuracy is attained.

4.3 Calibration of Gauge Pressure Transmitter

- (1) Connect to the process pressure connection port of the meter body a variable pressure source (such as the air supply via a regulator) corresponding to the measuring range and a precision pressure gauge covering the measuring range. (For a flange type meter body, prepare a piping adaptor.)
- (2) Apply to the process pressure connection port a pressure corresponding to 100% of the measuring range by adjusting the variable pressure source.
- (3) If the output pressure is largely shifted from 100% (100 kPa {1.0 kgf/cm²}), adjust the SPAN CHANGE boss so that the output pressure becomes approximately 100%. As you turn the boss clockwise, the output pressure rises and the span becomes narrower. As you turn the boss counterclockwise, the output pressure falls and the span becomes wider.
- (4) Release the process pressure connection port to atmosphere.
- (5) If the output pressure is shifted from 0% (20 kPa {0.2 kgf/cm²}), adjust the ZERO ADJ screw so that the output pressure becomes 0%. As you turn the screw clockwise, the output pressure rises, and vice versa.
- (7) If the output pressure is shifted from 100%, adjust the SPAN ADJ boss at the bottom of the feedback bellows as follows:

If the output is higher than 100%, turn the boss so that the output becomes lower than 100% by an amount of 1/4 of the shift. For example, if the output is 104%, turn the boss so that the output becomes $100 - 1/4 \times 4 = 99(\%)$.

If the output is lower than 100%, turn the boss so that the output becomes higher than 100% by an amount of 1/4 of the shift. For example, if the output is 98%, turn the boss so that the output becomes $100 + 1/4 \times 2 = 100.5(\%)$.

The span can be adjusted also by turning the feedback bellows by inserting a pin in the SPAN ADJ PIN HOLE instead of adjusting the SPAN ADJ boss. As you turn the feedback bellows, the span changes as follows:

Clockwise turn of bellows: Output increases. (Span becomes wider.)

Counterclockwise turn of bellows: Output decreases. (Span becomes narrower.)

- (8) Repeat the procedure of (4) - (7) until required accuracy is attained.

4.4 Calibration of Absolute Pressure Transmitter (Refer to Procedure of Section 4.3)

To calibrate a transmitter which has a vacuum measuring range alone or which has a compound measuring range including a vacuum range at a substantial rate, use such devices as vacuum pump and needle valve for the variable pressure source. For pressure measurement, use a digital vacuum manometer or a mercury column. A transmitter which has a compound measuring range of which major portion is a positive pressure range may be calibrated using an input pressure which is percent equivalent of the atmospheric pressure.

4.5 Calibration of Liquid Level Transmitter (KFLB □□-51/52)

- (1) Fix the torque tube assembly together with the transmitter to a bench by using, for example, a vice as shown in Figure 4-2.

Note: Exercise care so that no unreasonably large torque is applied to the torque tube.

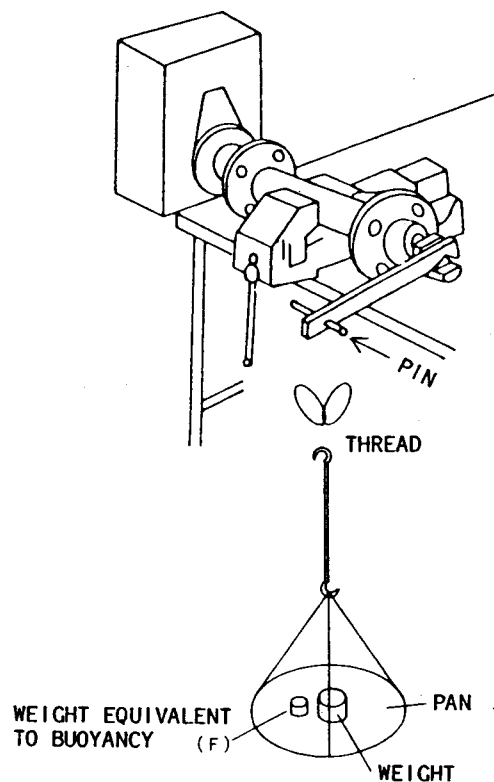

Figure 4-2

- (2) Prepare a weighing pan as shown in Figure 4-2 and hang it on the pin at the end of the torque tube using a thread or fine wire looped into two circlets.

- (8) If the output pressure is shifted from 100%, adjust the SPAN ADJ boss at the bottom of the feedback bellows as follows:

If the output is higher than 100%, turn the boss so that the output becomes lower than 100% by an amount of 1/4 of the shift. (For example, if the output is 104%, turn the boss so that the output becomes $100 - 1/4 \times 4 = 99(\%)$).

If the output is lower than 100%, turn the boss so that the output becomes higher than 100% by an amount of 1/4 of the shift. For example, if the output is 98%, turn the boss so that the output becomes $100 + 1/4 \times 2 = 100.5(\%)$.

The span can be adjusted also by turning the feedback bellows by inserting a pin in the SPAN ADJ PIN HOLE instead of adjusting the SPAN ADJ boss. As you turn the feedback bellows, the span changes as follows:

Clockwise turn of bellows: Output increases. (Span becomes wider.)

Counterclockwise turn of bellows: Output decreases. (Span becomes narrower.)

- (9) Repeat the procedures of (6) - (8) until the required accuracy is attained.

Note: For specific-gravity change, ZERO and SPAN adjustment, refer to Sections 2 and 3. Specific-gravity change is corresponding to SPAN change in such sections.

4.5.2 Calibration Procedure for Boundary Liquid Level Transmission

- (1) This procedure is identical with that for liquid level transmission, except that the following formulas should be used:

- (a) Total weight W including the two weights, pan and others:

$$W = (\text{Weight of float}) - \frac{\pi}{4} D^2 \cdot L \cdot \rho_1$$

where, ρ_1 : Density of upper liquid

- (b) Calibration weight (F) corresponding to buoyancy:

$$F = \frac{\frac{\pi}{4} \cdot D^2 \cdot H (\rho_2 - \rho_1)}{1 + a \cdot \pi \cdot D^2 (\rho_2 - \rho_1)}$$

where, ρ_2 : Density of lower liquid

4.5.3 Calibration procedure for Specific-gravity Transmission

(1) This procedure is identical with that for liquid level transmission, except that the following formulas should be used.

(a) Total weight W including the two weights, pan and others:

$$W = (\text{Weight of float}) - \frac{\pi}{4}D^2 \cdot L \cdot \rho_l$$

where, ρ_l : Low limit of specific-gravity range

(b) Calibration weight (F) corresponding to buoyancy:

$$F = \frac{\frac{\pi}{4}D^2 \cdot H(\rho_H - \rho_l)}{1 + \alpha \cdot \pi \cdot D^2 \cdot H(\rho_H - \rho_l)}$$

where, ρ_H : High limit of specific-gravity range
range

4.5.4 Adjustment of Stopper

(1) When the instrument is shipped from the factory, the torque tube is installed in the correct angle. When the torque tube housing, bonnet and side flange are detached in the field and assembling them, pay attention to the following:

Adjust the gap at 2.5 mm from the low limit stopper by means of plays of the bolt holes when the float is hung as shown in Figure 4-3.

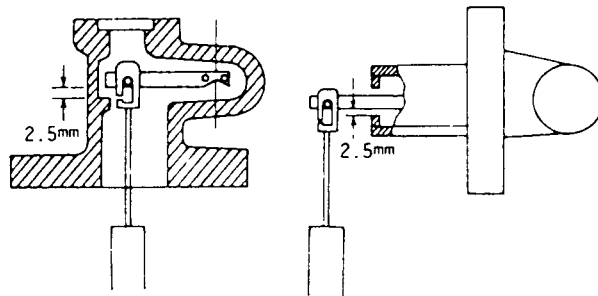

Figure 4-3

4.6 Calibration of Liquid Level Transmitter (KFLB □□-31/32)

Fix the meter body together with the transmitter to a bench by using, for example, a vice as shown in Figure 4-4.

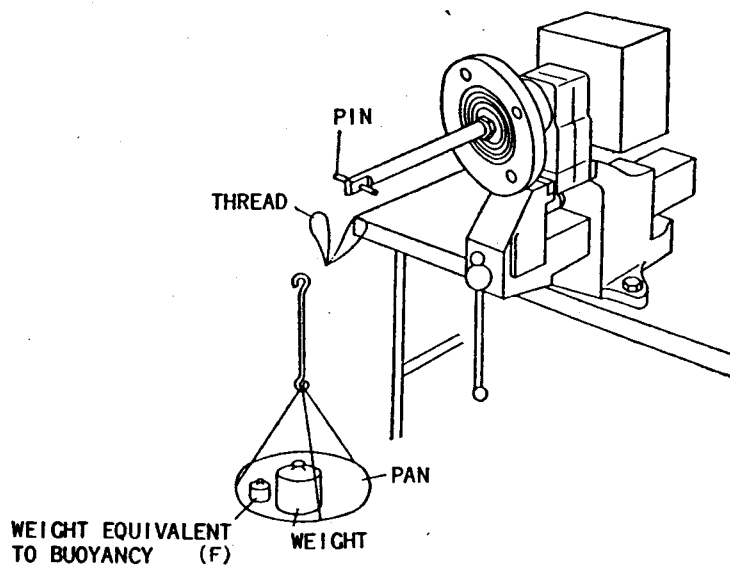

Figure 4-4

Under the above state, perform a procedure identical with that of Sections 4.5.1 through 4.5.3 with the only difference being that the following formula is used for calculation of buoyancy:

$$F = \frac{\pi}{4} \cdot D^2 \cdot H \cdot \rho$$

For adjustment (calibration) keep the damping control fully open.

No stopper adjustment is needed for Model KFLB □□-31/32. When using the KFLB □□-31/32 for boundary liquid level or specific-gravity transmission, use the following formulas for calculation of weight (F) corresponding to buoyancy:

Boundary liquid level: $F = \frac{\pi}{4} D^2 L (\rho_2 - \rho_1)$

Specific-gravity: $F = \frac{\pi}{4} D^2 L (\rho_H - \rho_L)$

5. CALIBRATION AND ADJUSTMENT OF DEVIATION GENERATING MECHANISM

Align together the PV pointer and SP pointer as described in the following:

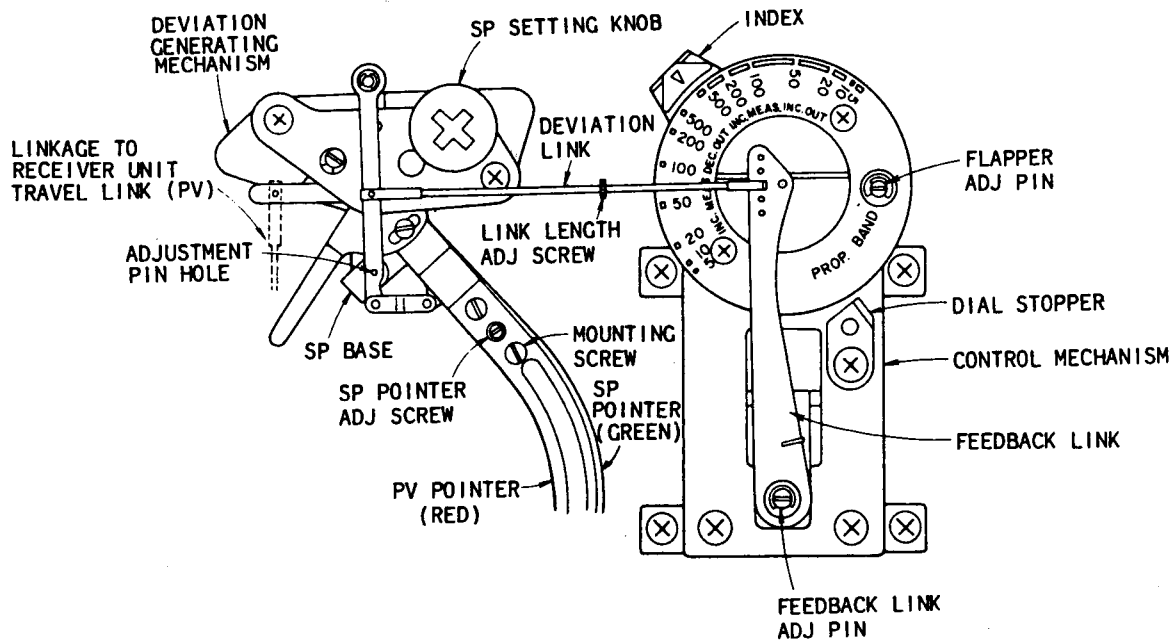

Figure 5-1 Deviation Generating Mechanism

- (1) Set the PV pointer of approximately 50% on the scale either by removing the link which runs from the receiver unit or by making the PV input approximately 50%.
- (2) Align the SP pointer with the PV pointer by adjusting the setpoint knob for a local type of instrument or by applying a corresponding external setpoint pressure for a case type of instrument.
- (3) Inset the adjustment pin (1.2 mm dia.) through the adjustment pin hole.
- (4) If the SP pointer has not been accurately aligned with the PV pointer, align it accurately by means of the SP pointer adjustment screw. If the screw does not rotate smoothly, loosen the mounting screw. After the adjustment is over, tighten the screw securely. Connect a pressure gauge of Class 0.5 to the OUT port and an air supply of 140 kPa (1.4 kgf/cm²) to the SUP port.

5.1 Calibration and Adjustment of Controller Mechanism

5.1.1 Balance Adjustment of Proportional Band of Controller

Remove the dial stopper by loosening its screw and then proceed as follows:

- (a) Set the proportional band at 500%.

- (b) Set the SP and PV pointers at 50%.
- (c) Set the integral mechanism to the full open state (the minimum integral time). Move the SP pointer so that the output air pressure becomes 50% FS (59.1 kPa {443 mmHg}).
- (d) After the output air pressure is stabilized, set the reset mechanism to the fully closed state (the maximum integral time) and align the two pointers together at 50% FS.
- (e) Adjust the length of the deviation link so that change in output pressure when the proportional band is set to 20% (INC. MEAS. INC. OUT and DEC. OUT) is not greater than 0.8 kPa {6 mmHg}.
- (f) Adjust the flapper adjustment pin so that change in output pressure when the proportional band is changed from 20% to 500% is not greater than 0.8 kPa {6 mmHg}. (If the output pressure is larger when the proportional band is 500% than that when 20%, turn the pin clockwise.)
- (g) With the proportional band set at 500%, adjust the feedback adjustment pin so that the output pressure becomes 59.1 ± 0.3 kPa { 443 ± 2 mmHg}. (The output pressure increases as you turn the pin clockwise.)
- (h) Repeat the procedure of (e), (f) and (g) so that the output pressure becomes 59.1 ± 1.2 kPa { 443 ± 9 mmHg} when the proportional band is within a range of white figures 50 to 500 to yellow figure 6.7 kPa or 59.1 ± 2.4 kPa { 50 or 443 ± 18 mmHg} at other ranges.

Notes 1. By the procedure of (d), a pressure of approximately 59.1 kPa {443 mmHg} is sealed in the integral chamber of the controller. Since this pressure may vary if the controller is left in this state for a prolonged period of time, perform the above procedures as rapidly as possible.

- 2. To switchover between the INC. MEAS. INC. OUT action (direct action) and INC. MEAS. DEC. OUT action (reverse action), hang down once the stopper by loosening its screw, turn the proportional dial passing through the pin, move the stopper to the other side, and then fix the stopper in the original state.

5.1.2 Calibration of Integral (Derivative) Unit

Exercise care when handling the restriction mechanism for the integral (derivative) action. Even a slight scrape on the needle or seat may greatly affect the performance. In view of this, the integral (derivative) restriction mechanism and the dial base are securely fixed. To calibrate the instrument, proceed as follows:

(1) Integral Unit

- (a) Set the setpoint (SP) at 50% FS.

- (b) Set the proportional band dial at 100 (%PV) in the direct action mode. When doing this, make the integral restriction mechanism full open (less than 0.05 minutes). If the derivative mechanism also is incorporated, make it also is incorporated, make it also full open (less than 0.05 minutes).
- (c) Balance the pneumatic controller output pressure at 46.7 kPa {350 mmHg} by adjusting the PV input.
- (d) Fully close the derivative restriction mechanism (30 minutes or more).
- (e) Balance the pneumatic controller output pressure at 53.3 kPa {400 mmHg} by adjust the PV input.
- (f) Set the integral dial (reset dial) scale at 2 minutes.
- (g) Count the time the controller output takes to change from 53.3 kPa {400 mmHg} to 60 kPa {450 mmHg}.
- (h) Check that the counted time is within 120 ± 60 seconds.
- (i) As required, shift the position of the dial of the integral unit and fix it in the new position.

(2) Derivative Unit

- (a) Set the setpoint (SP) at 50% FS
- (b) Set the proportional band dial at 100 (%PB) in the direct action mode. Make the derivative restriction mechanism full open (less than 0.05 minutes). If the integral mechanism also is incorporated, make it also full open (less than 0.05 minutes).
- (c) Balance the controller output pressure at 40 kPa {300 mmHg} by adjusting the PV input.
- (d) Change the integral (reset) and derivative (rate) dials to the fully closed state (30 minutes or more).
- (e) Balance the controller output pressure at 80 kPa {600 mmHg} by adjusting the PV input. (Denote this value by n_1 .)
- (f) Make the integral dial full open (less than 0.05 minutes) and measure the residual pressure. Denote this value by n_2 .) Calculate the derivative amplitude as follows:
- (g) Repeat the procedure of (b) through (e) and set the controller output pressure at 80 kPa {600 mmHg}.

- (h) Rapidly change the derivative dial to the point of 2 minutes and count the time the output pressure takes to change to 63.2% of the value of $(n_1 - n_2)$.
- (i) Check that $t \times W$ is within 120 ± 60 seconds.
- (j) As required, shift the position of the index of the derivative unit and fix it in the new position.

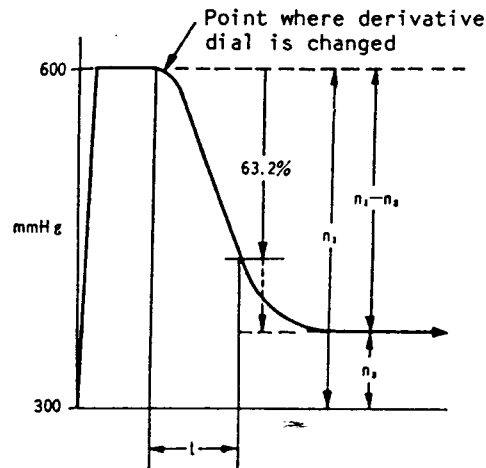

Figure 5-2 Calibration of Derivative Action

5.1.3 Other Calibration and Adjustment

(A) ON/OFF Controller

Before starting adjustment, check zero deviation as follows:

- (a) Set the setpoint at 50%.
- (b) Remove the travel link (PV) of the indicating mechanism side and insert the adjustment pin.
- (c) Check that the PV pointer and the SP pointer are accurately aligned together. If there is any shift, correct is by means of the SP pointer adjustment pin.
- (d) Remove the adjustment pin and connect the travel link (PV).

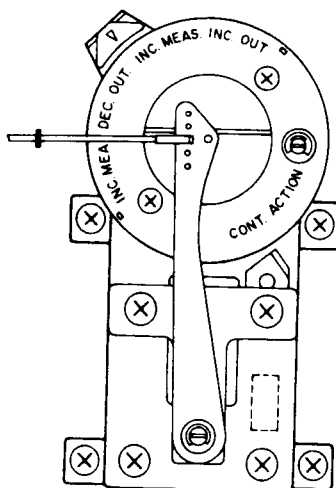

Figure 5-3 ON/OFF Controller Unit

Adjustment

- (1) Turn the setting dial full counterclockwise and align it with the white line at the end of the INC. MEAS. INC. OUT side. Adjust the deviation so that the output becomes 59.1 ± 0.8 kPa { 443 ± 6 mmHg} and read the deviation with the pointers on the scale.
- (2) Turn the setting dial full counterclockwise and align it with the yellow line at the end of the INC. MEAS. DEC. OUT side. Make adjustment in a similar manner as in the case of (1).
- (3) Adjust the length of the deviation link so that the deviations read in (1) and (2) become identical values but in reverse directions. The length becomes shorter as you turn upward the deviation link adjustment screw. If the deviations are in the same direction and the reading of the red pointer is higher than that of the green pointer, lengthen the link; if the reading of the green pointer is higher, shorten the link.
- (4) Set the deviation at 0 (zero) and align the setting dial with the white line. Adjust the flapper adjustment screw so that the output is stabilized at a point within a range of 10 to 130 kPa {0.1 to 1.3 kgf/cm²}.
- (5) Align the setting dial with the yellow line. Adjust the length of the deviation link so that the output is stabilized at a point within a range of 10 to 130 kPa {0.1 to 1.3 kgf/cm²}.
- (6) Repeat the procedure of (4) and (5) so that the output is stabilized at a point within a range of 10 to 130 kPa {0.1 to 1.3 kgf/cm²} regardless of whether the dial is aligned with the white line or with the yellow line.

3) Differential Gap Controller

Before starting adjustment, check zero deviation as follows:

- (a) Set the setpoint at 50%.
- (b) Remove the travel link (PV) on the indicating mechanism side and insert the adjustment pin.
- (c) Check that the PV pointer and the SP pointer are accurately aligned together without any shift. If there is any shift, align them accurately by means of the SP pointer adjustment pin.
- (d) Remove the adjustment pin and connect the travel link (PV).

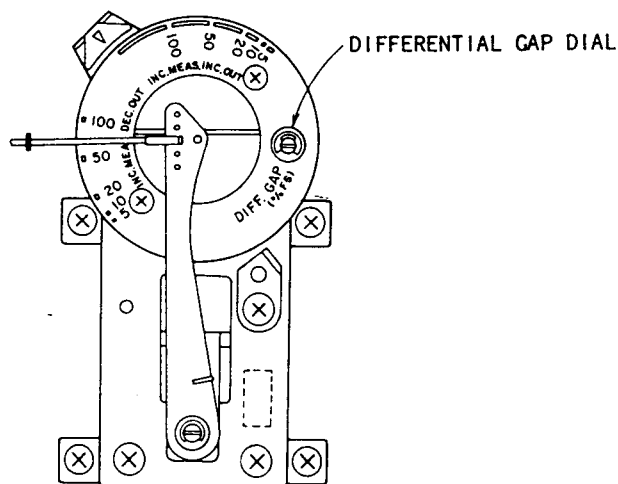

Figure 5-4 Differential Gap Controller Unit

Adjustment

- (1) Make initial setting of the flapper adjustment pin and the feedback link adjustment pin as follows:
 - (a) The flapper pin can be rotate 360 degrees of angle. Turning the pin clockwise, set the pin groove horizontally at the side that the flapper rises.
 - (b) The feedback pin also can be rotated 360 degrees of angle. Turning the pin clockwise, set the pin groove horizontally at the side that the link falls.
- (2) Set the setpoint at 50%. Set the differential gap setting dial at the minimum (0%) position of the INC. MEAS. INC. OUT side. Check the output pressure rise and fall points by moving the PV pointer, and determine the difference between the two points.
- (3) Set the dial at the minimum position of the INC. INC. MEAS. DEC. OUT side. Check the output pressure rise and fall points by moving the PV pointer.

- (4) Adjust the deviation link so that the output rise points of (2) and (3) are distributed with the setpoint as the center of distribution. If the distribution point is shifted in the positive direction, lengthen the link (turn the screw downward). If it is shifted in the negative direction, shorten the link (turn the screw upward).
- (5) Adjust the flapper adjustment pin so that the output rise points of (2) and (3) conform with the setpoint. Repeat the procedure of (4) and (5) until the operation points conform with the setpoint.
- (6) Set the differential gap (DIFF GAP) dial to the clockwise or counterclockwise 100% position. Adjust the feedback link adjustment pin so that the output increases at the setpoint position. (To lower the output once, open slightly the flapper with the tip of a screwdriver.)
- (7) Repeat the procedure of (4), (5) and (6) so that the output rise position is within setpoint (SP) $\pm 1.5\%$ FS at any point within the total range of the differential gap (DIFF GAP) dial.

(C) Setting of Batch Switch (See the Notes of Section 3.4.)

When the batch switch is incorporated, set the batch operation point as follows:

- (1) Connect the instrument output (OUT) connection port a pressure gauge of Class 0.5 better.
- (2) Set the proportional band setting dial of the controller mechanism to the INC. MEAS. DEC. OUT state and at 50%.
- (3) Set the dial of the integral unit at 0.02 minutes (at the minimum position).
- (4) Apply a deviation of 10 to 15% FS to the controller mechanism to increase the controller output until it saturates.
- (5) Turn the batch switch setting screw until the desired batch setting output is obtained. For this setting, loosen the lock nut once and turn the setting screw with a screwdriver. After the setting is over, tighten the lock nut.
- (6) When no batch control function is needed, turn the setting screw to the full counterclockwise position.

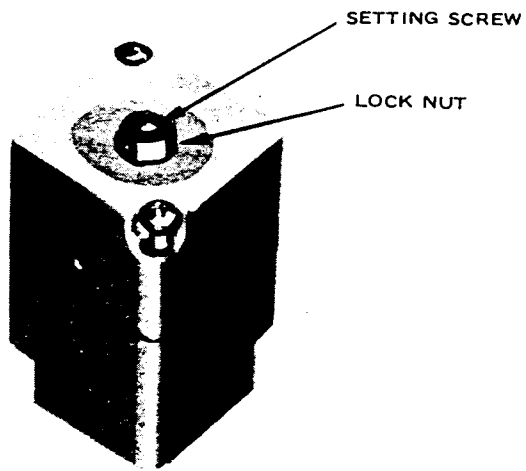

Figure 5-5 Batch Switch Unit

6. ADJUSTMENT OF INDICATING SECTION

Adjustment of the indicating section should be made after that for the deviation generating mechanism and controller mechanism is complete. The structure of the PV indicating mechanism and that of the SP indicating mechanism for the cascade mode of operation are identical. To adjust the PV indicator section, apply an input signal to the detector section (see Section 4). To adjust the SP indicator section, apply a pneumatic pressure (20 to 100 kPa {0.2 to 1.0 kgf/cm²}) to the ESP connection port of the instrument.

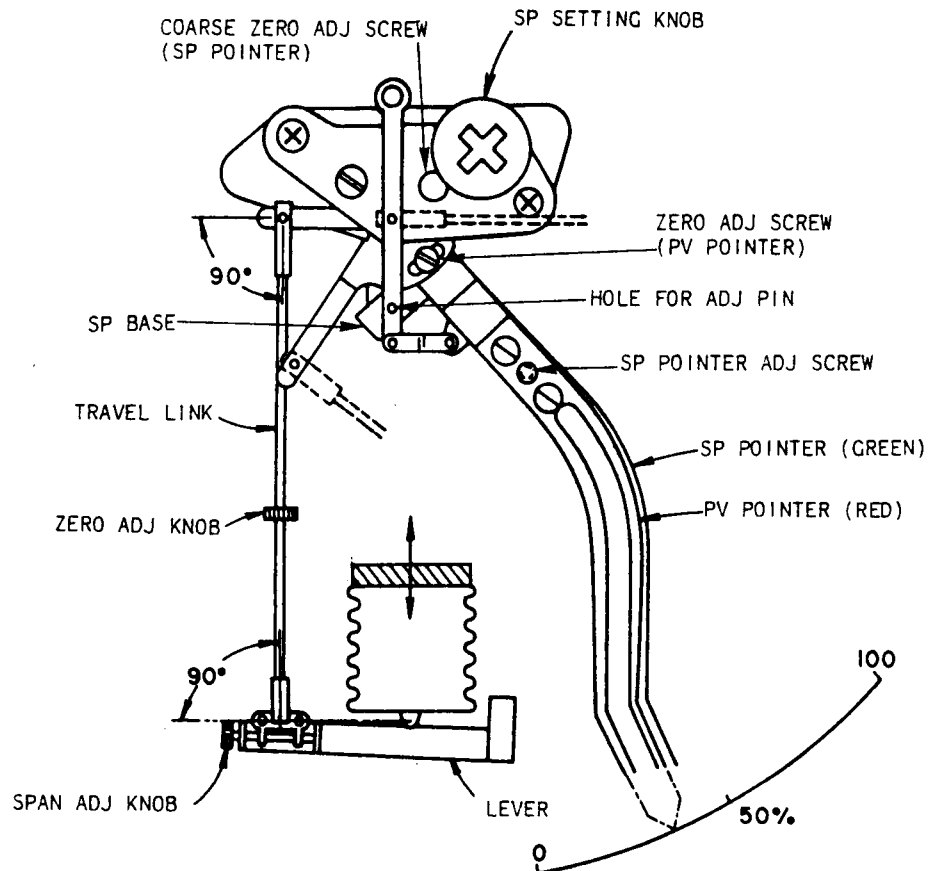

Figure 6-1

(1) Zero Adjustment

Apply 0% input and adjust the ZERO ADJ knob of the travel link so that the PV pointer indicates 0.

Indication is reduced as you turn knob clockwise as viewed from the instrument bottom.

(2) Span Adjustment

Apply 80% input and adjust the SPAN ADJ screw so that the PV pointer indicates 80%. The span increases as you turn the screw clockwise. When a large span change is necessary, change the connection point between the travel link and the hole of the span adjustment screw section. The span increases as the distance from the center of the mechanism increases.

(3) Linearity Adjustment

- (a) For linearity adjustment, use the 50% point of the scale.
- (b) If an error greater than 1% FS is found, vary the travel link length by turning the adjustment knob. If the error is in the positive side of the scale, shorten the travel link (turn the knob counterclockwise as viewed from the instrument bottom).
- (c) The zero point also will vary as the travel link length is varied. Loosen the ZERO ADJ screw, set the pointer to the zero point on the scale, and tighten the screw.
- (d) Check again the zero and span by repeating the above procedure.

7. MAINTENANCE

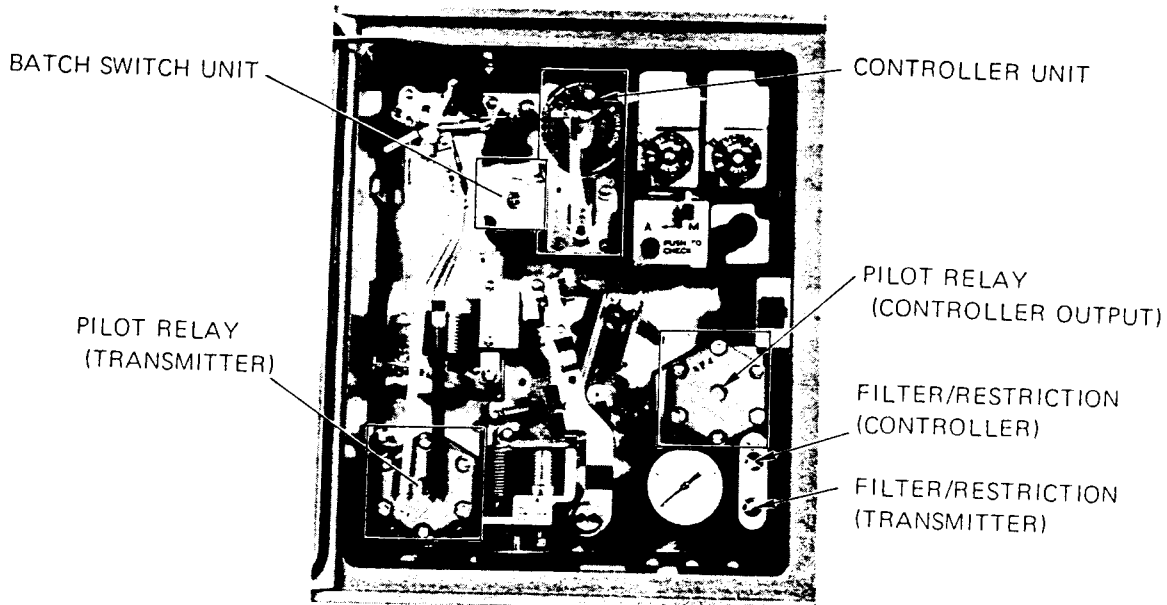

Figure 7-1 Points To Be Serviced For Maintenance

7.1 Periodical Inspection

- (1) Check the air pipes and joints for leak.
- (2) Check the air supply line drain, filter, compressor, air cleaner/drier, and tanks.
- (3) Check the instrument filters and restrictions for stains. Replace the stained filters. Clean the dirty restrictions using a needle wire of 0.12 mm diameter.

7.2 Controller Unit

- (1) Turn off the air supply and remove the deviation link.
- (2) Remove the four screws of the base, take out the controller unit, and clean the nozzle.
- (3) Install the controller unit following the removing procedure in the reverse order. Adjust the controller. Make sure that the O-rings are installed. Fix the controller securely with the four screws and confirm that there is no air leak.

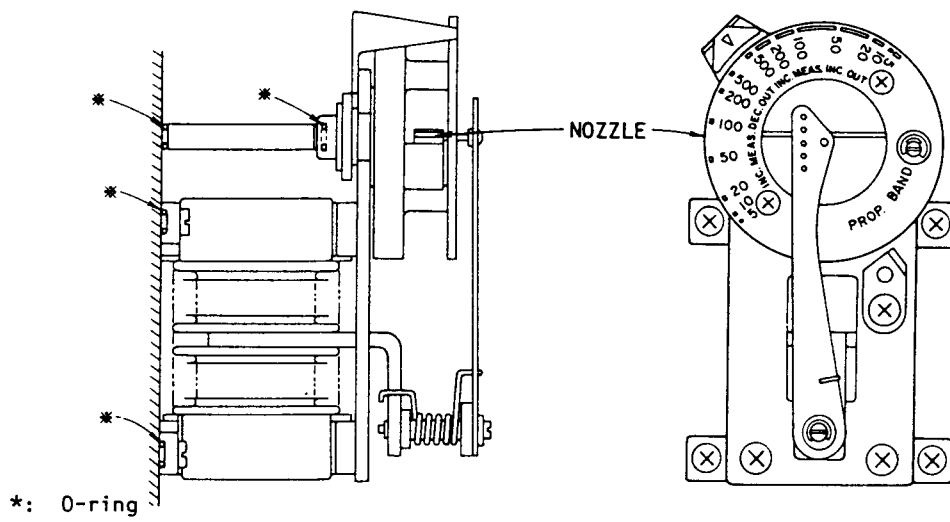
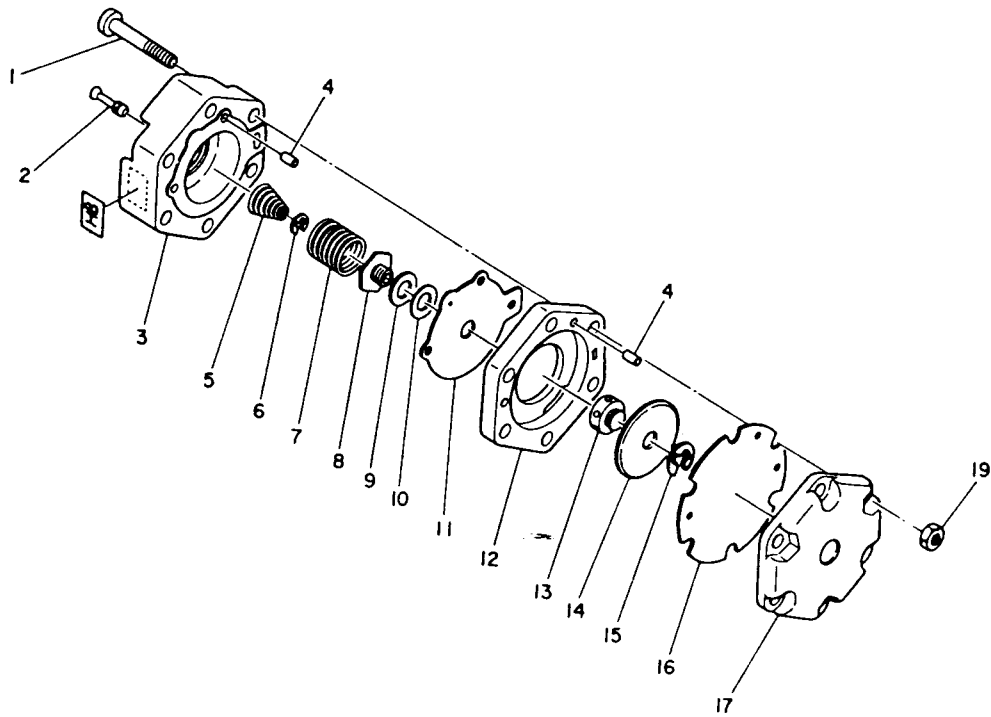

Figure 7-2 Maintenance of Controller Unit

7.3 Pilot Relay



No.	Name	Quantity
1.	SCREW	3
2.	VALVE STEM	1
3.	HOUSING	1
4.	GUIDE PIN	6
5.	CONICAL SPRING	1
6.	WASHER	1
7.	SPRING	1
8.	NOZZLE	1
9.	WASHER	1
10.	SEAL	1
11.	DIAPHRAGM (LOWER)	1
12.	EXHAUST RING (OUTER)	1
13.	EXHAUST RING (INNER)	1
14.	AREA PLATE	1
15.	WASHER	1
16.	DIAPHRAGM (UPPER)	1
17.	COVER	1
19.	NUT	3

Figure 7-3 Pilot Relay Assembly

Remove the pilot relay as described in 1 above, service it as described below, and then install it in the original position.

- (a) Remove the three assembly screws (1) and nuts (19). (See Figure 5.)
- (b) Parts (3) to (17) will separate in order. It is not necessary to separate parts (2) to (6) unless they are to be replaced.
- (c) Clean metal parts with approved solvent such as petroleum naphtha or Chlorothene. Depress the valve stem (2) against the conical spring (5) to allow the solvent to penetrate through the seat which is hit by the port section of the valve stem.
- (d) Examine the inner exhaust ring (3) and valve stem (2). If dirty, clean them with a cloth. Do not use any solvent to clean them.
- (e) Dry all parts thoroughly with clean compressed air.
- (f) Replace diaphragms (16) and (11) if worn or damaged.
- (g) Reassemble the pilot relay by rejoining all parts in order with assembly screws (1), and nuts (19). Tighten the screws evenly.

7.4 Removal of AUTO Unit When in MAN Mode

- (1) Balance the instrument and then transfer it to the MAN mode. (See Section 3-3.)
- (2) Apply a deviation in the direction that the AUTO output is decreased. (Turn the SP knob so that SP is smaller than PV when in the reverse action or SP is greater than PV when in the direct action.)
- (3) Set the proportional band of the controller to the minimum (PV not greater than 5%).
- (4) Press the CHECK button of the manual loader and check that the AUTO output is zero.
- (5) Remove the automatic controller units (controller unit, integral unit, and derivative unit). When this is done, the manual loading pressure will be decreased slightly (within 3% FS). Re-adjust the manual loading pressure as required.
- (6) When the SP is of a remote setting type (cascade type) and cannot be varied, proceed as follows instead of the procedure of (2) and (3).
 - (a) Remove the element of the link. Make the AUTO output zero by moving the PV pointer.
 - (b) Make the nozzle back pressure zero by moving the flapper away from the nozzle of the controller.

7.5 Maintenance of Batch Switch

Periodically clean the exhaust port with a needle wire of 0.8 mm diameter. The circuit board of the batch unit can be removed by removing its two clamping-screws. The exhaust port is located in the groove in the center on the back side of the batch switch unit.

7.6 Troubleshooting

Symptoms of troubles, probable causes, and remedies are shown in the following table. For adjustments, refer to the preceding section.

Symptom	Probable cause	Remedy
Pilot relay whines.	Stained valve stem (section hitting the port)	Take out pilot relay and clean the valve stem (section hitting the port)
No or only very low controller output pressure is delivered.	No air supply is provided or air supply pressure is lower than 140 kPa (1.4 kgf/cm ²).	Provide an air supply of correct pressure.
	Restriction is clogged.	Take out and clean the restriction.
	Restriction is not correctly installed.	Parts (restriction, blind plug, etc.) differ by whether instrument is incorporated with transmitter or not. Install correct parts at correct positions.
	Filter is stained.	Replace filter.
	Air leak in nozzle circuit of controller unit.	Check that O-rings are properly installed. Securely tighten the controller unit.
	Leak or clogging of A/M transfer circuit (for instrument with A/M transfer provision)	Take out manual loader unit, inspect its circuit, check that O-rings are properly installed, and securely install the unit.
	Leak in pilot relay diaphragm section	Take out pilot relay and inspect diaphragm. If leak is found, replace diaphragm.
Controller output pressure is too high.	Nozzle of controller unit is clogged.	Clean the nozzle.
	Stained valve seat of pilot relay	Take out pilot relay and clean the valve seat.

(to be cont'd)

Symptom	Probable cause	Remedy
Indication is with large input offset.	SP or PV pointer is shifted.	Re-adjust deviation generating mechanism and indicating mechanism.
	Controller mechanism is not properly adjusted. (Balancing of proportional band is improper.)	Adjust balancing of controller mechanism.
Integral rate is shifted, or integral action is ineffective.	Damaged needle or seat	Replace needle assembly with new one.
	Clamping screw of dial is loose.	Set the dial in the correct position and fix it securely with screw.
	Air leak of gasket	Securely fix to base.
Manual loading pressure is low.	No air supply is provided or air supply pressure is lower than 140 kPa (1.4 kgf/cm ²).	Provide proper air supply.
Manual loading pressure is high.	Valve stem of pressure regulator valve is stained or dusty.	Overhaul the pressure regulator.
Zero point shifts largely when ranges are changed.	Transmitter section is not properly adjusted.	Adjust and calibrate transmitter section.
Output is unstable or pulsates.	Air leak	Check and correct air connections and gaskets.
	Stained nozzle/flapper	Clean the nozzle/flapper.
	Stained pilot relay	Take out and clean the pilot relay. Replace it as required.

Pneumatic Circuit Diagram

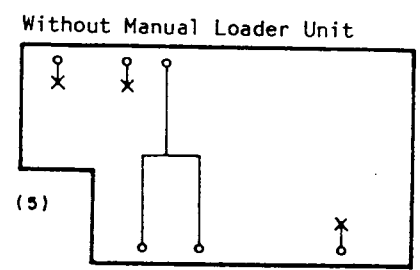
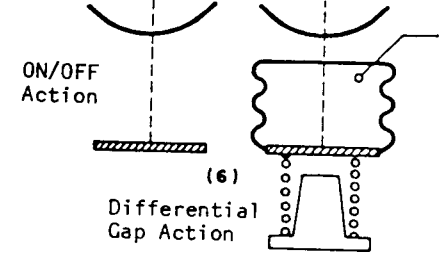
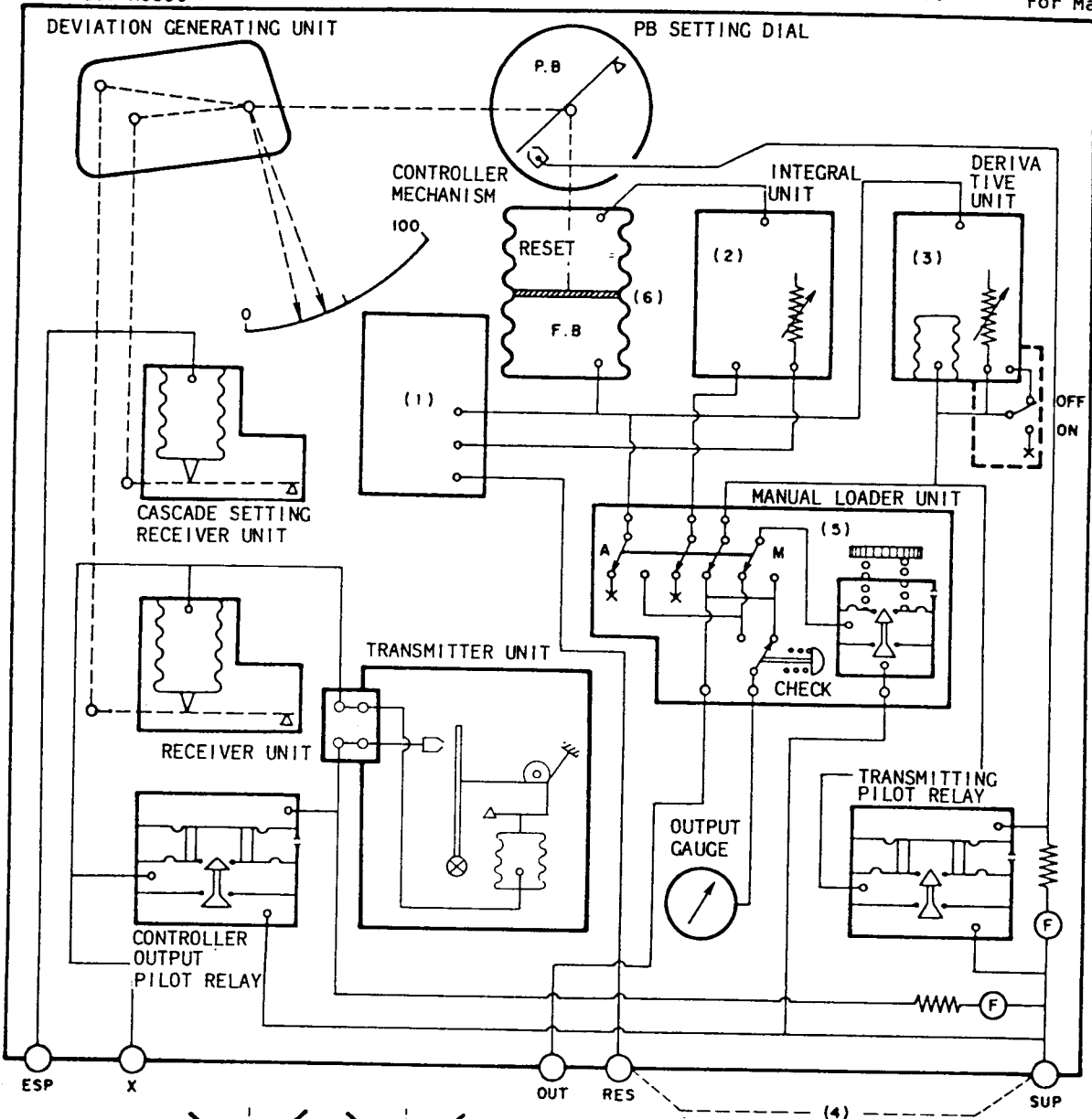
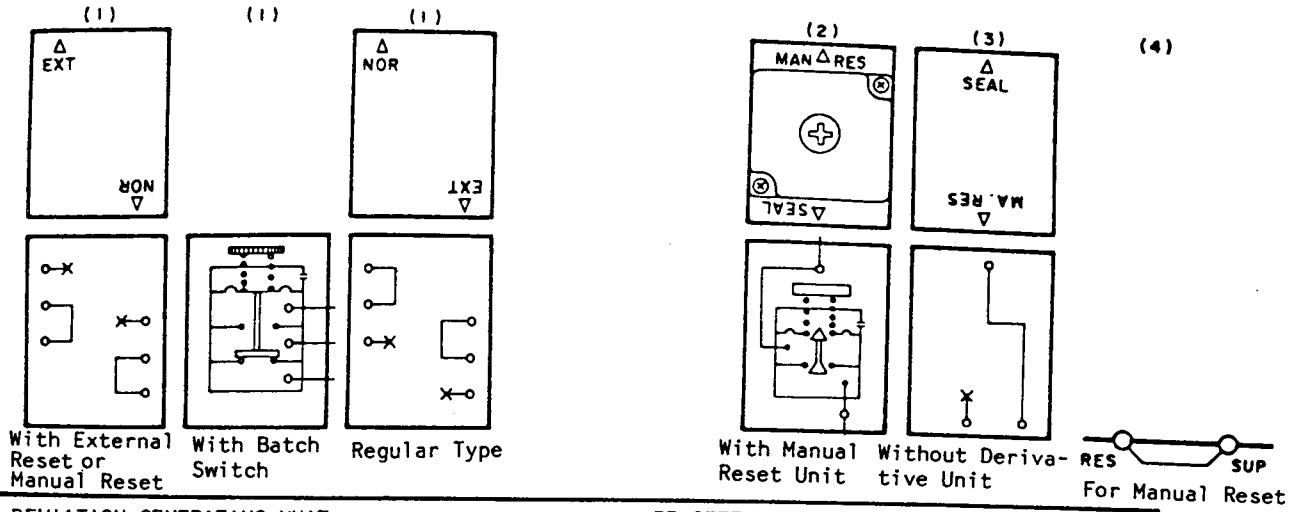

Document Number : OM2-6220-0000

Document Name : KF-B Series Field Mounted Indicating
Controller

Date : Feb., 2000 Rev.5(H)

Issued / Edited by : Yamatake Corporation
